

INTRODUCTION (1)

GI-1

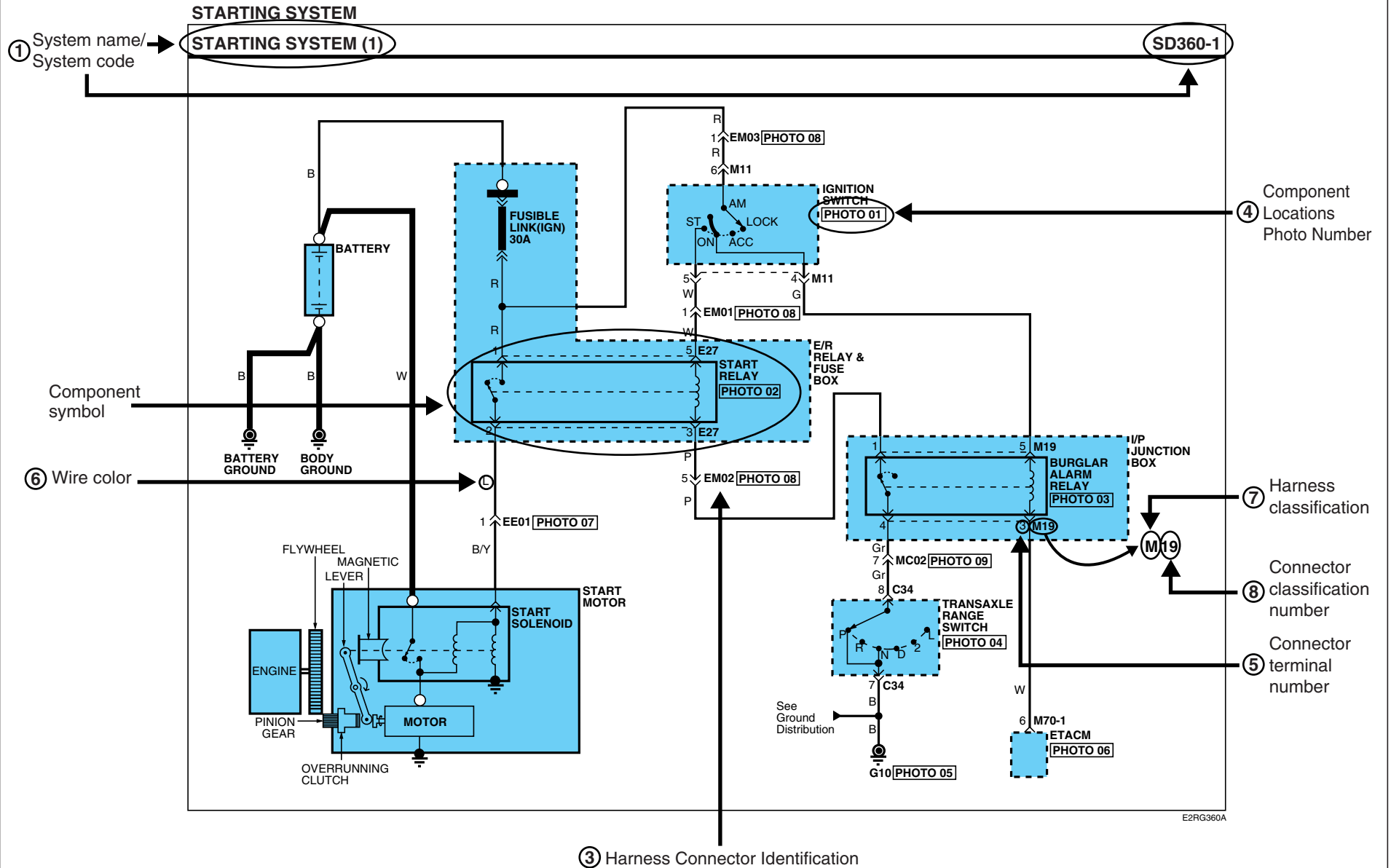

INTRODUCTION

INTRODUCTION (2)

GI-2

STARTING SYSTEM

STARTING SYSTEM (2)

SD360-2

② Connector configurations (components)

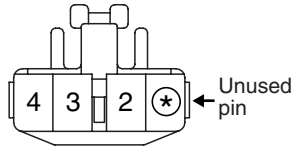
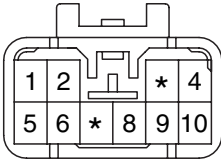
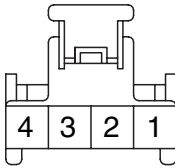
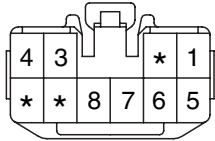
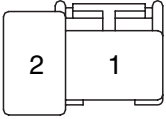
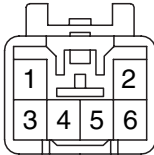
<p>M05</p>  <p>Unused pin</p> <p>KET_090II_04F_W</p>	<p>M06</p>  <p>KET_090II_10M_W</p>	<p>M11</p>  <p>KUM_AR_04F_W</p>	<p>M13</p>  <p>KET_090II_10F_W</p>
<p>M67</p>  <p>AMP_PLM2_02F_B</p>	<p>M81</p>  <p>KET_090II_06M_W</p>	<p>BLANK</p>	<p>BLANK</p>

E2RG360B

Connector Code Definition

M05

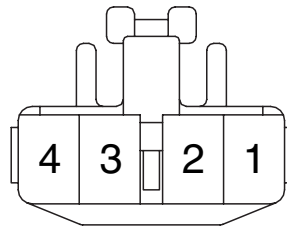

KET_090II_04F_W

a b c d e

a : Connector manufacturer

b : Terminal series number

c : The number of connector terminals

d : Connector pin configuration

Female Pin : F

Male Pin : M

e : Connector color abbreviations

- B (Black)
- Br (Brown)
- G (Green)
- Gr (Gray)
- L (Blue)
- R (Red)
- W (White)
- Y (Yellow)

① Pages by system/ Name of schematic diagram

- Each schematic diagram provides data related to current flow, switch functionality (where applicable), and related circuit information.
- Understanding circuit operation is a critical component of effective diagnosis.
- The schematic diagram index provides a guide to locating the correct circuit.

② Connector configuration (components)

- The pages following the schematic diagrams contain data related to component connector configuration. Each page shows a terminal side view of the connector. Refer to the "Connector View and Numbering Order" section in this document for information related to terminal numbering.
NOTE : a "*" symbol in place of a terminal number indicates an unused terminal (connector cavity will be empty).

③ Connector configurations (connection between harnesses)

- The "Connector Configurations" section identifies connectors that are used to join harnesses together; junction connectors for common power and ground wires are also identified in this section. Male and female connector views are shown where applicable.

EM02

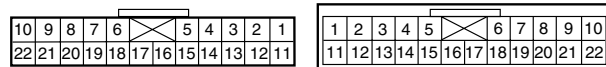

④ Component locations

- Schematic diagrams include references to images found in the "Component Locations" section of this document. These images show components and connectors in their installed location on the vehicle.

PHOTO 03

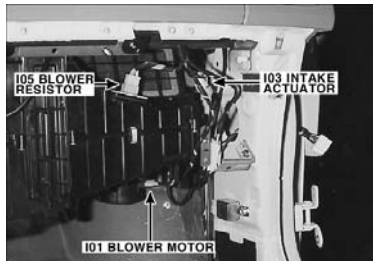

⑤ CONNECTOR VIEW AND NUMBERING ORDER

Female	Male	Remarks
		It is not the shape of the connector housing, but the connector pin that distinguishes between male or female connectors. When numbering female and male connectors, refer to the numbering order in the following table. Some connectors may not follow this method of numbering order. For individual detailed numbering, refer to the CONNECTOR CONFIGURATIONS.
		Numbered in order from upper right to lower left Numbered in order from upper left to lower right

NOTE

UNLESS OTHERWISE STATED, ALL CONNECTOR VIEWS ARE FROM THE TERMINAL SIDE OF THE CONNECTOR.

INTRODUCTION

INTRODUCTION (4)

GI-4

⑥ WIRE COLOR ABBREVIATIONS

The following abbreviations are used to identify wire colors in the circuit schematics.

Symbol	Color of wire	Symbol	Color of wire
B	Black	O	Orange
Br	Brown	P	Pink
G	Green	R	Red
Gr	Gray	W	White
L	Blue	Y	Yellow
Lg	Light Green	Pp	Purple
T	Tawny	Ll	Light Blue

* **Y/B**: Black stripe with yellow ground (2 color)
 ↑ ↑
 the color of the color of
 background stripe

⑦ HARNESS CLASSIFICATION

Electrical wiring connectors are classified according to the wiring data in the Harness Layouts.

Symbol	Harness name	Location
E	Engine, Battery harness	Engine compartment
M	Main, Glove Box EXT. harness	Passenger compartment, Floor
S	Seat harness	Seat
C	Control, Injector, Ignition coil, Oil control valve harness	Engine compartment, Passenger compartment
F	Floor Harness	Floor
R	Roof, Sunroof, Trunk harness	Roof, Trunk
A	Air bag, A/C harness	Under crash pad and Floor
D	Door harness	Door

* It depends on vehicles, it is necessary to check the harness name information on the harness layouts for detailed information.

⑧ CONNECTOR IDENTIFICATION

A connector identification symbol consists of a wiring harness location classification symbol corresponding to a wiring harness location and number corresponding to the connector.

These connector locations can be found in the HARNESS LAYOUTS.

For example:

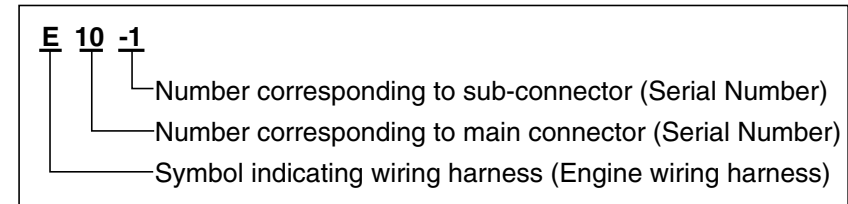

NOTE

Connectors which connect each wiring harness are represented by the following symbols.

For example:

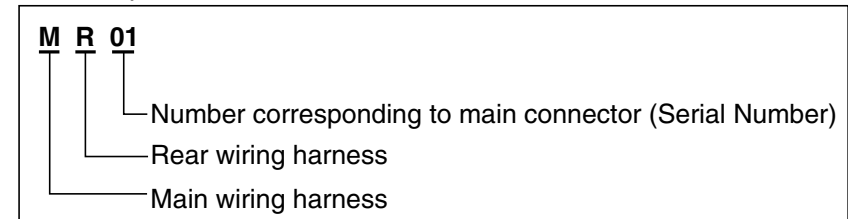

JUNCTION BLOCK IDENTIFICATION

A junction block identification symbol consists of a wiring harness location classification symbol corresponding to a wiring harness location and number corresponding to the connector in the junction block.

For example:

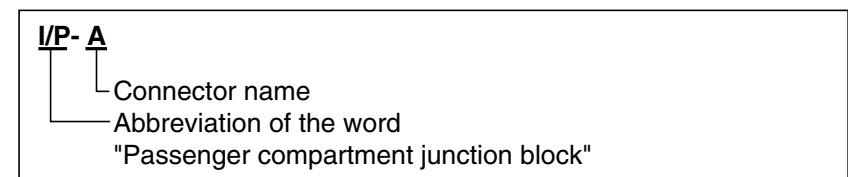

HARNESS LAYOUTS

Harness layouts show the routing of the major wiring harnesses, the in-line connectors and the splices between the major harnesses. These layouts will make electrical troubleshooting easier.

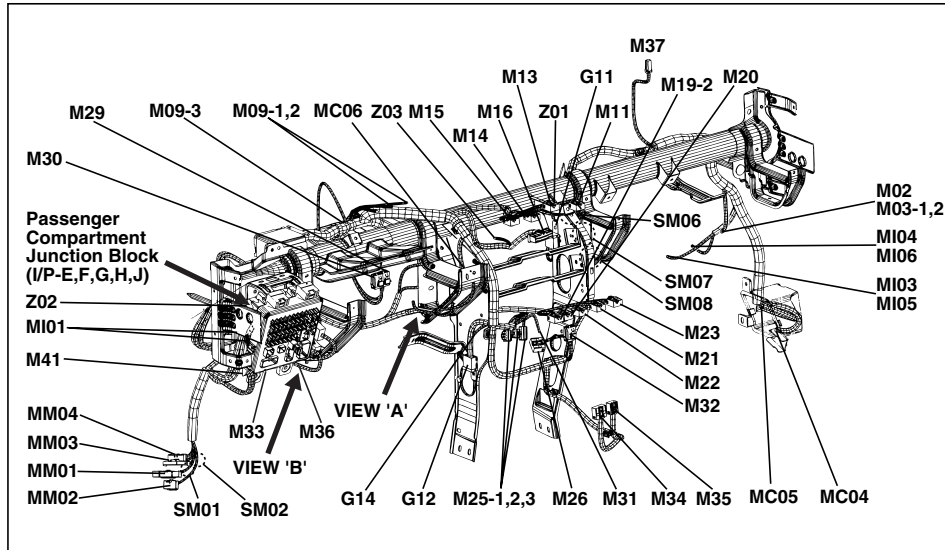











SYMBOLS (1)

Section	Symbol	Meaning	Section	Symbol	Meaning	Section	Symbol	Meaning	Section	Symbol	Meaning
C O M P O N E N T		A solid line means the entire component is shown.	C O N N E C T O R		Shows the name of each connector on the component location index for reference. Indicates the number of corresponding terminal. (Only relevant terminal on the corresponding schematic diagram).	S H I E L D W I R E		This represents RFI (Radio Frequency Interference) Shielding around a wire. The shielding is always connected to ground.	L A M P		Double filament
		A broken line indicates only part of the component is shown.			The dashed-line means each of two wires connect with same connector(E35)			Single filament			
		This means the connector connects directly to the component.	W I R E		A wavy line means the circuit continues, but is not displayed.	J O I N T C O N N E C T O R		This is a connector showing the joining wires.	D I O D E		Diode
		This indicates the connector connects to a lead (pigtail), wired directly to the component.			Wire insulation is yellow with a red strip.			LED			
		This indicates a screw terminal on the component.	S P L I C E S		Current path is continued on the same page or another page. The arrow shows the direction of current flow. You should look for the "A" in the marked position.	S H O W B L O W F U S E		Power supplied Name Capacity	T R		NPN
		This ground symbol (dot and 3 lines overlapping the component) means the housing of the component is attached to a metal part of the vehicle.			A wire connects to another circuit. The wire is shown again on that circuit which the arrow is pointing.			PNP			
		This indicates a screw terminal on the component.	G R O U N D		Wire choices for options or different models are labeled and shown with a "choice" bracket like this.	F U S E		This box indicates the condition under which the circuit is powered. This means the short bar connects to other fuses. Identification Current rating	G E N E R A L C O M P O N E N T S Y M B O L		These switches move together: a dashed line shows a mechanical connection between them.
		The name of the component appears next to its upper right corner. Shows the picture identification number for component location.			Splices are numbered and shown as a dot with circle. The exact location and connection of these splices may vary among vehicles.			Switch (1 contact point)			
	The name of the component appears next to its upper right corner. Shows the picture identification number for component location.			This symbol means the end of the wire is attached to a metal part of the vehicle.	C O N N E C T O R		Control battery power at all times			Heater	

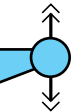
SYMBOLS

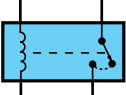
SYMBOLS (2)

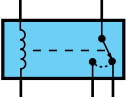
GI-7

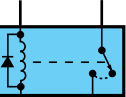
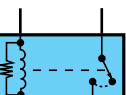
Section	Symbol	Meaning	Section	Symbol	Meaning
GENERAL COMPONENTS SYMBOL		Sensor	GENERAL COMPONENTS SYMBOL		Condenser
		Sender			Speaker
		Injector			Horn, Buzzer, Siren, Chime Bell
		Solenoid	RELAY		Normally open contact
		Motor			This is a relay shown with no current flowing through its coil. When a current flows through coil, contact will toggle.
		Battery			Diode interior relay
				Resistance interior relay	

TROUBLESHOOTING INSTRUCTIONS (1)

GI-8

TROUBLESHOOTING INSTRUCTIONS

TROUBLESHOOTING PROCEDURES

The following five-step troubleshooting procedure is recommended.

1. Verify the customer's complaints

Turn on all the components in the problem circuit to check the accuracy of the customer's complaints. Note the symptoms. Do not begin disassembly or testing until you have narrowed down the probable causes.

2. Read and analyze the schematic diagram

Locate the schematic for the problem circuit. Determine how the circuit is supposed to work by tracing the current paths from the power source through the system components to ground. If you do not understand how the circuit should work, read the circuit operation text. Also check other circuits that share with the problem circuit. The name of circuits that share the same fuse, ground, or switch, for example, are referred to on each diagram. Try to operate any shared circuits you did not check in step 1. If the shared circuit works, the shared wiring is okay, and the cause must be within the wiring used only by the problem circuit.

If several circuits fail at the same time, the fuse or ground is a likely cause.

3. Inspect the circuit/ component with the problem isolated

Make a circuit test to check the diagnosis you made in step 2. Remember that a logical, simple procedure is the key to efficient troubleshooting. Narrow down the probable causes using the troubleshooting hints and system diagnosis charts.

Test for the most likely cause of failure first.

Test circuits by using the easiest point to access that will provide the most information.

4. Repair the problem

Once the problem is found, make the necessary repairs.

5. Verify the Repair

Repeat the system check to be sure you have repaired the problem. If the problem was a blown fuse, be sure to test all of the circuits on that fuse.

TROUBLESHOOTING EQUIPMENT

VOLTMETER AND TEST LAMP

Use a test lamp or a voltmeter on circuits without solid-state units and use a test lamp to check for voltage. A test lamp is made up of a 12-volt light bulb with a pair of leads attached. After grounding one lead, touch the other lead to various points along the circuit where voltage should be present. When the bulb goes on, there is voltage at the point being tested.

CAUTION

A number of circuits include solid-state modules, such as the Engine Control Module(ECM), used with fuel injection.

Voltage in these circuits should be tested only with a 10-megaohm or higher impedance DVOM. Never use a test lamp on circuits that contain solid state modules. Damage to the modules may result.

A voltmeter can be used in place of a test lamp. While a test lamp shows whether the voltage is present or not, a voltmeter indicates how much voltage is present.

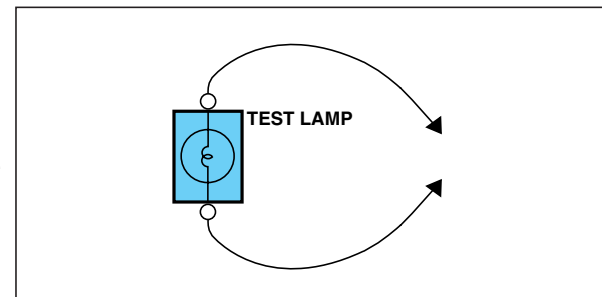
**SELF-POWERED TEST LAMP AND OHMMETER**

Use a self-powered test lamp or an ohmmeter to check for continuity.

The ohmmeter shows how much resistance there is between two points along a circuit. Low resistance means good continuity.

TROUBLESHOOTING INSTRUCTIONS

TROUBLESHOOTING INSTRUCTIONS (2)

GI-9

CAUTION

Never use a self-powered test lamp on circuits that contain solid state modules. Damage to these modules may result.

An ohmmeter can be used in place of a self-powered test lamp. The ohmmeter shows how much resistance there is between two points along a circuit. Low resistance means good continuity.

Circuits which include any solid-state devices should be tested only with a 10-megaohm or higher impedance digital multimeter. When measuring resistance with a digital multimeter, the component being tested should be isolated from the circuit (component disconnected, power OFF). Otherwise, there may be incorrect readings. Diodes and solid-state devices in a circuit can make an ohmmeter give a false reading. To find out if a component is affecting a measurement, take one reading, reverse the leads and take a second reading. If different the solid-state device is affecting the measurement.

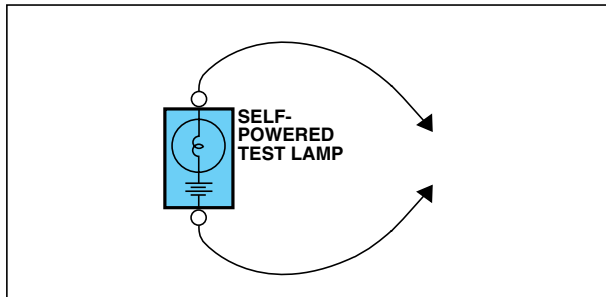

JUMPER WIRE WITH FUSE

Use a jumper wire with a fuse to by-pass an open circuit.

A jumper wire is made up of an in-line fuse holder connected to a set of test leads. This tool is available with small clamp connectors providing adaption to most connectors without damage.

CAUTION

Do not use a fuse with a higher rating than the specified fuse that protects the circuit being tested. Do not use this tool in any situation to substitute an input or output at the solid-state control module, such as ECM, TCM, etc.

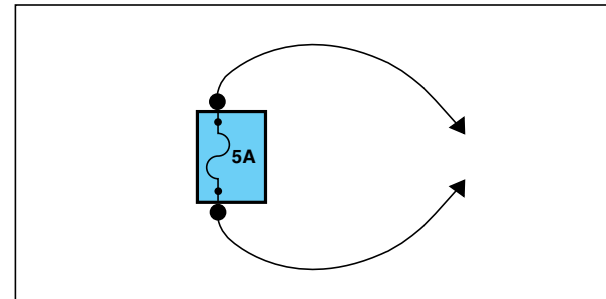

SHORT FINDER

A short finder is available to locate a short to ground. The short finder creates a pulsing magnetic field in the shorted circuit and shows you the location of the short through body trim or sheet metal.

TROUBLESHOOTING TEST

1. TESTING FOR VOLTAGE

This test measures voltage in a circuit. When testing for voltage at a connector, you do not have to separate the two halves of the connector. Instead, probe the connector from the back(backprobe, or use a suitable T-connector). Always check both sides of the connector because dirt and corrosion between its contact surfaces can cause electrical problems.

- A. Connect one lead of a test lamp or voltmeter to a ground. If you are using a voltmeter, be sure it is the voltmeter's negative test lead you have connected to ground.
- B. Connect the other lead of the test lamp or voltmeter to a selected test point(connector or terminal).
- C. If the test lamp glows, there is voltage present. If you are using a voltmeter, note the voltage reading. A loss of more than 1 volt from specification indicates a problem.

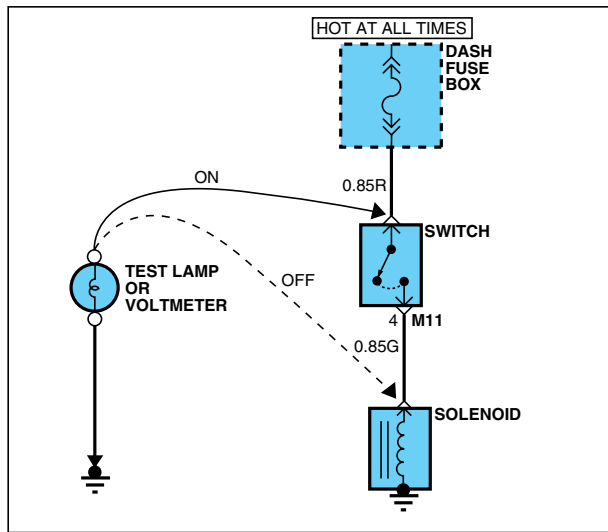

2. TESTING FOR CONTINUITY

- Disconnect the battery negative terminal.
- Connect one lead of a self-powered test lamp or ohmmeter to one end of the part of the circuit you wish to test. If you are using an ohmmeter, hold the leads together and adjust the ohmmeter to read zero ohms.
- Connect the other lead to the other end.
- If the self-power test lamp glows, there is continuity. If you are using an ohmmeter, low or zero resistance means good continuity.

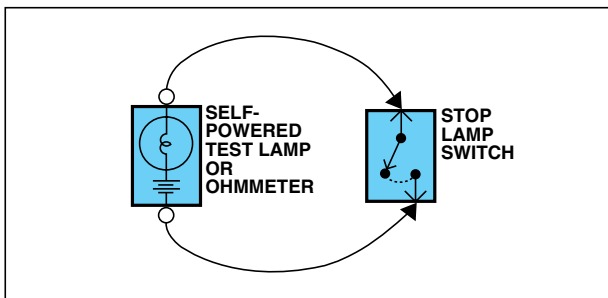

3. TESTING FOR SHORT TO GROUND

- Disconnect the battery negative terminal.
- Connect one lead of a self-powered test lamp or an ohmmeter to the fuse terminal on the load side.
- Connect the other lead to a ground.
- Beginning near the fuse block move the harness from side to side. Continue this procedure (about six inches apart) while watching the self-powered test lamp or ohmmeter.
- When the self-powered test lamp glows, or ohmmeter registers, there is a short to a ground in the wiring near that point.

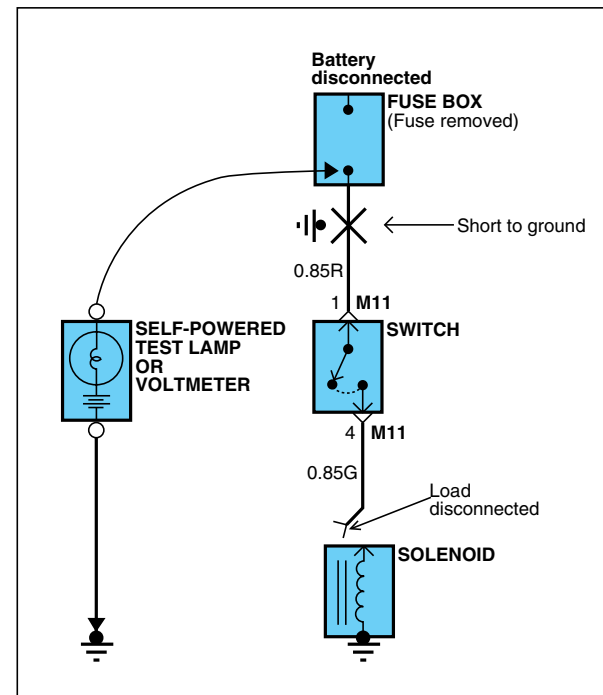

TROUBLESHOOTING INSTRUCTIONS

TROUBLESHOOTING INSTRUCTIONS (4)

GI-11

4. TESTING FOR A SHORT WITH A SHORT FINDER

- Remove the blown fuse. Leave the battery connected.
- Connect the short finder across the fuse terminals.
- Close all switches in series in the circuit that is being testing.
- Turn on the short circuit locator. It sends pulses of current to the short. This creates a pulsing magnetic field around the wiring between the fuse box and the short.
- Beginning at the fuse box, slowly move the short finder along the circuit wiring. The meter will show current pulses through sheet metal and body trim. As long as the meter is between the fuse and the short, the needle will move with each current pulse. Once the meter is moved past the point of the short, the needle will stop moving. Check around this area to locate the cause of the short circuit.

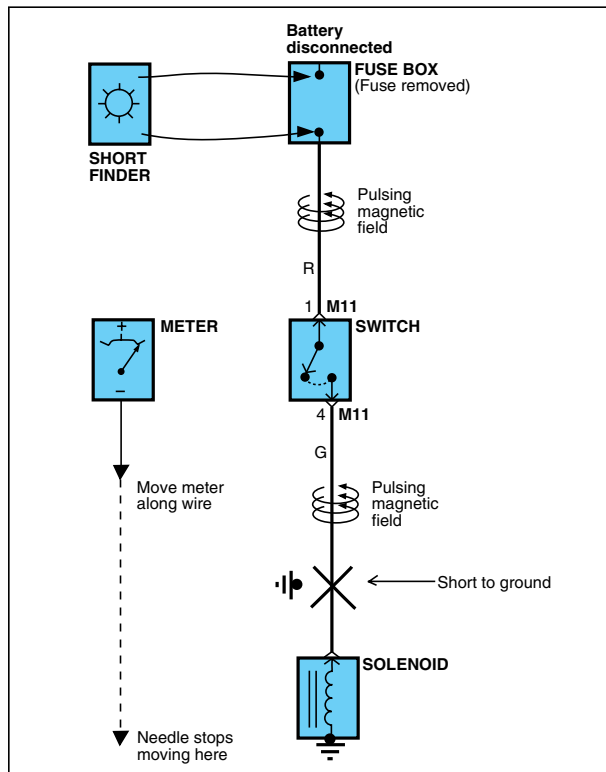

5. TESTING FOR VOLTAGE DROP

This test checks for voltage drop along a wire, or through a connection or switch.

- Connect the positive lead of a voltmeter to the end of the wire (or to the side of the connector or switch) closest to the battery.
- Connect the negative lead to the other end of the wire (or the other side of the connector or switch).
- Operate the circuit.
- The voltmeter will show the difference in voltage between the two points. A difference, or drop of more than 0.1 volts (50mV in 5V circuits), may indicate a problem. Check the circuit for loose or dirty connections.

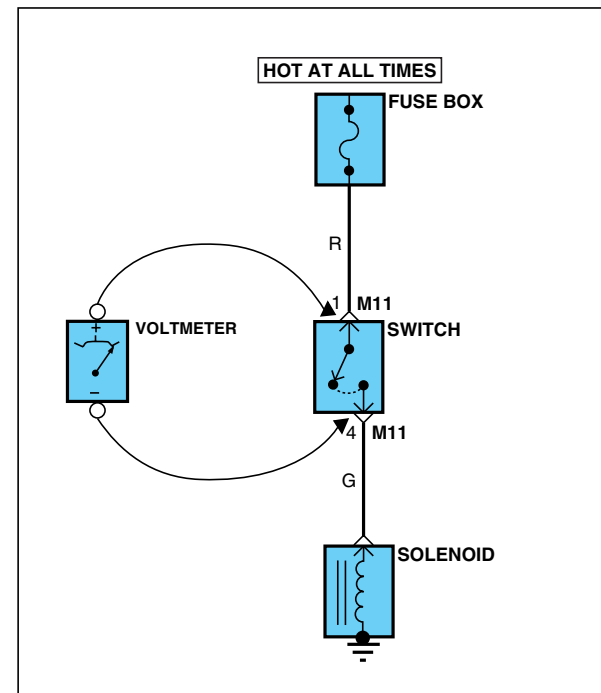

FUSE & RELAY INFORMATIONS (1)

SD100-1

I/P JUNCTION BOX

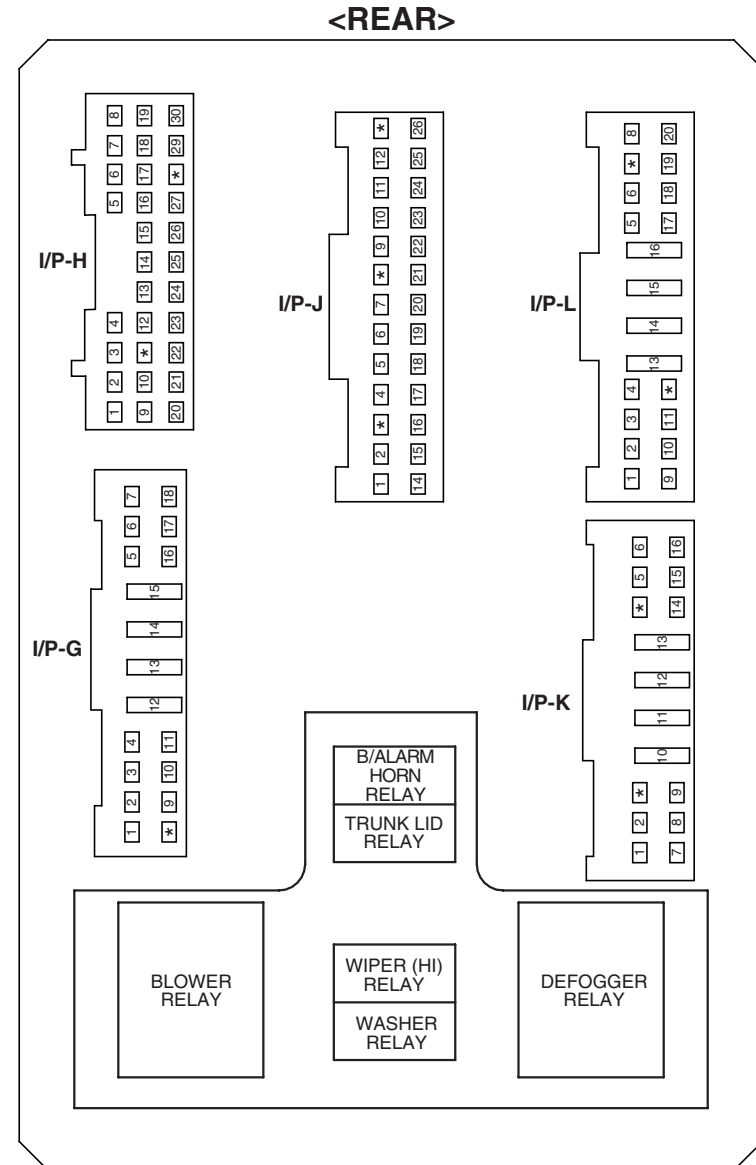
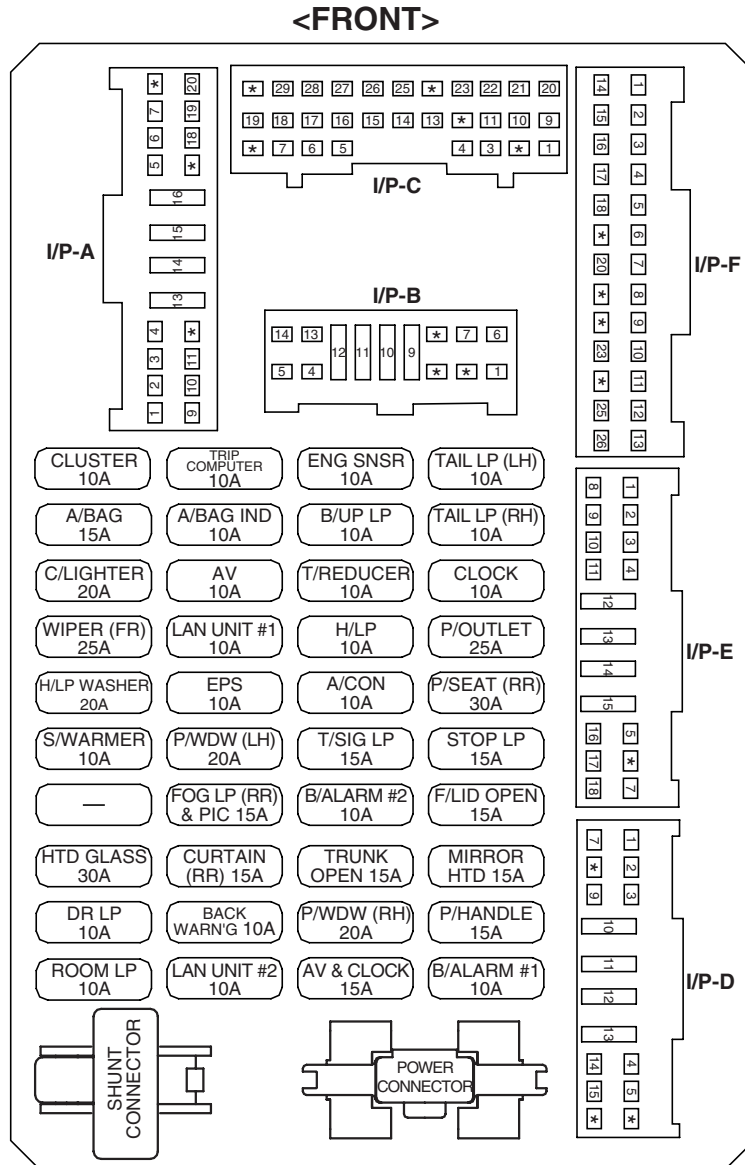

※ USE ONLY DESIGNATED FUSE ONLY

FUSE & RELAY INFORMATIONS

FUSE & RELAY INFORMATIONS (2)

SD100-2

CIRCUIT

FUSE	(A)	Circuit protected
CLUSTER	10A	Instrument Cluster(Indicators), Multifunction Switch, ATM Key Lock Control Module, BCM, ECS Control Module
TRIP COMPUTER	10A	Trip Computer, Stop Lamp Switch, Car Phone, Electro Chromic Mirror, PIC Module, PIC Interface Module, Rain sensor, Steering Angle Sensor
ENG SNSR	10A	PCM, Pulse Generator, Vehicle Speed Sensor
TAIL LP (LH)	10A	Head Lamp LH, Rear Combination Lamp LH, License Lamp LH
A/BAG	15A	SRS Control Module, PAB ON/OFF Switch, Instrument Cluster(PAB OFF Indicator)
A/BAG IND	10A	Instrument Cluster(SRS Indicator)
B/UP LP	10A	Steering Remocon RH, Front & Back warning Switch
TAIL LP (RH)	10A	FOG LP (FR) Relay, Head Lamp RH, Rear Combination Lamp RH, License Lamp RH, Illuminations
C/LIGHTER	20A	Front Cigarette Lighter, Car Phone, Rear Cigaretter Lighter
AV	10A	Audio, Trip Computer
T/REDUCER	10A	Rear Console Switch
CLOCK	10A	Analog Clock, BCM, ATM Key Lock Control Module, PIC Module, PIC Interface Module
WIPER (FR)	25A	Washer Relay, Wiper (Hi) Relay, Wiper Relay, Wiper Motor
LAN UNIT #1	10A	Rheostat, Power Window Switch, Safety Window Module, Power Seat Control Module, Rear Seat Warmer Switch, Rear Console Switch, BCM, Air Purifier Module, Tilt & Telescopic Module
H/LP	10A	H/LP Relay, Head Lamp Leveling Actuator, Head Lamp Leveling Sensor, Air Purifier Switch, AQS Sensor, Head Lamp, Head Lamp Leveling Switch
P/OUTLET	25A	Console Power Outlet, Rear Power Outlet
H/LP WASHER	20A	H/LP Washer Relay
EPS	10A	Rear Curtain Module
A/CON	10A	Blower Relay, A/C Control Module, Sunroof Motor
P/SEAT (RR)	30A	Front Slide Relay, Rear Slide Relay, Rear Slide Limit Switch
S/WARMER	10A	CCS Module, Front Seat Warmer Switch
P/WDW (LH)	20A	Safety Window Module LH
T/SIG LP	15A	BCM, Car Phone
STOP LP	15A	BCM, Stop Lamp Switch
FOG LP (RR) & PIC	15A	RF Receiver, RF Antenna, PIC Key Set Switch, PIC Module
B/ALARM #2	10A	Burglar Alarm Horn Relay, BCM, Burglar Alarm Horn
F/LID OPEN	15A	Fuel Lid Opener & Trunk Lid Switch, Power Window Main Switch, Sports Mode Switch(ATM Solenoid), Front Power Window Switch
HTD GLASS	30A	Defogger Relay, BCM, Rear Defogger, HTD Glass Relay
CURTAIN (RR)	15A	ADJ Pedal Relay, Key Solenoid, Rear Curtain Module
TRUNK OPEN	15A	Trunk Lid Relay, Power Window Switch, Trunk Lid Main Switch, Trunk Lid Latch
MIRROR HTD	15A	HTD Glass Relay
DR LP	10A	Front Foot Lamp, Ignition Key ILL. & Door Warning Switch, Instrument Cluster(Door Open/Trunk Open Indicator), Door Lamp, Trunk Room Lamp
BACK WARN'G	10A	Multipurpose Check Connector, Data Link Connector, A/C Control Module, Front & Back Warning Buzzer
P/WDW (RH)	20A	Safety Window Module RH
P/HANDLE	15A	Tilt & Telescopic Module, PIC Interface Module
ROOM LP	10A	Room Lamp, Sunvisor Lamp, Map Lamp, Sunroof Switch
LAN UNIT #2	10A	Multifunction Switch, Power Seat Control Module, Power Window Switch, Front Power Seat Switch LH, Front PIC Outside Handle, Rear Curtain Module, Tilt & Telescopic Module
AV & CLOCK	15A	Trip Computer, Analog Clock, Audio
B/ALARM #1	10A	BCM

FUSE & RELAY INFORMATIONS

FUSE & RELAY INFORMATIONS (3)

SD100-3

E/R JUNCTION BOX

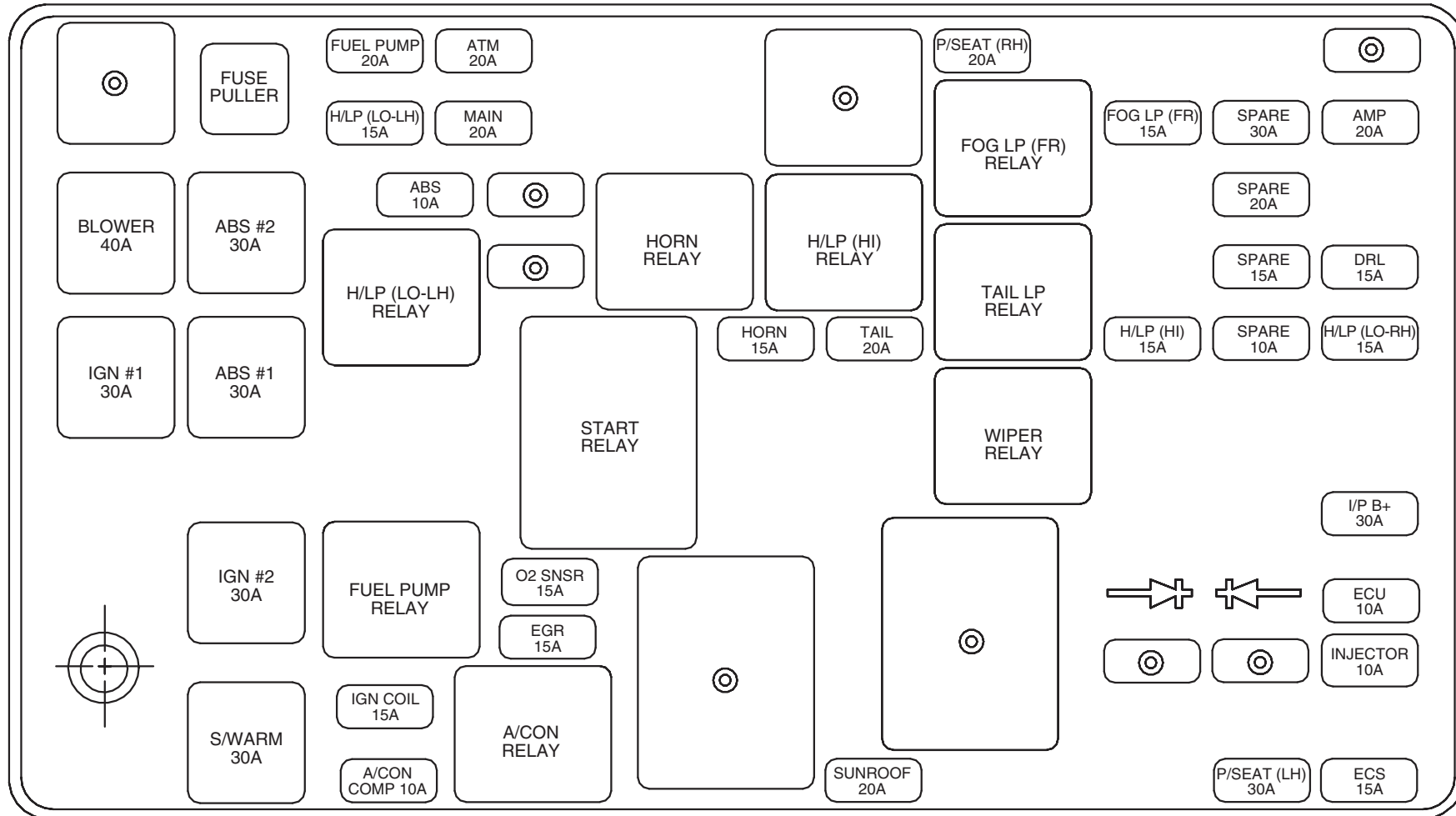

✘ USE ONLY DESIGNATED FUSE AND RELAY ONLY

FUSE & RELAY INFORMATIONS

FUSE & RELAY INFORMATIONS (4)

SD100-4

CIRCUIT

FUSE & FUSIBLE LINK	(A)	Circuit protected
FUEL PUMP	20A	Fuel Pump Relay
H/LP (LO-LH)	15A	H/LP (LO-LH) Relay
ABS	10A	Multipurpose Check Connector, ABS/ESP Control Module
IGN COIL	15A	Ignition Coil #1~#6, Condenser
A/CON COMP	10A	A/CON Relay
ATM	20A	ATM Control Relay
MAIN	20A	Engine Control Relay, PCM
O2 SNSR	15A	Oxygen Sensor #1~#4, Cooling Fan Relay, PCM
EGR	15A	A/CON Relay, Oil Control Valve, Air Flow Sensor, Purge Control Valve, Variable Intake Valve, Immobilizer Module
HORN	15A	Horn Relay
TAIL	20A	TAIL LP Relay
SUNROOF	20A	Sunroof Motor
P/SEAT (RH)	20A	Front Power Seat Relay Box, Front Slide Limit Switch RH, Front Recline Limit Switch RH
FOG LP (FR)	15A	FOG LP (FR) Relay
H/LP (HI)	15A	H/LP (HI) Relay
P/SEAT (LH)	30A	Power Seat Control Module, Front Lumbar Support Switch LH
AMP	20A	JBL Amp
DRL	15A	DRL Relay
H/LP (LO-RH)	15A	H/LP (LO-RH) Relay, Front Turn Signal Lamp
I/P B+	30A	I/P Junction Box Fuse
ECU	10A	PCM
INJECTOR	10A	Injector #1~#6
ECS	15A	ECS Relay
IGN #1 Fusible Link	30A	Ignition Switch
IGN #2 Fusible Link	30A	Ignition Switch, Start Relay
ABS #1 Fusible Link	30A	ABS/ESP Control Module
ABS #2 Fusible Link	30A	ABS/ESP Control Module
S/WARM Fusible Link	30A	CCS Blower Motor, CCS Module, Seat Warmer Module
BLOWER Fusible Link	40A	Blower Relay

FUSE & RELAY INFORMATIONS

FUSE & RELAY INFORMATIONS (5)

SD100-5

E/R FUSIBLE LINK BOX

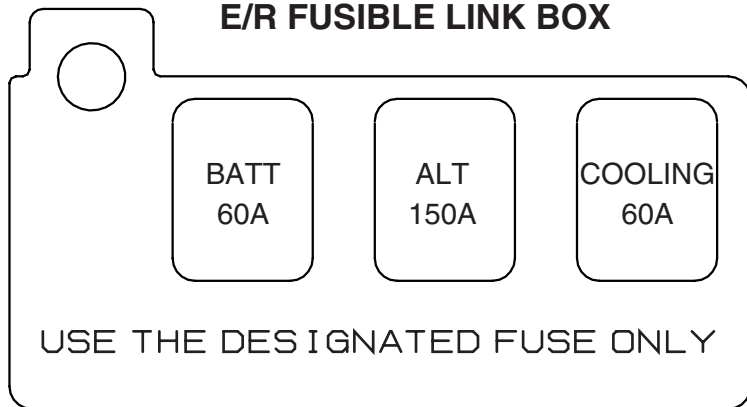

I/P RELAY BOX

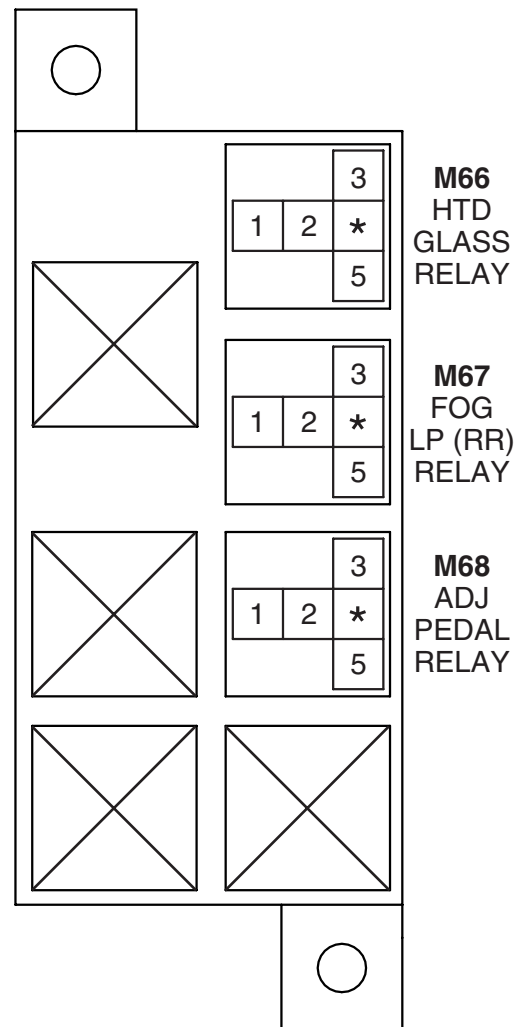

E/R RELAY BOX

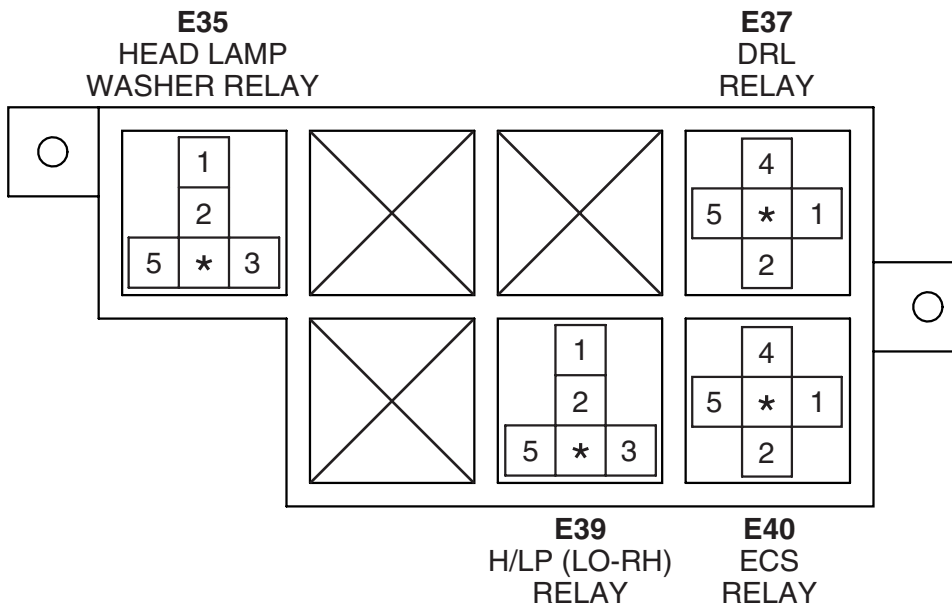

FUSE & RELAY INFORMATIONS

FUSE & RELAY INFORMATIONS (6)

SD100-6

MEMO

POWER DISTRIBUTION

POWER DISTRIBUTION (3)

SD110-3

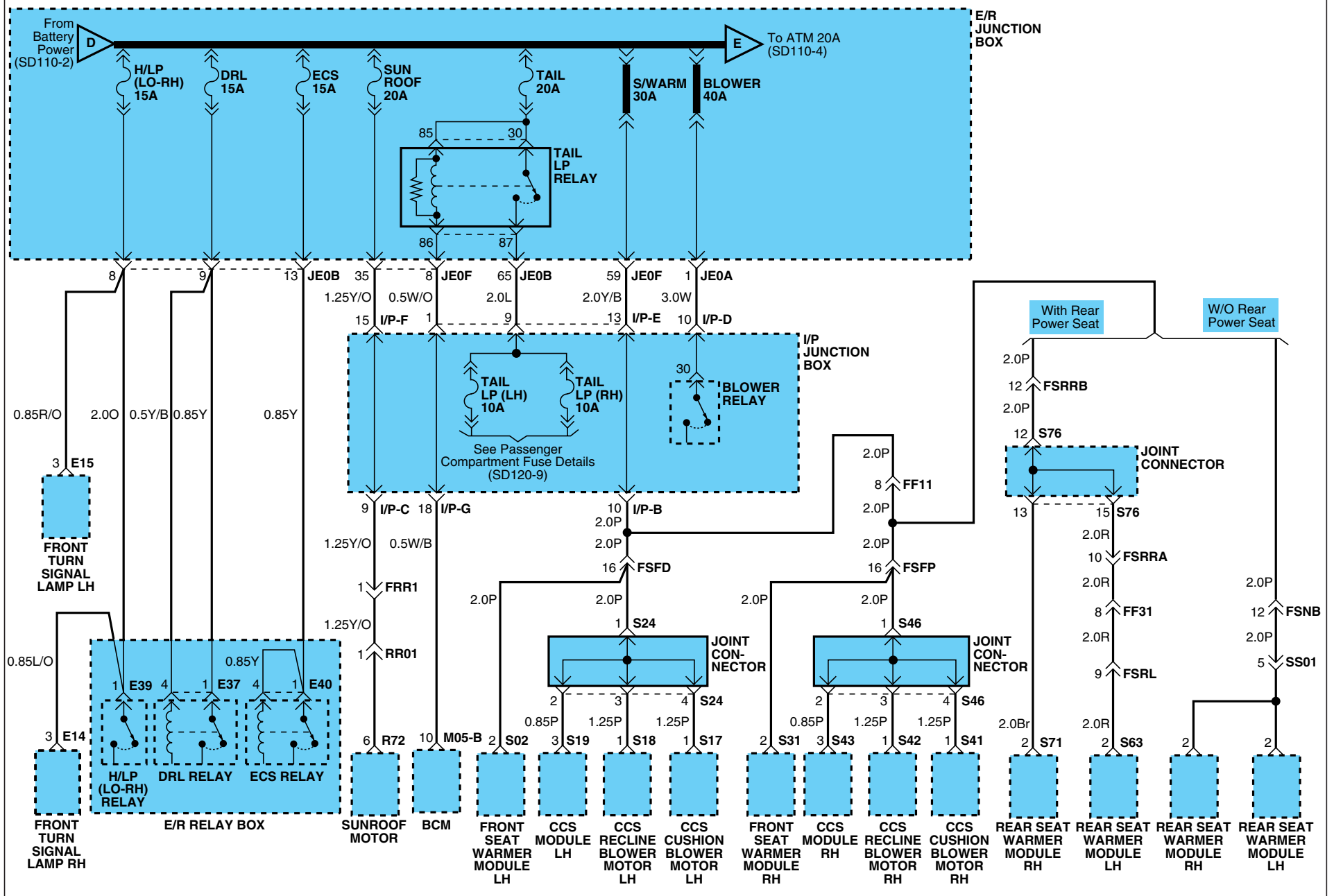

POWER DISTRIBUTION

POWER DISTRIBUTION (4)

SD110-4

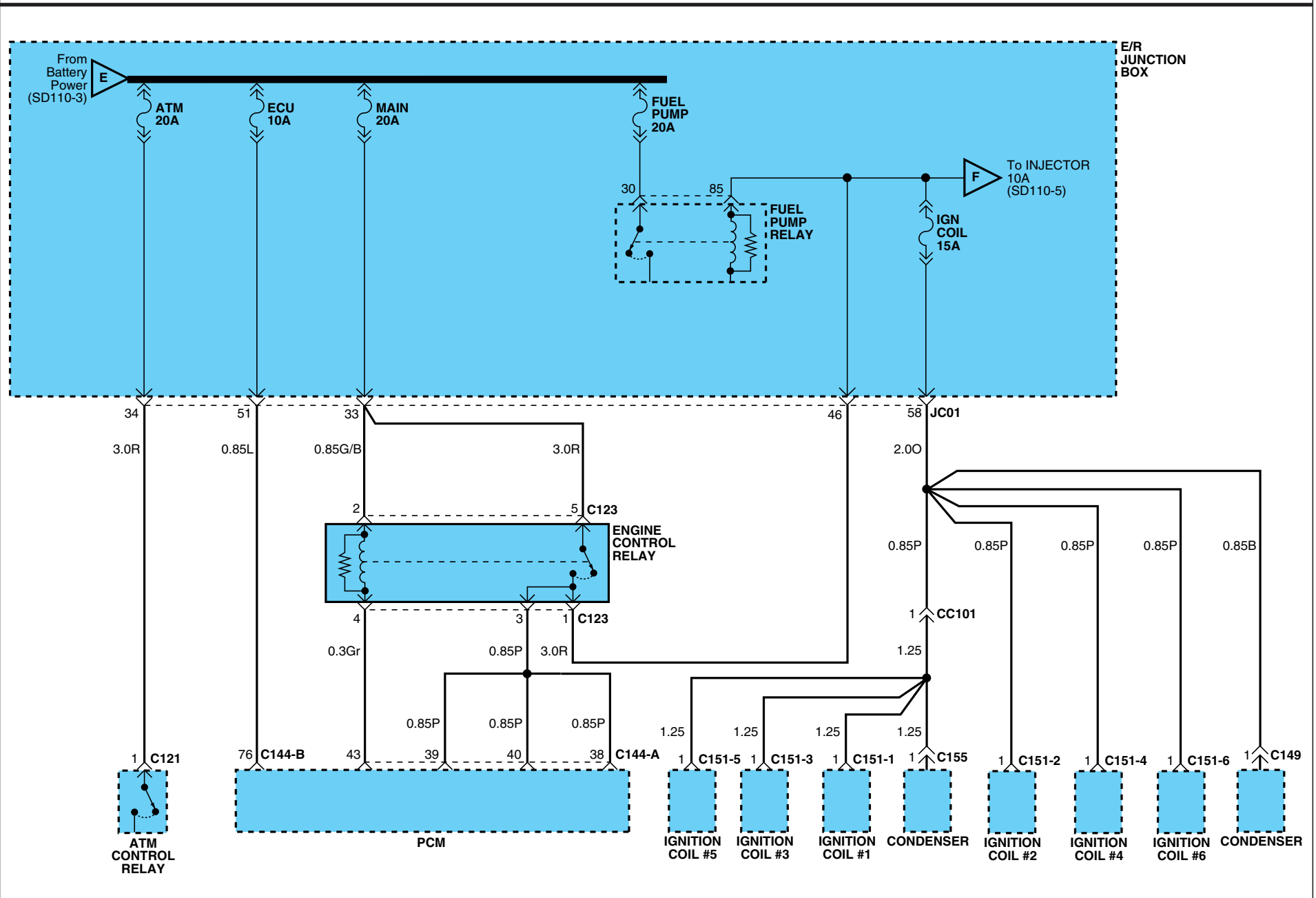

POWER DISTRIBUTION

POWER DISTRIBUTION (5)

SD110-5

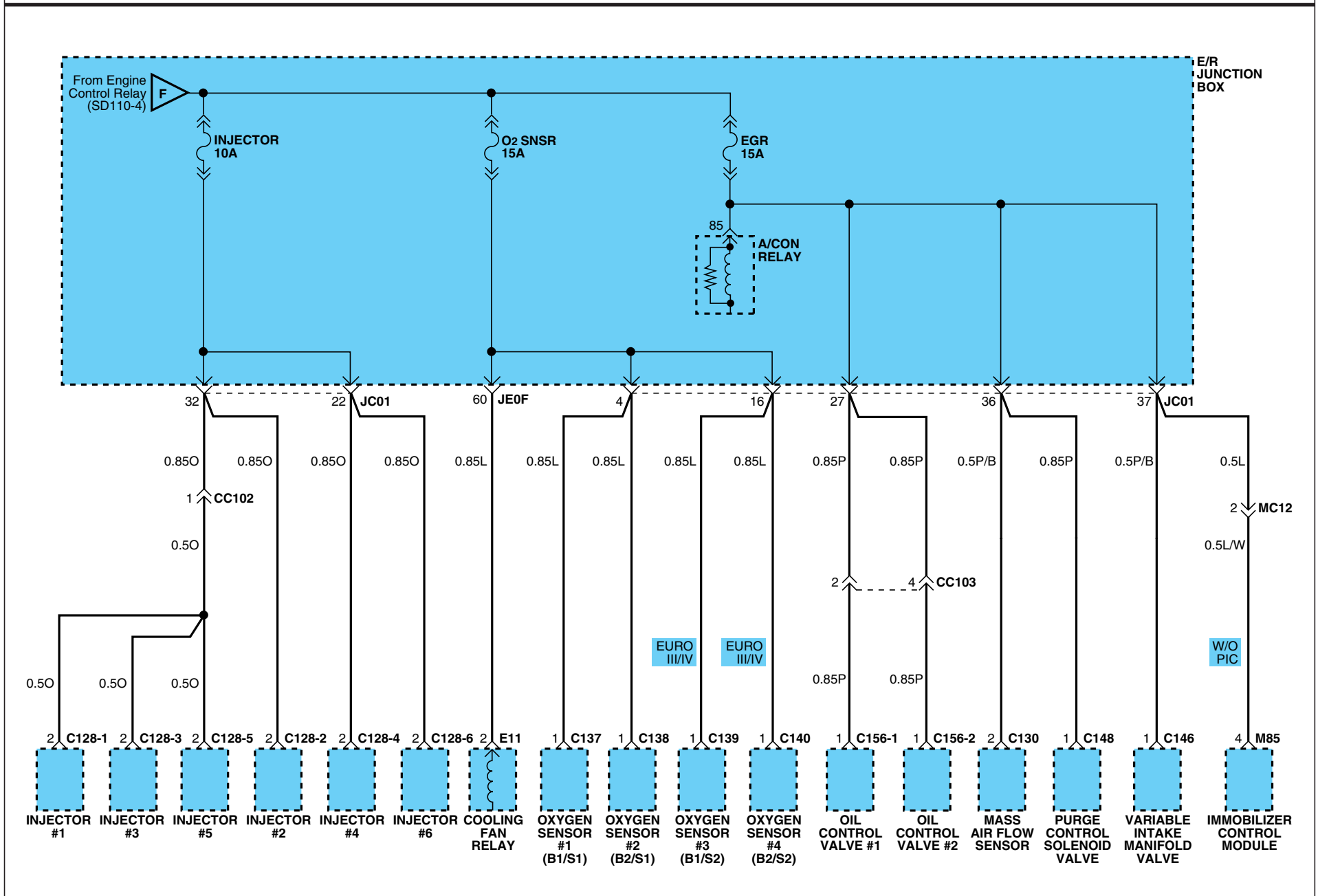

POWER DISTRIBUTION

POWER DISTRIBUTION (6)

SD110-6

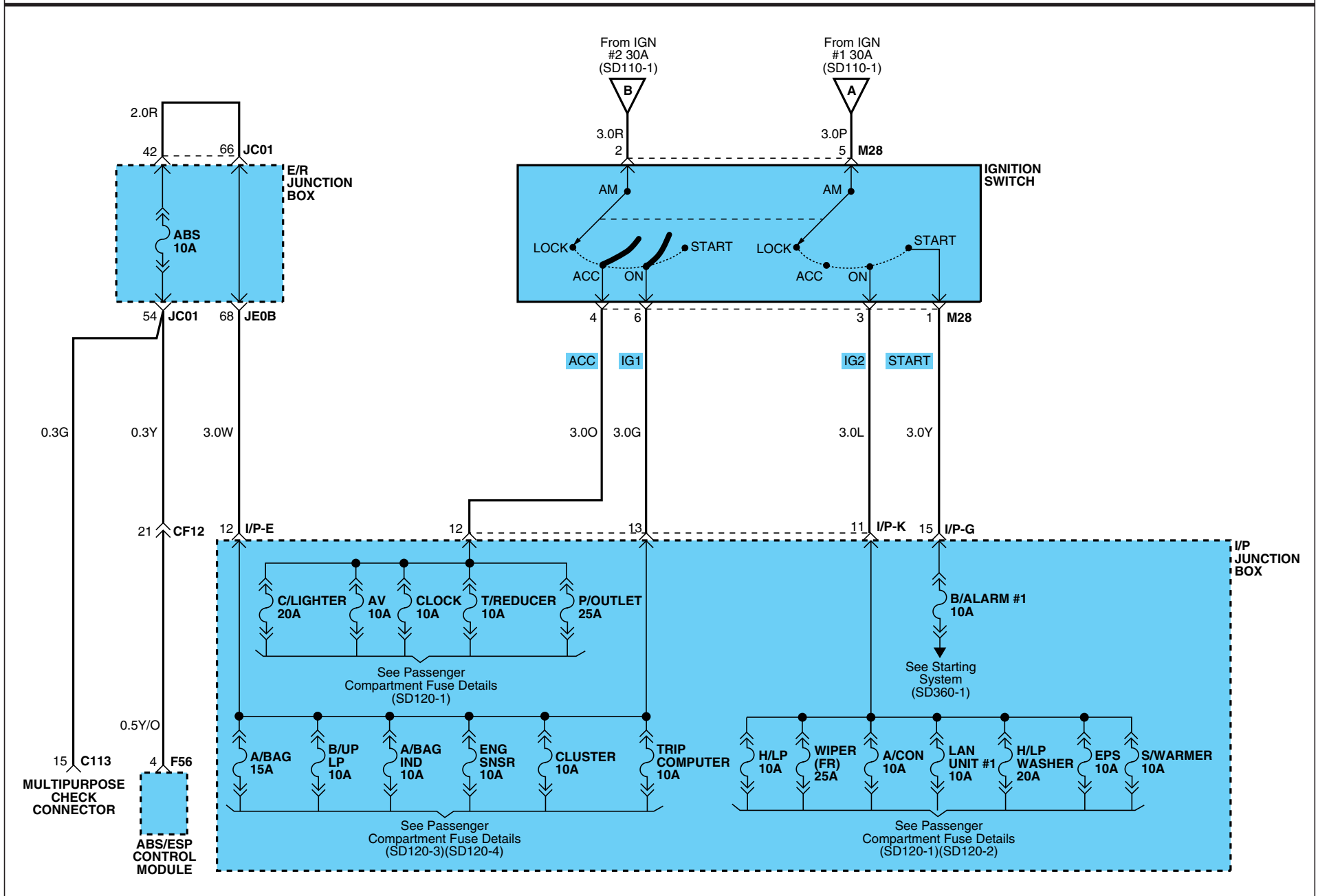

PASSENGER COMPARTMENT FUSE DETAILS (1)

SD120-1

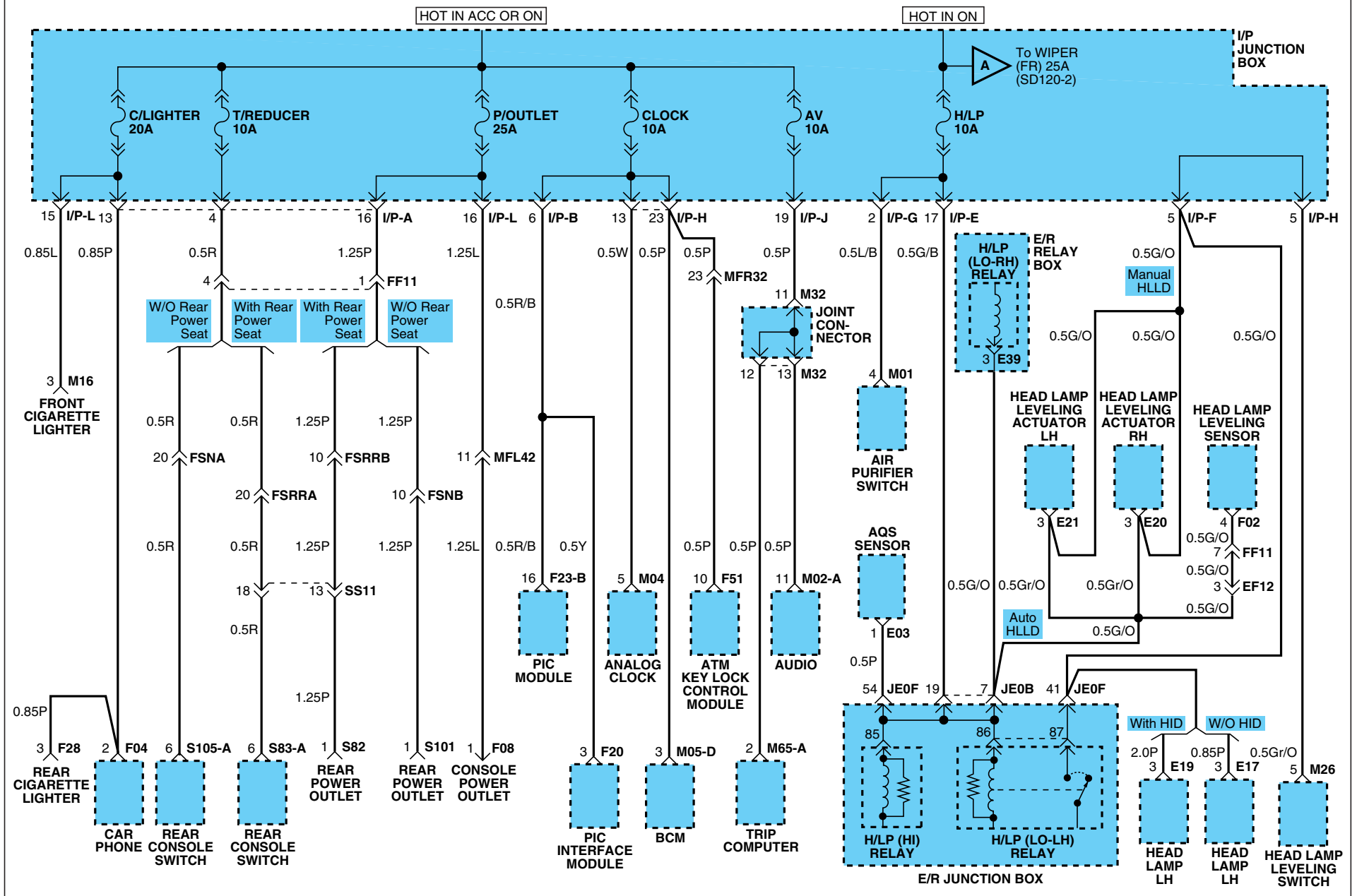

PASSENGER COMPARTMENT FUSE DETAILS

PASSENGER COMPARTMENT FUSE DETAILS (2)

SD120-2

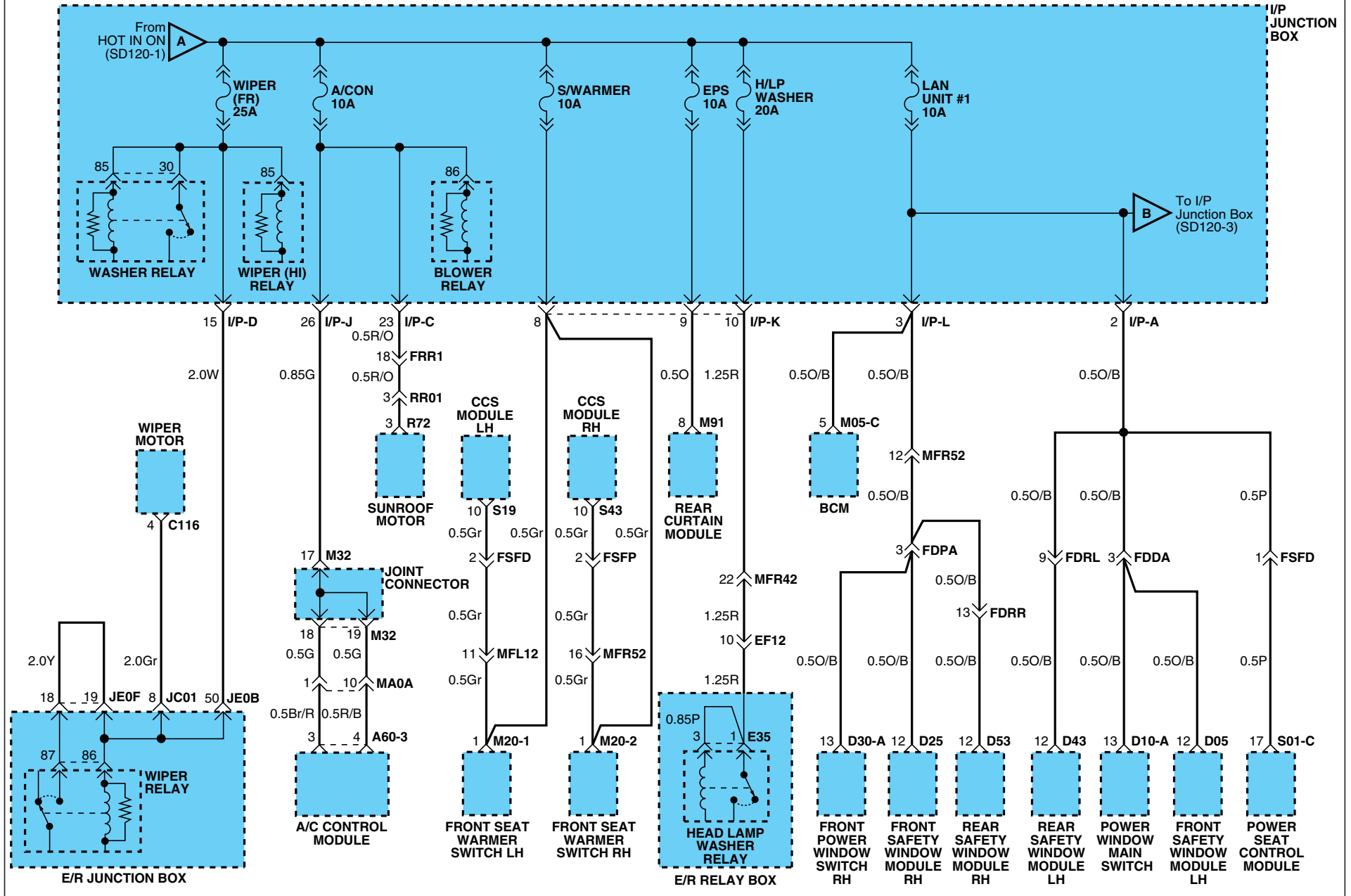

PASSENGER COMPARTMENT FUSE DETAILS

PASSENGER COMPARTMENT FUSE DETAILS (3)

SD120-3

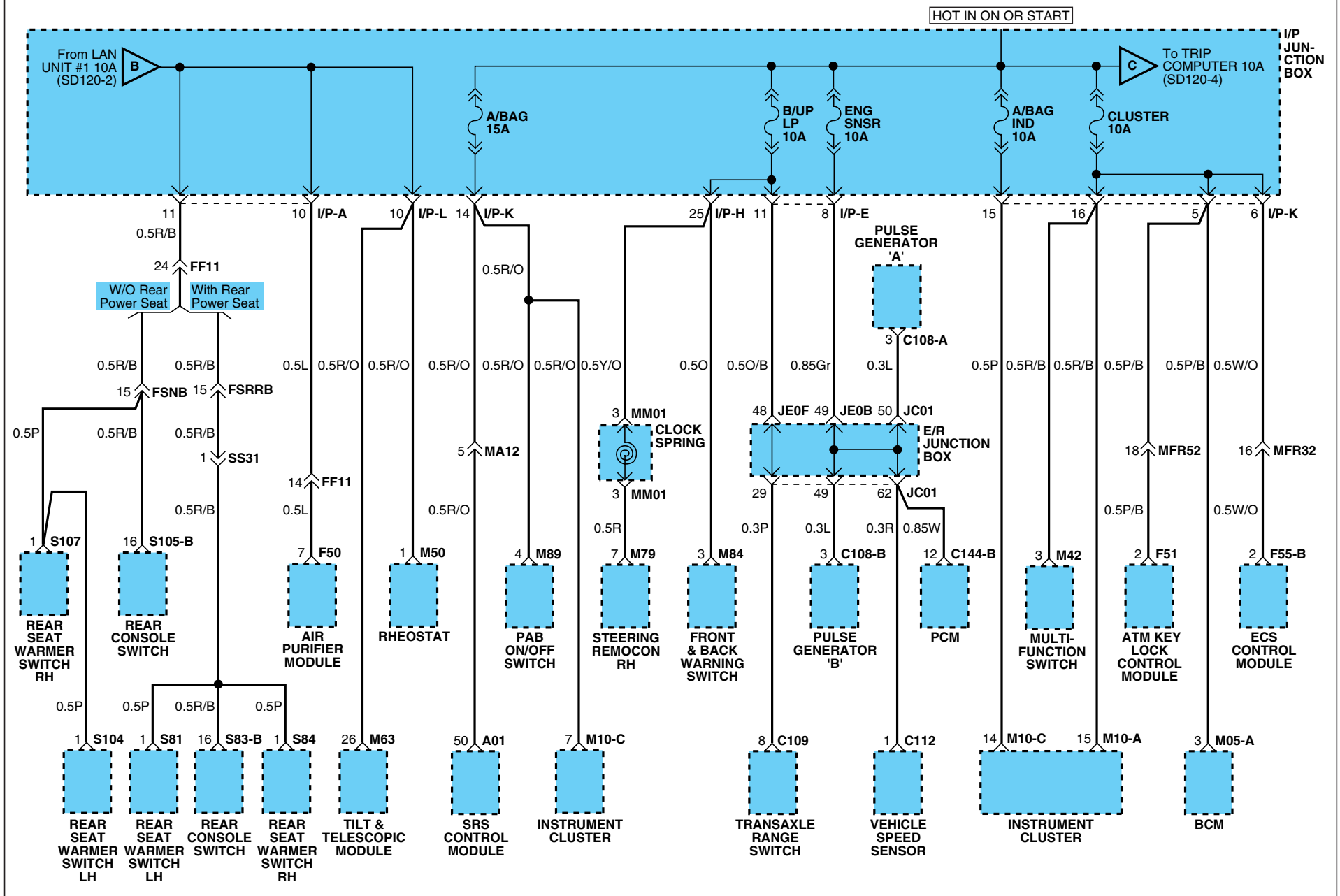

PASSENGER COMPARTMENT FUSE DETAILS

PASSENGER COMPARTMENT FUSE DETAILS (5)

SD120-5

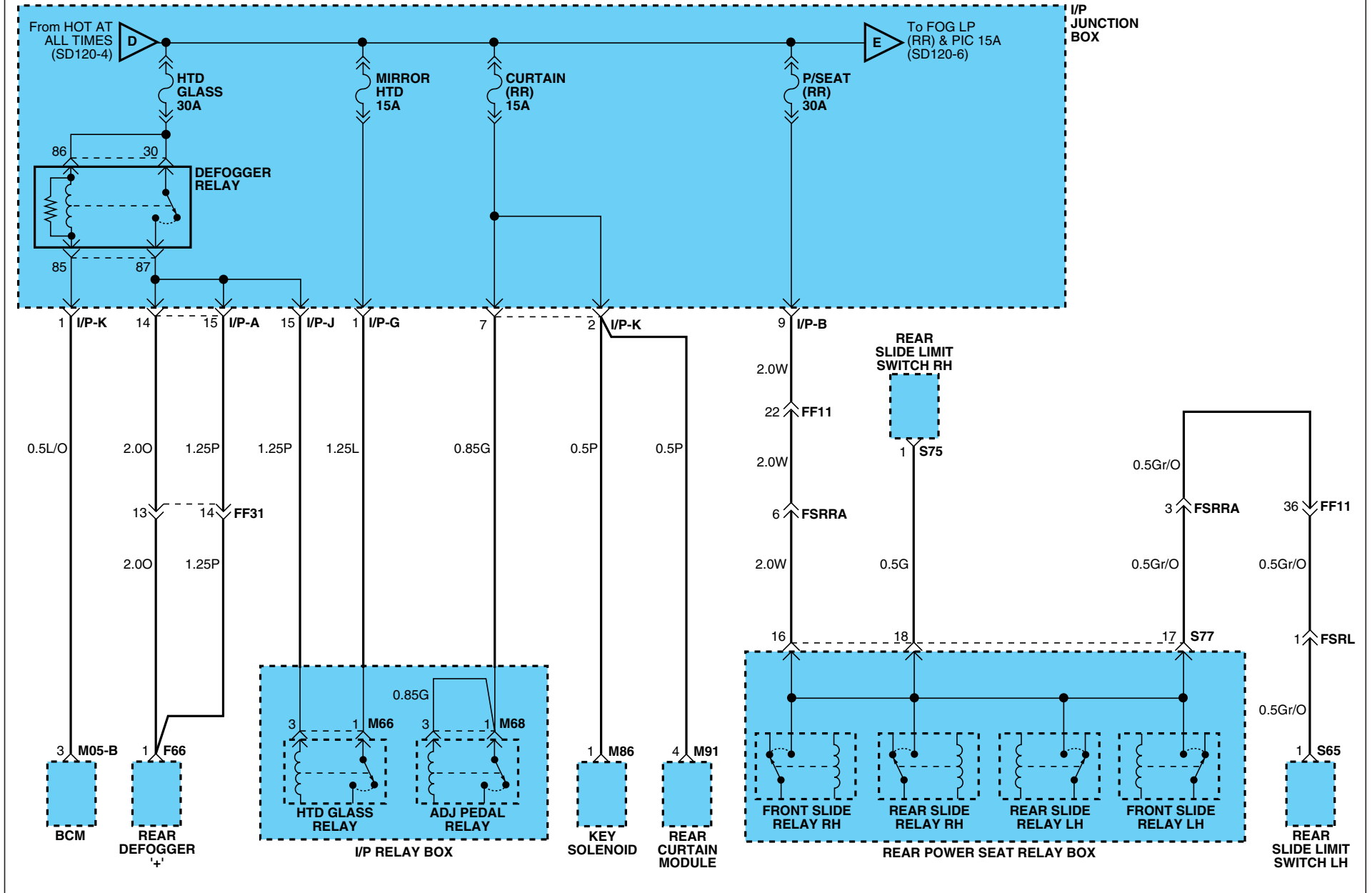

PASSENGER COMPARTMENT FUSE DETAILS

PASSENGER COMPARTMENT FUSE DETAILS (6)

SD120-6

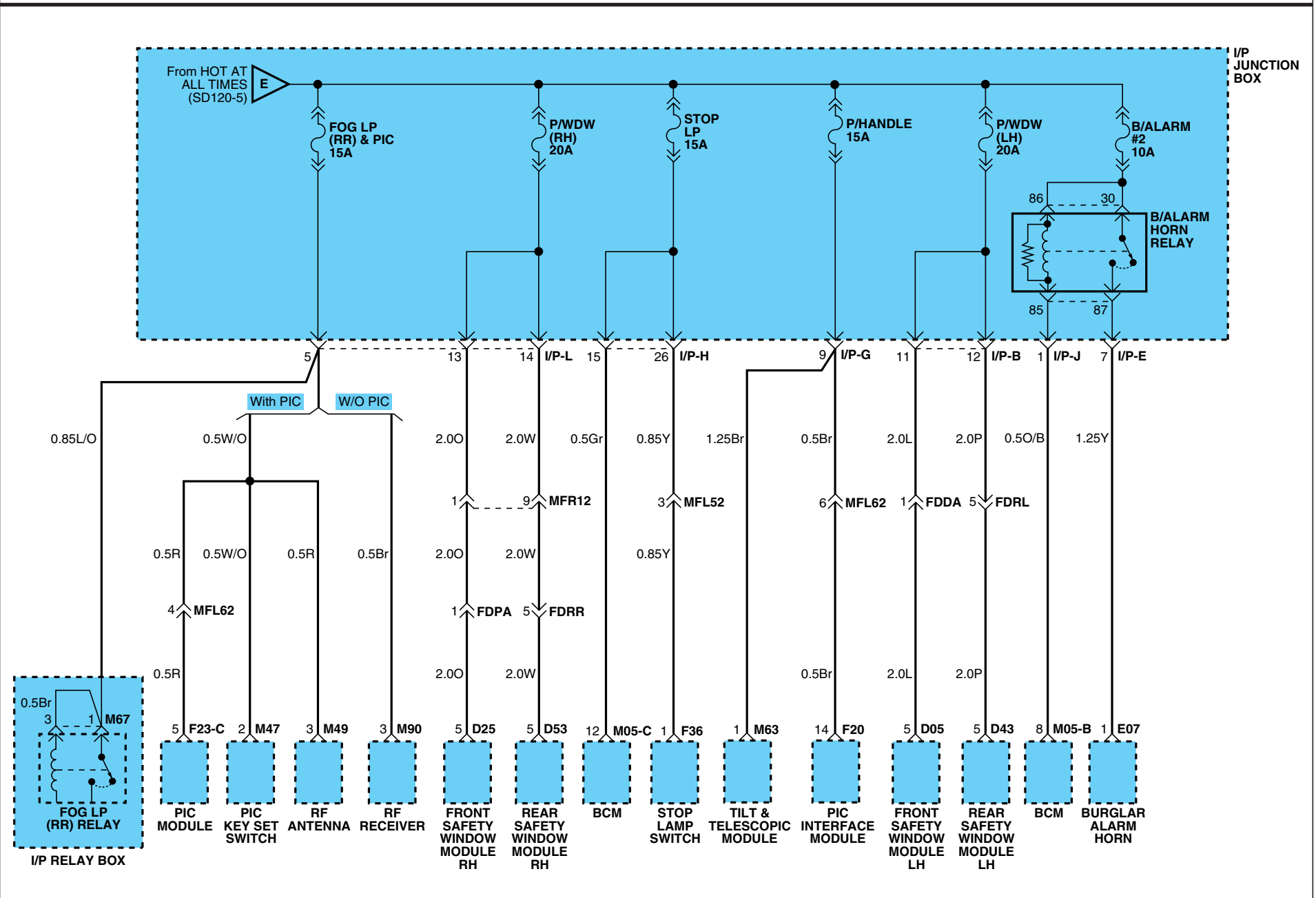

PASSENGER COMPARTMENT FUSE DETAILS

PASSENGER COMPARTMENT FUSE DETAILS (8)

SD120-8

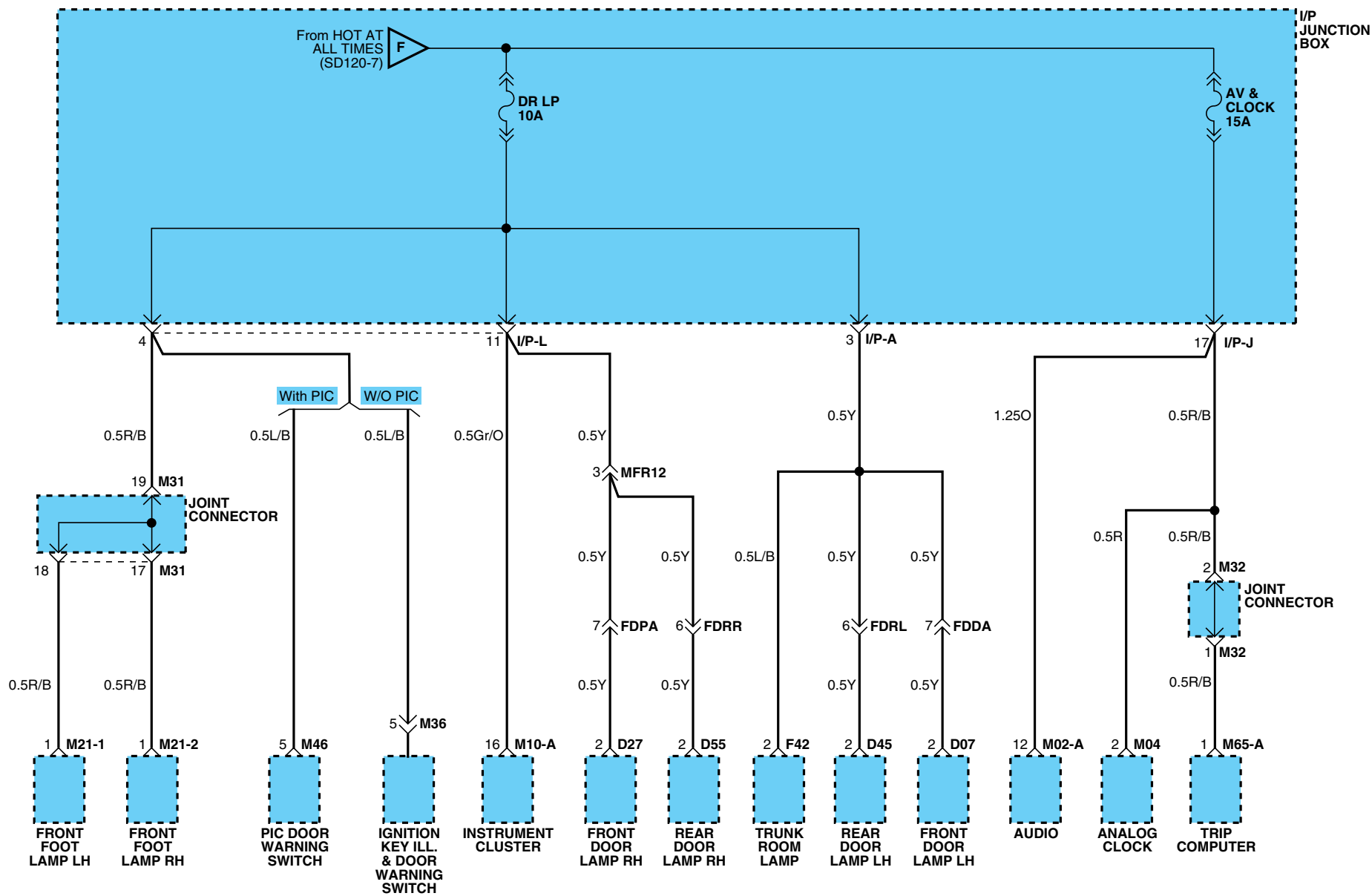

PASSENGER COMPARTMENT FUSE DETAILS

PASSENGER COMPARTMENT FUSE DETAILS (10)

SD120-10

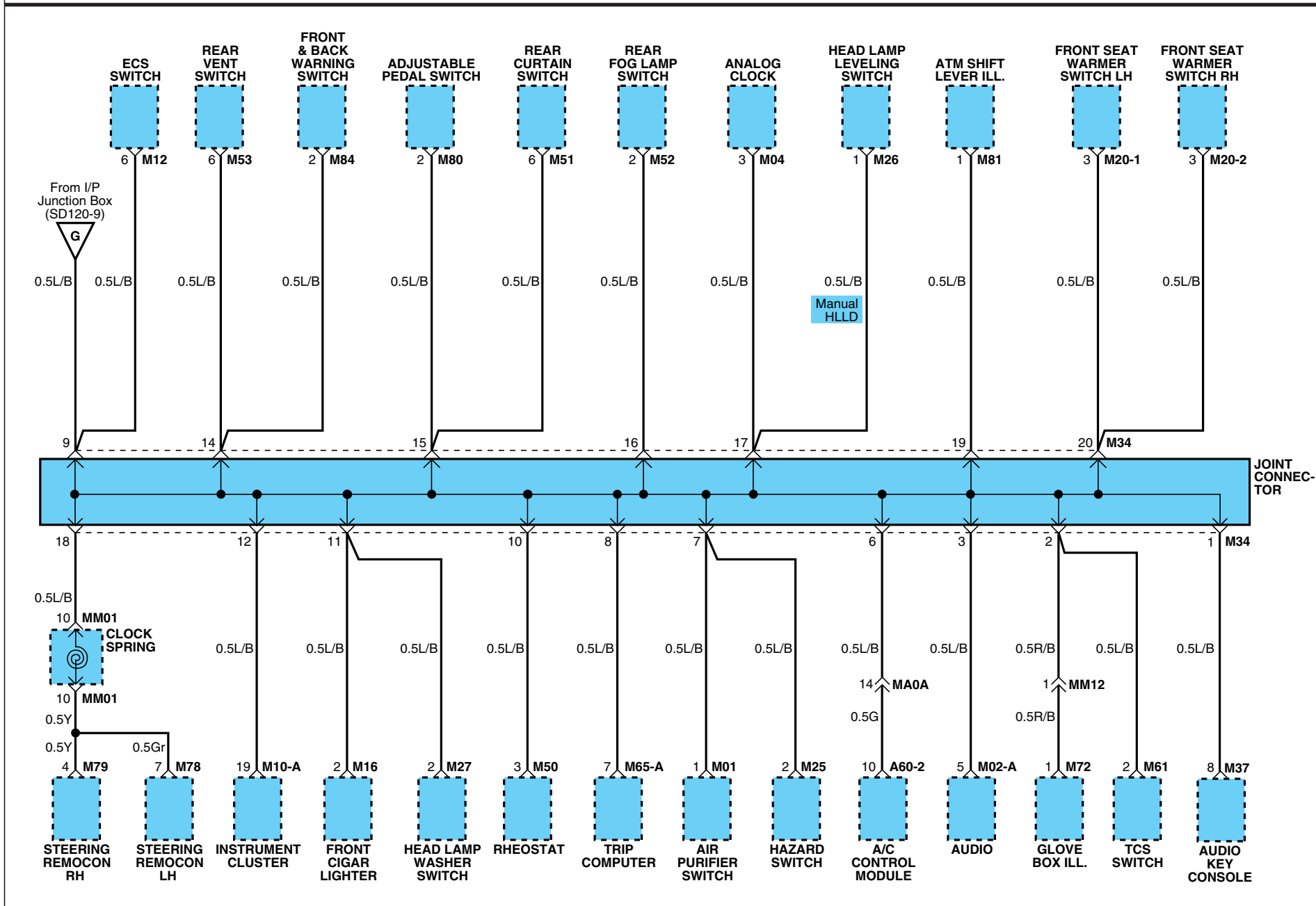

GROUND DISTRIBUTION (1)

SD130-1

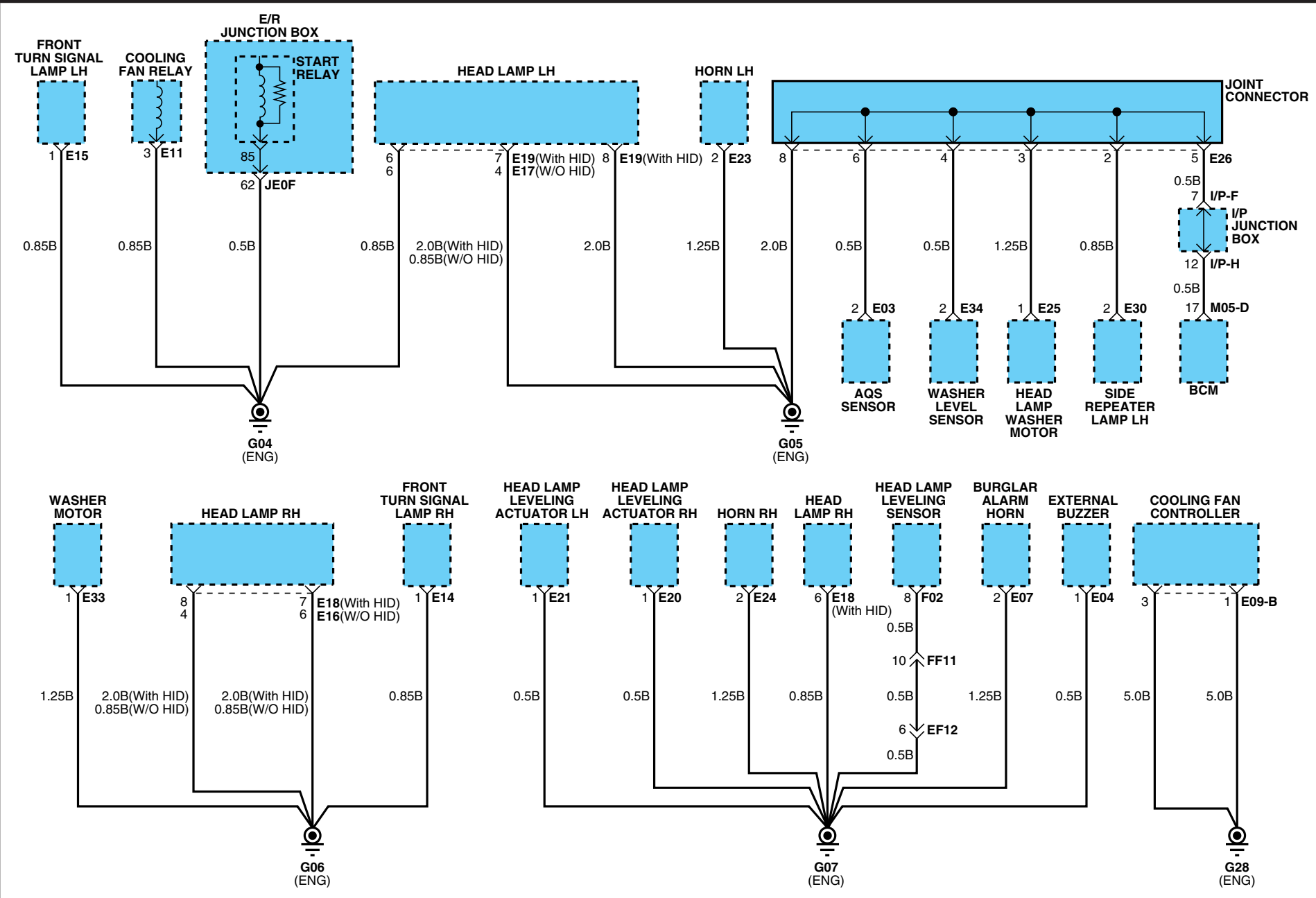

GROUND DISTRIBUTION

GROUND DISTRIBUTION (2)

SD130-2

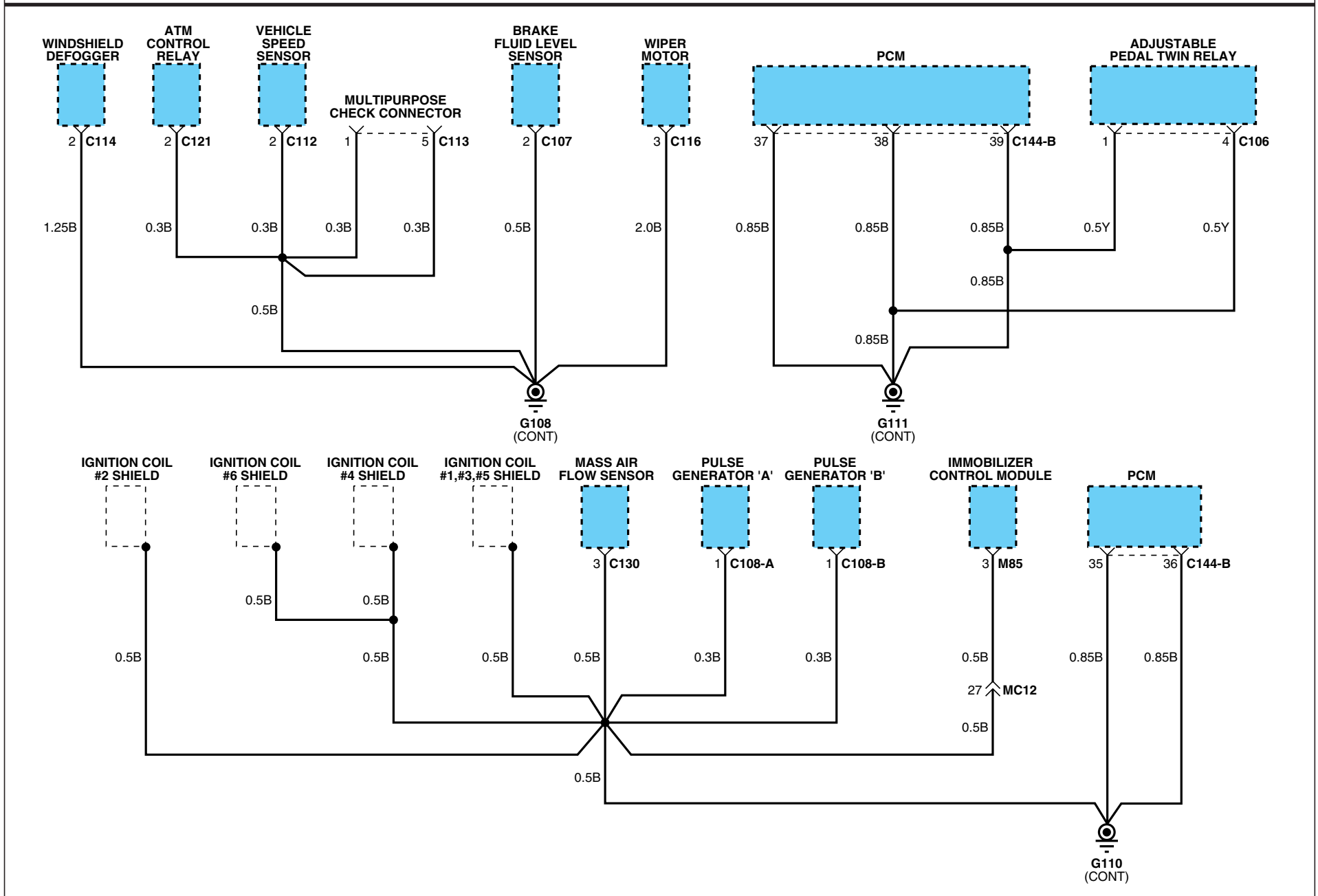

GROUND DISTRIBUTION

GROUND DISTRIBUTION (3)

SD130-3

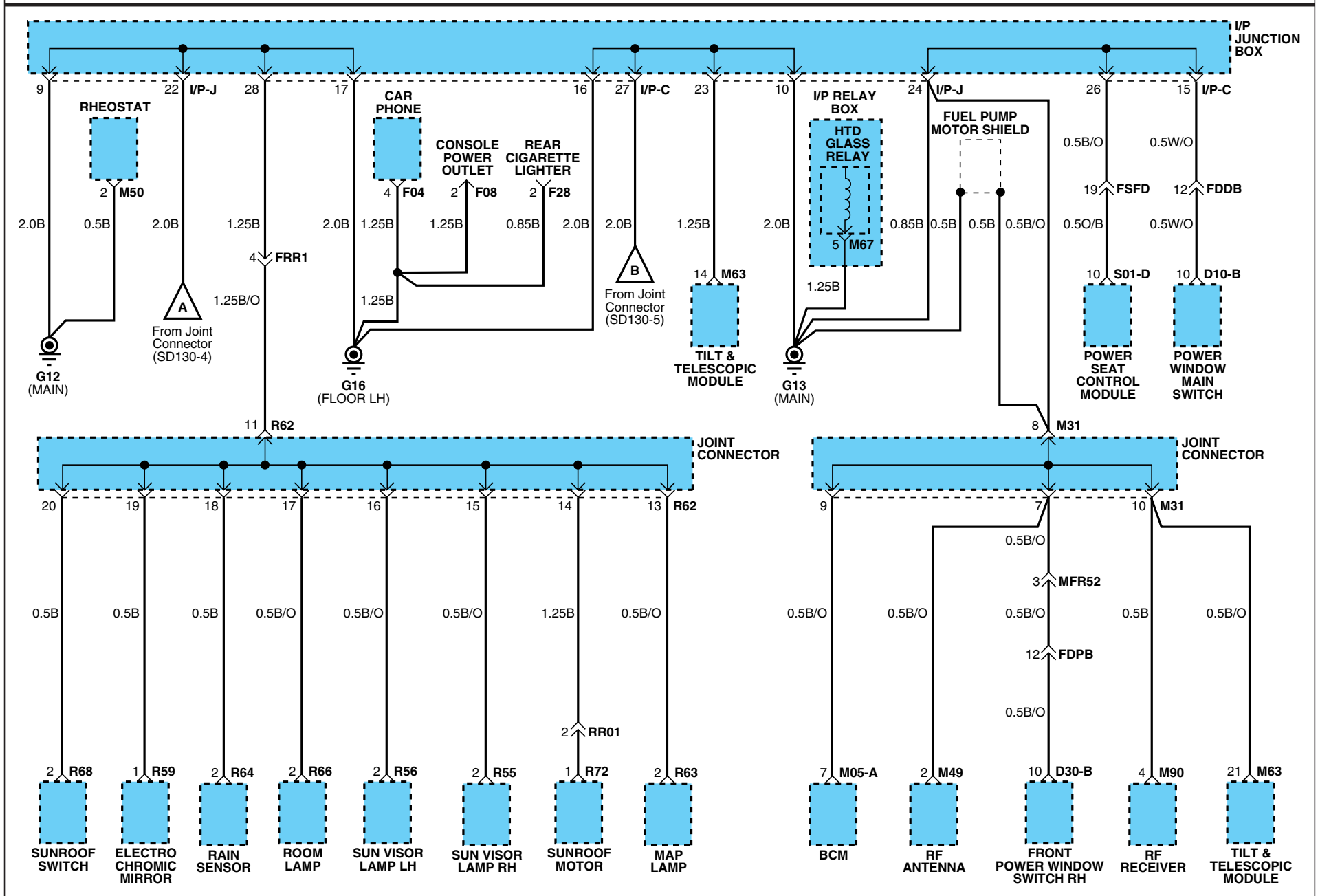

GROUND DISTRIBUTION

GROUND DISTRIBUTION (4)

SD130-4

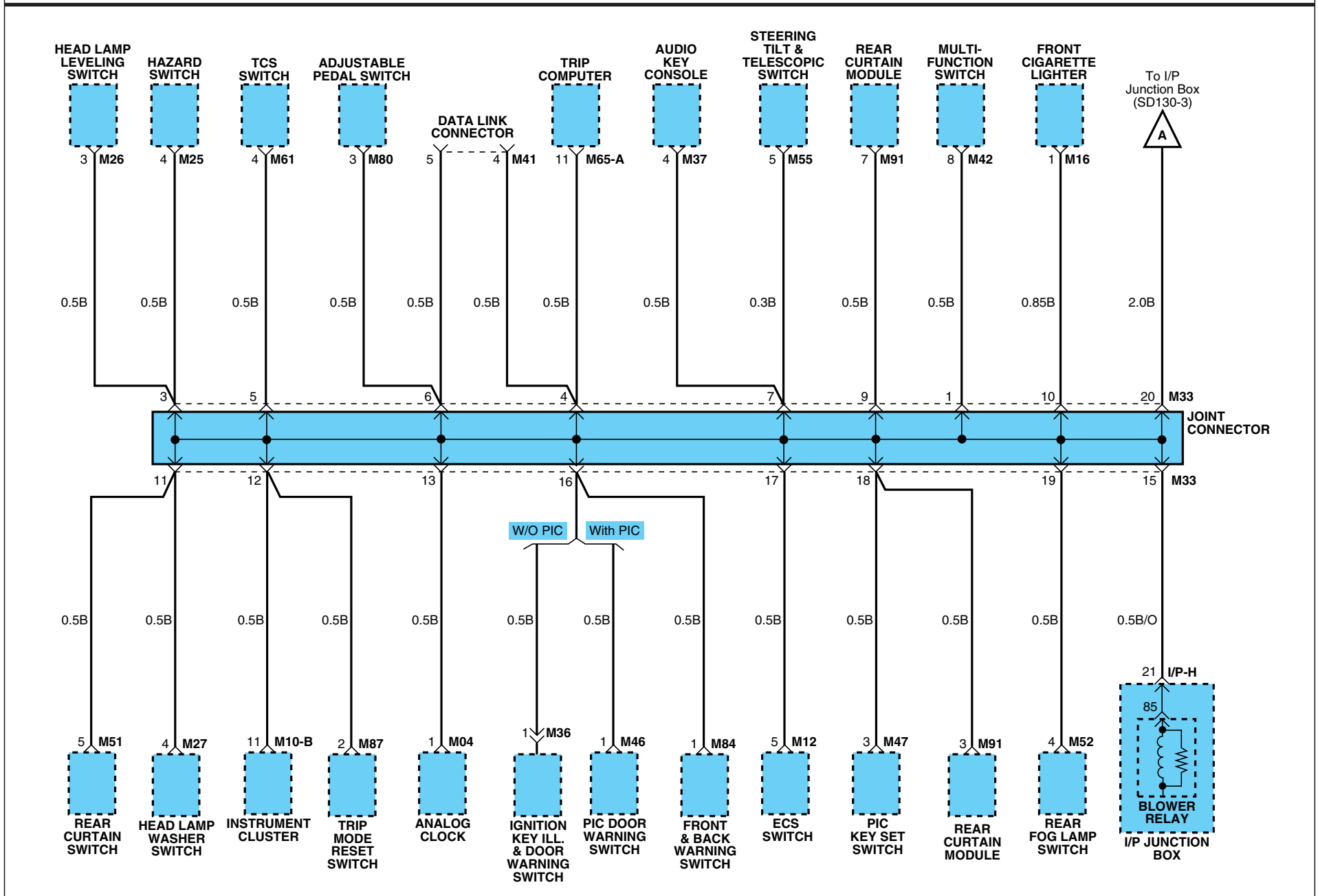

GROUND DISTRIBUTION

GROUND DISTRIBUTION (5)

SD130-5

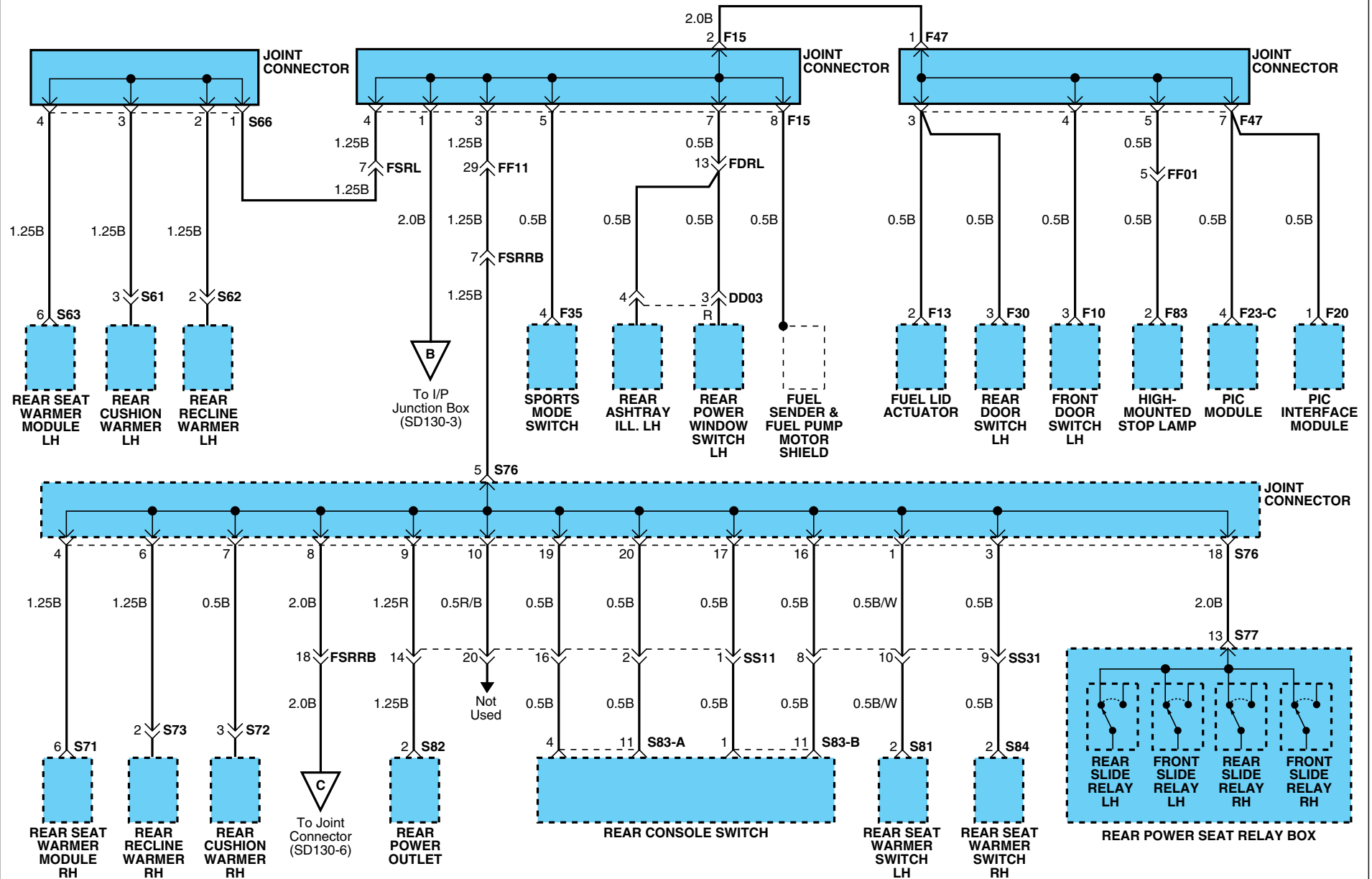

GROUND DISTRIBUTION

GROUND DISTRIBUTION (6)

SD130-6

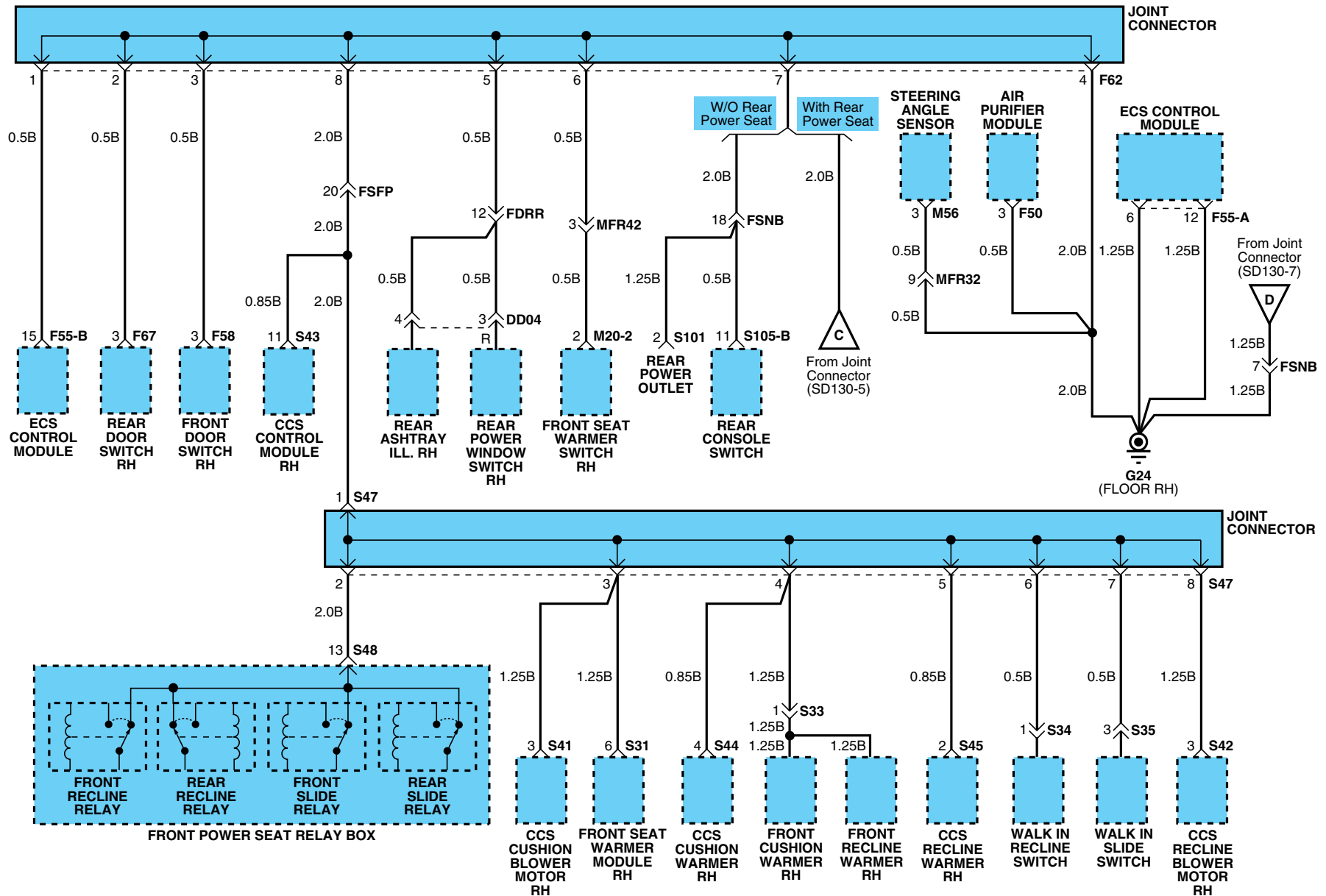

GROUND DISTRIBUTION

GROUND DISTRIBUTION (7)

SD130-7

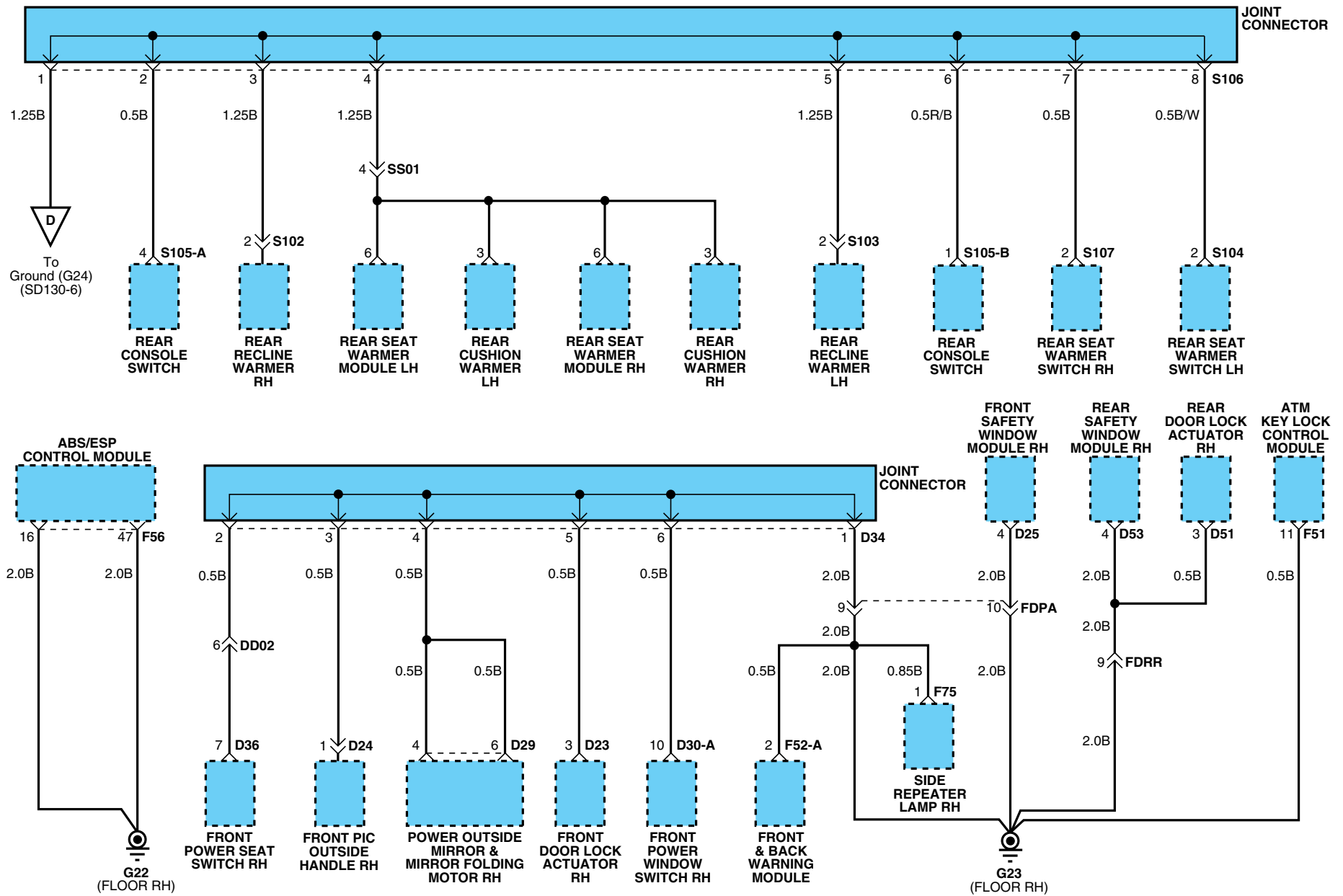

GROUND DISTRIBUTION

GROUND DISTRIBUTION (8)

SD130-8

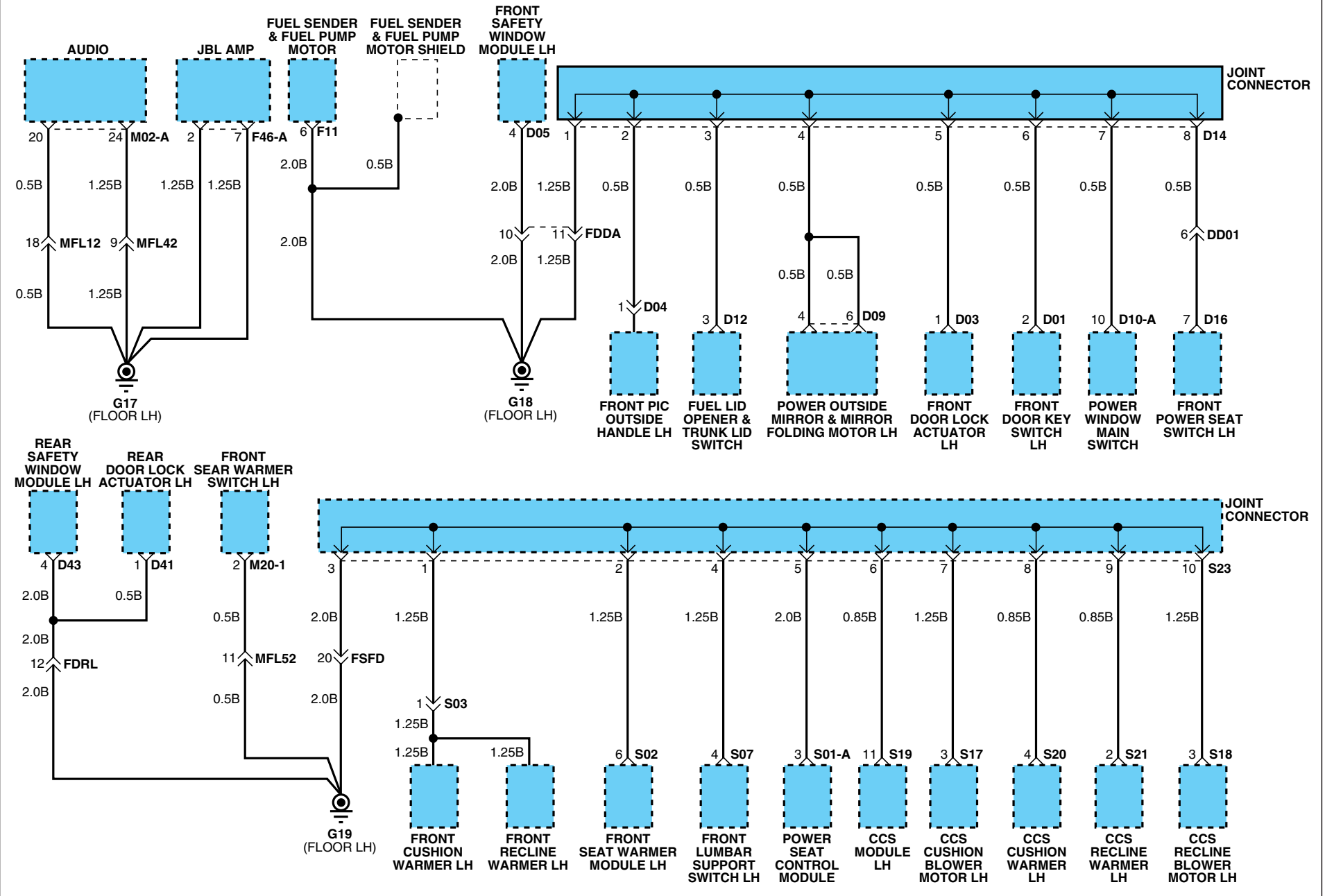

GROUND DISTRIBUTION

GROUND DISTRIBUTION (9)

SD130-9

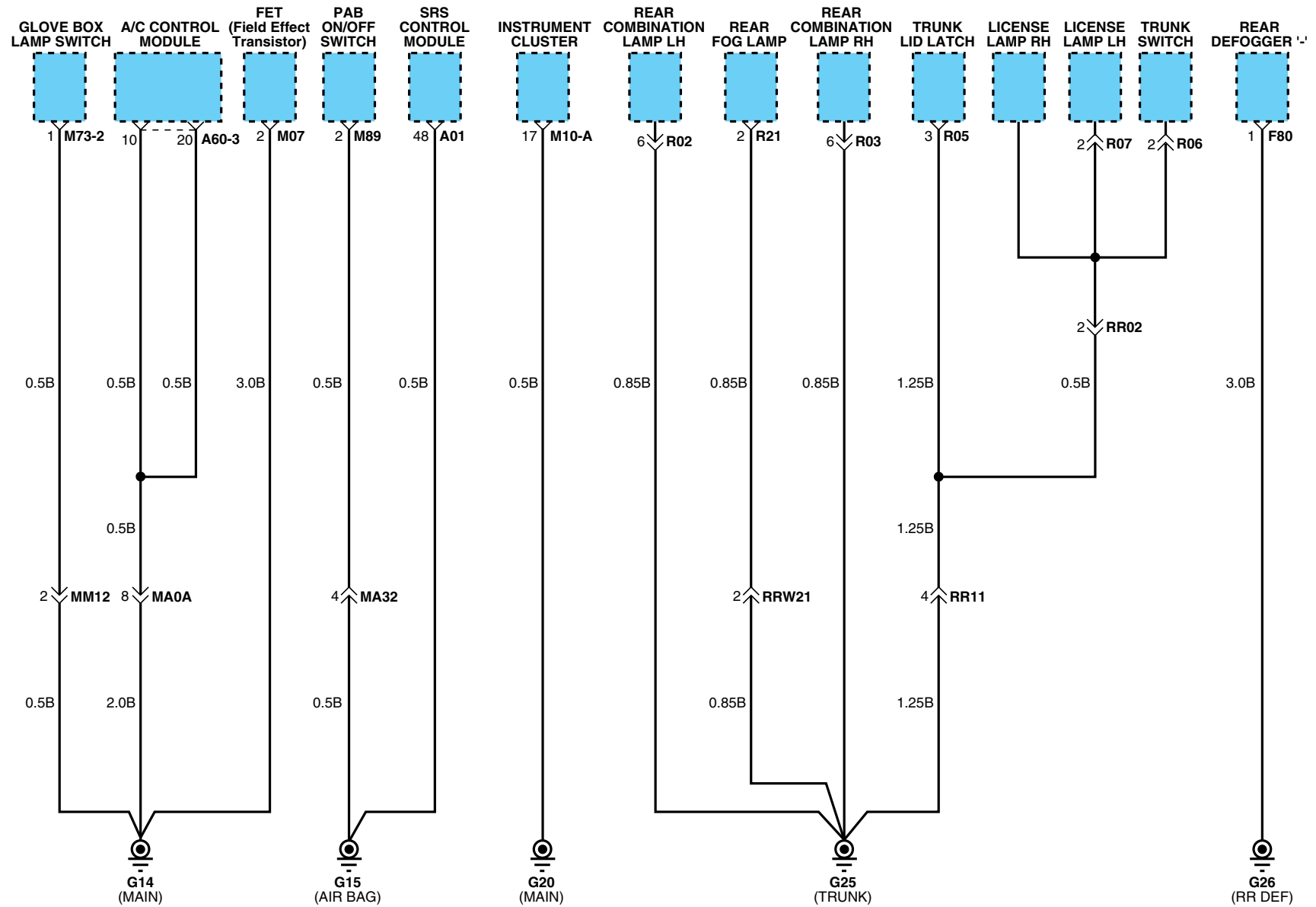

GROUND DISTRIBUTION

GROUND DISTRIBUTION (10)

SD130-10

MEMO

DATA LINK DETAILS (1)

SD200-1

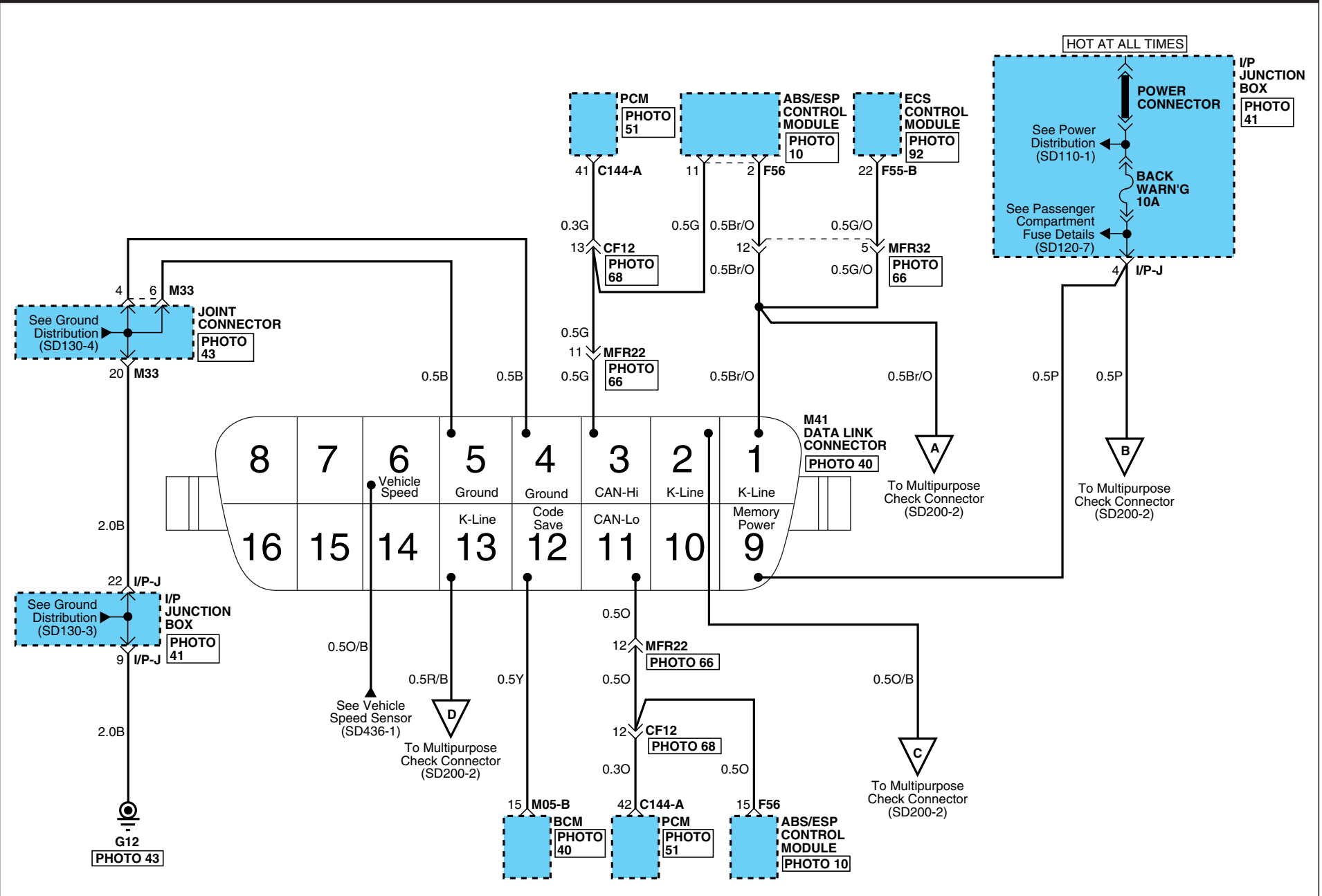

DATA LINK DETAILS

DATA LINK DETAILS (2)

SD200-2

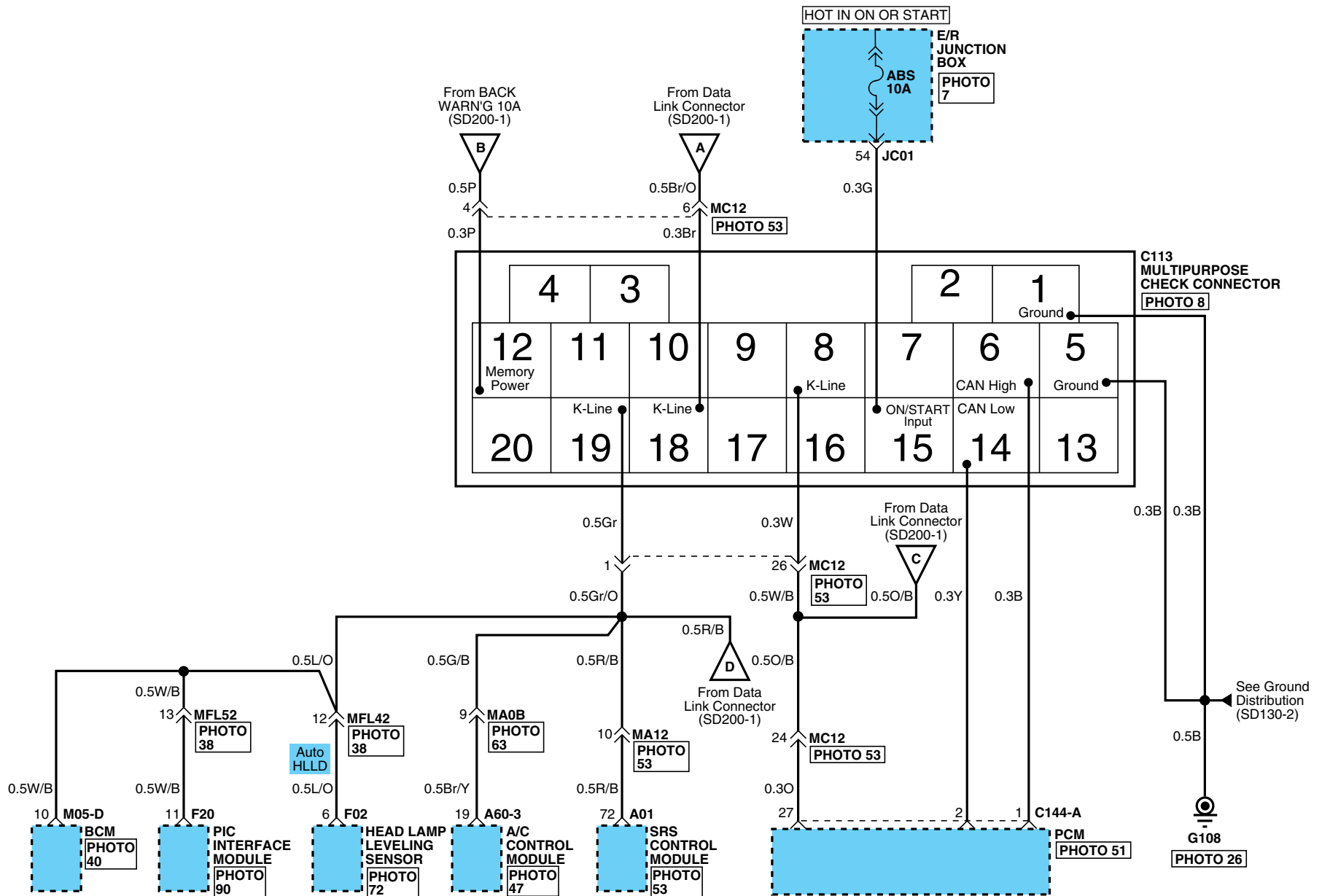

DATA LINK DETAILS

DATA LINK DETAILS (4)

SD200-4

MEMO

COOLING SYSTEM (1)

SD253-1

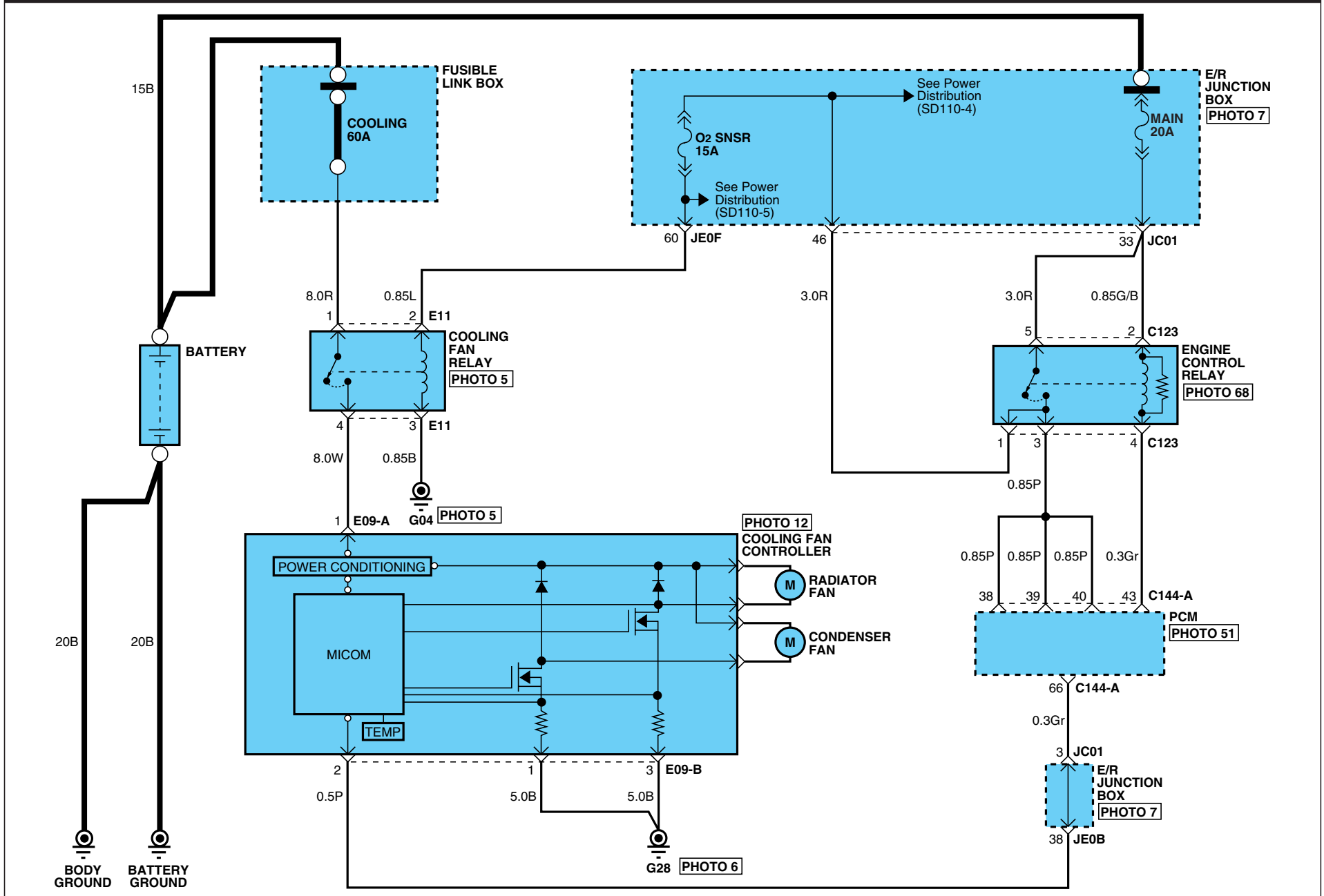

COOLING SYSTEM

COOLING SYSTEM (2)

SD253-2

C123

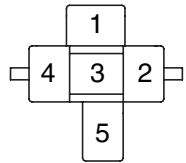

KET_250_05F_B_RLY

E09-A



KET_312IWP_01F_B

C144-A

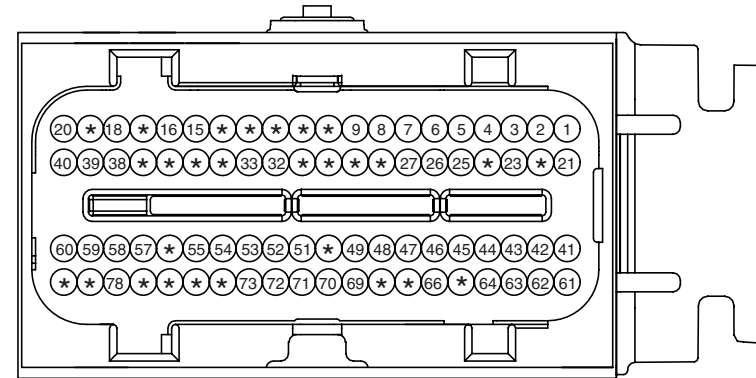

PKD_ECU_80F_GR_3

E09-B

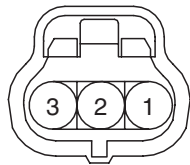

KET_3118_03F_B

E11

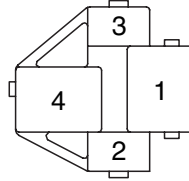

KET_3725_04F_B

MFI CONTROL SYSTEM

MFI CONTROL SYSTEM (G6DA) (3)

SD313-3

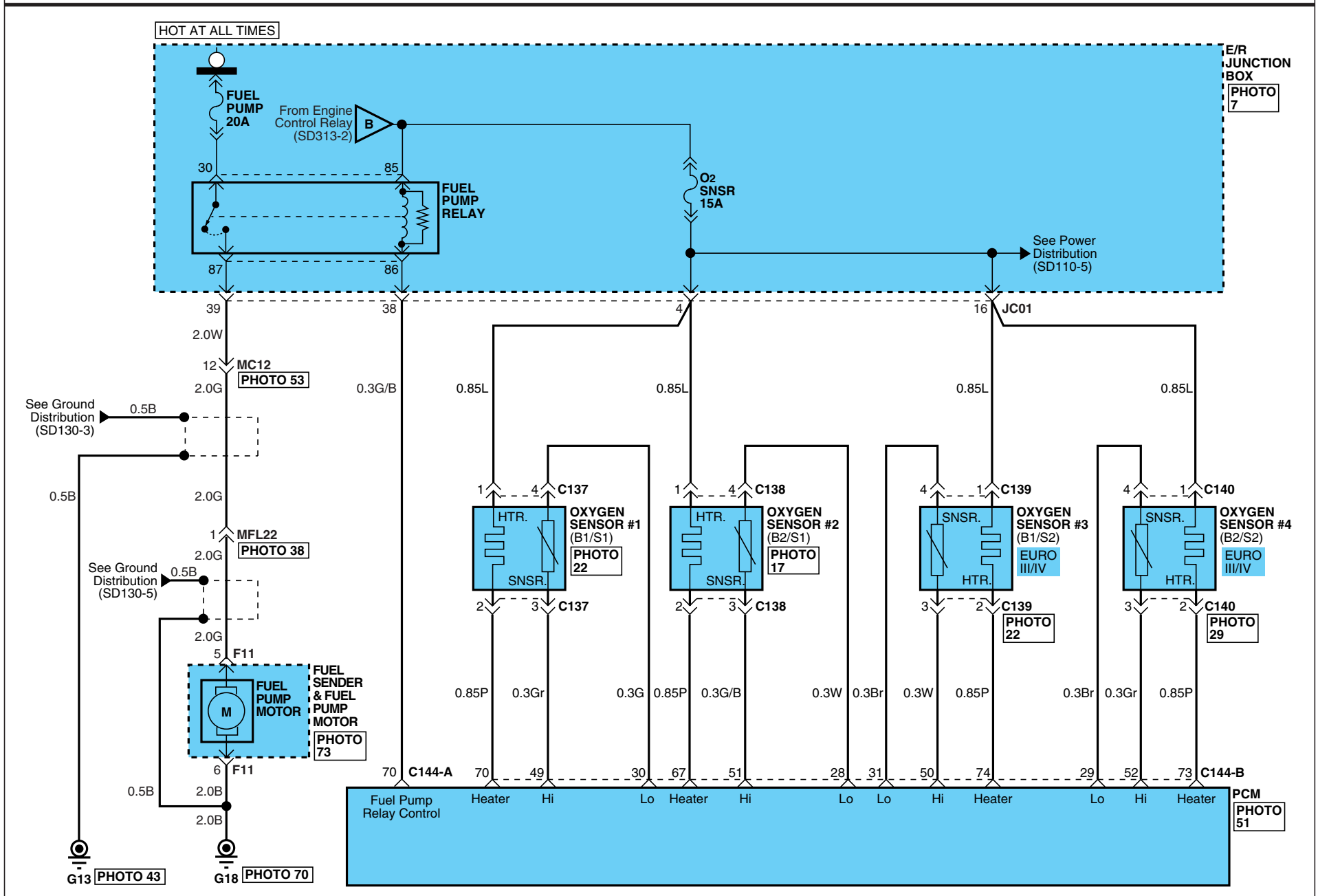

MFI CONTROL SYSTEM

MFI CONTROL SYSTEM (G6DA) (4)

SD313-4

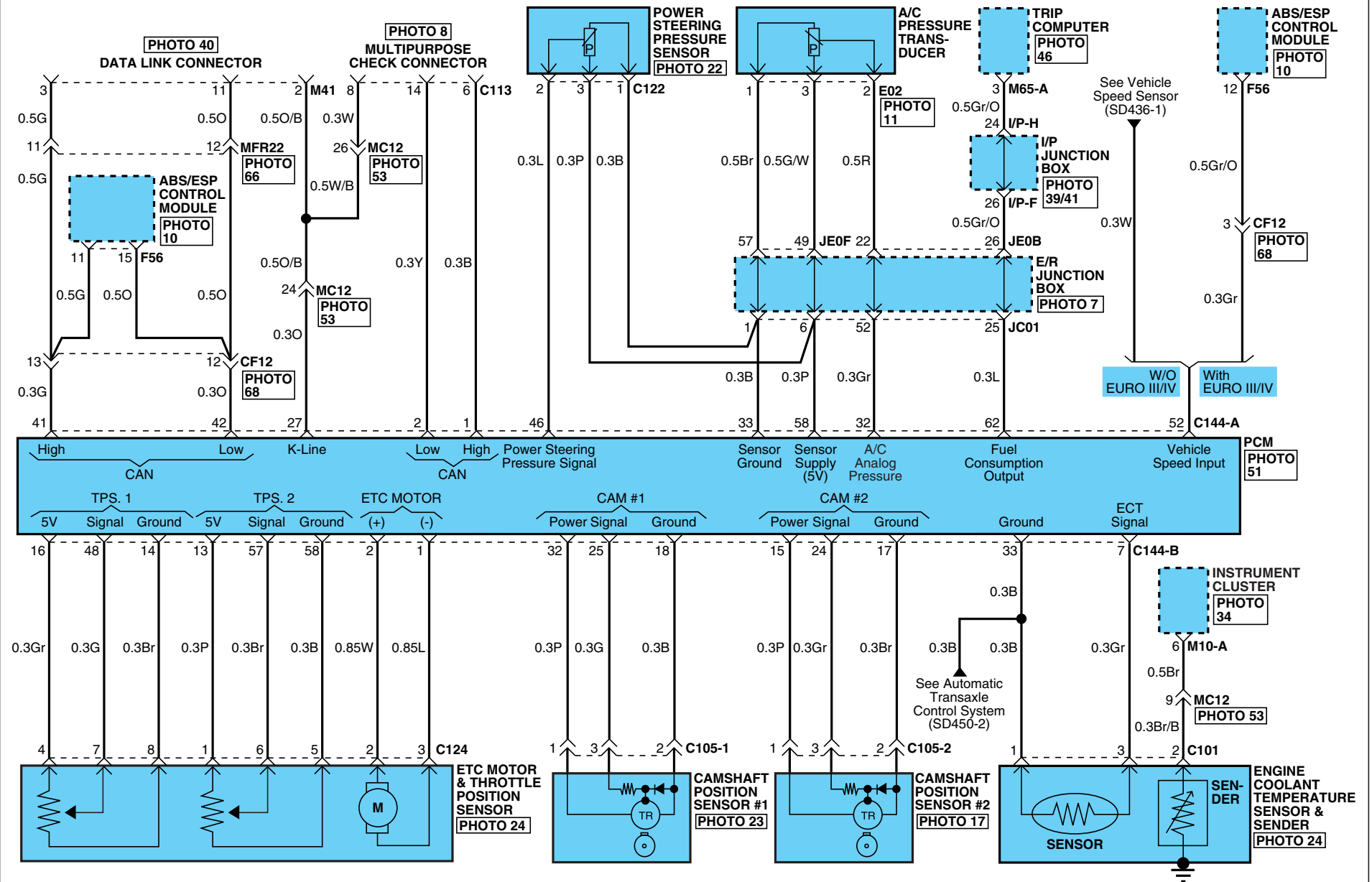

MFI CONTROL SYSTEM

MFI CONTROL SYSTEM (G6DA) (5)

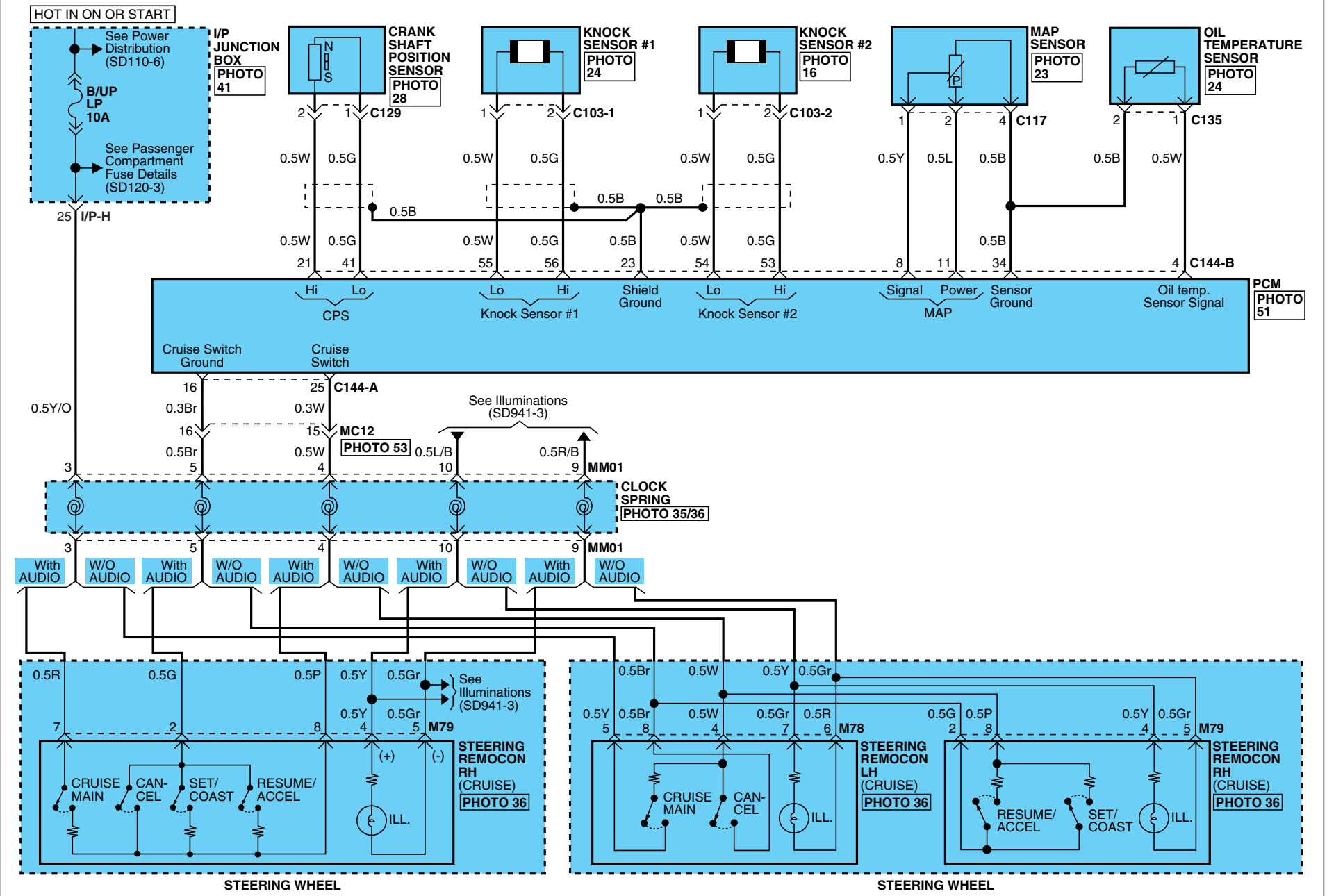

SD313-5



MFI CONTROL SYSTEM

MFI CONTROL SYSTEM (G6DA) (7)

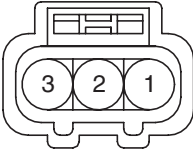
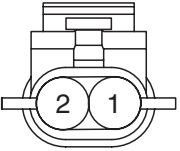
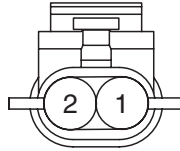
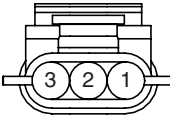
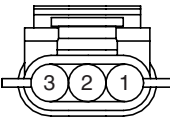
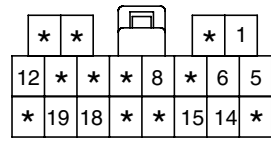
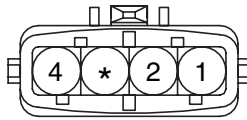
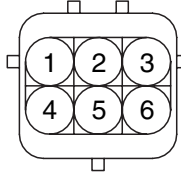
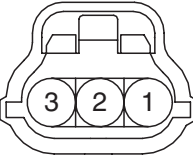
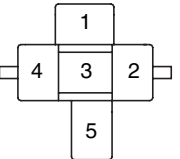
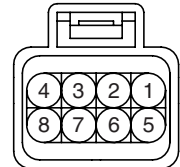
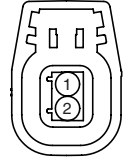
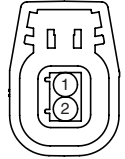
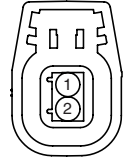
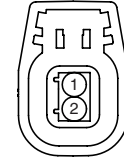
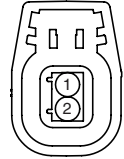
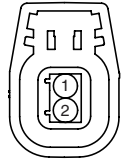
SD313-7

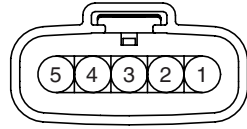
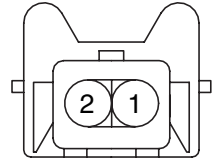
<p>C101</p>  <p>KUM_62Z_03F_B_WTS</p>	<p>C103-1</p>  <p>PKD_MP150_02F_GR</p>	<p>C103-2</p>  <p>PKD_MP150_02F_GR</p>	<p>C105-1</p>  <p>PKD_150WP_03F_B_L</p>
<p>C105-2</p>  <p>PKD_150WP_03F_B_L</p>	<p>C113</p>  <p>KET_DIAGNOSIS_20F_B_B</p>	<p>C117</p>  <p>AMP_JPT_04F_B_BOSCH</p>	<p>C119</p>  <p>AMP_EJWP_06M_B</p>
<p>C122</p>  <p>YAZ_040WP_03F_B</p>	<p>C123</p>  <p>KET_250_05F_B_RLY</p>	<p>C124</p>  <p>PKD_GT150_08F_B</p>	<p>C128-1</p>  <p>PKD_GT150_02F_B</p>
<p>C128-2</p>  <p>PKD_GT150_02F_B</p>	<p>C128-3</p>  <p>PKD_GT150_02F_B</p>	<p>C128-4</p>  <p>PKD_GT150_02F_B</p>	<p>C128-5</p>  <p>PKD_GT150_02F_B</p>
<p>C128-6</p>  <p>PKD_GT150_02F_B</p>	<p>C129</p>  <p>PKD_GT150WP_02F_B</p>	<p>C130</p>  <p>PKD_GT150_05F_B</p>	<p>C135</p>  <p>AMP_JPT_02F_B_CLIP</p>

MFI CONTROL SYSTEM

MFI CONTROL SYSTEM (G6DA) (8)

SD313-8

C137

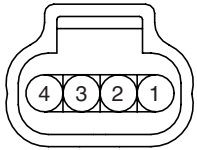

PKD_GT150_04F_GR

C138

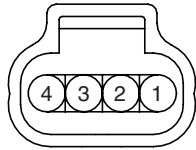

PKD_GT150_04F_B

C139

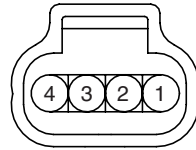

PKD_GT150_04F_B

C140

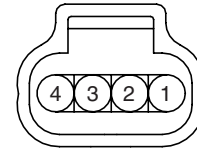

PKD_GT150_04F_GR

C144-A

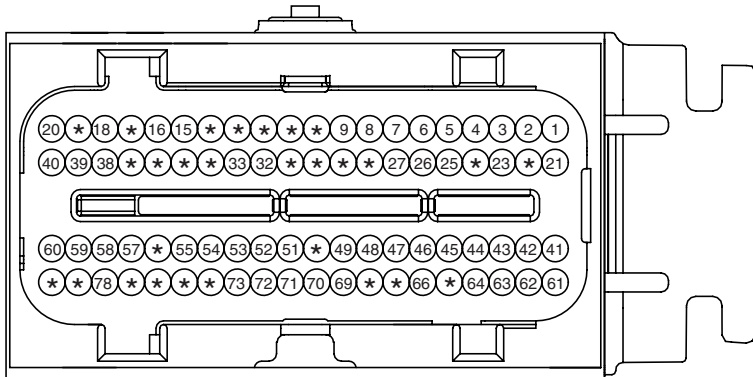

PKD_ECU_80F_GR_3

C144-B

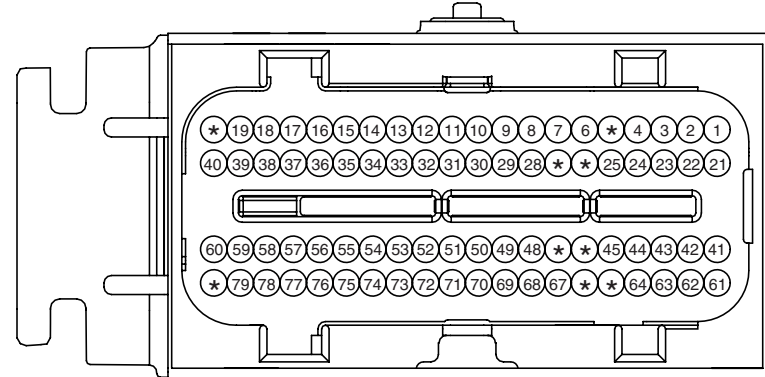

PKD_ECU_80F_B_2

C146

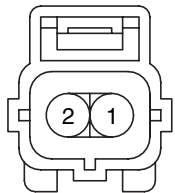

AMP_EJWP_02F_B

C148

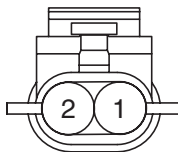

PKD_150WP_02F_B

C149

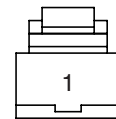

KET_250_01F_B_1

C151-1



KET_090IWP_02F_GR_VER

C151-2



KET_090IWP_02F_GR_VER

C151-3



KET_090IWP_02F_GR_VER

C151-4



KET_090IWP_02F_GR_VER

C151-5





KET_090IWP_02F_GR_VER

MFI CONTROL SYSTEM

MFI CONTROL SYSTEM (G6DA) (9)

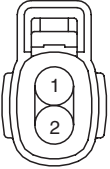
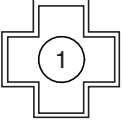
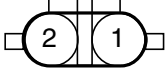
SD313-9

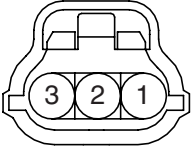
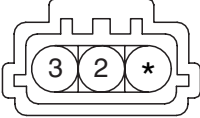
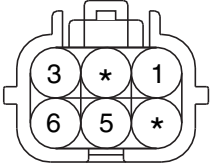
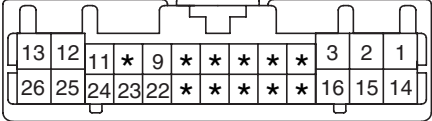
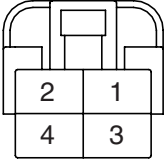
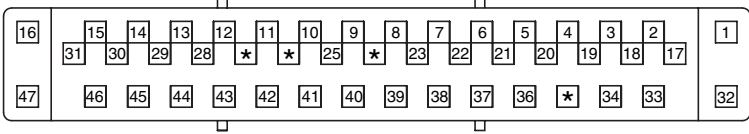
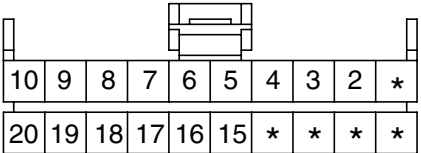
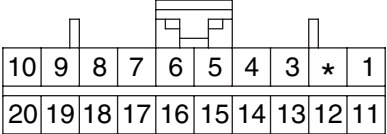
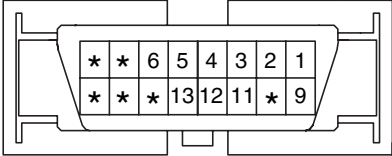
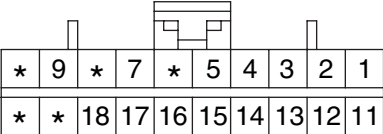
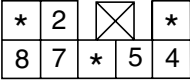
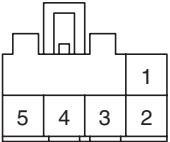
<p>C151-6</p>  <p>KET_090IWP_02F_GR_VER</p>	<p>C155</p>  <p>CR01F054</p>	<p>C156-1</p>  <p>CR02F134</p>	<p>C156-2</p>  <p>CR02F134</p>
<p>E02</p>  <p>YAZ_040WP_03F_B</p>	<p>E52</p>  <p>SUM_ALTWP_03F_GR</p>	<p>F11</p>  <p>KET_SWP_06F_B</p>	<p>F20</p>  <p>KET_0407_26F_W</p>
<p>F36</p>  <p>KET_250DL_04F_W</p>	<p>F56</p>  <p>AMP_ESP_47F_L_UNIT</p>		<p>M10-A</p>  <p>AMP_040M1_20F_B</p>
<p>M10-B</p>  <p>AMP_040M2_20F_B</p>	<p>M41</p>  <p>MLX_OBDII_16F_B_SIN</p>	<p>M65-A</p>  <p>AMP_040M2_20F_B</p>	<p>M79</p>  <p>KET_SDL_8F</p>
<p>M85</p>  <p>KUM_CDR_05F_W</p>	<p>BLANK</p>	<p>BLANK</p>	<p>BLANK</p>

MFI CONTROL SYSTEM

MFI CONTROL SYSTEM (G6DA) (10)

SD313-10

MEMO

STARTING SYSTEM

STARTING SYSTEM (2)

SD360-2

C109



KET_SSD_10F_B_A

E53

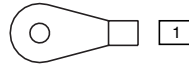

CHT_STMTR_8T_N

E54

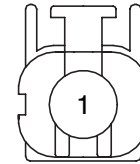

KET_250WP_01F_B

M05-D

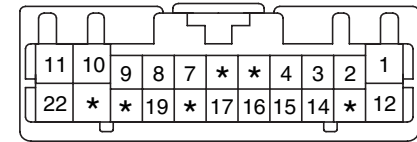

KET_0407_22F_W

M28

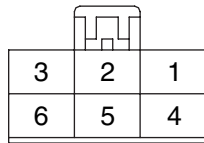

KUM_DSD_06F_W

BLANK

BLANK

BLANK

CHARGING SYSTEM (1)

SD373-1

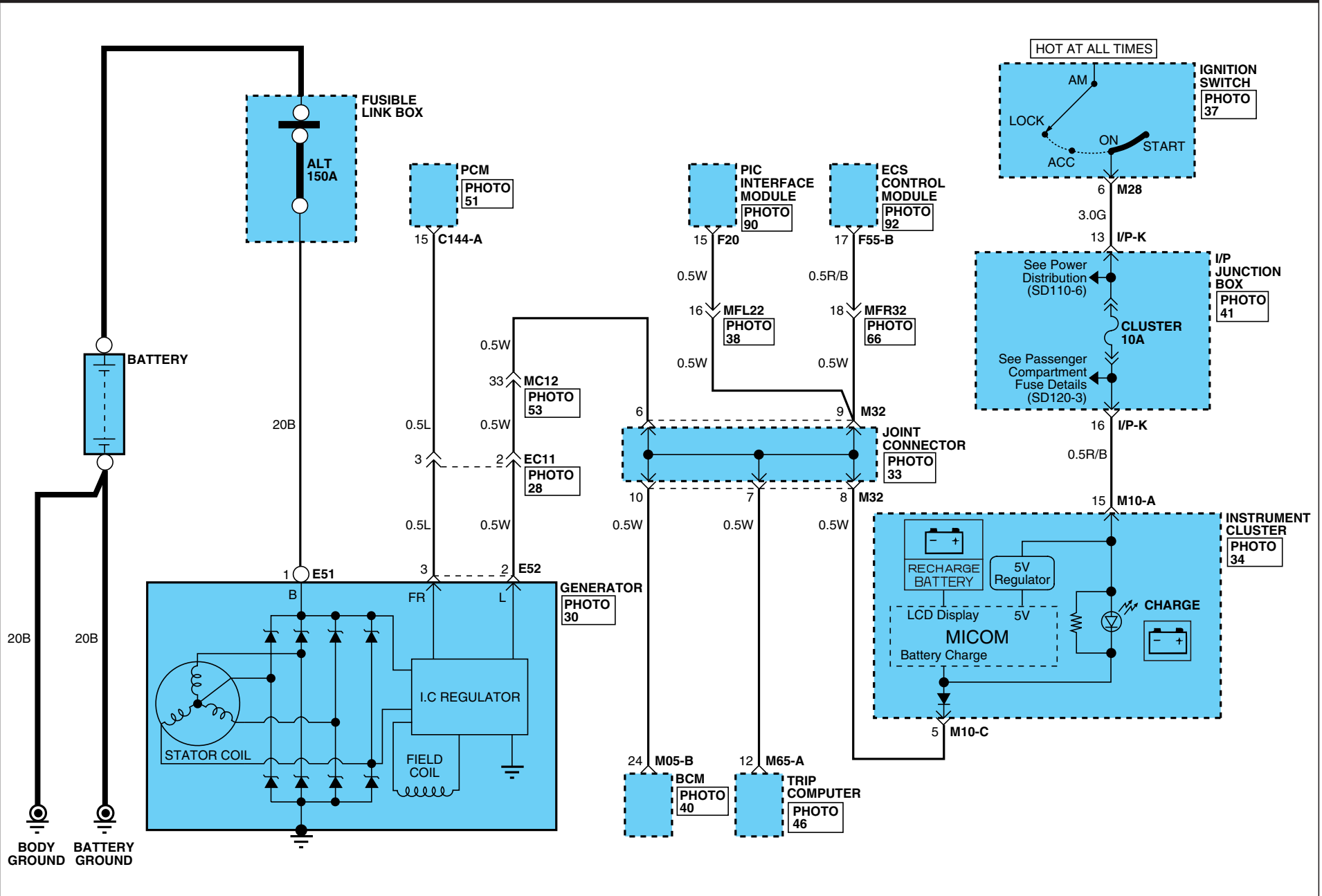

CHARGING SYSTEM

CHARGING SYSTEM (2)

SD373-2

C144-A

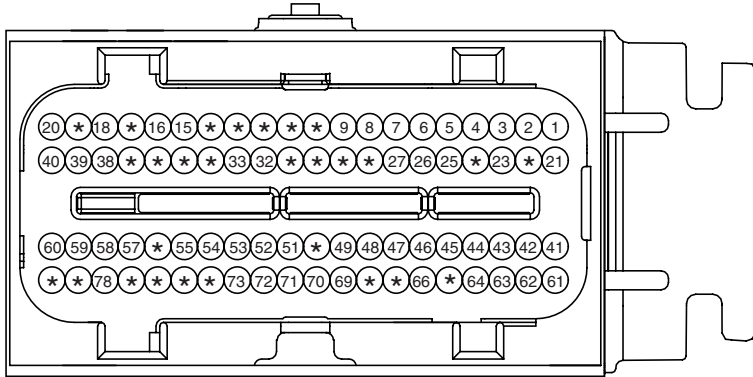

PKD_ECU_80F_GR_3

E51

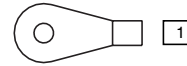

CHT_ALT_RING_N

E52

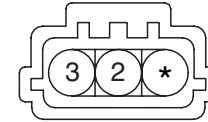

SUM_ALTW_P_03F_GR

F20

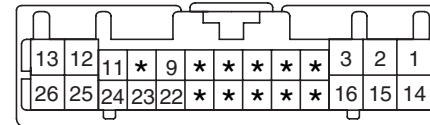

KET_0407_26F_W

F55-B

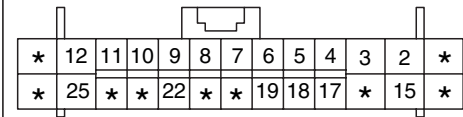

AMP_0407_26F_W_HD

M05-B

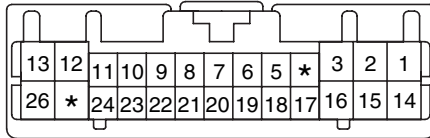

KET_0407_26F_W

M10-A

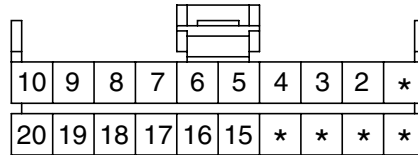

AMP_040M1_20F_B

M10-C

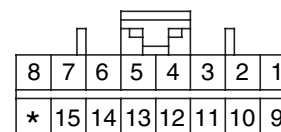

AMP_040M2_16F_B

M28

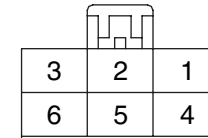

KUM_DSD_06F_W

M65-A

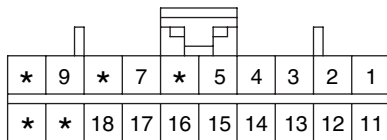

AMP_040M2_20F_B

BLANK

BLANK

BLANK

VEHICLE SPEED SENSOR (1)

SD436-1

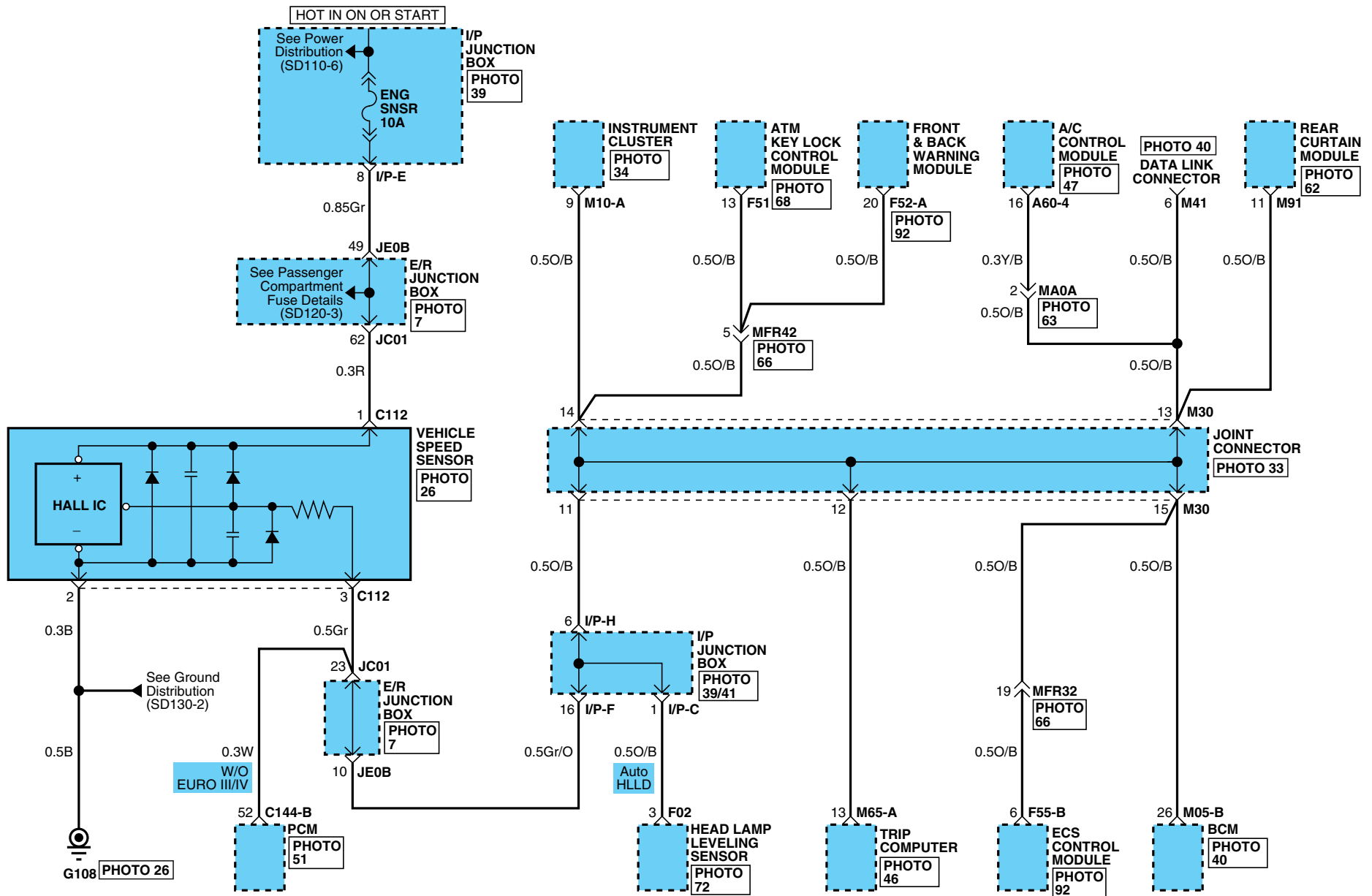

VEHICLE SPEED SENSOR

VEHICLE SPEED SENSOR (2)

SD436-2

A60-4

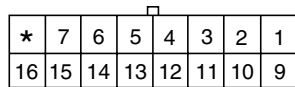

CR16F024

C112

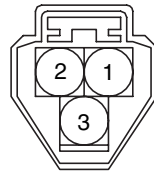

KUM_NMWP_03F_B

C144-B

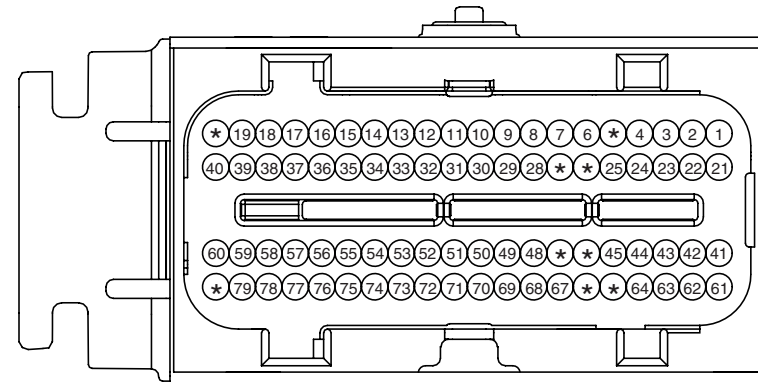

PKD_ECU_80F_B_2

F02

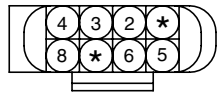

FEP_DEV_08F_B

F51

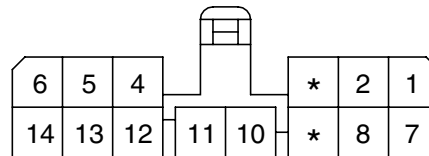

AMP_070_14F_W

F52-A

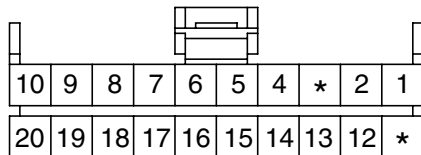

AMP_040M1_20F_B

F55-B

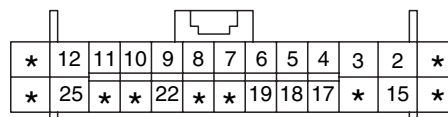

AMP_0407_26F_W_HD

M05-B

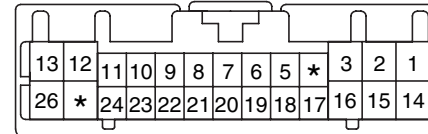

KET_0407_26F_W

M10-A

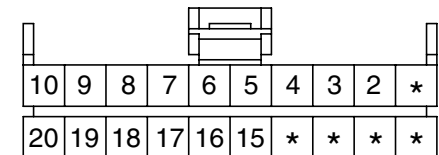

AMP_040M1_20F_B

M41

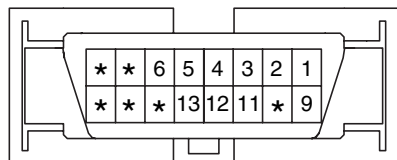

MLX_OBDII_16F_B_SIN

M65-A

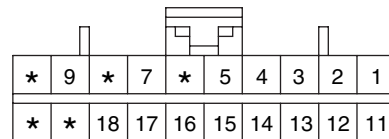

AMP_040M2_20F_B

M91

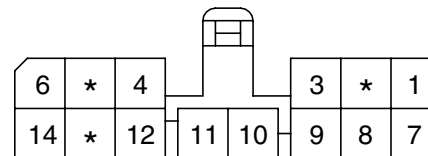

AMP_070_14F_W

BLANK

AUTOMATIC TRANSAXLE CONTROL SYSTEM

AUTOMATIC TRANSAXLE CONTROL SYSTEM (G6DA) (2)

SD450-2

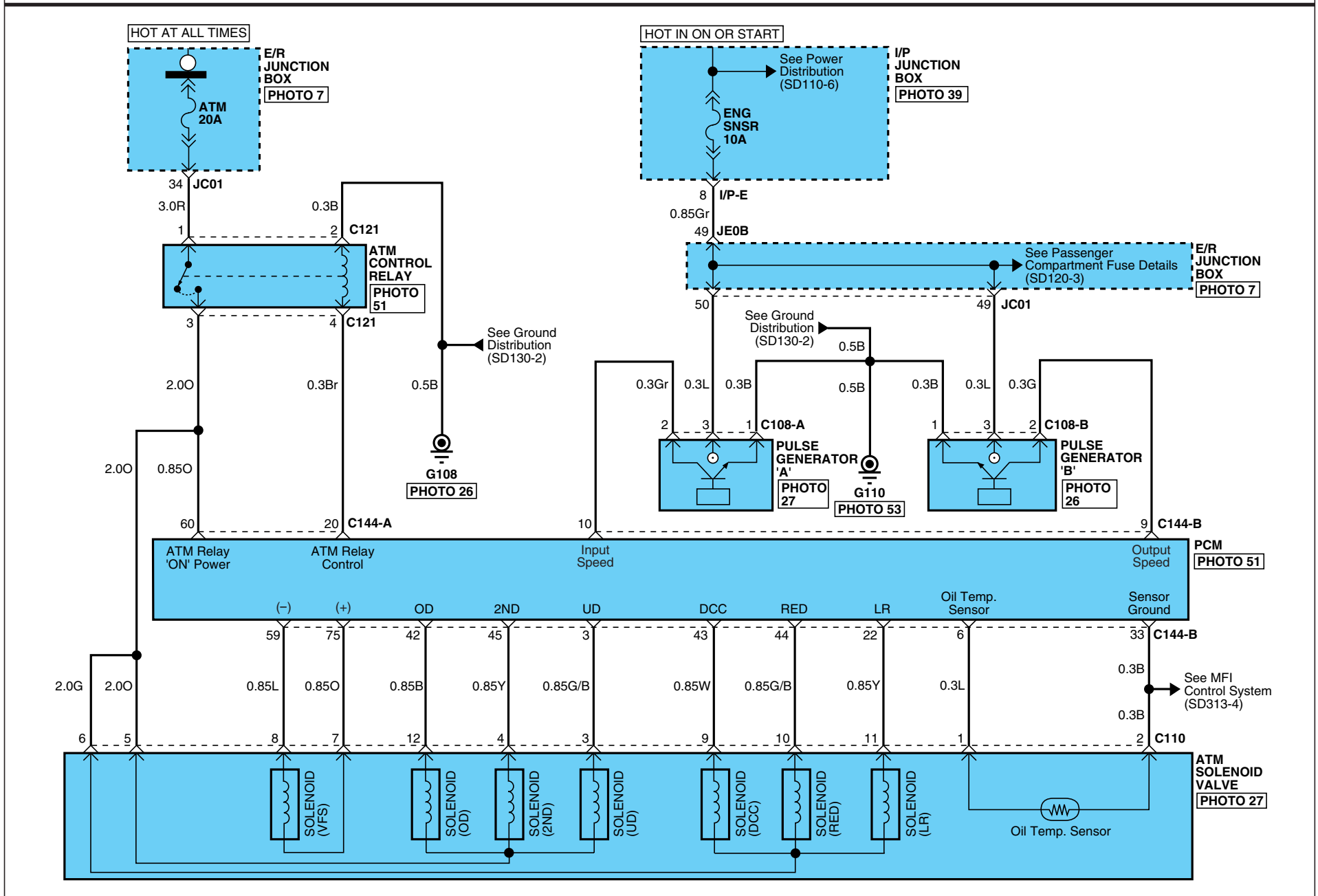

AUTOMATIC TRANSAXLE CONTROL SYSTEM

AUTOMATIC TRANSAXLE CONTROL SYSTEM (G6DA) (3)

SD450-3

C108-A

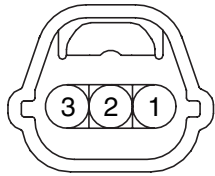

KET_SSD_03F_B_A

C108-B

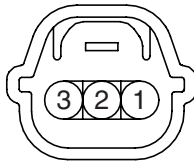

KET_SSD_03F_Gr_B

C109



KET_SSD_10F_B_A

C110



KET_SSD_12F_B

C144-A

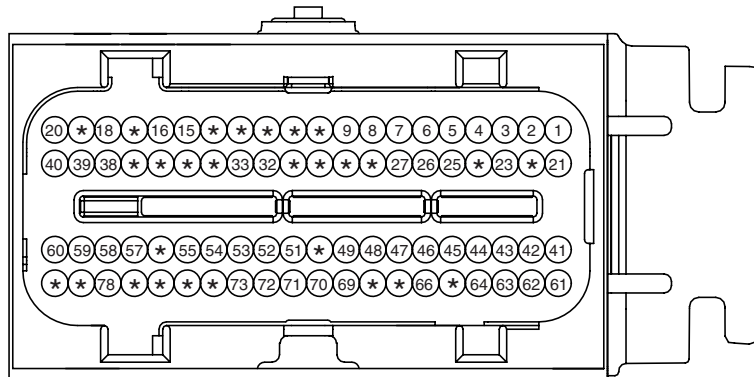

PKD_ECU_80F_GR_3

C144-B

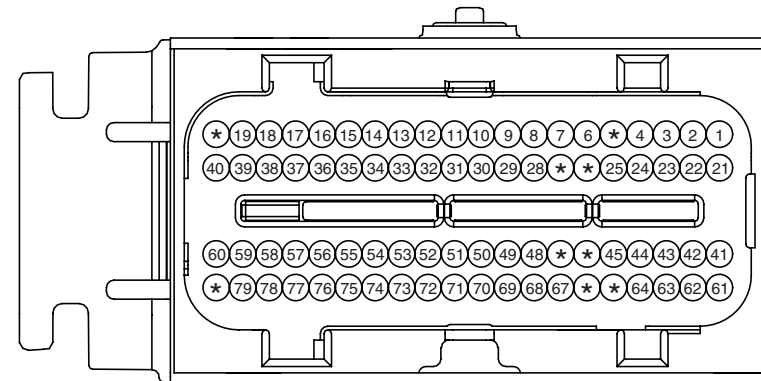

PKD_ECU_80F_B_2

C121

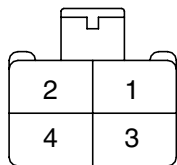

KUM_DSD_04F_W

F35

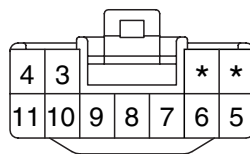

KET_090II_11F_W

M10-B

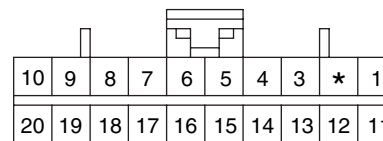

AMP_040M2_20F_B

BLANK

AUTOMATIC TRANSAXLE CONTROL SYSTEM

AUTOMATIC TRANSAXLE CONTROL SYSTEM (G6DA) (4)

SD450-4

MEMO

ADJUSTABLE PEDAL & SHIFT LOCK CONTROL SYSTEM (1)

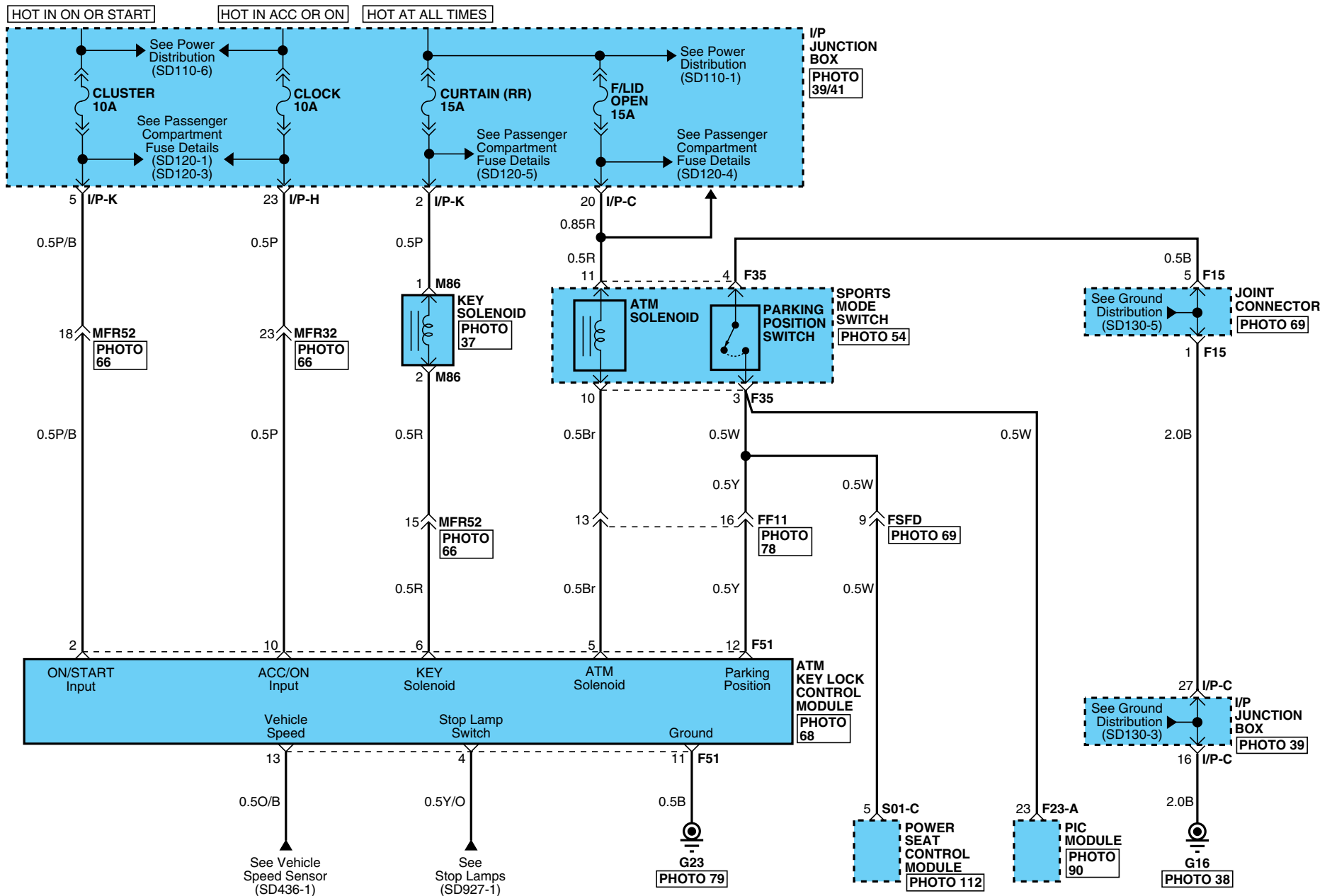

SD452-1



ADJUSTABLE PEDAL & SHIFT LOCK CONTROL SYSTEM

ADJUSTABLE PEDAL & SHIFT LOCK CONTROL SYSTEM (3)

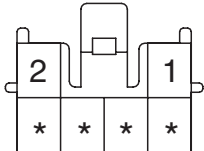
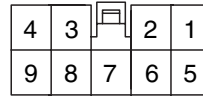
SD452-3

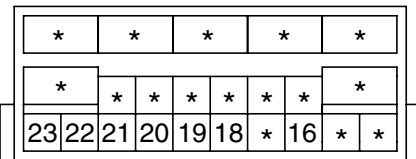
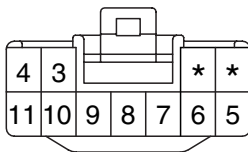
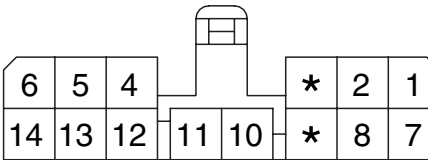
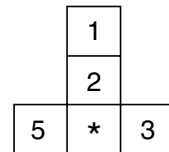
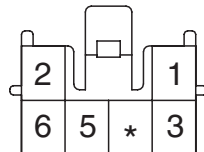
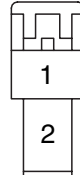
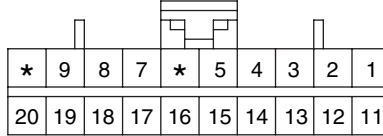
<p>C104</p>  <p>KET_070_06F_W</p>	<p>C106</p>  <p>KET_PA_09F_W</p>	<p>C109</p>  <p>KET_SSD_10F_B_A</p>	<p>F23-A</p>  <p>SIE_PIC_23F_GR</p>
<p>F35</p>  <p>KET_090II_11F_W</p>	<p>F51</p>  <p>AMP_070_14F_W</p>	<p>M68</p>  <p>CR05F011</p>	<p>M80</p>  <p>KET_070_06F_Y</p>
<p>M86</p>  <p>KUM_DSD_02F_W</p>	<p>S01-C</p>  <p>AMP_040MII_20F</p>	<p>BLANK</p>	<p>BLANK</p>

ADJUSTABLE PEDAL & SHIFT LOCK CONTROL SYSTEM

ADJUSTABLE PEDAL & SHIFT LOCK CONTROL SYSTEM (4)

SD452-4

MEMO

ECS (ELECTRONIC CONTROL SUSPENSION) SYSTEM

ECS (ELECTRONIC CONTROL SUSPENSION) SYSTEM (2)

SD558-2

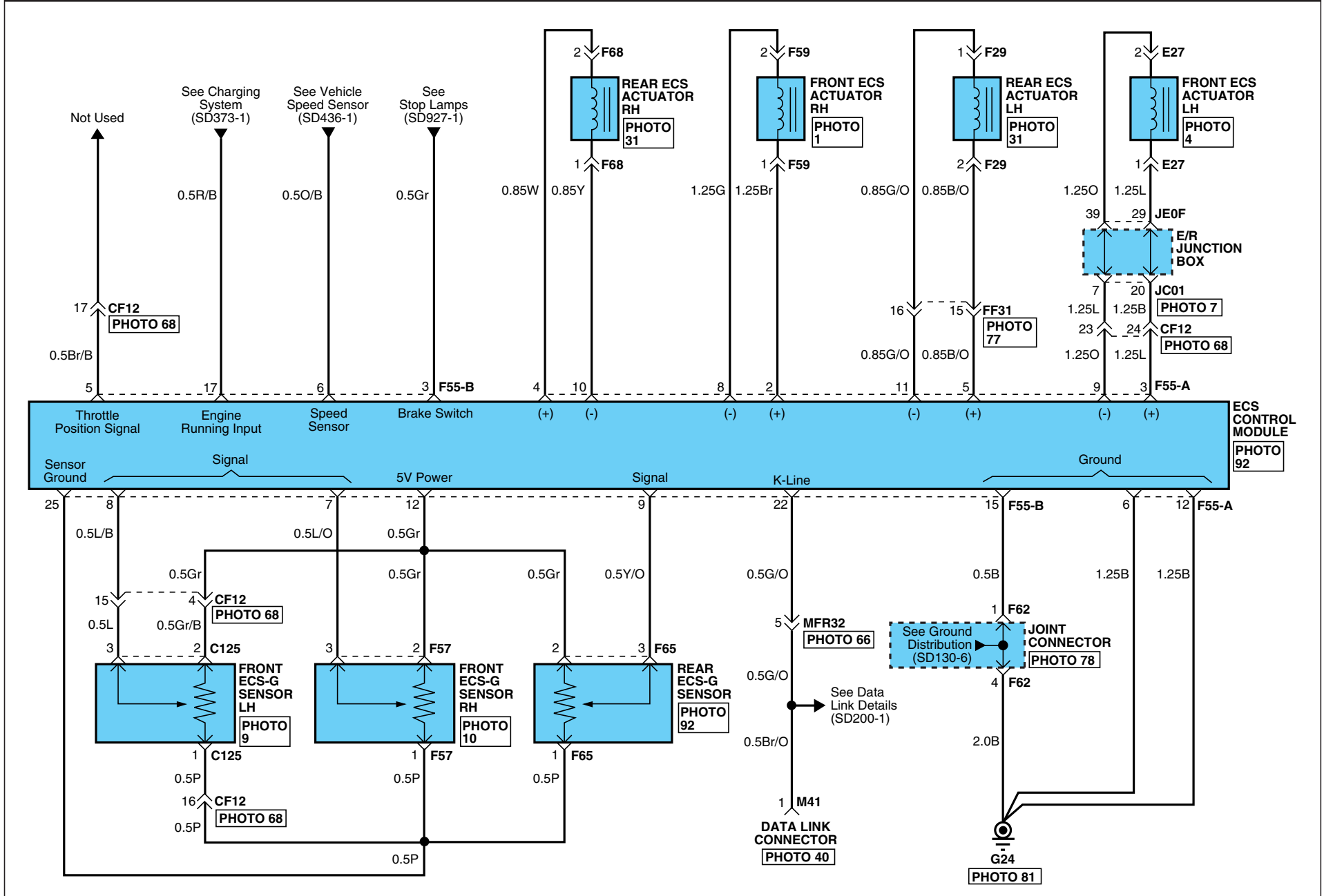

ECS (ELECTRONIC CONTROL SUSPENSION) SYSTEM

ECS (ELECTRONIC CONTROL SUSPENSION) SYSTEM (3)

SD558-3

C125

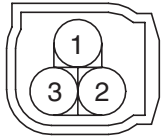

AMP_MQSWP_03F_GR_2

E27

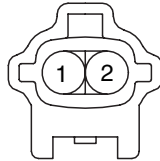

KET_090IWP_02M_GR

E40

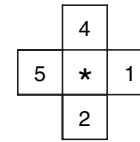

CR05F019

F29

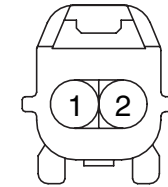

KET_SSD_02M_B

F55-A

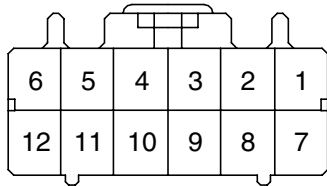

AMP_0407_12F_W_070

F55-B

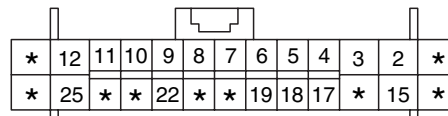

AMP_0407_26F_W_HD

F56

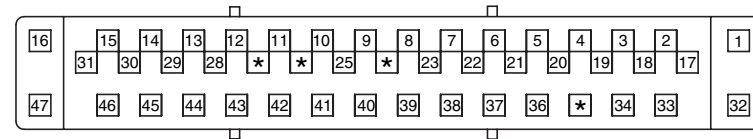

AMP_ESP_47F_L_UNIT

F57

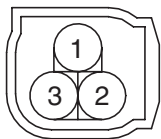

AMP_MQSWP_03F_GR_2

F59

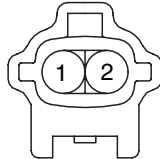

KET_090IWP_02M_GR

F65

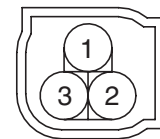

AMP_MQSWP_03F_GR_2

F68

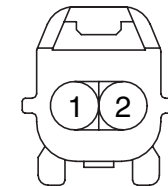

KET_SSD_02M_B

M10-A

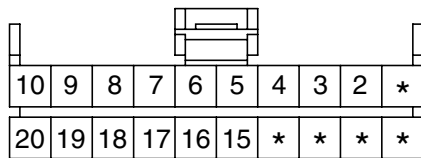

AMP_040M1_20F_B

M12

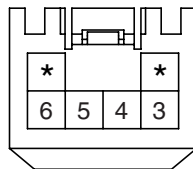

AMP_090III_06F_W_2

M41

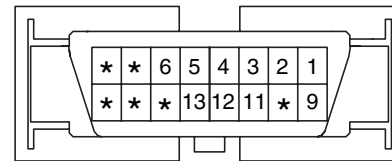

MLX_OBDII_16F_B_SIN

M56

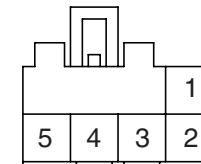

KUM_CDR_05F_W

ECS (ELECTRONIC CONTROL SUSPENSION) SYSTEM

ECS (ELECTRONIC CONTROL SUSPENSION) SYSTEM (4)

SD588-4

MEMO

STEERING TILT & TELESCOPIC SYSTEM (1)

SD564-1

With IMS

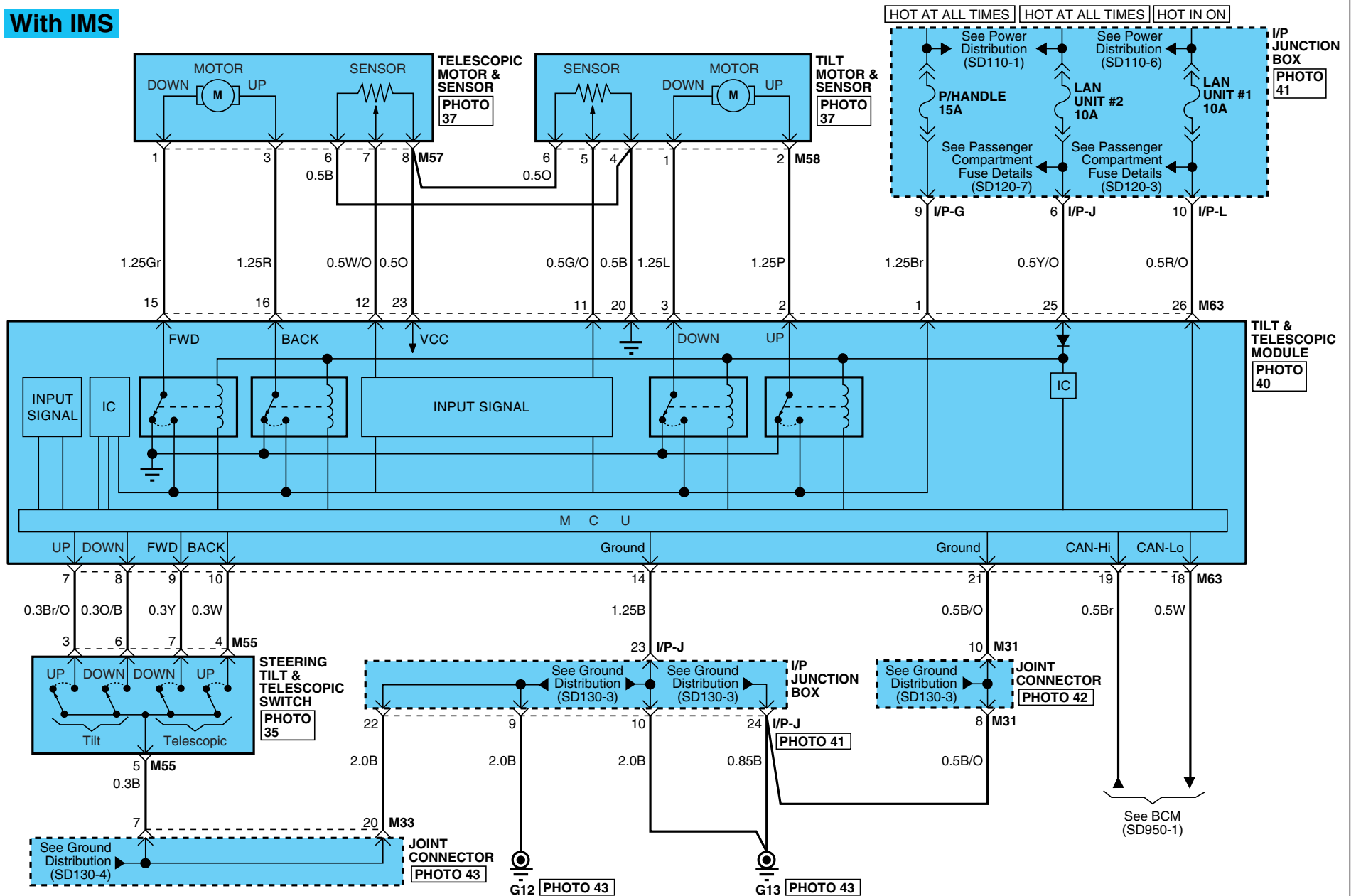

STEERING TILT & TELESCOPIC SYSTEM

STEERING TILT & TELESCOPIC SYSTEM (2)

SD564-2

M55

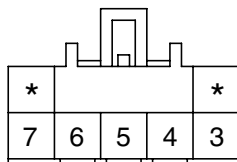

KUM_CDR_07F_W

M57

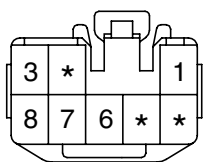

KET_090II_08F_B

M58

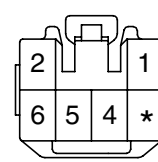

KET_090II_06F_B

M63

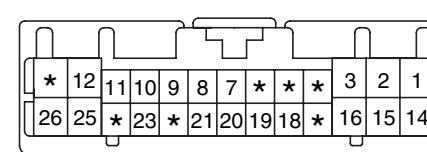

KET_0407_26F_W

AIR BAG SYSTEM (SRS) (1)

SD569-1

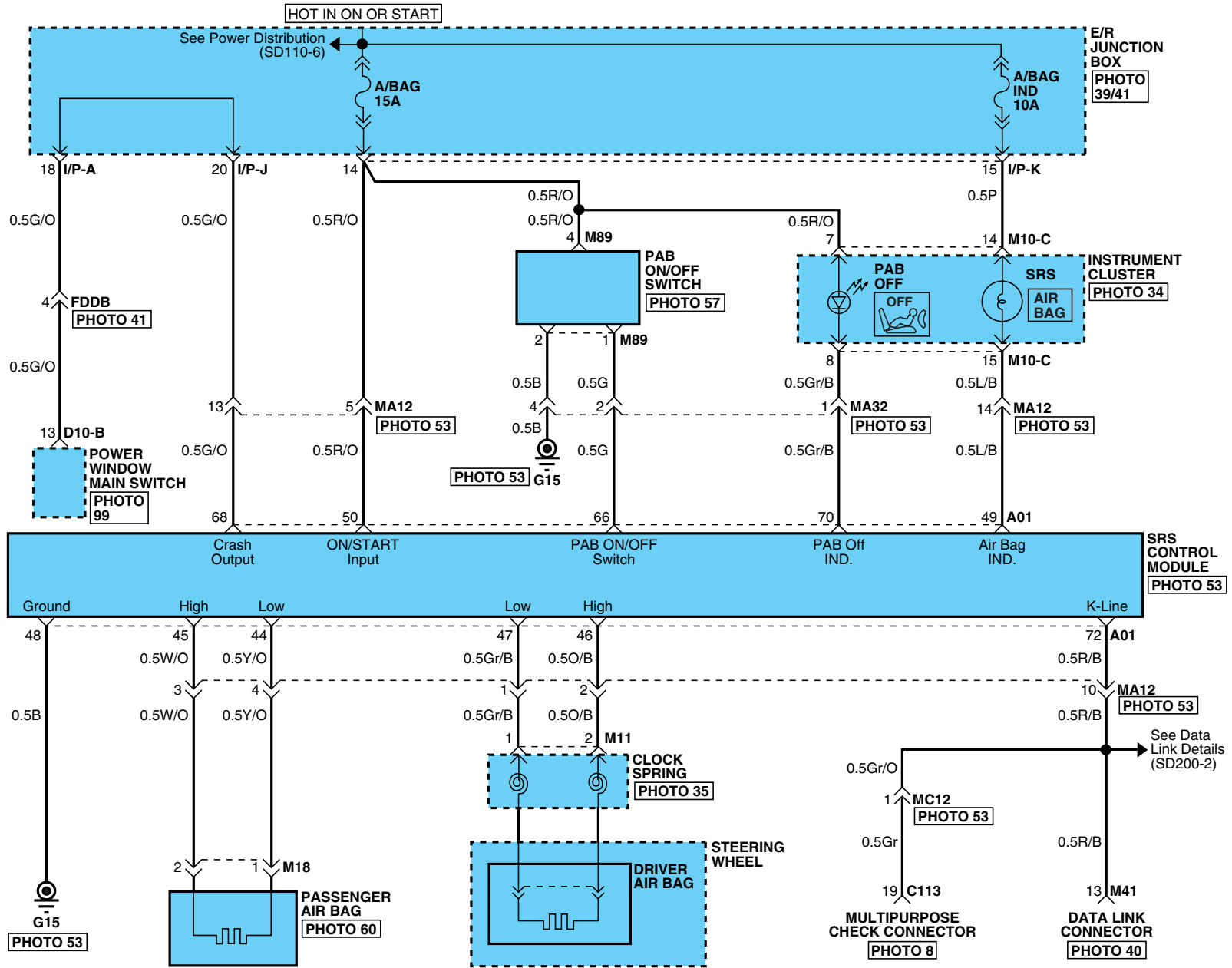

AIR BAG SYSTEM (SRS)

AIR BAG SYSTEM (SRS) (2)

SD569-2

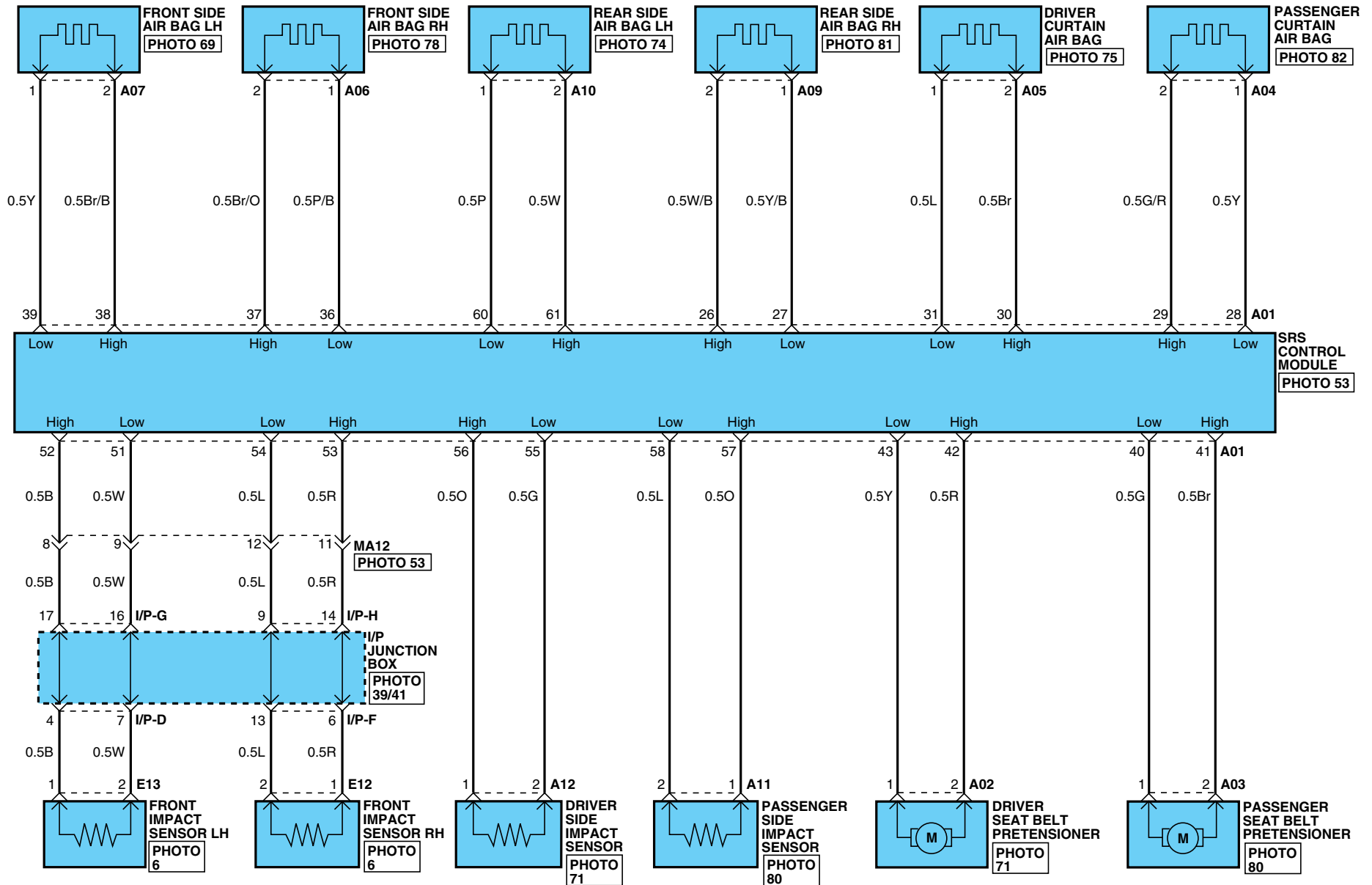

AIR BAG SYSTEM (SRS)

AIR BAG SYSTEM (SRS) (4)

SD569-4

M89

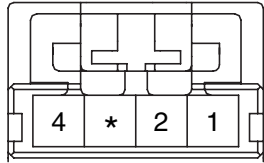

AMP_MQS_04F_Y_040

BLANK

BLANK

BLANK

ANTI-LOCK BRAKE SYSTEM/ TRACTION CONTROL SYSTEM (1)

SD587-1

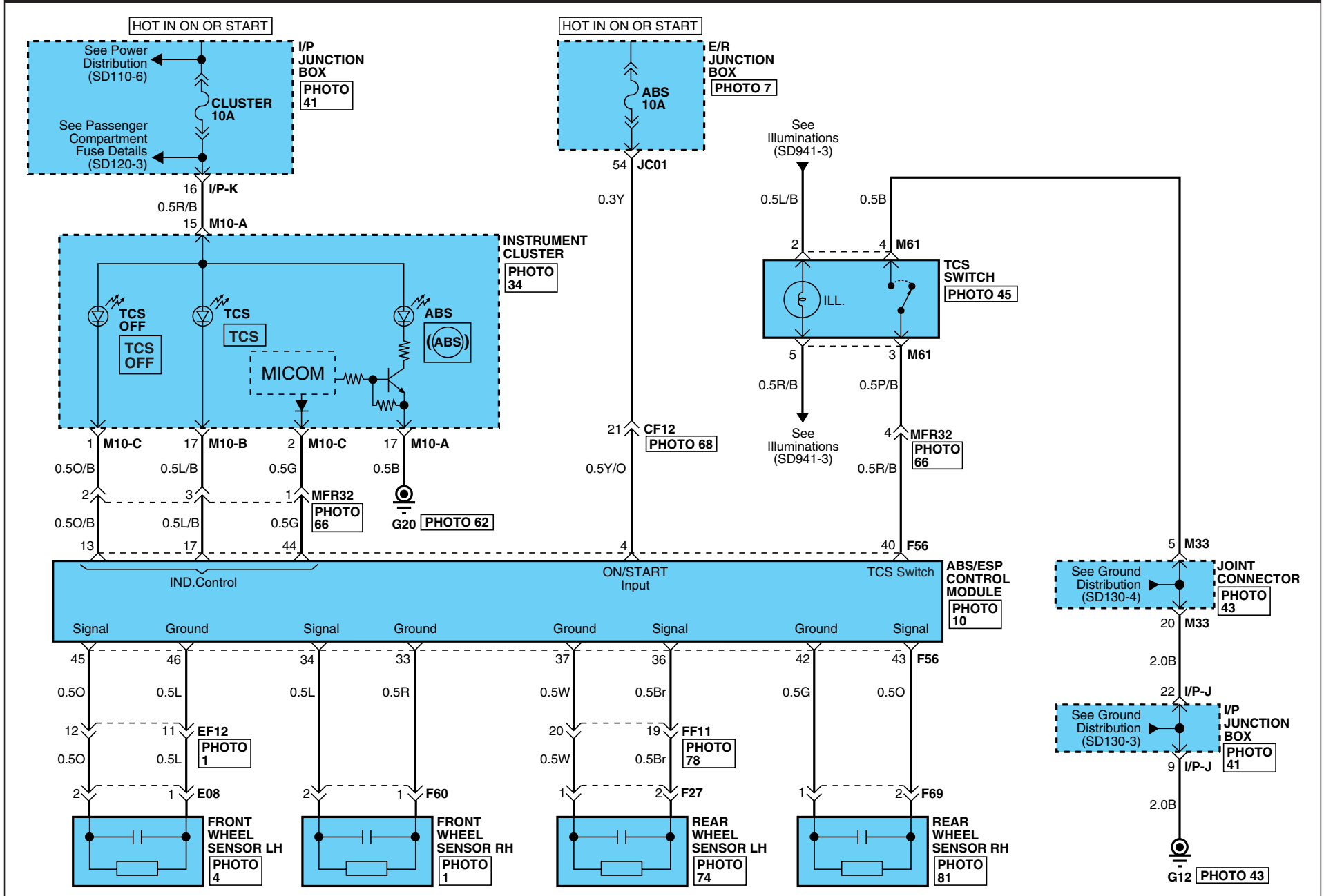

ANTI-LOCK BRAKE SYSTEM/ TRACTION CONTROL SYSTEM

ANTI-LOCK BRAKE SYSTEM/ TRACTION CONTROL SYSTEM (2)

SD587-2

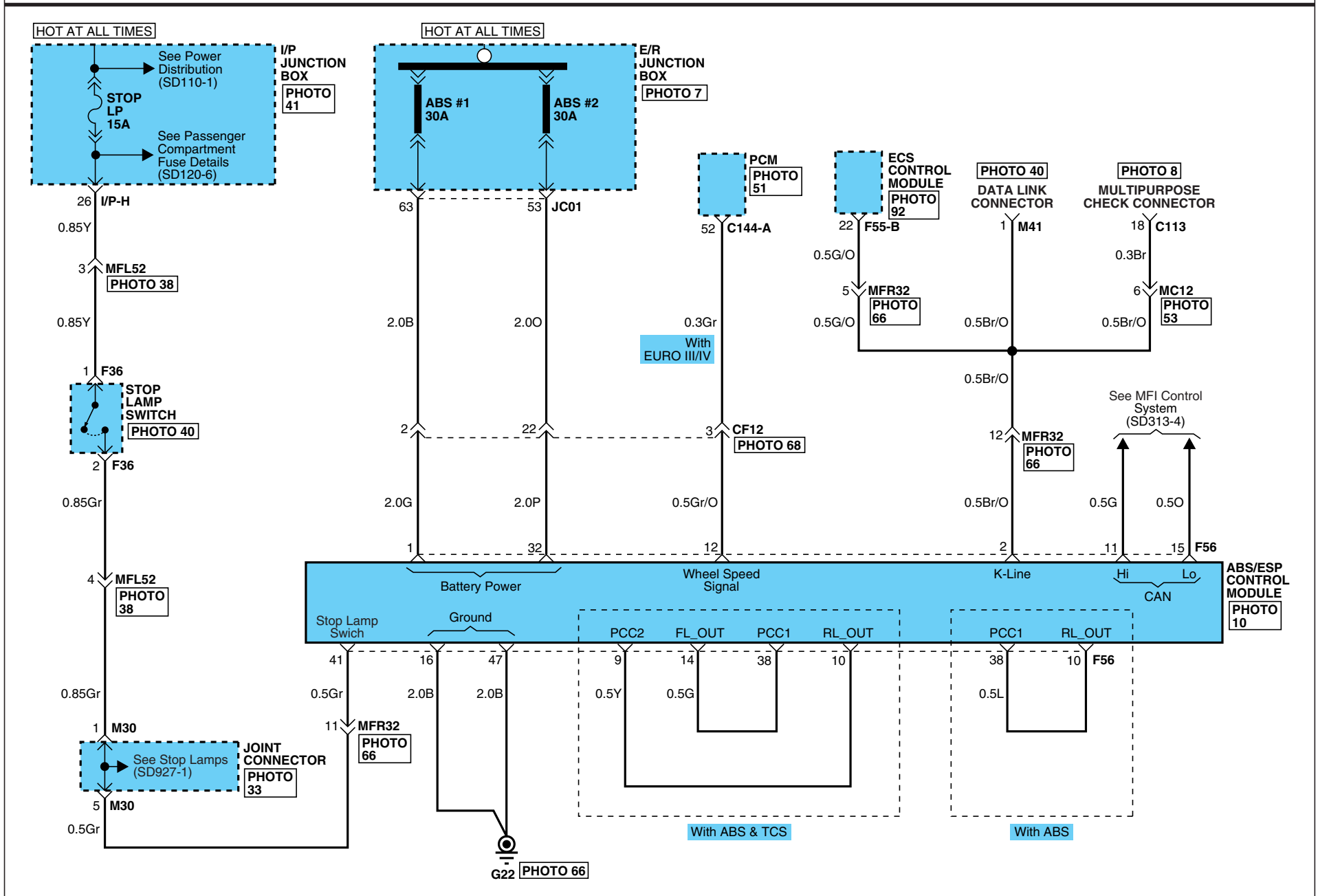

ANTI-LOCK BRAKE SYSTEM/ TRACTION CONTROL SYSTEM

ANTI-LOCK BRAKE SYSTEM/ TRACTION CONTROL SYSTEM (3)

SD587-3

C113

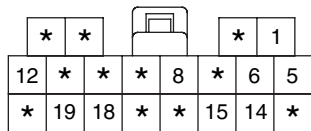

KET_DIAGNOSIS_20F_B_B

E08

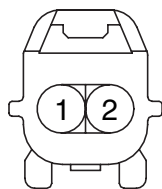

KET_SSD_02M_B

C144-A

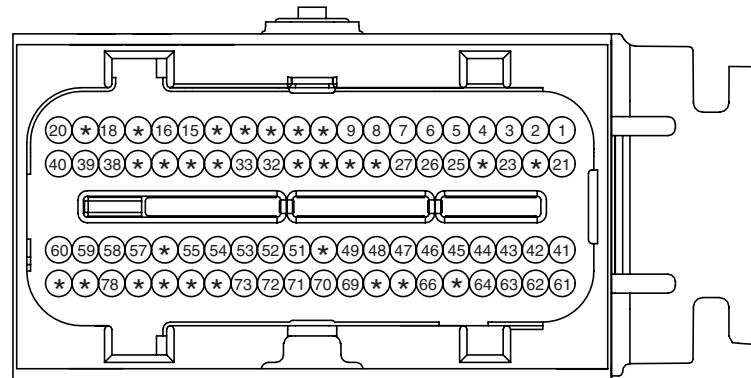

PKD_ECU_80F_GR_3

F27

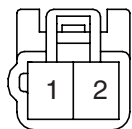

KET_090II_02M_W_R

F36

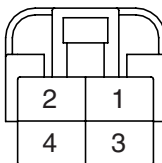

KET_250DL_04F_W

F55-B

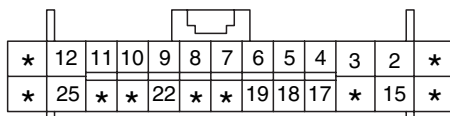

AMP_0407_26F_W_HD

F56

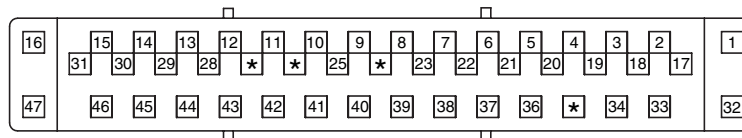

AMP_ESP_47F_L_UNIT

F60

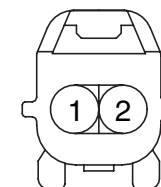

KET_SSD_02M_B

F69

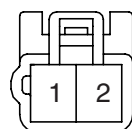

KET_090II_02M_W_R

M10-A

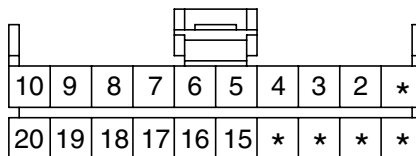

AMP_040M1_20F_B

M10-B

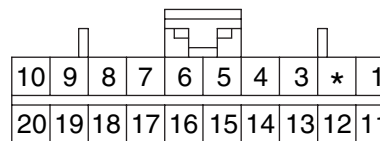

AMP_040M2_20F_B

M10-C

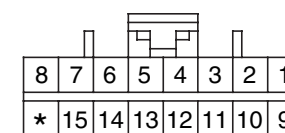

AMP_040M2_16F_B

M41

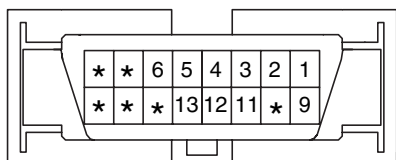

MLX_OBDII_16F_B_SIN

M61

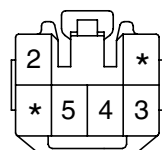

KET_090II_06F_R

BLANK

BLANK

ANTI-LOCK BRAKE SYSTEM/ TRACTION CONTROL SYSTEM

ANTI-LOCK BRAKE SYSTEM/ TRACTION CONTROL SYSTEM (4)

SD587-4

MEMO

ESP (ELECTRONIC STABILITY PROGRAM) SYSTEM

ESP (ELECTRONIC STABILITY PROGRAM) SYSTEM (2)

SD589-2

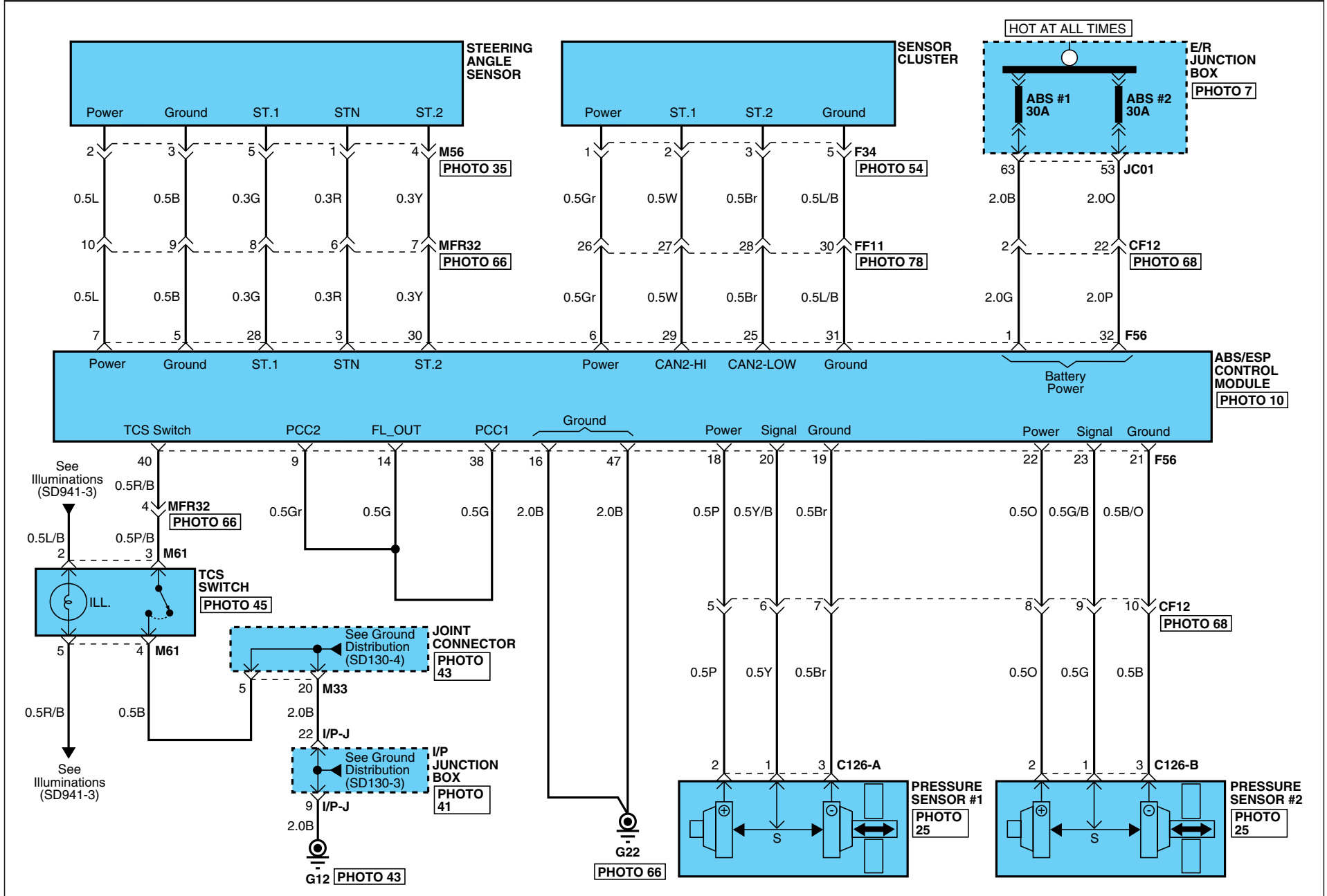

ESP (ELECTRONIC STABILITY PROGRAM) SYSTEM

ESP (ELECTRONIC STABILITY PROGRAM) SYSTEM (3)

SD589-3

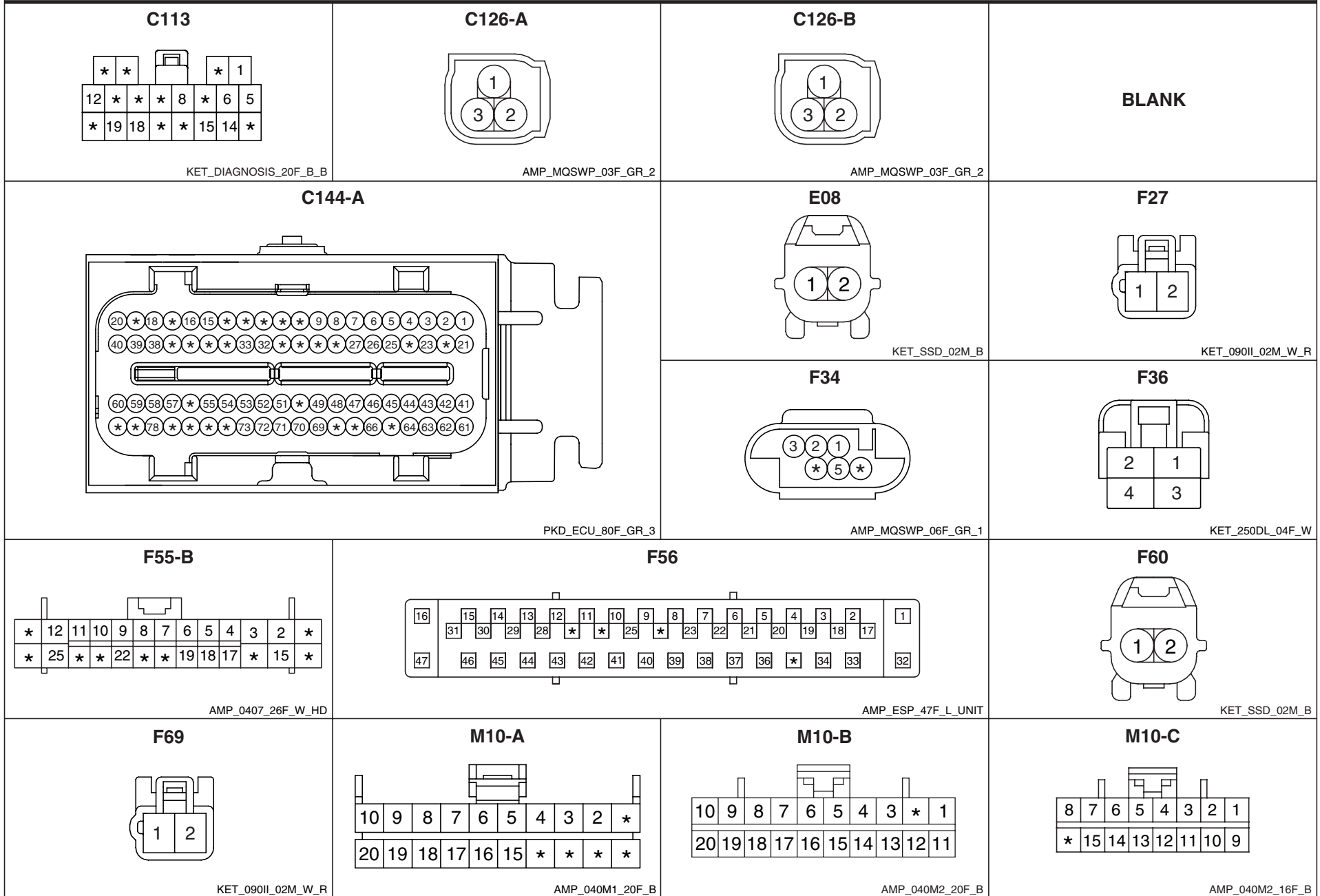

ESP (ELECTRONIC STABILITY PROGRAM) SYSTEM

ESP (ELECTRONIC STABILITY PROGRAM) SYSTEM (4)

SD589-4

M41

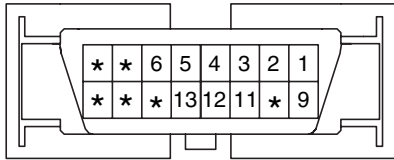

MLX_OBDII_16F_B_SIN

M56

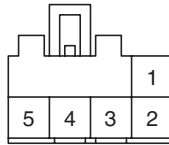

KUM_CDR_05F_W

M61

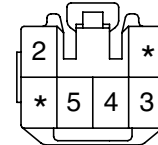

KET_090II_06F_R

BLANK

FUEL FILLER DOOR & TRUNK LID OPENER

FUEL FILLER DOOR & TRUNK LID OPENER (2)

SD812-2

D10-B

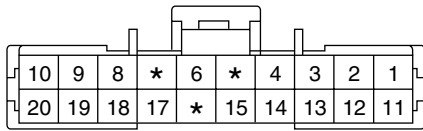

KET_SP_20F_W

D12

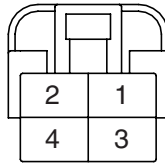

KET_250DL_04F_W

F13

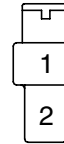

KET_250_02F_W

F23-A

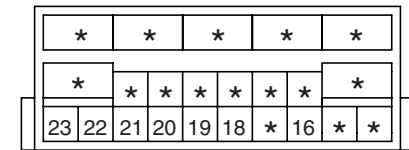

SIE_PIC_23F_GR

M05-B

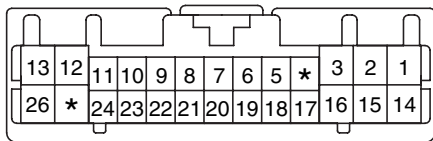

KET_0407_26F_W

M05-C

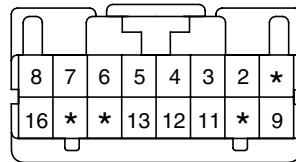

KET_0407_16F_W

M65-A

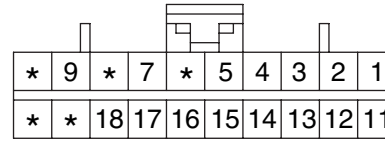

AMP_040M2_20F_B

M75

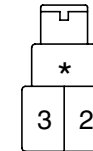

KET_250_03F_W

R05

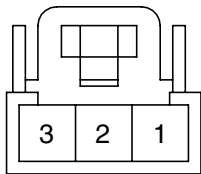

AMP_070_03F_W

R06

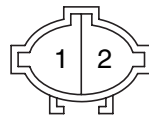

CR02M060

BLANK

BLANK

POWER DOOR LOCKS (1)

SD813-1

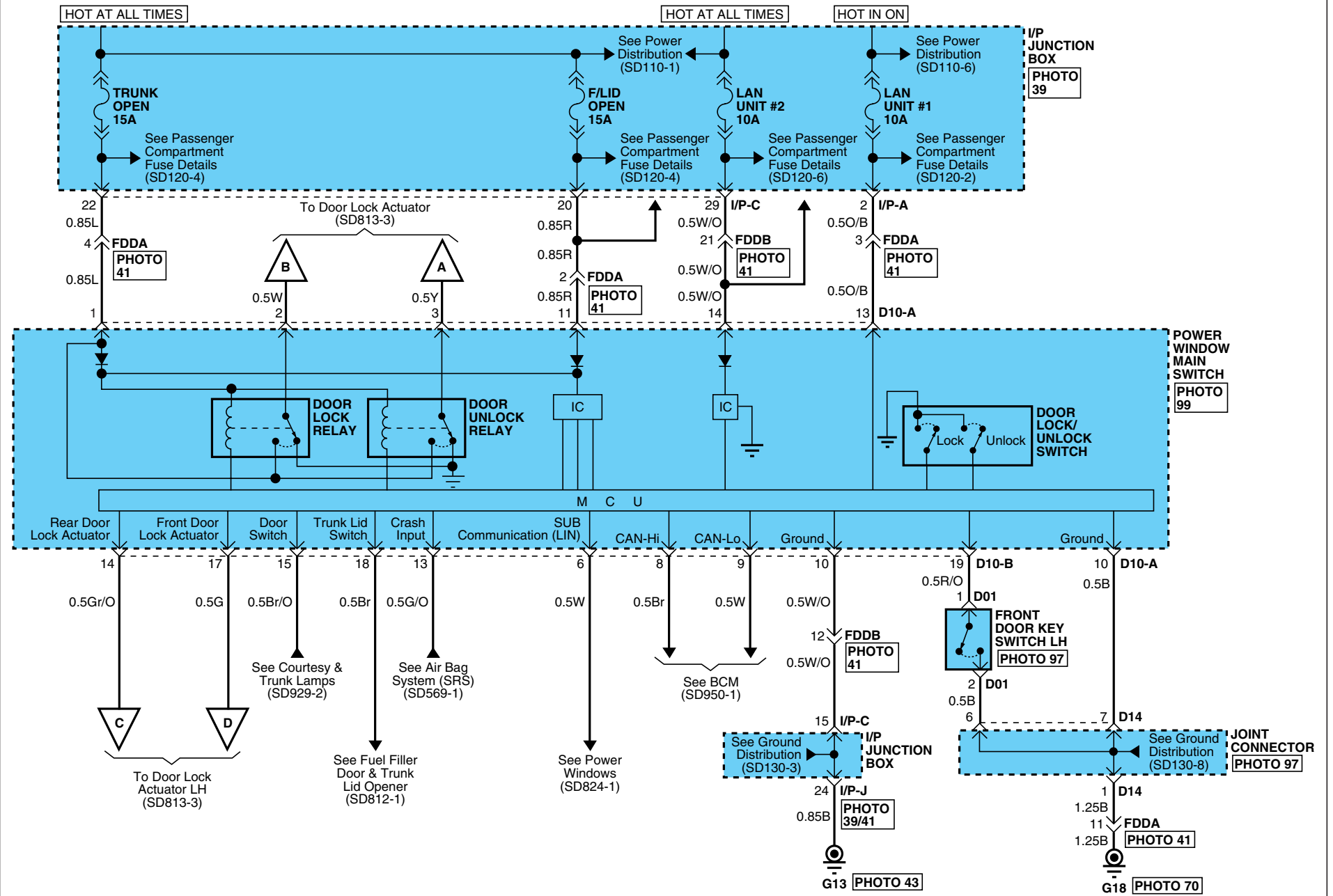

POWER DOOR LOCKS

POWER DOOR LOCKS (2)



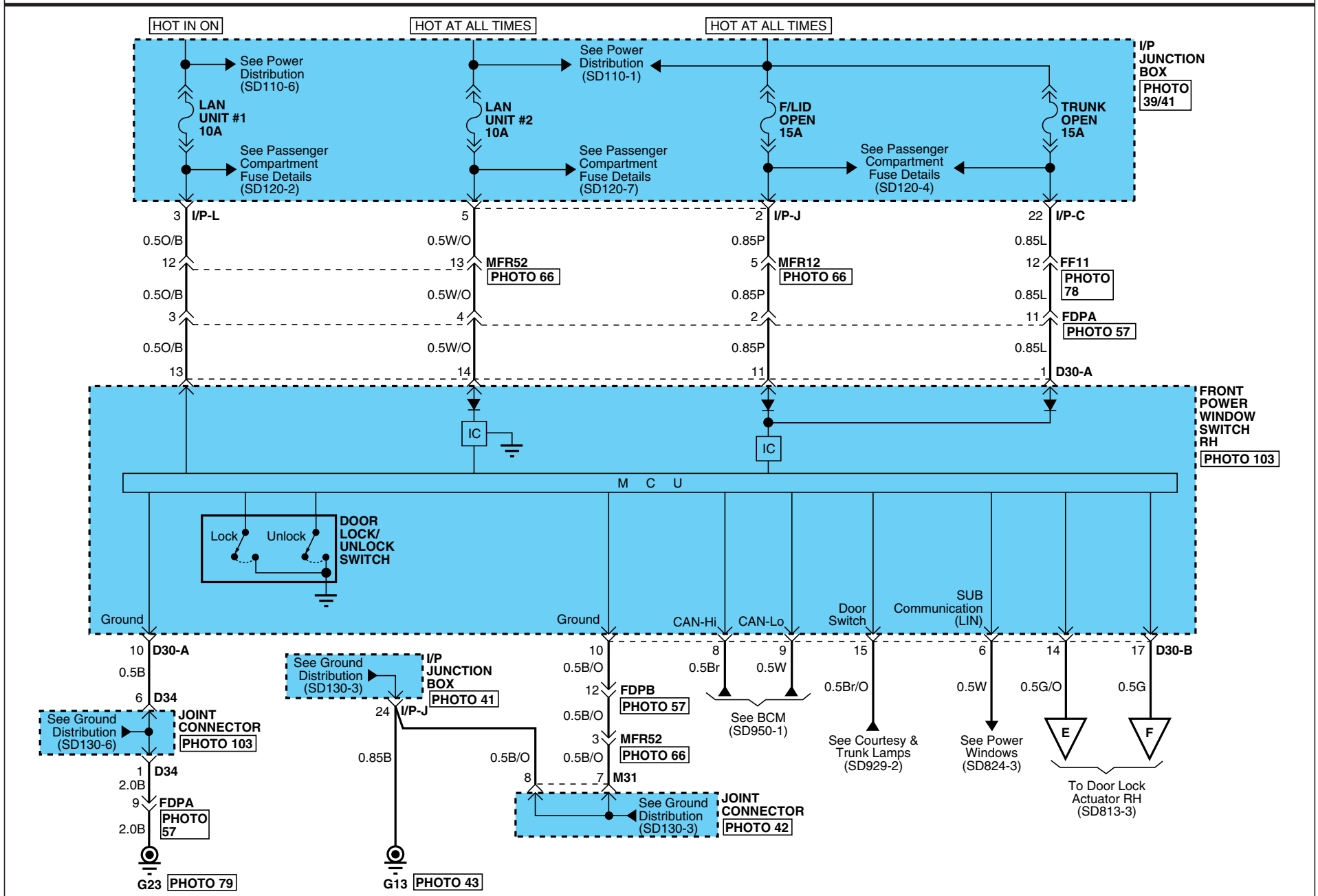



SD813-2

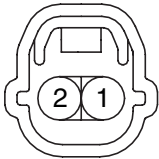

POWER DOOR LOCKS

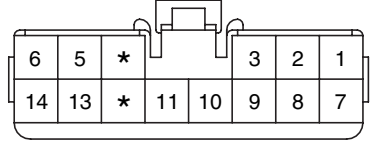
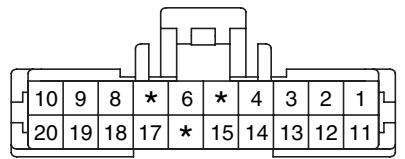
POWER DOOR LOCKS (4)

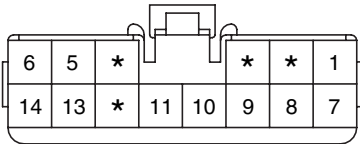
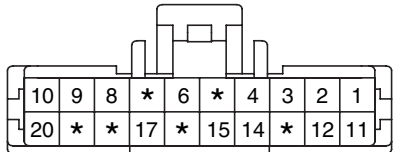
SD813-4

<p>D01</p>  <p>KET_SSD_02F_B</p>	<p>D03</p>  <p>KET_SSD_06F_B</p>	<p>D10-A</p>  <p>KET_090II_14F_W</p>	<p>D10-B</p>  <p>KET_SP_20F_W</p>
<p>D23</p>  <p>KET_SSD_06F_B</p>	<p>D30-A</p>  <p>KET_090II_14F_W</p>	<p>D30-B</p>  <p>KET_SP_20F_W</p>	<p>D41</p>  <p>KET_SSD_06F_B</p>
<p>D51</p>  <p>KET_SSD_06F_B</p>	<p>BLANK</p>	<p>BLANK</p>	<p>BLANK</p>

PIC (PERSONAL IC CARD) SYSTEM

PIC (PERSONAL IC CARD) SYSTEM (2)

SD815-2

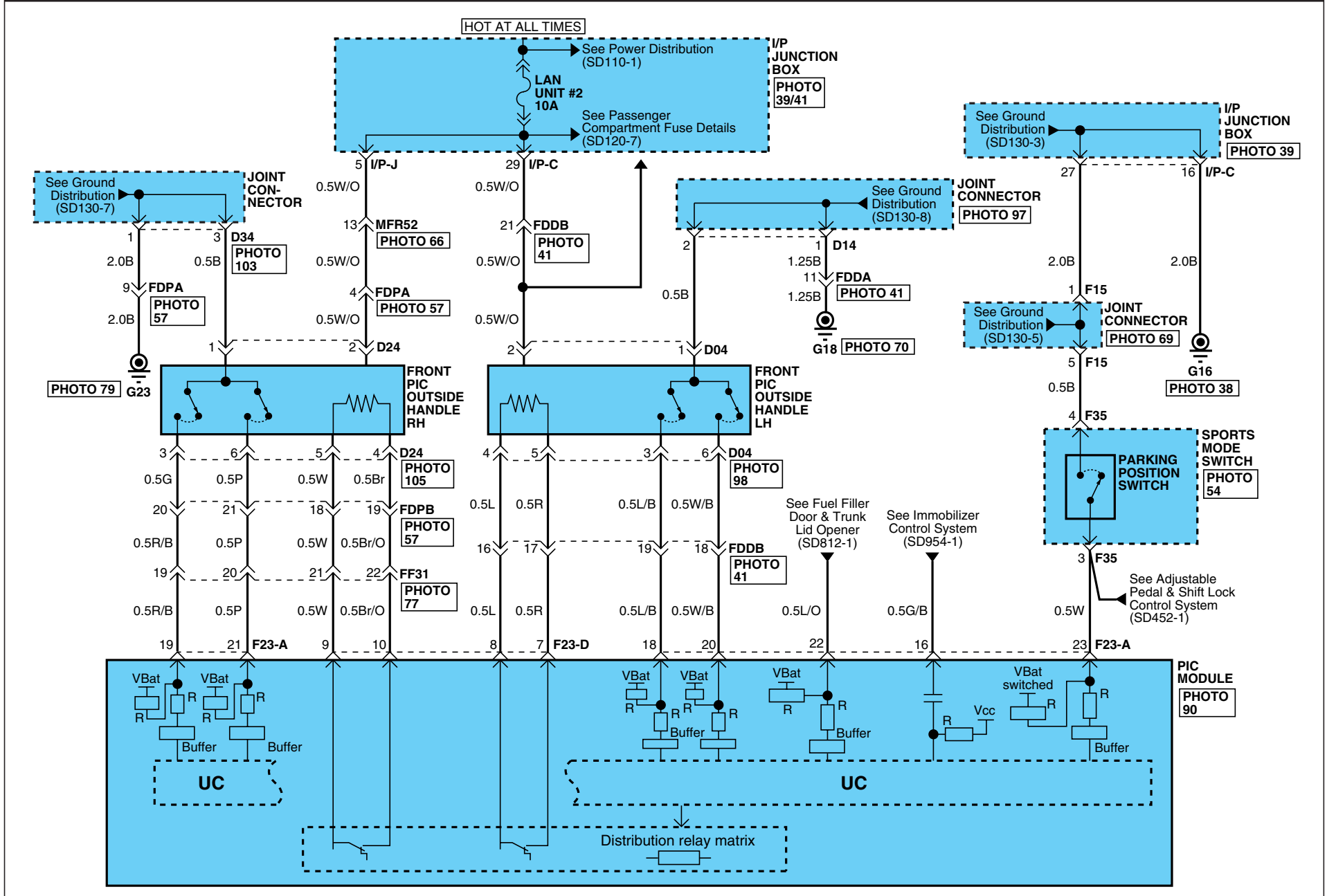

PIC (PERSONAL IC CARD) SYSTEM

PIC (PERSONAL IC CARD) SYSTEM (3)



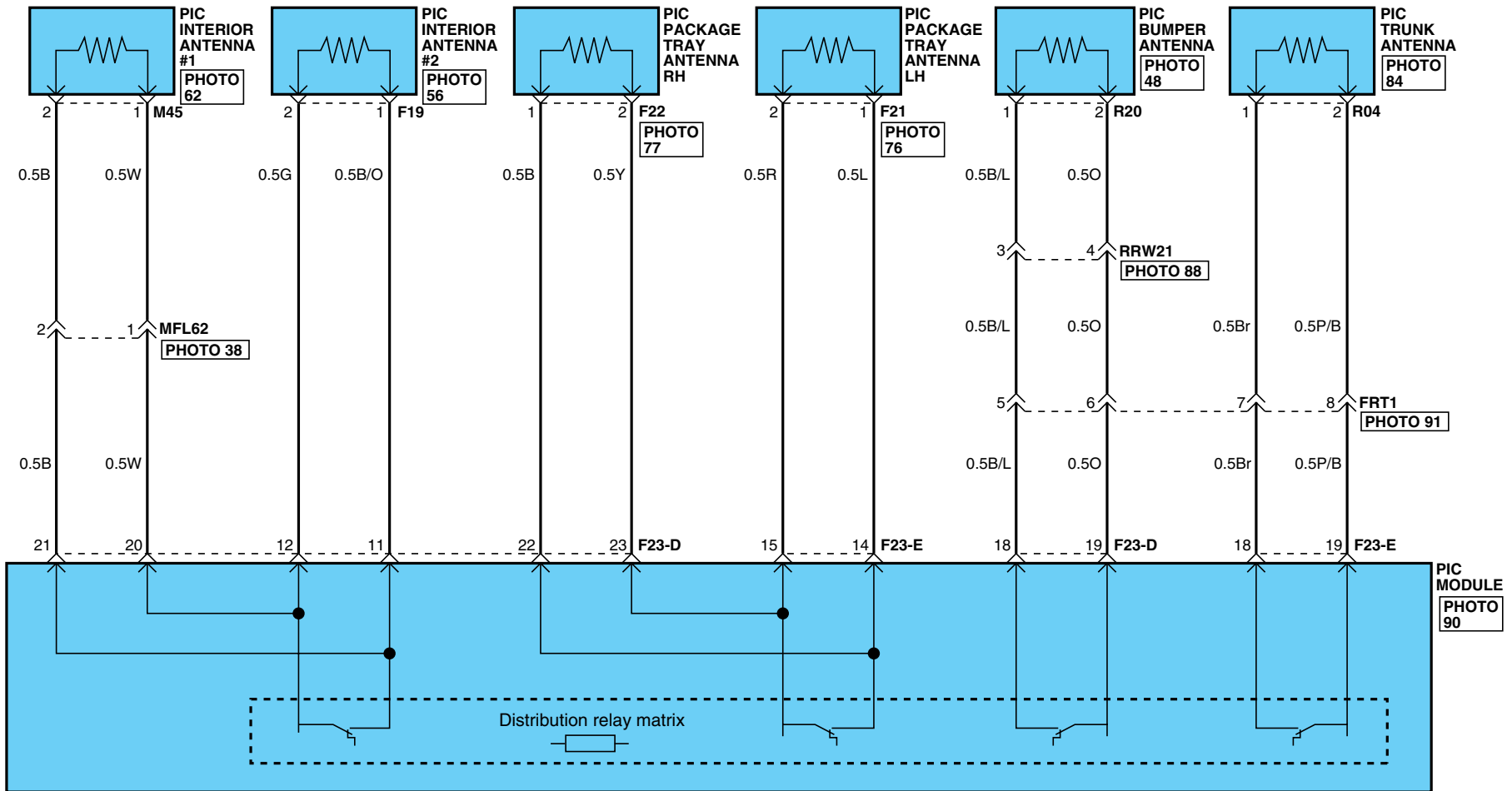



SD815-3

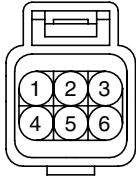

PIC (PERSONAL IC CARD) SYSTEM

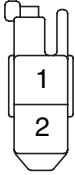
PIC (PERSONAL IC CARD) SYSTEM (4)

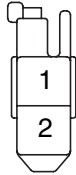
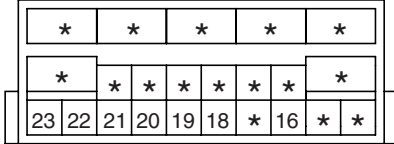
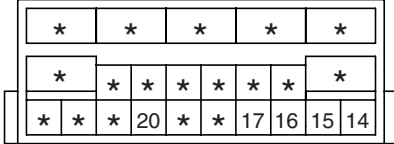
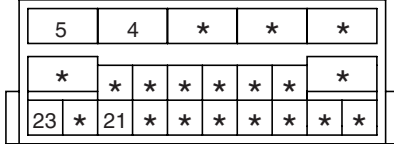
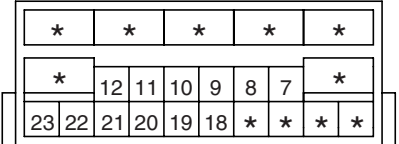
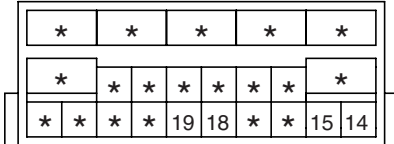
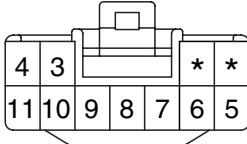
SD815-4

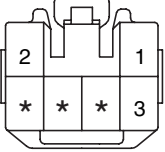
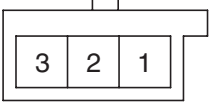
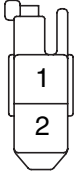
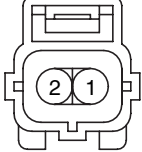
<p>D04</p>  <p>YAZ_040WP_06M_GY</p>	<p>D24</p>  <p>YAZ_040WP_06M_GY</p>	<p>F19</p>  <p>KET_090II_02F_W_SPK</p>	<p>F21</p>  <p>KET_090II_02F_W_SPK</p>
<p>F22</p>  <p>KET_090II_02F_W_SPK</p>	<p>F23-A</p>  <p>SIE_PIC_23F_GR</p>	<p>F23-B</p>  <p>SIE_PIC_23F_G</p>	<p>F23-C</p>  <p>SIE_PIC_23F_L</p>
<p>F23-D</p>  <p>SIE_PIC_23F_W</p>	<p>F23-E</p>  <p>SIE_PIC_23F_BR</p>	<p>F35</p>  <p>KET_090II_11F_W</p>	<p>M45</p>  <p>KET_090II_02F_W_SPK</p>
<p>M47</p>  <p>KET_090II_06F_W</p>	<p>M49</p>  <p>AMP_025_03F_G</p>	<p>R04</p>  <p>KET_090II_02F_W_SPK</p>	<p>R20</p>  <p>AMP_EJWP_02F_B</p>
Empty row			

SUNROOF (1)

SD816-1

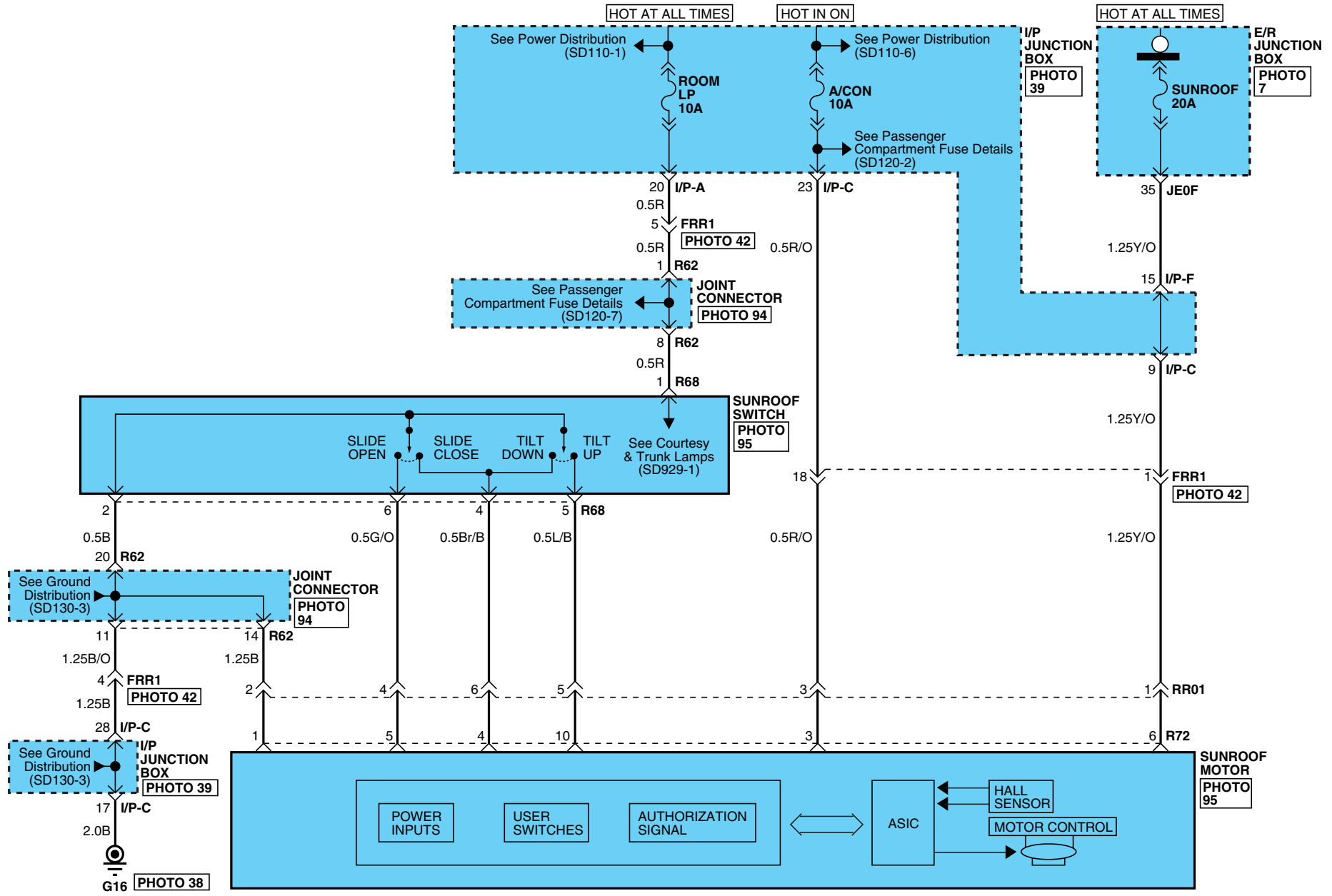

SUNROOF

SUNROOF (2)

SD816-2

R68

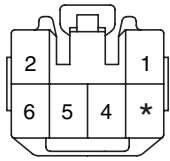

KET_090II_06F_W

R72

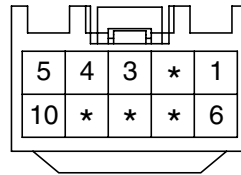

YAZ_1.5SYS_10F_W

BLANK

BLANK

POWER WINDOWS (1)

SD824-1

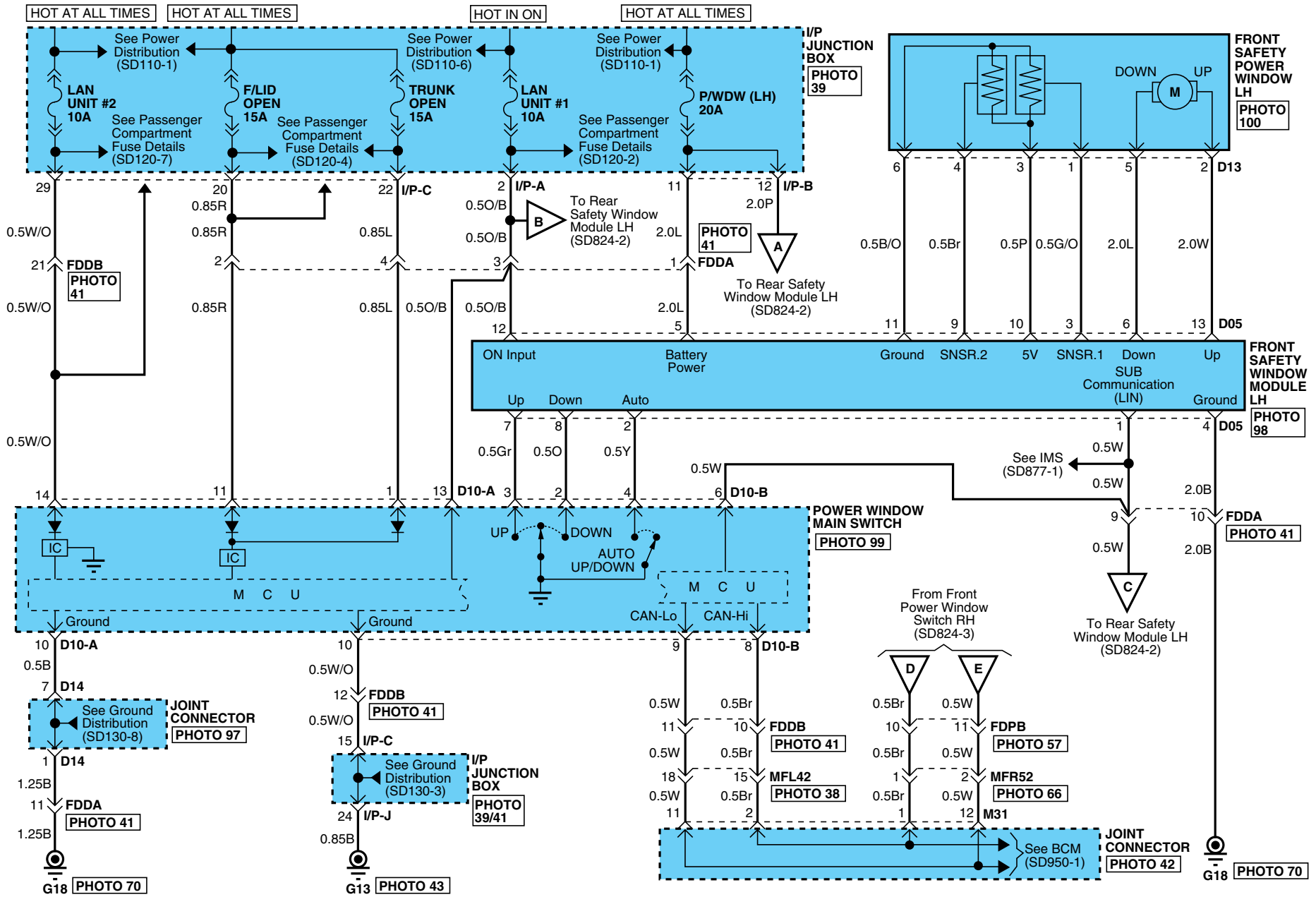

POWER WINDOWS

POWER WINDOWS (2)

SD824-2

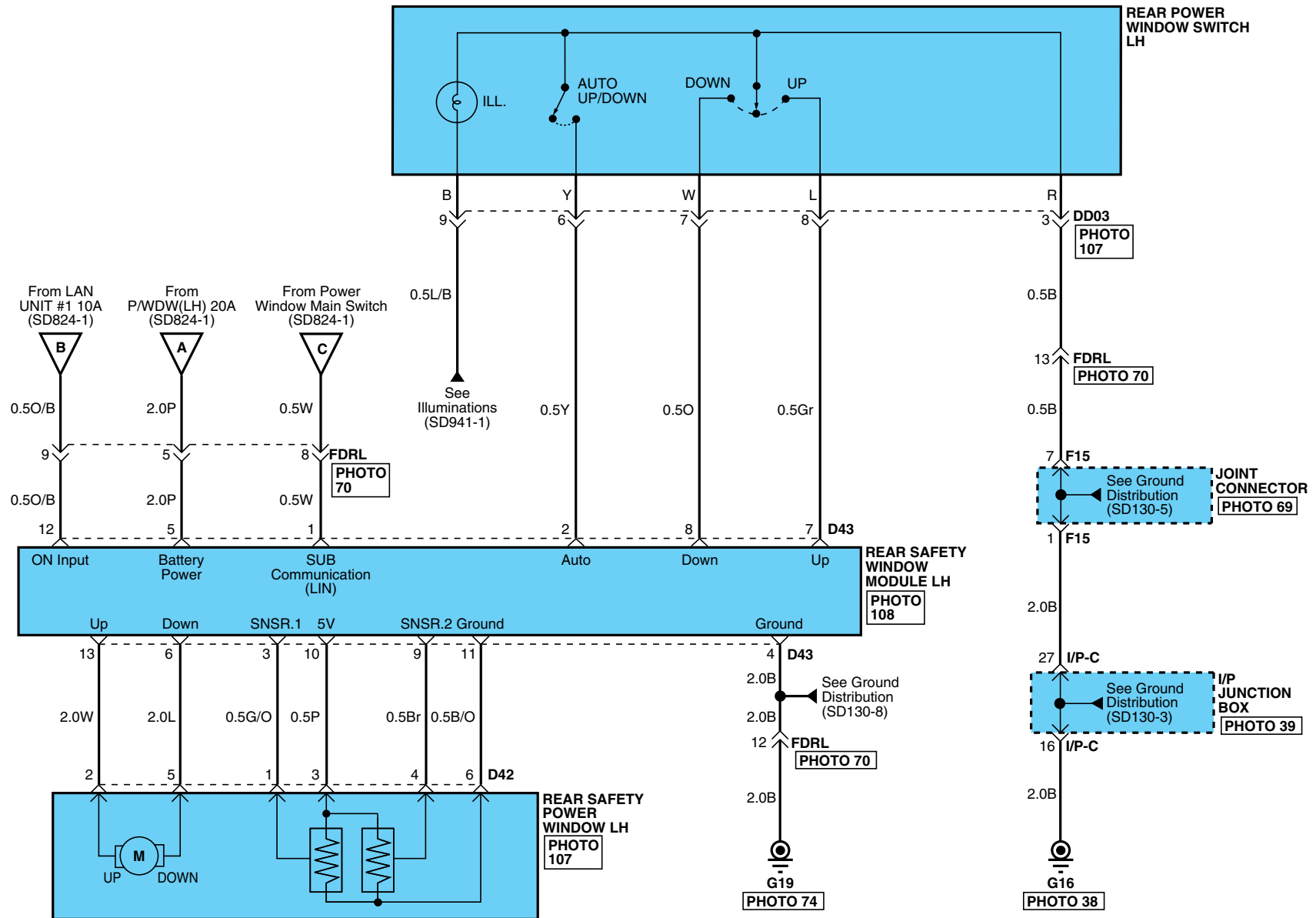

POWER WINDOWS

POWER WINDOWS (4)

SD824-4

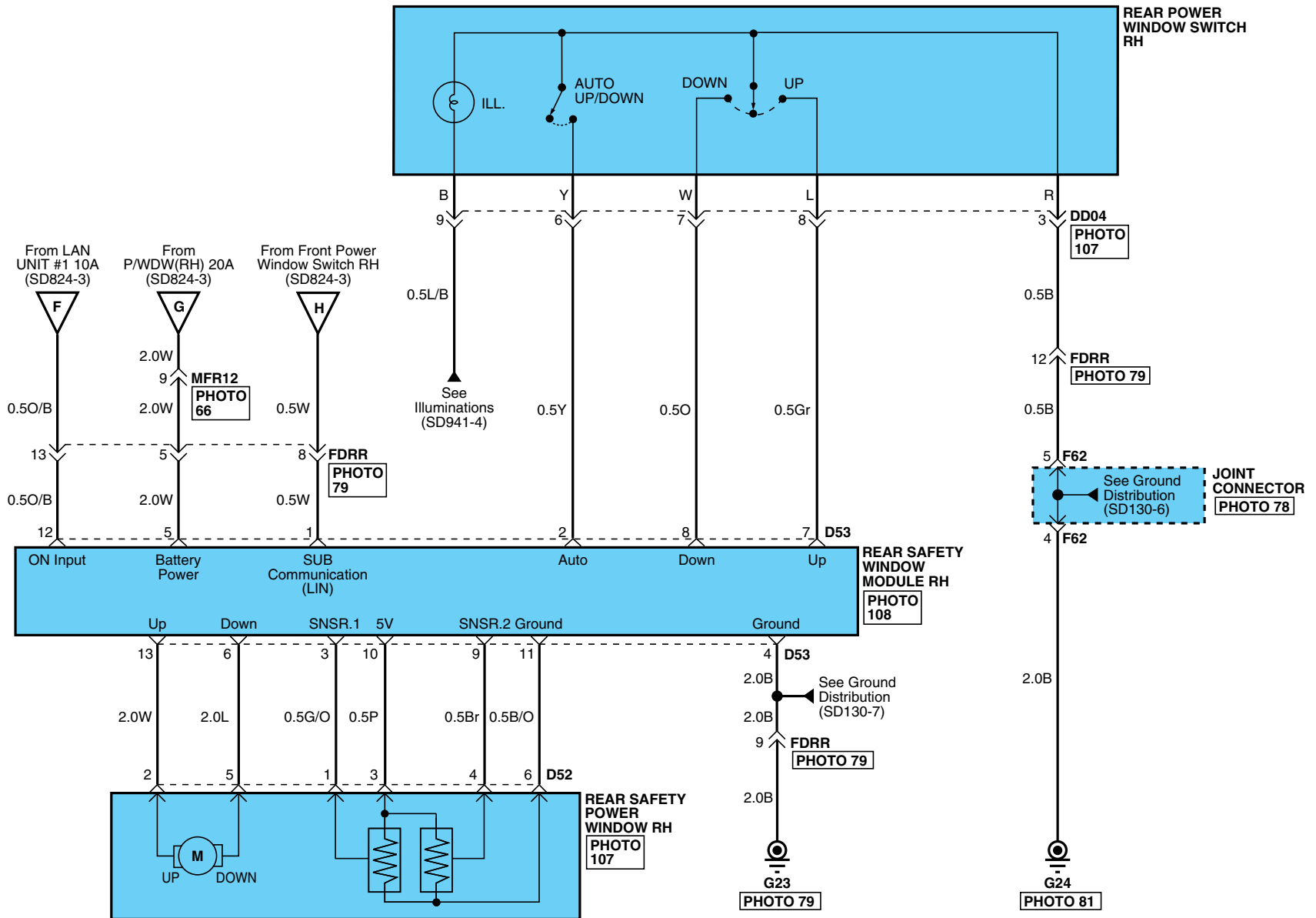

POWER WINDOWS

POWER WINDOWS (5)

SD824-5

D05

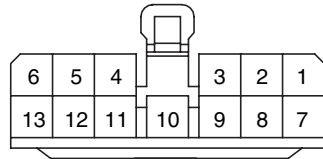

AMP_MIC_13F_W

D10-A

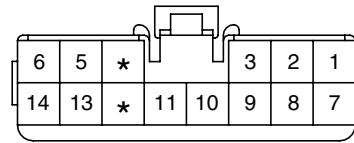

KET_090_14F_W

D10-B

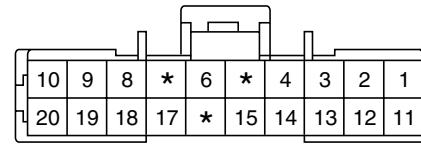

KET_SP_20F_W

D13

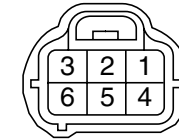

KET_090IWP_06F_Gr

D25

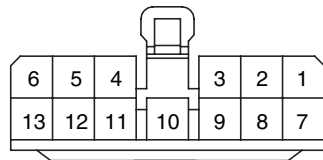

AMP_MIC_13F_W

D30-A

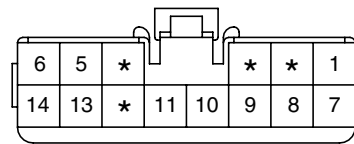

KET_090II_14F_W

D30-B

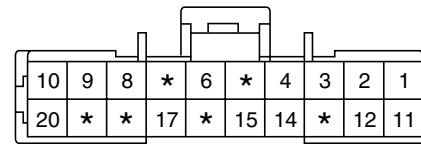

KET_SP_20F_W

D33

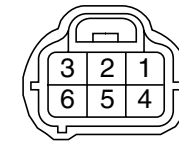

KET_090IWP_06F_Gr

D42

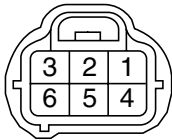

KET_090IWP_06F_Gr

D43

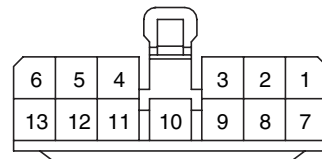

AMP_MIC_13F_W

D52

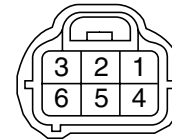

KET_090IWP_06F_Gr

D53

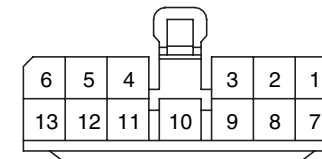

AMP_MIC_13F_W

POWER WINDOWS

POWER WINDOWS (6)

SD824-6

MEMO

CIGARETTE LIGHTER & POWER OUTLET (1)

SD846-1

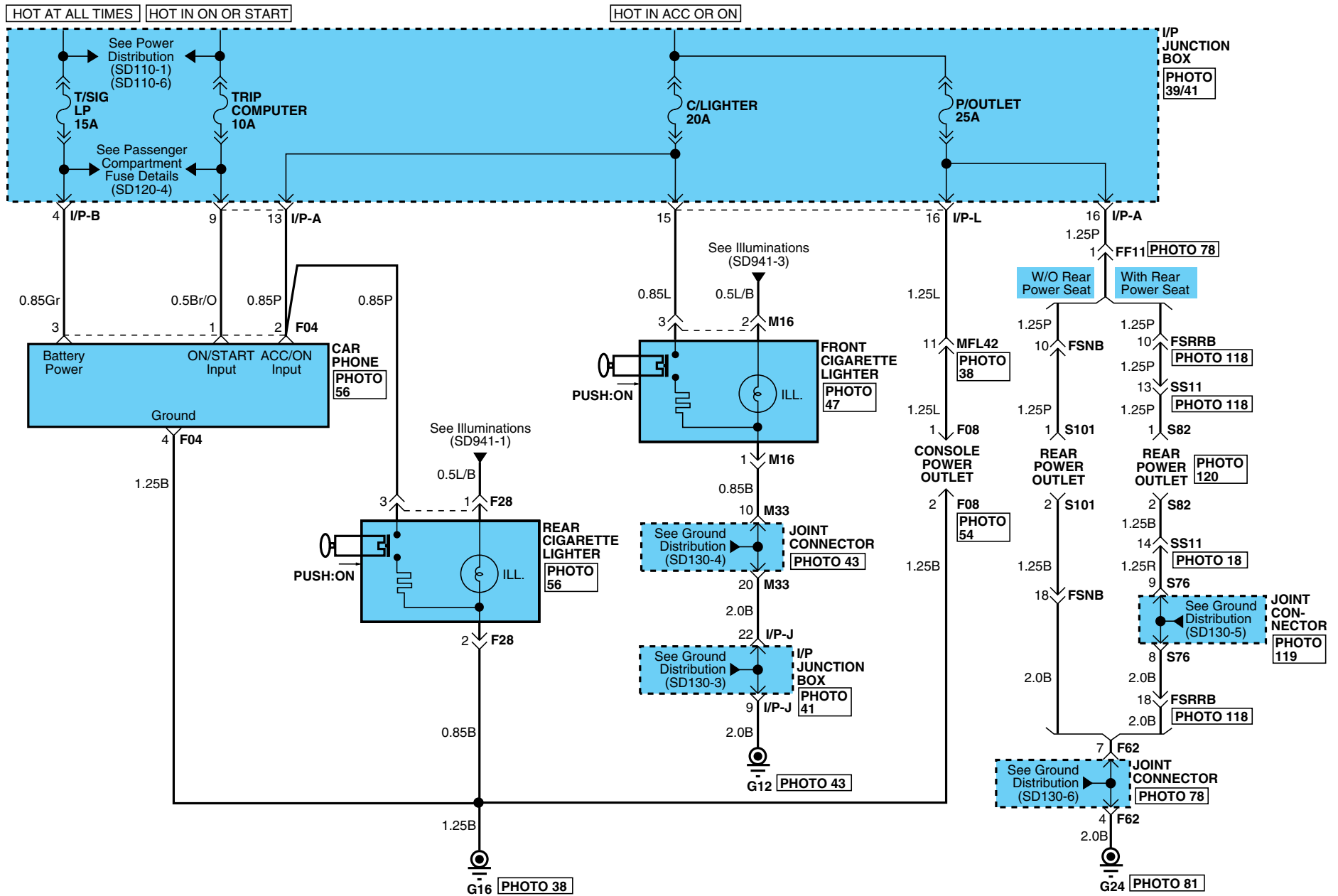

CIGARETTE LIGHTER & POWER OUTLET

CIGARETTE LIGHTER & POWER OUTLET (2)

SD846-2

F04

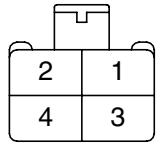

KET_250_04F_W

F08

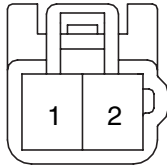

KET_090II_02M_B_L

F28

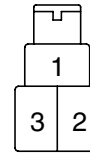

KET_250_03F_W

M16

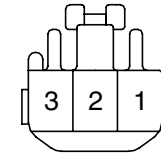

KET_090II_03F_W

S82

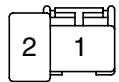

AMP_PLM2_02F_B

S101

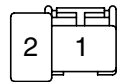

AMP_PLM2_02F_B

BLANK

BLANK

ELECTRO CHROMIC MIRROR

ELECTRO CHROMIC MIRROR (2)

SD851-2

C109



KET_SSD_10F_B_A

D09

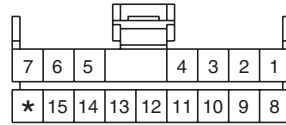

AMP_040III_16F_W

D29

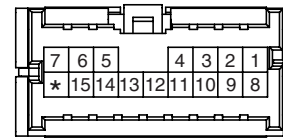

AMP_040III_16F_W

R59

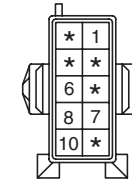

AMP_MQS_10F_B

REAR CURTAIN

REAR CURTAIN (2)

SD856-2

F82

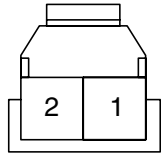

AMP_070_02F

M10-B

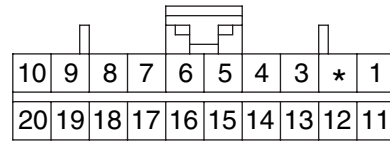

AMP_040M2_20F_B

M51

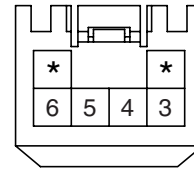

AMP_090III_06F_L_2

M91

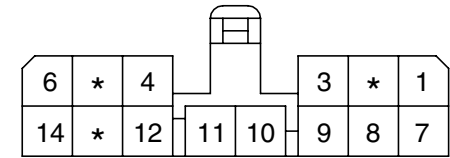

AMP_070_14F_W

POWER OUTSIDE MIRROR & MIRROR FOLDING

POWER OUTSIDE MIRROR & MIRROR FOLDING (2)

SD876-2

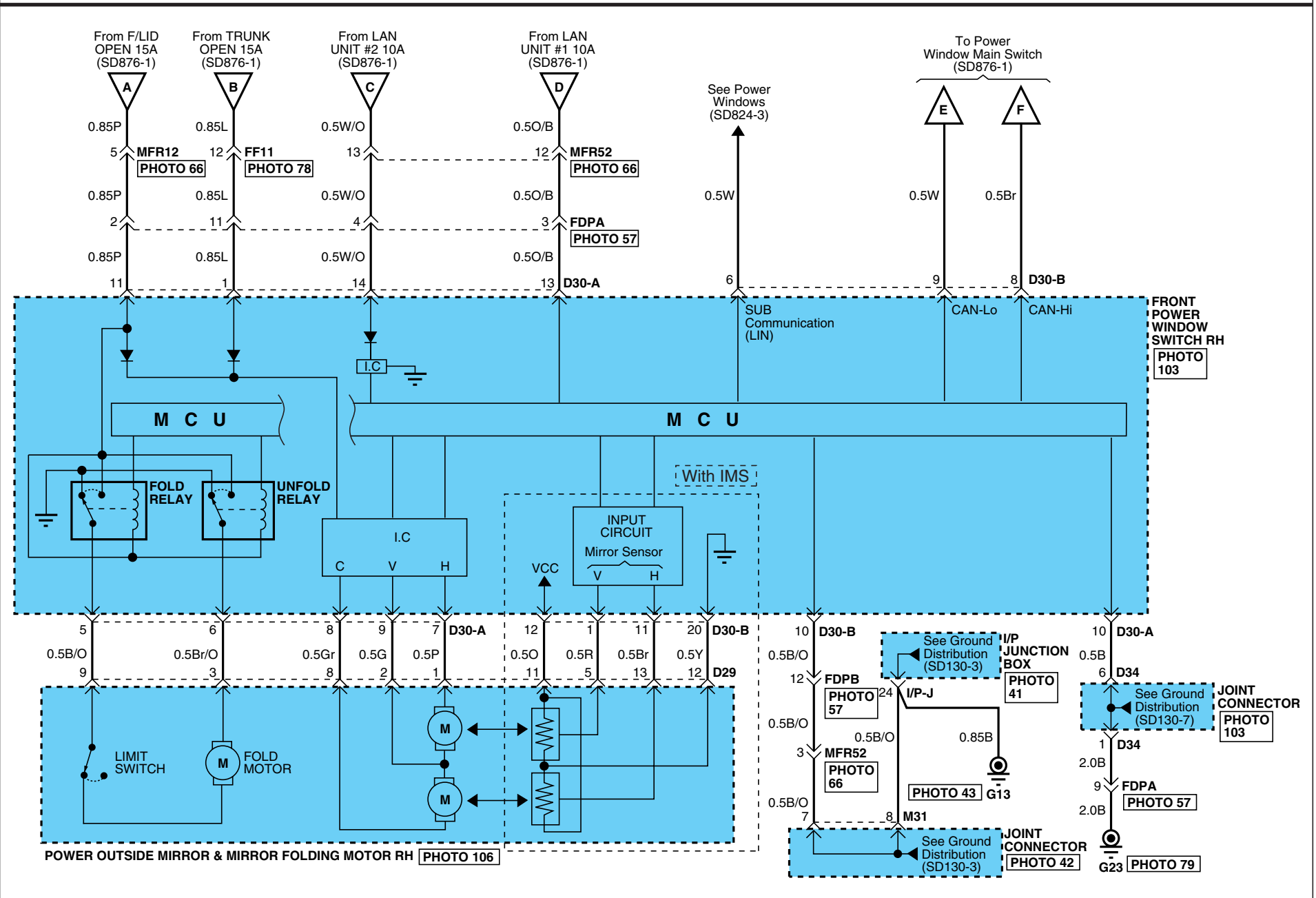

POWER OUTSIDE MIRROR & MIRROR FOLDING

POWER OUTSIDE MIRROR & MIRROR FOLDING (3)

SD876-3

D09

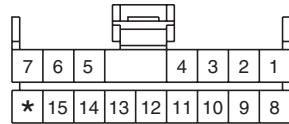

AMP_040III_16F_W

D10-A

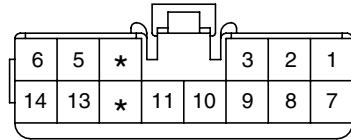

KET_090II_14F_W

D10-B

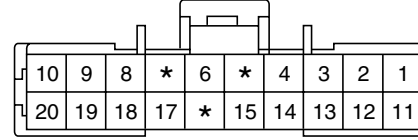

KET_SP_20F_W

D29

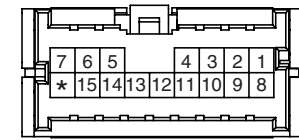

AMP_040III_16F_W

D30-A

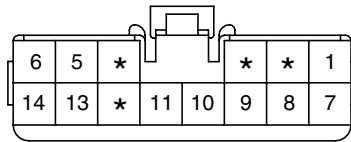

KET_090II_14F_W

D30-B

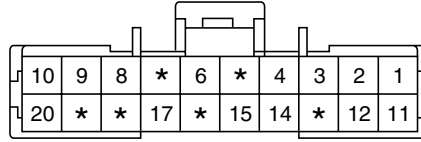

KET_SP_20F_W

BLANK

BLANK

POWER OUTSIDE MIRROR & MIRROR FOLDING

POWER OUTSIDE MIRROR & MIRROR FOLDING (4)

SD876-4

MEMO

IMS (INTEGRATED MEMORY SYSTEM) (1)

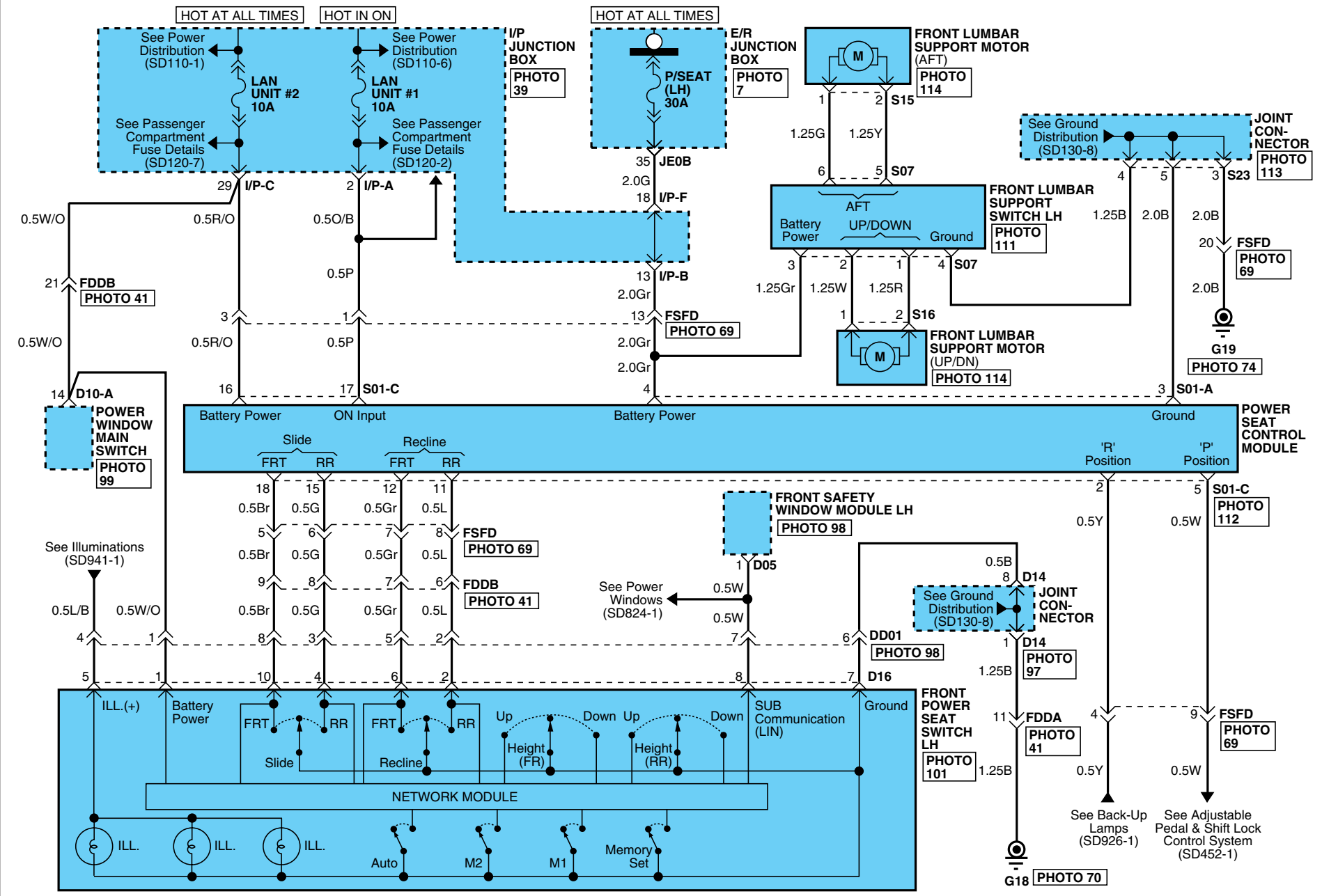



IMS (INTEGRATED MEMORY SYSTEM)

IMS (INTEGRATED MEMORY SYSTEM) (2)

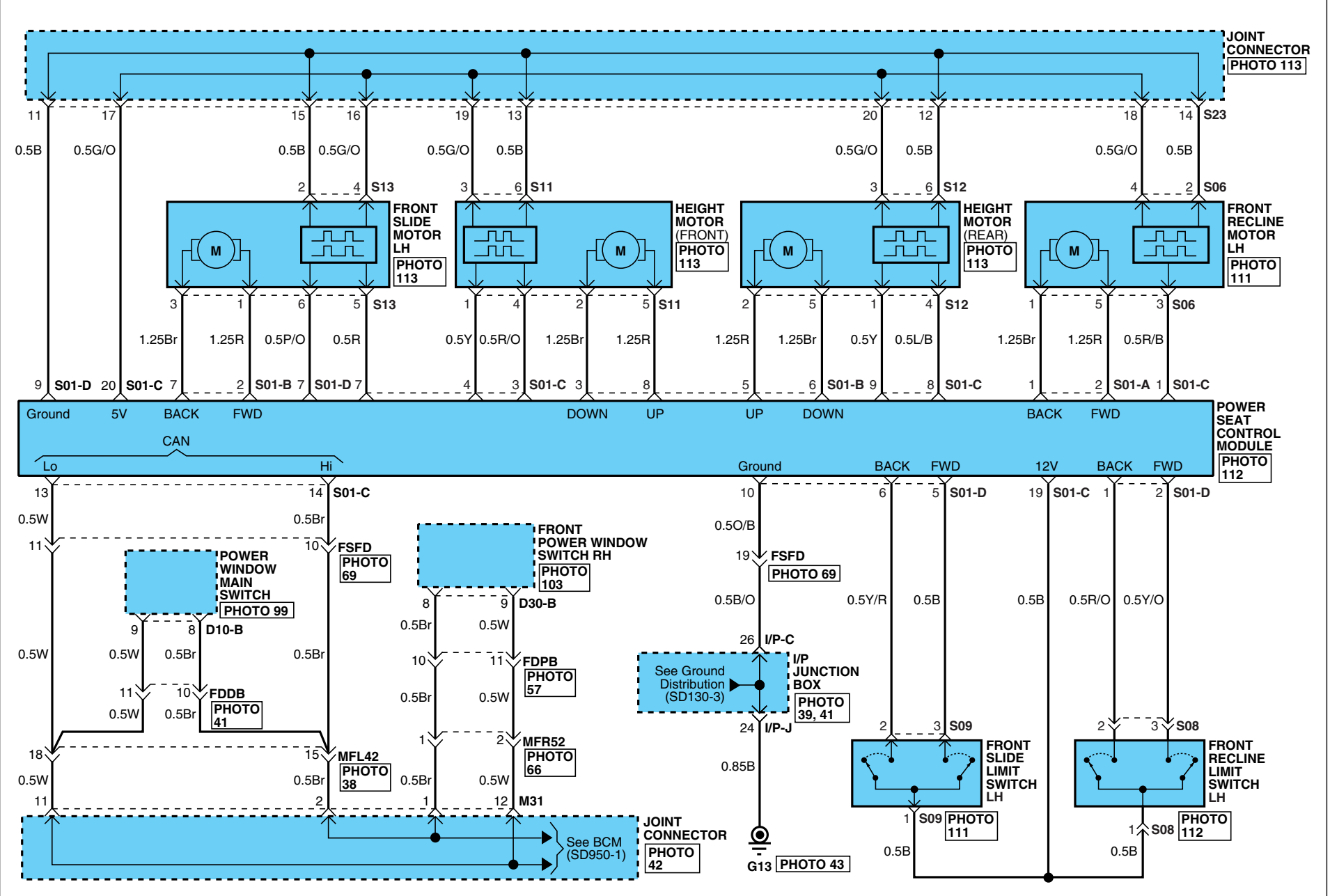
SD877-2

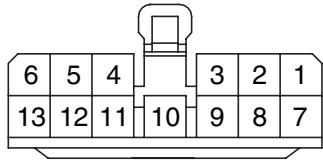
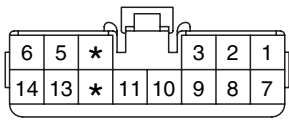
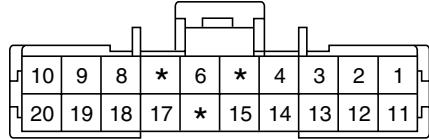
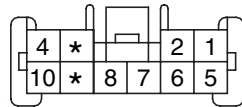
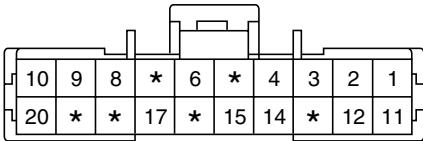
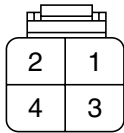
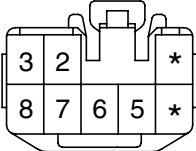
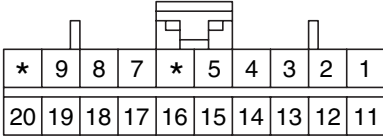
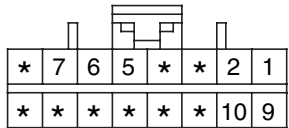
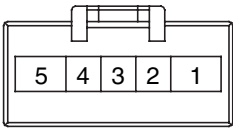
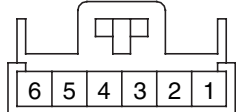
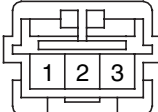
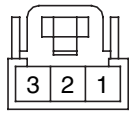

IMS (INTEGRATED MEMORY SYSTEM)

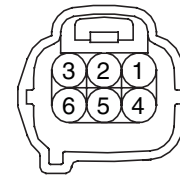
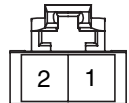
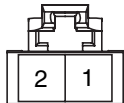
IMS (INTEGRATED MEMORY SYSTEM) (3)			SD877-3
<p>D05</p>  <p>AMP_MIC_13F_W</p>	<p>D10-A</p>  <p>KET_090II_14F_W</p>	<p>D10-B</p>  <p>KET_SP_20F_W</p>	<p>D16</p>  <p>KET_MG_610404</p>
<p>D30-B</p>  <p>KET_SP_20F_W</p>	<p>S01-A</p>  <p>AMP_250_04F</p>	<p>S01-B</p>  <p>KET_SDLII_08F</p>	<p>S01-C</p>  <p>AMP_040MII_20F</p>
<p>S01-D</p>  <p>AMP_040MII_16F</p>	<p>S06</p>  <p>AMP_MQS_05F_B</p>	<p>S07</p>  <p>AMP_070_06F_W</p>	<p>S08</p>  <p>AMP_070_03M</p>
<p>S09</p>  <p>AMP_070_03F</p>	<p>S11</p>  <p>KET_090IWP_06F_W</p>	<p>S12</p>  <p>KET_090IWP_06F_W</p>	<p>S13</p>  <p>KET_090IWP_06F_W</p>
<p>S15</p>  <p>PKD_MP_480_02F</p>	<p>S16</p>  <p>PKD_MP_480_02F</p>	<p>BLANK</p>	<p>BLANK</p>

IMS (INTEGRATED MEMORY SYSTEM)

IMS (INTEGRATED MEMORY SYSTEM) (4)

SD877-4

MEMO

GLASS & OUTSIDE MIRROR DEFOGGER (1)

SD879-1

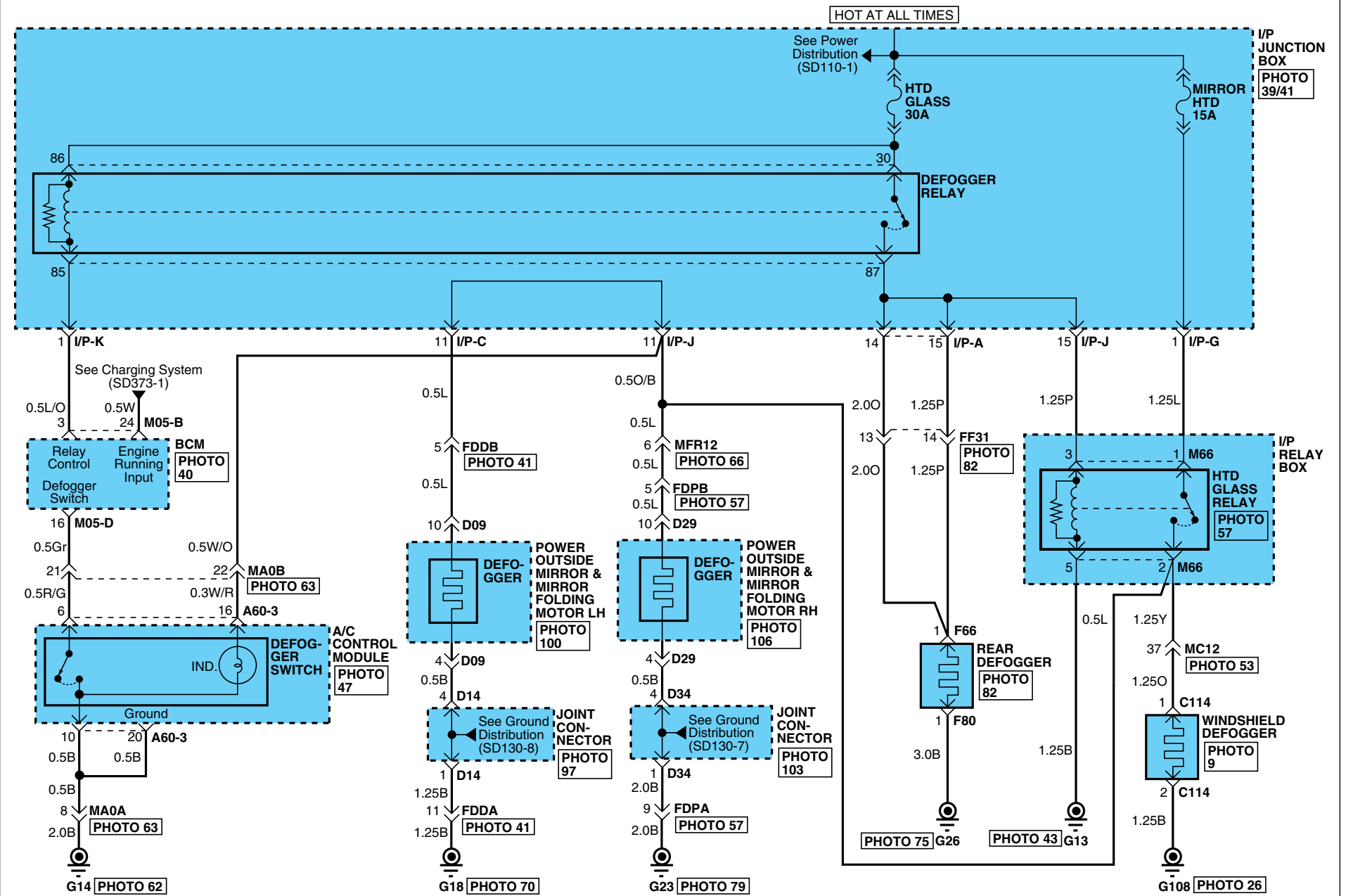

GLASS & OUTSIDE MIRROR DEFOGGER

GLASS & OUTSIDE MIRROR DEFOGGER (2)

SD879-2

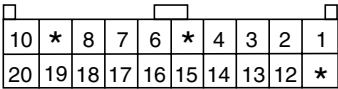
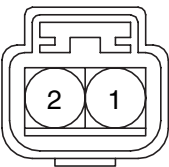
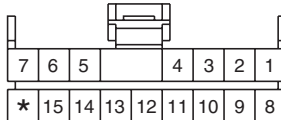
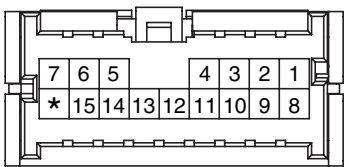
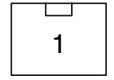
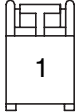
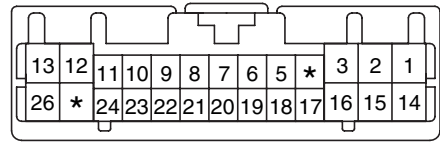
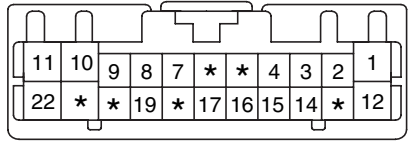
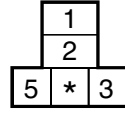
<p style="text-align: center;">A60-3</p>  <p style="text-align: right; font-size: small;">CR20F016</p>	<p style="text-align: center;">C114</p>  <p style="text-align: right; font-size: small;">KUM_NMWP_02F_B</p>	<p style="text-align: center;">D09</p>  <p style="text-align: right; font-size: small;">AMP_040III_16F_W</p>	<p style="text-align: center;">D29</p>  <p style="text-align: right; font-size: small;">AMP_040III_16F_W</p>
<p style="text-align: center;">F66</p>  <p style="text-align: right; font-size: small;">AMP_PLM1_01F_B</p>	<p style="text-align: center;">F80</p>  <p style="text-align: right; font-size: small;">AMP_PLM2_01F_B</p>	<p style="text-align: center;">M05-B</p>  <p style="text-align: right; font-size: small;">KET_0407_26F_W</p>	<p style="text-align: center;">M05-D</p>  <p style="text-align: right; font-size: small;">KET_0407_22F_W</p>
<p style="text-align: center;">M66</p>  <p style="text-align: right; font-size: small;">CR05F011</p>	<p style="text-align: center;">BLANK</p>	<p style="text-align: center;">BLANK</p>	<p style="text-align: center;">BLANK</p>

DRIVER POWER SEAT

E76A95E6

DRIVER POWER SEAT (W/O IMS) (1)

SD880-1

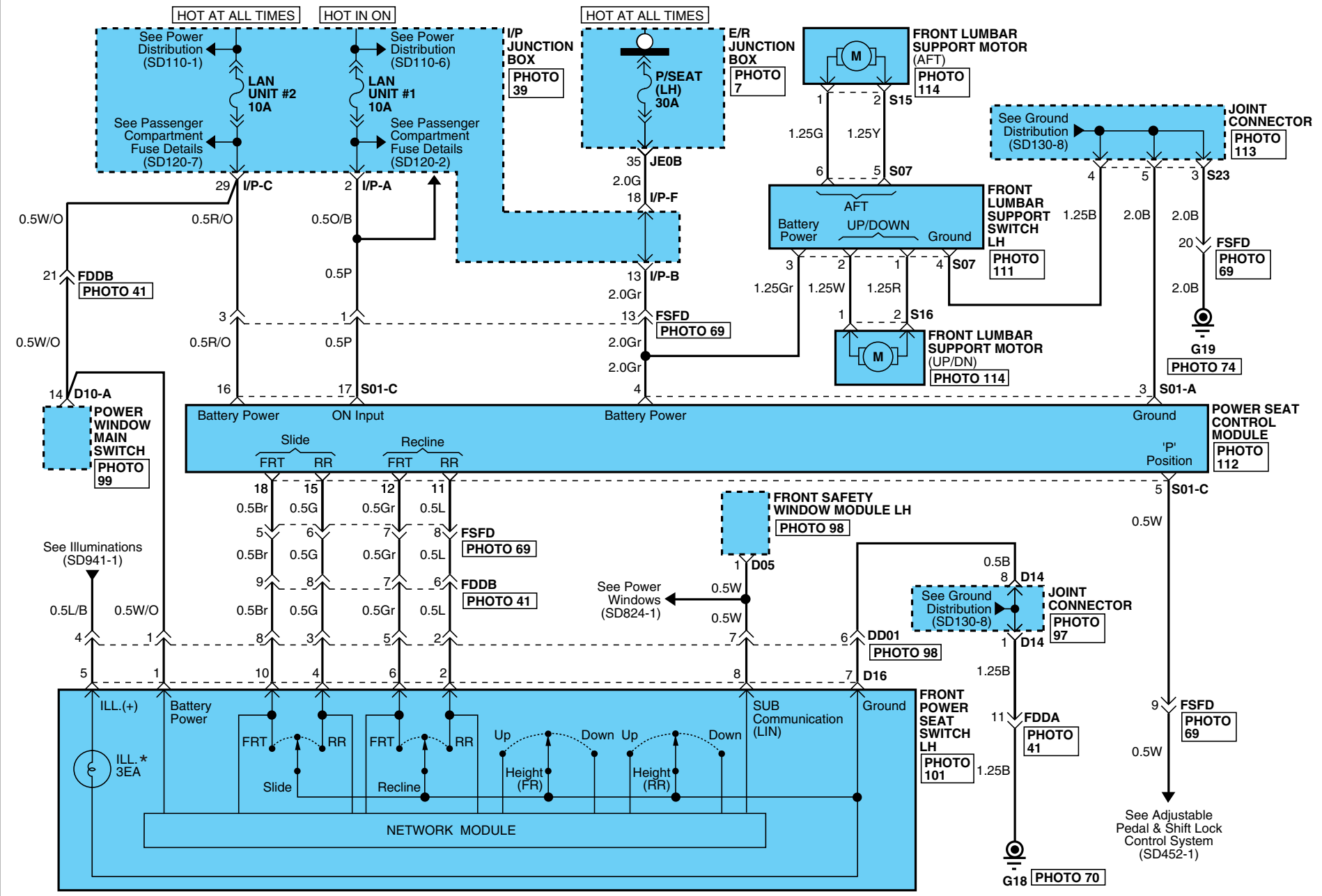

DRIVER POWER SEAT

DRIVER POWER SEAT (W/O IMS) (2)

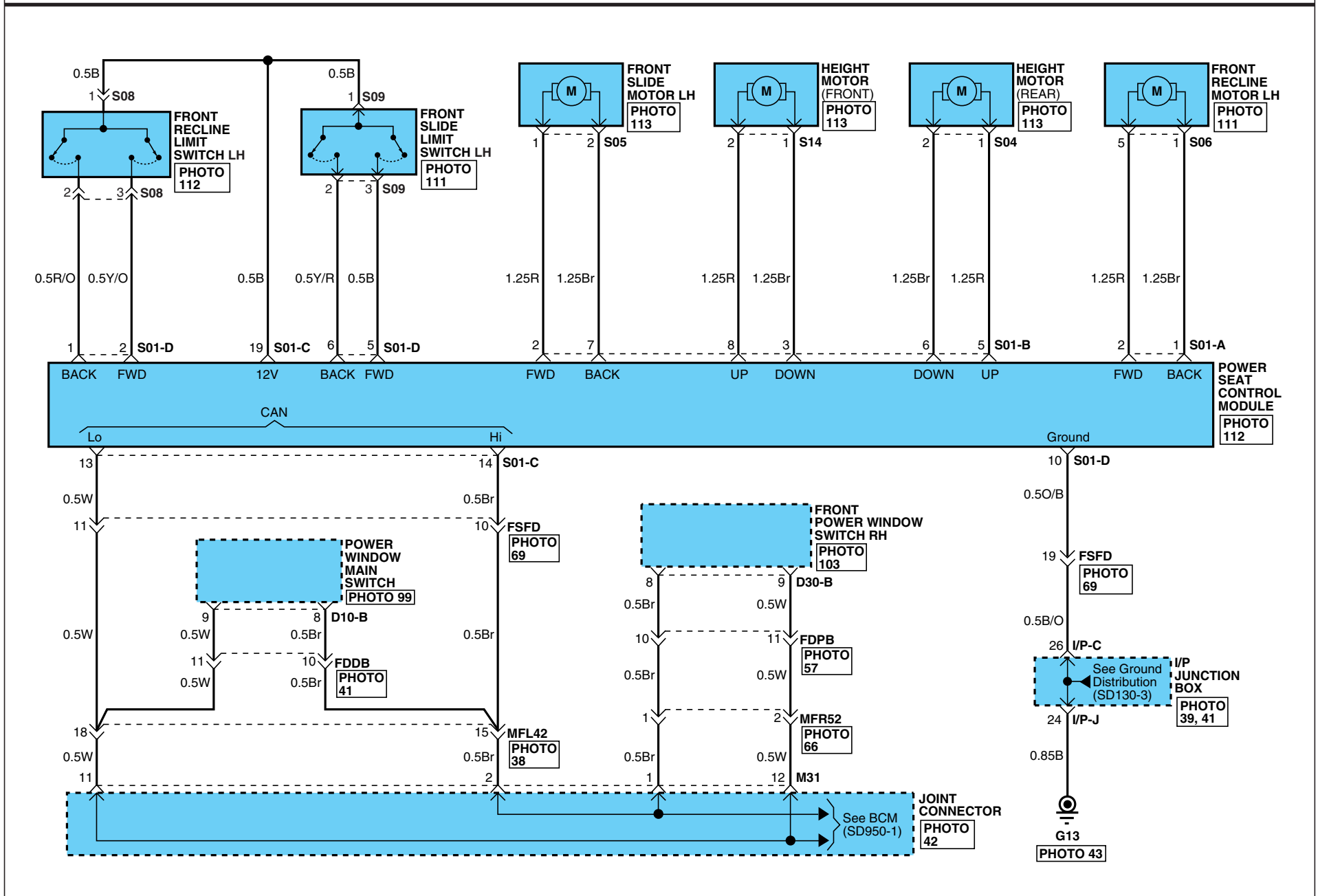

SD880-2



DRIVER POWER SEAT

DRIVER POWER SEAT (W/O IMS) (3)

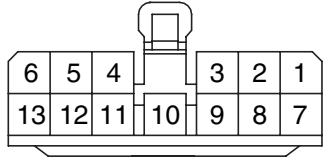
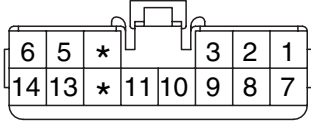
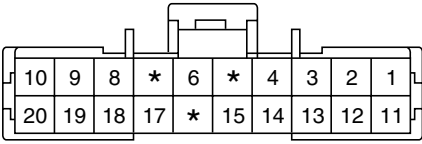
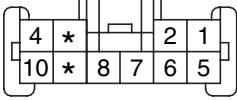
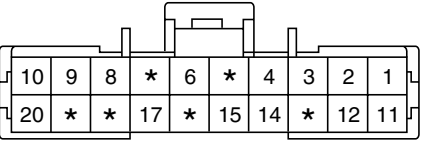
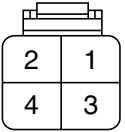
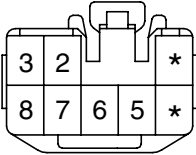
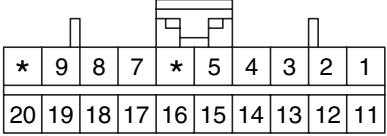
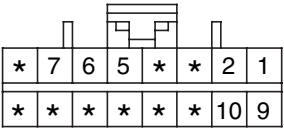
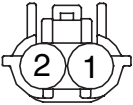
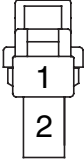
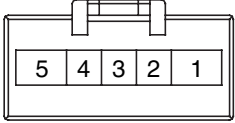
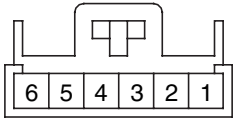
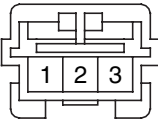
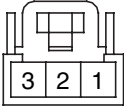
SD880-3

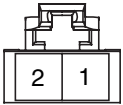
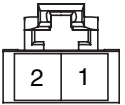
<p>D05</p>  <p>AMP_MIC_13F_W</p>	<p>D10-A</p>  <p>KET_090II_14F_W</p>	<p>D10-B</p>  <p>KET_SP_20F_W</p>	<p>D16</p>  <p>KET_MG_610404</p>
<p>D30-B</p>  <p>KET_SP_20F_W</p>	<p>S01-A</p>  <p>AMP_250_04F</p>	<p>S01-B</p>  <p>KET_SDLII_08F</p>	<p>S01-C</p>  <p>AMP_040MII_20F</p>
<p>S01-D</p>  <p>AMP_040MII_16F</p>	<p>S04</p>  <p>KET_SWP_02F_B</p>	<p>S05</p>  <p>KET_250DL_02F</p>	<p>S06</p>  <p>AMP_MQS_05F_B</p>
<p>S07</p>  <p>AMP_070_06F_W</p>	<p>S08</p>  <p>AMP_070_03M</p>	<p>S09</p>  <p>AMP_070_03F</p>	<p>S14</p>  <p>KET_SWP_02F_B</p>
<p>S15</p>  <p>PKD_MP_480_02F</p>	<p>S16</p>  <p>PKD_MP_480_02F</p>	<p>BLANK</p>	<p>BLANK</p>

DRIVER POWER SEAT

DRIVER POWER SEAT (W/O IMS) (4)

SD880-4

MEMO

PASSENGER POWER SEAT (1)

SD881-1

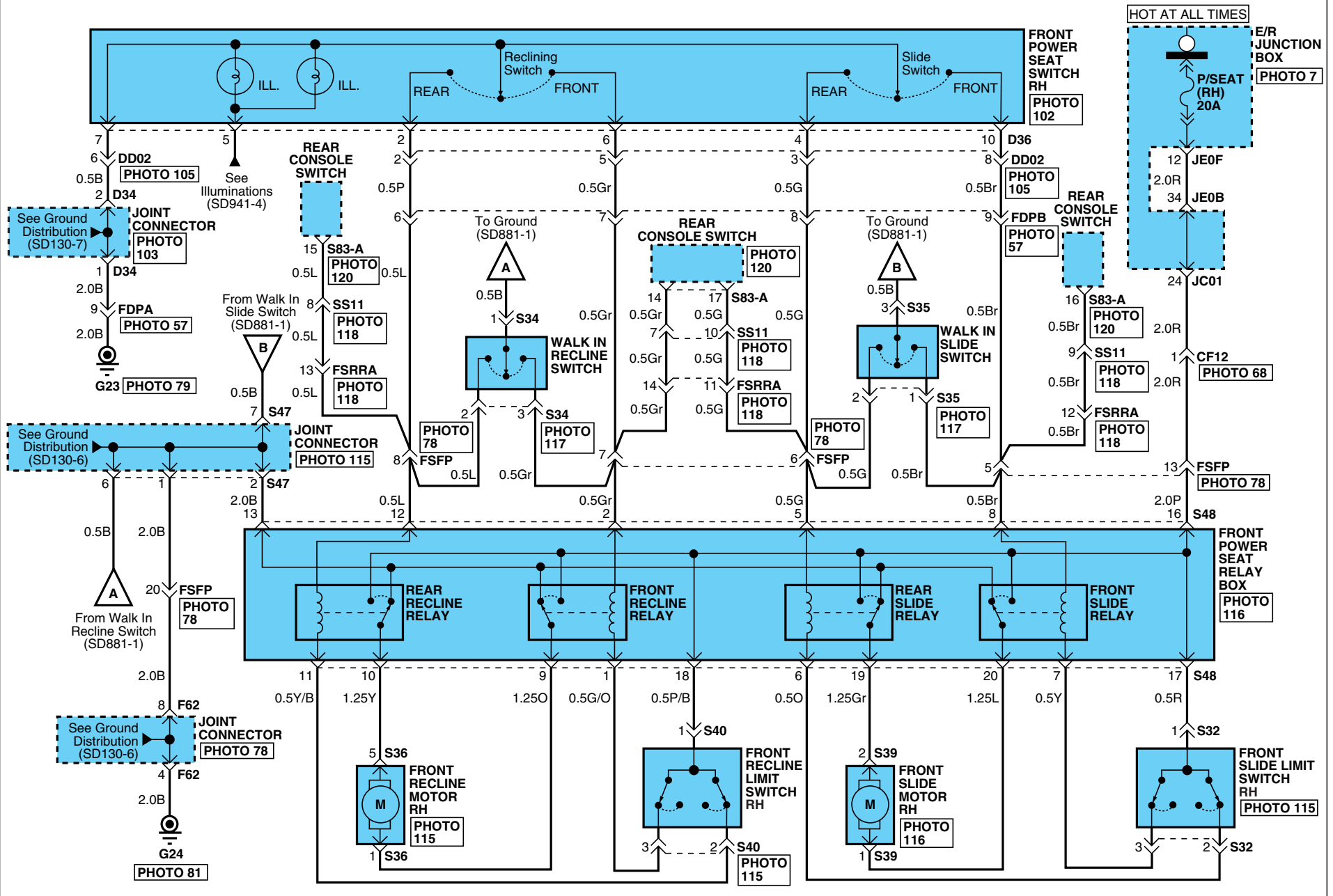

PASSENGER POWER SEAT

PASSENGER POWER SEAT (2) SD881-2

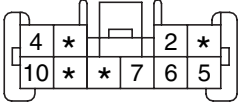
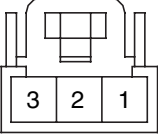
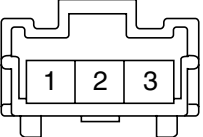
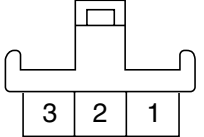
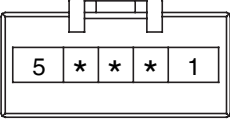
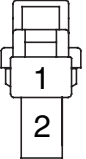
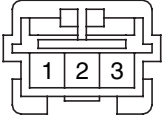
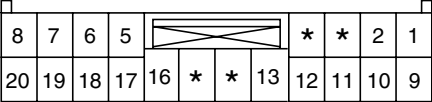
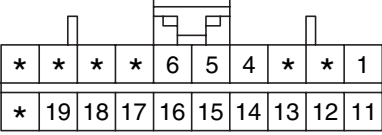
<p>D36</p>  <p style="text-align: right; font-size: small;">KET_MG_610404</p>	<p>S32</p>  <p style="text-align: right; font-size: small;">AMP_070_03F</p>	<p>S34</p>  <p style="text-align: right; font-size: small;">KET_SDL_03M</p>	<p>S35</p>  <p style="text-align: right; font-size: small;">KET_SDL_03F</p>
<p>S36</p>  <p style="text-align: right; font-size: small;">AMP_MQS_05F_B</p>	<p>S39</p>  <p style="text-align: right; font-size: small;">KET_250DL_02F</p>	<p>S40</p>  <p style="text-align: right; font-size: small;">AMP_070_03M</p>	<p>S48</p>  <p style="text-align: right; font-size: small;">AMP_09250_20F</p>
<p>S83-A</p>  <p style="text-align: right; font-size: small;">AMP_040MKII_20F</p>	<p>BLANK</p>	<p>BLANK</p>	<p>BLANK</p>

REAR POWER SEAT

REAR POWER SEAT (2)

SD882-2

F30

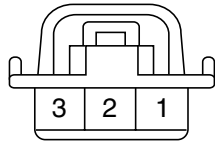

KET_62C_03F_W_DR

F67

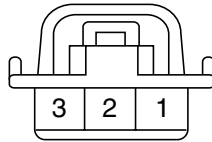

KET_62C_03F_W_DR

S64

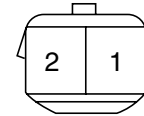

KET_090_02F

S65

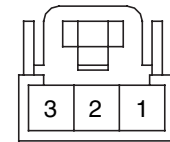

AMP_070_03F

S74

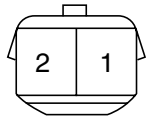

KET_090_02F

S75

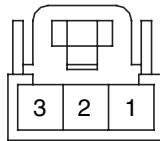

AMP_070_03F

S77

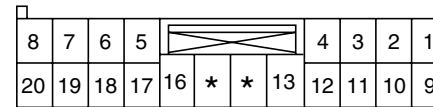

AMP_09250_20F

S83-A

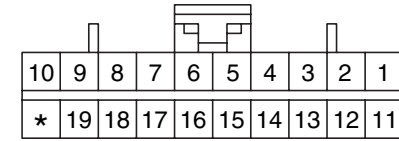

AMP_040MKII_20F

S83-B

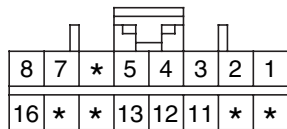

AMP_040MKII_16F

BLANK

BLANK

BLANK

ADJUSTABLE SEAT WARMER SYSTEM

ADJUSTABLE SEAT WARMER SYSTEM (2)

SD885-2

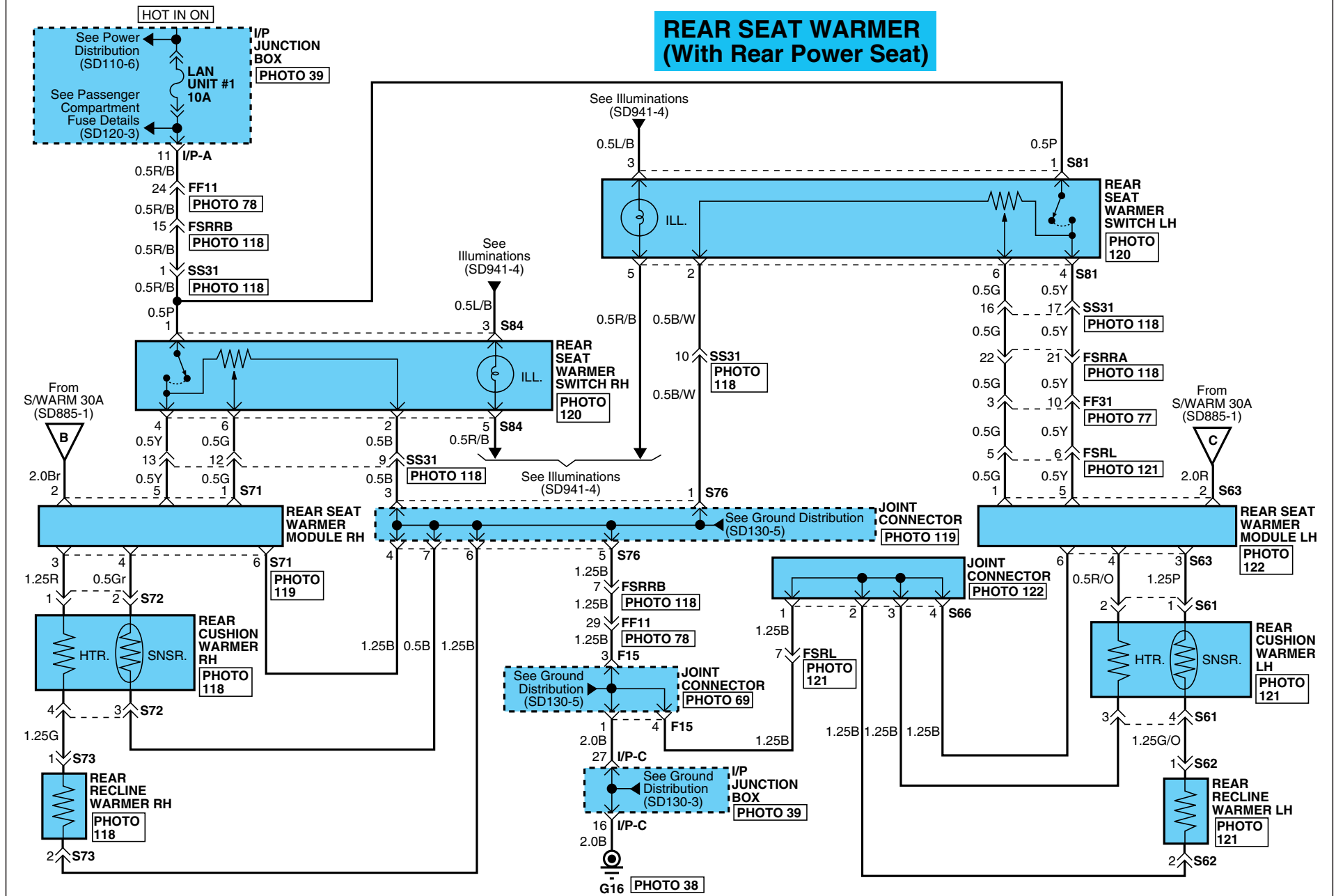

ADJUSTABLE SEAT WARMER SYSTEM

ADJUSTABLE SEAT WARMER SYSTEM (3)

SD885-3

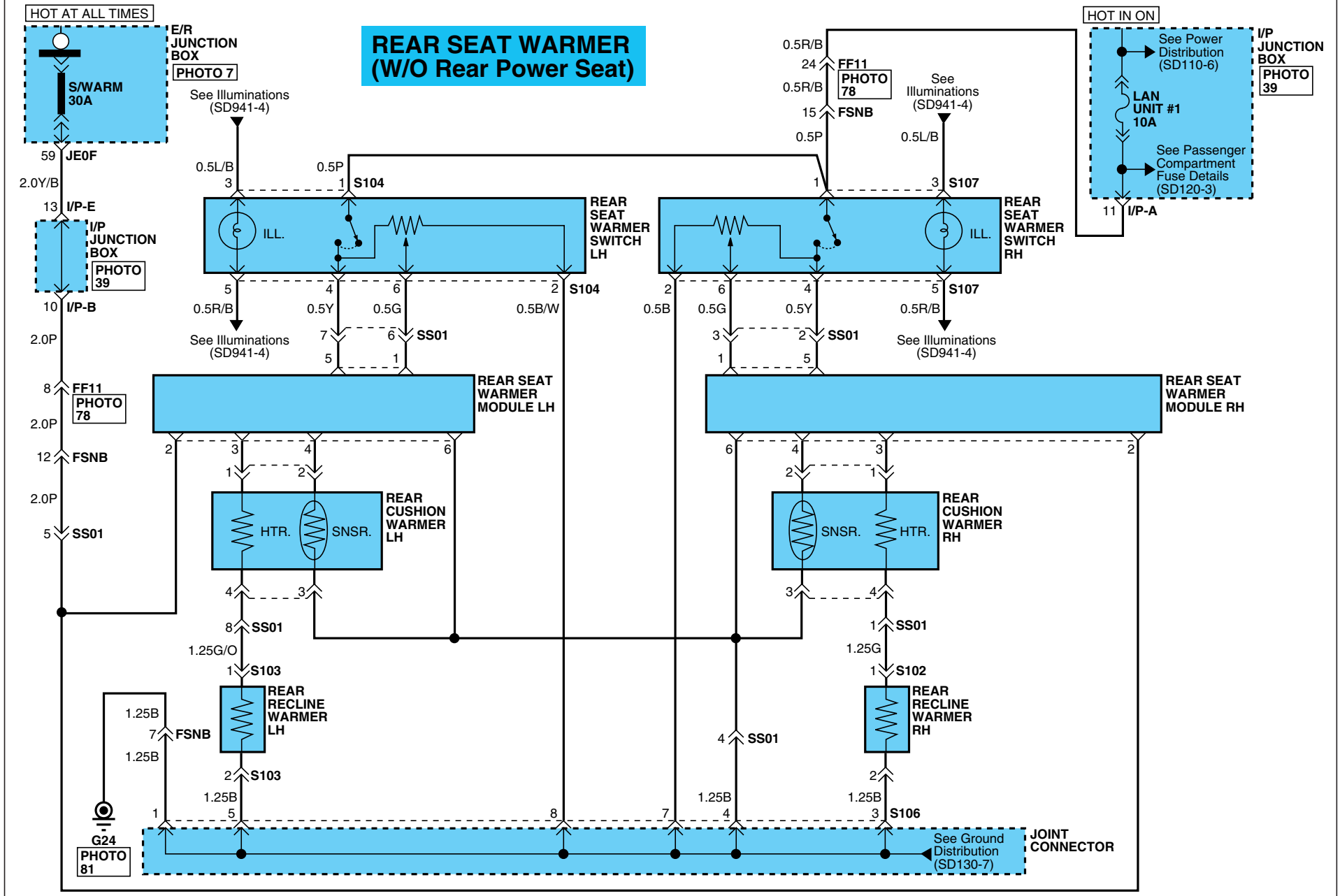

ADJUSTABLE SEAT WARMER SYSTEM

ADJUSTABLE SEAT WARMER SYSTEM (4)

SD885-4

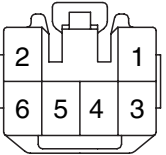
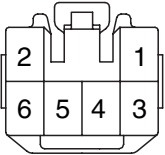
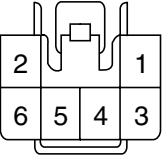
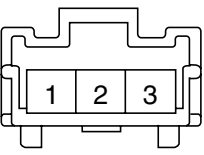
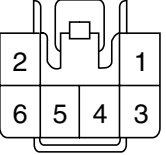
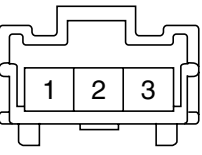
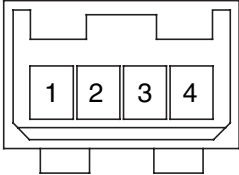
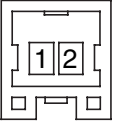
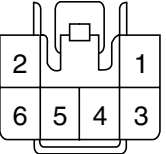
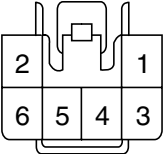
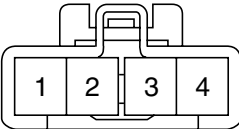
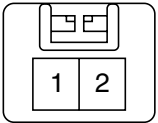
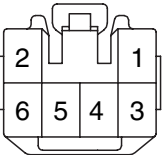
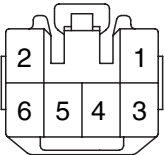
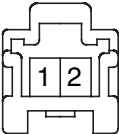
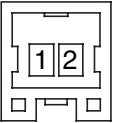
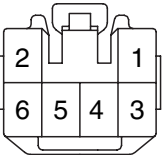
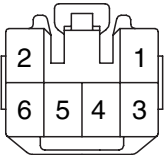
<p>M20-1</p>  <p>KET_090II_06F_Y</p>	<p>M20-2</p>  <p>KET_090II_06F_B</p>	<p>S02</p>  <p>KET090_06F</p>	<p>S03</p>  <p>KET_SDL_03M</p>
<p>S31</p>  <p>KET_090_06F</p>	<p>S33</p>  <p>KET_SDL_03M</p>	<p>S61</p>  <p>AMP_090III_04M_B</p>	<p>S62</p>  <p>AMP_090III_02M_B</p>
<p>S63</p>  <p>KET_090_06F</p>	<p>S71</p>  <p>KET_090_06F</p>	<p>S72</p>  <p>KET_SDL_04M</p>	<p>S73</p>  <p>KET_SDL_02M</p>
<p>S81</p>  <p>KET_090II_06F_B</p>	<p>S84</p>  <p>KET_090II_06F_W</p>	<p>S102</p>  <p>KET_SDL_02M_W</p>	<p>S103</p>  <p>AMP_090III_02M_B</p>
<p>S104</p>  <p>KET_090II_06F_B</p>	<p>S107</p>  <p>KET_090II_06F_W</p>	<p>BLANK</p>	<p>BLANK</p>

CLIMATE CONTROL SEAT (1)

SD886-1

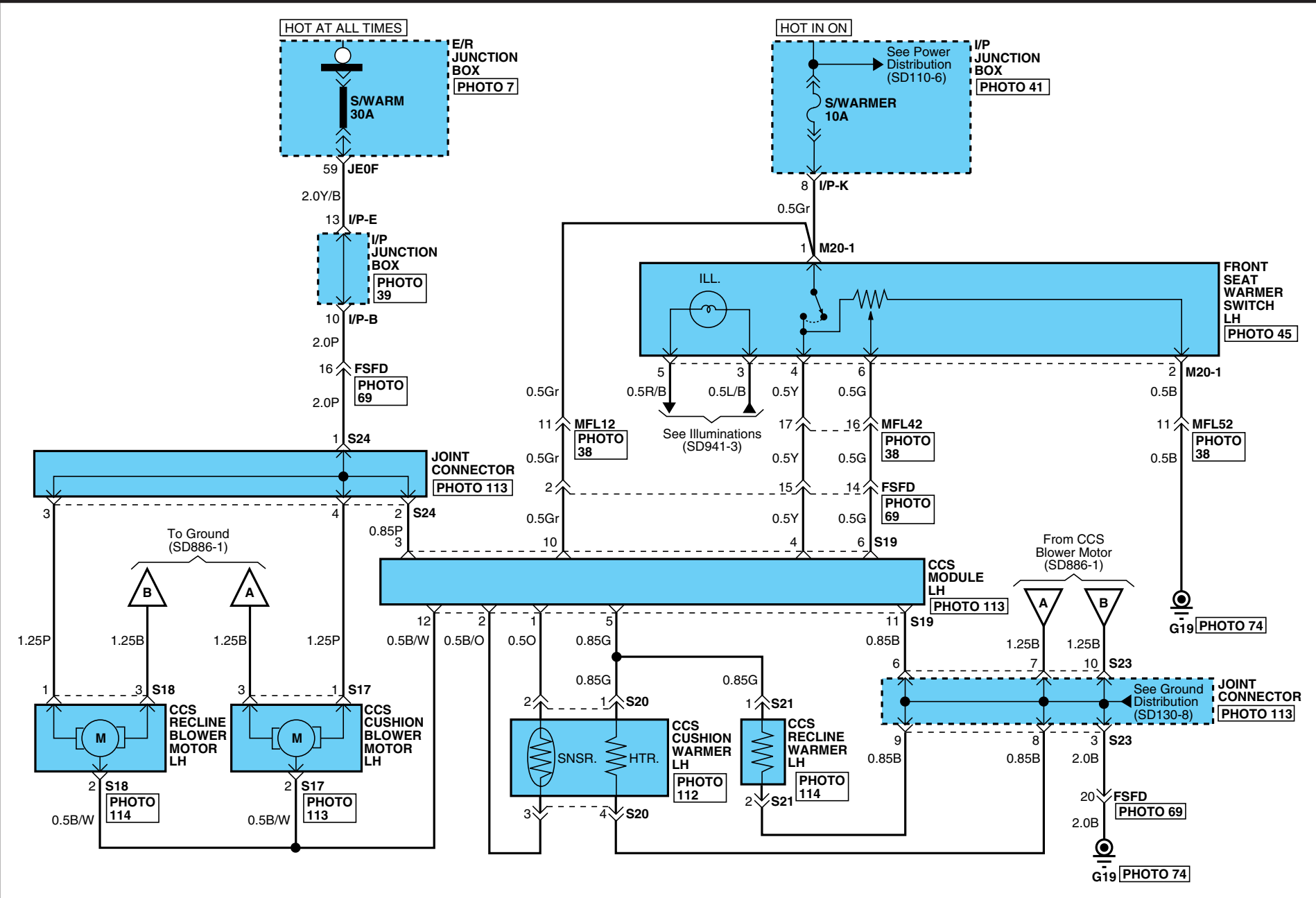

CLIMATE CONTROL SEAT

CLIMATE CONTROL SEAT (2)

SD886-2

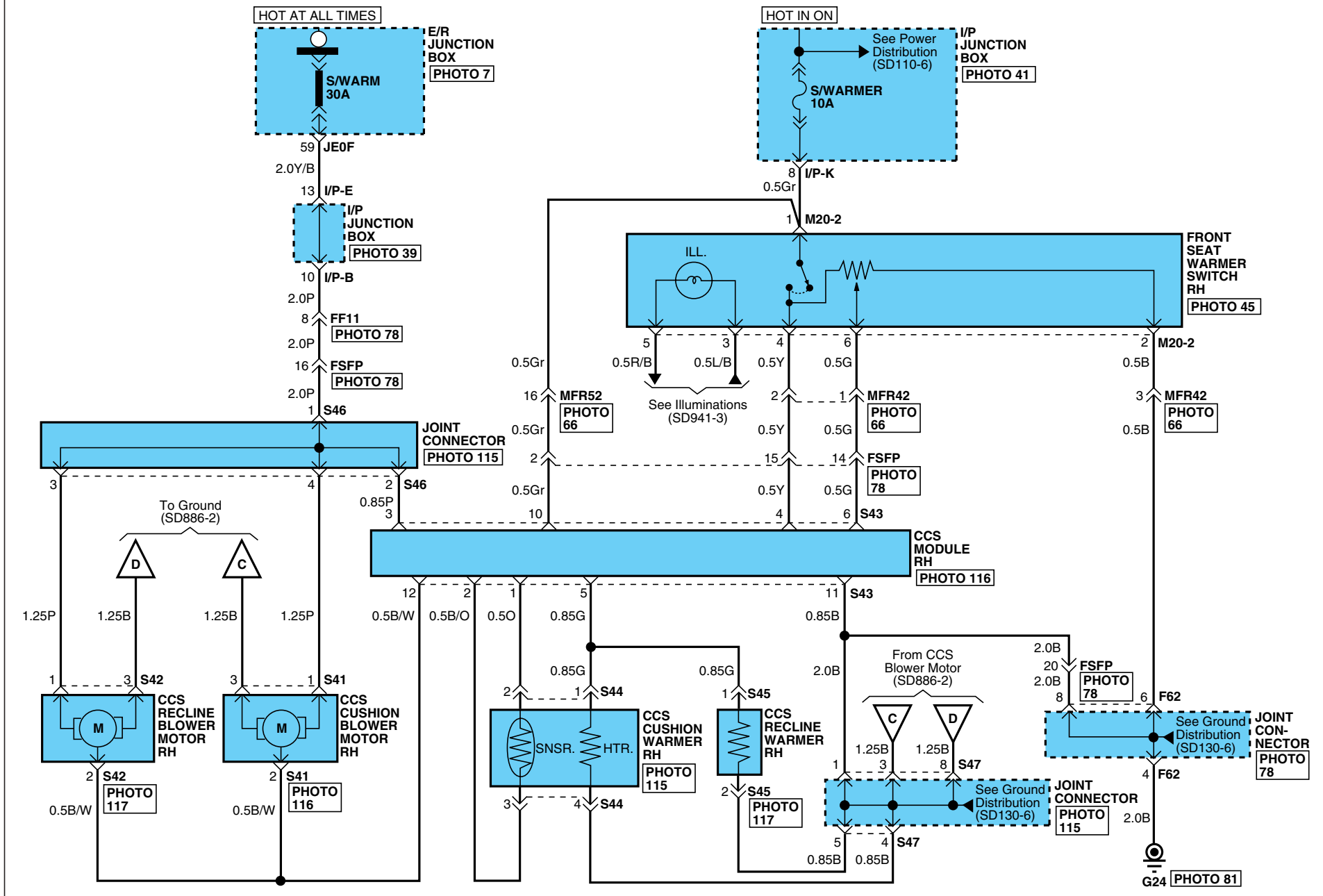

CLIMATE CONTROL SEAT

CLIMATE CONTROL SEAT (3)

SD886-3

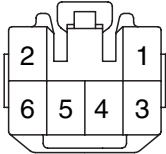
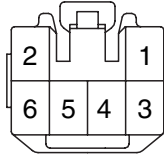
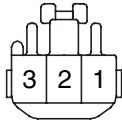
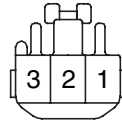
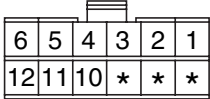
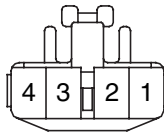
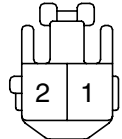
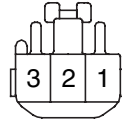
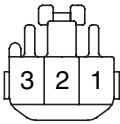
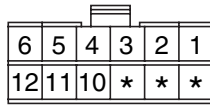
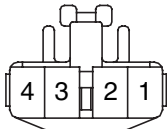
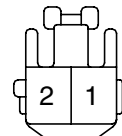
<p>M20-1</p>  <p>KET_090II_06F_Y</p>	<p>M20-2</p>  <p>KET_090II_06F_B</p>	<p>S17</p>  <p>KET_090II_03F</p>	<p>S18</p>  <p>KET_090II_03F</p>
<p>S19</p>  <p>MLX_FIT_12F</p>	<p>S20</p>  <p>KET_090II_04F</p>	<p>S21</p>  <p>KET_090II_02F_T</p>	<p>S41</p>  <p>KET_090II_03F</p>
<p>S42</p>  <p>KET_090II_03F</p>	<p>S43</p>  <p>MLX_FIT_12F</p>	<p>S44</p>  <p>KET_090II_04F</p>	<p>S45</p>  <p>KET_090II_02F_T</p>
Empty space for additional diagrams			

CLIMATE CONTROL SEAT

CLIMATE CONTROL SEAT (4)

SD886-4

MEMO

REAR REMOTE CONTROL (1)

SD888-1

With Rear Power Seat

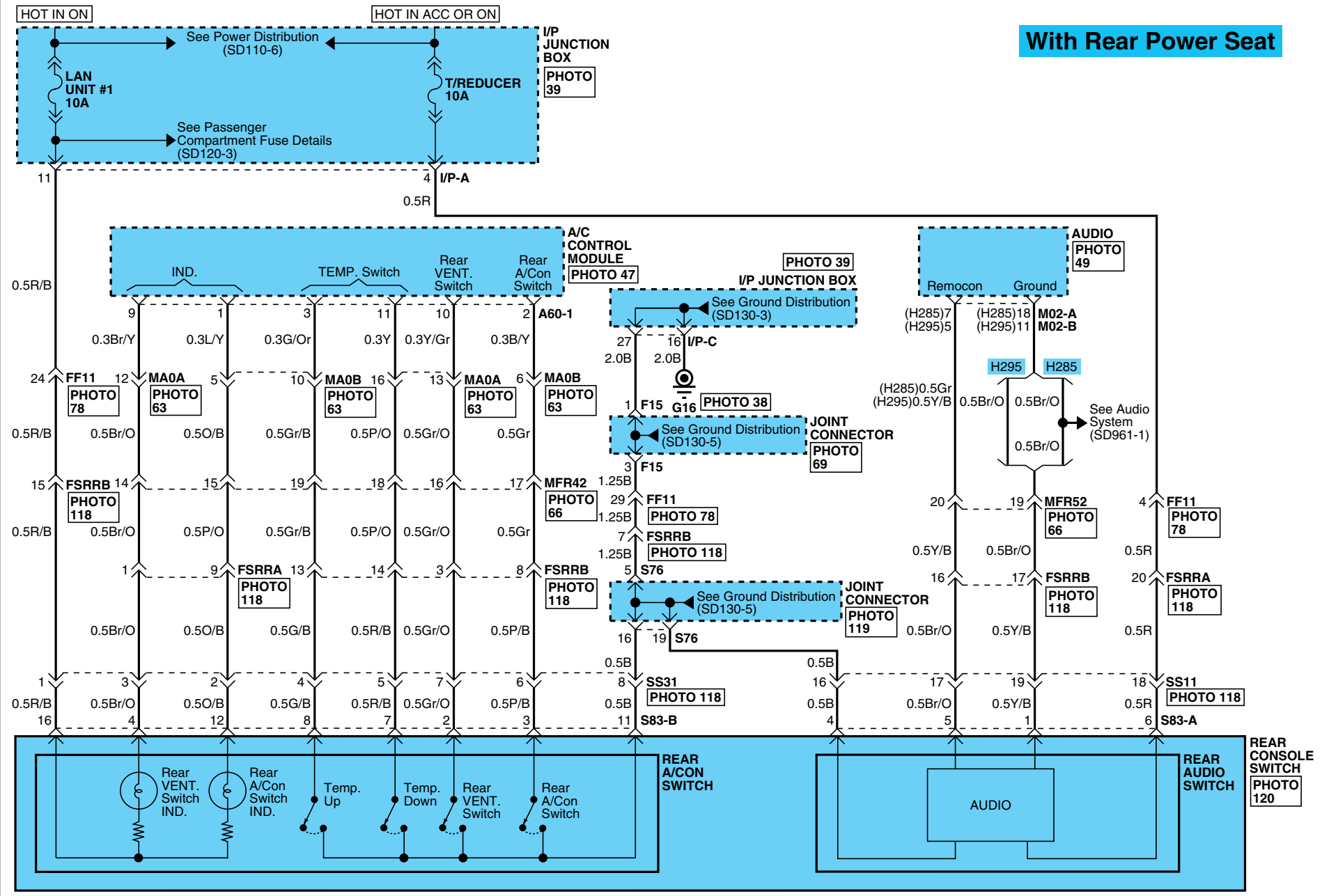

REAR REMOTE CONTROL

REAR REMOTE CONTROL (2)

SD888-2

With Rear Power Seat

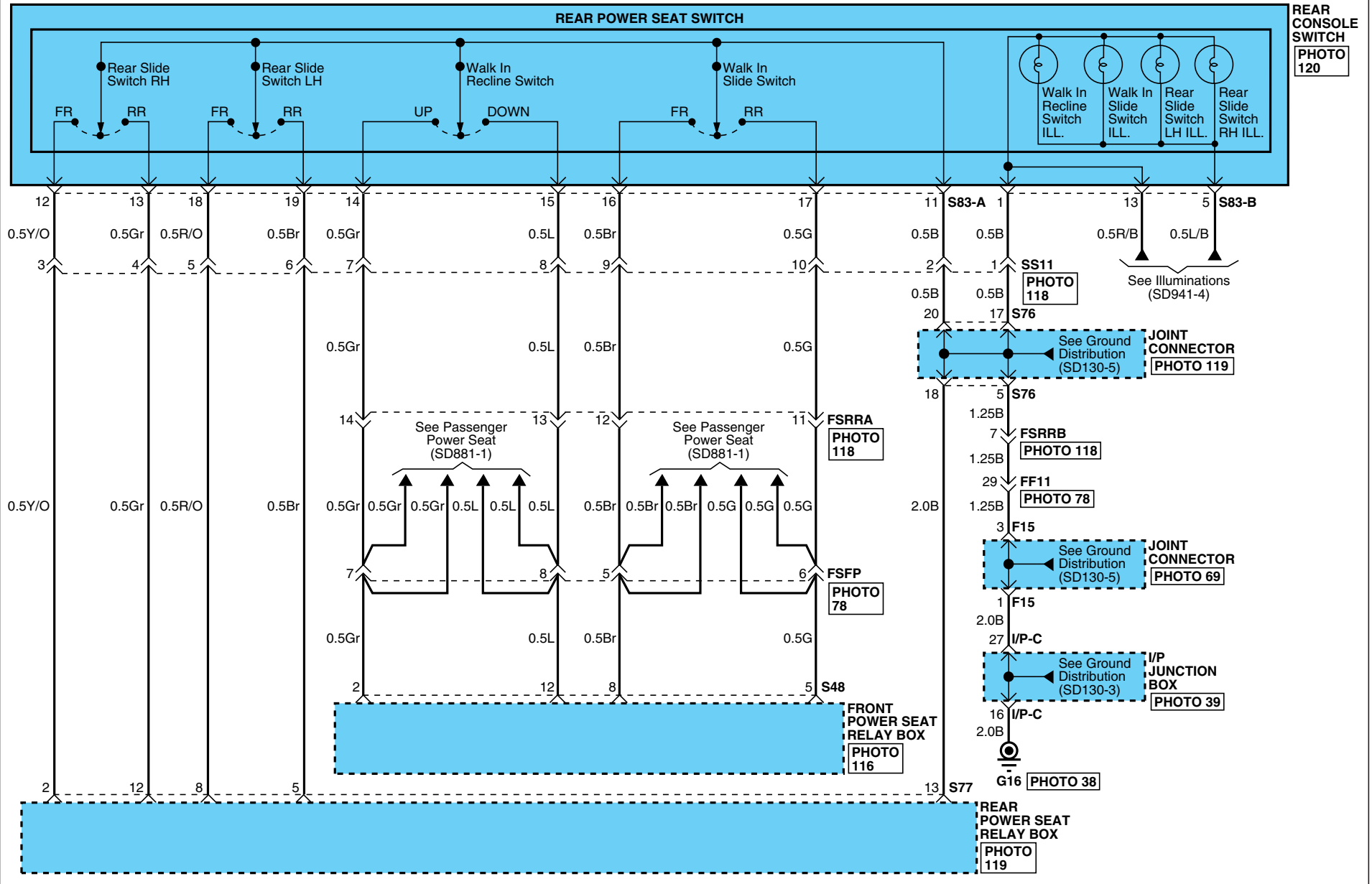

REAR REMOTE CONTROL

REAR REMOTE CONTROL (3)

SD888-3

W/O Rear Power Seat

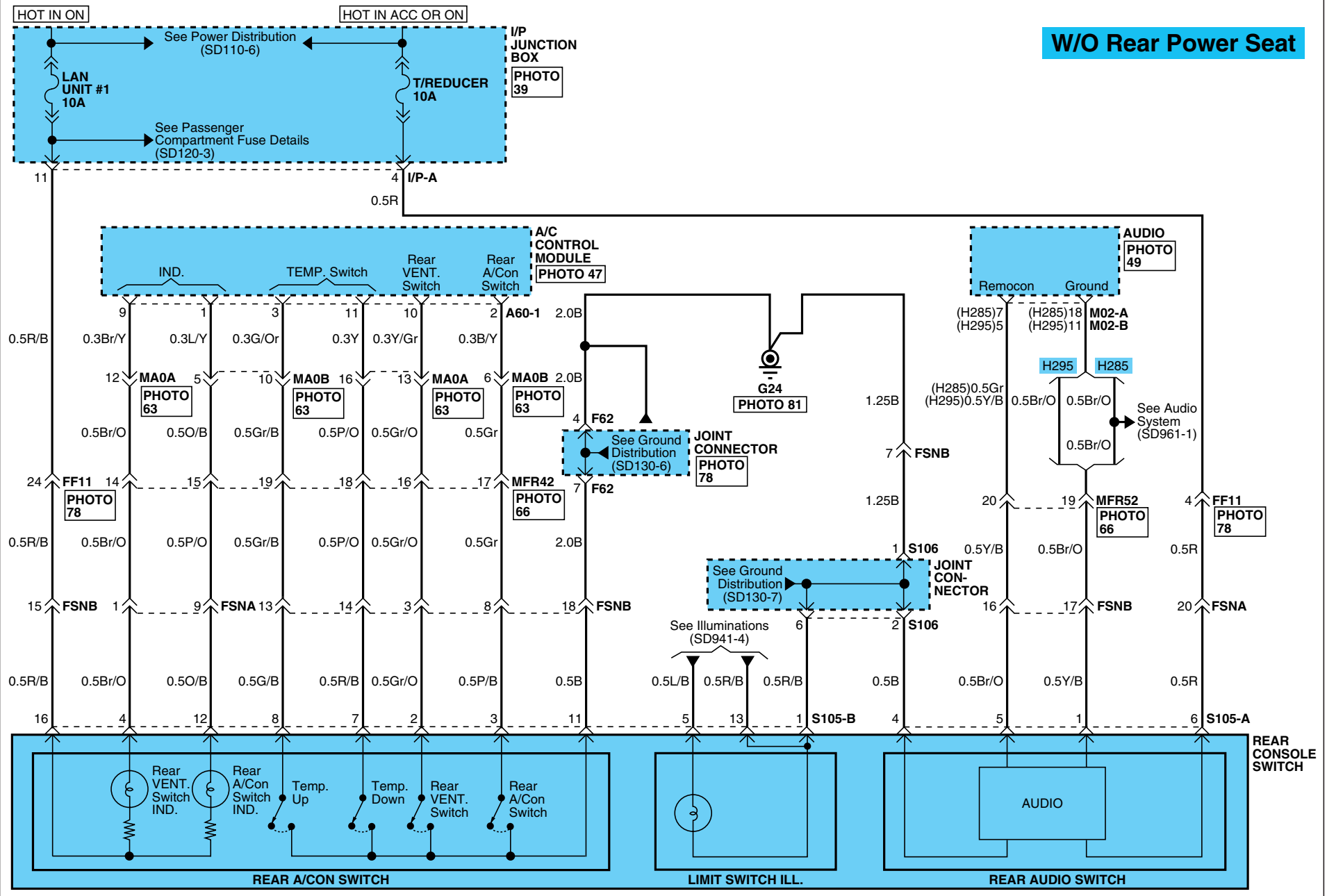

REAR REMOTE CONTROL

REAR REMOTE CONTROL (4)

SD888-4

A60-1

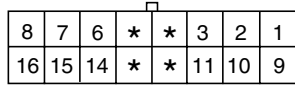

CR16F024

M02-A

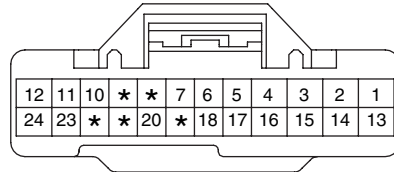

KET_0409_24F_W

M02-B

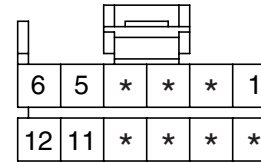

AMP_040M1_12F_B

S48

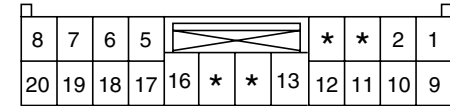

AMP_09250_20F

S77

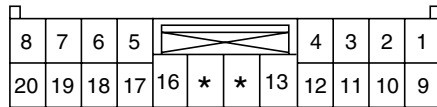

AMP_09250_20F

S83-A

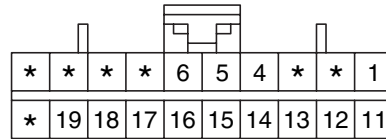

AMP_040MKII_20F

S83-B

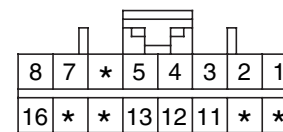

AMP_040MKII_16F

S105-A

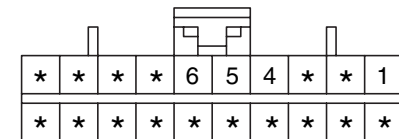

AMP_040MKII_20F

S105-B

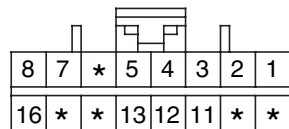

AMP_040MKII_16F

BLANK

BLANK

BLANK

HEAD LAMPS (1)

SD921-1

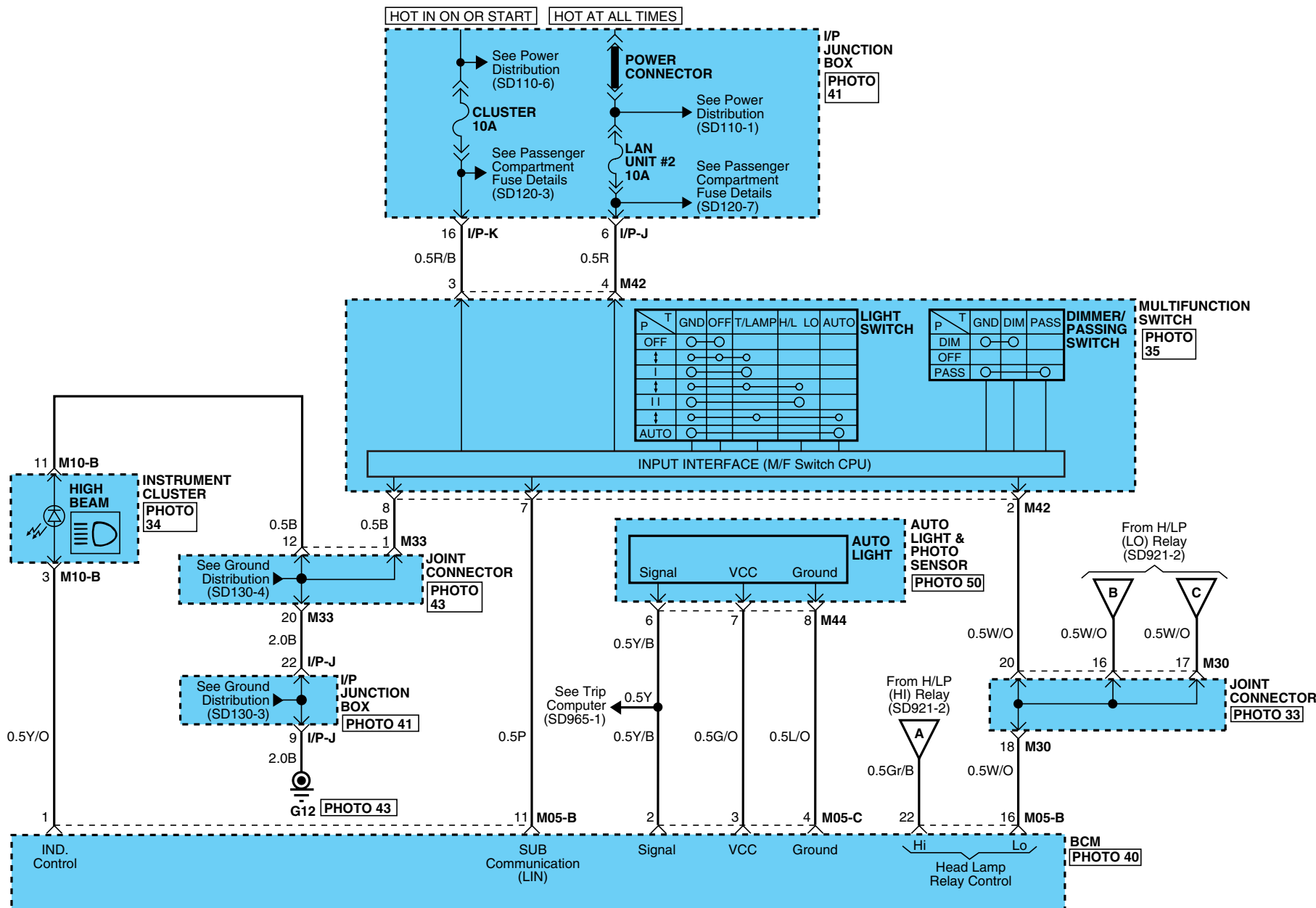

HEAD LAMPS

HEAD LAMPS (3)

SD921-3

E16



KUM_NMWP_06F_B

E17

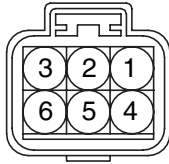

KUM_NMWP_06F_B

E18

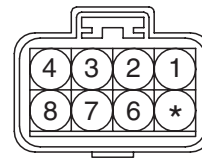

KUM_NMWP_08F_B

E19

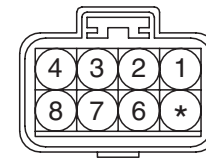

KUM_NMWP_08F_B

E39

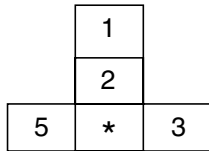

CR05F011

M05-B

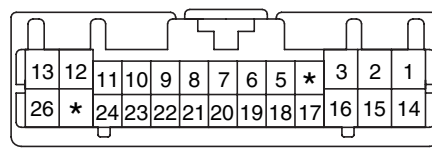

KET_0407_26F_W

M05-C

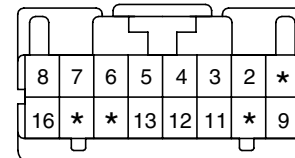

KET_0407_16F_W

M10-B

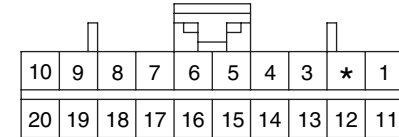

AMP_040M2_20F_B

M42

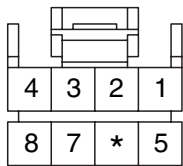

AMP_040M1_08F_B

M44

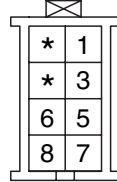

KET_030_08F_GR

BLANK

BLANK

HEAD LAMPS

HEAD LAMPS (4)

SD921-4

MEMO

HEAD LAMP LEVELING DEVICE (1)

SD922-1

Auto HLLD

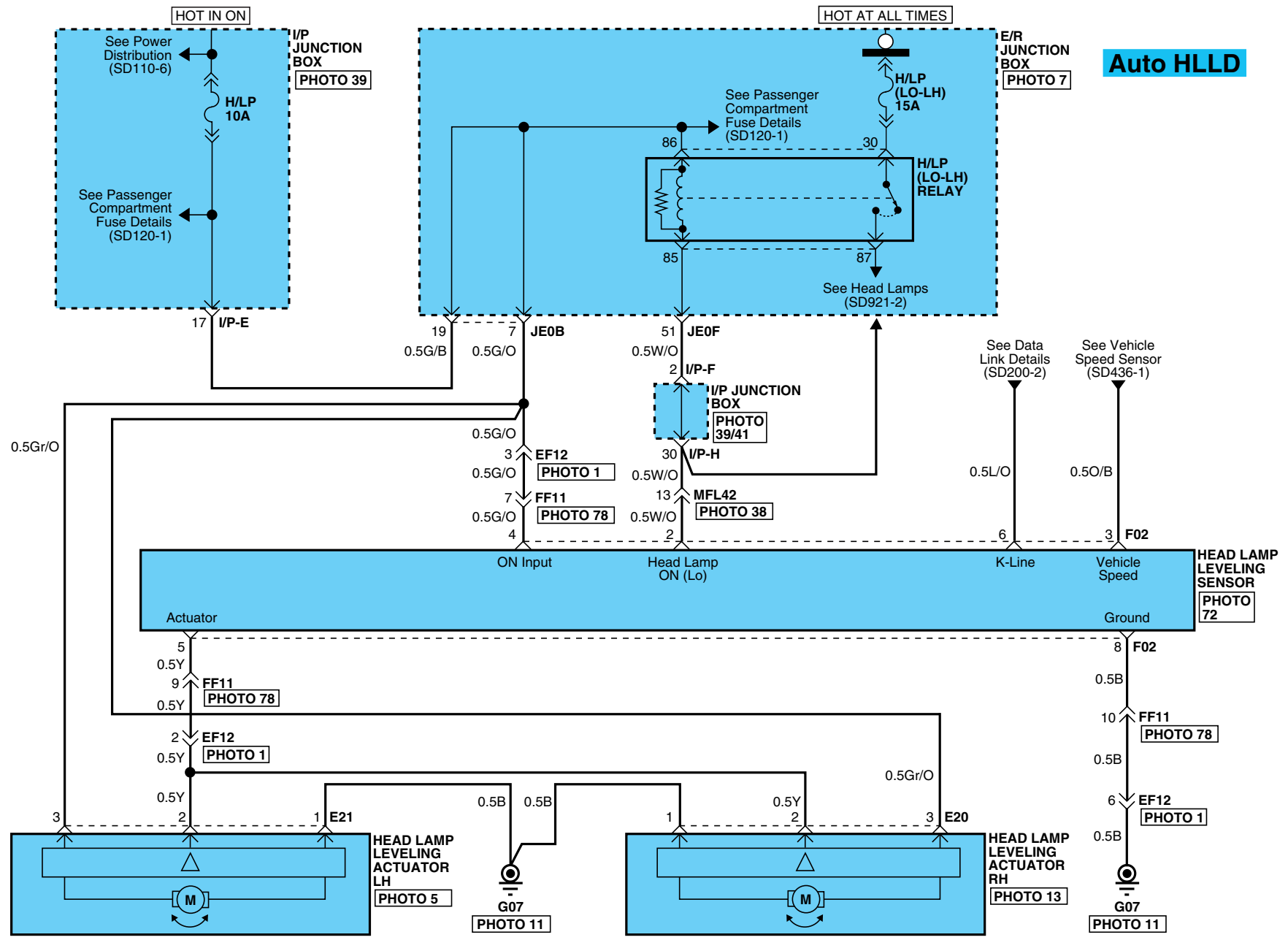

HEAD LAMP LEVELING DEVICE

HEAD LAMP LEVELING DEVICE (2)

SD922-2

Manual HLLD

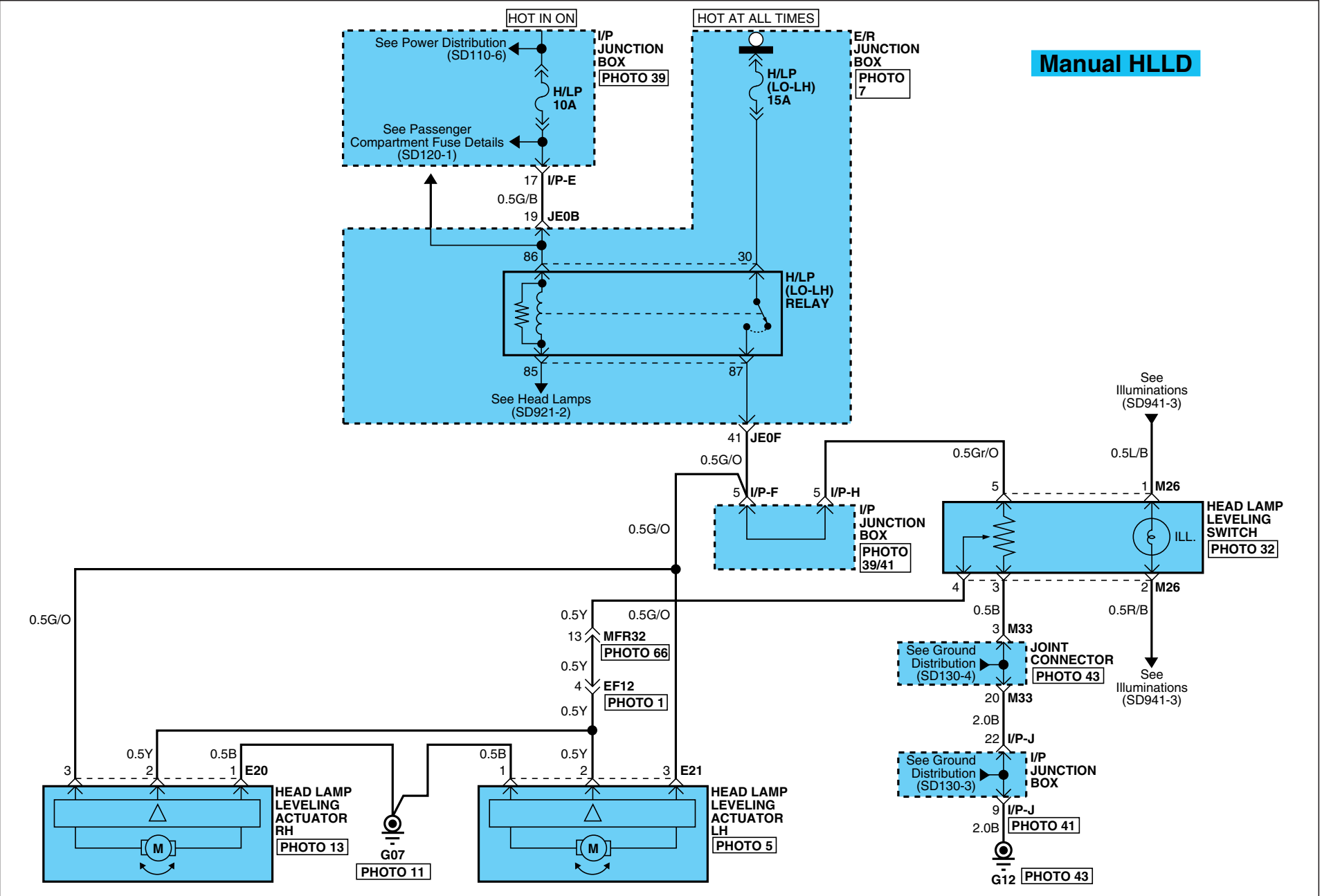

HEAD LAMP LEVELING DEVICE

HEAD LAMP LEVELING DEVICE (3)

SD922-3

E20

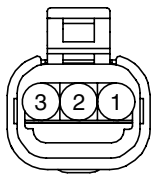

AMP_025WP_03F_B

E21

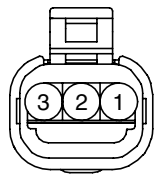

AMP_025WP_03F_B

F02

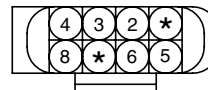

FEP_DEV_08F_B

M26

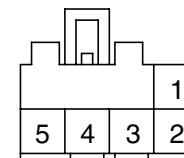

KUM_CDR_05F_B

HEAD LAMP LEVELING DEVICE

HEAD LAMP LEVELING DEVICE (4)

SD922-4

MEMO

HEAD LAMP WASHER

HEAD LAMP WASHER (2)

SD923-2

E25

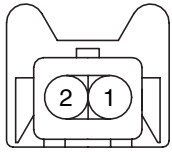

AMP_JPT_02F_B

E35

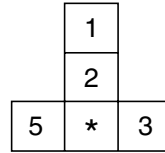

CR05F011

M05-B

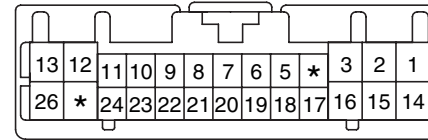

KET_0407_26F_W

M05-D

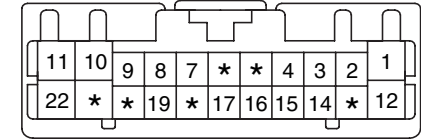

KET_0407_22F_W

M27

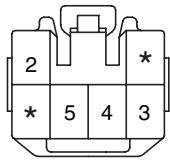

KET_090II_06F_L

BLANK

BLANK

BLANK

FOG LAMPS (1)

SD924-1

FRONT FOG LAMP

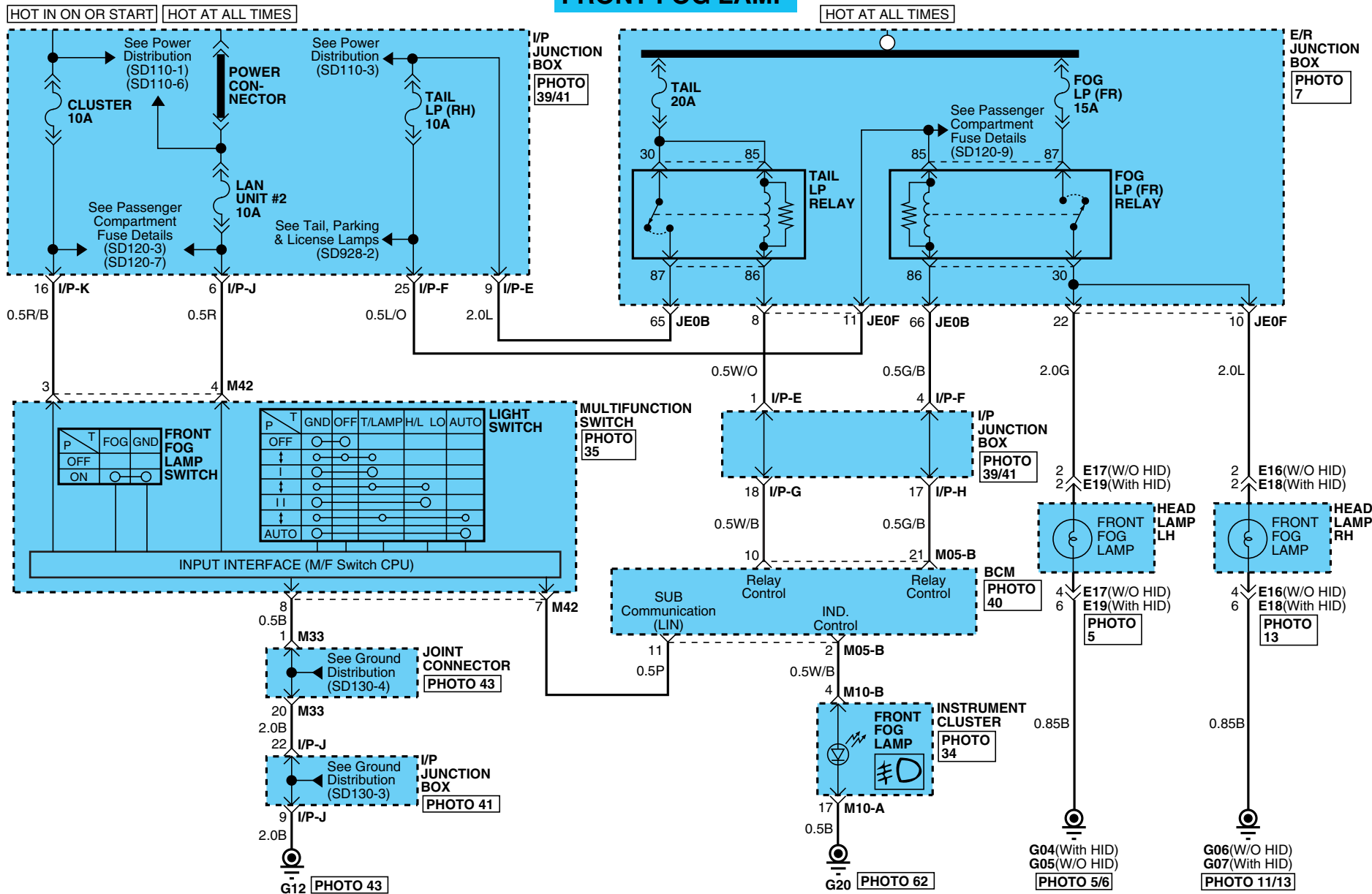

REAR FOG LAMP

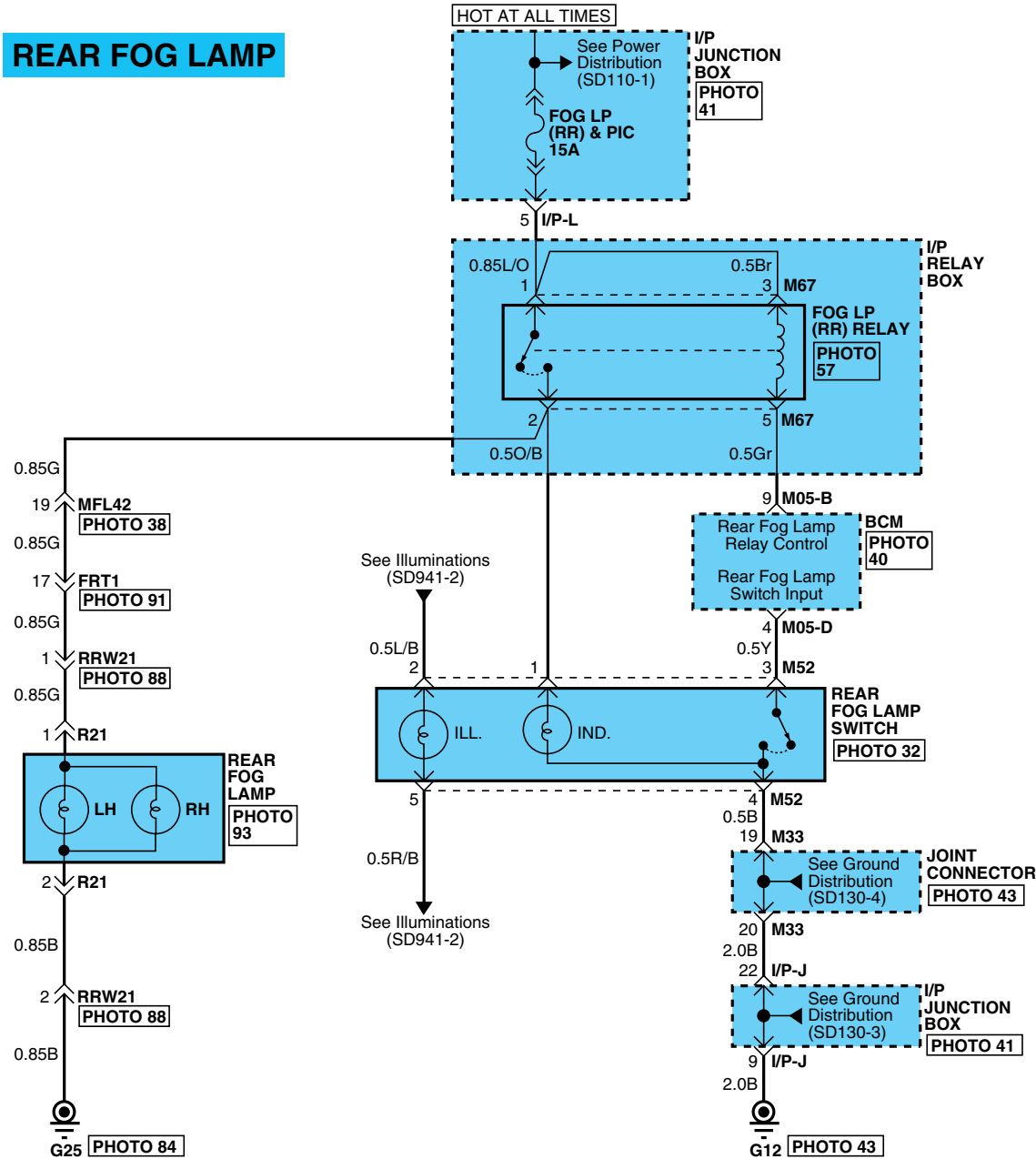

FOG LAMPS

FOG LAMPS (3)

SD924-3

E16

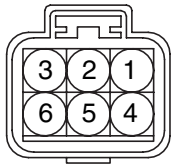

KUM_NMWP_06F_B

E17

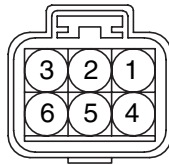

KUM_NMWP_06F_B

E18

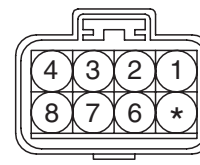

KUM_NMWP_08F_B

E19

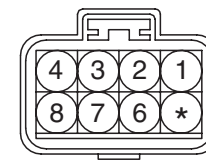

KUM_NMWP_08F_B

M05-B

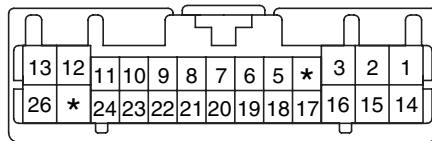

KET_0407_26F_W

M05-D

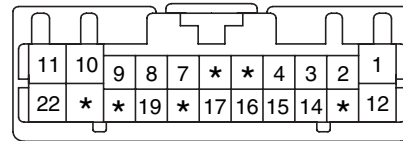

KET_0407_22F_W

M10-A

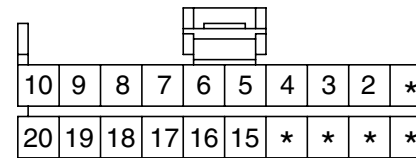

AMP_040M1_20F_B

M10-B

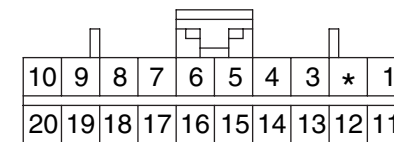

AMP_040M2_20F_B

M42

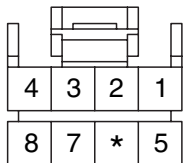

AMP_040M1_08F_B

M52

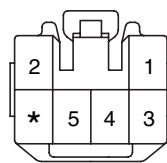

KET_090II_06F_G

M67

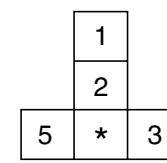

GH_IPNL_BOX_B

R21

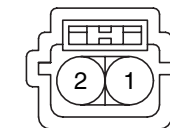

KUM_NDWP_02F_Gr

FOG LAMPS

FOG LAMPS (4)

SD924-4

MEMO

TURN & HAZARD LAMPS (1)

SD925-1

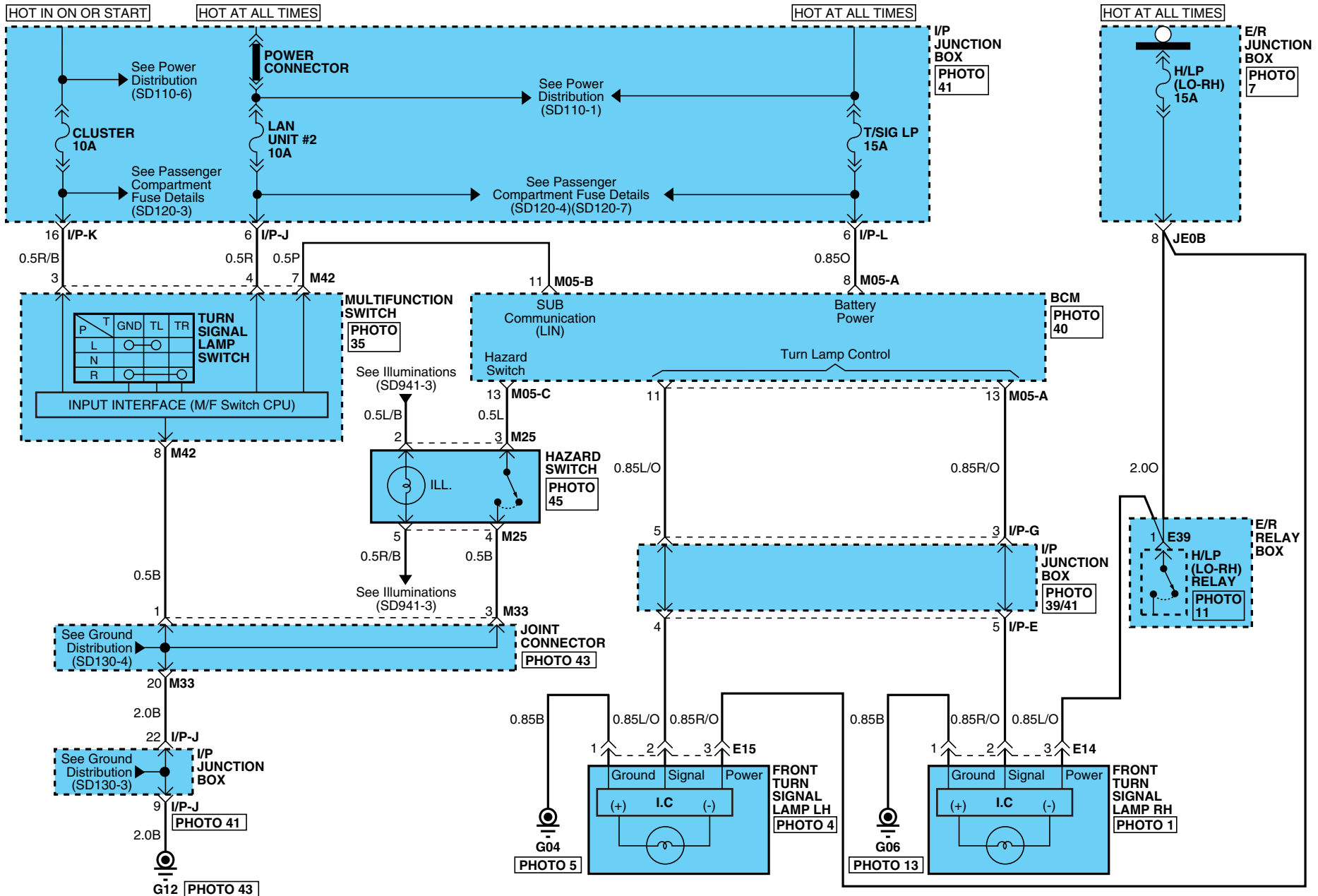

TURN & HAZARD LAMPS

TURN & HAZARD LAMPS (2)

SD925-2

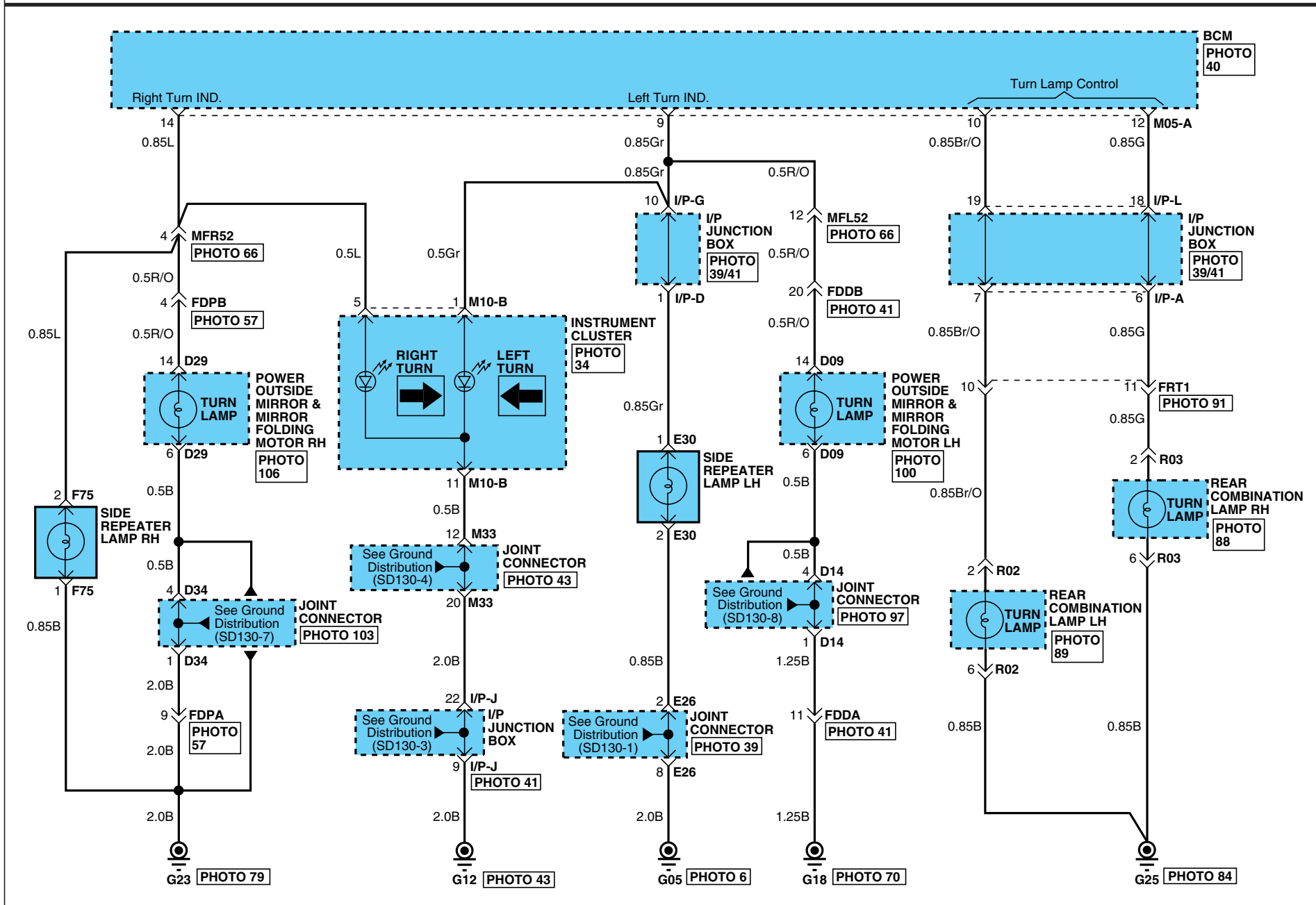

TURN & HAZARD LAMPS

TURN & HAZARD LAMPS (3)

SD925-3

D09

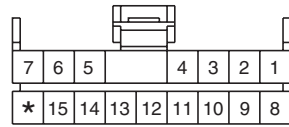

AMP_040III_16F_W

D29

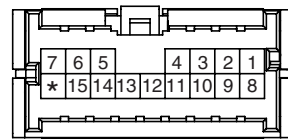

AMP_040III_16F_W

E14

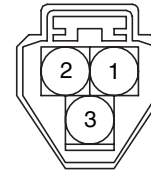

KUM_NMWP_03F_B

E15

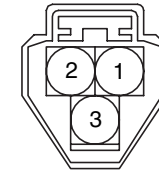

KUM_NMWP_03F_B

E30

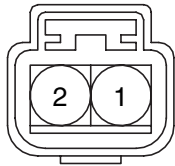

KUM_NMWP_02F_B

F75

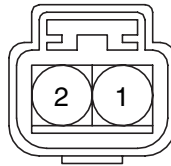

KUM_NMWP_02F_B

M05-A

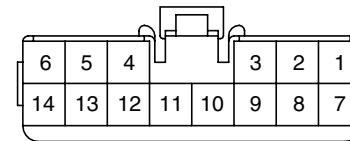

KET_090II_14F_W

M05-B

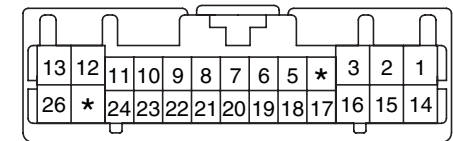

KET_0407_26F_W

M05-C

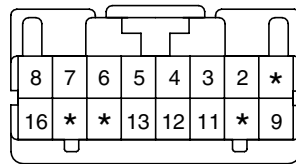

KET_0407_16F_W

M10-B

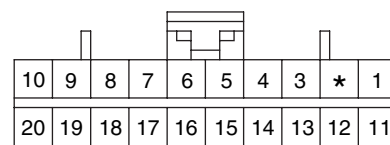

AMP_040M2_20F_B

M25

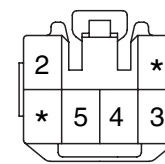

KET_090II_06F_W

M42

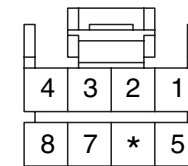

AMP_040M1_08F_B

R02

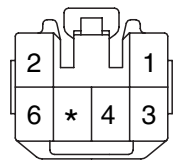

KET_090II_06F_W

R03

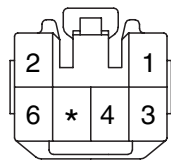

KET_090II_06F_W

BLANK

BLANK

TURN & HAZARD LAMPS

TURN & HAZARD LAMPS (4)

SD925-4

MEMO

BACK-UP LAMPS

BACK-UP LAMPS (2)

SD926-2

C109



KET_SSD_10F_B_A

F52-A

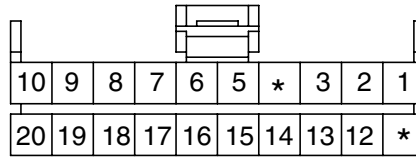

AMP_040M1_20F_B

C144-A

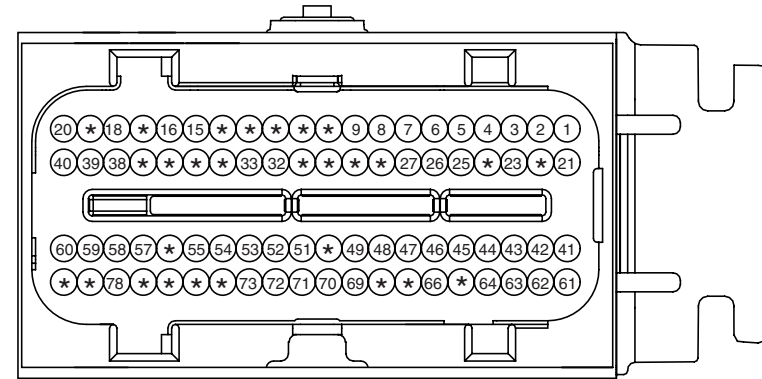

PKD_ECU_80F_GR_3

M10-B

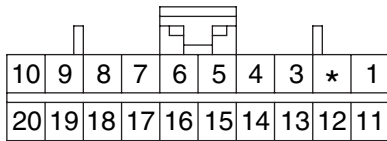

AMP_040M2_20F_B

M91

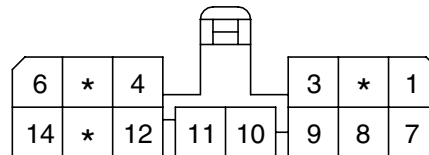

AMP_070_14F_W

R02

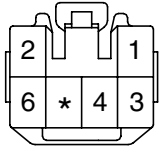

KET_090II_06F_W

R03

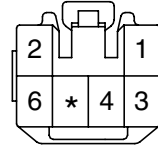

KET_090II_06F_W

R59

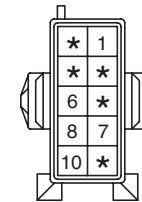

AMP_MQS_10F_B

S01-C

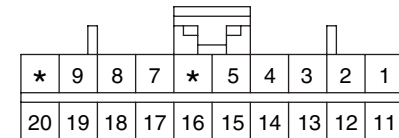

AMP_040MII_20F

STOP LAMPS

STOP LAMPS (2)

SD927-2

C144-A

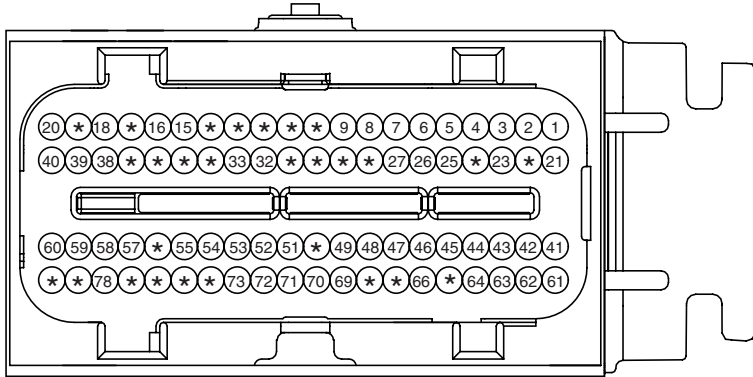

PKD_ECU_80F_GR_3

F23-B

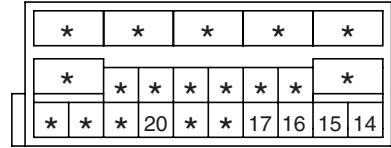

SIE_PIC_23F_G

F36

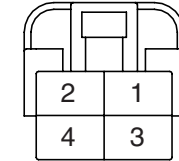

KET_250DL_04F_W

F51

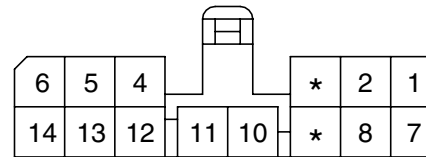

AMP_070_14F_W

F55-B

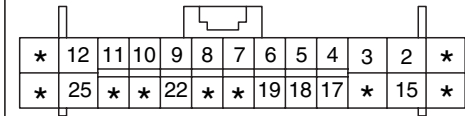

AMP_0407_26F_W_HD

F56

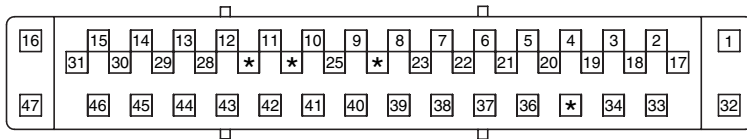

AMP_ESP_47F_L_UNIT

F83

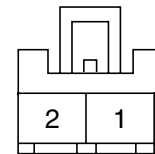

KUM_CDR_02F

M05-A

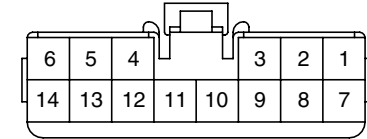

KET_090II_14F_W

M05-B

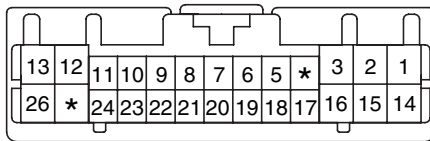

KET_0407_26F_W

M05-C

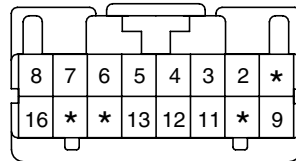

KET_0407_16F_W

M10-A

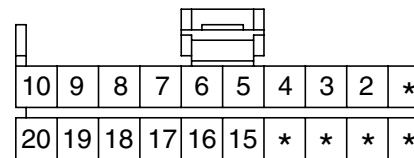

AMP_040M1_20F_B

M10-B

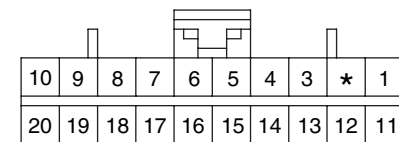

AMP_040M2_20F_B

M10-C

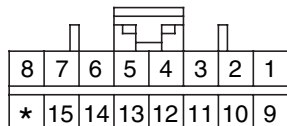

AMP_040M2_16F_B

R02

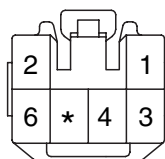

KET_090II_06F_W

R03

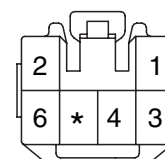

KET_090II_06F_W



BLANK

TAIL, PARKING & LICENSE LAMPS (1)

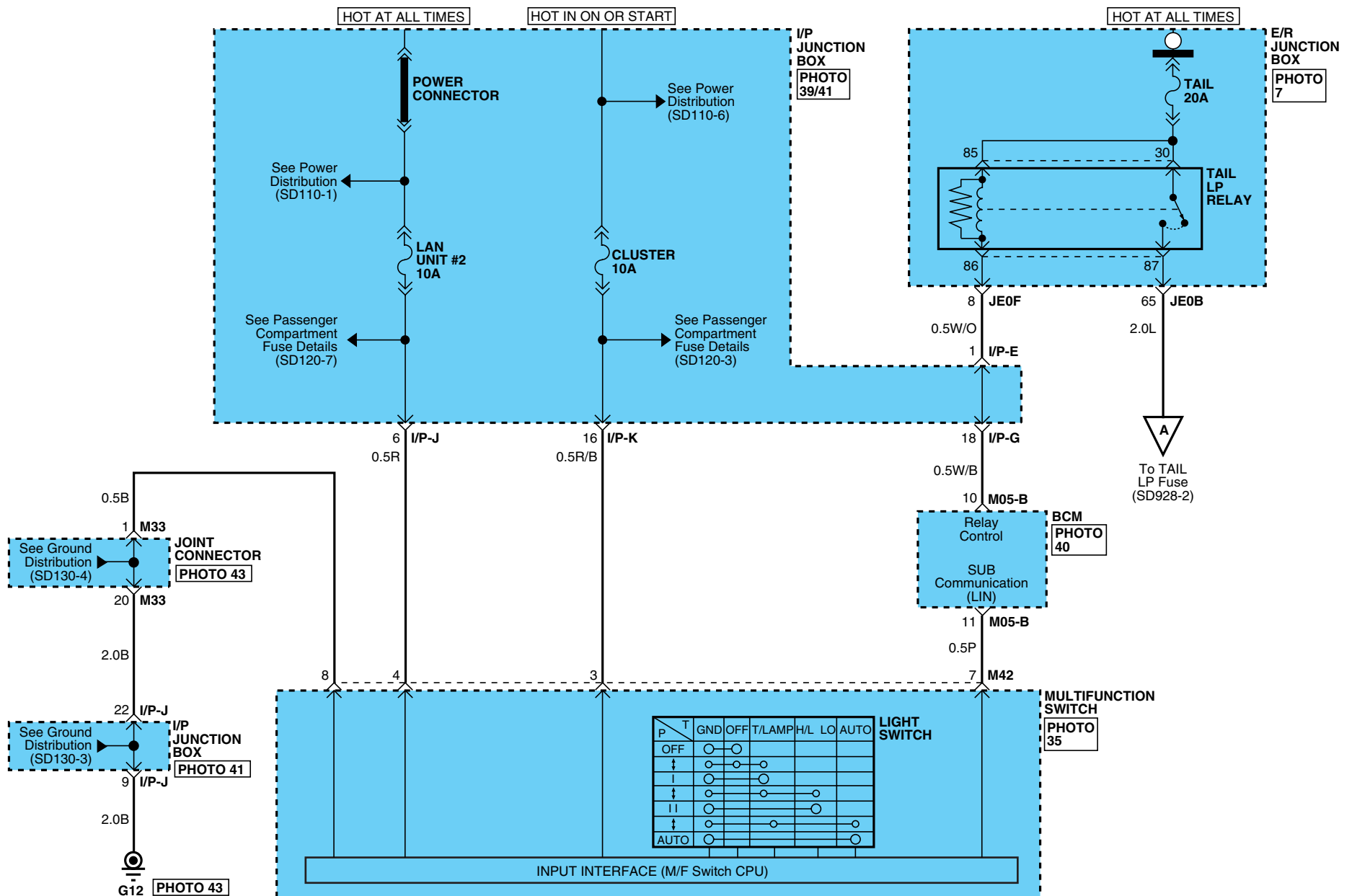
SD928-1

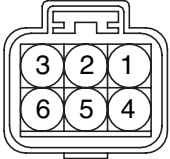

TAIL, PARKING & LICENSE LAMPS

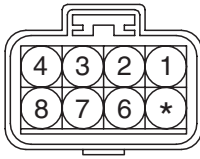
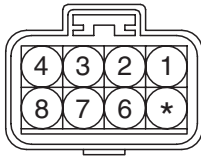
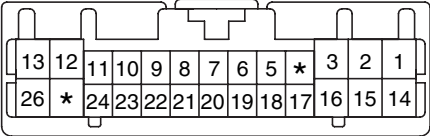
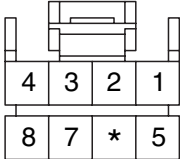
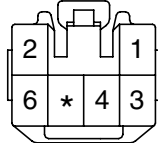
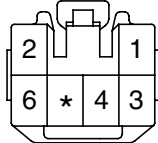
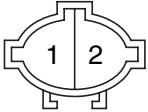
TAIL, PARKING & LICENSE LAMPS (3)			SD928-3
<p>E16</p>  <p>KUM_NMWP_06F_B</p>	<p>E17</p>  <p>KUM_NMWP_06F_B</p>	<p>E18</p>  <p>KUM_NMWP_08F_B</p>	<p>E19</p>  <p>KUM_NMWP_08F_B</p>
<p>M05-B</p>  <p>KET_0407_26F_W</p>	<p>M42</p>  <p>AMP_040M1_08F_B</p>	<p>R02</p>  <p>KET_090II_06F_W</p>	<p>R03</p>  <p>KET_090II_06F_W</p>
<p>R07</p>  <p>CR02M060</p>	<p>BLANK</p>	<p>BLANK</p>	<p>BLANK</p>

TAIL, PARKING & LICENSE LAMPS

TAIL, PARKING & LICENSE LAMPS (4)

SD928-4

MEMO

COURTESY & TRUNK LAMPS (1)

SD929-1

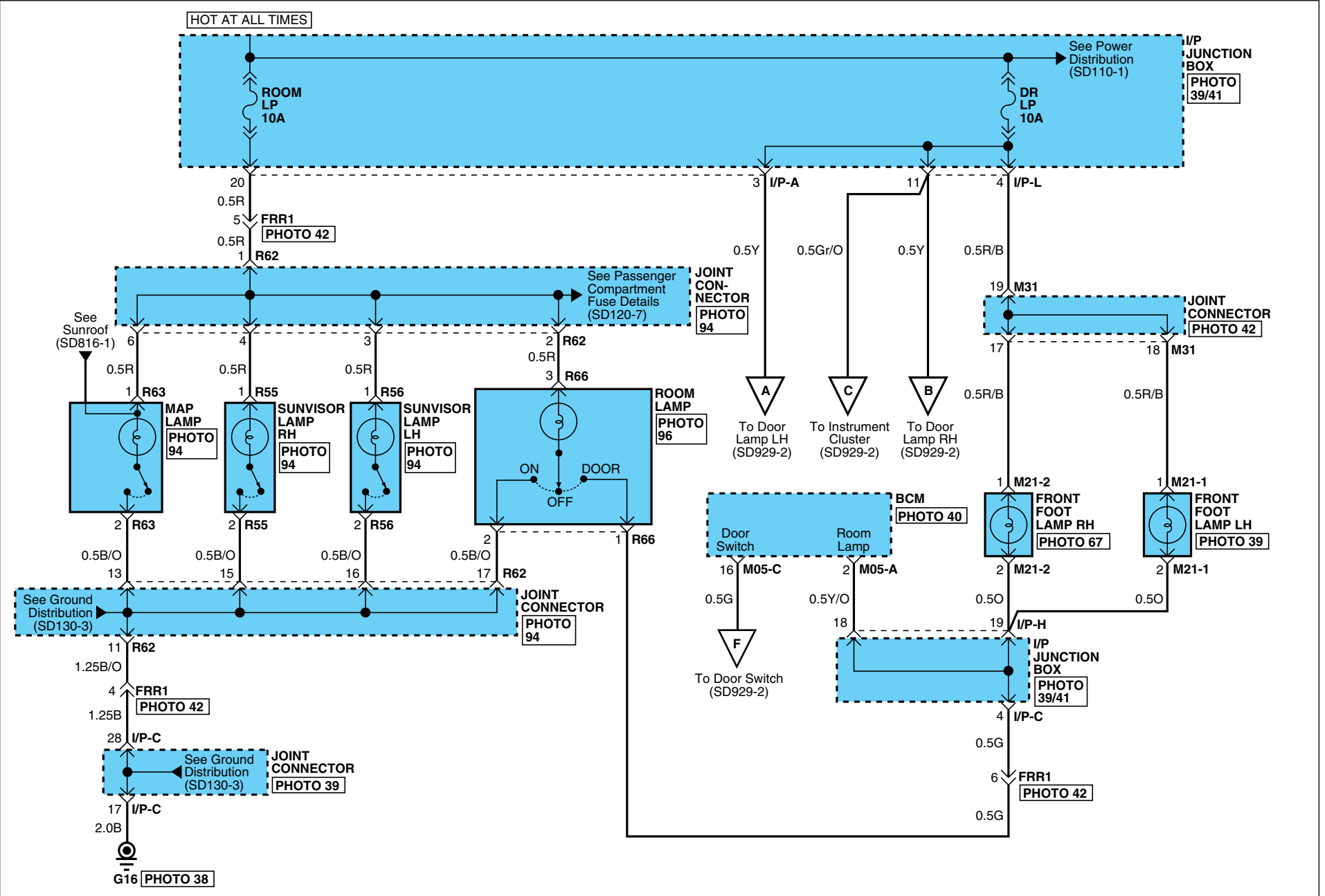

COURTESY & TRUNK LAMPS

COURTESY & TRUNK LAMPS (2)

SD929-2

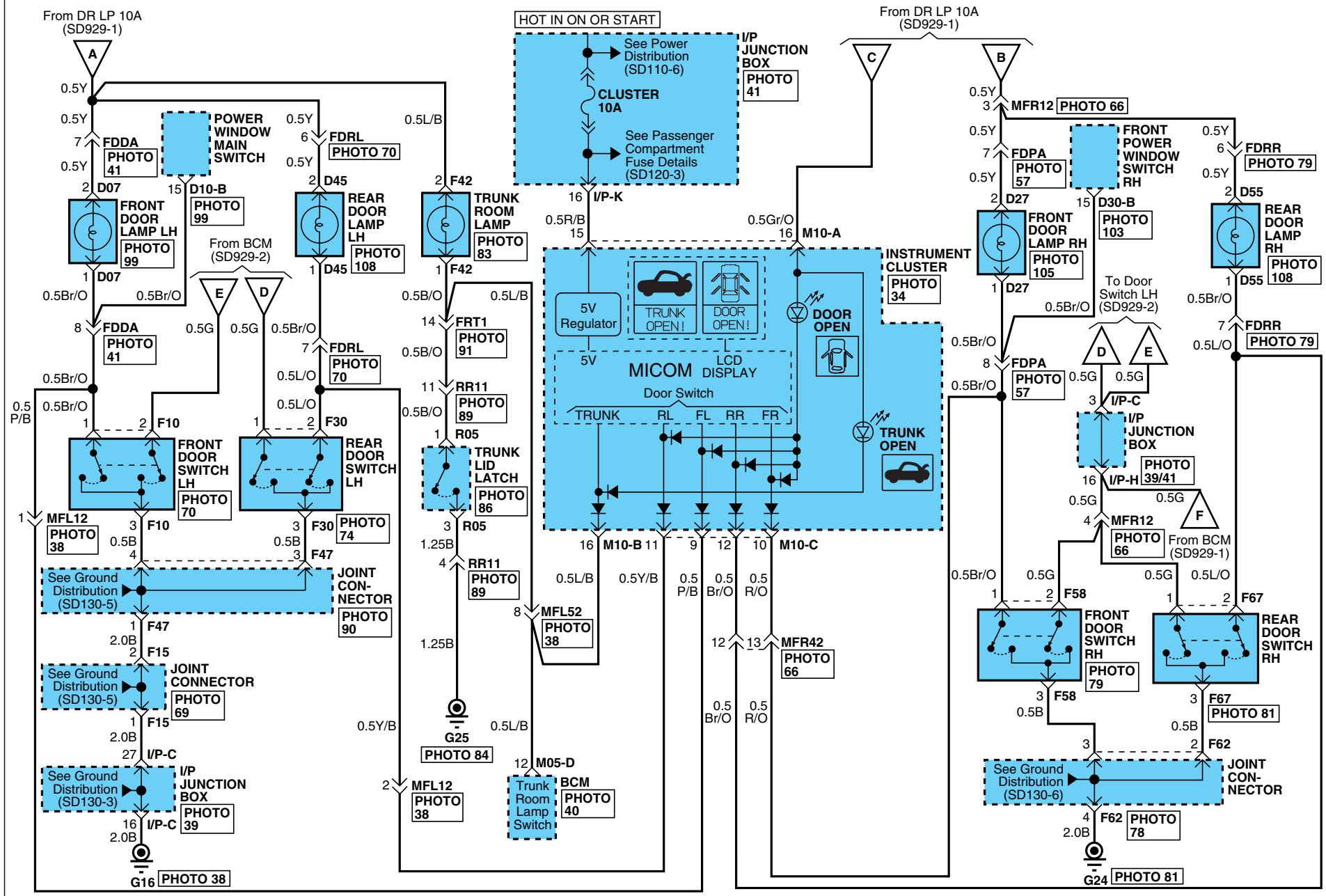

COURTESY & TRUNK LAMPS

COURTESY & TRUNK LAMPS (3)

SD929-3

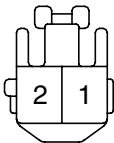
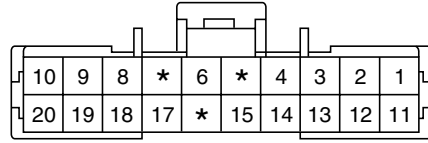
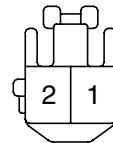
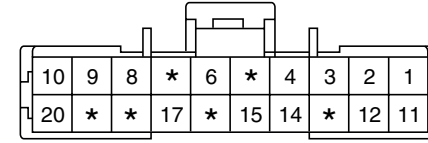
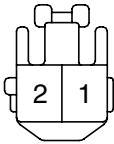
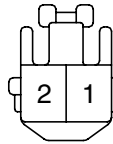
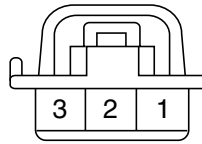
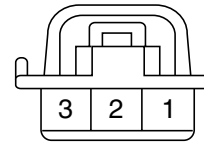
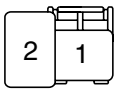
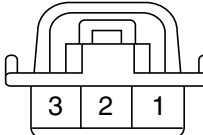
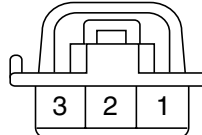
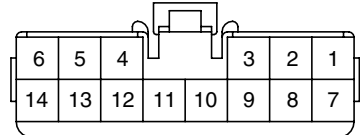
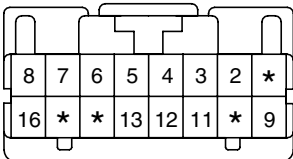
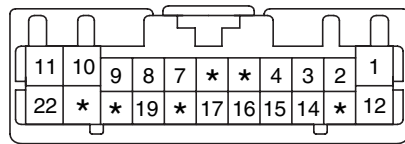
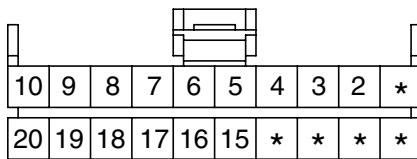
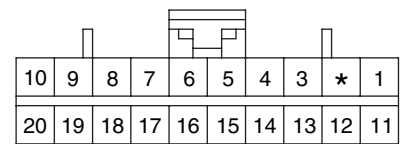
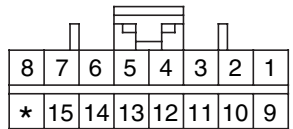
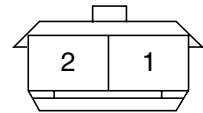
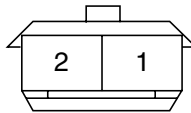
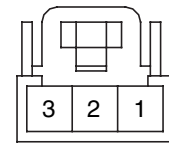
<p>D07</p>  <p>KET_090II_02F_W_L</p>	<p>D10-B</p>  <p>KET_SP_20F_W</p>	<p>D27</p>  <p>KET_090II_02F_W_L</p>	<p>D30-B</p>  <p>KET_SP_20F_W</p>
<p>D45</p>  <p>KET_090II_02F_W_L</p>	<p>D55</p>  <p>KET_090II_02F_W_L</p>	<p>F10</p>  <p>KET_62C_03F_W_DR</p>	<p>F30</p>  <p>KET_62C_03F_W_DR</p>
<p>F42</p>  <p>AMP_PLM2_02F_B</p>	<p>F58</p>  <p>KET_62C_03F_W_DR</p>	<p>F67</p>  <p>KET_62C_03F_W_DR</p>	<p>M05-A</p>  <p>KET_090II_14F_W</p>
<p>M05-C</p>  <p>KET_0407_16F_W</p>	<p>M05-D</p>  <p>KET_0407_22F_W</p>	<p>M10-A</p>  <p>AMP_040M1_20F_B</p>	<p>M10-B</p>  <p>AMP_040M2_20F_B</p>
<p>M10-C</p>  <p>AMP_040M2_16F_B</p>	<p>M21-1</p>  <p>KET_090_02F_W</p>	<p>M21-2</p>  <p>KET_090_02F_W</p>	<p>R05</p>  <p>AMP_070_03F_W</p>

COURTESY & TRUNK LAMPS

COURTESY & TRUNK LAMPS (4)

SD929-4

R55

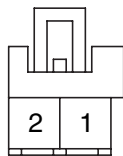

KUM_CDR_02F_W

R56

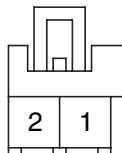

KUM_CDR_02F_W

R63

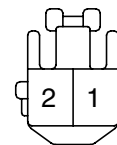

KET_090II_02F_W_L

R66

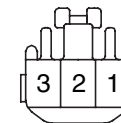

KET_090II_03F_W

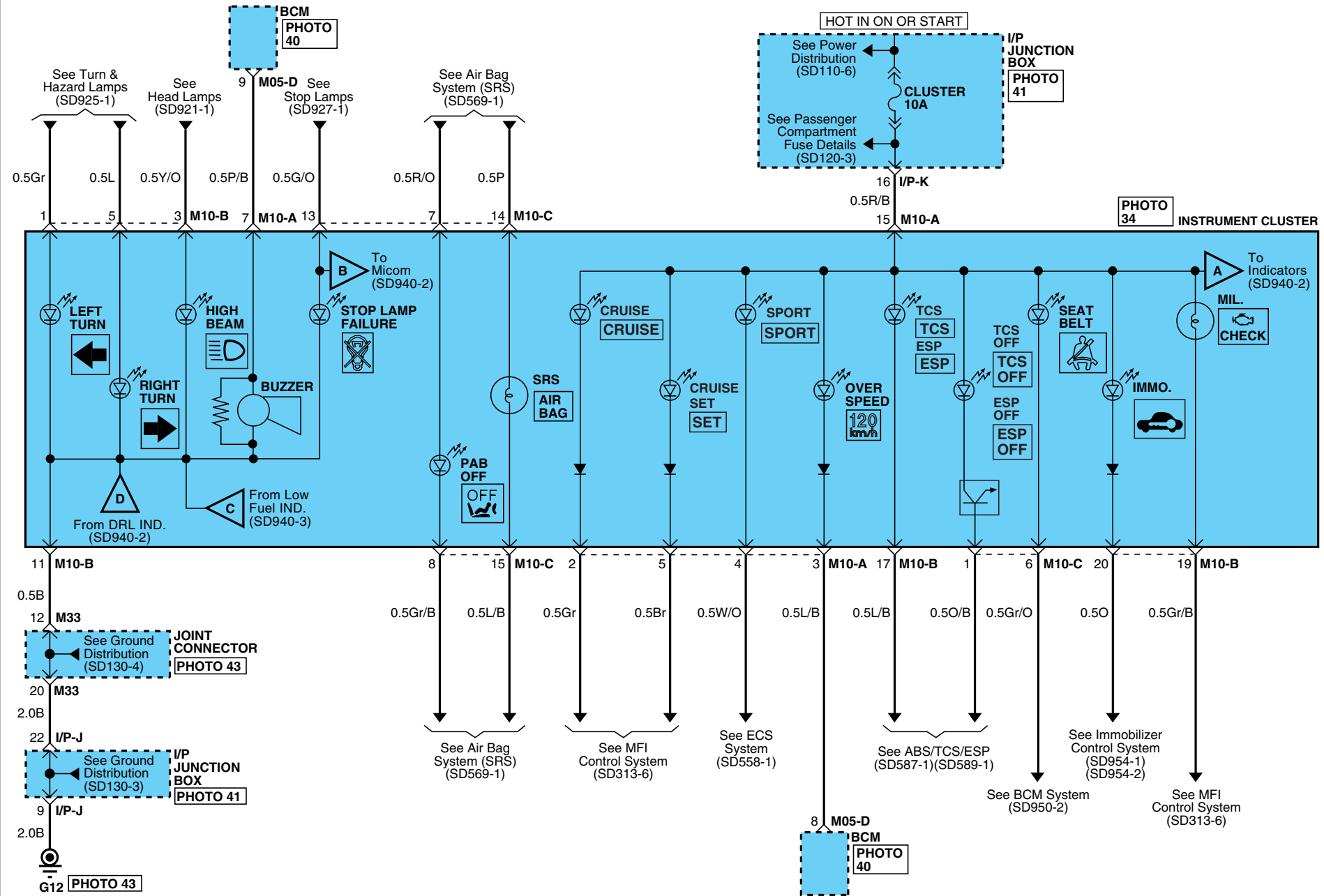

INDICATORS & GAUGES (1)

SD940-1

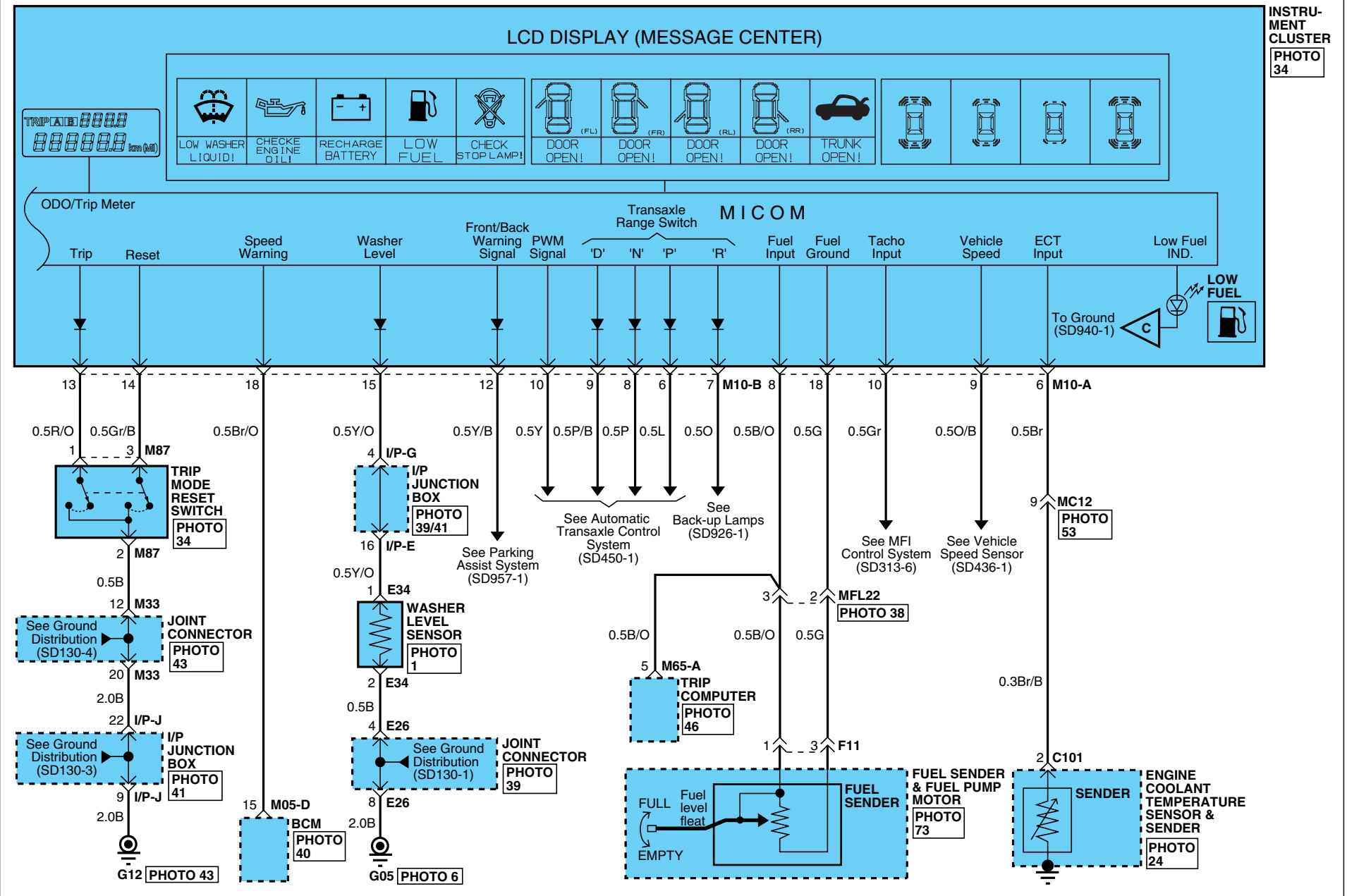

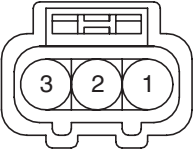
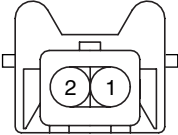

INDICATORS & GAUGES

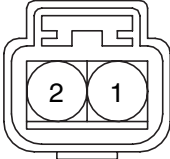
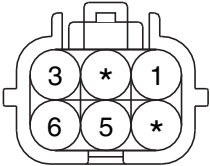
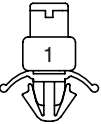
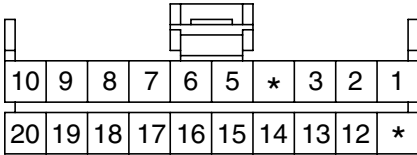
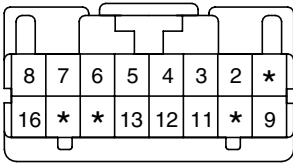
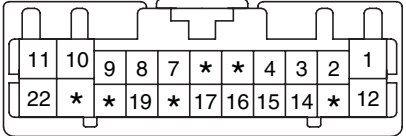
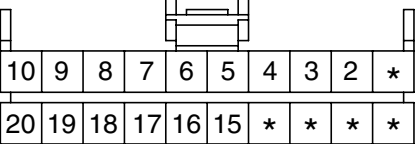
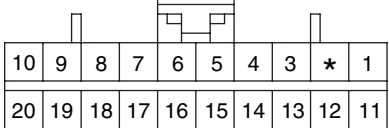
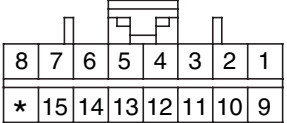
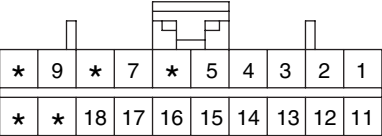
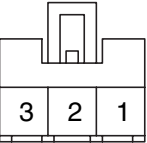
INDICATORS & GAUGES (4)			SD940-4
<p>C101</p>  <p>KUM_62Z_03F_B_WTS</p>	<p>C107</p>  <p>AMP_JPT_02F_B_CLIP</p>	<p>C111</p>  <p>KUM_NMWP_01F_B</p>	<p>E34</p>  <p>KUM_NMWP_02F_B</p>
<p>F11</p>  <p>KET_SWP_06F_B</p>	<p>F25</p>  <p>KET_250_01F_B_CLIP</p>	<p>F52-A</p>  <p>AMP_040M1_20F_B</p>	<p>M05-C</p>  <p>KET_0407_16F_W</p>
<p>M05-D</p>  <p>KET_0407_22F_W</p>	<p>M10-A</p>  <p>AMP_040M1_20F_B</p>	<p>M10-B</p>  <p>AMP_040M2_20F_B</p>	<p>M10-C</p>  <p>AMP_040M2_16F_B</p>
<p>M65-A</p>  <p>AMP_040M2_20F_B</p>	<p>M87</p>  <p>KUM_CDR_03F_W</p>	<p>BLANK</p>	<p>BLANK</p>

ILLUMINATIONS (1)

SD941-1

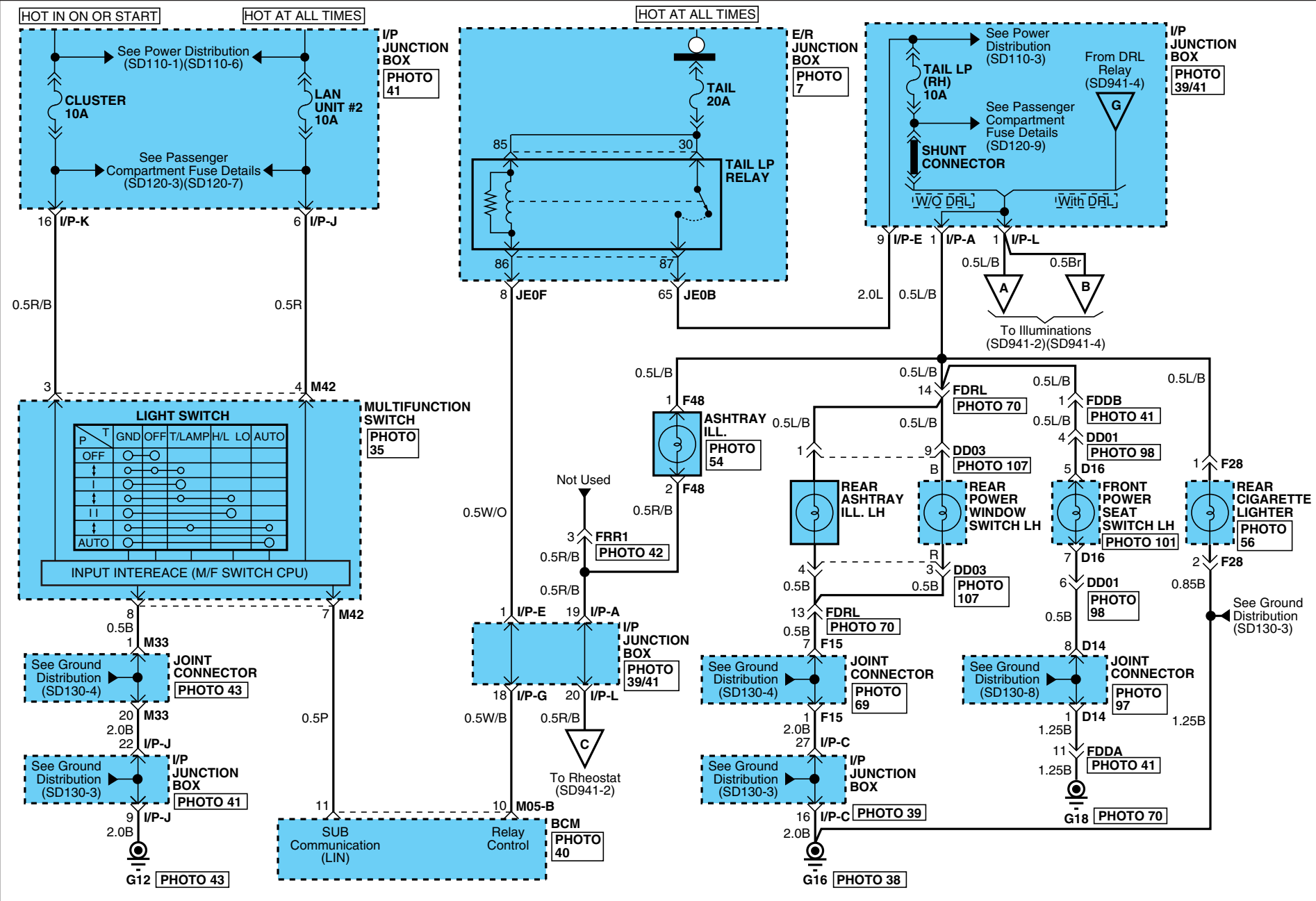

ILLUMINATIONS

ILLUMINATIONS (3)

SD941-3

JOINT CONNECTOR PHOTO 62

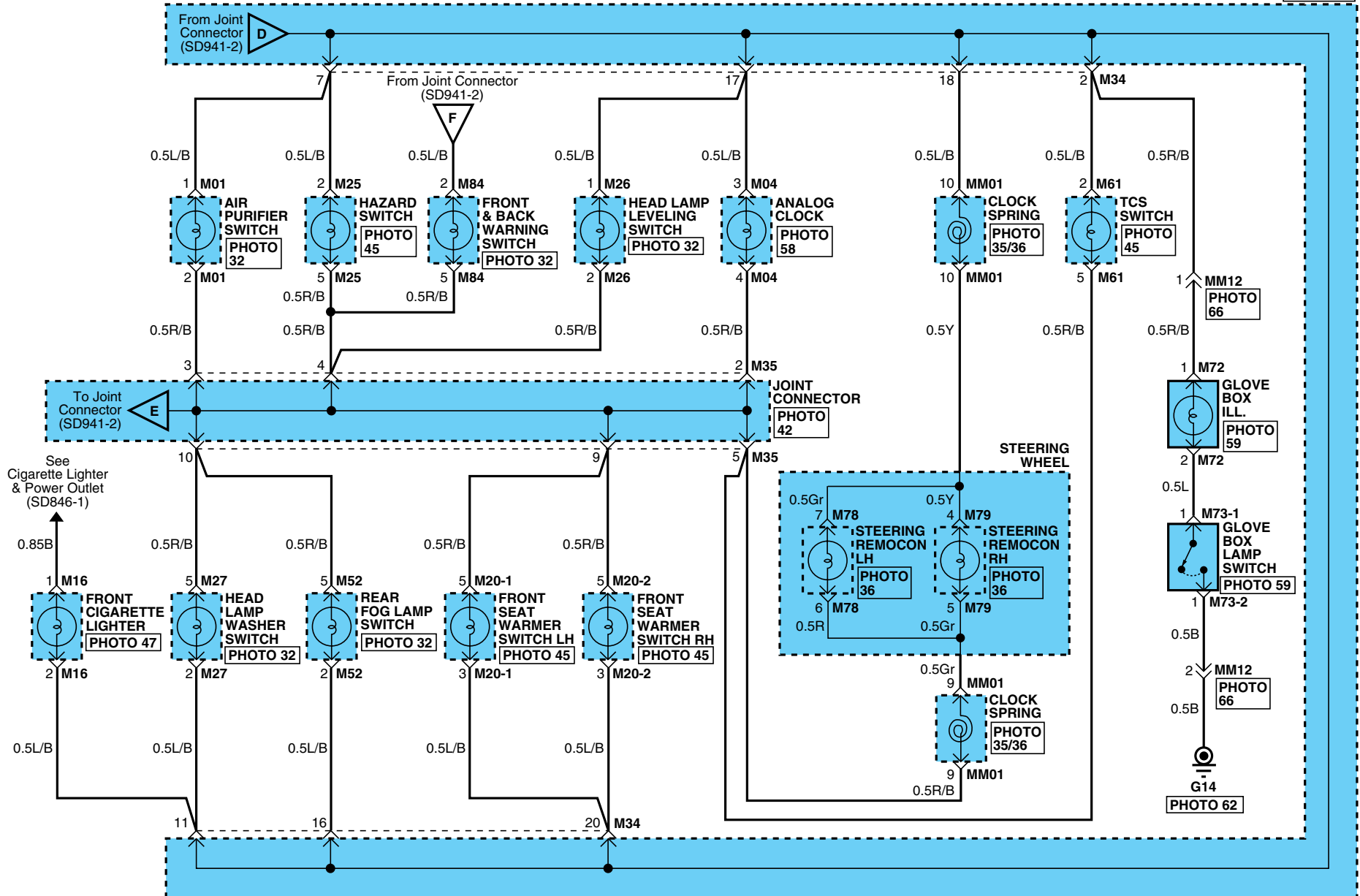

ILLUMINATIONS

ILLUMINATIONS (5)			SD941-5																																																				
<p>A60-2</p> <table border="1"> <tr><td>10</td><td>*</td><td>8</td><td>7</td><td>6</td><td>5</td><td>4</td><td>3</td><td>2</td><td>1</td></tr> <tr><td>20</td><td>*</td><td>18</td><td>17</td><td>16</td><td>15</td><td>14</td><td>13</td><td>12</td><td>11</td></tr> </table> <p>CR20F016</p>	10	*	8	7	6	5	4	3	2	1	20	*	18	17	16	15	14	13	12	11	<p>D16</p> <p>KET_MG_610404</p>	<p>D36</p> <p>KET_MG_610404</p>	<p>F28</p> <p>KET_250_03F_W</p>																																
10	*	8	7	6	5	4	3	2	1																																														
20	*	18	17	16	15	14	13	12	11																																														
<p>F48</p> <p>AMP_090III_02F_B</p>	<p>M01</p> <p>KUM_CDR_05F_L</p>	<p>M02-A</p> <table border="1"> <tr><td>12</td><td>11</td><td>10</td><td>*</td><td>*</td><td>7</td><td>6</td><td>5</td><td>4</td><td>3</td><td>2</td><td>1</td></tr> <tr><td>24</td><td>23</td><td>*</td><td>*</td><td>20</td><td>*</td><td>18</td><td>17</td><td>16</td><td>15</td><td>14</td><td>13</td></tr> </table> <p>KET_0409_24F_W</p>	12	11	10	*	*	7	6	5	4	3	2	1	24	23	*	*	20	*	18	17	16	15	14	13	<p>M04</p> <table border="1"> <tr><td>2</td><td>1</td></tr> <tr><td>5</td><td>4</td><td>3</td></tr> </table> <p>KET_PA_05F_W</p>	2	1	5	4	3																							
12	11	10	*	*	7	6	5	4	3	2	1																																												
24	23	*	*	20	*	18	17	16	15	14	13																																												
2	1																																																						
5	4	3																																																					
<p>M05-B</p> <table border="1"> <tr><td>13</td><td>12</td><td>11</td><td>10</td><td>9</td><td>8</td><td>7</td><td>6</td><td>5</td><td>*</td><td>3</td><td>2</td><td>1</td></tr> <tr><td>26</td><td>*</td><td>24</td><td>23</td><td>22</td><td>21</td><td>20</td><td>19</td><td>18</td><td>17</td><td>16</td><td>15</td><td>14</td></tr> </table> <p>KET_0407_26F_W</p>	13	12	11	10	9	8	7	6	5	*	3	2	1	26	*	24	23	22	21	20	19	18	17	16	15	14	<p>M10-A</p> <table border="1"> <tr><td>10</td><td>9</td><td>8</td><td>7</td><td>6</td><td>5</td><td>4</td><td>3</td><td>2</td><td>*</td></tr> <tr><td>20</td><td>19</td><td>18</td><td>17</td><td>16</td><td>15</td><td>*</td><td>*</td><td>*</td><td>*</td></tr> </table> <p>AMP_040M1_20F_B</p>	10	9	8	7	6	5	4	3	2	*	20	19	18	17	16	15	*	*	*	*	<p>M12</p> <table border="1"> <tr><td>*</td><td>*</td></tr> <tr><td>6</td><td>5</td><td>4</td><td>3</td></tr> </table> <p>AMP_090III_06F_W_2</p>	*	*	6	5	4	3	<p>M16</p> <p>KET_090II_03F_W</p>
13	12	11	10	9	8	7	6	5	*	3	2	1																																											
26	*	24	23	22	21	20	19	18	17	16	15	14																																											
10	9	8	7	6	5	4	3	2	*																																														
20	19	18	17	16	15	*	*	*	*																																														
*	*																																																						
6	5	4	3																																																				
<p>M20-1</p> <table border="1"> <tr><td>2</td><td>1</td></tr> <tr><td>6</td><td>5</td><td>4</td><td>3</td></tr> </table> <p>KET_090II_06F_Y</p>	2	1	6	5	4	3	<p>M20-2</p> <table border="1"> <tr><td>2</td><td>1</td></tr> <tr><td>6</td><td>5</td><td>4</td><td>3</td></tr> </table> <p>KET_090II_06F_B</p>	2	1	6	5	4	3	<p>M25</p> <table border="1"> <tr><td>2</td><td>*</td></tr> <tr><td>*</td><td>5</td><td>4</td><td>3</td></tr> </table> <p>KET_090II_06F_W</p>	2	*	*	5	4	3	<p>M26</p> <table border="1"> <tr><td>1</td></tr> <tr><td>5</td><td>4</td><td>3</td><td>2</td></tr> </table> <p>KUM_CDR_05F_B</p>	1	5	4	3	2																													
2	1																																																						
6	5	4	3																																																				
2	1																																																						
6	5	4	3																																																				
2	*																																																						
*	5	4	3																																																				
1																																																							
5	4	3	2																																																				
<p>M27</p> <table border="1"> <tr><td>2</td><td>*</td></tr> <tr><td>*</td><td>5</td><td>4</td><td>3</td></tr> </table> <p>KET_090II_06F_L</p>	2	*	*	5	4	3	<p>M37</p> <table border="1"> <tr><td>8</td><td>*</td><td>6</td><td>5</td><td>4</td><td>3</td><td>*</td><td>1</td></tr> <tr><td>16</td><td>*</td><td>*</td><td>13</td><td>12</td><td>11</td><td>10</td><td>9</td></tr> </table> <p>AMP_040M1_16F_B</p>	8	*	6	5	4	3	*	1	16	*	*	13	12	11	10	9	<p>M42</p> <table border="1"> <tr><td>4</td><td>3</td><td>2</td><td>1</td></tr> <tr><td>8</td><td>7</td><td>*</td><td>5</td></tr> </table> <p>AMP_040M1_08F_B</p>	4	3	2	1	8	7	*	5	<p>M50</p> <table border="1"> <tr><td>2</td><td>1</td></tr> <tr><td>5</td><td>4</td><td>3</td></tr> </table> <p>KET_PA_05F_W</p>	2	1	5	4	3																	
2	*																																																						
*	5	4	3																																																				
8	*	6	5	4	3	*	1																																																
16	*	*	13	12	11	10	9																																																
4	3	2	1																																																				
8	7	*	5																																																				
2	1																																																						
5	4	3																																																					

ILLUMINATIONS

ILLUMINATIONS (6)			SD941-6
<p>M51</p> <p>AMP_090IIL_06F_L_2</p>	<p>M52</p> <p>KET_090IIL_06F_G</p>	<p>M53</p> <p>KET_090IIL_06F_L</p>	<p>M61</p> <p>KET_090IIL_06F_R</p>
<p>M65-A</p> <p>AMP_040M2_20F_B</p>	<p>M72</p> <p>AMP_PLM2_02F_B</p>	<p>M73-1</p> <p>KET_187_01F_N</p>	<p>M73-2</p> <p>KET_187_01F_N</p>
<p>M78</p> <p>KET_SDL_8F</p>	<p>M79</p> <p>KET_SDL_8F</p>	<p>M80</p> <p>KET_070_06F_Y</p>	<p>M81</p> <p>KET_090IIL_02F_W_SPK</p>
<p>M84</p> <p>KET_090IIL_06F_Gr</p>	<p>S81</p> <p>KET_090IIL_06F_B</p>	<p>S83-B</p> <p>AMP_040MKIIL_16F</p>	<p>S84</p> <p>KET_090IIL_06F_W</p>
<p>S104</p> <p>KET_090IIL_06F_B</p>	<p>S105-B</p> <p>AMP_040MKIIL_16F</p>	<p>S107</p> <p>KET_090IIL_06F_W</p>	<p>BLANK</p>

CLOCK (1)

SD945-1

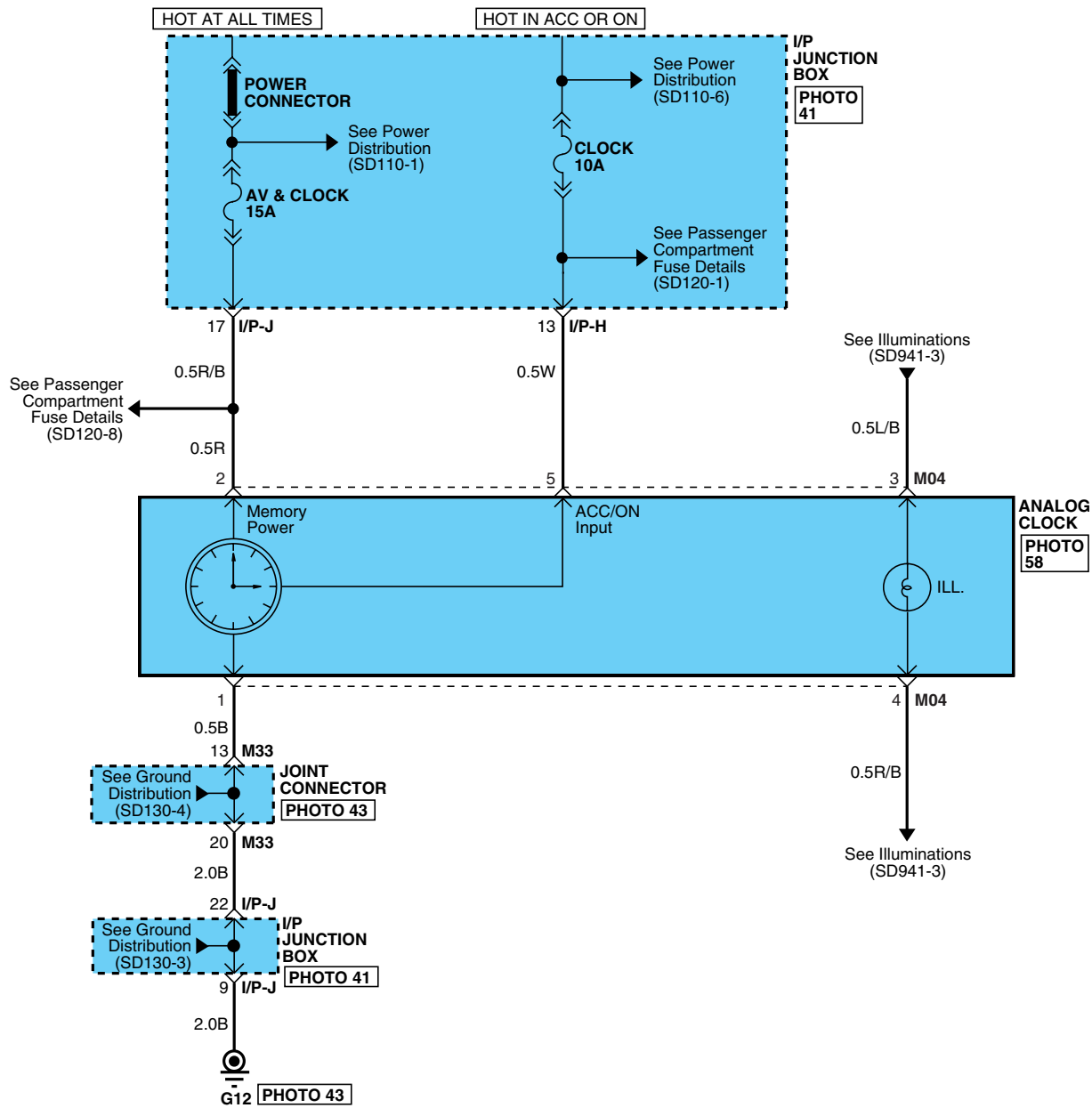

CLOCK

CLOCK (2)

SD945-2

M04

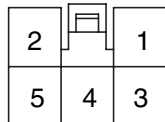

KET_PA_05F_W

BLANK

BLANK

BLANK

BCM (BODY CONTROL MODULE) SYSTEM (1)

SD950-1

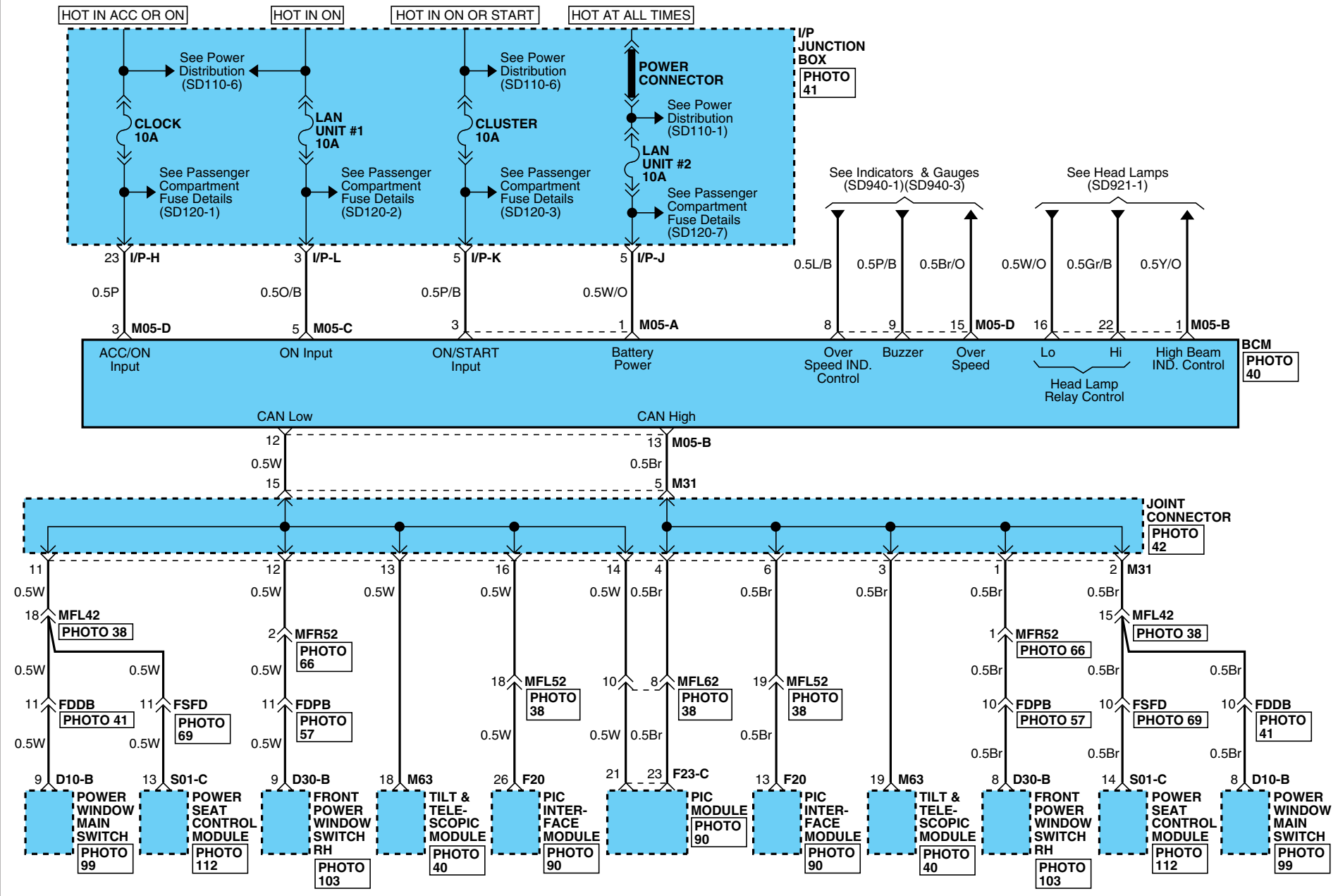

BCM (BODY CONTROL MODULE) SYSTEM

BCM (BODY CONTROL MODULE) SYSTEM (3)

SD950-3

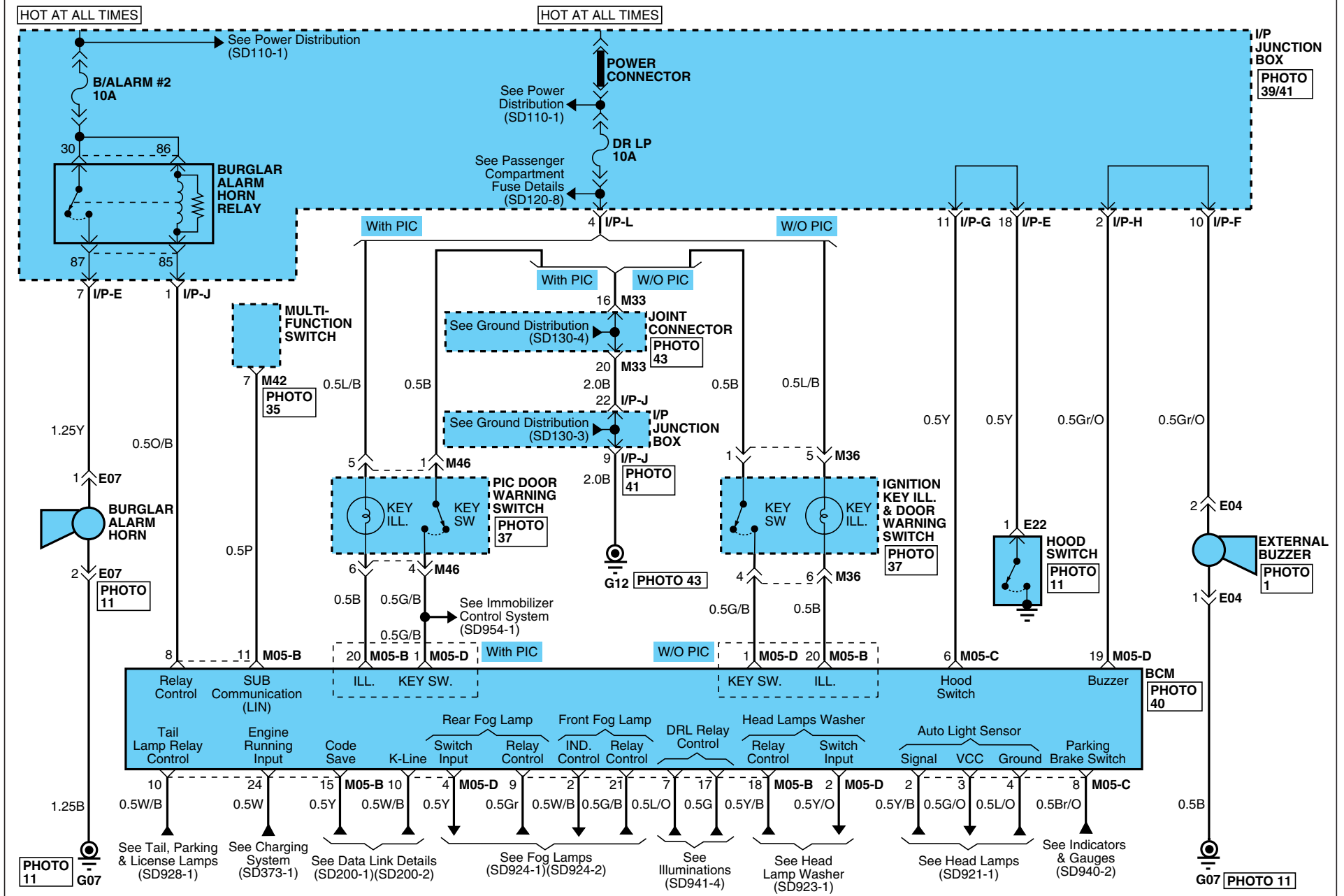

BCM (BODY CONTROL MODULE) SYSTEM

BCM (BODY CONTROL MODULE) SYSTEM (4)

SD950-4

<p>D10-B</p> <p>KET_SP_20F_W</p>	<p>D30-B</p> <p>KET_SP_20F_W</p>	<p>E04</p> <p>SUM_090IWP_02F_B_1</p>	<p>E07</p> <p>MLX_HORN_02F_B_FILTER</p>
<p>E22</p> <p>KUM_NMWP_01F_B</p>	<p>F20</p> <p>KET_0407_26F_W</p>	<p>F23-C</p> <p>SIE_PIC_23F_L</p>	<p>M05-A</p> <p>KET_090II_14F_W</p>
<p>M05-B</p> <p>KET_0407_26F_W</p>	<p>M05-C</p> <p>KET_0407_16F_W</p>	<p>M05-D</p> <p>KET_0407_22F_W</p>	<p>M10-A</p> <p>AMP_040M1_20F_B</p>
<p>M10-C</p> <p>AMP_040M2_16F_B</p>	<p>M36</p> <p>KET_090II_08M_W</p>	<p>M42</p> <p>AMP_040M1_08F_B</p>	<p>M46</p> <p>KET_090II_08F_W</p>
<p>M63</p> <p>KET_0407_26F_W</p>	<p>M90</p> <p>KET_040III_04F_W</p>	<p>S01-C</p> <p>AMP_040MII_20F</p>	<p>BLANK</p>

IMMOBILIZER CONTROL SYSTEM (1)

SD954-1

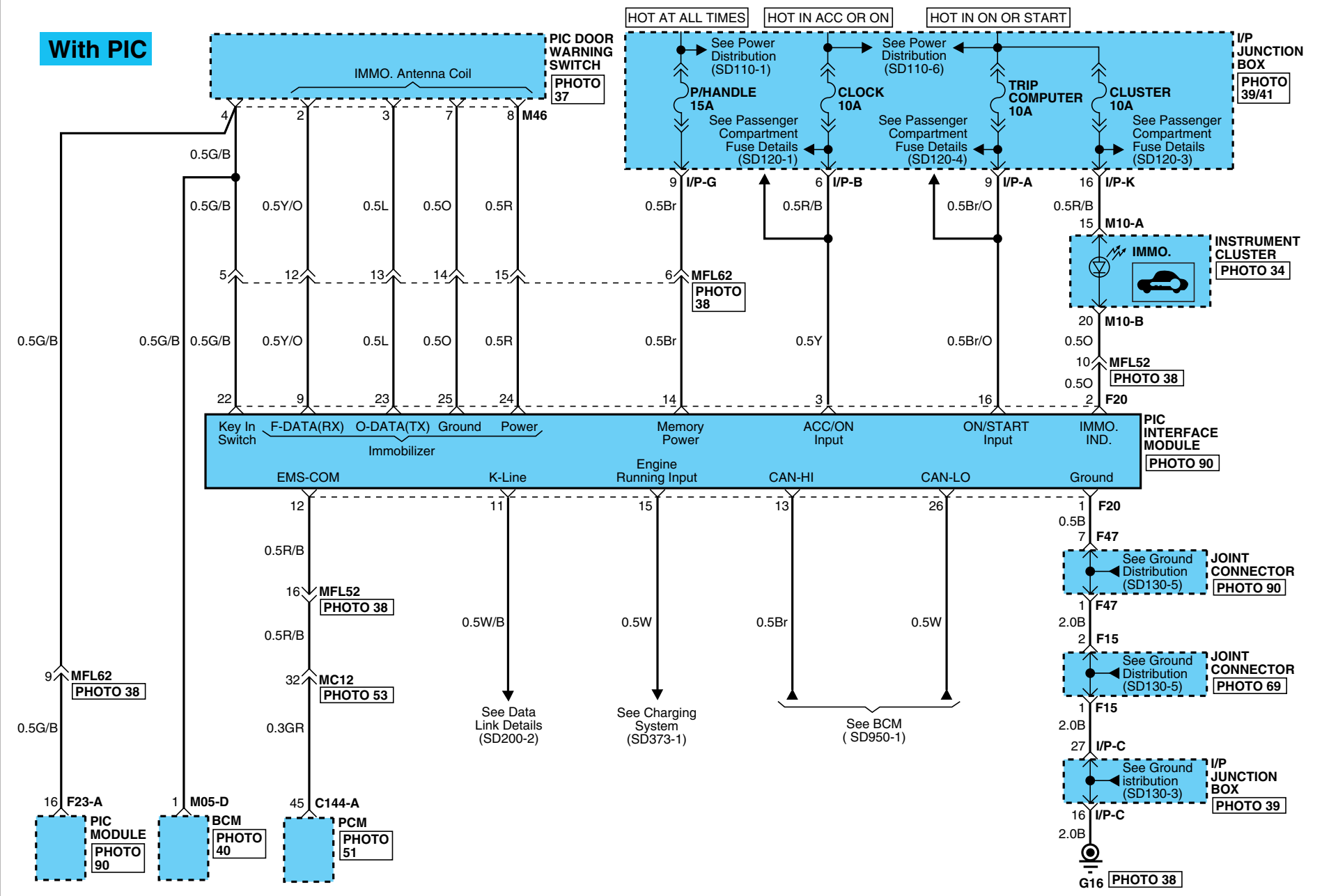

IMMOBILIZER CONTROL SYSTEM

IMMOBILIZER CONTROL SYSTEM (3)

SD954-3

C144-A

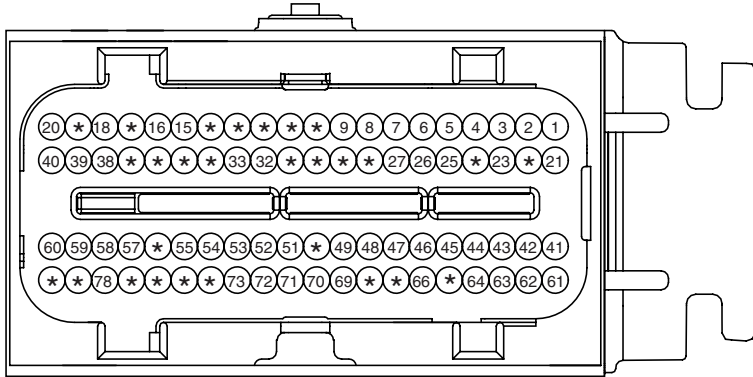

PKD_ECU_80F_GR_3

F20

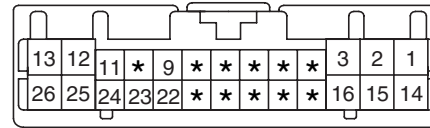

KET_0407_26F_W

F23-A

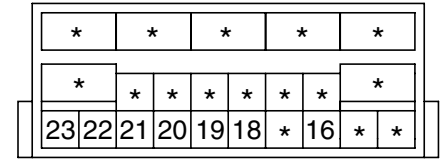

SIE_PIC_23F_GR

M05-D

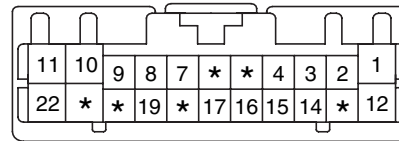

KET_0407_22F_W

M10-A

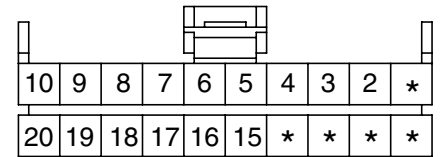

AMP_040M1_20F_B

M10-B

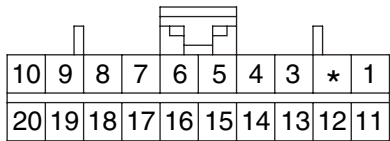

AMP_040M2_20F_B

M36

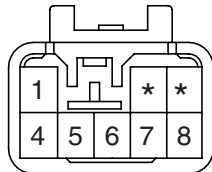

KET_090I_08M_W

M46

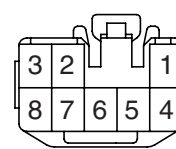

KET_090I_08F_W

M85

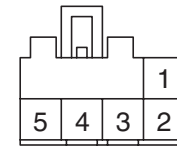

KUM_CDR_05F_W

IMMOBILIZER CONTROL SYSTEM

IMMOBILIZER CONTROL SYSTEM (4)

SD954-4

MEMO

PARKING ASSIST SYSTEM (1)

SD957-1

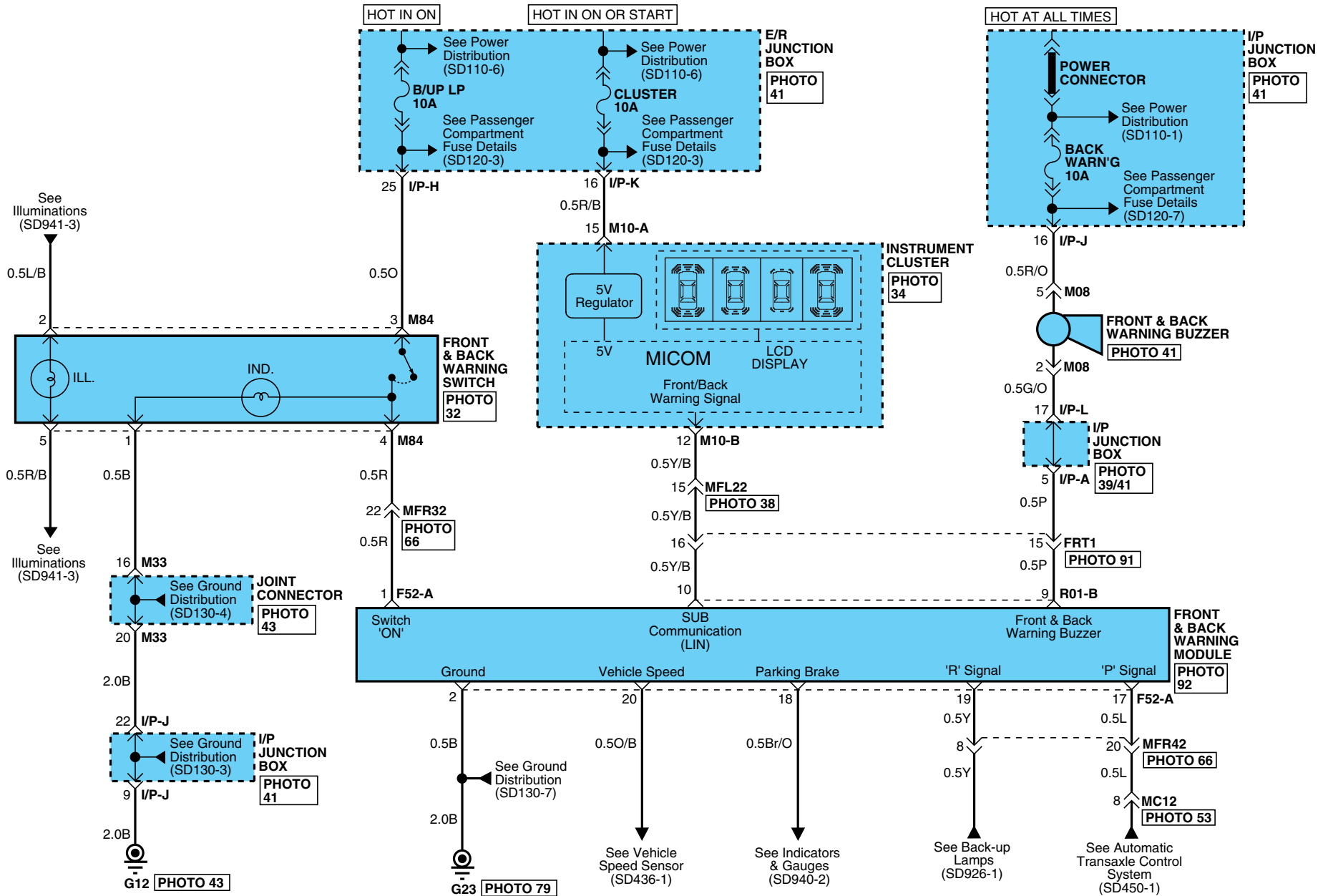

PARKING ASSIST SYSTEM

PARKING ASSIST SYSTEM (2)

SD957-2

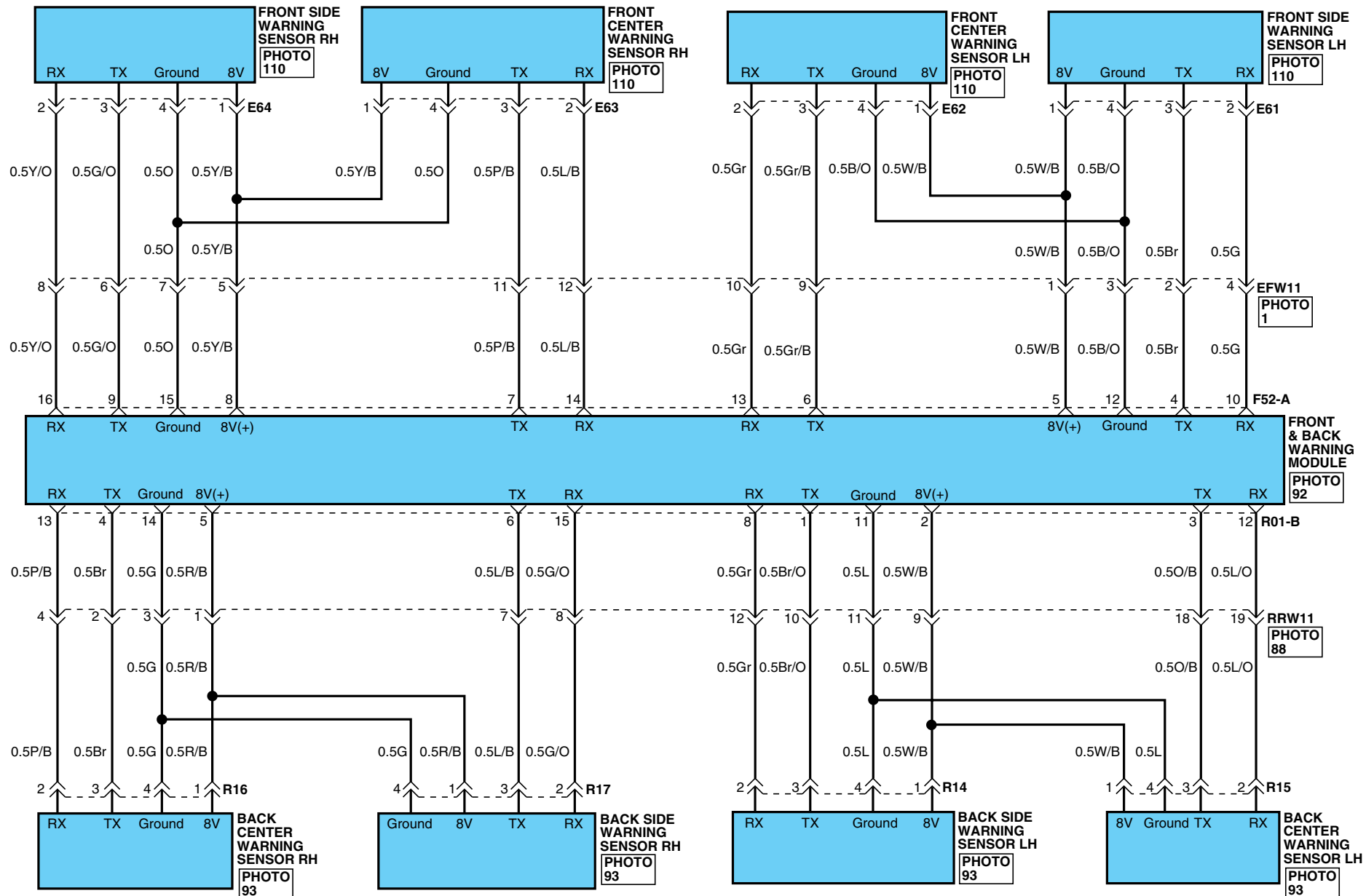

PARKING ASSIST SYSTEM

PARKING ASSIST SYSTEM (3)

SD957-3

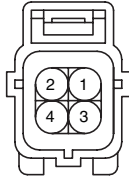
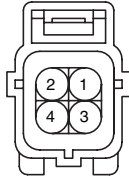
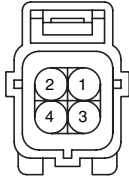
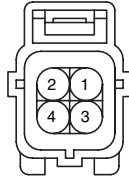
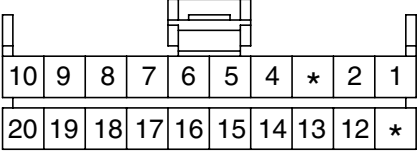
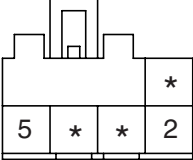
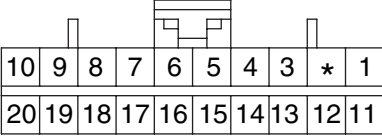
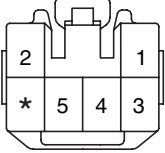
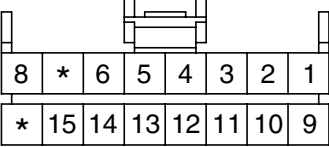
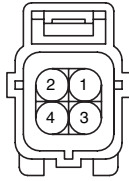
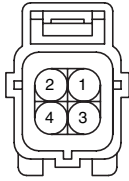
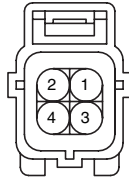
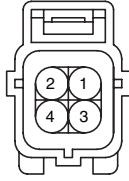
<p>E61</p>  <p>AMP_EJWP_04F_B</p>	<p>E62</p>  <p>AMP_EJWP_04F_B</p>	<p>E63</p>  <p>AMP_EJWP_04F_B</p>	<p>E64</p>  <p>AMP_EJWP_04F_B</p>
<p>F52-A</p>  <p>AMP_040M1_20F_B</p>	<p>M08</p>  <p>KUM_CDR_05F_W</p>	<p>M10-B</p>  <p>AMP_040M2_20F_B</p>	<p>M84</p>  <p>KET_090II_06F_Gr</p>
<p>R01-B</p>  <p>AMP_040M1_16F_W</p>	<p>R14</p>  <p>AMP_EJWP_04F_B</p>	<p>R15</p>  <p>AMP_EJWP_04F_B</p>	<p>R16</p>  <p>AMP_EJWP_04F_B</p>
<p>R17</p>  <p>AMP_EJWP_04F_B</p>	<p>BLANK</p>	<p>BLANK</p>	<p>BLANK</p>

PARKING ASSIST SYSTEM

PARKING ASSIST SYSTEM (4)

SD957-4

MEMO

AUDIO SYSTEM (1)

SD961-1

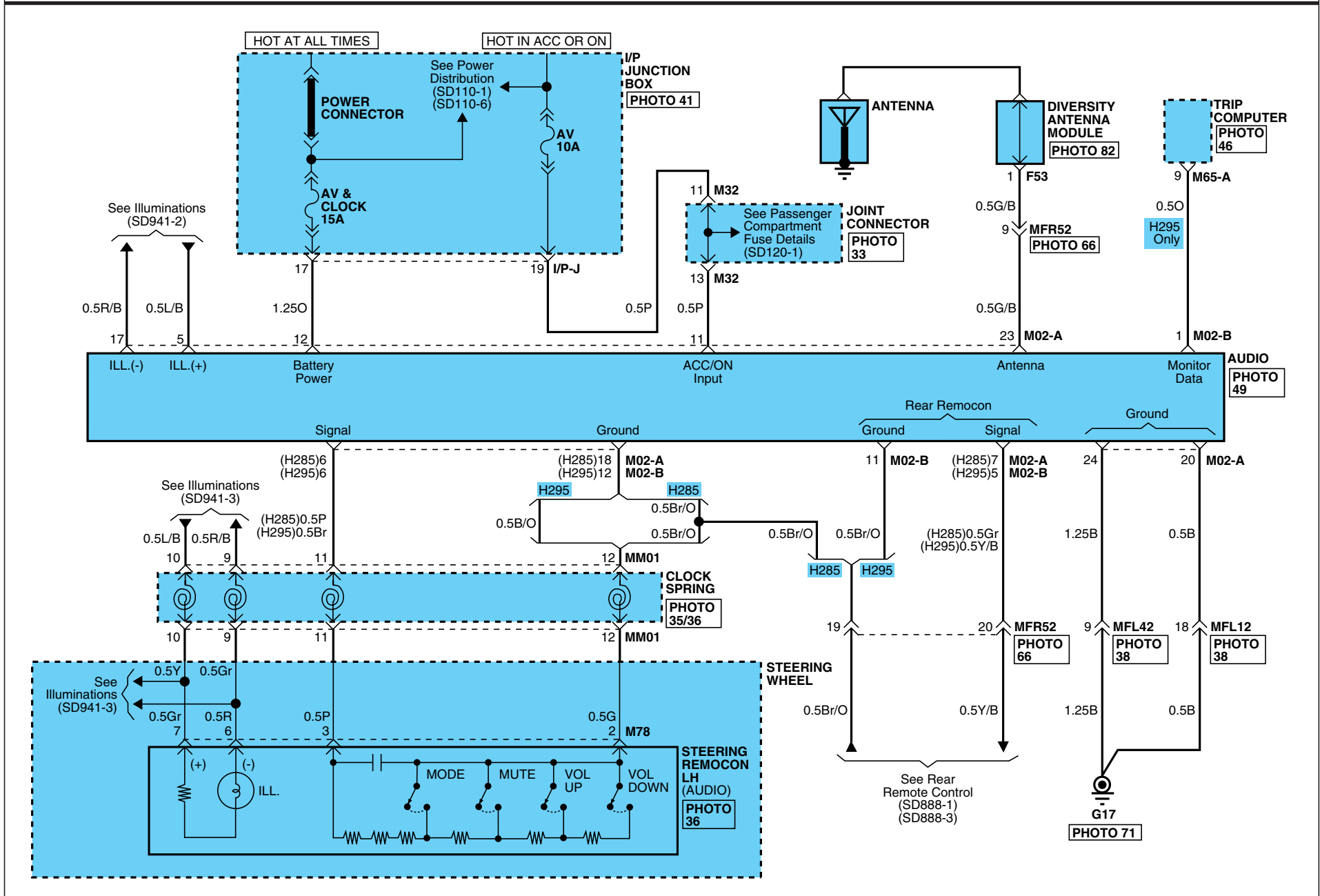

AUDIO SYSTEM

AUDIO SYSTEM (3)

SD961-3

H285 AUDIO With BUILT-IN AMP

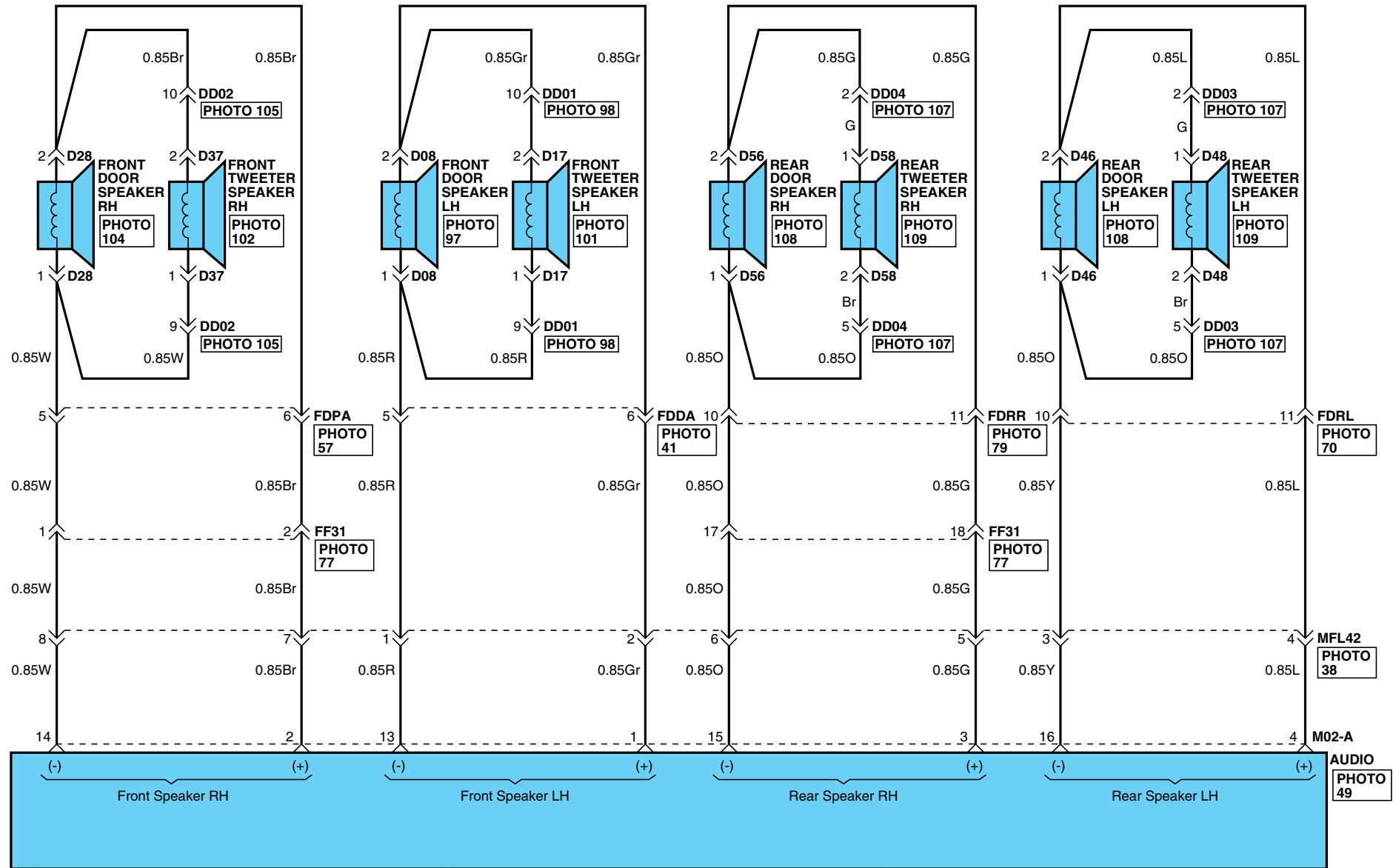

AUDIO SYSTEM

AUDIO SYSTEM (4)

SD961-4

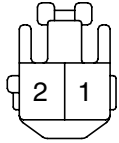
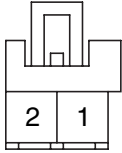
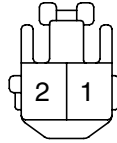
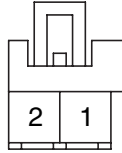
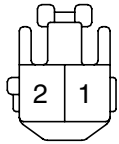
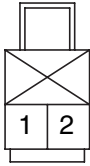
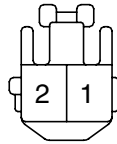
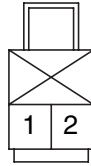
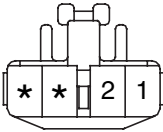
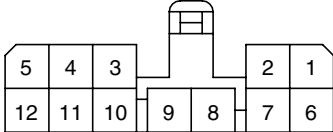
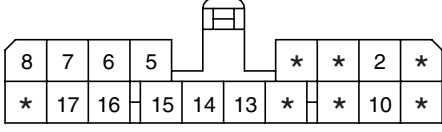
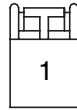
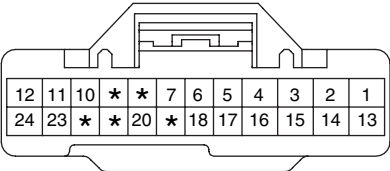
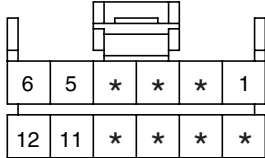
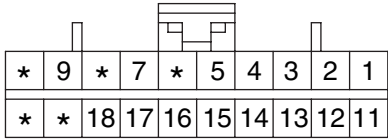
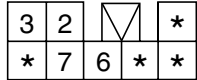
<p>D08</p>  <p>KET_090I1_02F_W_L</p>	<p>D17</p>  <p>KUM_CDR_02F_W</p>	<p>D28</p>  <p>KET_090I1_02F_W_L</p>	<p>D37</p>  <p>KUM_CDR_02F_W</p>
<p>D46</p>  <p>KET_090I1_02F_W_L</p>	<p>D48</p>  <p>CR02M061</p>	<p>D56</p>  <p>KET_090I1_02F_W_L</p>	<p>D58</p>  <p>CR02M061</p>
<p>F44</p>  <p>KET_090I1_04F_W</p>	<p>F46-A</p>  <p>AMP_070_12F_W</p>	<p>F46-B</p>  <p>AMP_070_18F_W</p>	<p>F53</p>  <p>AMP_PLM2_01F_B_187</p>
<p>M02-A</p>  <p>KET_0409_24F_W</p>	<p>M02-B</p>  <p>AMP_040M1_12F_B</p>	<p>M65-A</p>  <p>AMP_040M2_20F_B</p>	<p>M78</p>  <p>KET_SDL_8F</p>

TRIP COMPUTER (1)

SD965-1

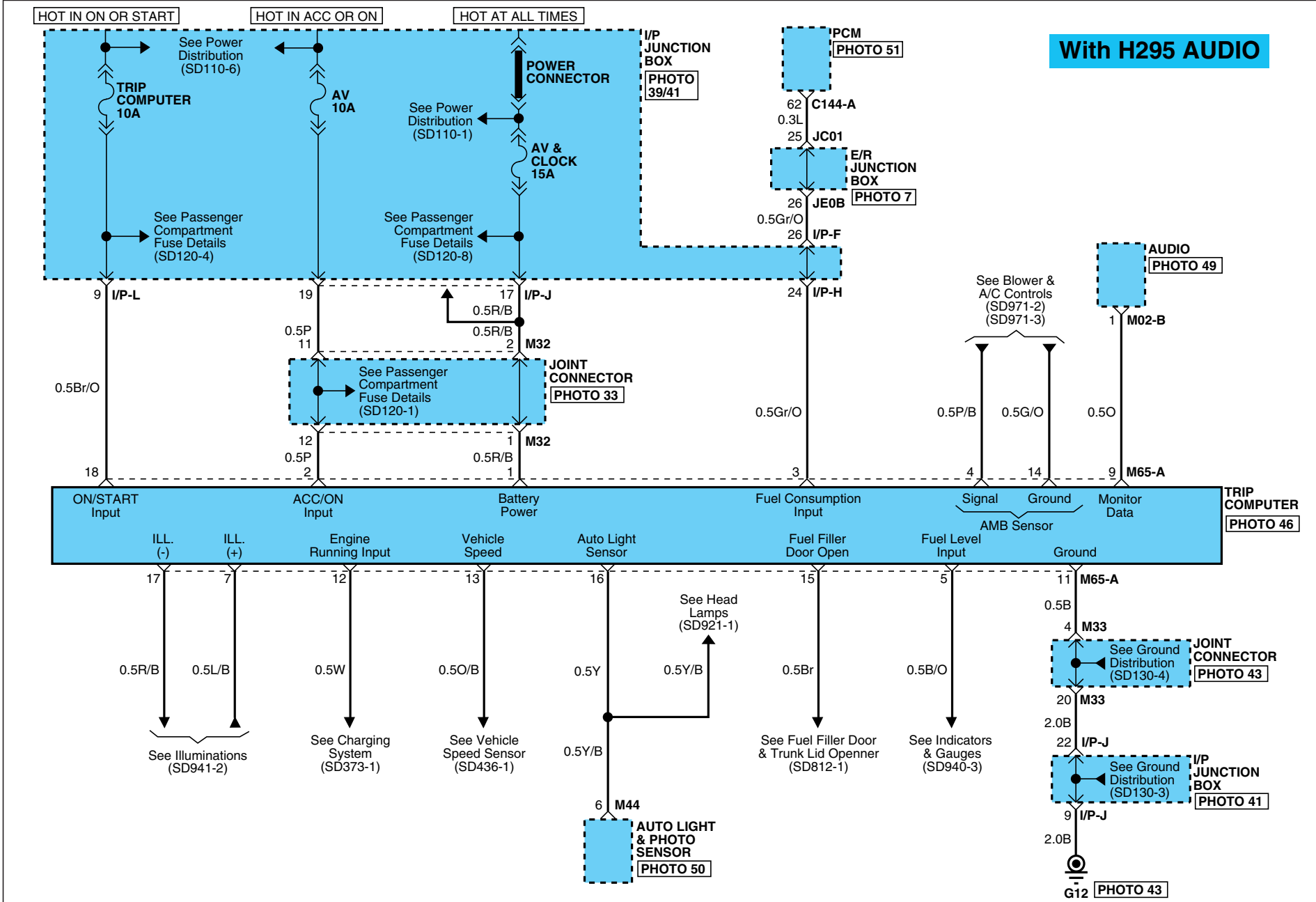

TRIP COMPUTER

TRIP COMPUTER (2)

SD965-2

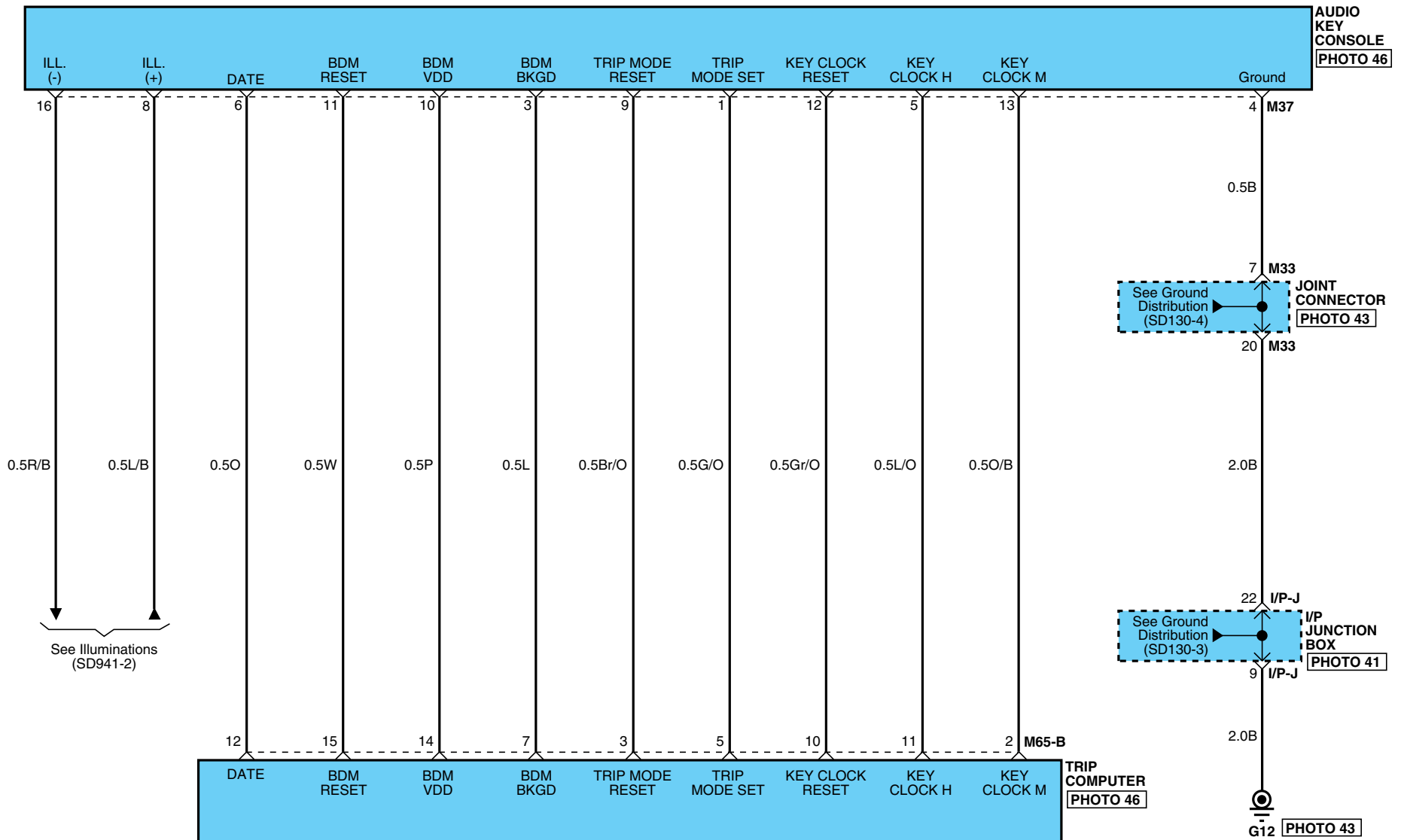

TRIP COMPUTER

TRIP COMPUTER (3)

SD965-3

C144-A

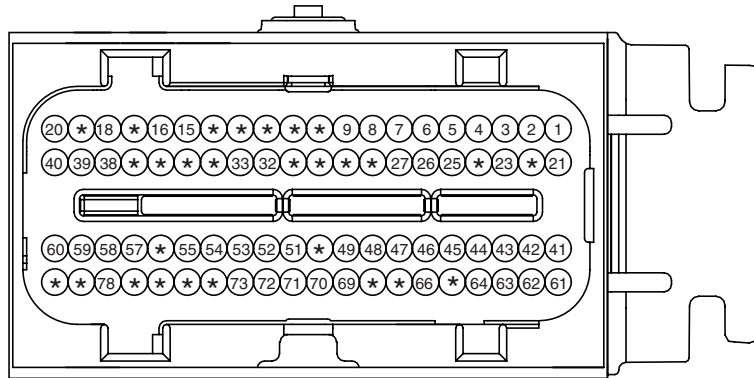

PKD_ECU_80F_GR_3

M02-A

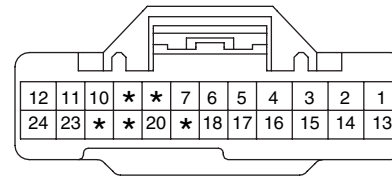

KET_0409_24F_W

M37

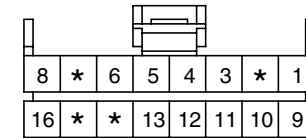

AMP_040M1_16F_B

M44

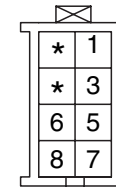

KET_030_08F_GR

M65-A

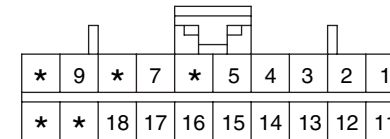

AMP_040M2_20F_B

M65-B

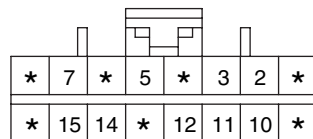

AMP_040M2_16F_B

BLANK

BLANK

BLANK

TRIP COMPUTER

TRIP COMPUTER (4)

SD965-4

MEMO

HORNS (1)

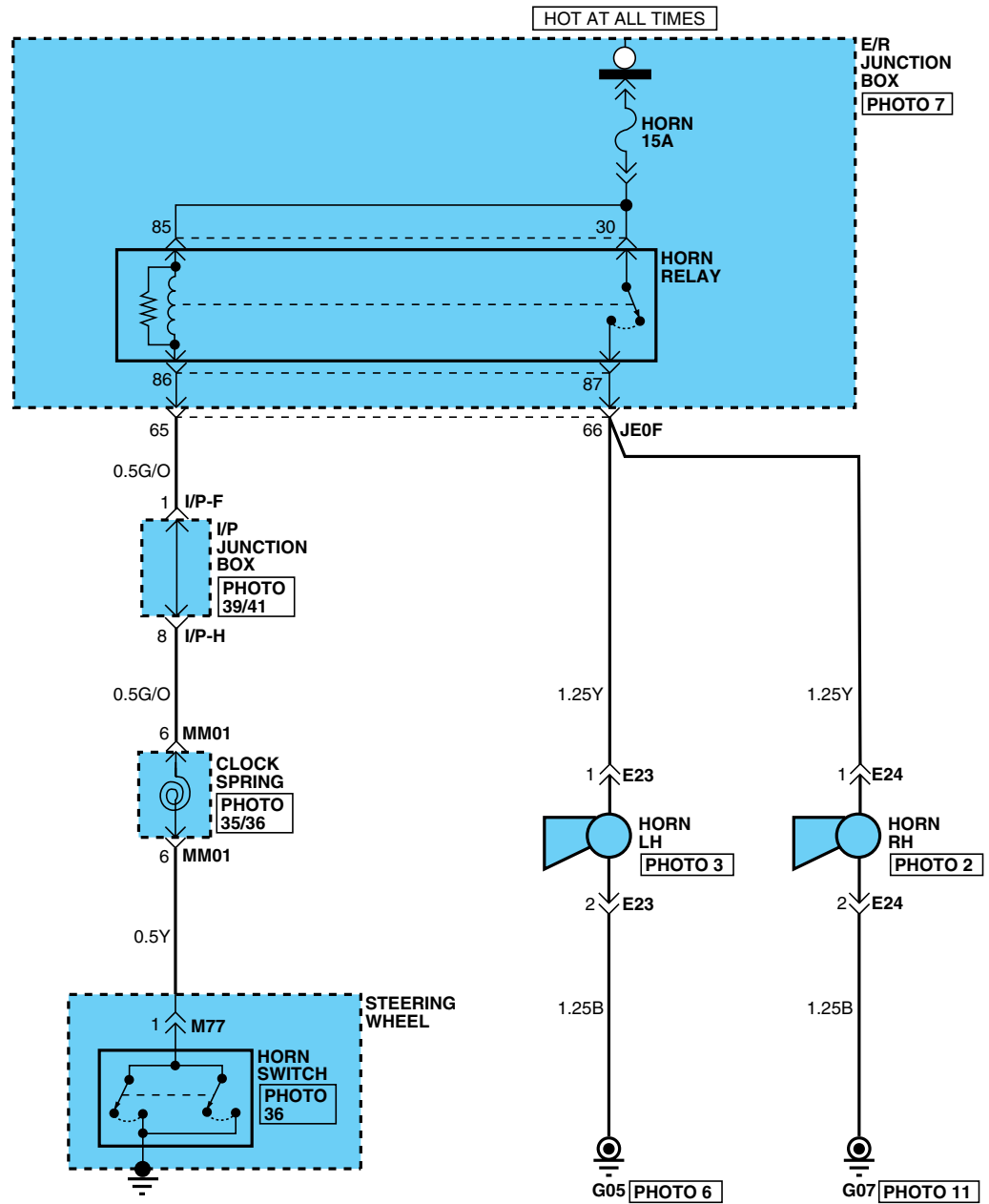

HORNS

HORNS (2)

SD968-2

E23

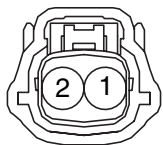

MLX_HORN_02F_B_FILT

E24

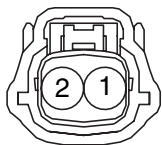

MLX_HORN_02F_B_FILT

M77

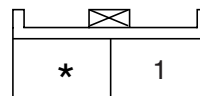

KUM_CDR_2F

BLANK

BLOWER & A/C CONTROLS (1)

SD971-1

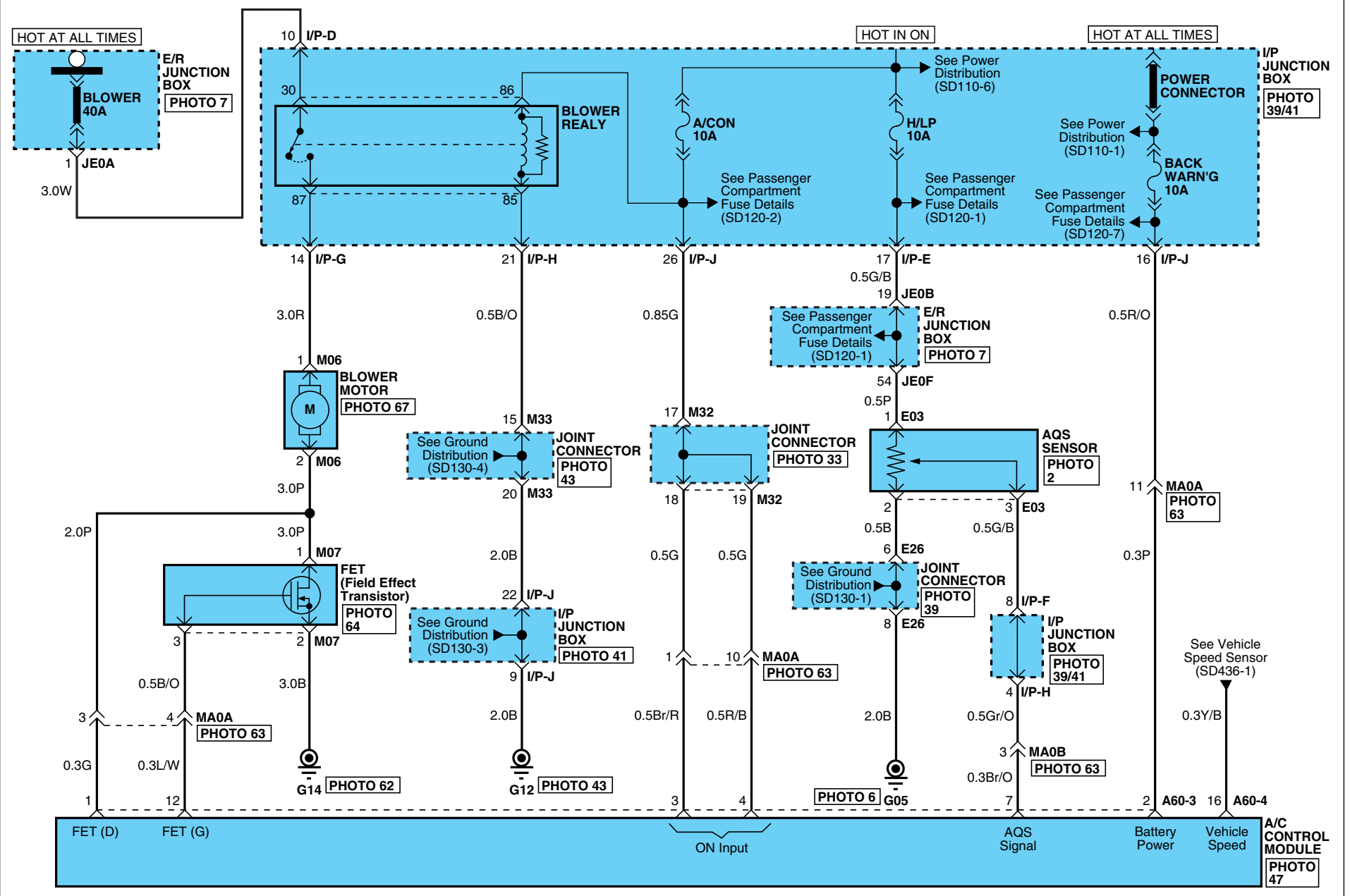

BLOWER & A/C CONTROLS

BLOWER & A/C CONTROLS (2)

SD971-2

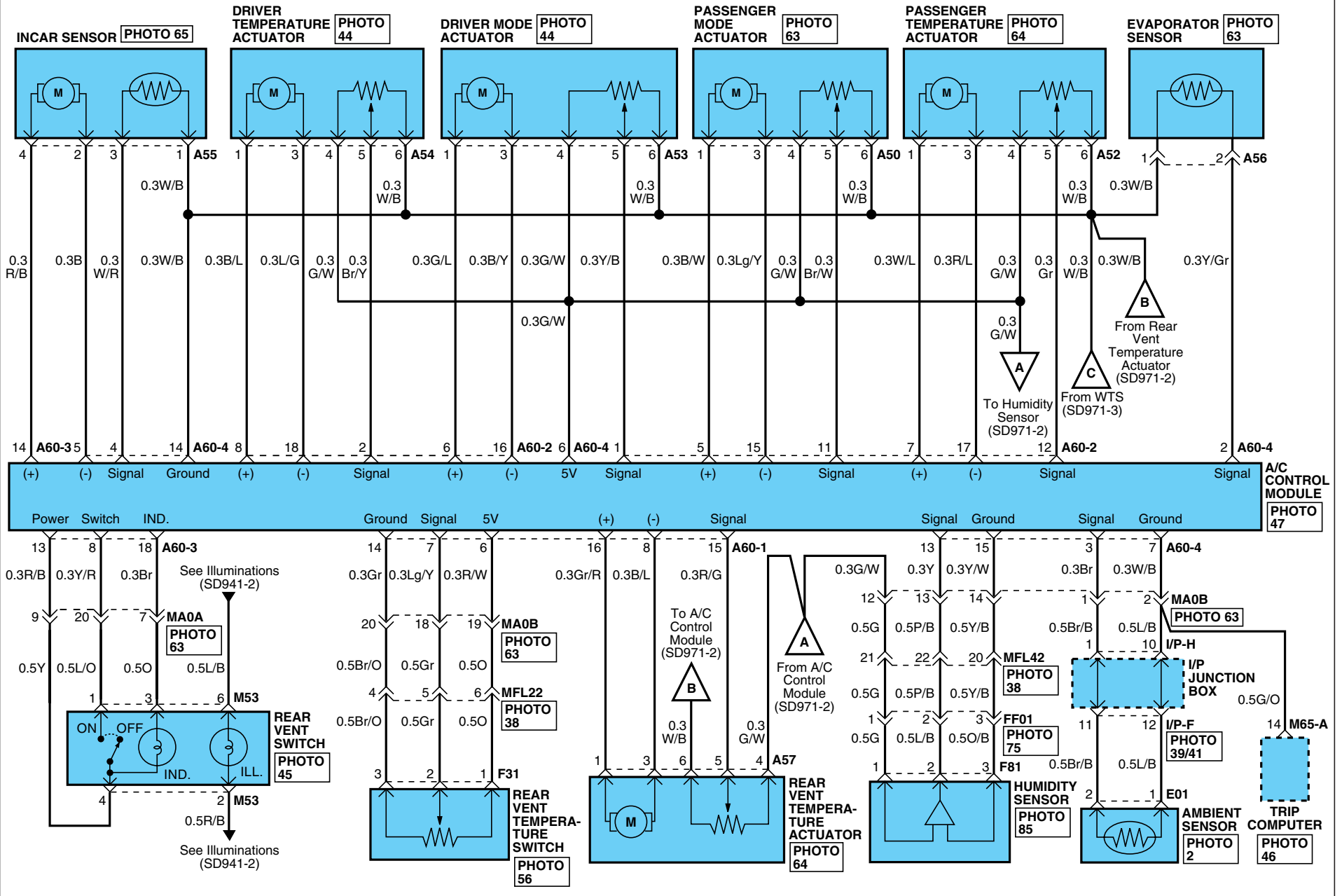

BLOWER & A/C CONTROLS

BLOWER & A/C CONTROLS (3)

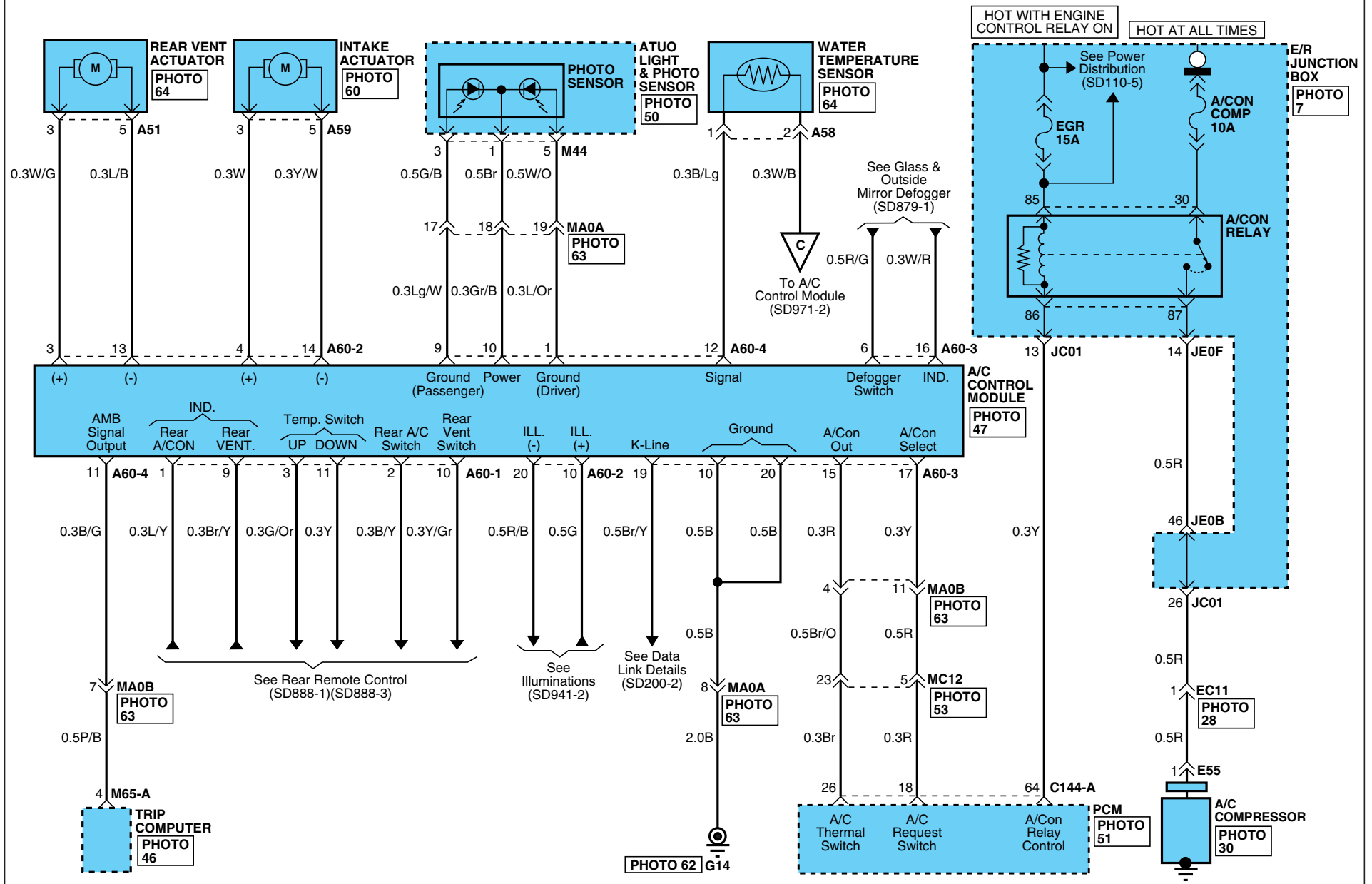

SD971-3



BLOWER & A/C CONTROLS

BLOWER & A/C CONTROLS (4)

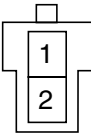
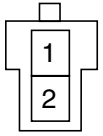
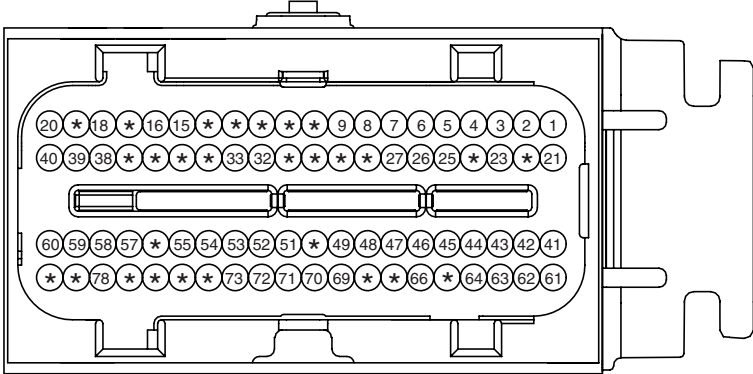
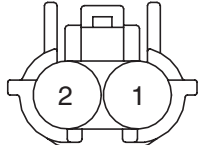
SD971-4

<p>A50</p> <table border="1"> <tr><td>*</td><td>⊗</td><td>1</td></tr> <tr><td>6</td><td>5</td><td>4</td><td>3</td></tr> </table> <p>CR06F044</p>	*	⊗	1	6	5	4	3	<p>A51</p> <table border="1"> <tr><td>*</td><td>⊗</td><td>*</td></tr> <tr><td>*</td><td>5</td><td>*</td><td>3</td></tr> </table> <p>CR06F044</p>	*	⊗	*	*	5	*	3	<p>A52</p> <table border="1"> <tr><td>*</td><td>⊗</td><td>1</td></tr> <tr><td>6</td><td>5</td><td>4</td><td>3</td></tr> </table> <p>CR06F044</p>	*	⊗	1	6	5	4	3	<p>A53</p> <table border="1"> <tr><td>*</td><td>⊗</td><td>1</td></tr> <tr><td>6</td><td>5</td><td>4</td><td>3</td></tr> </table> <p>CR06F044</p>	*	⊗	1	6	5	4	3															
*	⊗	1																																												
6	5	4	3																																											
*	⊗	*																																												
*	5	*	3																																											
*	⊗	1																																												
6	5	4	3																																											
*	⊗	1																																												
6	5	4	3																																											
<p>A54</p> <table border="1"> <tr><td>*</td><td>⊗</td><td>1</td></tr> <tr><td>6</td><td>5</td><td>4</td><td>3</td></tr> </table> <p>CR06F044</p>	*	⊗	1	6	5	4	3	<p>A55</p> <table border="1"> <tr><td>4</td><td>3</td><td>2</td><td>1</td></tr> </table> <p>CR04F007</p>	4	3	2	1	<p>A56</p>  <p>CR02M042</p>	<p>A57</p> <table border="1"> <tr><td>*</td><td>⊗</td><td>1</td></tr> <tr><td>6</td><td>5</td><td>4</td><td>3</td></tr> </table> <p>CR06F044</p>	*	⊗	1	6	5	4	3																									
*	⊗	1																																												
6	5	4	3																																											
4	3	2	1																																											
*	⊗	1																																												
6	5	4	3																																											
<p>A58</p>  <p>CR02M042</p>	<p>A59</p> <table border="1"> <tr><td>*</td><td>⊗</td><td>*</td></tr> <tr><td>*</td><td>5</td><td>*</td><td>3</td></tr> </table> <p>CR06F044</p>	*	⊗	*	*	5	*	3	<p>A60-1</p> <table border="1"> <tr><td>8</td><td>7</td><td>6</td><td>*</td><td>*</td><td>3</td><td>2</td><td>1</td></tr> <tr><td>16</td><td>15</td><td>14</td><td>*</td><td>*</td><td>11</td><td>10</td><td>9</td></tr> </table> <p>CR16F024</p>	8	7	6	*	*	3	2	1	16	15	14	*	*	11	10	9	<p>A60-2</p> <table border="1"> <tr><td>10</td><td>*</td><td>8</td><td>7</td><td>6</td><td>5</td><td>4</td><td>3</td><td>2</td><td>1</td></tr> <tr><td>20</td><td>*</td><td>18</td><td>17</td><td>16</td><td>15</td><td>14</td><td>13</td><td>12</td><td>11</td></tr> </table> <p>CR20F016</p>	10	*	8	7	6	5	4	3	2	1	20	*	18	17	16	15	14	13	12	11
*	⊗	*																																												
*	5	*	3																																											
8	7	6	*	*	3	2	1																																							
16	15	14	*	*	11	10	9																																							
10	*	8	7	6	5	4	3	2	1																																					
20	*	18	17	16	15	14	13	12	11																																					
<p>A60-3</p> <table border="1"> <tr><td>10</td><td>*</td><td>8</td><td>7</td><td>6</td><td>*</td><td>4</td><td>3</td><td>2</td><td>1</td></tr> <tr><td>20</td><td>19</td><td>18</td><td>17</td><td>16</td><td>15</td><td>14</td><td>13</td><td>12</td><td>*</td></tr> </table> <p>CR20F016</p>	10	*	8	7	6	*	4	3	2	1	20	19	18	17	16	15	14	13	12	*	<p>A60-4</p> <table border="1"> <tr><td>*</td><td>7</td><td>6</td><td>5</td><td>4</td><td>3</td><td>2</td><td>1</td></tr> <tr><td>16</td><td>15</td><td>14</td><td>13</td><td>12</td><td>11</td><td>10</td><td>9</td></tr> </table> <p>CR16F024</p>	*	7	6	5	4	3	2	1	16	15	14	13	12	11	10	9	<p>C144-A</p>  <p>PKD_ECU_80F_GR_3</p>								
10	*	8	7	6	*	4	3	2	1																																					
20	19	18	17	16	15	14	13	12	*																																					
*	7	6	5	4	3	2	1																																							
16	15	14	13	12	11	10	9																																							
<p>E01</p>  <p>KET_SWP_02F_B</p>	<p>E55</p>  <p>KUM_NMWP_01F_B</p>																																													

BLOWER & A/C CONTROLS

BLOWER & A/C CONTROLS (5)

SD971-5

F31

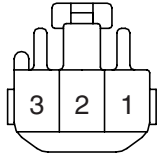

KET_090I1_03F_W

F81

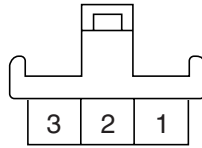

KET_070_03F

M06

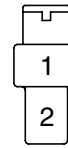

KET_250_02F_W

M07

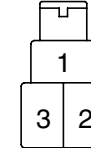

KUM_DSD_03F_B

M44

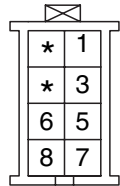

KET_030_08F_GR

M53

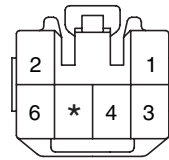

KET_090I1_06F_L

M65-A

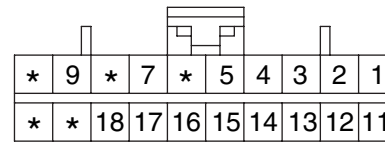

AMP_040M2_20F_B

BLANK

BLOWER & A/C CONTROLS

BLOWER & A/C CONTROLS (6)

SD971-6

MEMO

AIR PURIFIER SYSTEM (1)

SD976-1

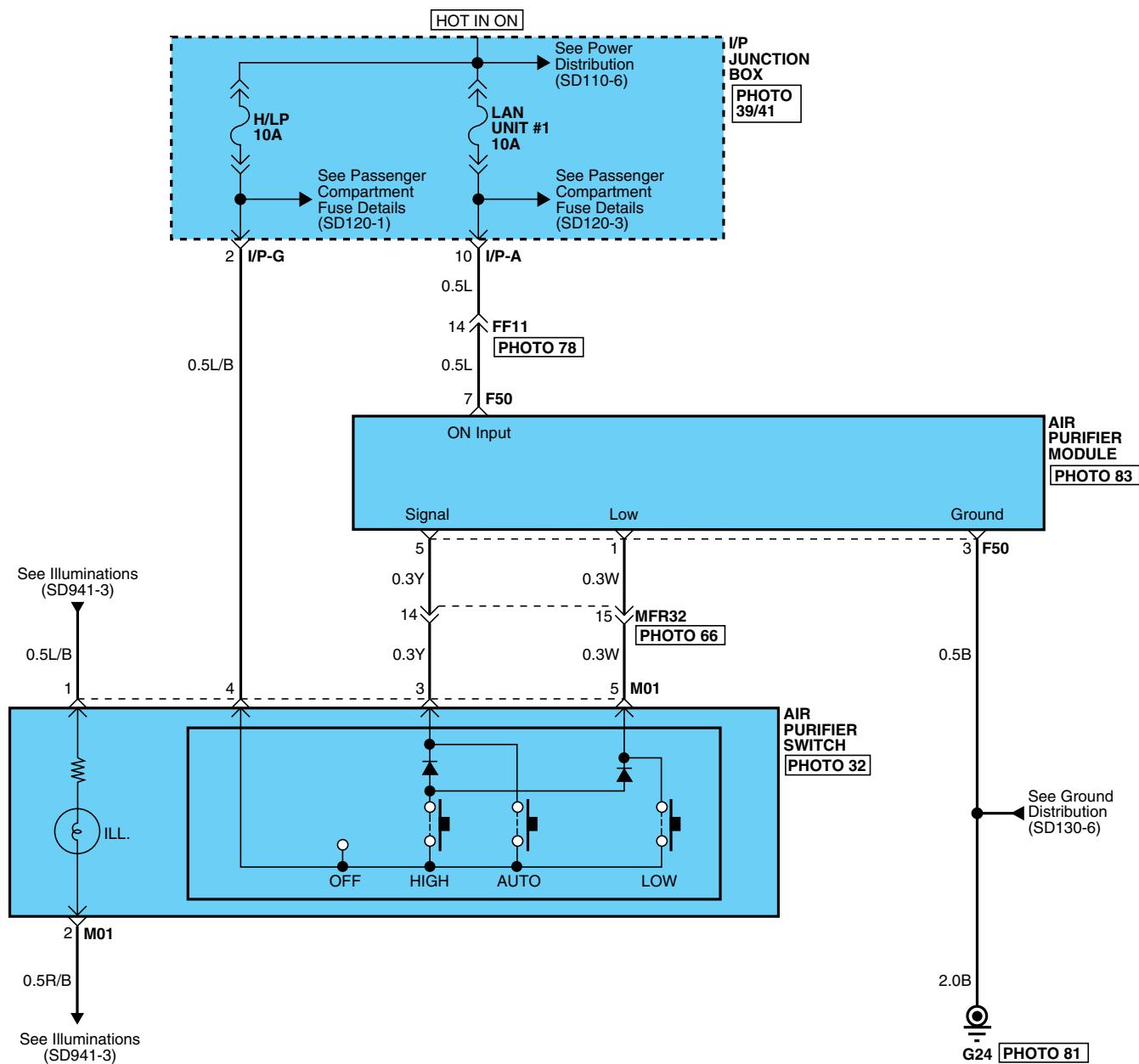

AIR PURIFIER SYSTEM

AIR PURIFIER SYSTEM (2)

SD976-2

F50

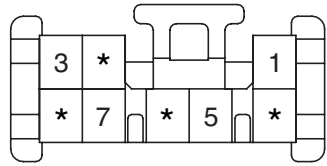

KET_070II_08F_W_PCB

M01

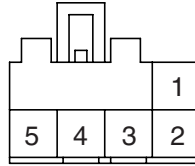

KUM_CDR_05F_L

BLANK

BLANK

WIPER & WASHER

WIPER & WASHER (3)

SD981-3

C116



KUM_NMWP_06F_B

E33

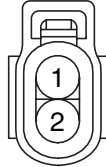

KET_090WP_02F_W_SIDE

M05-B

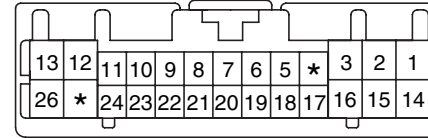

KET_0407_26F_W

M05-C

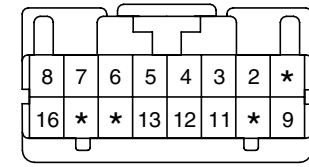

KET_0407_16F_W

M05-D

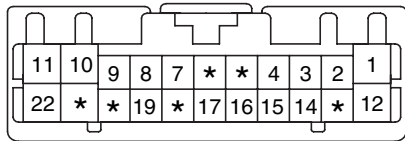

KET_0407_22F_W

M42

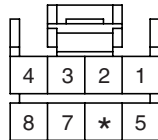

AMP_040M1_08F_B

R64

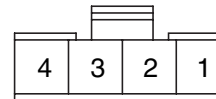

MLX_FIT_04F_B

BLANK

COMPONENT LOCATIONS (1)

CL-1

PHOTO.1

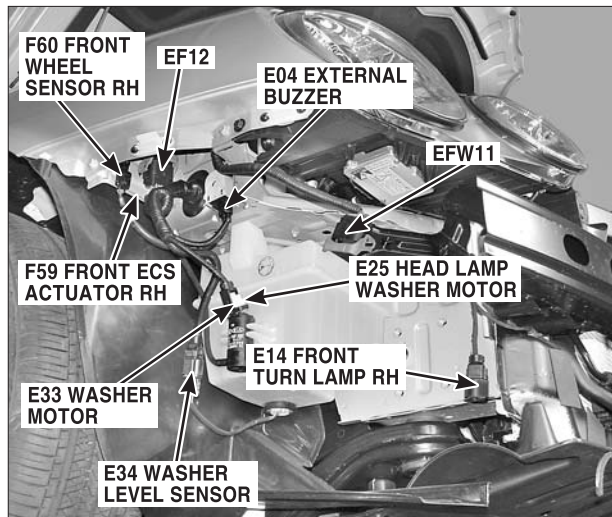

PHOTO.2

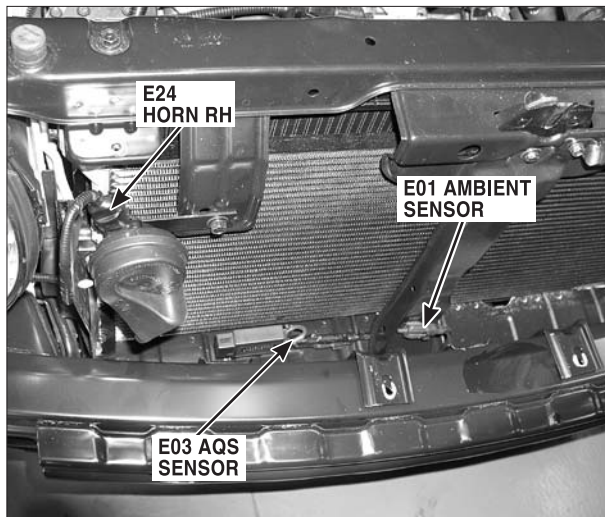

PHOTO.3



PHOTO.4

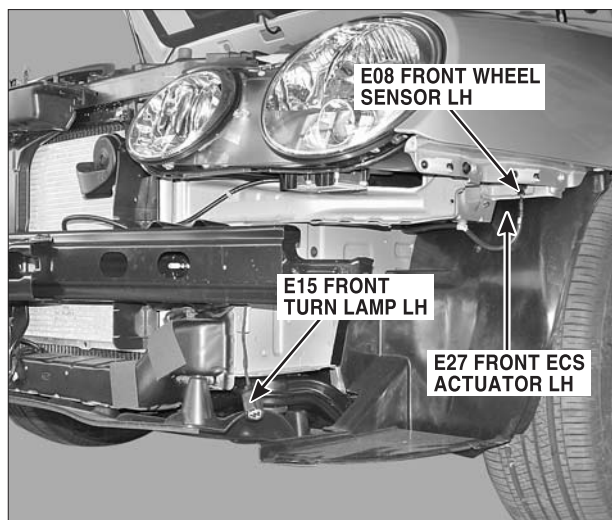

PHOTO.5

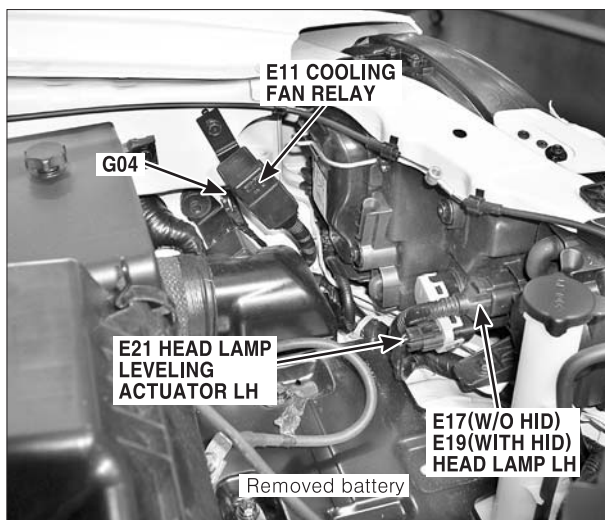
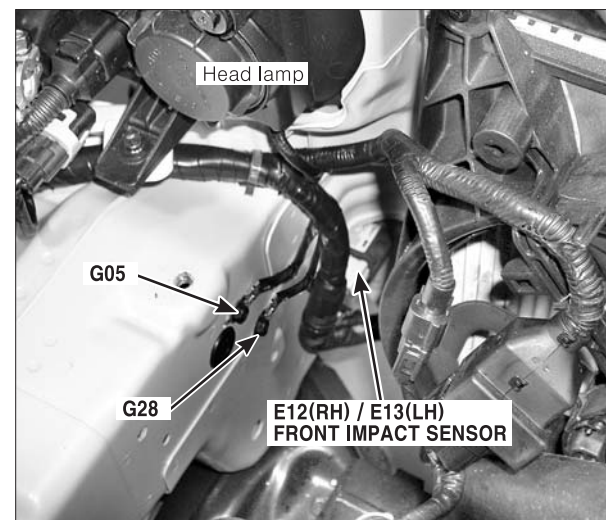

PHOTO.6



COMPONENT LOCATIONS

COMPONENT LOCATIONS (2)

CL-2

PHOTO.7

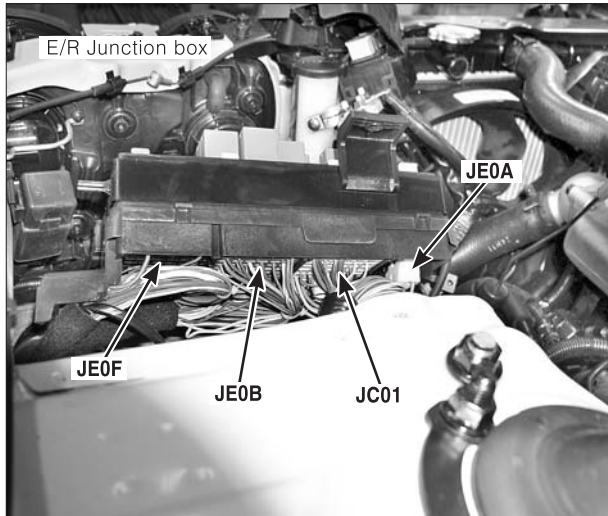

PHOTO.8

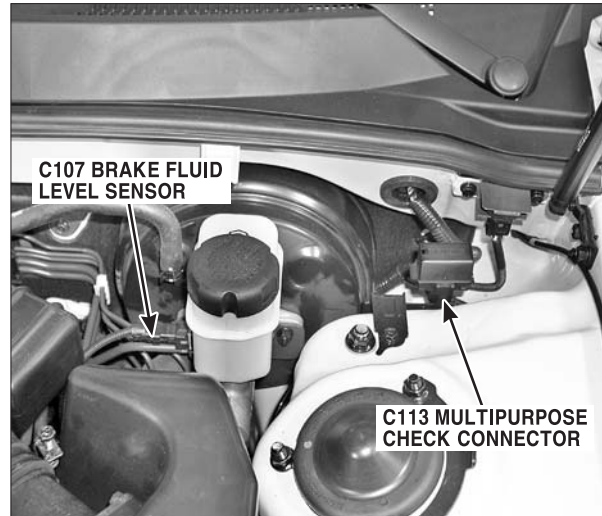

PHOTO.9

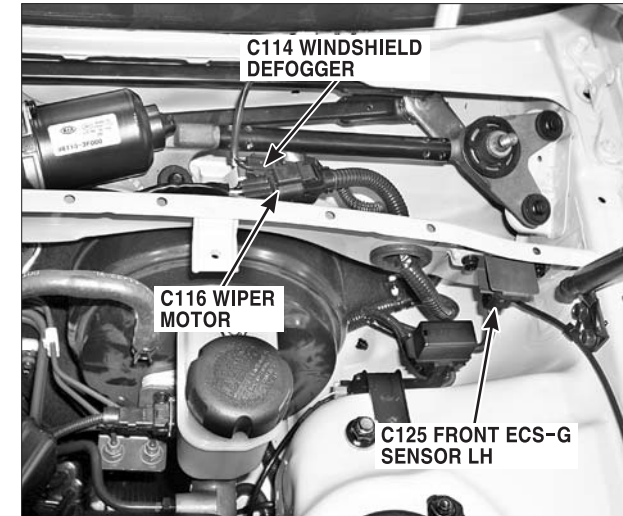

PHOTO.10



PHOTO.11

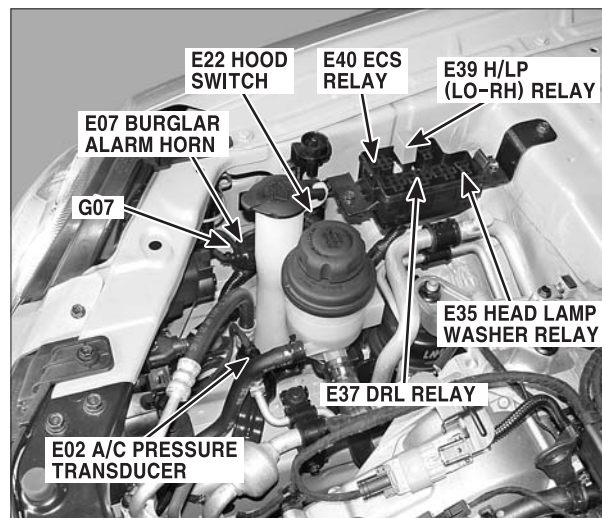
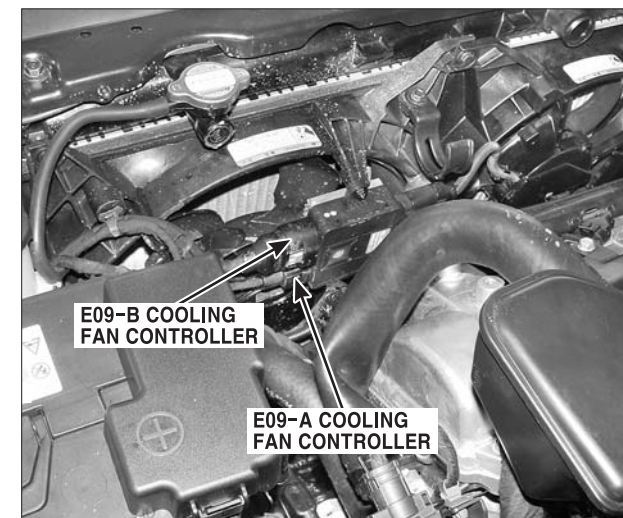

PHOTO.12



COMPONENT LOCATIONS

COMPONENT LOCATIONS (3)

CL-3

PHOTO.13

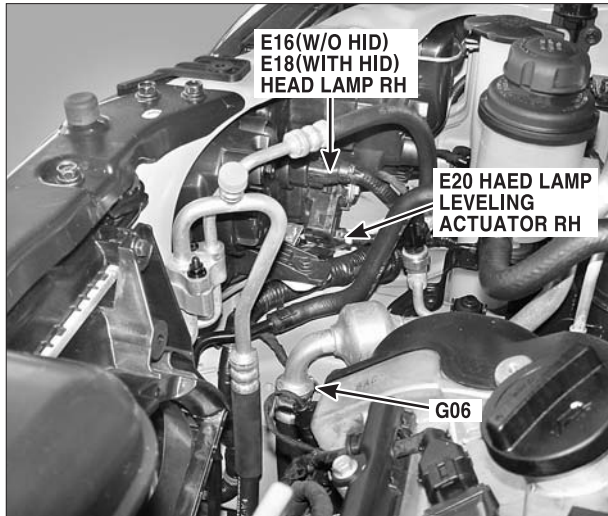

PHOTO.14

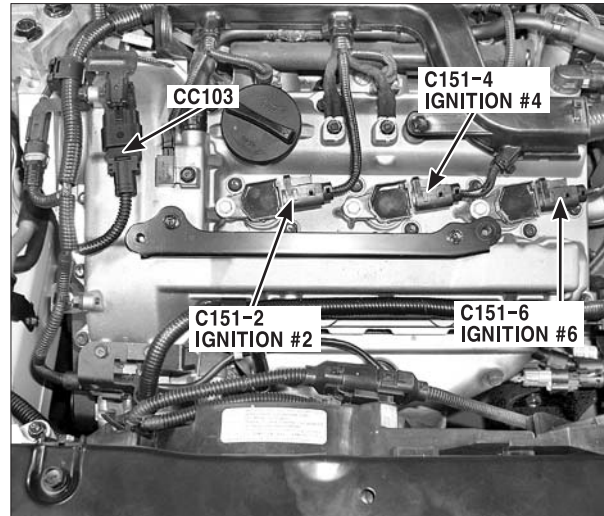

PHOTO.15

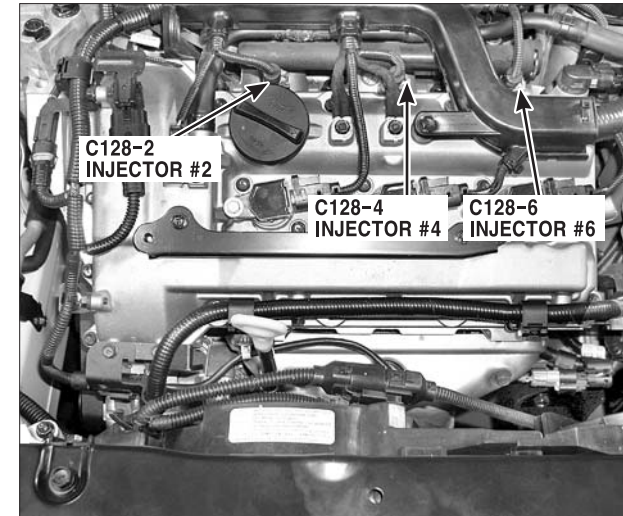

PHOTO.16

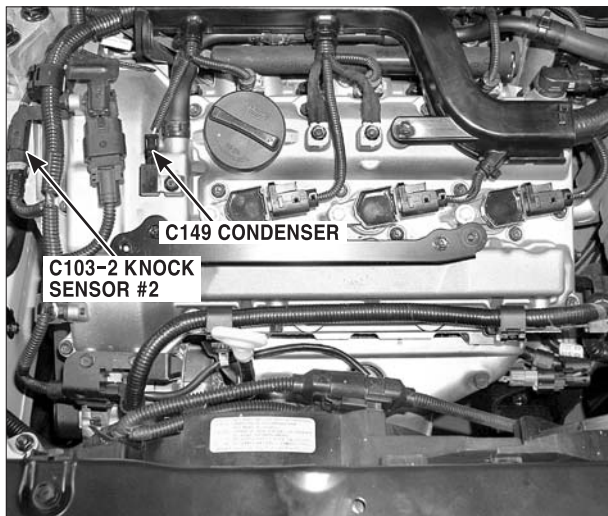

PHOTO.17

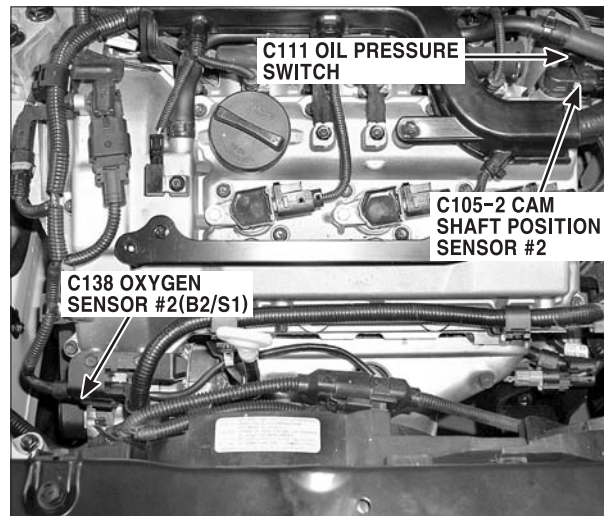

PHOTO.18



COMPONENT LOCATIONS

COMPONENT LOCATIONS (4)

CL-4

PHOTO.19

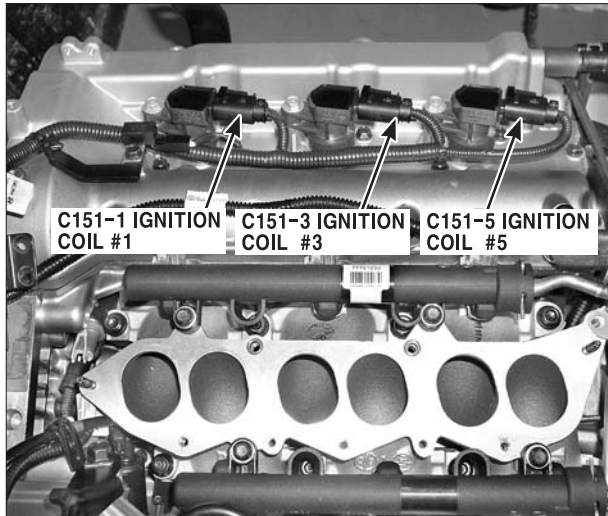

PHOTO.20

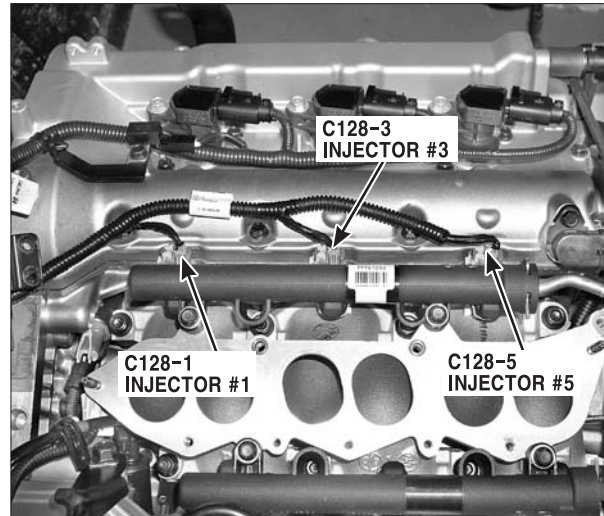

PHOTO.21

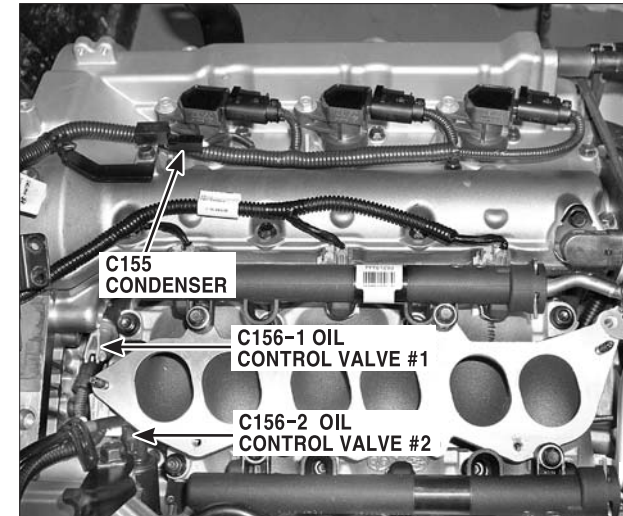

PHOTO.22

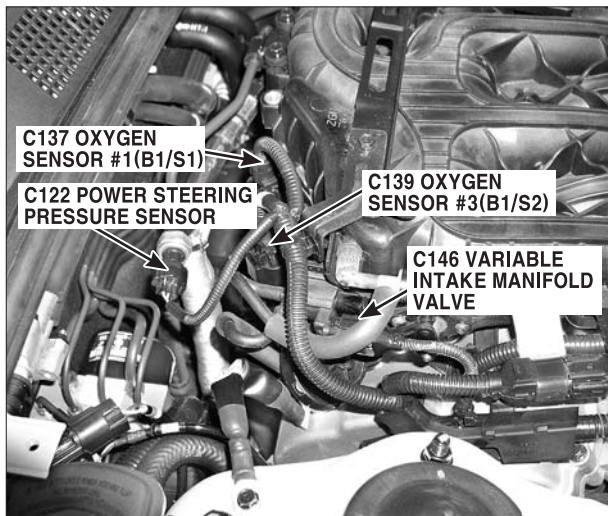

PHOTO.23

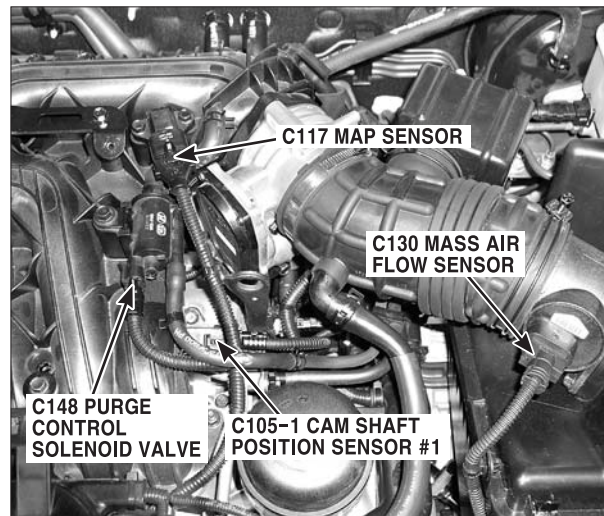
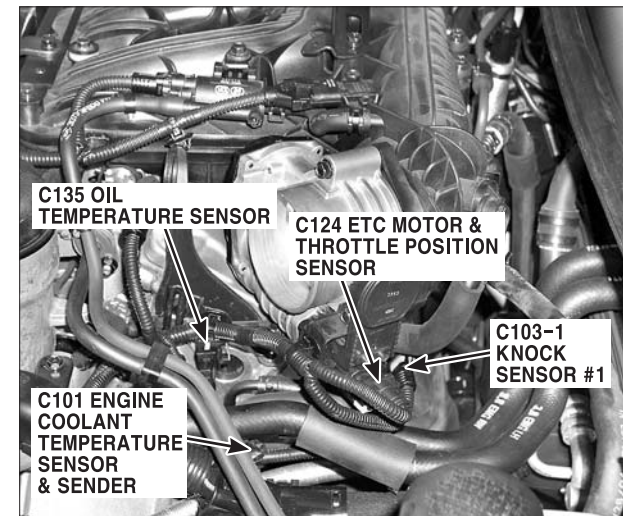

PHOTO.24



COMPONENT LOCATIONS

COMPONENT LOCATIONS (5)

CL-5

PHOTO.25

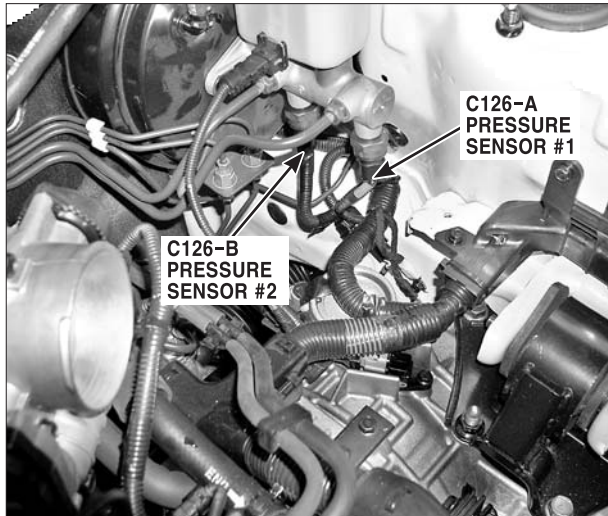

PHOTO.26

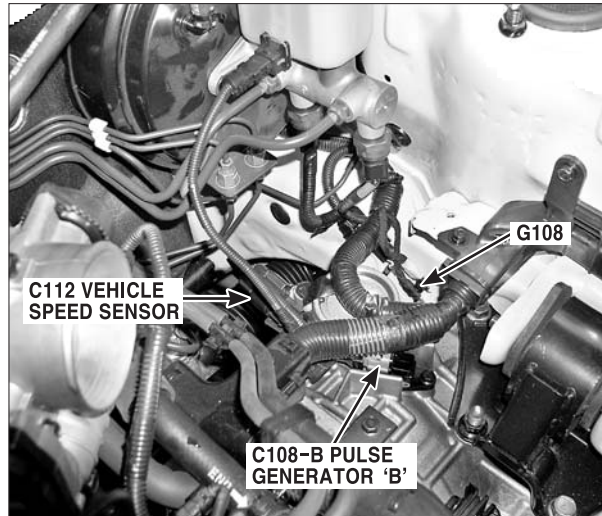

PHOTO.27

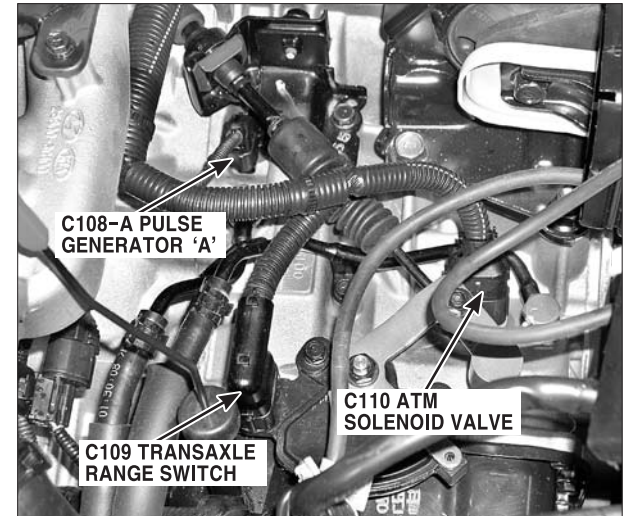

PHOTO.28

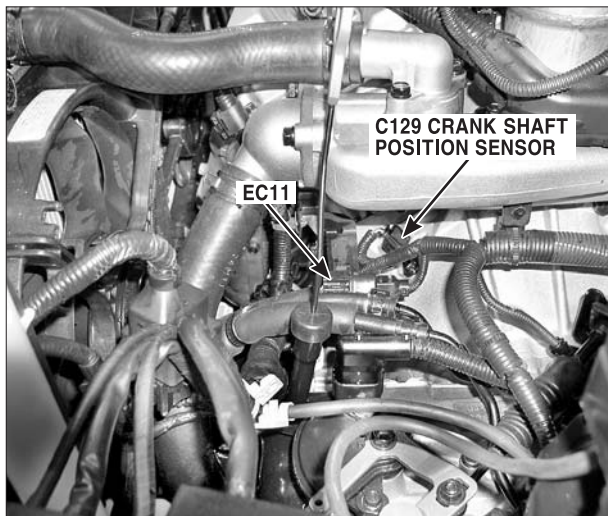
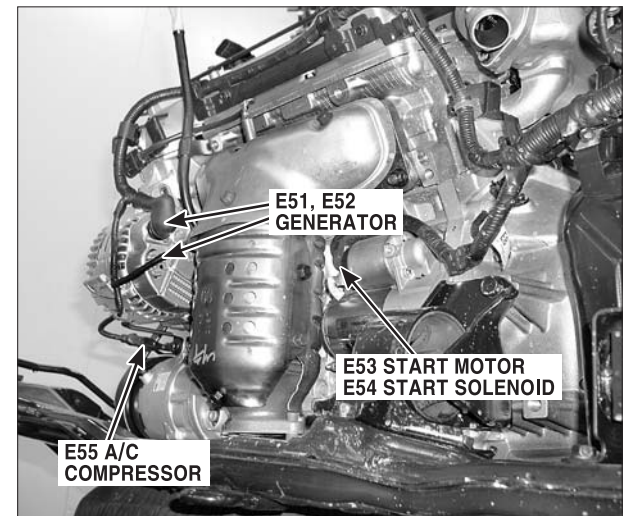

PHOTO.29



PHOTO.30



COMPONENT LOCATIONS

COMPONENT LOCATIONS (6)

CL-6

PHOTO.31



PHOTO.32

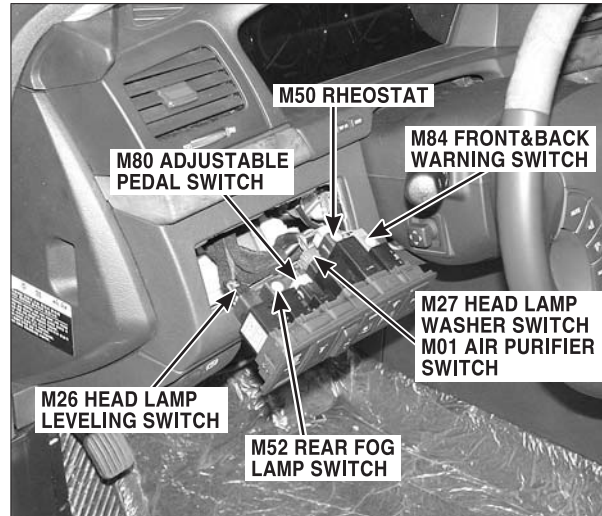

PHOTO.33

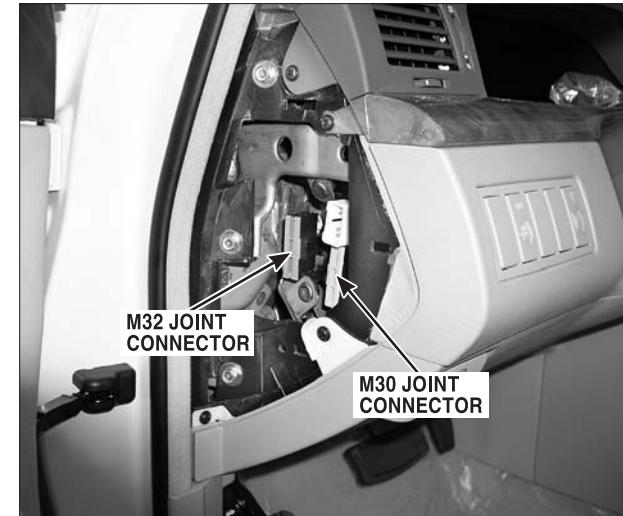

PHOTO.34

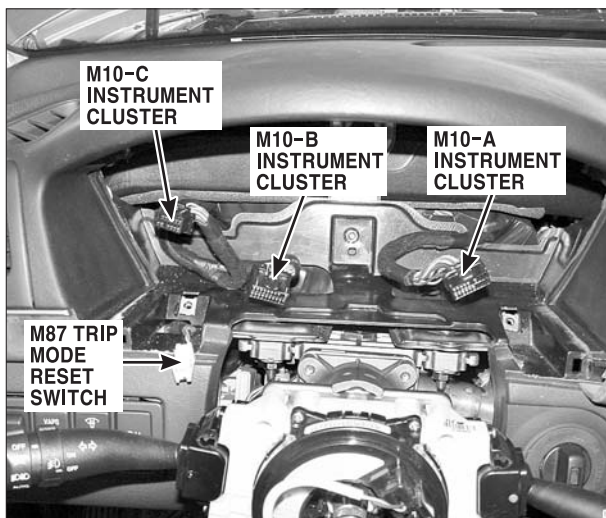

PHOTO.35

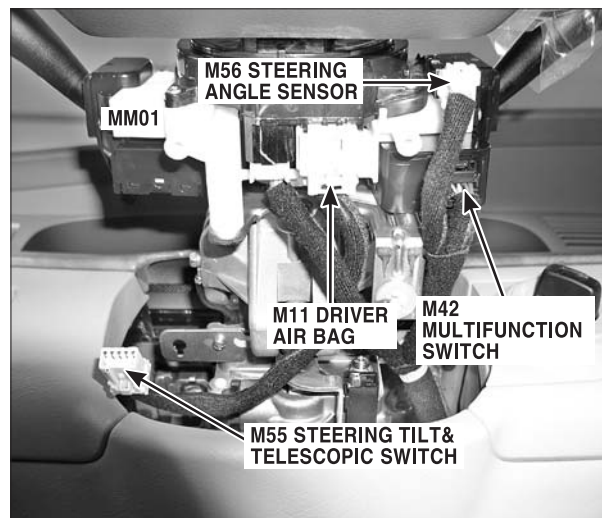
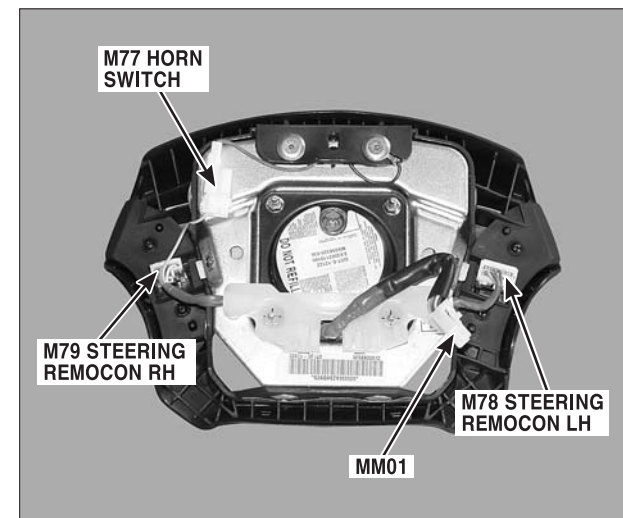

PHOTO.36



COMPONENT LOCATIONS

COMPONENT LOCATIONS (7)

CL-7

PHOTO.37

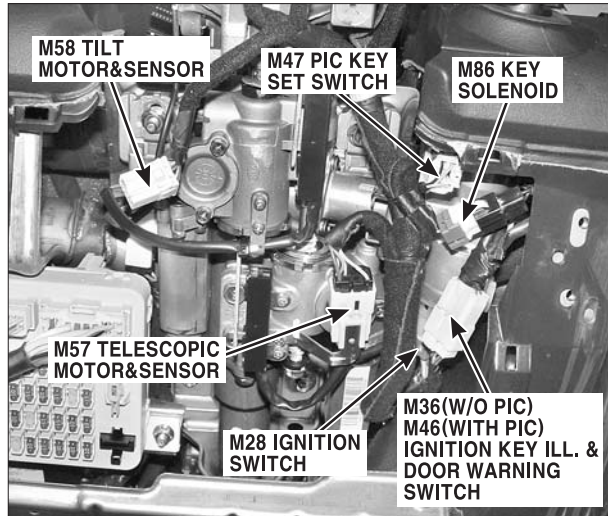

PHOTO.38

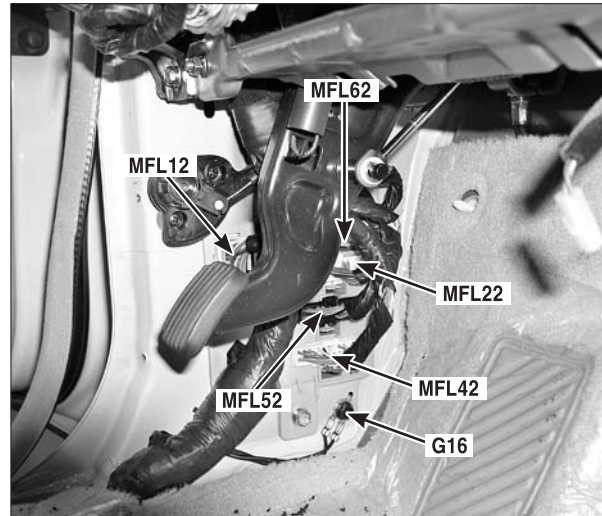

PHOTO.39

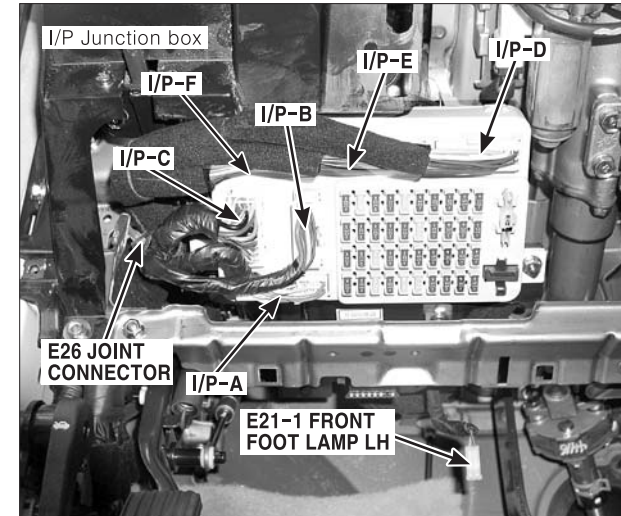

PHOTO.40

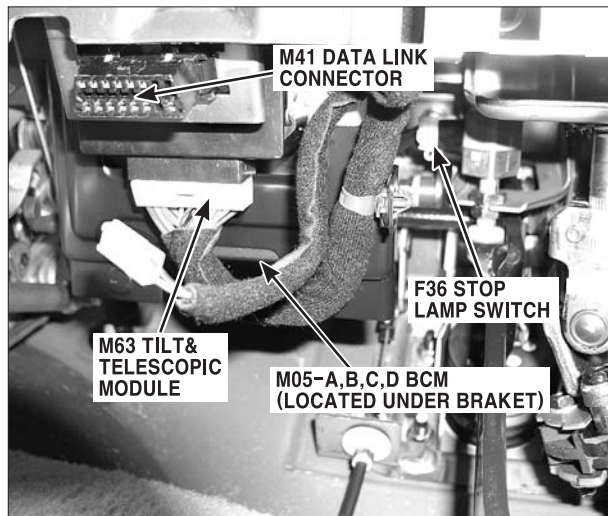

PHOTO.41

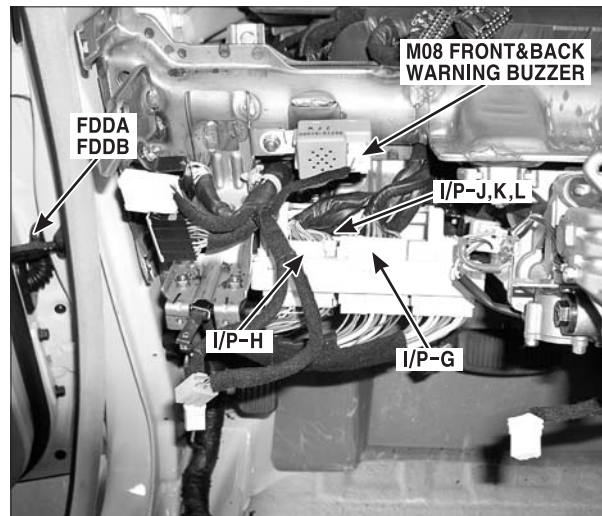
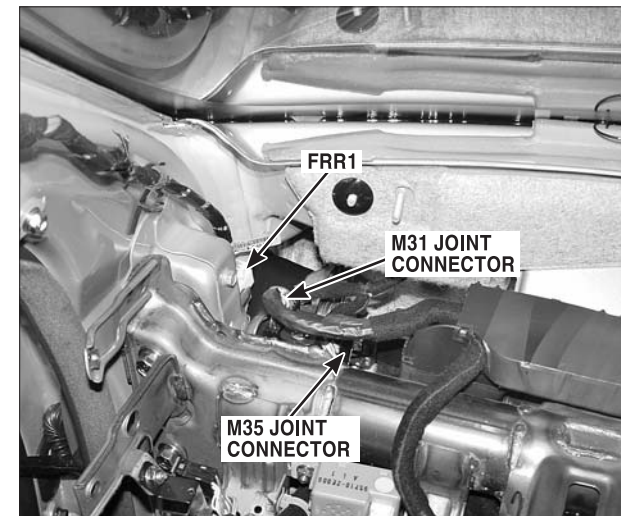

PHOTO.42



COMPONENT LOCATIONS

COMPONENT LOCATIONS (8)

CL-8

PHOTO.43

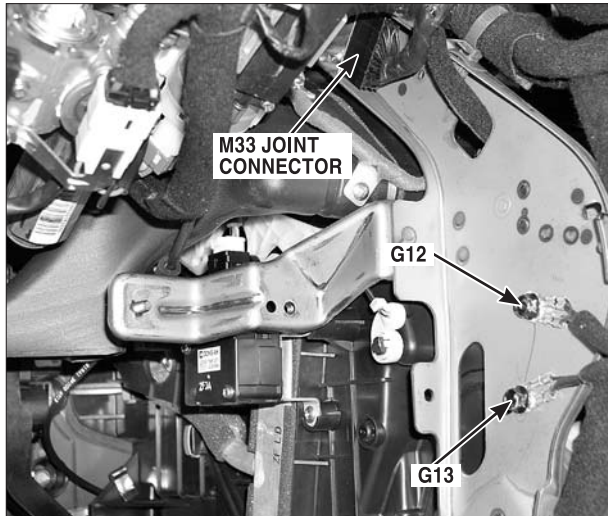

PHOTO.44

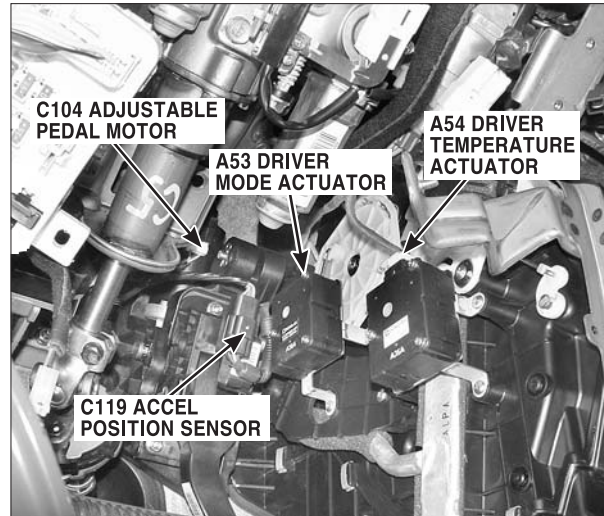

PHOTO.45

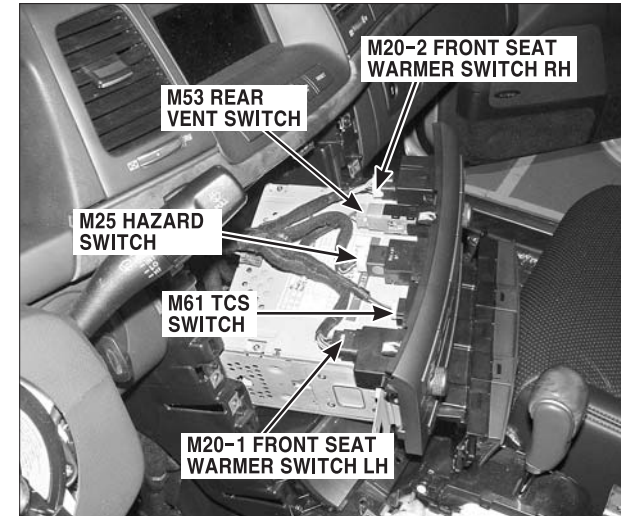

PHOTO.46

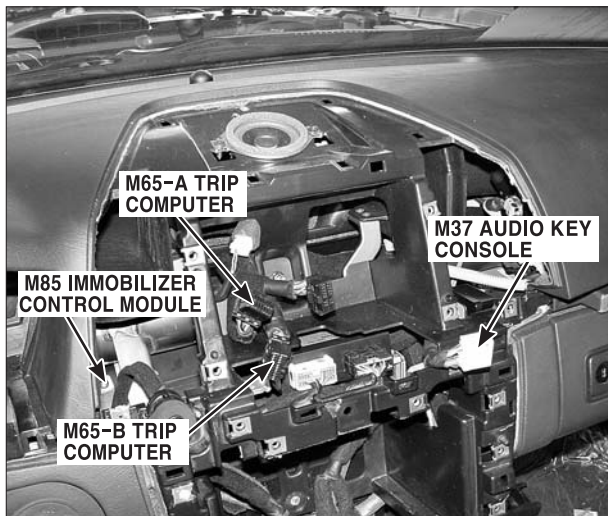

PHOTO.47

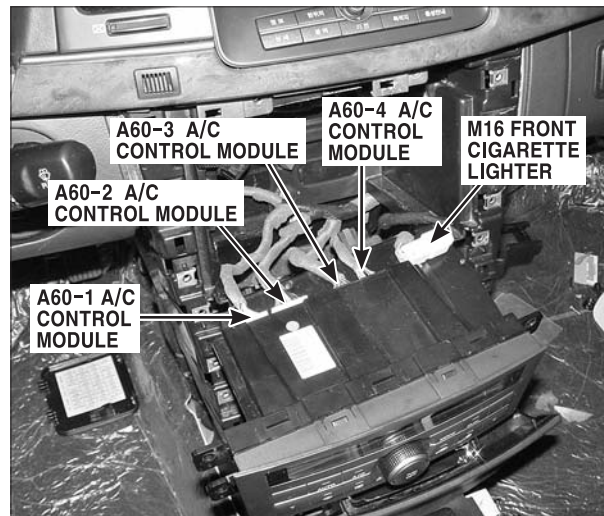

PHOTO.48



COMPONENT LOCATIONS

COMPONENT LOCATIONS (9)

CL-9

PHOTO.49

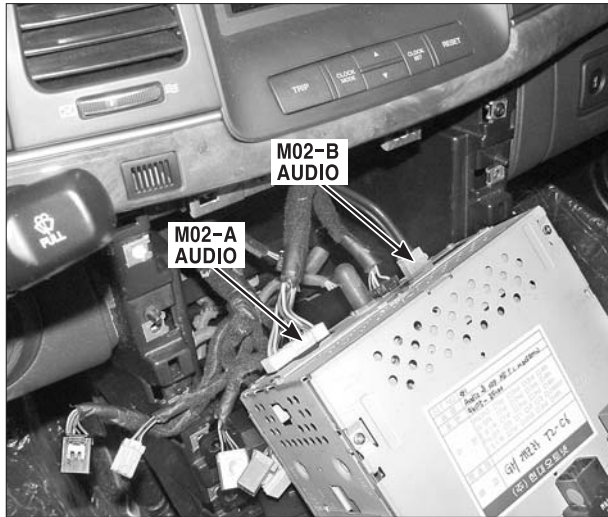

PHOTO.50

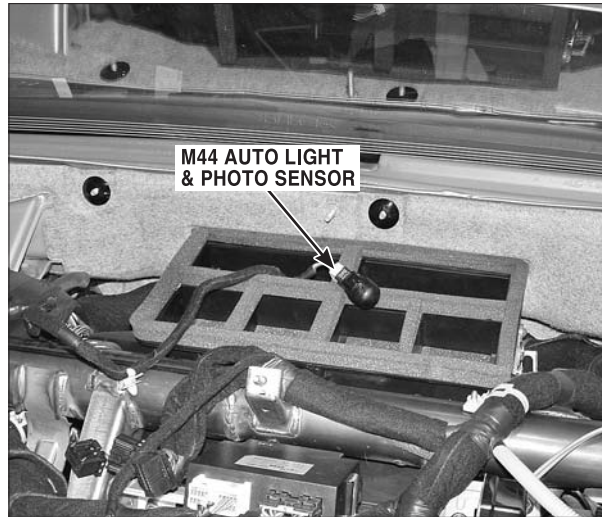

PHOTO.51

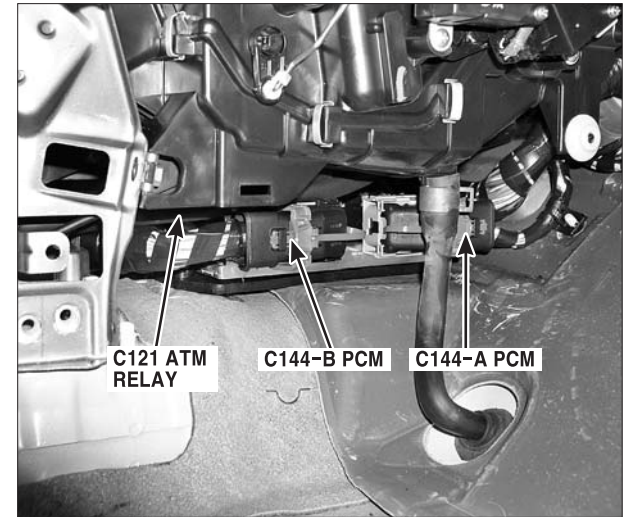

PHOTO.52

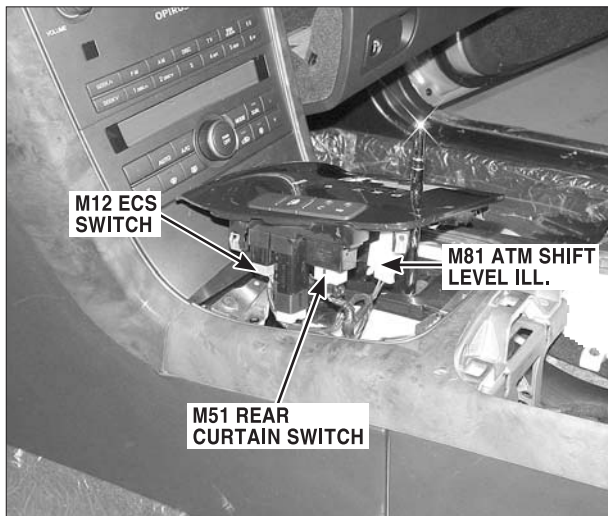

PHOTO.53

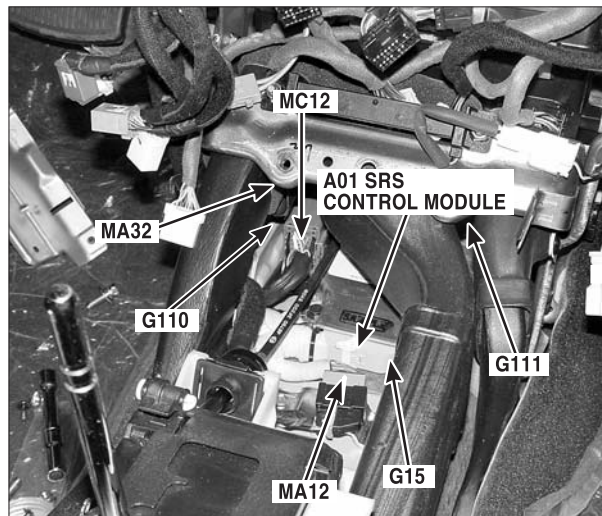
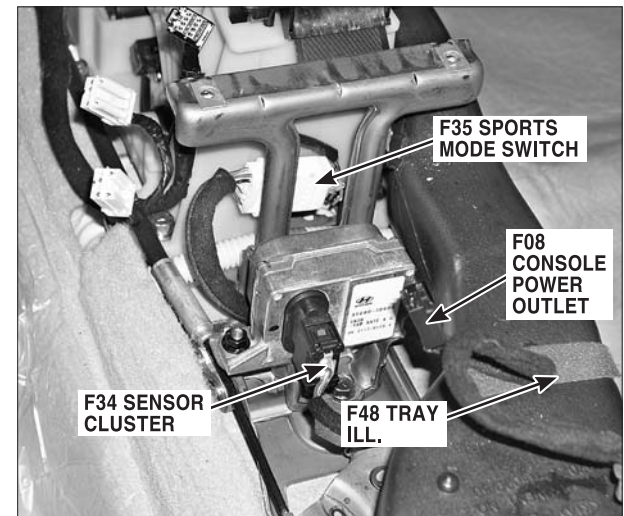

PHOTO.54



COMPONENT LOCATIONS

COMPONENT LOCATIONS (10)

CL-10

PHOTO.55



PHOTO.56

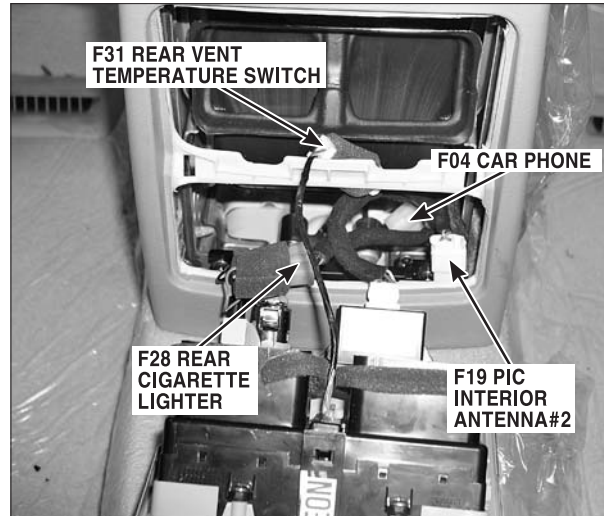

PHOTO.57

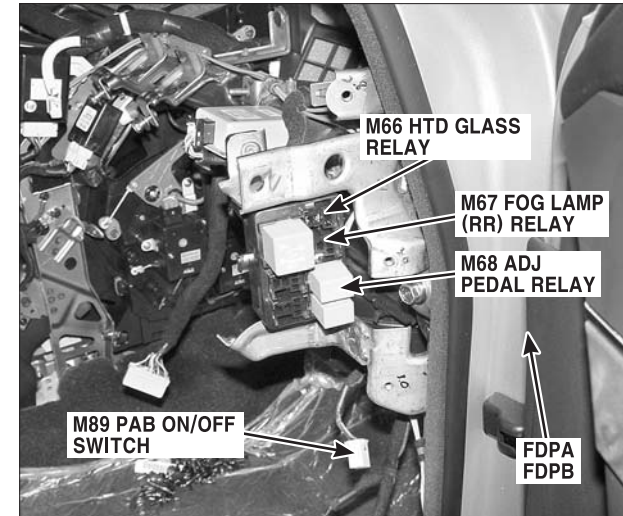

PHOTO.58

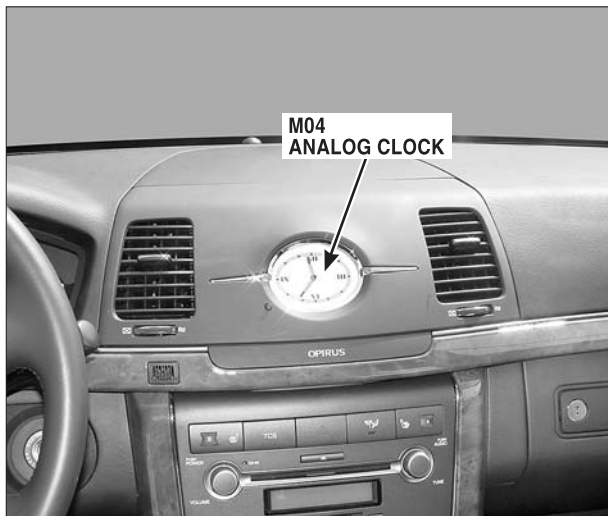

PHOTO.59

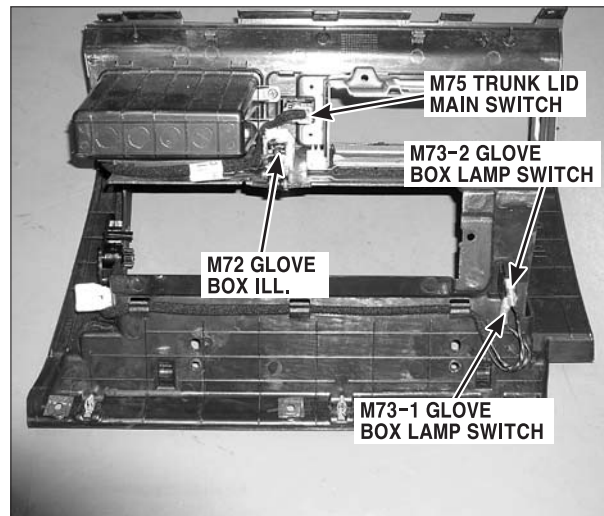
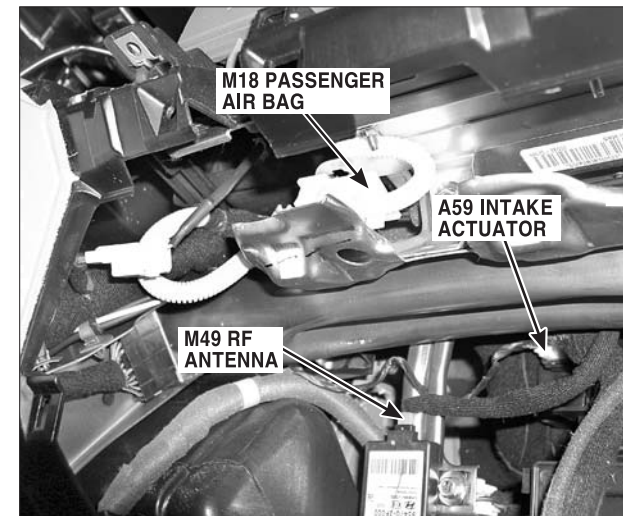

PHOTO.60



COMPONENT LOCATIONS

COMPONENT LOCATIONS (11)

CL-11

PHOTO.61

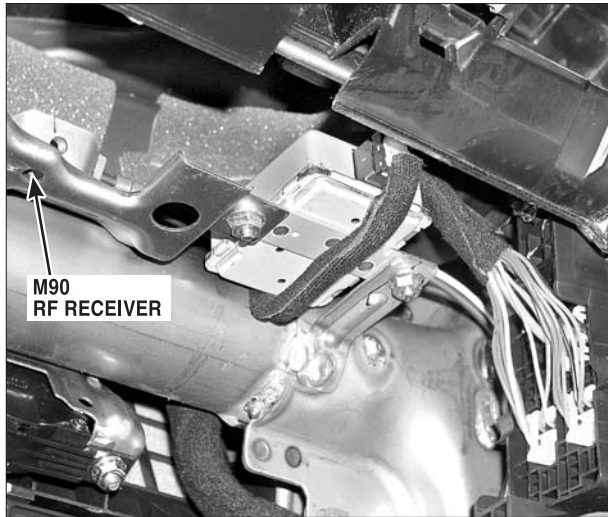

PHOTO.62

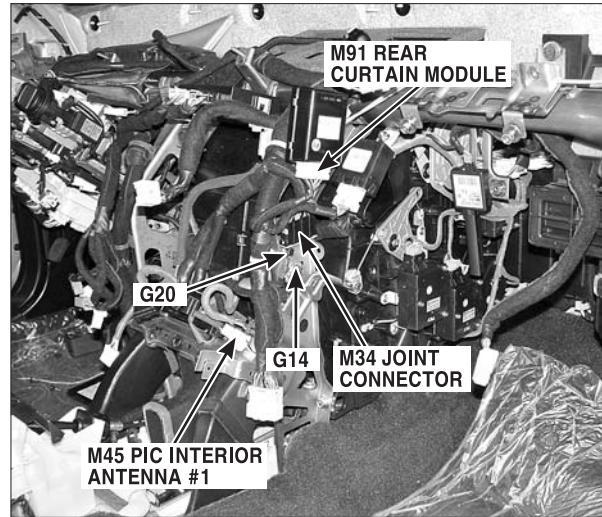

PHOTO.63

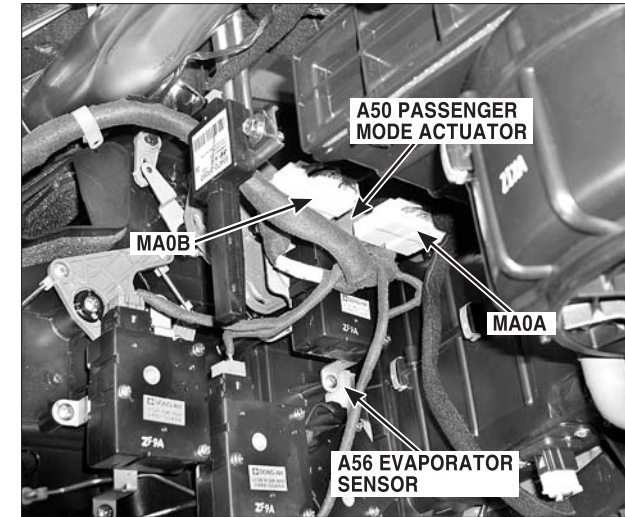

PHOTO.64

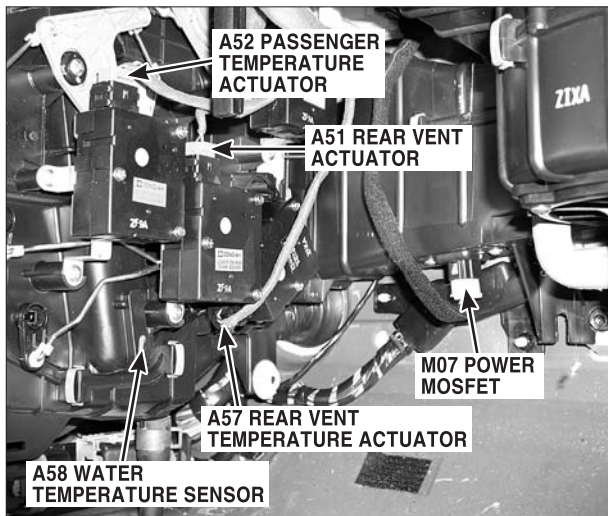
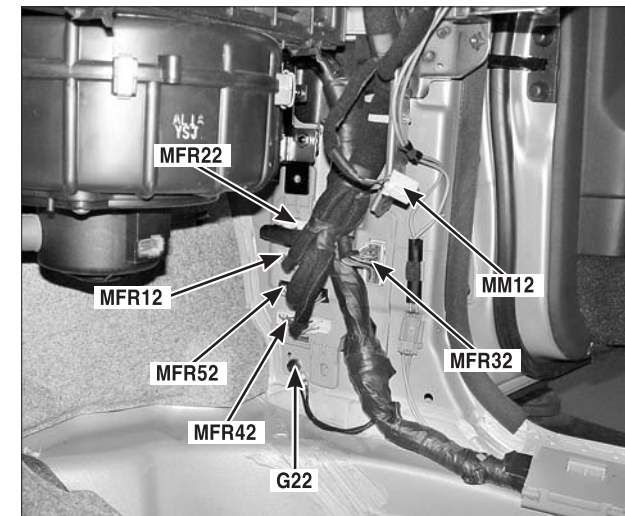

PHOTO.65



PHOTO.66



COMPONENT LOCATIONS

COMPONENT LOCATIONS (12)

CL-12

PHOTO.67

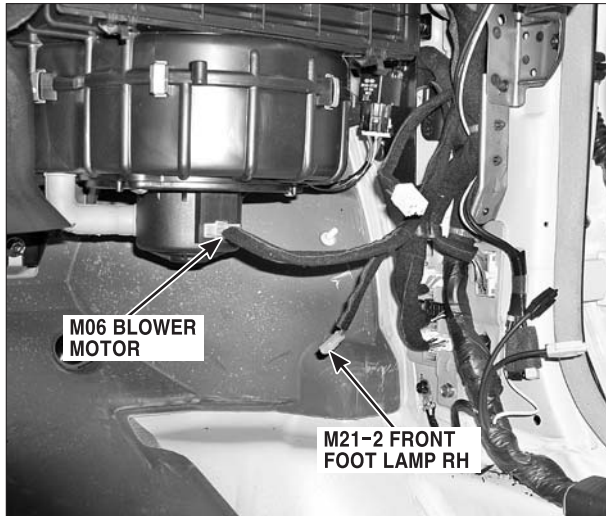

PHOTO.68

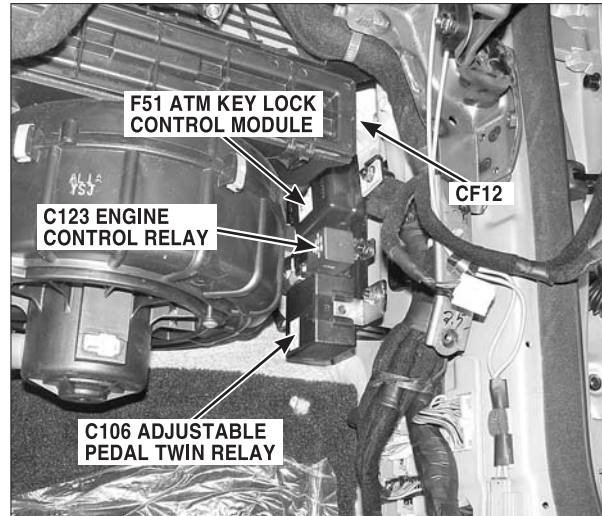

PHOTO.69

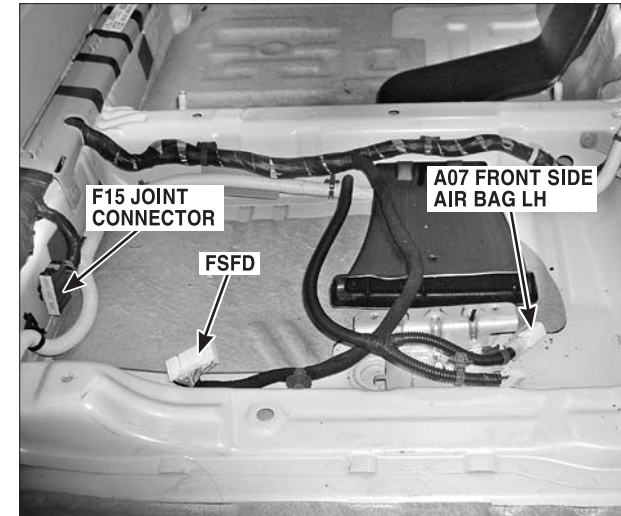

PHOTO.70

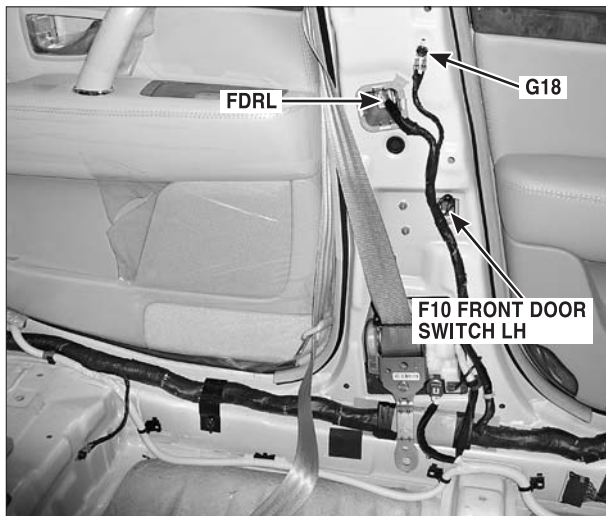

PHOTO.71

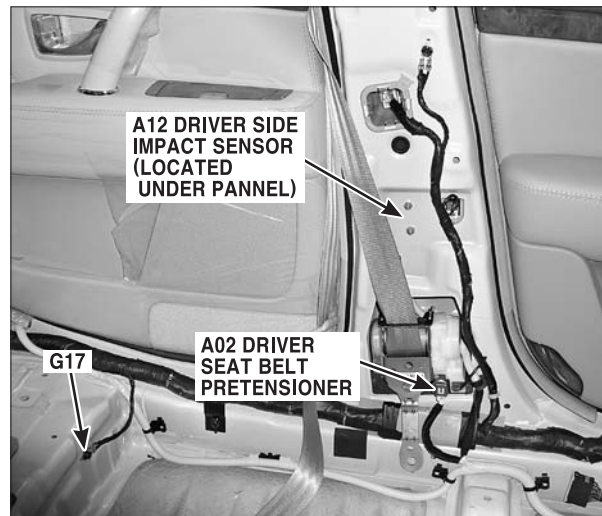

PHOTO.72



COMPONENT LOCATIONS

COMPONENT LOCATIONS (13)

CL-13

PHOTO.73



PHOTO.74

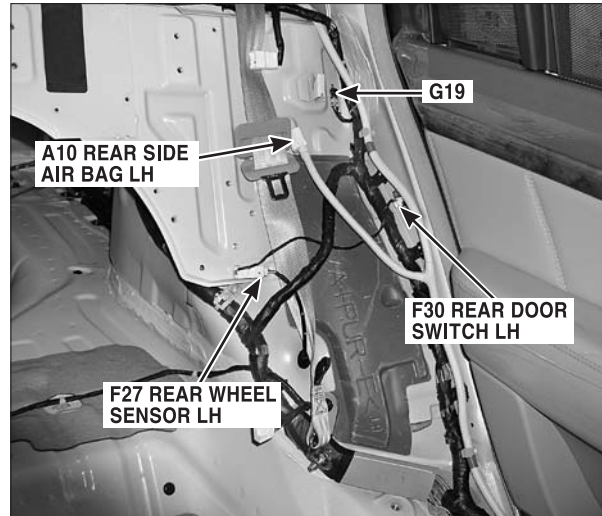

PHOTO.75



PHOTO.76

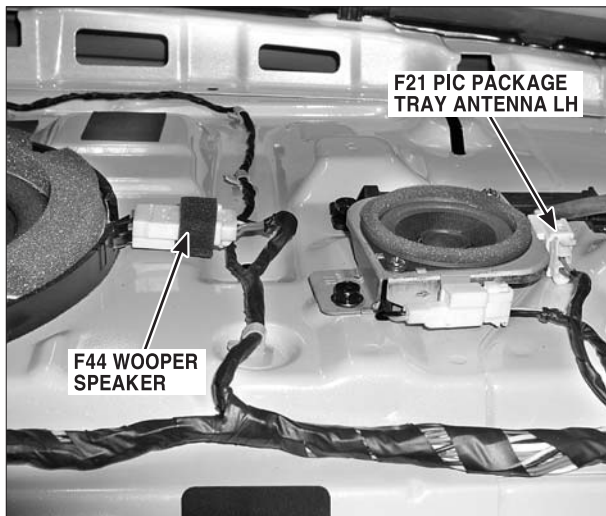

PHOTO.77

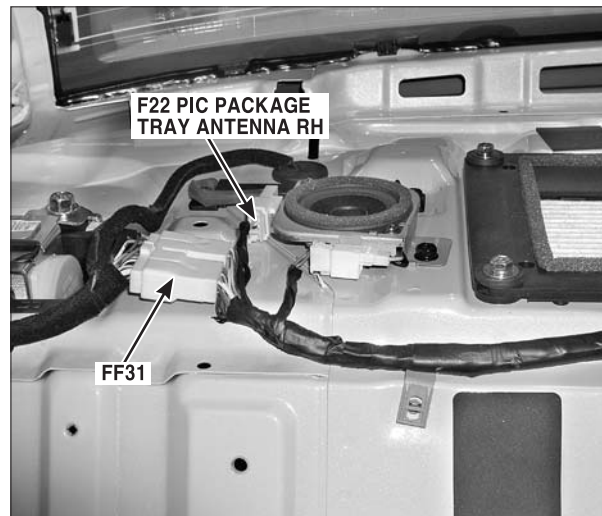
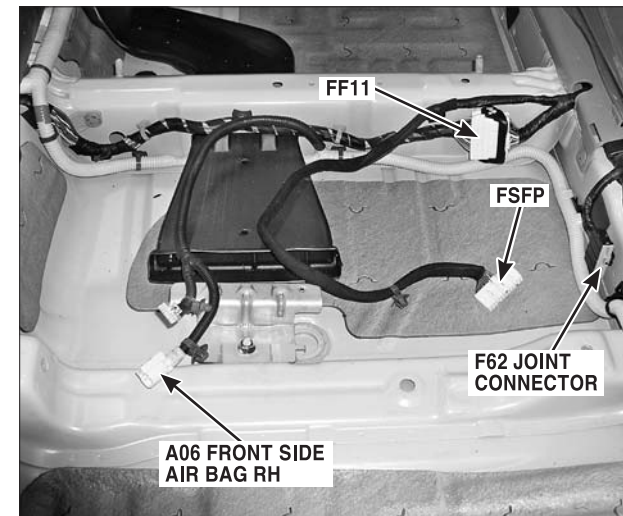

PHOTO.78



COMPONENT LOCATIONS

COMPONENT LOCATIONS (14)

CL-14

PHOTO.79

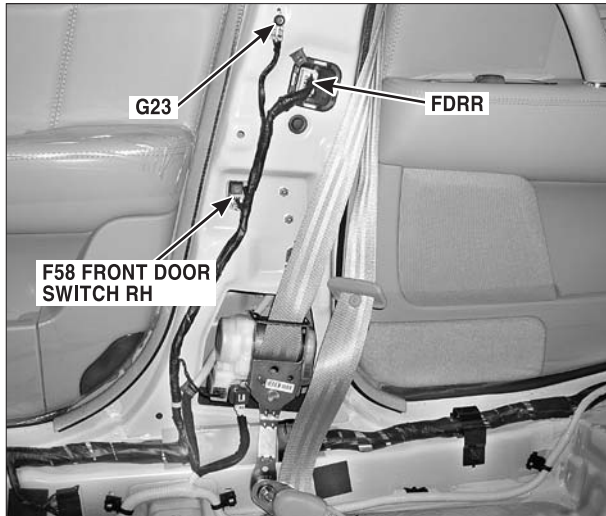

PHOTO.80



PHOTO.81

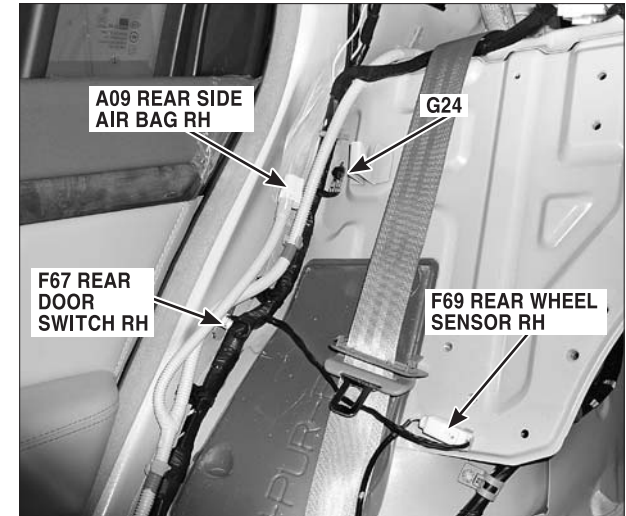

PHOTO.82

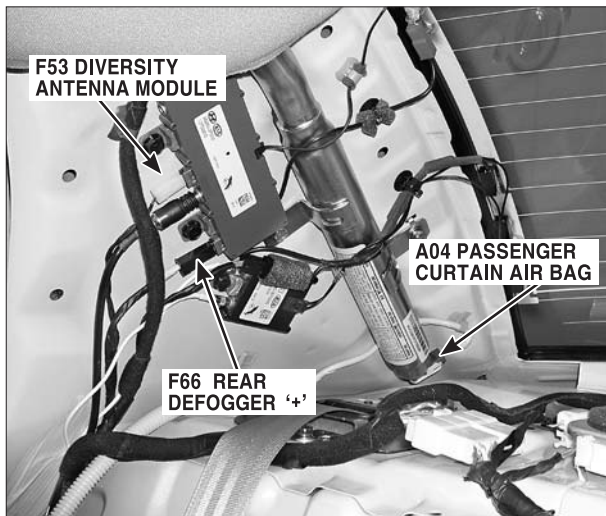

PHOTO.83

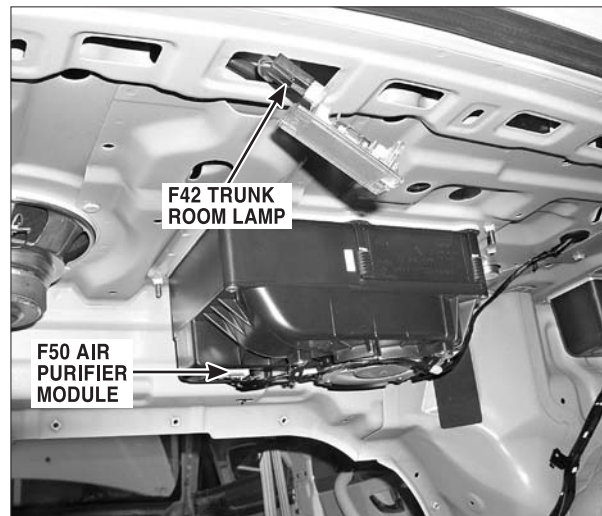
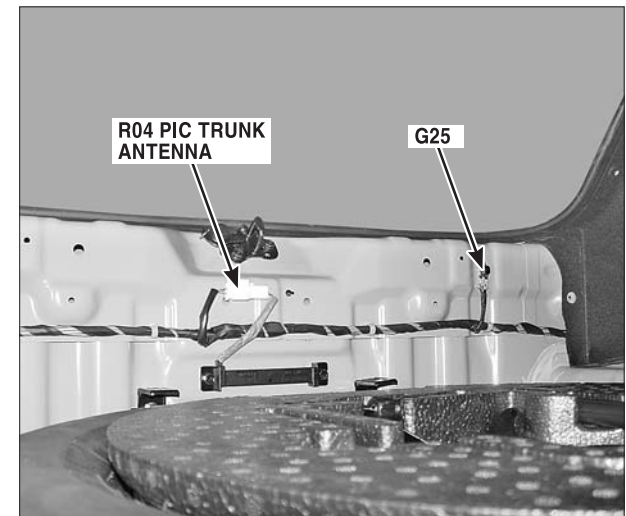

PHOTO.84



COMPONENT LOCATIONS

COMPONENT LOCATIONS (15)

CL-15

PHOTO.85

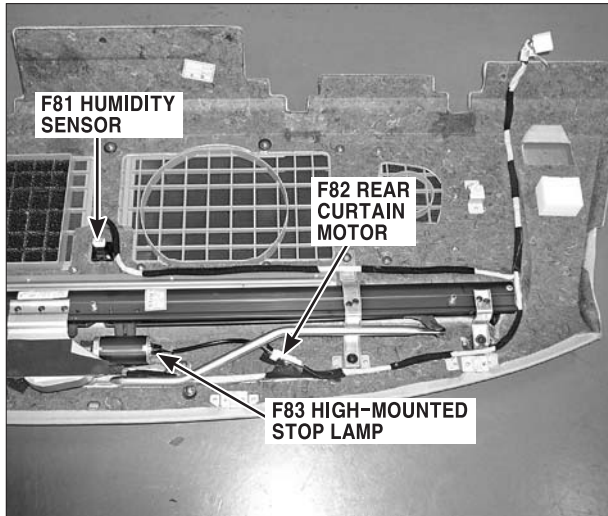

PHOTO.86

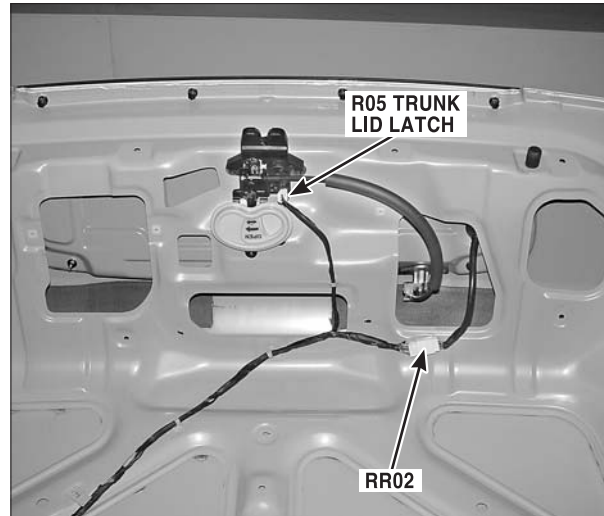

PHOTO.87

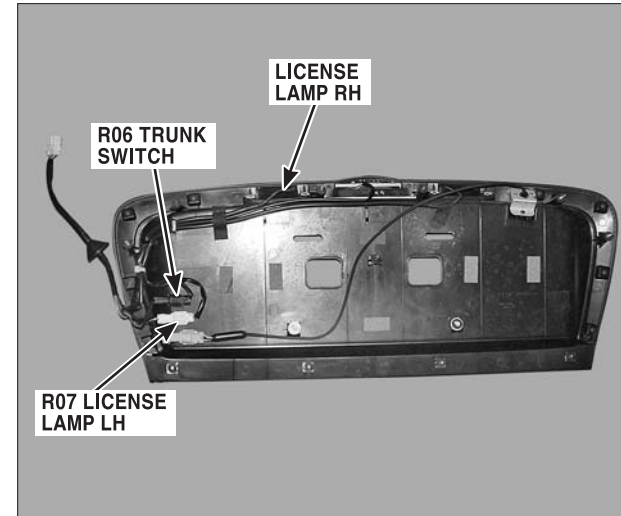

PHOTO.88

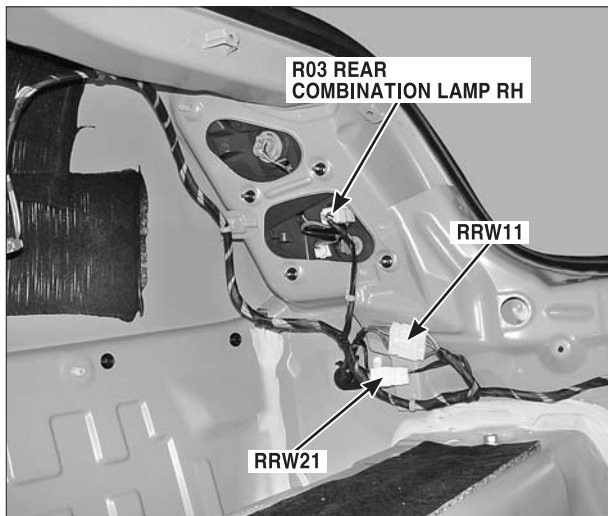

PHOTO.89

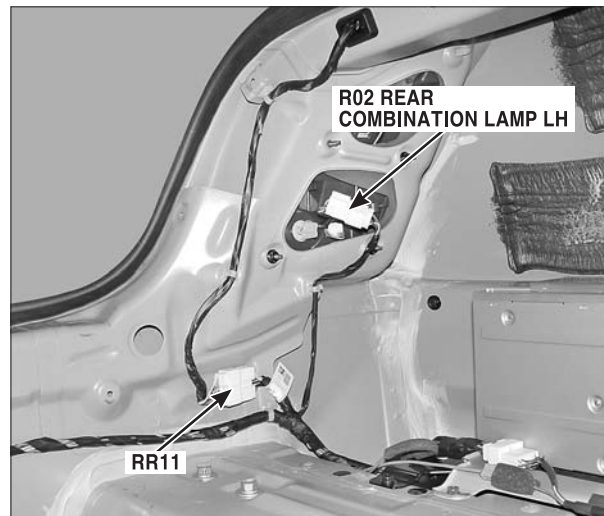
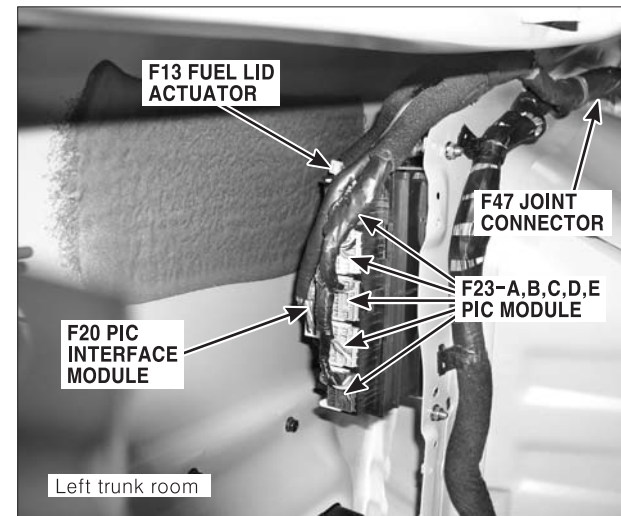

PHOTO.90



COMPONENT LOCATIONS

COMPONENT LOCATIONS (16)

CL-16

PHOTO.91

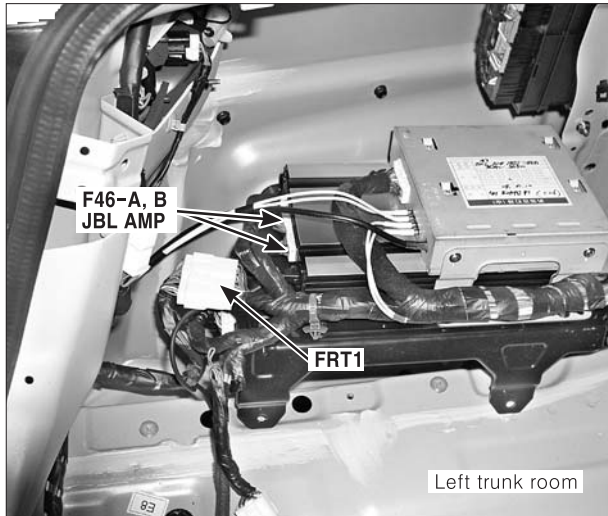

PHOTO.92

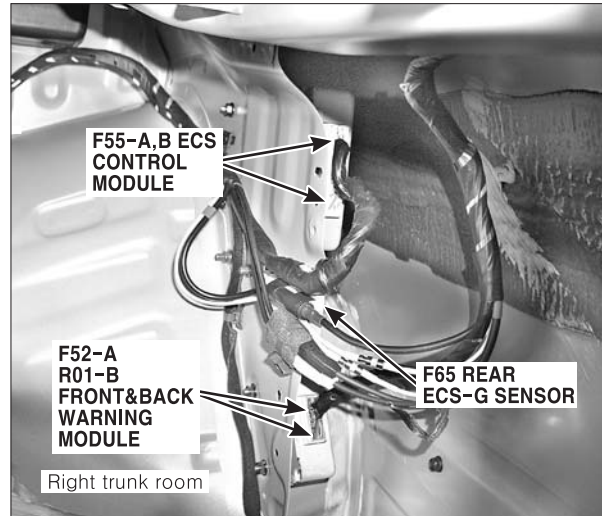

PHOTO.93



PHOTO.94

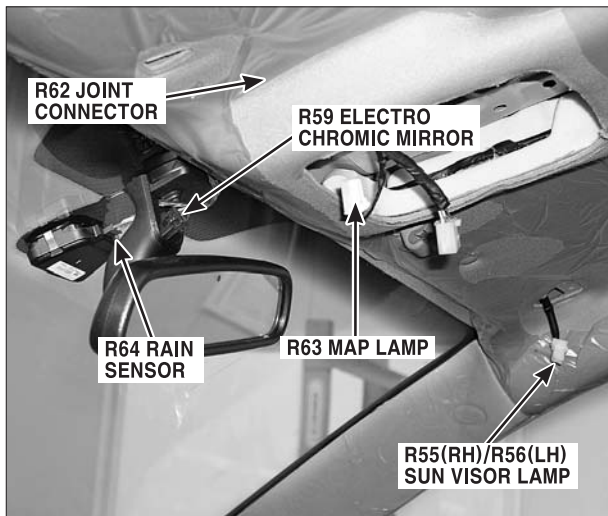

PHOTO.95

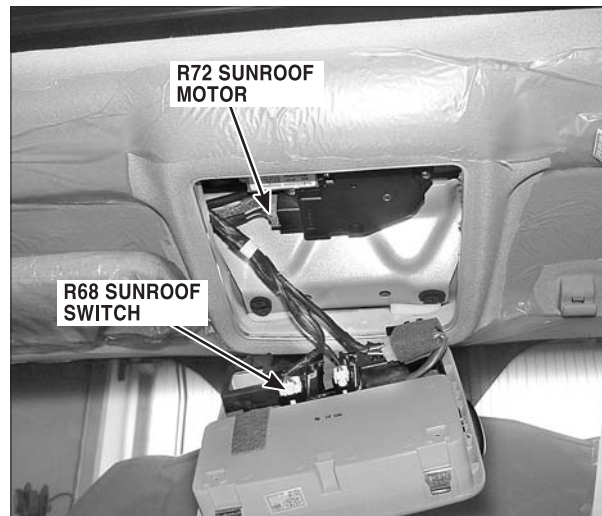

PHOTO.96



COMPONENT LOCATIONS

COMPONENT LOCATIONS (17)

CL-17

PHOTO.97

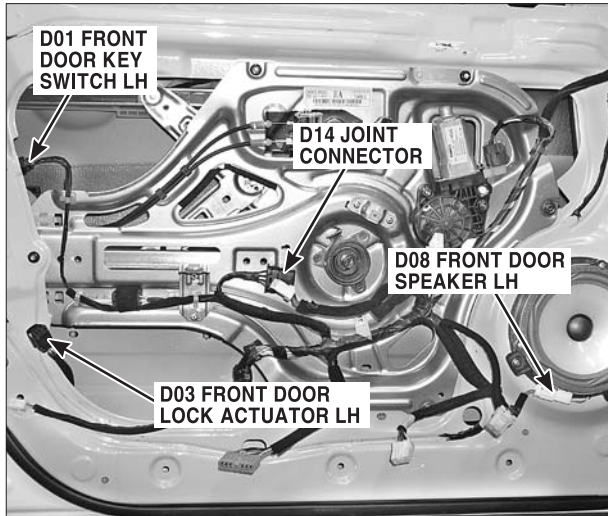

PHOTO.98

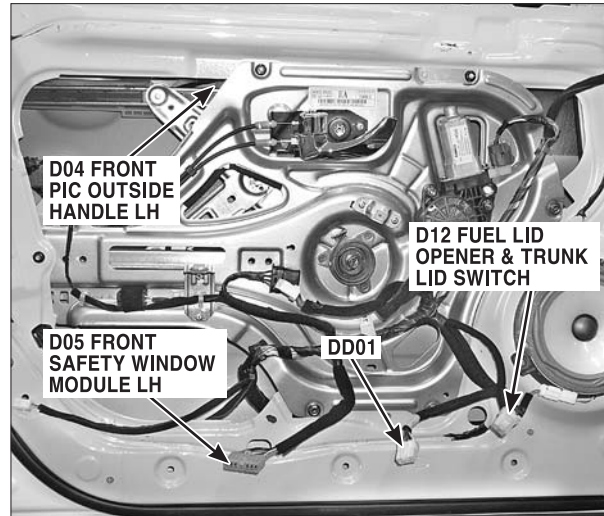

PHOTO.99

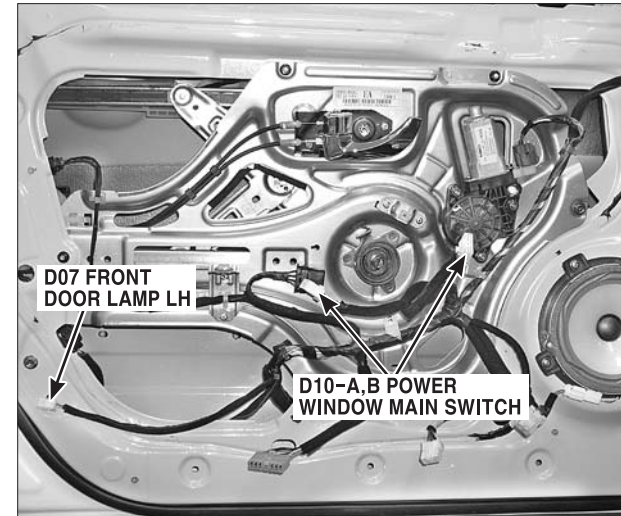

PHOTO.100

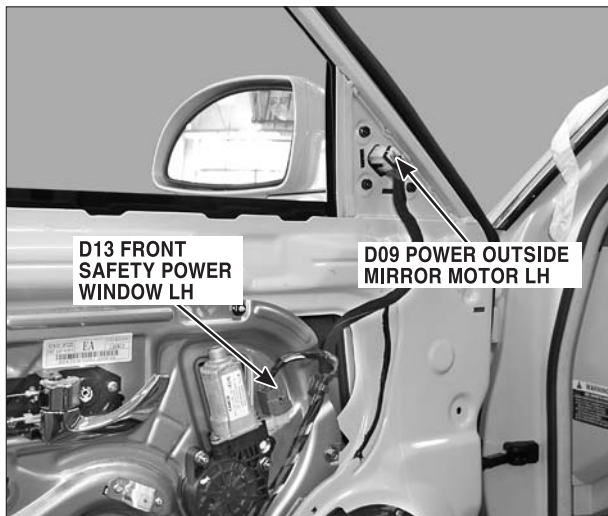

PHOTO.101

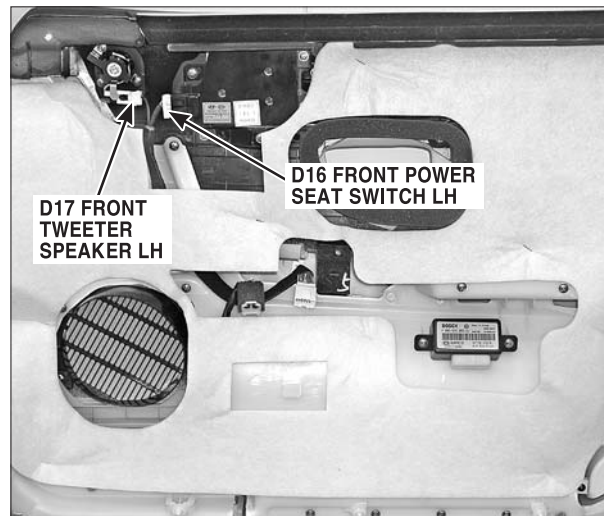
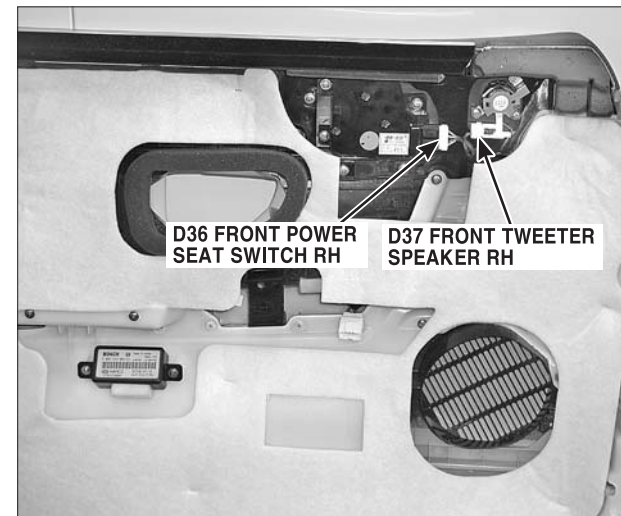

PHOTO.102



COMPONENT LOCATIONS

COMPONENT LOCATIONS (18)

CL-18

PHOTO.103

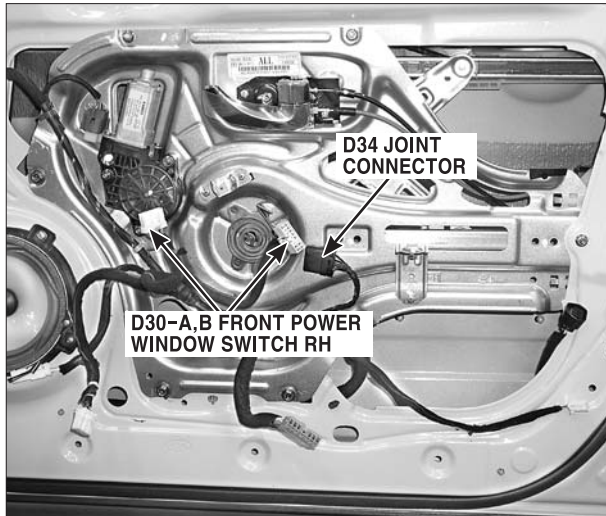

PHOTO.104

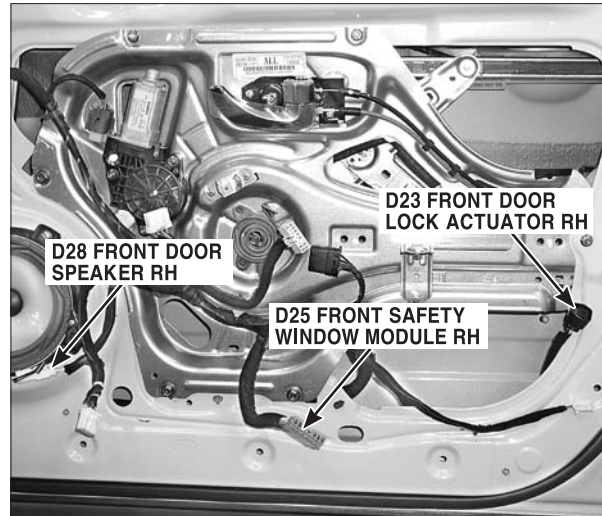

PHOTO.105

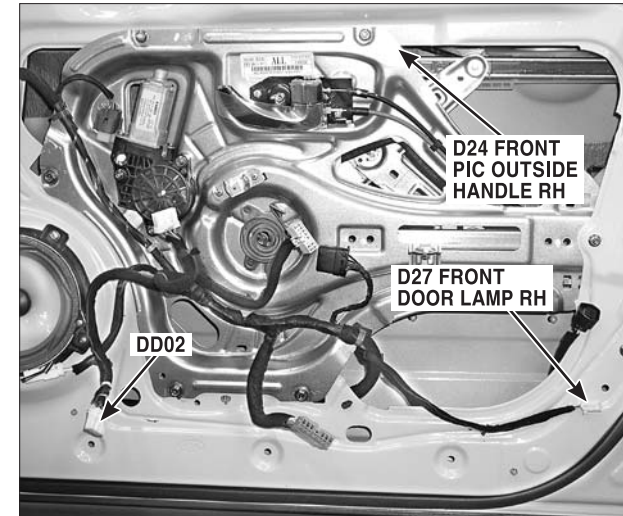

PHOTO.106

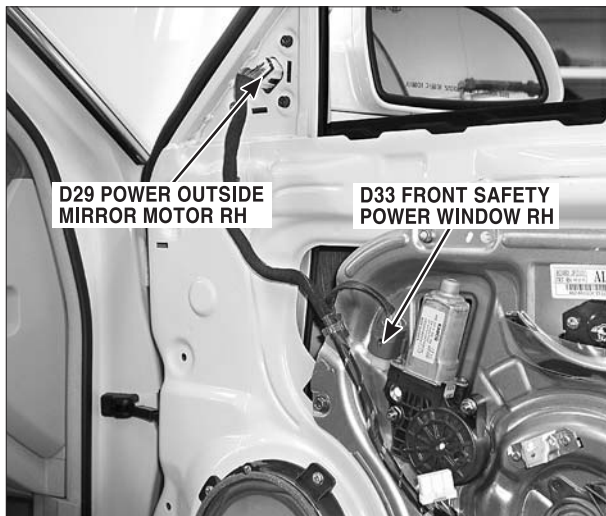

PHOTO.107

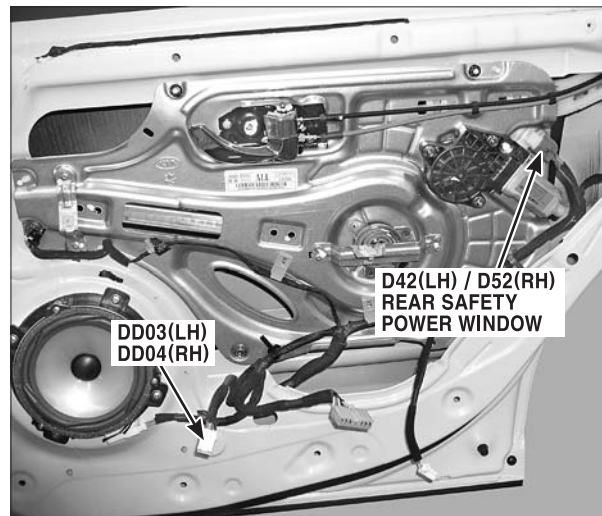
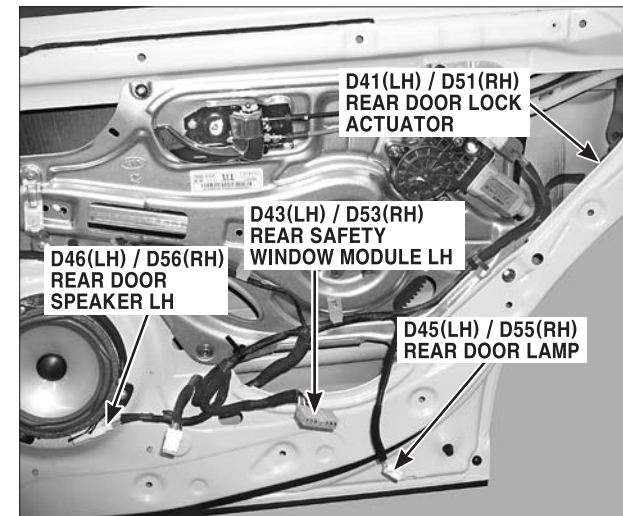

PHOTO.108



COMPONENT LOCATIONS

COMPONENT LOCATIONS (19)

CL-19

PHOTO.109

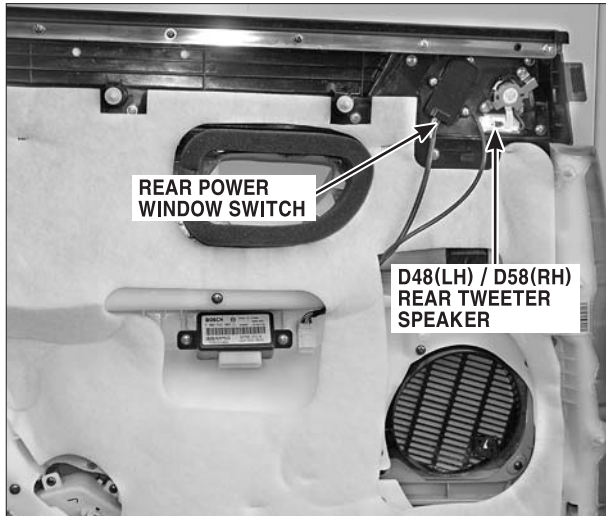

PHOTO.110



PHOTO.111

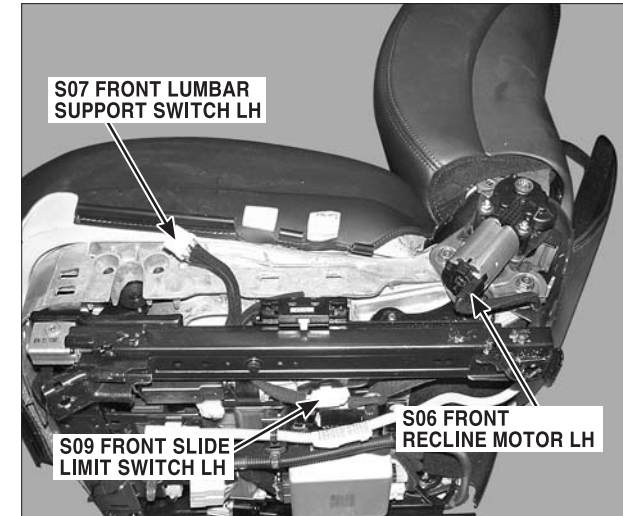

PHOTO.112

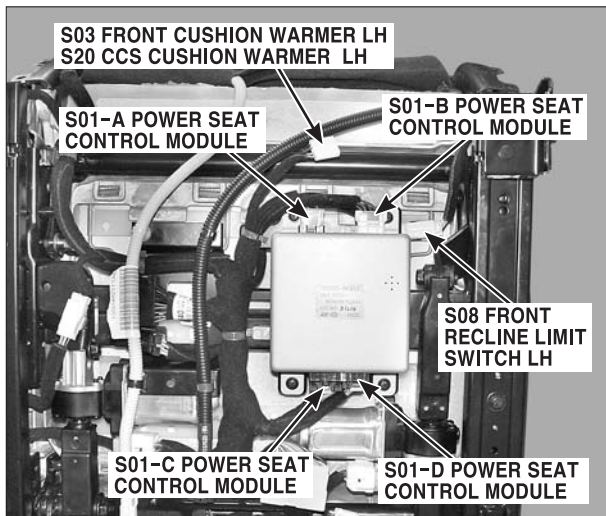

PHOTO.113

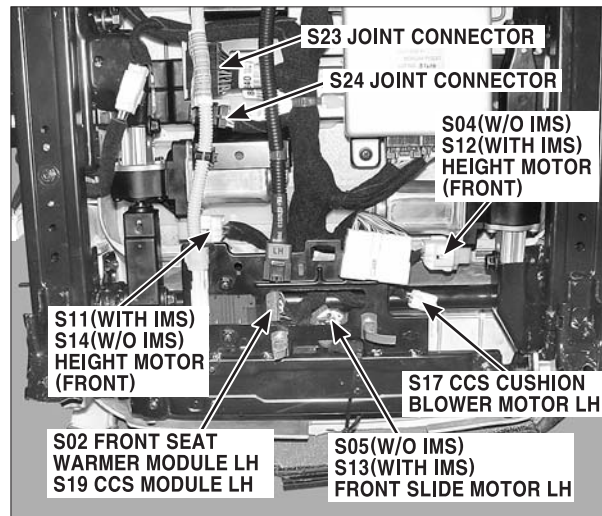
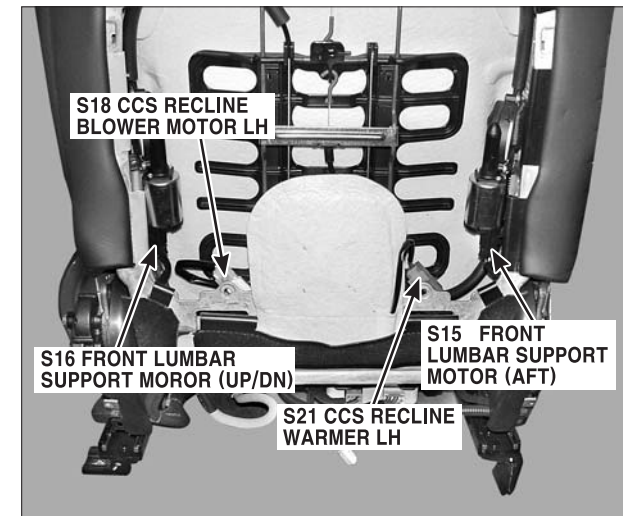

PHOTO.114



COMPONENT LOCATIONS

COMPONENT LOCATIONS (20)

CL-20

PHOTO.115

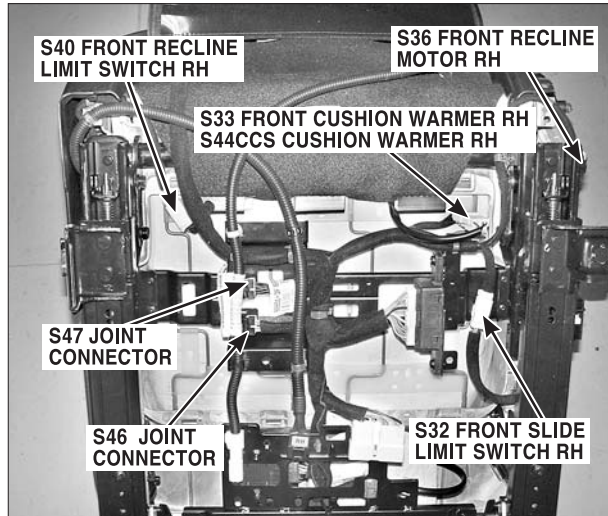

PHOTO.116

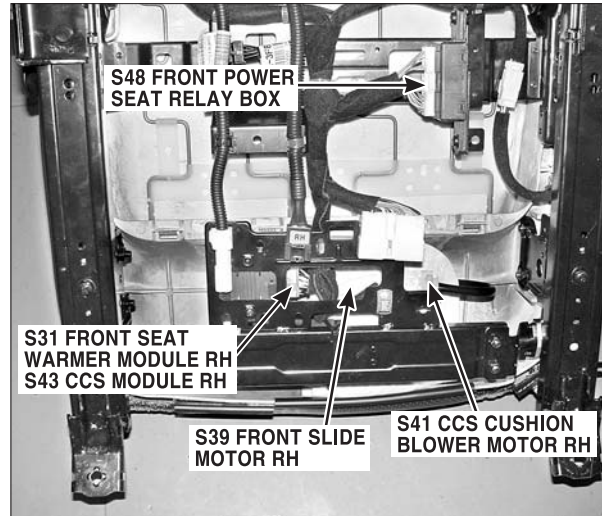

PHOTO.117

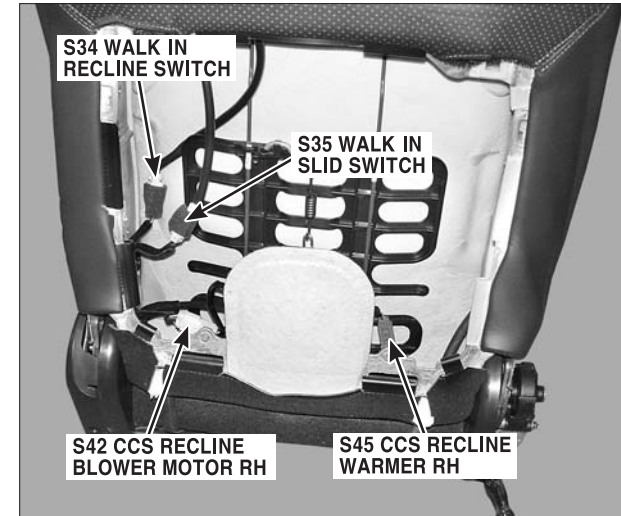

PHOTO.118

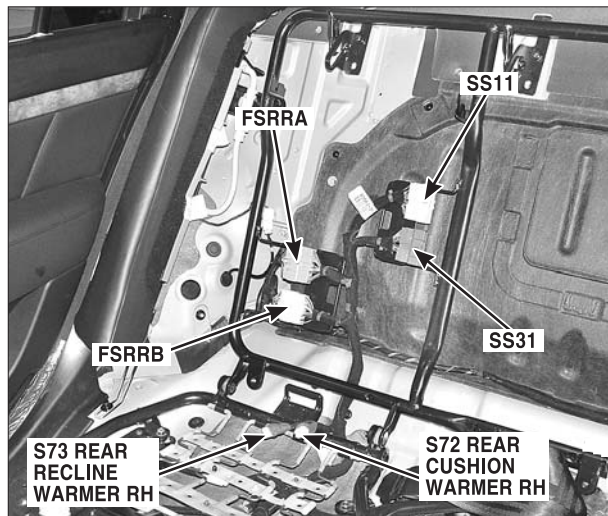

PHOTO.119

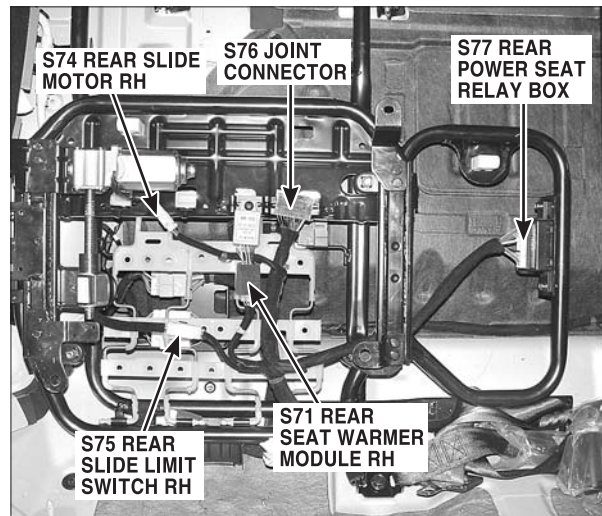
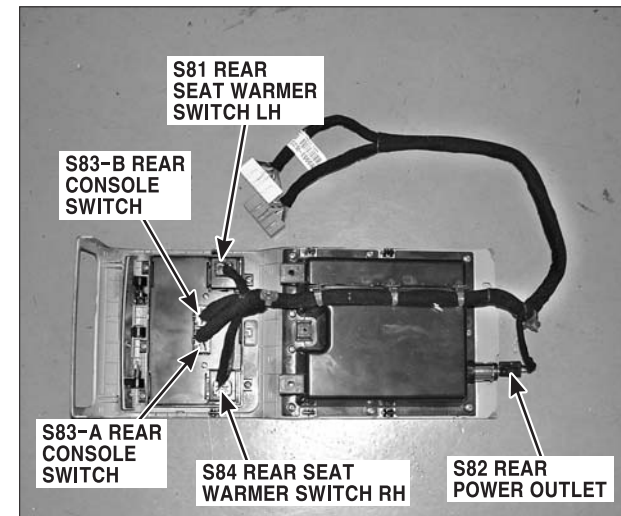

PHOTO.120



COMPONENT LOCATIONS

COMPONENT LOCATIONS (21)

CL-21

PHOTO.121

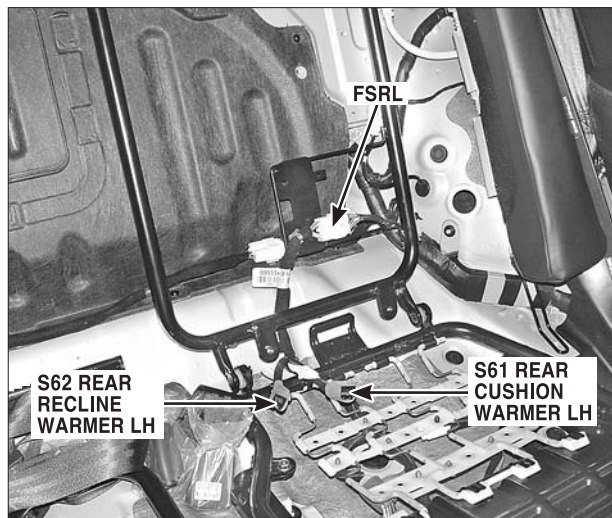
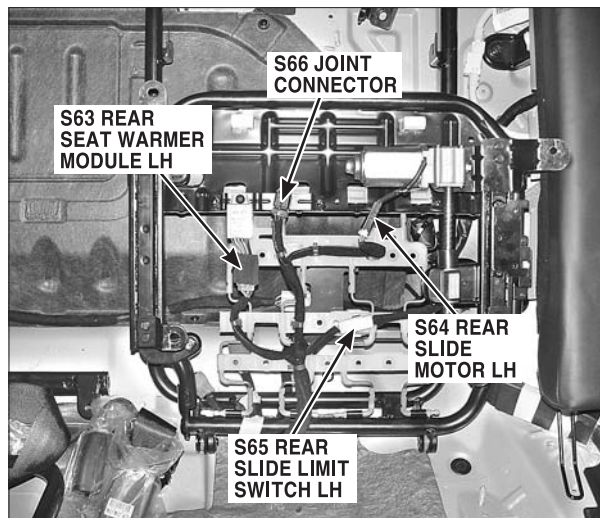

PHOTO.122



HARNESS CONNECTORS

EADDAB9E

HARNESS CONNECTORS (1)

CC-1

CC101

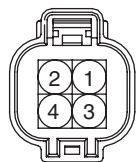

KUM_KNMWP_04F_Gr

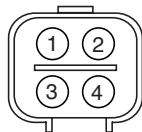

KUM_PB621_04120

CC102

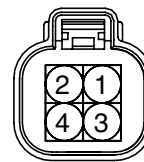

KUM_NMWP_04F_B

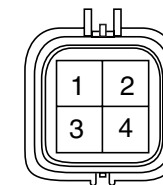

KUM_PB625_04020

CC103

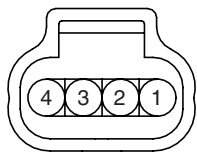

PKD_GT150_04F_Gr

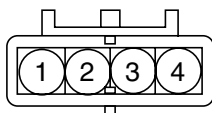

CR04M004

CF12

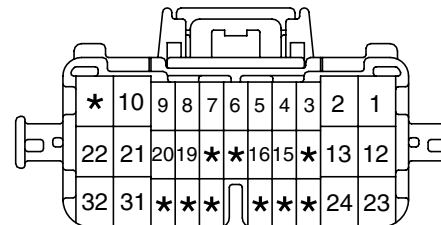

KET_0409_32F_W

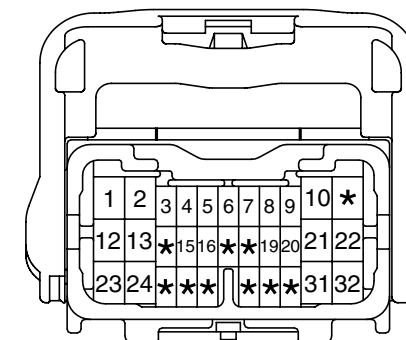

KET_0409_32M_B

DD01

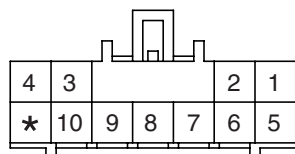

KUM_CDR_11F_W

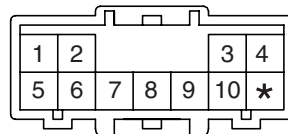

KUM_CDR_11M_B

DD02

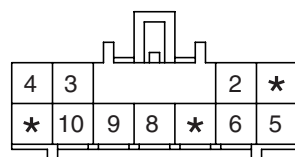

KUM_CDR_11F_W

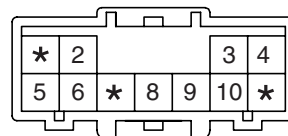

KUM_CDR_11M_B

DD03/DD04

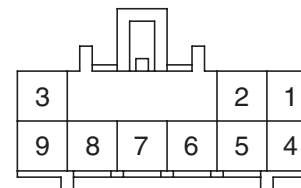

KUM_CDR_09F_W

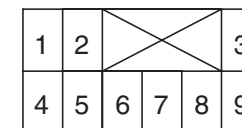

KUM_PH841_09010

EC11

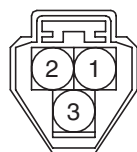

KUM_NMWP_03F_B

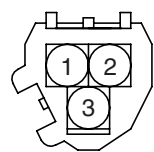

KUM_NMWP_03M_B

EE12

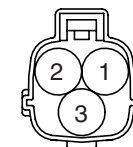

KET_312IWP_03F_B

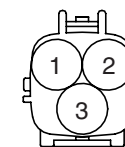

KET_312IWP_03M_B

HARNES CONNECTORS

HARNES CONNECTORS (2)

CC-2

EF12

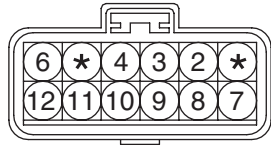

KUM_NMWP_12F_B

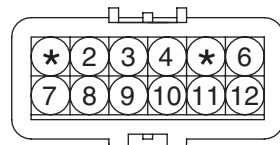

KUM_NMWP_12M_B

EFW11

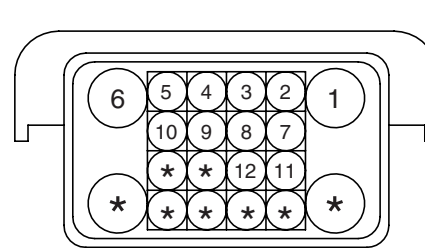

AMP_MTIJPT_20F_B

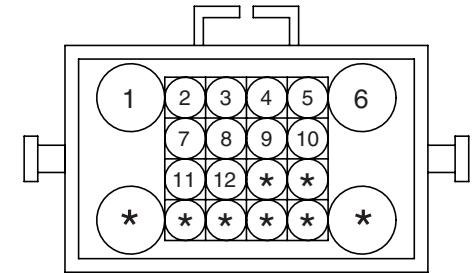

AMP_MTIJPT_20M_B

FDDA

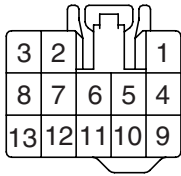

KET_090III_13F_Gr

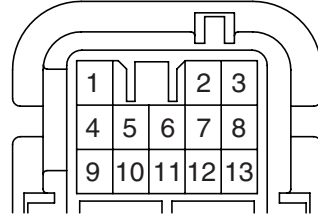

Fddb

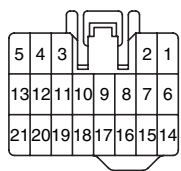

KET_050_21F_B

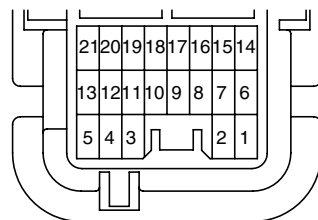

KET_DOOR_34M_W

FDPA

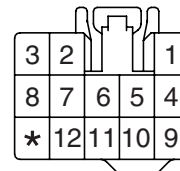

KET_090III_13F_Gr

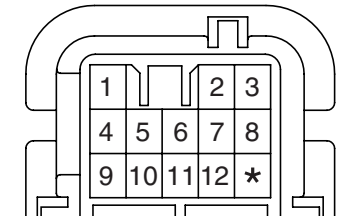

FDRL

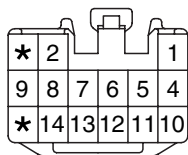

KET_090II_15F_W

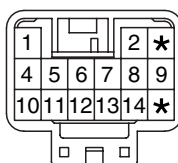

KET_090II_15M_W

FDPB

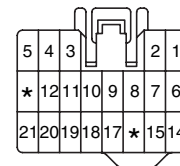

KET_050_21F_B

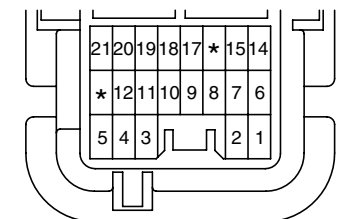

KET_DOOR_34M_W

FDRR

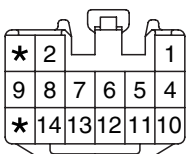

KET_090II_15F_W

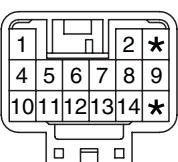

KET_090II_15M_W

FF01

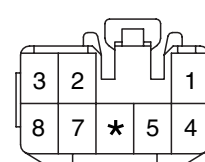

KET_090II_08F

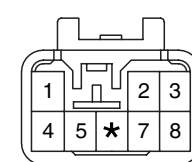

KET_090II_08M_W

HARNES CONNECTORS

HARNES CONNECTORS (3)

CC-3

FF11

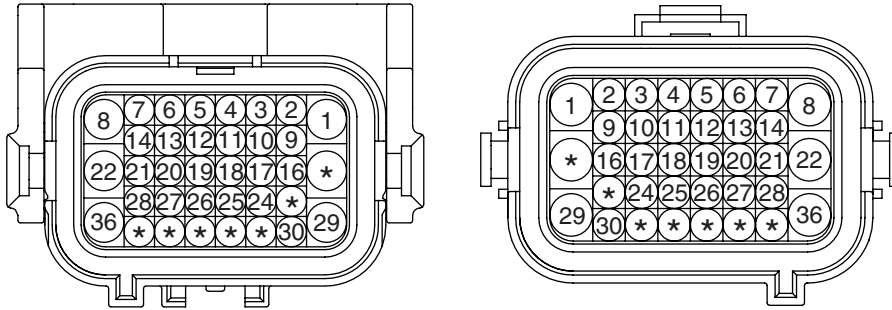

AMP_MTIJPT_36F_B

AMP_MTIJPT_36M_B

FF31

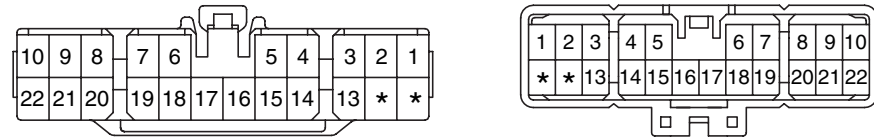

KET_090II_22F_W

KET_090II_22M_W

FRR1

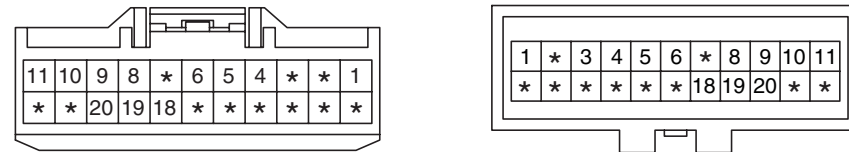

AMP_090III_22F_W

AMP_090III_22M_W

FRT1

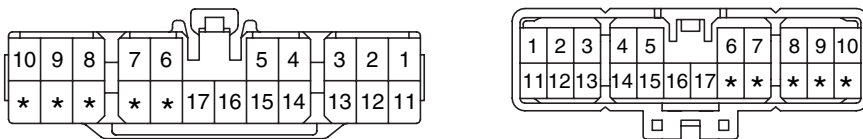

KET_090II_22F_W

KET_090II_20M_W

FSFD

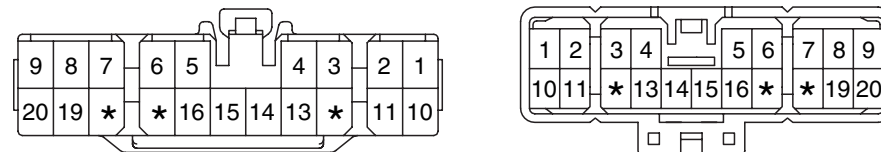

KET_090II_20F_W

KET090II_20M

FSFP

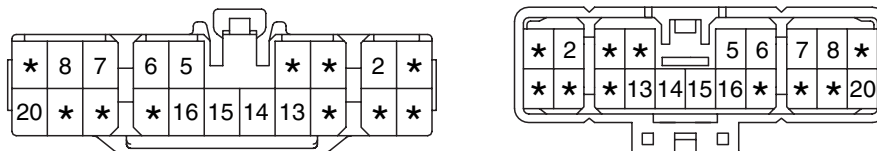

KET_090II_20F_W

KET090II_20M

FSNA

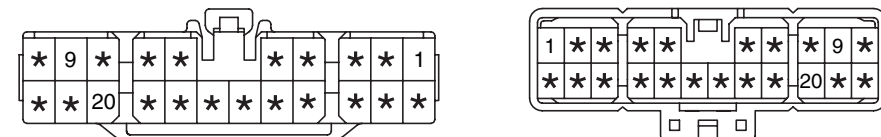

KET_090II_22F_W

KET090II_22M

FSNB

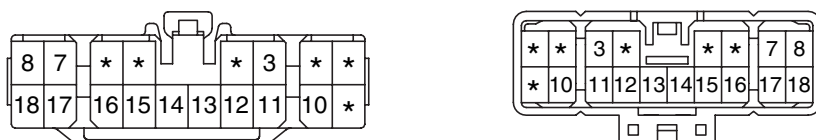

KET_090II_18F_W

KET090II_18M

FSRL



KET_090II_11F_W

KET090II_11M

HARNES CONNECTORS

HARNES CONNECTORS (4)

CC-4

FSRRA

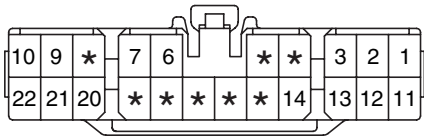

KET_090II_22F_G

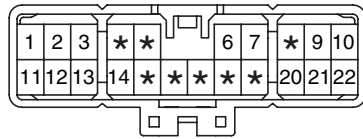

KET090II_22M

FSRRB

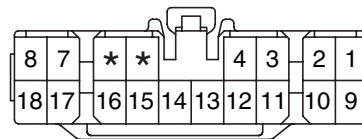

KET_090II_18F_W

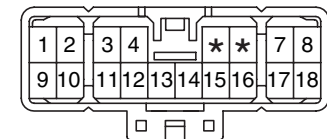

KET090II_18M

MA0A

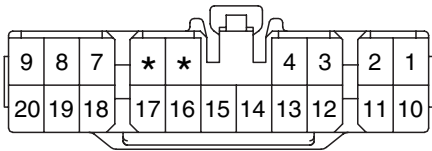

KET_090II_20F_W

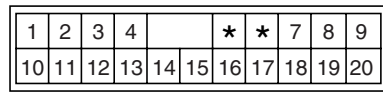

KET_MG641083

MA0B

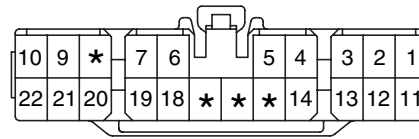

KET_090II_22F_W

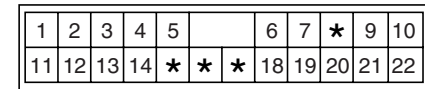

KET_MG641089

MA12

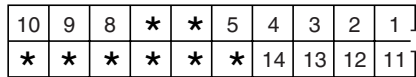

AMP_ABG_20F_B

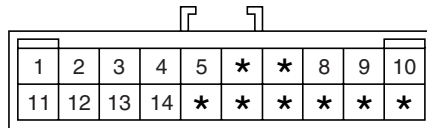

AMP_ABG_20M_B

MA32

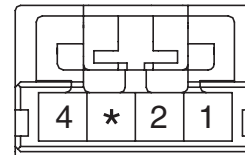

AMP_MQS_04F_Y_040

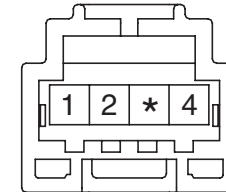

AMP_MQS_04M_Y_040

MC12

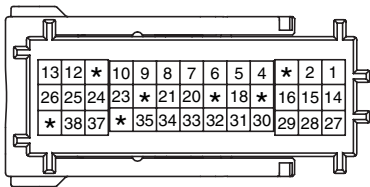

AMP_0409LIF_39F_W

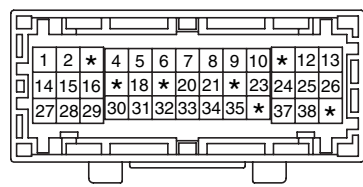

AMP_LIF0409_39M_W

MFL12

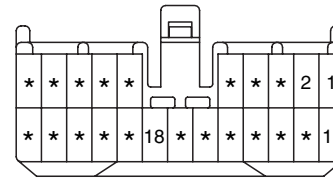

KET_050_23F_W

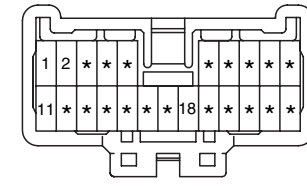

KET_050_23M_W

MFL22

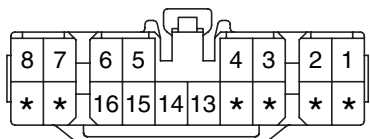

KET_090II_18F_W

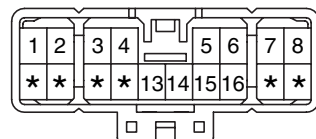

KET_090II_18M_W

MFL42

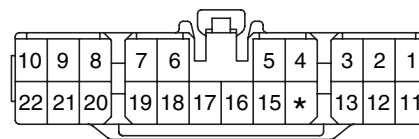

KET_090II_22F_W

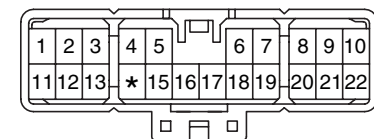

KET_090II_22M_W

HARNES CONNECTORS

HARNES CONNECTORS (5)

CC-5

MFL52

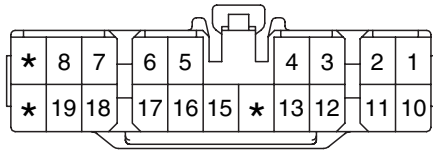

KET_090II_20F_B

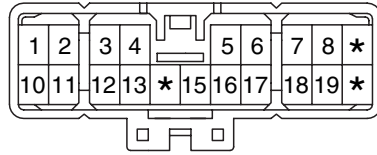

KET_090II_20M_B

MFL62

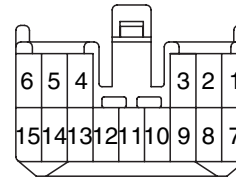

KET_050_15F_W

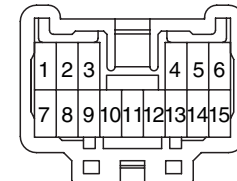

KET_050_15M_W

MFR12

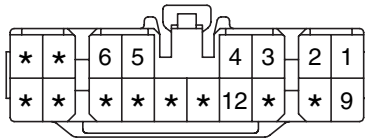

KET_090II_18F_W

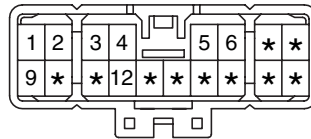

KET_090II_18M_W

MFR22

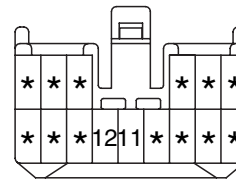

KET_050_15F_W

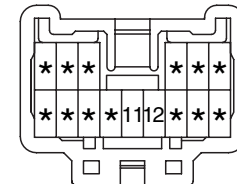

KET_050_15M_W

MFR32

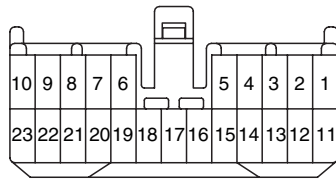

KET_050_23F_W

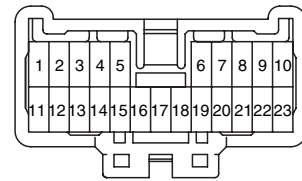

KET_050_23M_W

MFR42

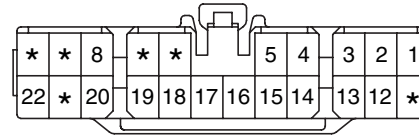

KET_090II_22F_W

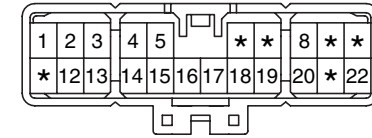

KET_090II_22M_W

MFR52

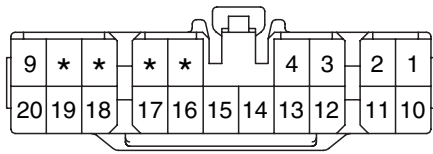

KET_090II_20F_B

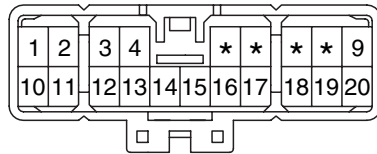

KET_090II_20M_B

MM01

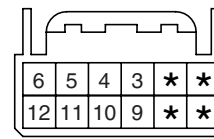

AMP_025_12F_W

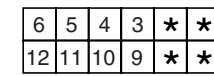

AMP_025_12F_W

MM12

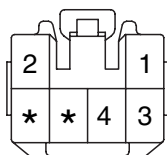

KET_090II_06F_W

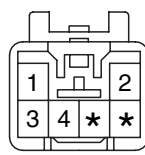

KET_090II_06M_W

RR01

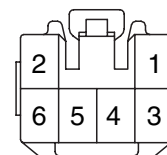

KET_090II_06F_B

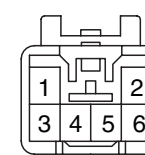

KET_090II_06M_B

HARNES CONNECTORS

HARNES CONNECTORS (6)

CC-6

RR02

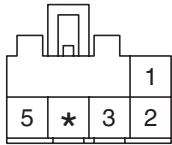

KUM_CDR_05F_W

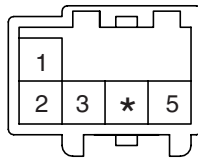

KUM_CDR_05M

RR11

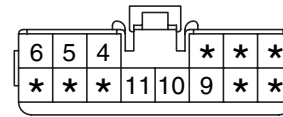

KET_090II_14F_W

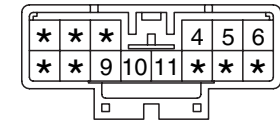

KET_090II_14M_W

RRW11

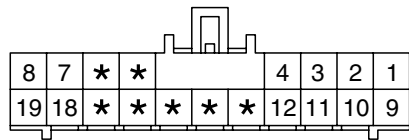

KUM_CDR_19F_W

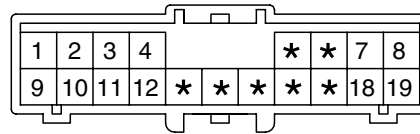

KUM_CDR_19M_W

RRW21

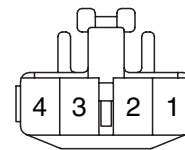

KET_090II_04F_W

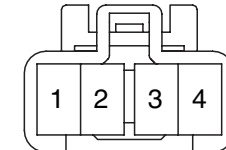

KET_090II_04M_W

SS01

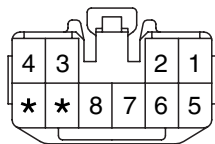

KET_090II_10F

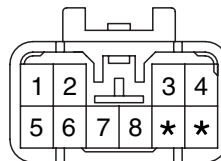

KET_090II_10M

SS11

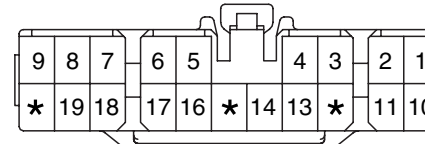

KET090II_20F_L

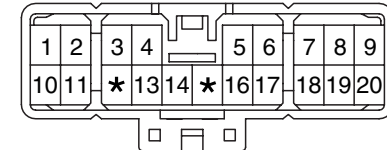

KET090II_20M_L

SS31

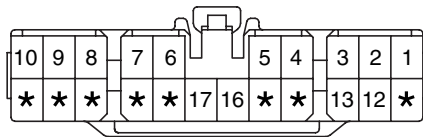

KET090II_22F_Y

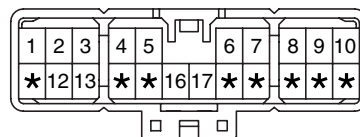

KET090II_22M_Y

BLANK

E/R JUNCTION BOX (1)

CC-7

JC01

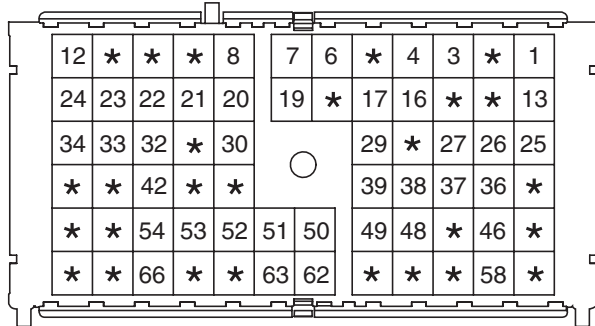

PKD_280_68F_GR_BECCGR

JE0B

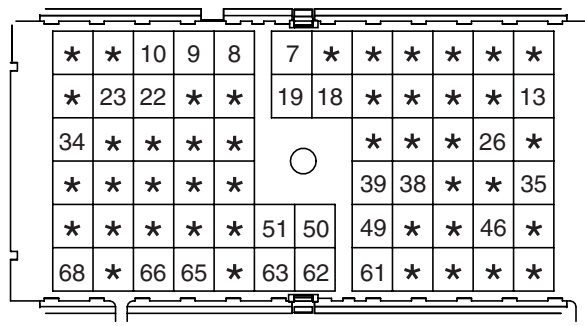

PKD_280_68F_B_BECCB

JE0F

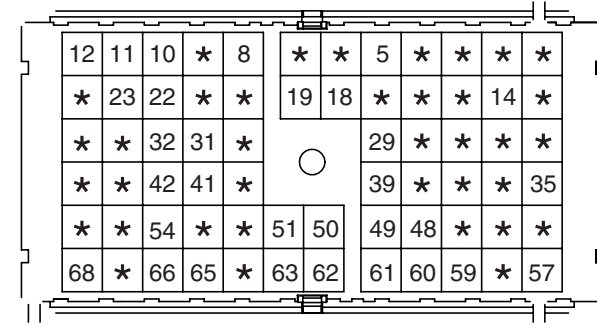

PKD_280_68F_BR_BECCBR

JE0A

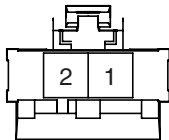

PKD_800_02F_W_BECC

BLANK

BLANK

I/P JUNCTION BOX (1)

CC-8

I/P-A

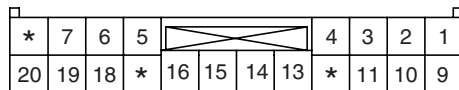

AMP_0925_20F_W

I/P-B

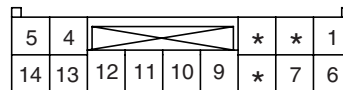

AMP_0925_14F_W

I/P-C

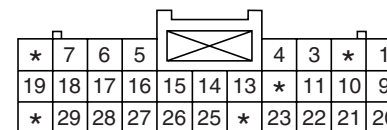

AMP_090III_30F_W

I/P-D

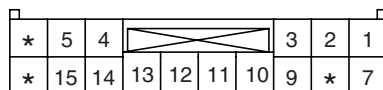

AMP_0925_16F_W

I/P-E

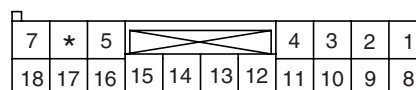

AMP_0925_18F_W

I/P-F

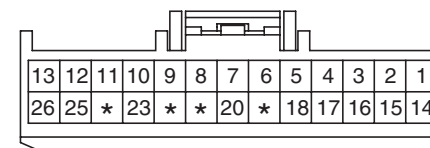

AMP_090III_26F_W

I/P-G

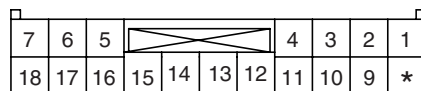

AMP_0925_18F_W

I/P-H

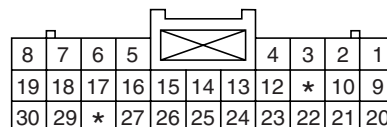

AMP_090III_30F_W

I/P-J

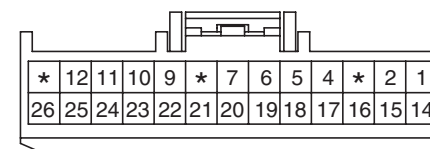

AMP_090III_26F_W

I/P-K

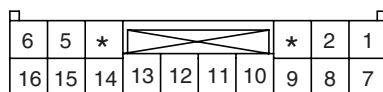

AMP_0925_16F_W

I/P-L

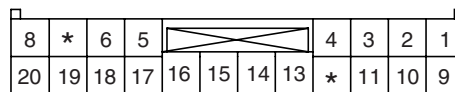

AMP_0925_20F_W

BLANK

JOINT CONNECTORS (1)

CC-9

D14

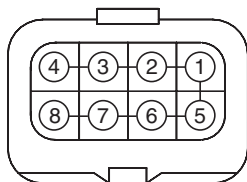

KET_090IWP_08F_B_JCH

D34

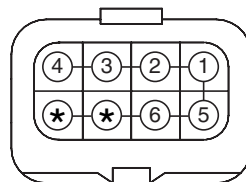

KET_090IWP_08F_B_JCH

E26

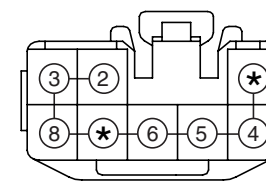

KET_090II_08F_B

F15

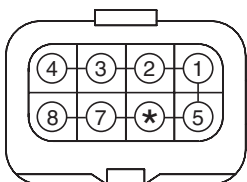

KET_090IWP_08F_B_JCH

F47

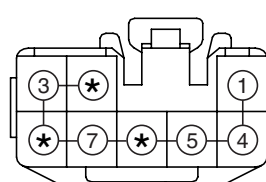

KET_090II_08F_W

F62

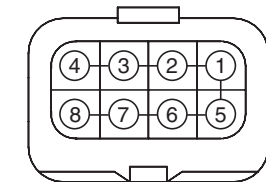

KET_090IWP_08F_B_JCH

M30

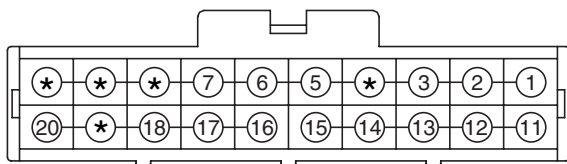

KET_090II_20F_B_JCH

M31

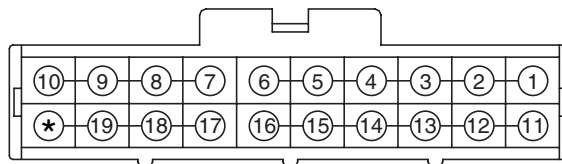

KET_090II_20F_B_JCH

M32

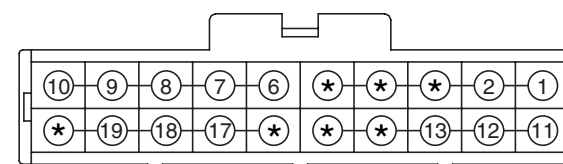

KET_090II_20F_B_JCH

M33

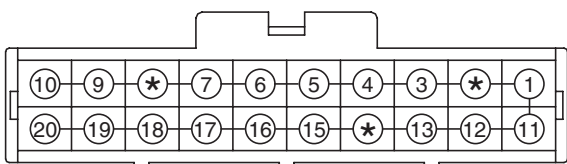

KET_090II_20F_B_JCH

M34

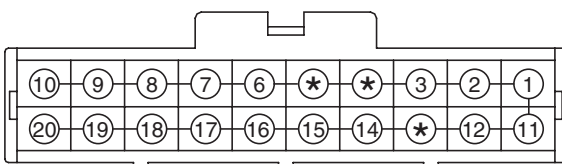

KET_090II_20F_B_JCH

M35

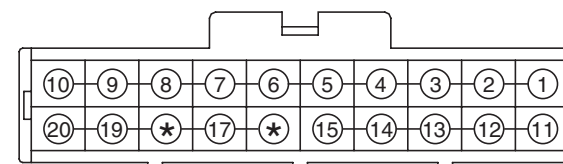

KET_090II_20F_B_JCH

R62

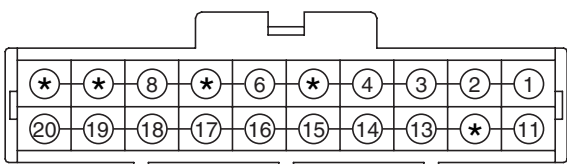

KET_090II_20F_B_JCH

S23

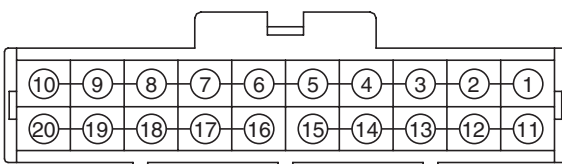

KET090II_20F_JCH

S24

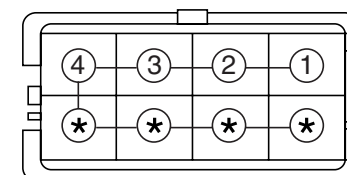

KET070_08F_B_JCH

JOINT CONNECTORS

JOINT CONNECTORS (2)

CC-10

S46

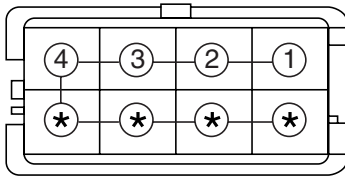

KET070_08F_B_JCH

S47

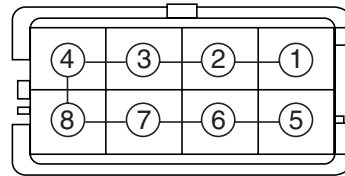

KET070_08F_JCH

S66

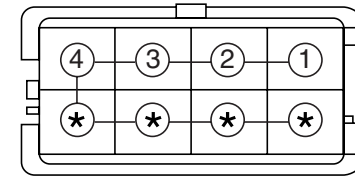

KET070_08F_JCH

S76

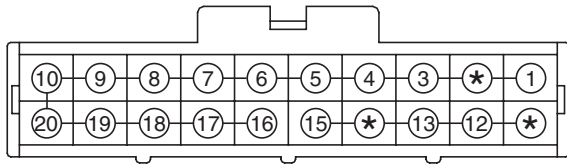

KET090II_20F_JCH

S106

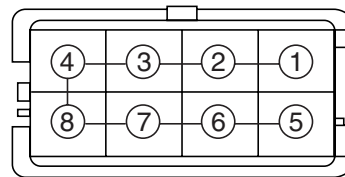

KET070_08F_JCH

BLANK

MAIN HARNESS (1)

HL-1

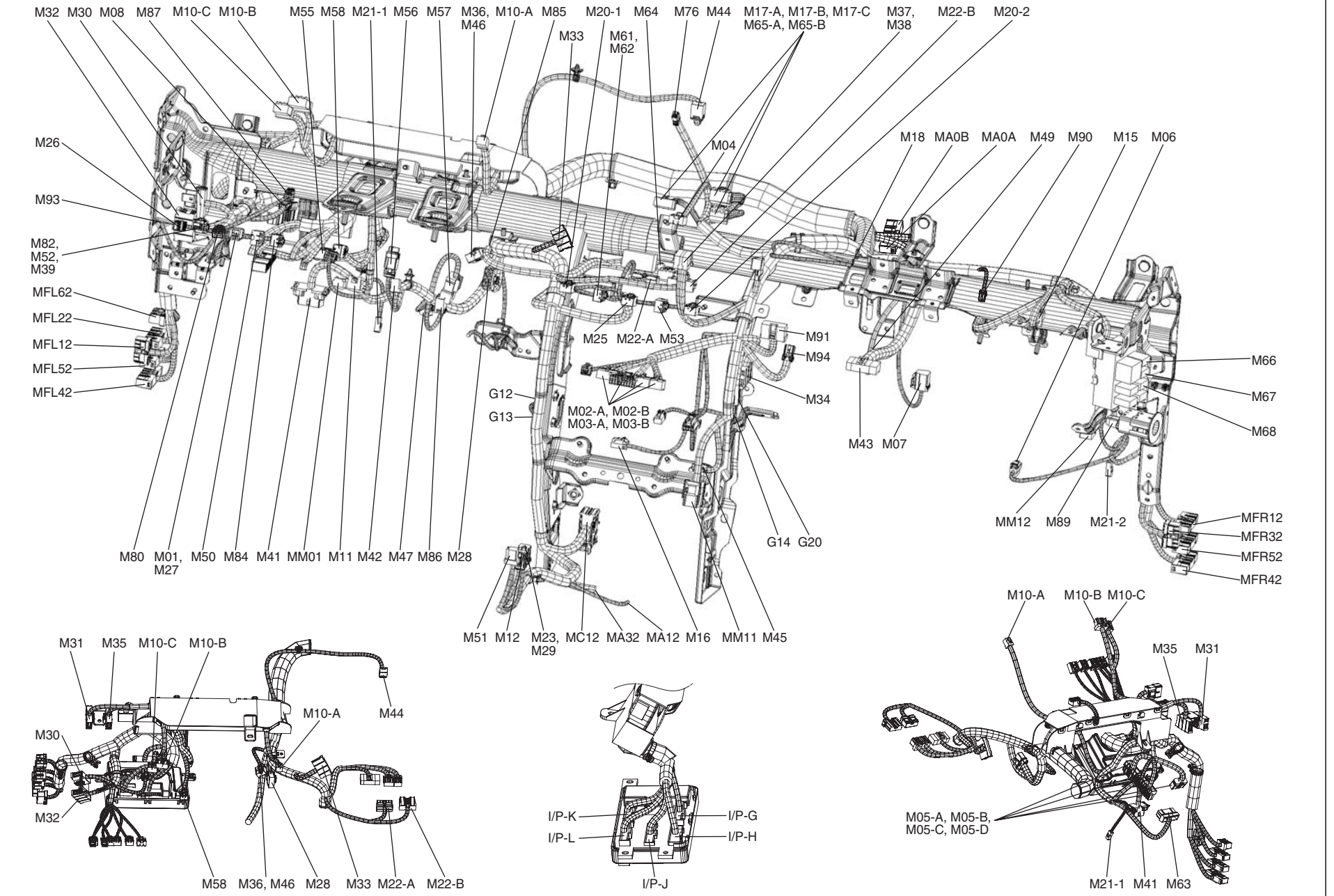

MAIN HARNESS

MAIN HARNESS (2)

HL-2

MAIN HARNESS

M01	Air Purifier Switch	M50	Rheostat
M02-A	Audio	M51	Rear Curtain Switch
M02-B	Audio	M52	Rear Fog Lamp Switch
M04	Analog Clock	M53	Rear Vent Switch
M05-A	BCM(Body Control Module)	M55	Steering Tilt & Telescopic Switch
M05-B	BCM(Body Control Module)	M56	Steering Angle Sensor
M05-C	BCM(Body Control Module)	M57	Telescopic Motor & Sensor
M05-D	BCM(Body Control Module)	M58	Tilt Motor & Sensor
M06	Blower Motor	M61	TCS Switch
M07	FET(Field Effect Transistor)	M63	Tilt & Telescopic Module
M10-A	Instrument Cluster	M65-A	Trip Computer
M10-B	Instrument Cluster	M65-B	Trip Computer
M10-C	Instrument Cluster	M66	HTD Glass Relay
M11	Driver Air Bag	M67	FOG LP (RR) Relay
M12	ECS Switch	M68	ADJ Pedal Relay
M16	Front Cigarette Lighter	M80	Adjustable Pedal Switch
M18	Passenger Air Bag	M81	ATM Shift Lever ILL.
M20-1	Front Seat Warmer Switch LH	M84	Front & Back Warning Switch
M20-2	Front Seat Warmer Switch RH	M85	Immobilizer Control Module (W/O PIC)
M21-1	Front Foot Lamp LH	M86	Key Solenoid
M21-2	Front Foot Lamp RH	M87	Trip Mode Reset Switch
M25	Hazard Switch	M89	PAB On/Off Switch
M26	Head Lamp Leveling Switch (Manual)	M90	RF Receiver
M27	Head Lamp Washer Switch	M91	Rear Curtain Module
M28	Ignition Switch	MA0A	Connection With AIR CON Harness
M30	Joint Connector	MA0B	Connection With AIR CON Harness
M31	Joint Connector	MA12	Connection With AIR BAG Harness
M32	Joint Connector	MA32	Connection With AIR BAG Harness
M33	Joint Connector	MC12	Connection With CONTROL Harness
M34	Joint Connector	MFL12	Connection With FLOOR LH Harness
M35	Joint Connector	MFL22	Connection With FLOOR LH Harness
M36	Ignition Key ILL. & Door Warning Switch (W/O PIC)	MFL42	Connection With FLOOR LH Harness
M37	Audio Key Console	MFL52	Connection With FLOOR LH Harness
M41	Data Link Connector	MFL62	Connection With FLOOR LH Harness
M42	Multifunction Switch	MFR12	Connection With FLOOR RH Harness
M44	Auto Light & Photo Sensor	MFR22	Connection With FLOOR RH Harness
M45	PIC Interior Antenna #1	MFR32	Connection With FLOOR RH Harness
M46	PIC Door Warning Switch (With PIC)	MFR42	Connection With FLOOR RH Harness
M47	PIC Key Set Switch	MFR52	Connection With FLOOR RH Harness
M49	RF Antenna	MM01	Connection With STEERING Harness
		MM12	Connection With GLOVE BOX Harness

I/P-G	Connection With I/P JUNCTION BOX Harness
I/P-H	Connection With I/P JUNCTION BOX Harness
I/P-J	Connection With I/P JUNCTION BOX Harness
I/P-K	Connection With I/P JUNCTION BOX Harness
I/P-L	Connection With I/P JUNCTION BOX Harness
G12	Ground
G13	Ground
G14	Ground
G20	Ground

GLOVE BOX HARNESS

M72	Glove Box ILL.
M73-1	Glove Box Lamp Switch
M73-2	Glove Box Lamp Switch
M75	Trunk Lid Main Switch
MM12	Connection With MAIN Harness

STEERING HARNESS

M77	Horn Switch
M78	Steering Remocon LH
M79	Steering Remocon RH
MM01	Connection With MAIN Harness

GLOVE BOX HARNESS

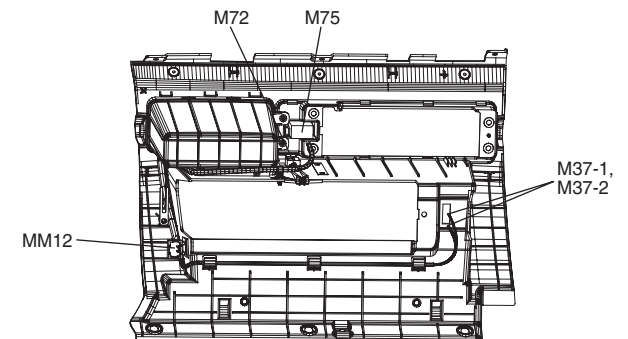

ENGINE HARNESS/ BATTERY HARNESS (1)

HL-3

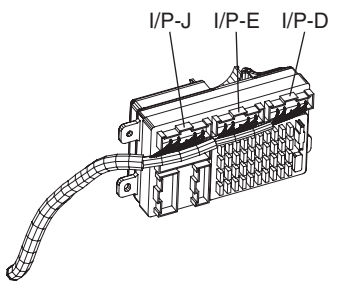
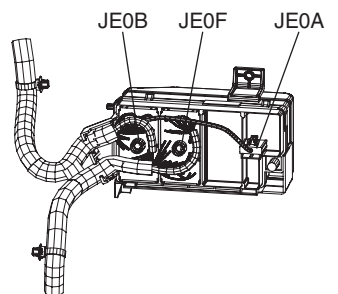
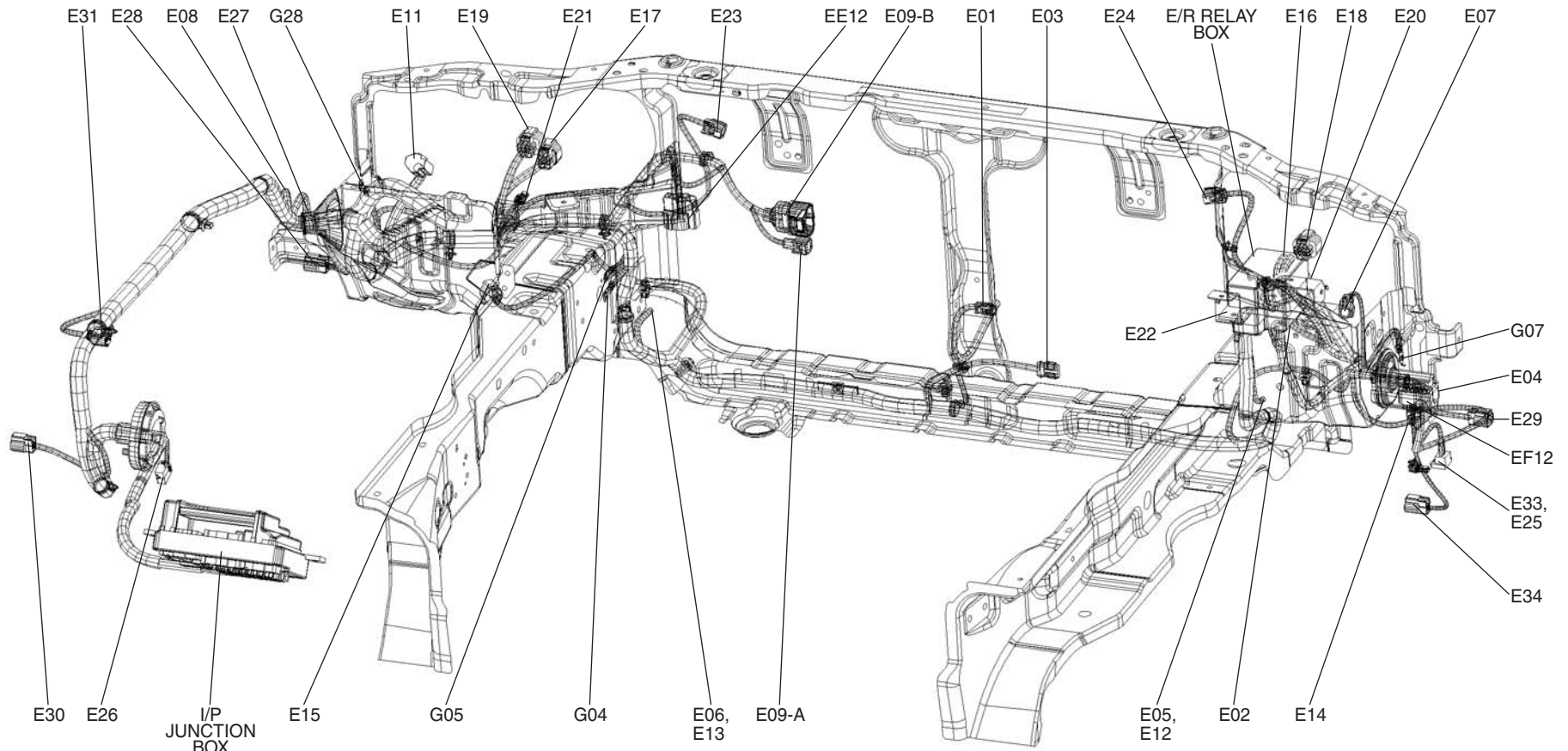

BATTERY HARNESS

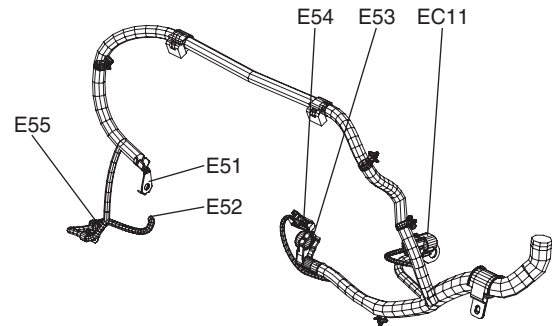

ENGINE HARNESS/ BATTERY HARNESS

ENGINE HARNESS/ BATTERY HARNESS (2)

HL-4

ENGINE HARNESS

E01 Ambient Sensor
E02 A/C Pressure Transducer
E03 AQS Sensor
E04 External Buzzer
E07 Burglar Alarm Horn
E08 Front Wheel Sensor LH
E09-A Cooling Fan Controller
E09-B Cooling Fan Controller
E11 Cooling Fan Relay
E12 Front Impact Sensor RH
E13 Front Impact Sensor LH
E14 Front Turn Signal Lamp RH
E15 Front Turn Signal Lamp LH
E16 Head Lamp RH (W/O HID)
E17 Head Lamp LH (W/O HID)
E18 Head Lamp RH (With HID)
E19 Head Lamp LH (With HID)
E20 Head Lamp Leveling Actuator RH
E21 Head Lamp Leveling Actuator LH
E22 Hood Switch
E23 Horn LH
E24 Horn RH
E25 Head Lamp Washer Motor
E26 Joint Connector
E27 Front ECS Actuator LH
E30 Side Repeater Lamp LH
E33 Washer Motor
E34 Washer Level Sensor
E35 Head Lamp Washer Relay
E37 DRL Relay
E39 H/LP (LO-RH) Relay
E40 ECS Relay

EE12 Connection With BATTERY Harness
EF12 Connection With FLOOR RH Harness
JE0A Connection With E/R JUNCTION BOX Harness
JE0B Connection With E/R JUNCTION BOX Harness
JE0F Connection With E/R JUNCTION BOX Harness
I/P-D Connection With I/P JUNCTION BOX Harness
I/P-E Connection With I/P JUNCTION BOX Harness
I/P-F Connection With I/P JUNCTION BOX Harness
G04 Ground
G05 Ground
G06 Ground
G07 Ground
G28 Ground

BATTERY HARNESS

E51 Generator
E52 Generator
E53 Start Motor
E54 Start Solenoid
E55 A/C Compressor
EC11 Connection With CONTROL Harness
EE12 Connection With ENGINE Harness

FLOOR HARNESS (1)

HL-5

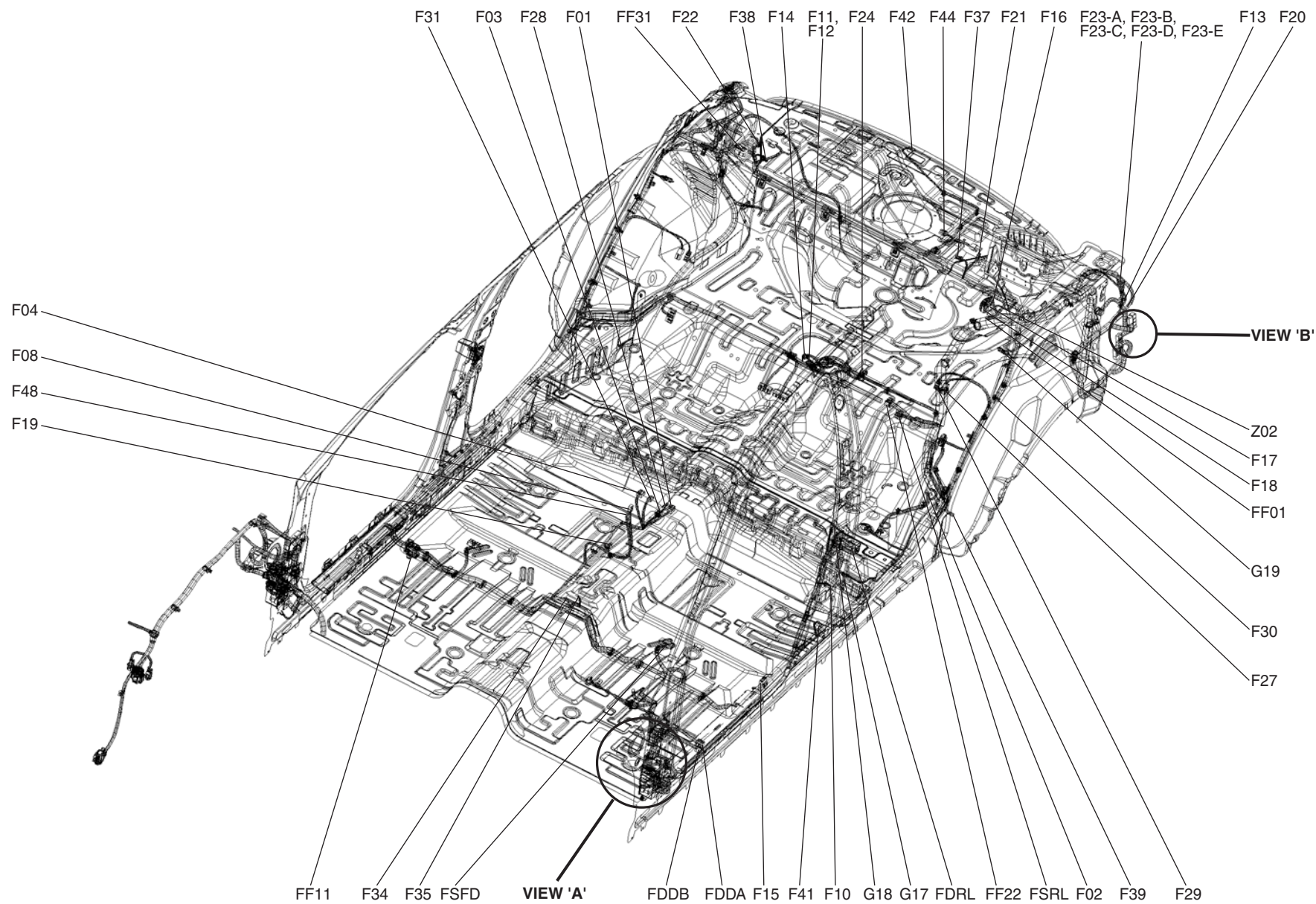

FLOOR HARNESS

FLOOR HARNESS (2)

HL-6

VIEW 'A'

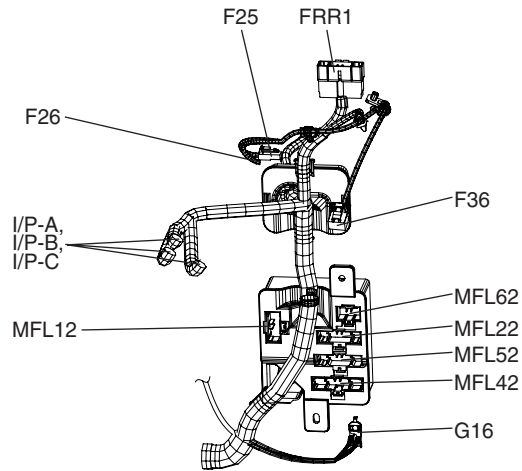

FLOOR LH HARNESS

F02	Head Lamp Leveling Sensor (Auto)	FDDA	Connection With FRONT DOOR LH Harness
F04	Car Phone	FDDB	Connection With FRONT DOOR LH Harness
F08	Console Power Outlet	FDRL	Connection With REAR DOOR LH Harness
F10	Front Door Switch LH	FF01	Connection With FLOOR EXT. Harness
F11	Fuel Sender & Fuel Pump Motor	FF11	Connection With FLOOR RH Harness
F13	Fuel Lid Actuator	FF31	Connection With FLOOR RH Harness
F15	Joint Connector	FRR1	Connection With ROOF Harness
F19	PIC Interior Antenna #2	FRT1	Connection With TRUNK Harness
F20	PIC Interface Module	FSFD	Connection With FRONT SEAT LH Harness
F21	PIC Package Tray Antenna LH	FSRL	Connection With REAR SEAT LH Harness
F22	PIC Package Tray Antenna RH	MFL12	Connection With MAIN Harness
F23-A	PIC Module	MFL22	Connection With MAIN Harness
F23-B	PIC Module	MFL42	Connection With MAIN Harness
F23-C	PIC Module	MFL52	Connection With MAIN Harness
F23-D	PIC Module	MFL62	Connection With MAIN Harness
F23-E	PIC Module	I/P-A	Connection With I/P JUNCTION BOX Harness
F25	Parking Brake Switch	I/P-B	Connection With I/P JUNCTION BOX Harness
F27	Rear Wheel Sensor LH	I/P-C	Connection With I/P JUNCTION BOX Harness
F28	Rear Cigarette Lighter	G16	Ground
F29	Rear ECS Actuator	G17	Ground
F30	Rear Door Switch LH	G18	Ground
F31	Rear Vent Temperature Switch	G19	Ground
F34	Sensor Cluster		
F35	Sports Mode Switch		
F36	Stop Lamp Switch		
F42	Trunk Room Lamp		
F44	Wooper Speaker		
F46-A	JBL Amp		
F46-B	JBL Amp		
F47	Joint Connector		
F48	Tray ILL.		

FLOOR EXT. HARNESS

F81	Humidity Sensor
F82	Rear Curtain Motor
F83	High-Mounted Stop Lamp
FF01	Connection With FLOOR LH Harness

VIEW 'B'

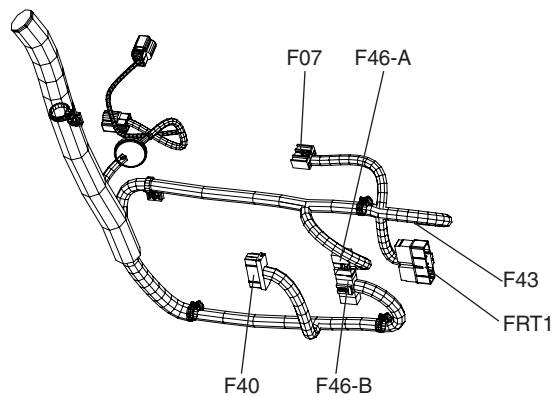

FLOOR HARNESS

FLOOR HARNESS (3)

HL-7

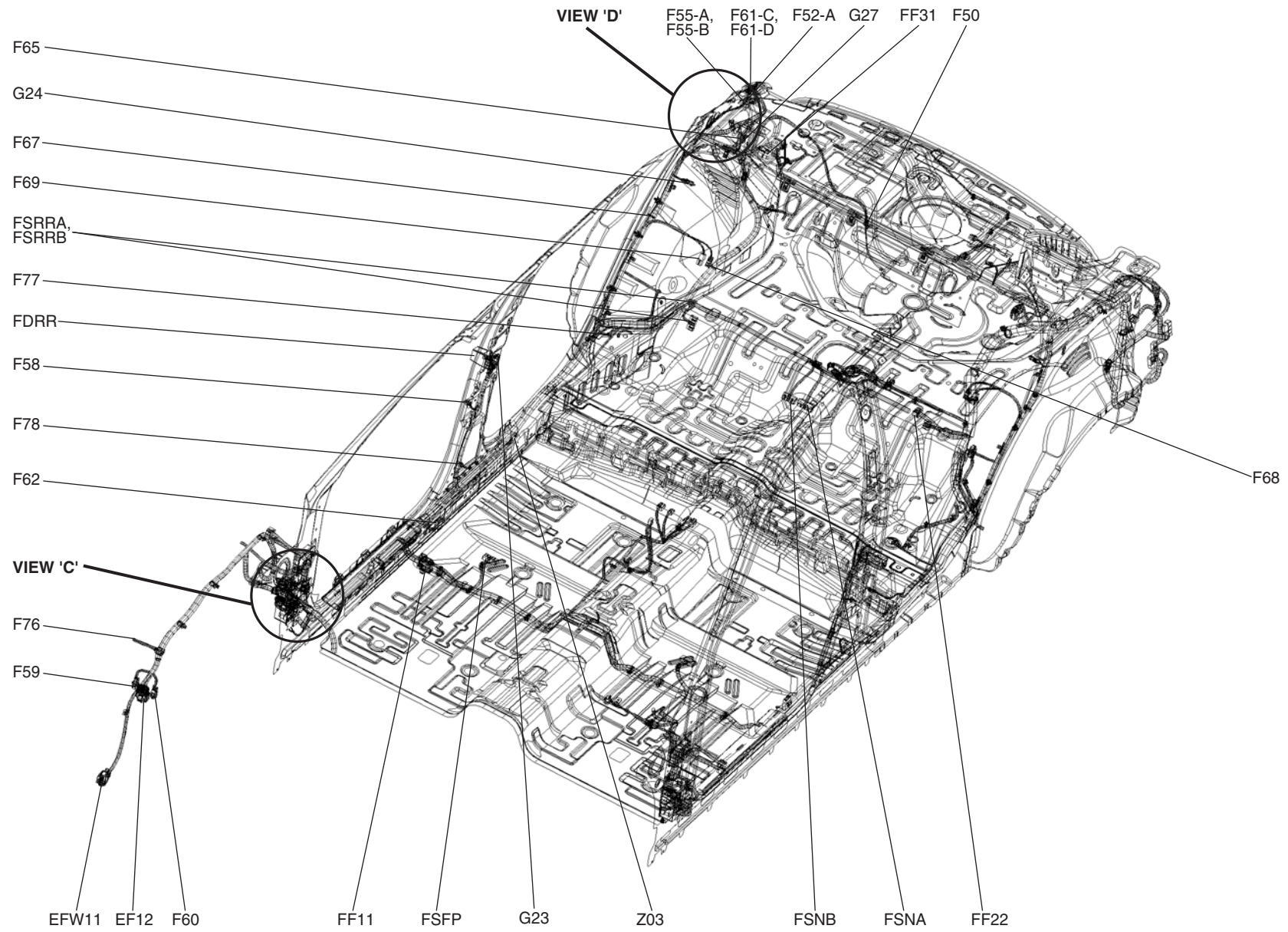

FLOOR HARNESS

FLOOR HARNESS (4)

HL-8

VIEW 'C'

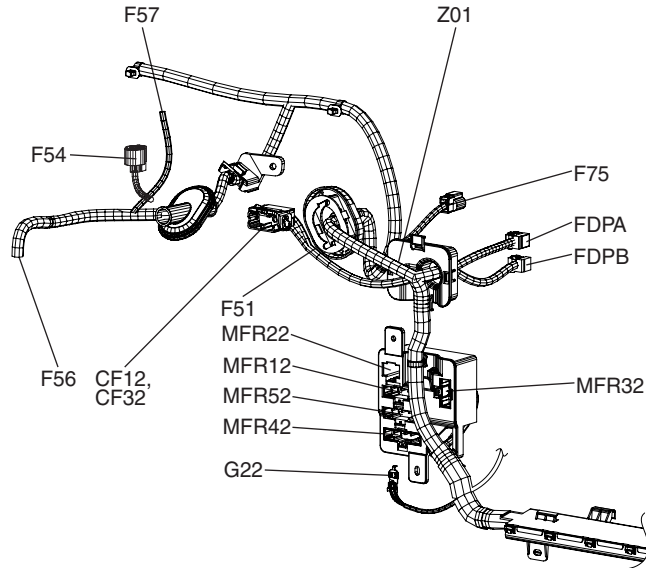

VIEW 'D'

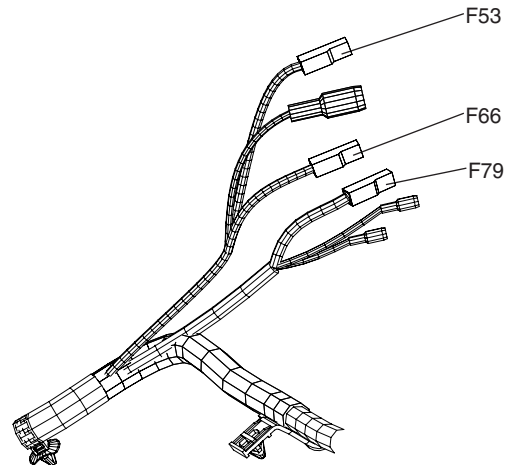

FLOOR RH HARNESS

- F50 Air Purifier Module
- F51 ATM Key Lock Control Module
- F52-A Front & Back Warning Module
- F53 Diversity Antenna Module
- F55-A ECS Control Module
- F55-B ECS Control Module
- F56 ABS/ESP Control Module
- F57 Front ECS-G Sensor RH
- F58 Front Door Switch RH
- F59 Front ECS Actuator RH
- F60 Front Wheel Sensor RH
- F62 Joint Connector
- F65 Rear ECS-G Sensor
- F66 Rear Defogger '+'
- F67 Rear Door Switch RH
- F68 Rear ECS Actuator RH
- F69 Rear Wheel Sensor RH
- F75 Side Repeater Lamp RH
- F80 Rear Defogger '-'
- CF12 Connection With CONTROL Harness
- EF12 Connection With ENGINE Harness
- EFW11 Connection With FRONT WARNING Harness
- FDPA Connection With FRONT DOOR RH Harness
- FDPB Connection With FRONT DOOR RH Harness
- FDRR Connection With REAR DOOR RH Harness
- FF11 Connection With FLOOR LH Harness
- FF31 Connection With FLOOR LH Harness
- FSFP Connection With FRONT SEAT RH Harness
- FSNA Connection With REAR SEAT Harness (W/O Rear Power Seat)
- FSNB Connection With REAR SEAT Harness (W/O Rear Power Seat)
- FSRRA Connection With REAR SEAT RH Harness (With Rear Power Seat)
- FSRRB Connection With REAR SEAT RH Harness (With Rear Power Seat)
- MFR12 Connection With MAIN Harness
- MFR22 Connection With MAIN Harness
- MFR32 Connection With MAIN Harness
- MFR42 Connection With MAIN Harness
- MFR52 Connection With MAIN Harness
- G22 Ground
- G23 Ground
- G24 Ground
- G26 Ground

CONTROL HARNESS (1)

G6DA

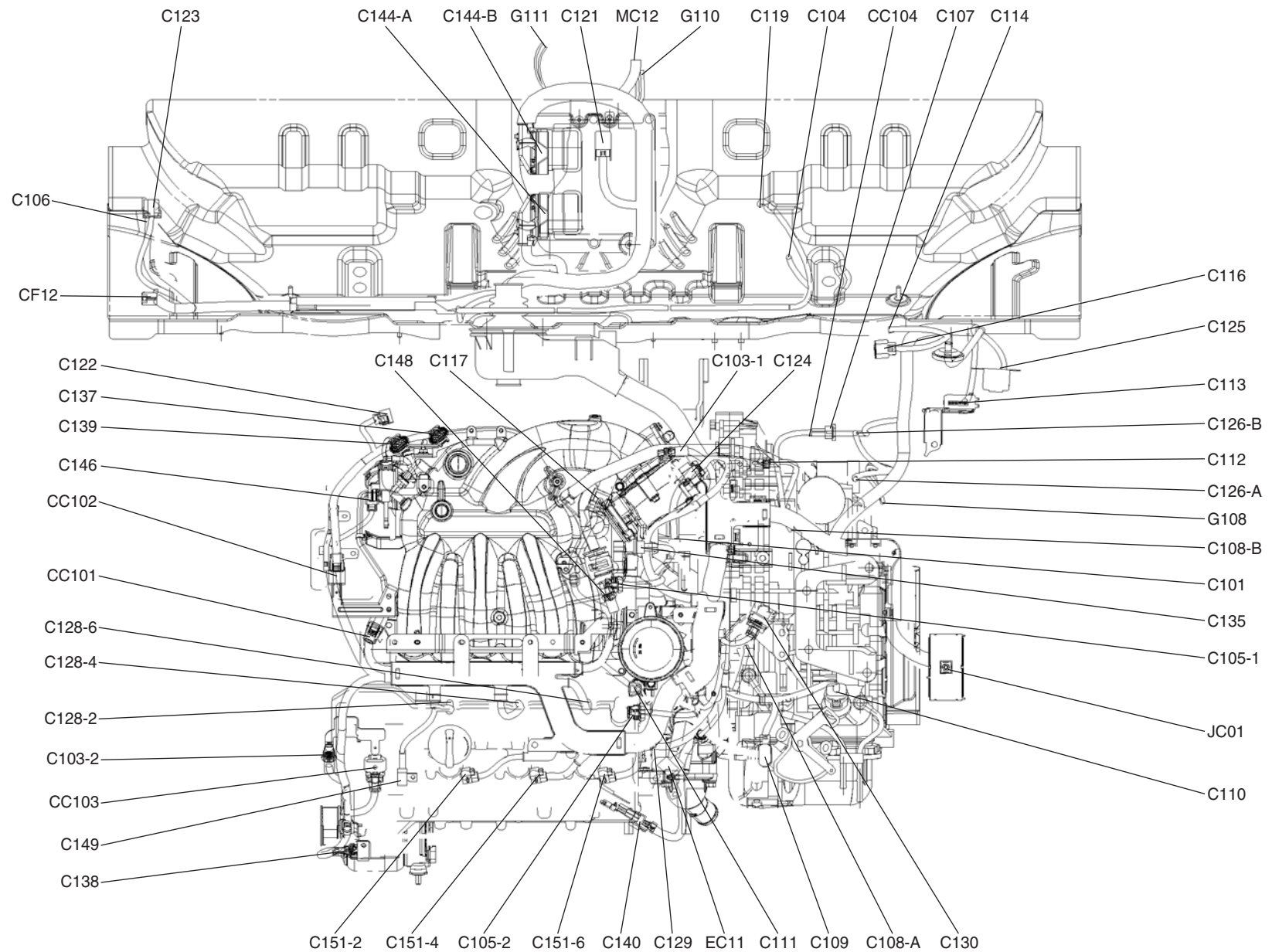

CONTROL HARNESS

CONTROL HARNESS (2)

HL-10

CONTROL HARNESS (G6DA)

C101	Engine Coolant Temperature Sensor & Sender	C139	Oxygen Sensor #3 (B1/S2)
C103-1	Knock Sensor #1	C140	Oxygen Sensor #4 (B2/S2)
C103-2	Knock Sensor #2	C144-A	PCM
C104	Adjustable Pedal Motor	C144-B	PCM
C105-1	Cam Shaft Position Sensor #1	C146	Variable Intake Manifold Valve
C105-2	Cam Shaft Position Sensor #2	C148	Purge Control Solenoid Valve
C106	Adjustable Pedal Twin Relay	C149	Condenser
C107	Brake Fluid Level Sensor	C151-2	Ignition Coil #2
C108-A	Pulse Generator 'A'	C151-4	Ignition Coil #4
C108-B	Pulse Generator 'B'	C151-6	Ignition Coil #6
C109	Transaxle Range Switch	CC101	Connection With IGNITION COIL EXT. Harness
C110	ATM Solenoid Valve	CC102	Connection With INJECTOR EXT. Harness
C111	Oil Pressure Switch	CC103	Connection With OCV EXT. Harness
C112	Vehicle Speed Sensor	CF12	Connection With FLOOR RH Harness
C113	Multipurpose Check Connector	EC11	Connection With BATTERY Harness
C114	Windshield Defogger	MC12	Connection With MAIN Harness
C116	Wiper Motor	JC01	Connection With E/R JUNCTION BOX Harness
C117	MAP Sensor	G108	Ground
C119	Accel Position Sensor	G110	Ground
C121	ATM Control Relay	G111	Ground
C122	Power Steering Pressure Sensor		
C123	Engine Control Relay		
C124	ETC Motor & Throttle Position Sensor		
C125	Front ESC-G Sensor LH		
C126-A	Pressure Sensor #1		
C126-B	Pressure Sensor #2		
C128-2	Injector #2		
C128-4	Injector #4		
C128-6	Injector #6		
C129	Crank Shaft Position Sensor		
C130	Mass Air Flow Sensor		
C135	Oil Temperature Sensor		
C137	Oxygen Sensor #1 (B1/S1)		
C138	Oxygen Sensor #2 (B2/S1)		

IGNITION COIL EXT. HARNESS

C151-1	Ignition Coil #1
C151-3	Ignition Coil #3
C151-5	Ignition Coil #5
C155	Condenser
CC101	Connection With CONTROL Harness

INJECTOR EXT. HARNESS

C128-1	Injector #1
C128-3	Injector #3
C128-5	Injector #5
CC102	Connection With CONTROL Harness

OCV EXT. HARNESS

C156-1	Oil Control Valve #1 (Right Bank)
C156-2	Oil Control Valve #2 (Left Bank)
CC103	Connection With CONTROL Harness

DOOR HARNESS (1)

HL-11

FRONT DOOR

REAR DOOR

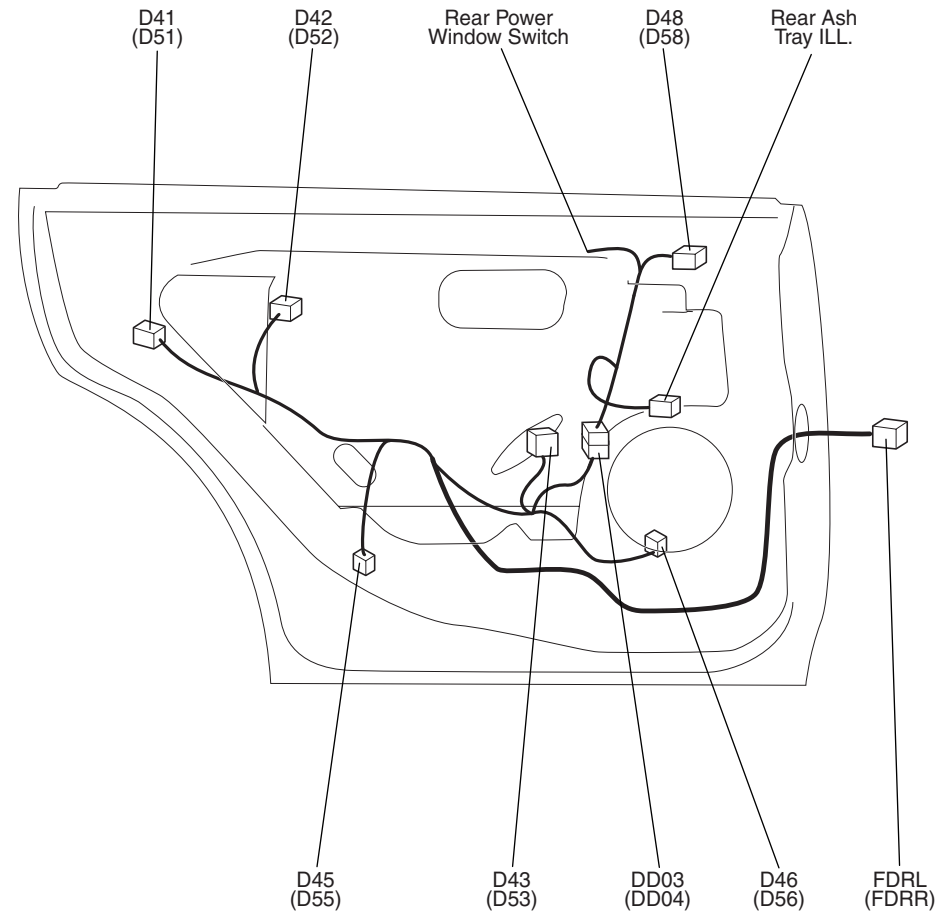
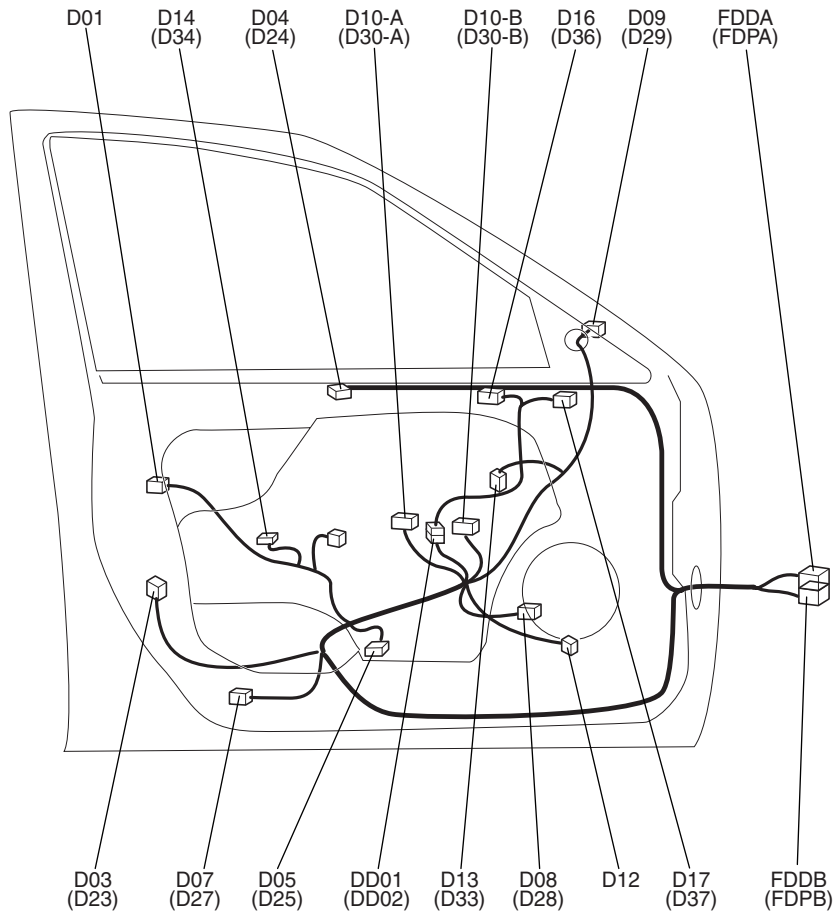

() : RIGHT

DOOR HARNESS

DOOR HARNESS (2)

HL-12

FRONT DOOR LH HARNESS

D01 Front Door Key Switch LH
D03 Front Door Lock Actuator LH
D04 Front PIC Outside Handle LH
D05 Front Safety Window Module LH
D07 Front Door Lamp LH
D08 Front Door Speaker LH
D09 Power Outside Mirror & Mirror Folding Motor LH
D10-A Power Window Main Switch
D10-B Power Window Main Switch
D12 Fuel Lid Opener & Trunk Lid Switch
D13 Front Safety Power Window LH
D14 Joint Connector
DD01 Connection With FRONT DOOR LH EXT. Harness
FDDA Connection With FLOOR LH Harness
Fddb Connection With FLOOR LH Harness

FRONT DOOR LH EXT. HARNESS

D16 Front Power Seat Switch LH
D17 Front Tweeter Speaker LH
DD01 Connection With FRONT DOOR LH Harness

REAR DOOR LH HARNESS

D41 Rear Door Lock Actuator LH
D42 Rear Safety Power Window LH
D43 Rear Safety Window Module LH
D45 Rear Door Lamp LH
D46 Rear Door Speaker LH
DD03 Connection With REAR DOOR LH EXT. Harness
FDRL Connection With FLOOR LH Harness

REAR DOOR LH EXT. HARNESS

D48 Rear Tweeter Speaker LH
DD03 Connection With REAR DOOR LH Harness

FRONT DOOR RH HARNESS

D23 Front Door Lock Actuator RH
D24 Front PIC Outside Handle RH
D25 Front Safety Window Module RH
D27 Front Door Lamp RH
D28 Front Door Speaker RH
D29 Power Outside Mirror & Mirror Folding Motor RH
D30-A Front Power Window Switch RH
D30-B Front Power Window Switch RH
D33 Front Safety Power Window RH
D34 Joint Connector
DD02 Connection With FRONT DOOR RH EXT. Harness
FDPA Connection With FLOOR RH Harness
FDPB Connection With FLOOR RH Harness

FRONT DOOR RH EXT. HARNESS

D36 Front Power Seat Switch RH
D37 Front Tweeter Speaker RH
DD02 Connection With FRONT DOOR RH Harness

REAR DOOR RH HARNESS

D51 Rear Door Lock Actuator RH
D52 Rear Safety Power Window RH
D53 Rear Safety Window Module RH
D55 Rear Door Lamp RH
D56 Rear Door Speaker RH
DD04 Connection With REAR DOOR RH EXT. Harness
FDRR Connection With FLOOR RH Harness

REAR DOOR RH EXT. HARNESS

D58 Rear Tweeter Speaker RH
DD04 Connection With REAR DOOR RH Harness

TRUNK HARNESS (1)

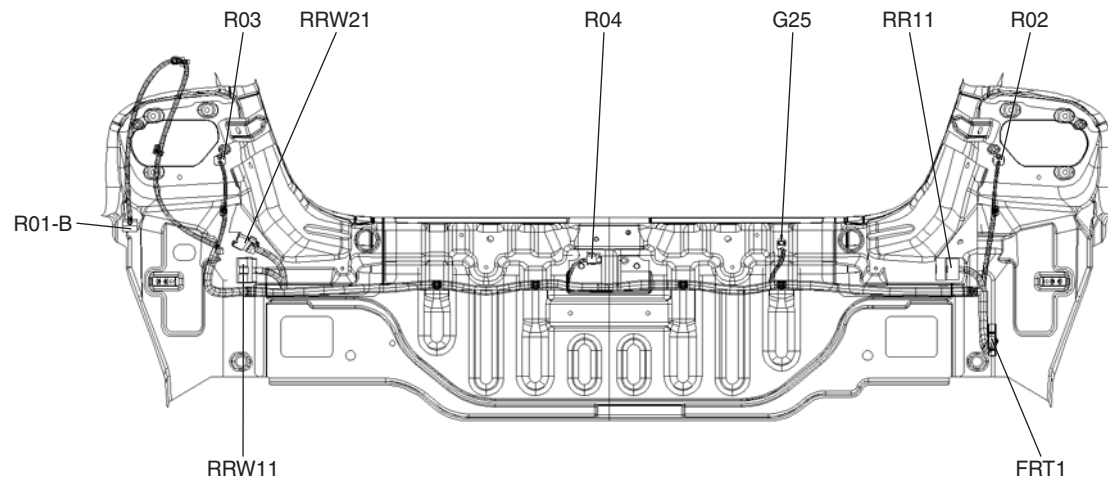

TRUNK ROOM HARNESS

- R01-B Front & Back Warning Module
- R02 Rear Combination Lamp LH
- R03 Rear Combination Lamp RH
- R04 PIC Trunk Antenna
- FRT1 Connection With FLOOR LH Harness
- RR11 Connection With TRUNK LID Harness
- RRW11 Connection With BACK WARNING Harness
- RRW21 Connection With BACK WARNING Harness
- G25 Ground

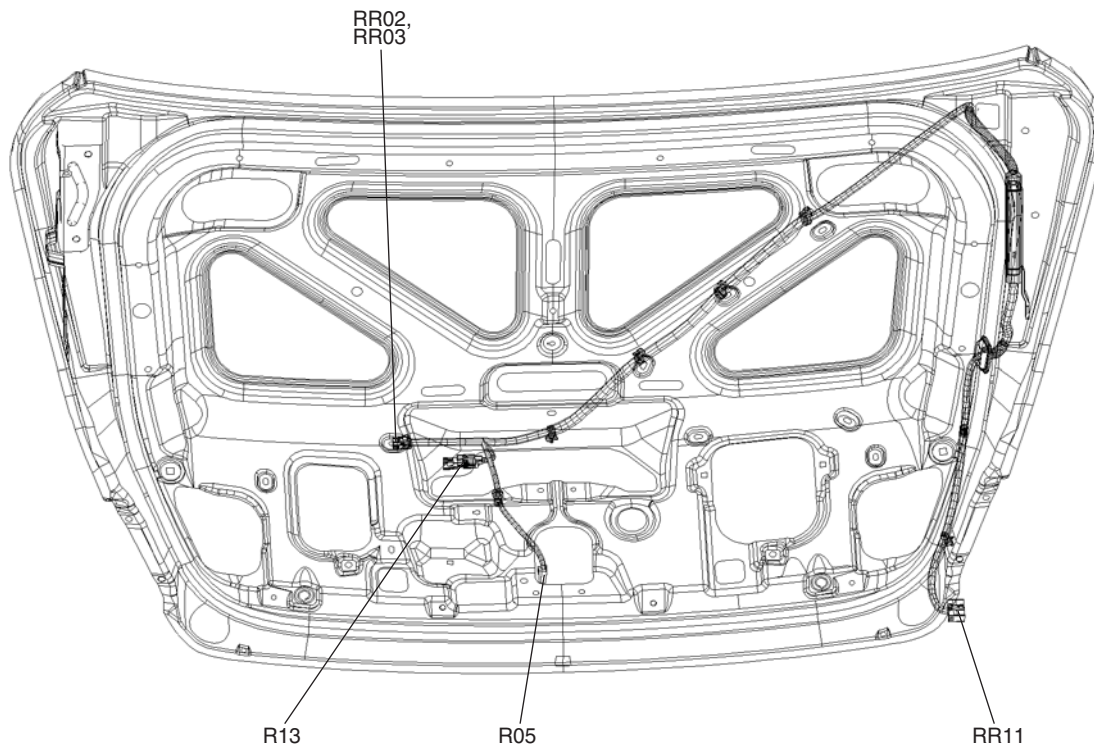

TRUNK LID HARNESS

- R05 Trunk Lid Latch
- RR02 Connection With TRUNK LID EXT. Harness
- RR11 Connection With TRUNK ROOM Harness

TRUNK LID EXT. HARNESS

- R06 Trunk Switch
- R07 License Lamp LH
- RR02 Connection With TRUNK LID Harness

ROOF HARNESS (1)

W/O SUNROOF

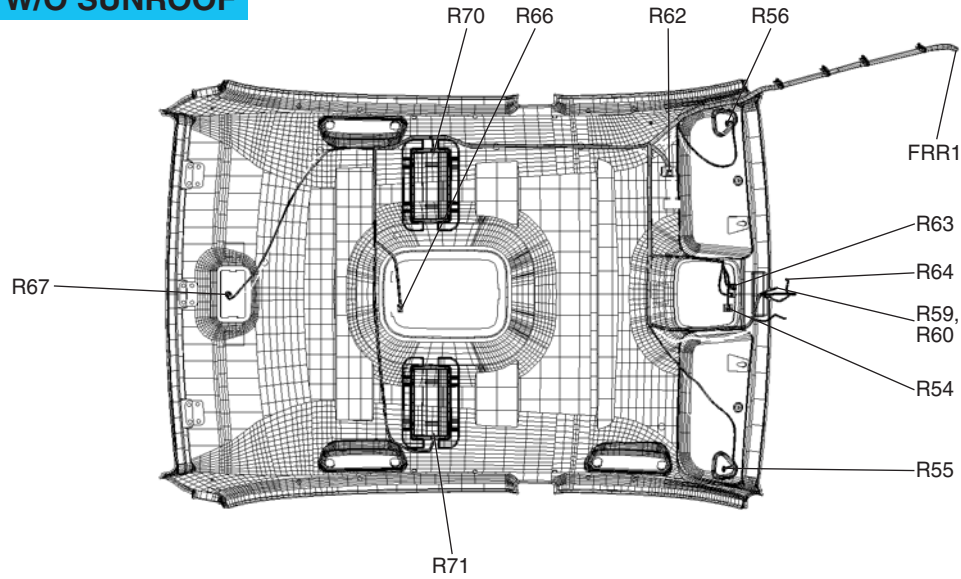

ROOF HARNESS

- R55 Sun Visor Lamp RH
- R56 Sun Visor Lamp LH
- R59 Electro Chromic Mirror
- R62 Joint Connector
- R63 Map Lamp
- R64 Rain Sensor
- R66 Room Lamp
- R68 Sunroof Switch
- RR01 Connection With SUNROOF EXT. Harness
- FRR1 Connection With FLOOR LH Harness

With SUNROOF

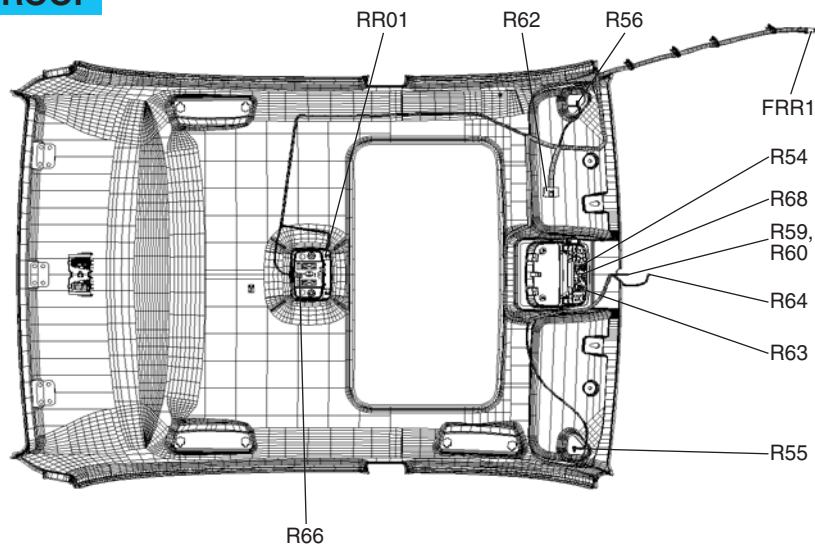

SUNROOF EXT. HARNESS

- R72 Sunroof Motor
- RR01 Connection With ROOF Harness

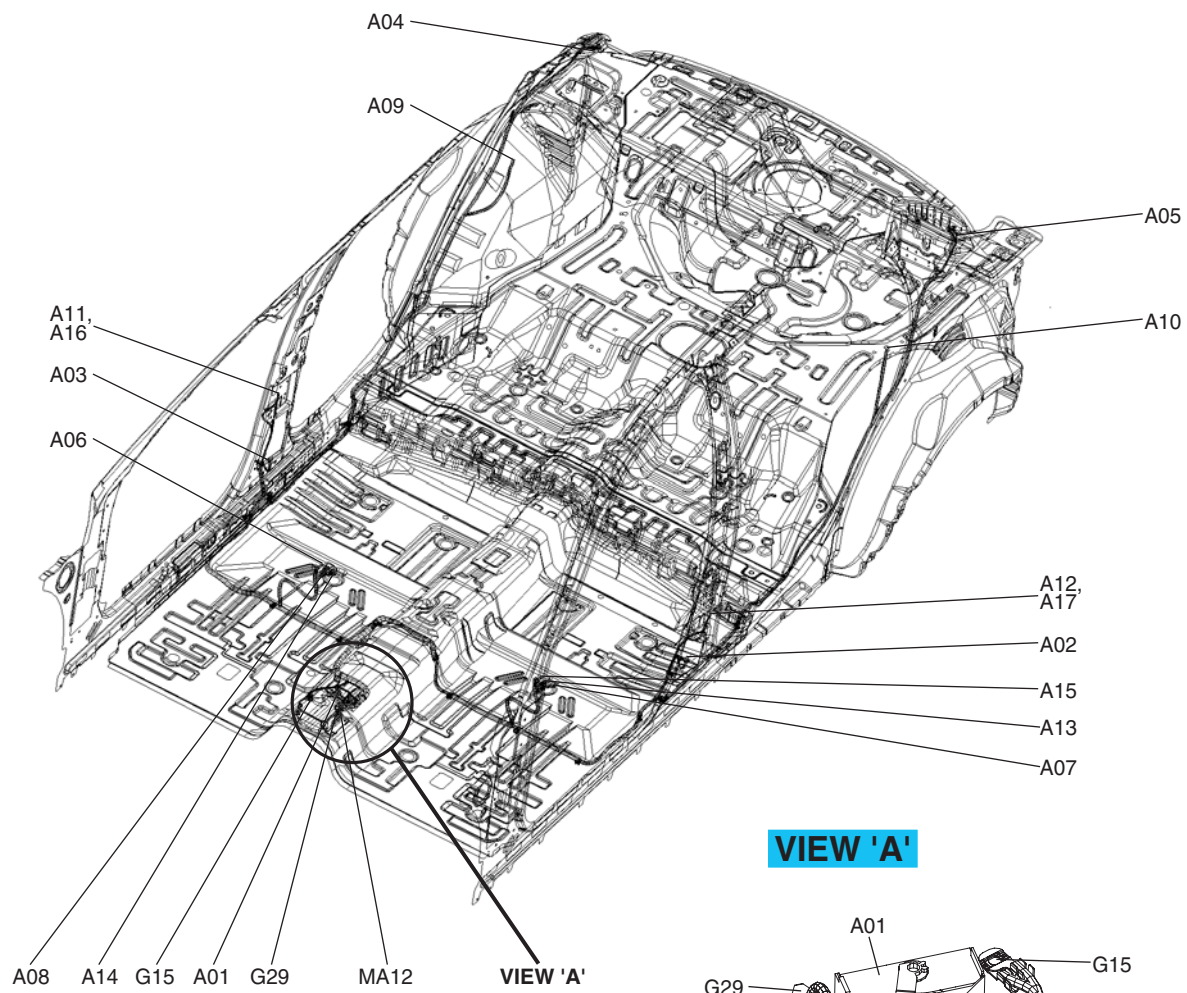

AIR BAG HARNESS

- A01 SRS Control Module
- A02 Driver Seat Belt Pretensioner
- A03 Passenger Seat Belt Pretensioner
- A04 Passenger Curtain Air Bag
- A05 Driver Curtain Air Bag
- A06 Front Side Air Bag RH
- A07 Front Side Air Bag LH
- A09 Rear Side Air Bag RH
- A10 Rear Side Air Bag LH
- A11 Passenger Side Impact Sensor
- A12 Driver Side Impact Sensor
- MA12 Connection With MAIN Harness
- MA32 Connection With MAIN Harness
- G15 Ground

VIEW 'A'

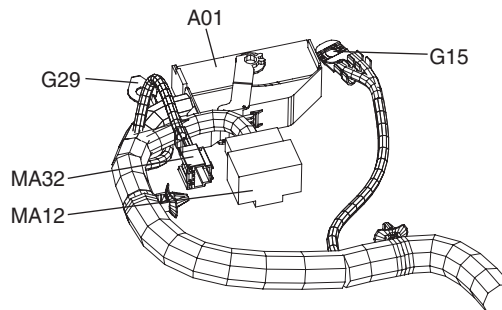

FRONT WARNING HARNESS/ BACK WARNING HARNESS (1)

FRONT BUMPER

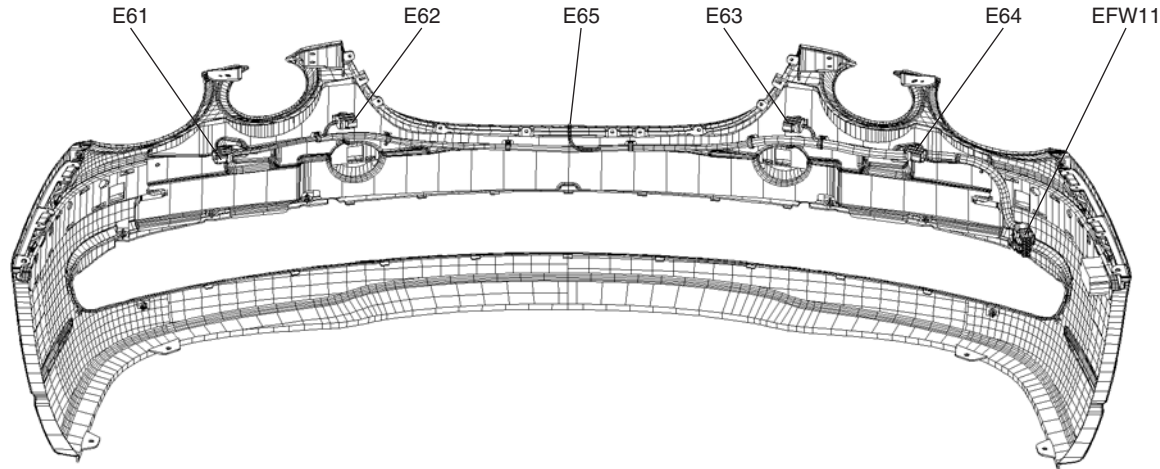

FRONT WARNING HARNESS

- E61 Front Side Warning Sensor LH
- E62 Front Center Warning Sensor LH
- E63 Front Center Warning Sensor RH
- E64 Front Side Warning Sensor RH
- EFW11 Connection With FLOOR RH Harness

REAR BUMPER

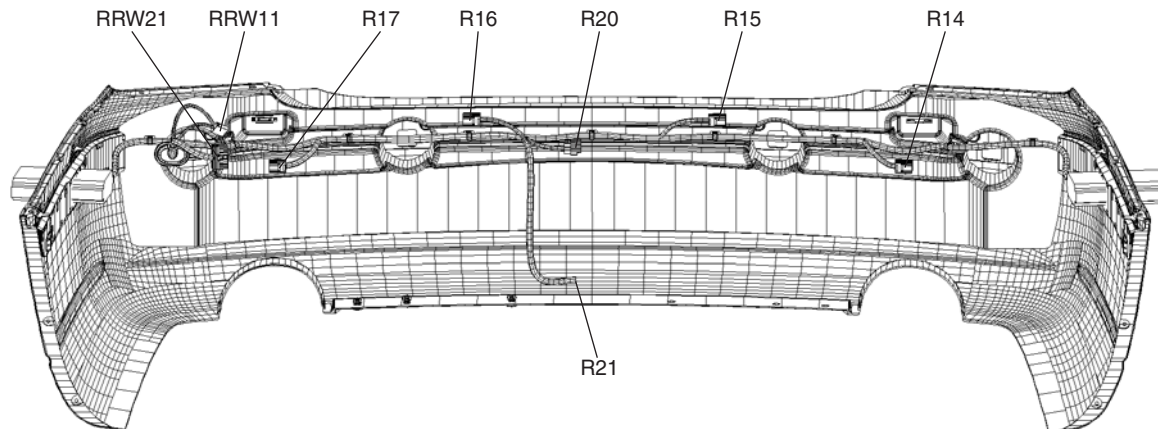

BACK WARNING HARNESS

- R14 Back Side Warning Sensor LH
- R15 Back Center Warning Sensor LH
- R16 Back Center Warning Sensor RH
- R17 Back Side Warning Sensor RH
- R20 PIC Bumper Antenna
- R21 Rear Fog Lamp
- RRW11 Connection With TRUNK ROOM Harness
- RRW21 Connection With TRUNK ROOM Harness

SEAT HARNESS (1)

HL-17

FRONT SEAT LH

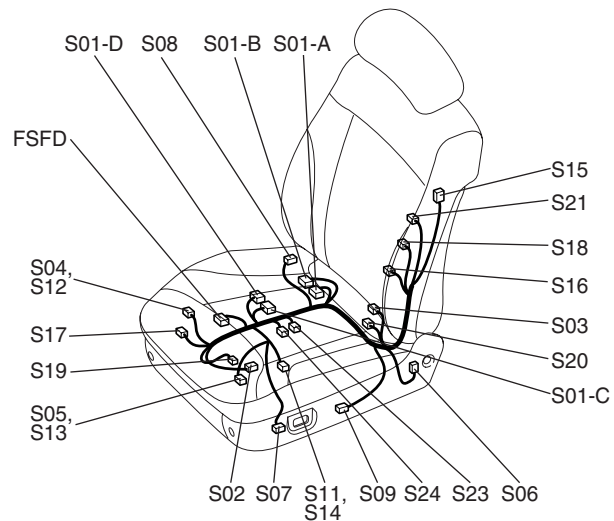

REAR SEAT (With Power Seat)

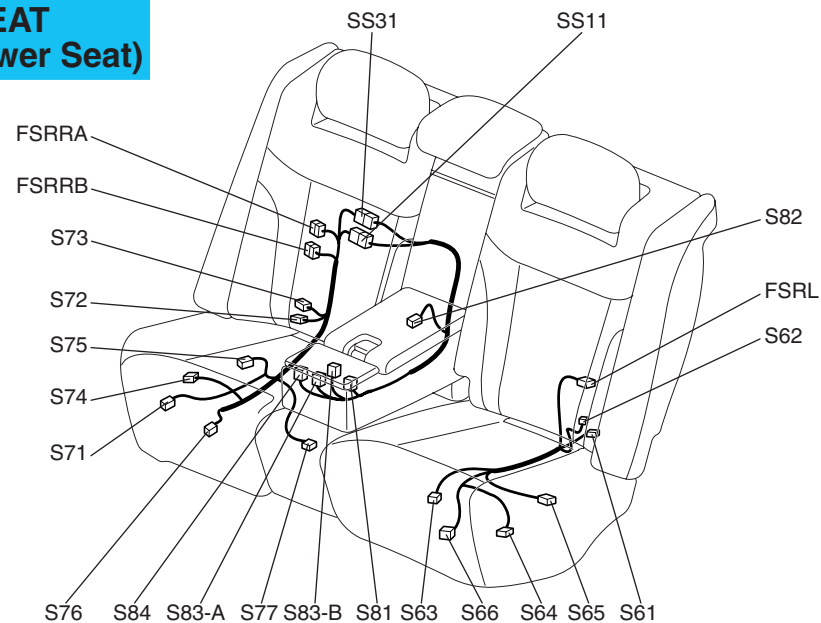

FRONT SEAT RH

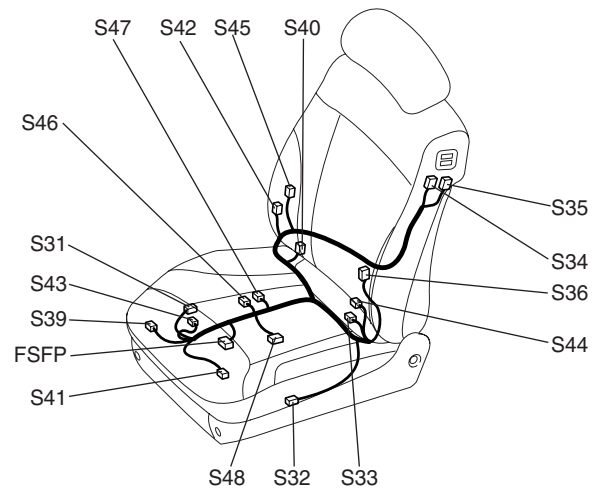

REAR SEAT (W/O Power Seat)

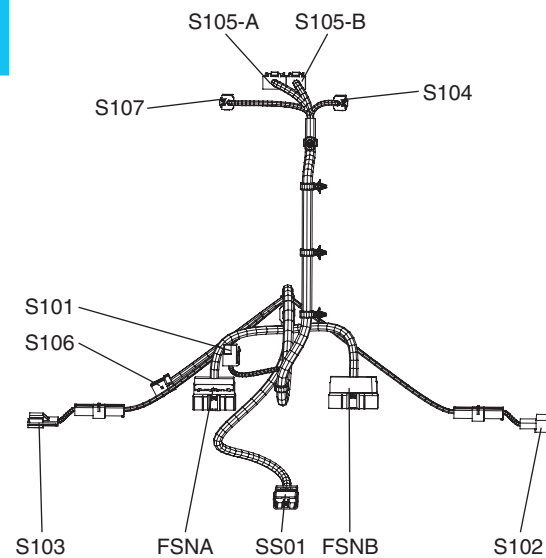

SEAT HARNESS

SEAT HARNESS (2)

HL-18

FRONT SEAT LH HARNESS

S01-A Power Seat Control Module
S01-B Power Seat Control Module
S01-C Power Seat Control Module
S01-D Power Seat Control Module
S02 Front Seat Warmer Module LH
S03 Front Cushion Warmer LH
S04 Height Motor (Rear)
S05 Front Slide Motor LH
S06 Front Recline Motor LH
S07 Front Lumbar Support Switch LH
S08 Front Recline Limit Switch LH
S09 Front Slide Limit Switch LH
S11 Height Motor (Front)
S12 Height Motor (Rear)
S13 Front Slide Motor LH
S14 Height Motor (Front)
S15 Front Lumbar Support Motor (AFT)
S16 Front Lumbar Support Motor (UP/DN)
S17 CCS Cushion Blower Motor LH
S18 CCS Recline Blower Motor LH
S19 CCS Module LH
S20 CCS Cushion Warmer LH
S21 CCS Recline Warmer LH
S23 Joint Connector
S24 Joint Connector
FSFD Connection With FLOOR LH Harness

REAR SEAT LH HARNESS (With Power Seat)

S61 Rear Cushion Warmer LH
S62 Rear Recline Warmer LH
S63 Rear Seat Warmer Module LH
S64 Rear Slide Motor LH
S65 Rear Slide Limit Switch
S66 Joint Connector
FSRL Connection With FLOOR LH Harness

FRONT SEAT RH HARNESS

S31 Front Seat Warmer Module RH
S32 Front Slide Limit Switch RH
S33 Front Cushion Warmer RH
S34 Walk In Recline Switch
S35 Walk In Slide Switch
S36 Front Recline Motor RH
S39 Front Slide Motor RH
S40 Front Recline Limit Switch RH
S41 CCS Cushion Blower Motor RH
S42 CCS Recline Blower Motor RH
S43 CCS Module RH
S44 CCS Cushion Warmer RH
S45 CCS Recline Warmer RH
S46 Joint Connector
S47 Joint Connector
S48 Front Power Seat Relay Box
FSFP Connection With FLOOR RH Harness

REAR SEAT RH HARNESS (With Power Seat)

S71 Rear Seat Warmer Module RH
S72 Rear Cushion Warmer RH
S73 Rear Recline Warmer RH
S74 Rear Slide Motor RH
S75 Rear Slide Limit Switch RH
S76 Joint Connector
S77 Rear Power Seat Relay Box
FSRRA Connection With FLOOR RH Harness
FSRRB Connection With FLOOR RH Harness
SS11 Connection With REAR CONSOLE Harness
SS31 Connection With REAR CONSOLE Harness

REAR CONSOLE HARNESS (With Power Seat)

S81 Rear Seat Warmer Switch LH
S82 Rear Power Outlet
S83-A Rear Console Switch
S83-B Rear Console Switch
S84 Rear Seat Warmer Switch RH
SS11 Connection With REAR SEAT RH Harness
SS31 Connection With REAR SEAT RH Harness

REAR SEAT HARNESS (W/O Power Seat)

S101 Rear Power Outlet
S102 Rear Recline Warmer RH
S103 Rear Recline Warmer LH
S104 Rear Seat Warmer Switch LH
S105-A Rear Console Switch
S105-B Rear Console Switch
S106 Joint Connector
S107 Rear Seat Warmer Switch RH
FSNA Connection With FLOOR RH Harness
FSNB Connection With FLOOR RH Harness
SS01 Connection With
REAR SEAT WARMER Harness

SEAT HARNESS

ANTENNA CABLE (1)

HL-19

