

INTRODUCTION (1)

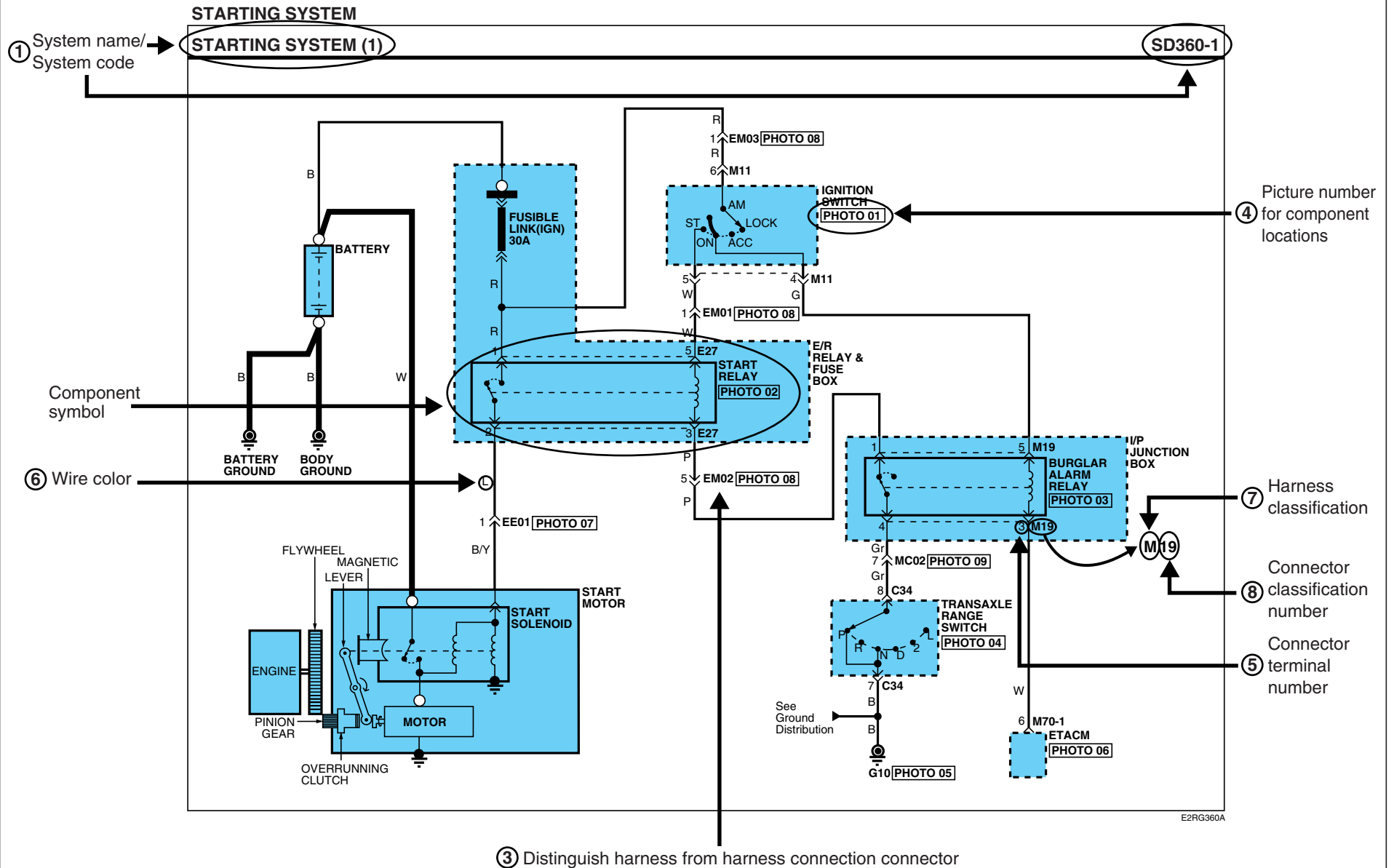

E2RG360A

INTRODUCTION

INTRODUCTION (2)

GI-2

STARTING SYSTEM

STARTING SYSTEM (2)

SD360-2

② Connector configurations (components)

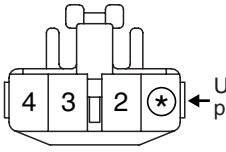
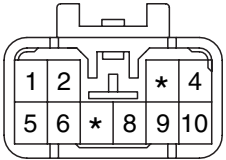
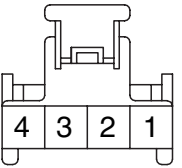
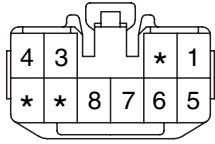
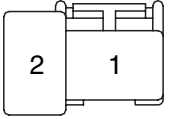
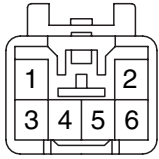
<p>M05</p>  <p>KET_090II_04F_W</p>	<p>M06</p>  <p>KET_090II_10M_W</p>	<p>M11</p>  <p>KUM_AR_04F_W</p>	<p>M13</p>  <p>KET_090II_10F_W</p>
<p>M67</p>  <p>AMP_PLM2_02F_B</p>	<p>M81</p>  <p>KET_090II_06M_W</p>	<p>BLANK</p>	<p>BLANK</p>

E2RG360B

Explanation of connector code

M05

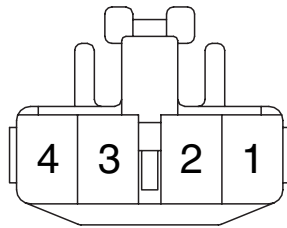

KET_090II_04F_W

a b c d e

a : Connector manufacturer

b : Terminal series number

c : The number of connector terminals

d : Connector distinguishing

Female Pin : F

Male Pin : M

e : Connector color abbreviations

B (Black)

Br (Brown)

G (Green)

Gr (Gray)

L (Blue)

R (Red)

W (White)

Y (Yellow)

① Pages by system/ Name of Schematic diagram

- Each page is consisted of circuits by system. This schematic diagram includes the path of electricity flow, connection condition for each switch, and the function of other relevant circuits at once. It is applicable to real service work.
- It is very important to understand relevant circuits exactly before troubleshooting diagnosis.
- Circuits by system depends upon part number and are indicated on schematic diagram index.

② Connector configuration (components)

- The connector figure of components in the schematic diagram by system is indicated on the last page of schematic diagram.
- It shows the front of the connector on the harness side when not to the harness connector. The terminal number on each connector can be obtained by following the pattern used in ⑤ connector view and numbering order. Unused terminals are marked with an asterisk (*).

③ Connector configurations (connection between harnesses)

- When connecting the harness with connector between harnesses, it shows female and male connectors and indicates them on the connector configurations group.

EM02

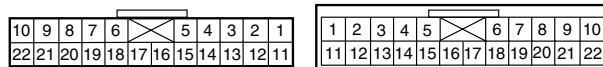

④ Component locations

- To find the components easily, a component locations diagram is indicated with "PHOTO NO" on the lower portion of the component name.
- To make it easy to distinguish connectors, the connector in the picture is indicated being installed in the vehicle.

PHOTO 03

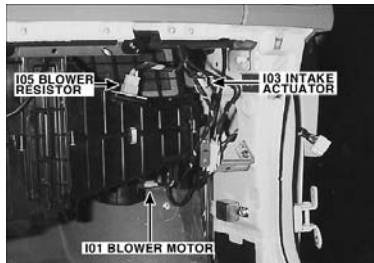

⑤ CONNECTOR VIEW AND NUMBERING ORDER

Female	Male	Remarks
		<p>It is not the shape of the connector housing, but the connector pin that distinguishes between male or female connectors. When numbering female and male connectors, refer to the numbering order in the following table. Some connectors may not follow this method of numbering order. For individual detailed numbering, refer to the CONNECTOR CONFIGURATIONS.</p>
		<p>Numbered in order from upper right to lower left</p> <p>Numbered in order from upper left to lower right</p>

NOTE

UNLESS OTHERWISE STATED, ALL CONNECTOR VIEWS ARE FROM THE TERMINAL SIDE OF THE CONNECTOR.

INTRODUCTION

INTRODUCTION (4)

GI-4

⑥ WIRE COLOR ABBREVIATIONS

The following abbreviations are used to identify wire colors in the circuit schematics.

Symbol	Color of wire	Symbol	Color of wire
B	Black	O	Orange
Br	Brown	P	Pink
G	Green	R	Red
Gr	Gray	W	White
L	Blue	Y	Yellow
Lg	Light Green	Pp	Purple
T	Tan	LI	Light Blue

* **(Y/B)**: Black stripe with yellow ground (2 colors)

↑ ↑
the color of the color of
background stripe

⑦ HARNESS CLASSIFICATION

Electrical wiring connectors are classified according to the wiring parts in the Harness Layouts.

Symbol	Harness name	Location
E	Engine, Battery harness	Engine compartment
M	Main, Glove Box EXT. harness	Passenger compartment, Floor
F	Floor, Console EXT. harness	Floor
C	Control, Injector EXT. harness	Engine compartment, Passenger compartment
R	Roof, Sunroof, Tail gate harness	Roof, Tail gate
A	Air bag, A/C harness	Under crash pad and Floor
D	Door harness	Door

* It depends on vehicles, it is necessary to check the harness name symbol on the harness layouts for detailed symbol.

⑧ CONNECTOR IDENTIFICATION

A connector identification symbol consists of a wiring harness location classification symbol corresponding to a wiring harness location and number corresponding to the connector. These connector locations can be found in the HARNESS LAYOUTS.

For example:

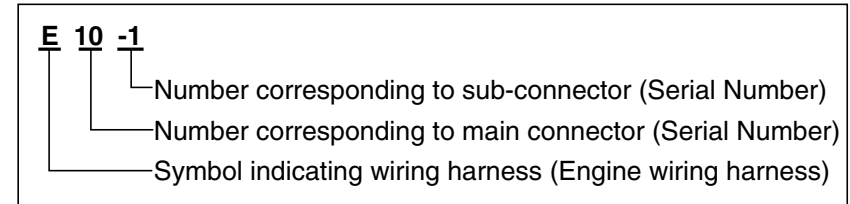

NOTE

Connectors which connect each wiring harness are represented by the following symbols.

For example:

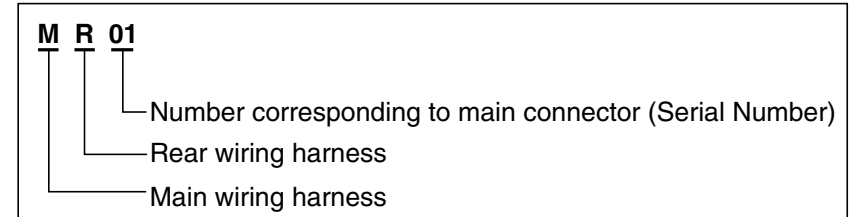

JUNCTION BLOCK IDENTIFICATION

A junction block identification symbol consists of a wiring harness location classification symbol corresponding to a wiring harness location and number corresponding to the connector in the junction block.

For example:

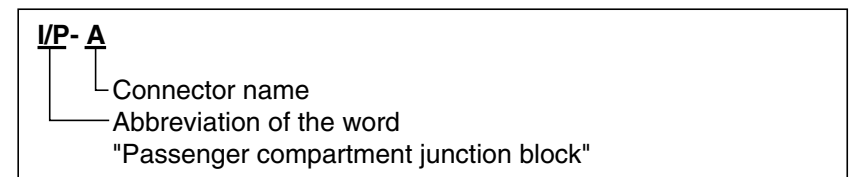

HARNESS LAYOUTS

Harness layouts show the routing of the major wiring harnesses, the in-line connectors and the splices between the major harnesses. These layouts will make electrical troubleshooting easier.

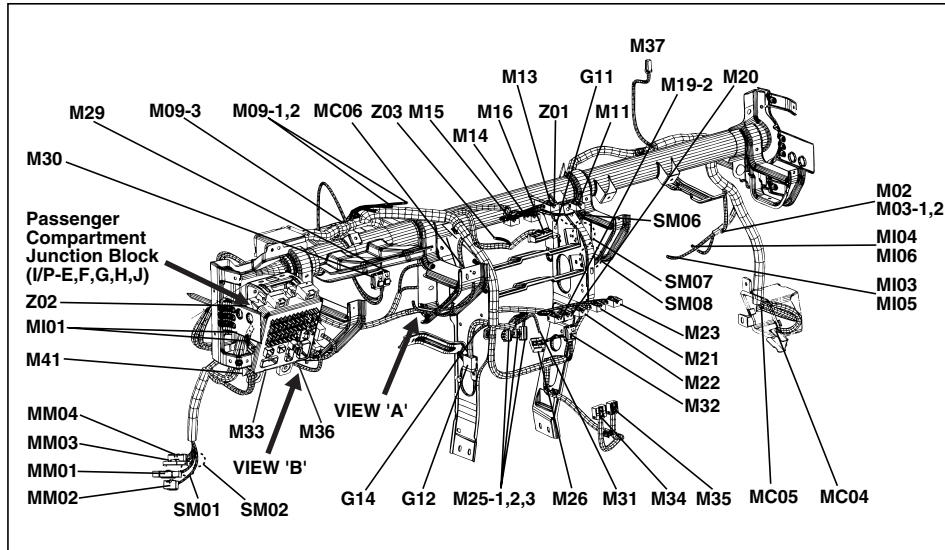









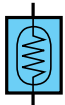

SYMBOLS (1)

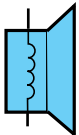
Section	Symbol	Meaning	Section	Symbol	Meaning	Section	Symbol	Meaning	Section	Symbol	Meaning
C O M P O N E N T		A solid line means the entire component is shown.	C O N N E C T O R		Shows the name of each connector on the component location index for reference. Indicates the number of corresponding terminal. (Only relevant terminal on the corresponding schematic diagram).	S H I E L D W I R E		This represents RFI (Radio Frequency Interference) Shielding around a wire. The shielding is always connected to ground.	L A M P		Double filament
		A broken line indicates only part of the component is shown.			The dashed-line means each of two wires connect with same connector(E35)			Single filament			
		This means the connector connects directly to the component.	W I R E		A wavy line means the wire is broken but is to be continued.	J O I N T C O N N E C T O R		This is a connector showing the joining wires.	D I O D E		Diode
		This indicates the connector connects to a lead (pigtail), wired directly to the component.			Wire insulation is yellow with a red strip.			Zener diode			
		This indicates a screw terminal on the component.	S P L I C E S		Current path is continued on the same page or another page. The arrow shows the direction of current flow. You should look for the "A" in the marked position.	S O W B L O W		Power supplied at all times. Name Capacity	T R		NPN
		This ground symbol (dot and 3 lines overlapping the component) means the housing of the component is attached to a metal part of the vehicle.			A wire connects to another circuit. The wire is shown again on that circuit which the arrow is pointing.			PNP			
		This indicates a screw terminal on the component.	G R O U N D		Wire choices for options or different models are labeled and shown with a "choice" bracket like this.	F U S E		This means power is supplied with the ignition on position. This means the short bar connects to other fuses. Identification Current rating	G E N E R A L C O M P O N E N T S Y M B O L		These switches move together: a dashed line shows a mechanical connection between them.
		This ground symbol (dot and 3 lines overlapping the component) means the housing of the component is attached to a metal part of the vehicle.			Splices are numbered and shown as a dot with circle. The exact location and connection of these splices may vary among vehicles.			Control battery power at all times			Switch (1 contact point)
	The name of the component appears next to its upper right corner. Shows the number of pictures for component location.			This symbol means the end of the wire is attached to a metal part of the vehicle.	C O N T R O L B A T T E R Y P O W E R		Heater				

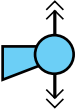
SYMBOLS

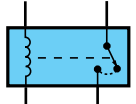
SYMBOLS (2)

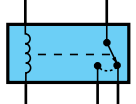
GI-7

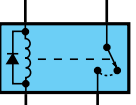
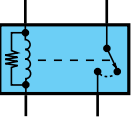
Section	Symbol	Meaning	Section	Symbol	Meaning
GENERAL COMPONENTS SYMBOL		Sensor	GENERAL COMPONENTS SYMBOL		Condenser
		Sender			Speaker
		Injector			Horn, Buzzer, Siren, Chime Bell
		Solenoid	RELAY		Normally open contact
		Motor			This is a relay shown with no current flowing through its coil. When a current flows through coil, contact will toggle.
		Battery			Diode interior relay
				Resistance interior relay	

TROUBLESHOOTING INSTRUCTIONS (1)

GI-8

TROUBLESHOOTING INSTRUCTIONS

TROUBLESHOOTING PROCEDURES

The following five-step troubleshooting procedure is recommended.

1. Verify the customer's complaints

Turn on all the components in the problem circuit to check the accuracy of the customer's complaints. Note the symptoms.

Do not begin disassembly or testing until you have narrowed down the probable causes.

2. Read and analyze the schematic diagram

Locate the schematic for the problem circuit. Determine how the circuit is supposed to work by tracing the current paths from the power source through the system components to ground. If you do not understand how the circuit should work, read the circuit operation text. Also check other circuits that share with the problem circuit. The name of circuits that share the same fuse, ground, or switch, for example, are referred to on each diagram. Try to operate any shared circuits you did not check in step 1. If the shared circuit works, the shared wiring is okay, and the cause must be within the wiring used only by the problem circuit.

If several circuits fail at the same time, the fuse or ground is a likely cause.

3. Inspect the circuit/ component with the problem isolated

Make a circuit test to check the diagnosis you made in step 2. Remember that a logical, simple procedure is the key to efficient troubleshooting. Narrow down the probable causes using the troubleshooting hints and system diagnosis charts.

Test for the most likely cause of failure first.

Try to make tests at points that are easily accessible.

4. Repair the problem

Once the problem is found, make the necessary repairs.

5. Make sure the circuit works

Repeat the system check to be sure you have repaired the problem. If the problem was a blown fuse, be sure to test all of the circuits on that fuse.

TROUBLESHOOTING EQUIPMENT

VOLTMETER AND TEST LAMP

Use a test lamp or a voltmeter on circuits without solidstate units and use a test lamp to check for voltage. A test lamp is made up of a 12-volt light bulb with a pair of leads attached. After grounding one lead, touch the other lead to various points along the circuit where voltage should be present.

When the bulb goes on, there is voltage at the point being tested.

CAUTION

A number of circuits include solid-state modules, such as the Engine Control Module(ECM), used with computer command control injection. Voltage in these circuits should be tested only with a 10-megaohm or higher impedance digital multimeter. Never use a test lamp on circuits that contain solid state modules. Damage to the modules may result.

A voltmeter can be used in place of a test lamp. While a test lamp shows whether the voltage is present or not, a voltmeter indicates how much voltage is present.

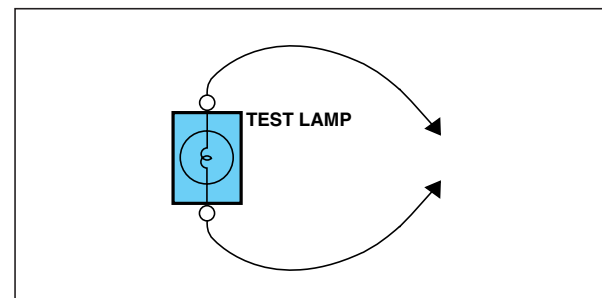
**SELF-POWERED TEST LAMP AND OHMMETER**

Use a self-powered test lamp or an ohmmeter to check for continuity.

The ohmmeter shows how much resistance there is between two points along a circuit. Low resistance means good continuity.

TROUBLESHOOTING INSTRUCTIONS

TROUBLESHOOTING INSTRUCTIONS (2)

GI-9

CAUTION

Never use a self-powered test lamp on circuits that contain solid state modules. Damage to these modules may result.

An ohmmeter can be used in place of a self-powered test lamp. The ohmmeter shows how much resistance there is between two points along a circuit. Low resistance means good continuity.

Circuits which include any solid-state devices should be tested only with a 10-megaohm or higher impedance digital multimeter. When measuring resistance with a digital multimeter, the battery negative terminal should be disconnected. Otherwise, there may be incorrect readings. Diodes and solid-state devices in a circuit can make an ohmmeter give a false reading. To find out if a component is affecting a measurement, take one reading, reverse the leads and take a second reading. If different the solid-state device is affecting the measurement.

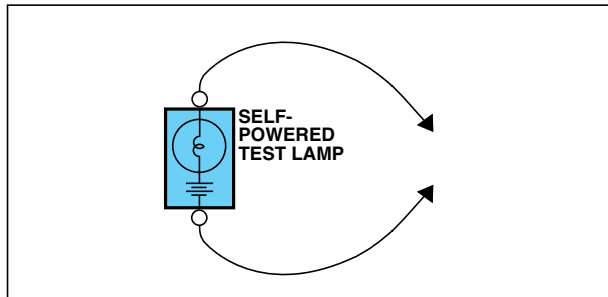

JUMPER WIRE WITH FUSE

Use a jumper wire with a fuse to by-pass an open circuit.

A jumper wire is made up of an in-line fuse holder connected to a set of test leads. This tool is available with small clamp connectors providing adaption to most connectors without damage.

CAUTION

Do not use a fuse with a higher rating than the specified fuse that protects the circuit being tested. Do not use this tool in any situation to substitute an input or output at the solid-state control module, such as ECM, TCM, etc.

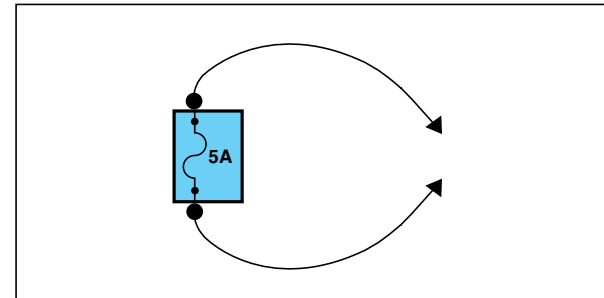

SHORT FINDER

A short finder is available to locate a short to ground. The short finder creates a pulsing magnetic field in the shorted circuit and shows you the location of the short through body trim or sheet metal.

TROUBLESHOOTING TEST

1. TESTING FOR VOLTAGE

This test measures voltage in a circuit. When testing for voltage at a connector, you do not have to separate the two halves of the connector. Instead, probe the connector from the back(backprobe). Always check both sides of the connector because dirt and corrosion between its contact surfaces can cause electrical problems.

- A. Connect one lead of a test lamp or voltmeter to a ground. If you are using a voltmeter, be sure it is the voltmeter's negative test lead you have connected to ground.
- B. Connect the other lead of the test lamp or voltmeter to a selected test point(connector or terminal).
- C. If the test lamp glows, there is voltage present. If you are using a voltmeter, note the voltage reading. A loss of more than 1 volt from specification indicates a problem.

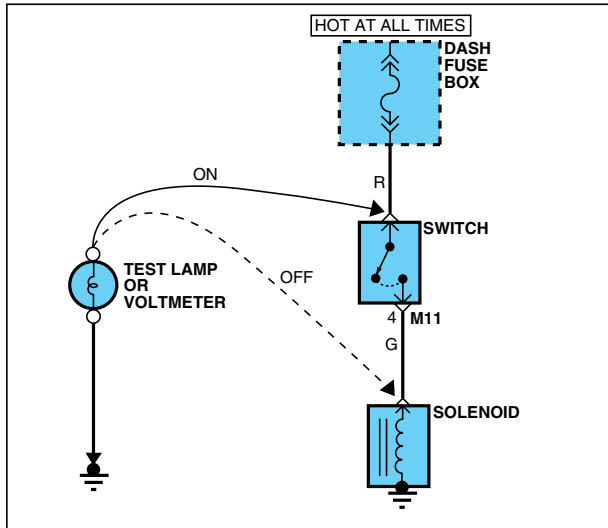

2. TESTING FOR CONTINUITY

- Disconnect the battery negative terminal.
- Connect one lead of a self-powered test lamp or ohmmeter to one end of the part of the circuit you wish to test. If you are using an ohmmeter, hold the leads together and adjust the ohmmeter to read zero ohms.
- Connect the other lead to the other end.
- If the self-power test lamp glows, there is continuity. If you are using an ohmmeter, low or zero resistance means good continuity.

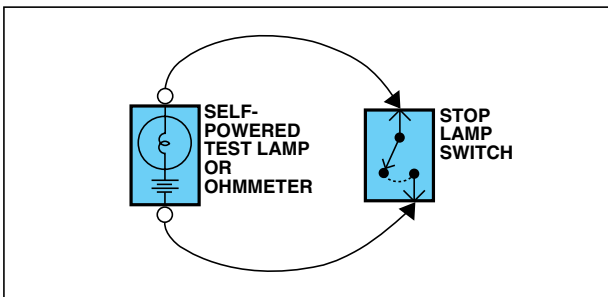

3. TESTING FOR SHORT TO GROUND

- Disconnect the battery negative terminal.
- Connect one lead of a self-powered test lamp or an ohmmeter to the fuse terminal on the load side.
- Connect the other lead to a ground.
- Beginning near the fuse block move the harness from side to side. Continue this procedure (about six inches apart) while watching the self-powered test lamp or ohmmeter.
- When the self-powered test lamp glows, or ohmmeter registers, there is a short to a ground in the wiring near that point.

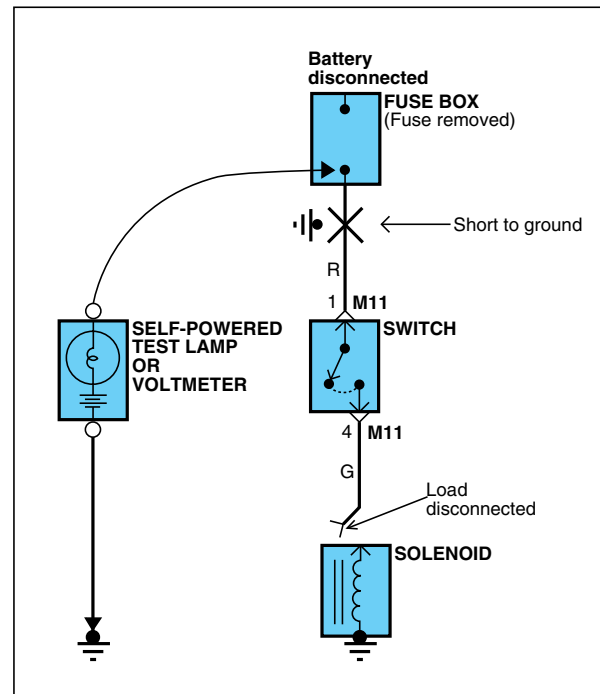

4. TESTING FOR A SHORT WITH A SHORT FINDER

- A. Remove the blown fuse. Leave the battery connected.
- B. Connect the short finder across the fuse terminals.
- C. Close all switches in series in the circuit that is being testing.
- D. Turn on the short circuit locator. It sends pulses of current to the short.
This creates a pulsing magnetic field around the wiring between the fuse box and the short.
- E. Beginning at the fuse box, slowly move the short finder along the circuit wiring. The meter will show current pulses through sheet metal and body trim. As long as the meter is between the fuse and the short, the needle will move with each current pulse. Once the meter is moved past the point of the short, the needle will stop moving. Check around this area to locate the cause of the short circuit.

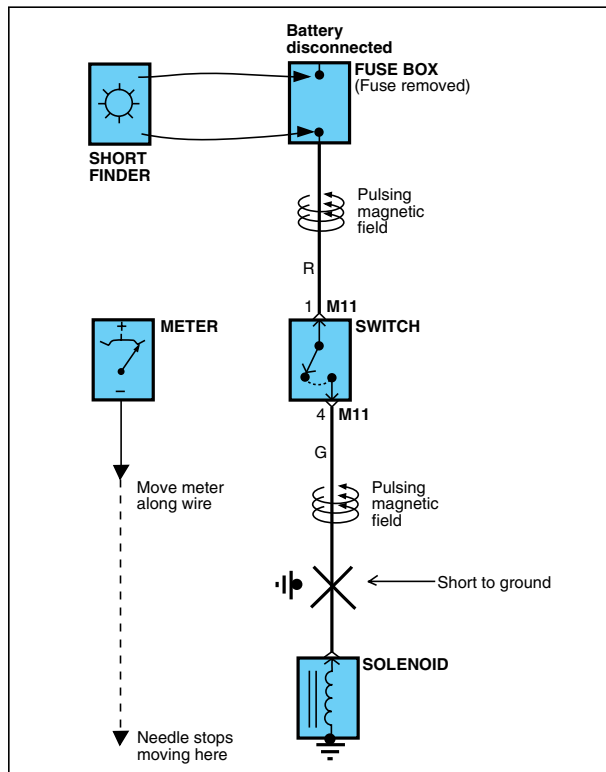

WIRING REPAIR (1)

* REFERENCE SERVICE TOOLS

Tool Number	Tool Name
TRK00A	Wiring Repair Kit (Standard Kit)
TRK001	Wire Stripper Set
TRK002	Remover Tool Set
TRK003	Terminal Tension Gauge Set
TRK004	Cable Tie Set
TRK005	Shrink Tube Set
TRK006	Jump Connector Kit(A)
TRK007~10	General Connector Kit(B~E)
TRK011	Terminal With Lead Wire Kit(F)
TRK012	Composition Kit(G)
TRK013	Lead Wire Set
TRK014	Carrying Case
TRK015	User's Guide & Parts Information
TRK016	Inner Box(Large)
TRK017	Inner Box(Small)
TRK018	Solder

* For more details, refer to the User's guide & parts Information of the Wiring Repair Kit (Pub. No. : OSG200208).

* Wiring Repair Kit

[Standard Kit (TRK00A)]

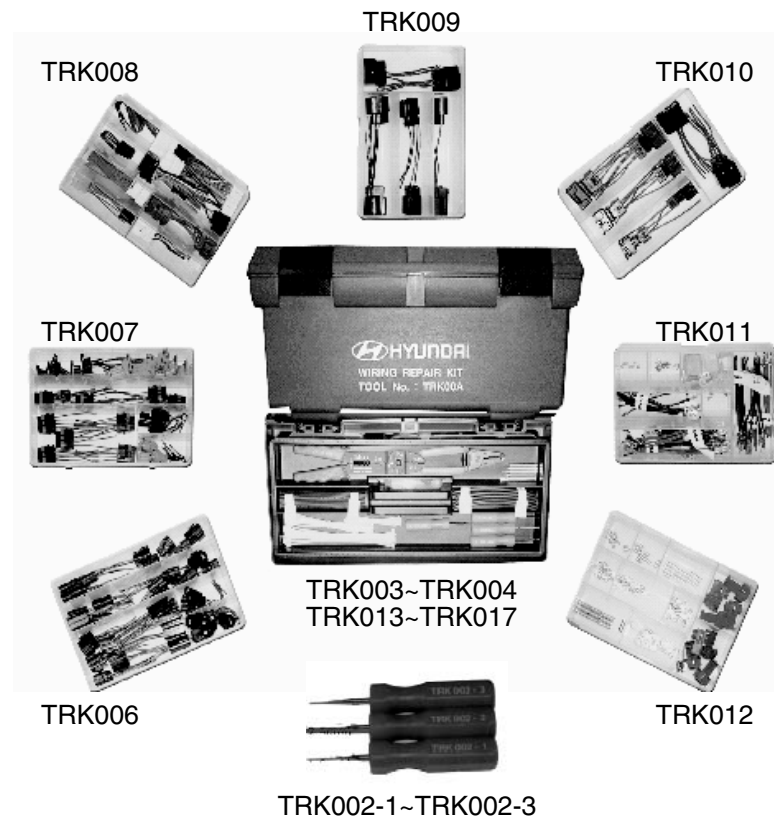

* Optional Items



REWORK PROCEDURE

1. Use of Wire stripper set (TRK001)

- 1) Disconnect the battery cable.
- 2) Choose the correct clamping slot for the wire and strip off the wire coat.
- ⦿ If the incorrect crimping slot is used, the terminal may be damaged and may not fit into the connector.

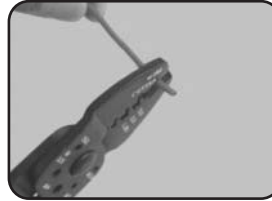

2. Use of Remover tool set (TRK002)

► **Flat tip type** : Removal of single locking male/female terminal from the connector.

- 1) Remove the front or rear retainer (holder, stopper) of the connector.



- 2) Ensure that the tip of the tool is inserted into the gap between the elastic arm of key and terminal.



- 3) Remove the terminal and check the terminal condition, if there is a damaged, replace it with a new terminal.

► **Double tip type** : Removal of double locking male/female terminal from the connector.



3. Use of Terminal tension gauge set (TRK003)

- 1) Select the tension gauge that matches the female terminal to be checked.



- 2) Insert a tension gauge into the female terminal and check the terminal condition. (as shown in the photograph)



⦿ If the tension of female terminal is not tight enough, remove it and replace the terminal and wire assembly (including seal).



4. Use of Ring terminal (TRK012-4)

1) Strip off about 5mm of the wire coat at the end of the wire.



2) Joint the stripped wire with ring terminal and crimp using wire stripper.

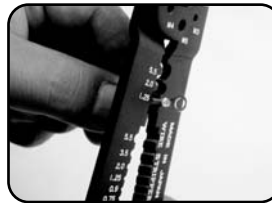

3) Put the shrink tube over the connection area and shrink the tube using electrical hot gun.



5. Use of Inline solder (TRK012-5) and Shrink tube set (TRK005)

1) Strip off about 5mm of the wire coat at the end of the wires.



2) Insert each wire into the opposite ends of the inline solder and crimp using wire stripper.

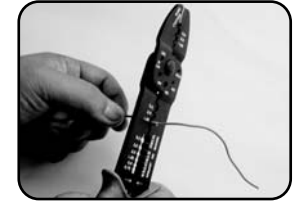

3) Put the shrink tube over the connection area and shrink the tube using electrical hot gun.



◎ Shrink tube should be securely wrapped around the inline solder area.

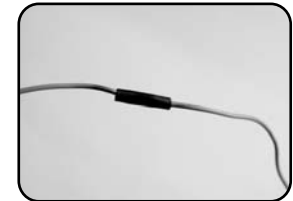

6. Use of Terminal with lead wire kit (TRK011)

- 1) Remove the damaged connector and terminal using remover tool.



- 2) Select the right wire, which is fitted with the terminal specification from terminal with lead wire box and cut of the end of wire using wire stripper.

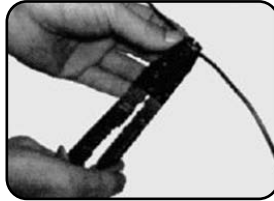

- 3) Put the end of each cut off wire in the middle of the splice joint terminal and compress using wire stripper.

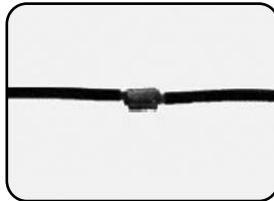

- 4) Put the shrink tube over the connection area and shrink the tube using electrical hot gun.

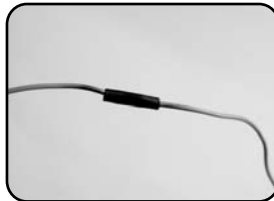

- 5) Insert the terminal with lead wire into the connector.



BODY CONTROL MODULE (BCM BOX)

<FRONT>

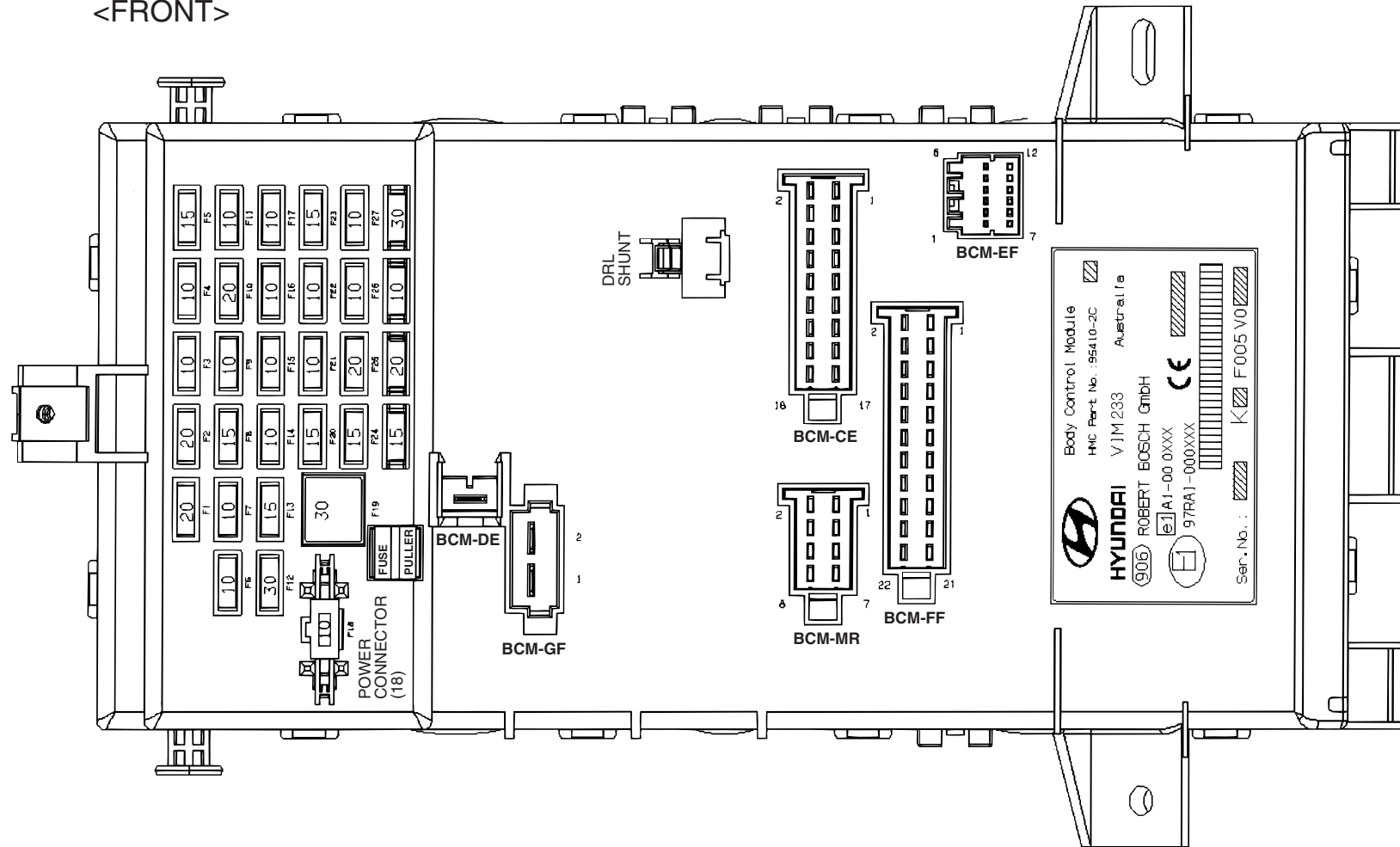

FUSE & RELAY INFORMATION

FUSE & RELAY INFORMATION (2)

SD100-2

CIRCUIT	NO.	FUSE	Amperages(A)	Circuit Protected
FUSE	1	IG COIL	20A	Ignition coil (G4ED/G6BA), Electro chromic mirror
	2	AMP	20A	AMP
	3	B/UP LAMP	10A	Back-up lamp switch, Transaxle range switch, Cruise control module, Stop lamp switch
	4	A/BAG IND	10A	Instrument cluster (A/BAG IND.)
	5	A/BAG	15A	SRS control module
	6	HTD MIR	10A	Mirror defogger, A/C control module
	7	HAZARD	10A	Hazard relay
	8	R/WIPER	15A	Rear wiper motor, Rear intermittent wiper relay
	9	TAIL-RH	10A	Right tail lamps, Glove box lamp, Illuminations
	10	F/WIPER	20A	Front wiper motor, Front wiper relay
	11	A/C SW	10A	Not used
	12	RR DEFOG	30A	Defogger relay
	13	STOP	15A	Stop lamp switch, Burglar alarm horn relay, Folding/ Unfolding relay
	14	TAIL-LH	10A	Left tail lamps
	15	A/CON	10A	A/C control module, Blower relay, Clock & switch module
	16	ECU	10A	ECM, Multi gauge unit, TCM, Vehicle speed sensor, Pulse generator
	17	CLUSTER	10A	Instrument cluster (Power), Pre-excitation resistor, DRL Control module, Generator
	18	POWER CONNECTOR	10A	Room lamp, Audio, Data link connector, Multi gauge unit, Clock & switch module
	19	P/WINDOW	30A	Power window relay
	20	T/GATE	15A	Tail gate lid switch
	21	IGN	10A	AQS sensor, Head lamp relay, DRL Control module, Head lamp leveling actuator
	22	RR FOG	10A	Rear fog lamp
	23	C/LIGHT	15A	Cigarette lighter, Outside mirror switch
	24	S/ROOF	15A	Power door lock/ Unlock relay, Overhead console lamp & sunroof switch
	25	S/HTR	20A	Seat warmer switch
	26	ABS	10A	ESP/ABS control module
	27	AUDIO	10A	Audio, Clock & switch module

*** USE THE DESIGNATED FUSE ONLY**

BODY CONTROL MODULE (BCM BOX)

< FRONT >

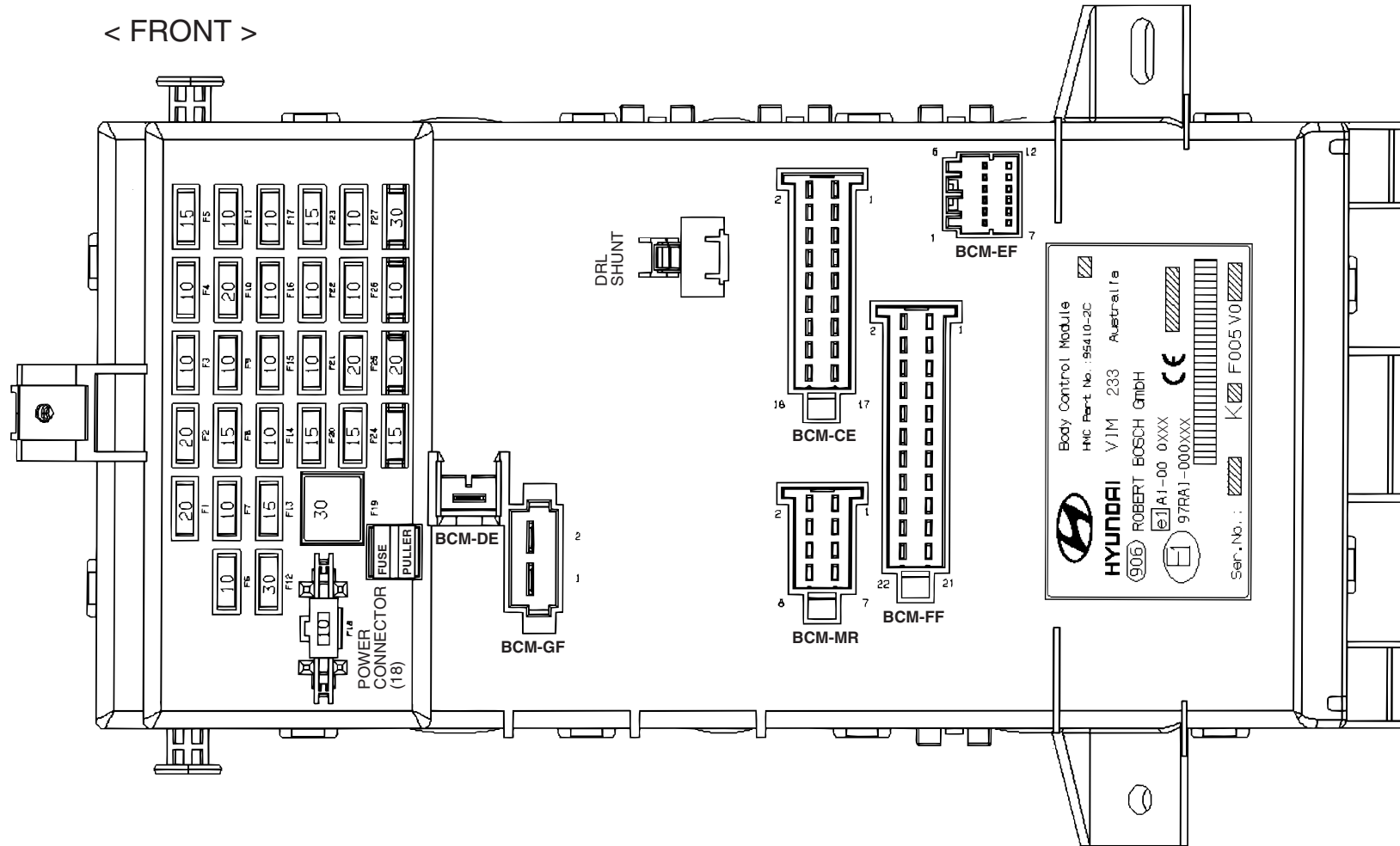

FUSE & RELAY INFORMATION

FUSE & RELAY INFORMATION (4)

SD100-4

CIRCUIT

CONNECTOR NAME	PIN NO.	DESCRIPTION	CONNECTOR NAME	PIN NO.	DESCRIPTION
BCM-CE	1	H/LP LOW RLY S2	BCM-FF	1	REAR FOG LAMP RLY
	2	RHEOSTAT		2	BACK UP LP
	3	FR WIPER RLY CONTROL		3	NC
	4	FRONT FOG RELAY		4	O/S MIRR
	5	T/SIG FR		5	TAIL LP RH
	6	DRL (TS)		6	DOOR LOCK FEED
	7	TAIL RLY (S2)		7	NC
	8	FR WIPER RELAY - IG2		8	DOOR UNLOCK FEED
	9	T/SIG FL		9	NC
	10	POSITION LP RH		10	TAIL LP LH
	11	POSITION LP LH		11	4 DOOR SW
	12	ABS, ESP (IG1)		12	MIRROR UNFOLD
	13	ALT 'L'.		13	T/SIG RL
	14	IG2		14	NC
	15	WIPER PARK OUTPUT		15	LUGGAGE LP
	16	WASHER MOTOR		16	NC
	17	NC		17	T/SIG RR
	18	NC		18	AMP
BCM-DE	1	B+ 50A		19	O/S MIRR HTR
BCM-EF	1	NC		20	MIRROR FOLD
	2	T/GATE LOCK SW		21	R/WIPER MTR - IG2
	3	ASS DR LOCK SW		22	TAIL GATE OPEN SW
	4	ASS DR SW	BCM-GF	1	RR HTD
	5	FOLDING SW	2	P/WDW SW	
	6	NC	BCM-MR	1	S/ROOF - IG2
	7	DRV DR KEY SW		2	ROOM LP B+
	8	DRIVE DR LOCK SW		3	ROOF LP DECAY CONTROL
	9	DRIVE DR SW		4	ECM(IG1)
	10	S/BELT SW		5	NC
	11	NC		6	S/ROOF & ROOM LP GROUND
	12	NC		7	ECM - MIRROR
		8		S/ROOF (MTR) (B+)	

BODY CONTROL MODULE (BCM BOX)

< REAR >

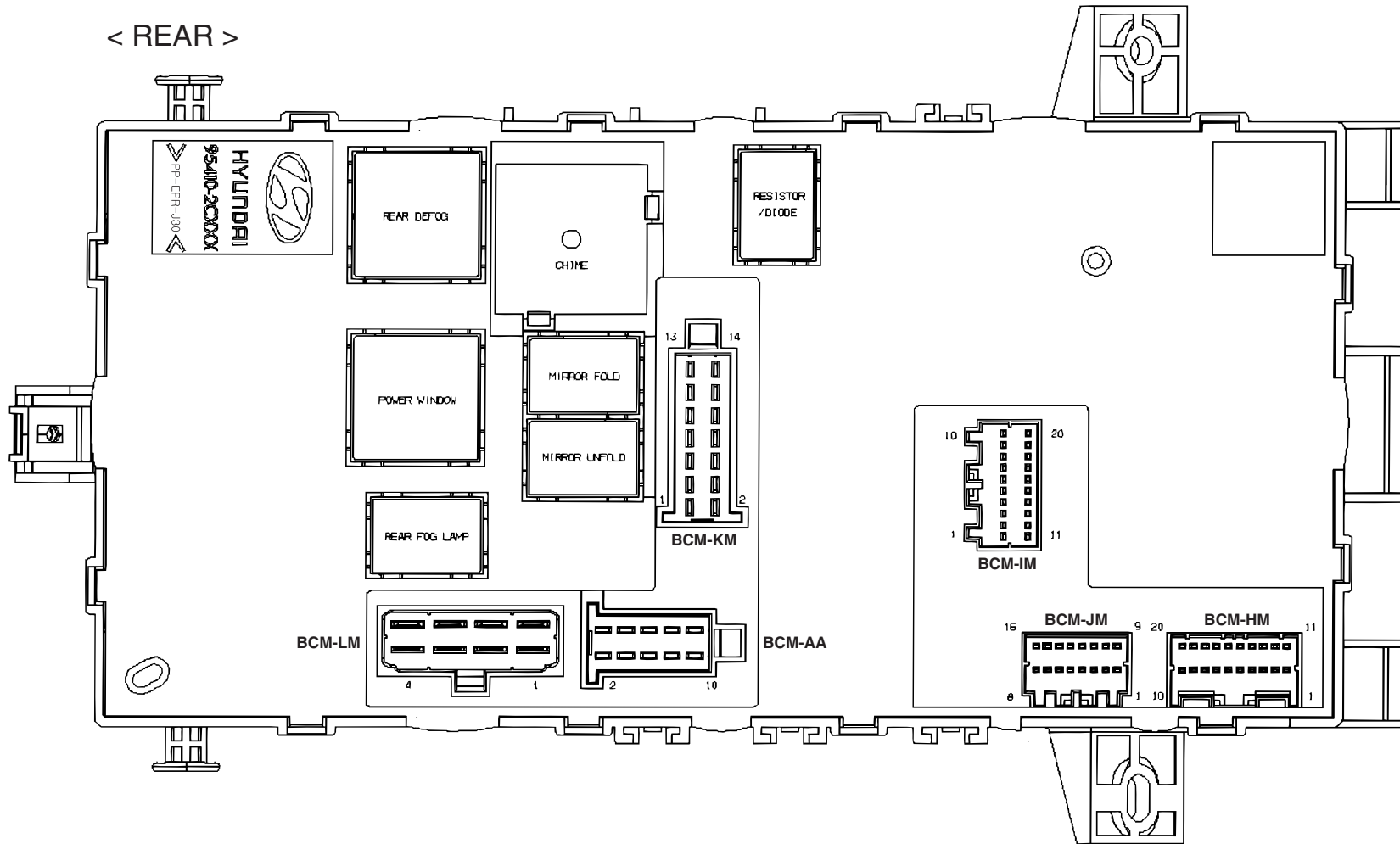

FUSE & RELAY INFORMATION

FUSE & RELAY INFORMATION (6)

SD100-6

CIRCUIT

CONNECTOR NAME	PIN NO.	DESCRIPTION	CONNECTOR NAME	PIN NO.	DESCRIPTION	
BCM-AA	1	NC	BCM-IM	15	EXT TAIL LAMP RH	
	2	NC		16	MUT(A/BAG K-LINE)	
	3	NC		17	A/CON MODULE-IG2	
	4	ESPS(IG1)		18	A/LIGHT SNSR GND	
	5	NC		19	DIAGNOSIS	
	6	NC		20	IMMO W-LINE	
	7	CRASH SIG		BCM-JM	1	M/F INT T GND
	8	NC			2	SIREN CONTROL
	9	A/BAG(K-LINE)			3	KEY HOLE ILL.
	10	A/BAG WARN'G LAMP			4	SPEED SIG
BCM-HM	1	IMMO ANTENNA 1	5		ILL +	
	2	NC	6		CLUSTER(A/BAG WARN'G IND)	
	3	T/SIG RIGHT SW	7		DCT	
	4	DR WARN'G SW	8		DOOR AJAR	
	5	TAIL LP SW	9		FRT WIPER INT SW	
	6	RR FOG SW	10		FRT WIPER INT T	
	7	CODE SAVE	11	A/LIGHT SIG		
	8	NC	12	SEAT BELT INDICATOR		
	9	HOOD SW	13	NC		
	10	NC	14	NC		
	11	IMMO ANTENNA 2	15	A/LIGHT SUPPLY		
	12	EXPORT GROUND	16	T/GATE OPEN IND		
	13	T/SIG LEFT SW	BCM-KM	1	CIGAR LIGHTER ACC	
	14	AUTO LIGHT SW		2	WIPER LOW	
	15	NC		3	WIPER HIGH	
	16	H/LP SW		4	BACK-UP SW	
	17	FR FOG SW		5	AUDIO - ACC	
	18	HAZARD SW		6	WIPER WASHER MTR SW	
	19	RR HTD SW		7	BACK UP LP SW	
	20	REAR FOG LAMP IND.		8	START RELAY	
BCM-IM	1	NC		9	S/HTR SW - IG2	
	2	CLUSTER BATT CHARGE		10	ROOM LP	
	3	NC	11	STOP SW - B+		
	4	ESP SW IG1	12	IGN COIL		
	5	CLUSTER IG1	13	NC		
	6	CLUSTER IG1	14	FRT WIPER PARK OUTPUT		
	7	CLUSTER(T/SIG LP LH IND)	BCM-LM	1	A/LIGHT GND	
	8	ECU-IG1		2	NC	
	9	CLUSTER(T/SIG LP RH IND)		3	NC	
	10	RR HTD SW(FOR INDICATOR)		4	IGN SW(IG1)	
	11	CLUSTER(A/BAG IND)-IG1		5	GND2	
	12	MUT-B+		6	WIPER SW POWER	
	13	D/CLOCK-ACC		7	IGN SW(ACC)	
	14	IMMOBILIZER IND.		8	IGN SW(IG2)	

FUSE & RELAY INFORMATION

FUSE & RELAY INFORMATION (7)

SD100-7

E/R BOX

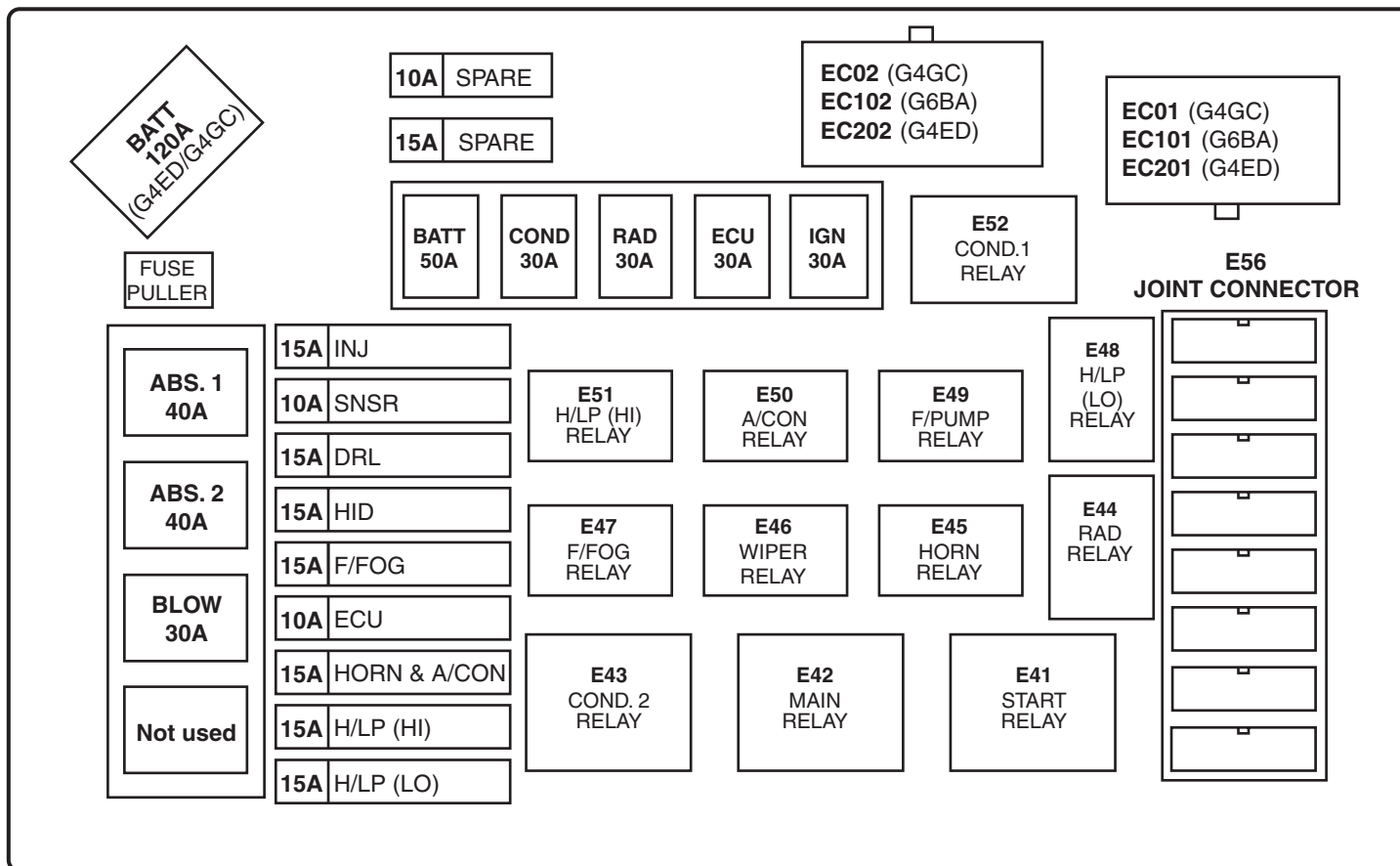

*** USE THE DESIGNATED FUSE ONLY**

FUSE & RELAY INFORMATION

FUSE & RELAY INFORMATION (8)

SD100-8

CIRCUIT

	NO.	Amperages(A)	Circuit Protected
FUSIBLE LINK	BATT	120A	Generator (G4ED/G4GC)
	BATT	50A	BCM BOX (Tail lamp relay, Power connector, Defogger relay)
	COND	30A	COND.1 (Condenser fan) relay
	RAD	30A	RAD (Radiator fan) relay
	ECU	30A	Main relay, F/PUMP relay , A/T control relay, Generator, ECM (G4ED/G6BA), PCM (G4GC)
	IGN	30A	Ignition switch, Start relay
	ABS. 1	40A	ABS/ESP control module, ESP Air bleeding connector
	ABS. 2	40A	ABS/ESP control module, ESP Air bleeding connector
	BLOWER	30A	Blower relay
FUSE	INJ	15A	Injector
	SNSR	10A	Oxygen sensor, Camshaft position sensor, Crankshaft position sensor, Idle speed control actuator
	DRL	15A	DRL control module
	HID	15A	-
	F/FOG	15A	F/FOG relay
	ECU	10A	TCM (G6BA), ECM (G6BA/G4ED)
	HORN & A/CON	15A	A/CON relay, Horn relay
	H/LP (HI)	15A	H/LP (Hi) relay
	H/LP (LO)	15A	H/LP (Lo) relay

POWER DISTRIBUTION (1)

SD110-1

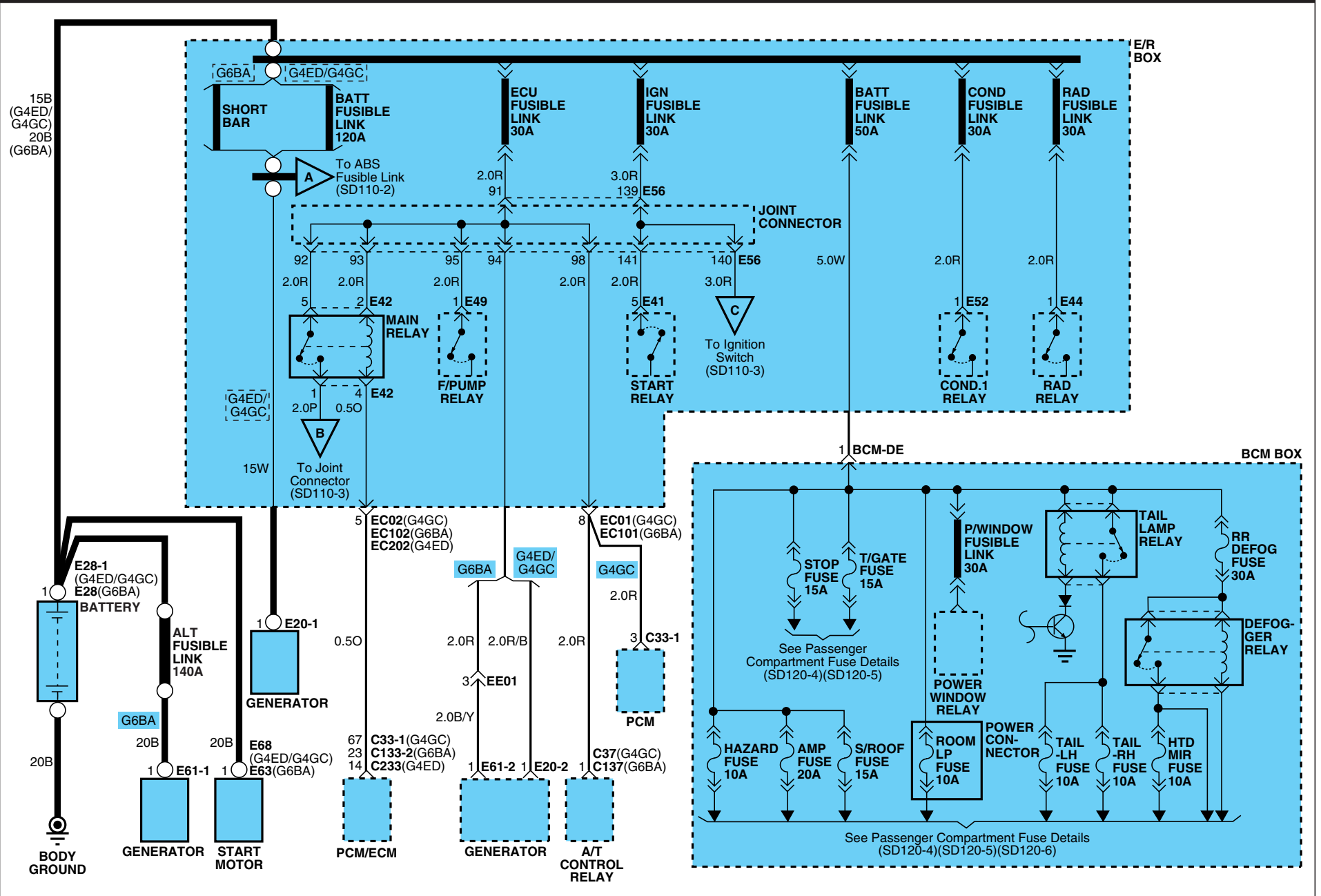

POWER DISTRIBUTION

POWER DISTRIBUTION (2)

SD110-2

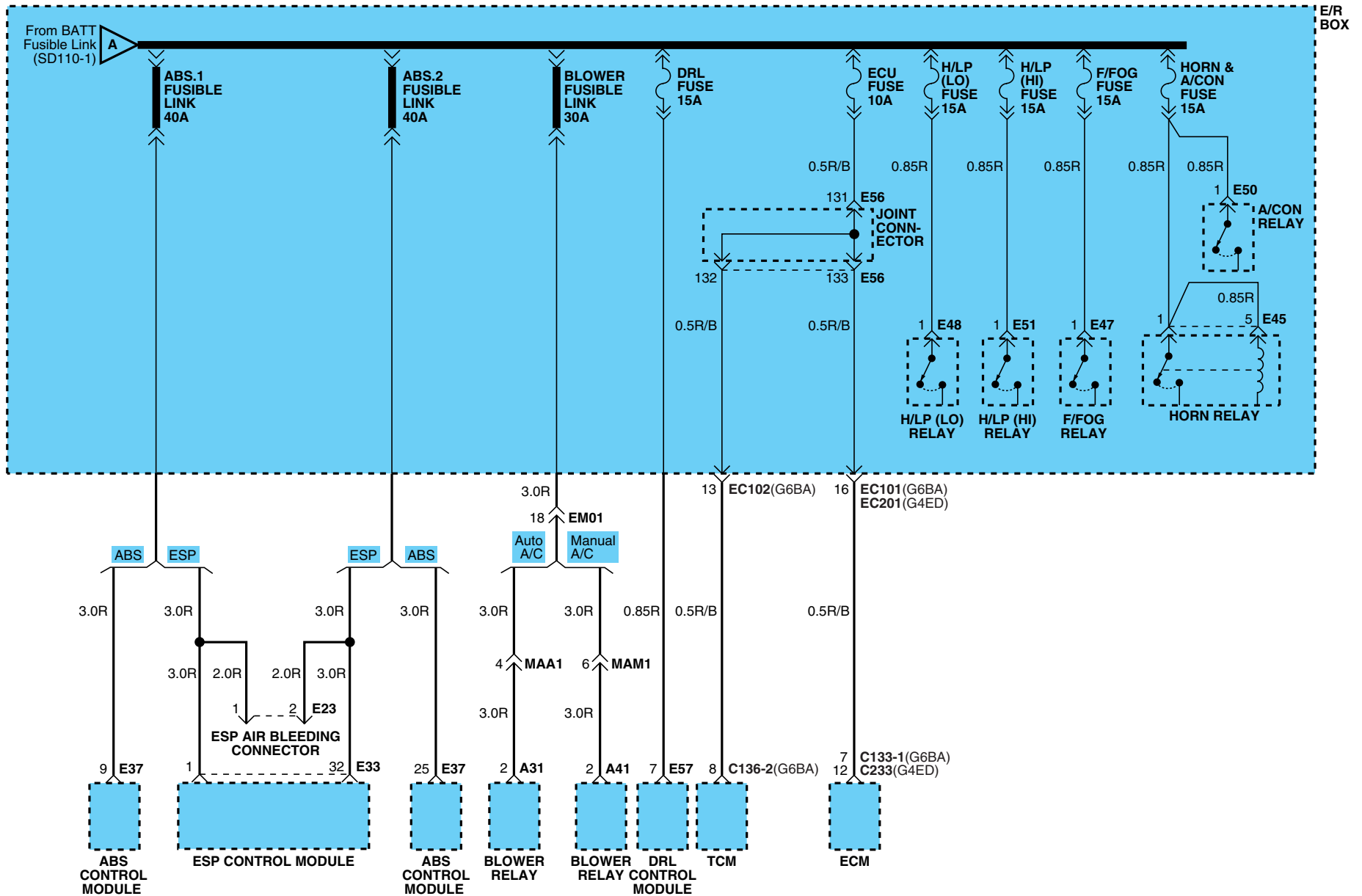

POWER DISTRIBUTION

POWER DISTRIBUTION (3)

SD110-3

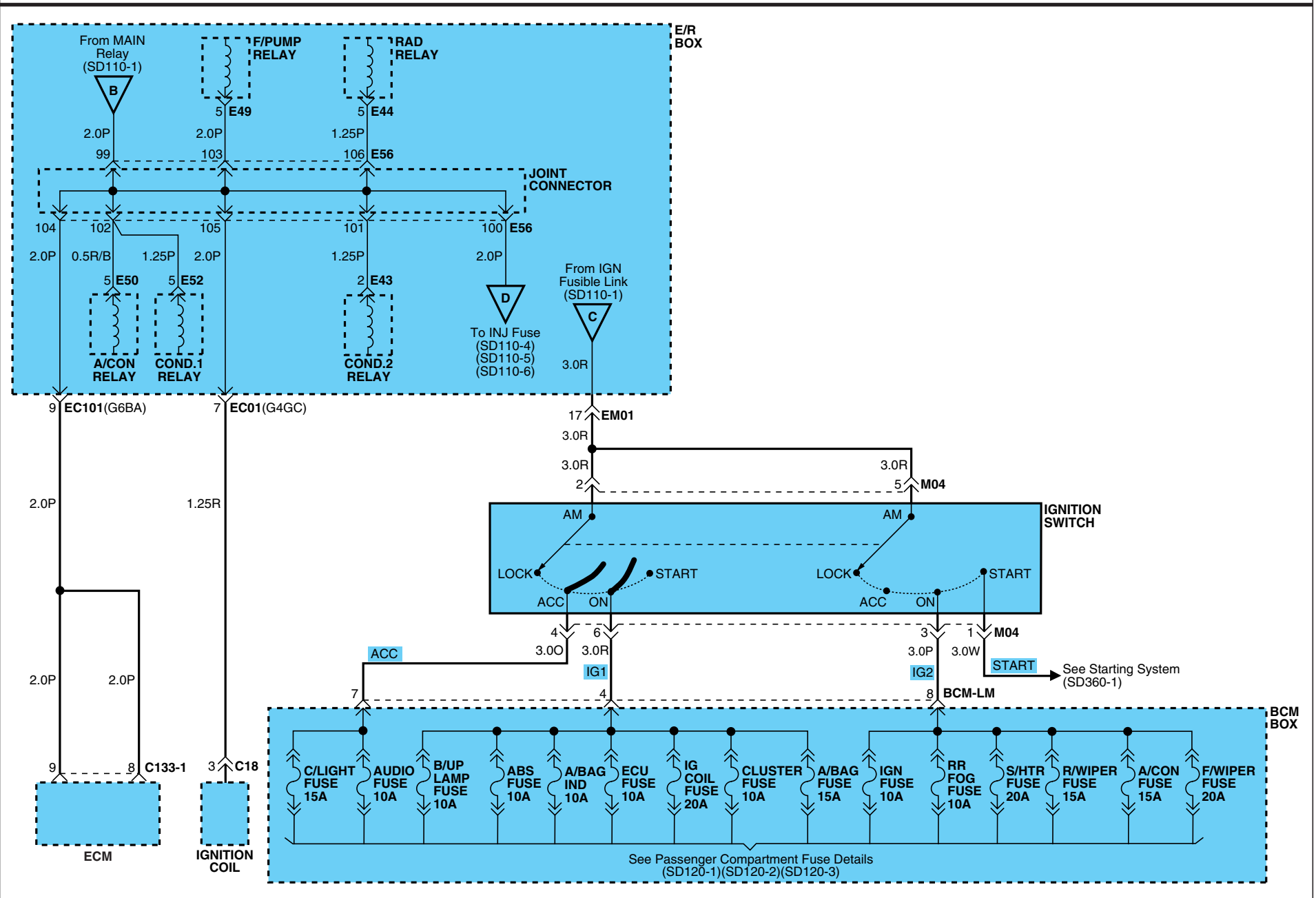

POWER DISTRIBUTION

POWER DISTRIBUTION (4)

SD110-4

G4GC

E/R BOX

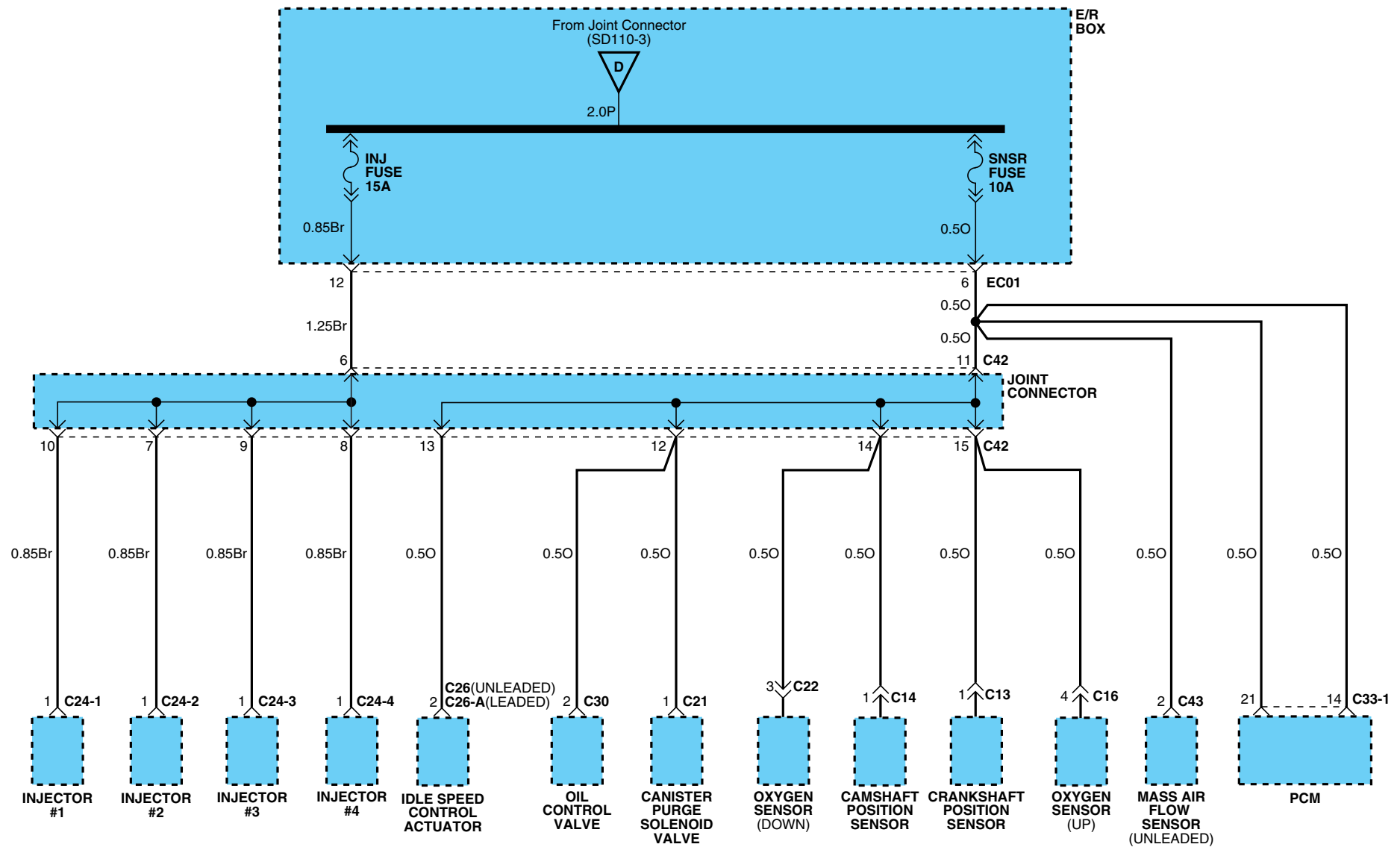

POWER DISTRIBUTION

POWER DISTRIBUTION (5)

SD110-5

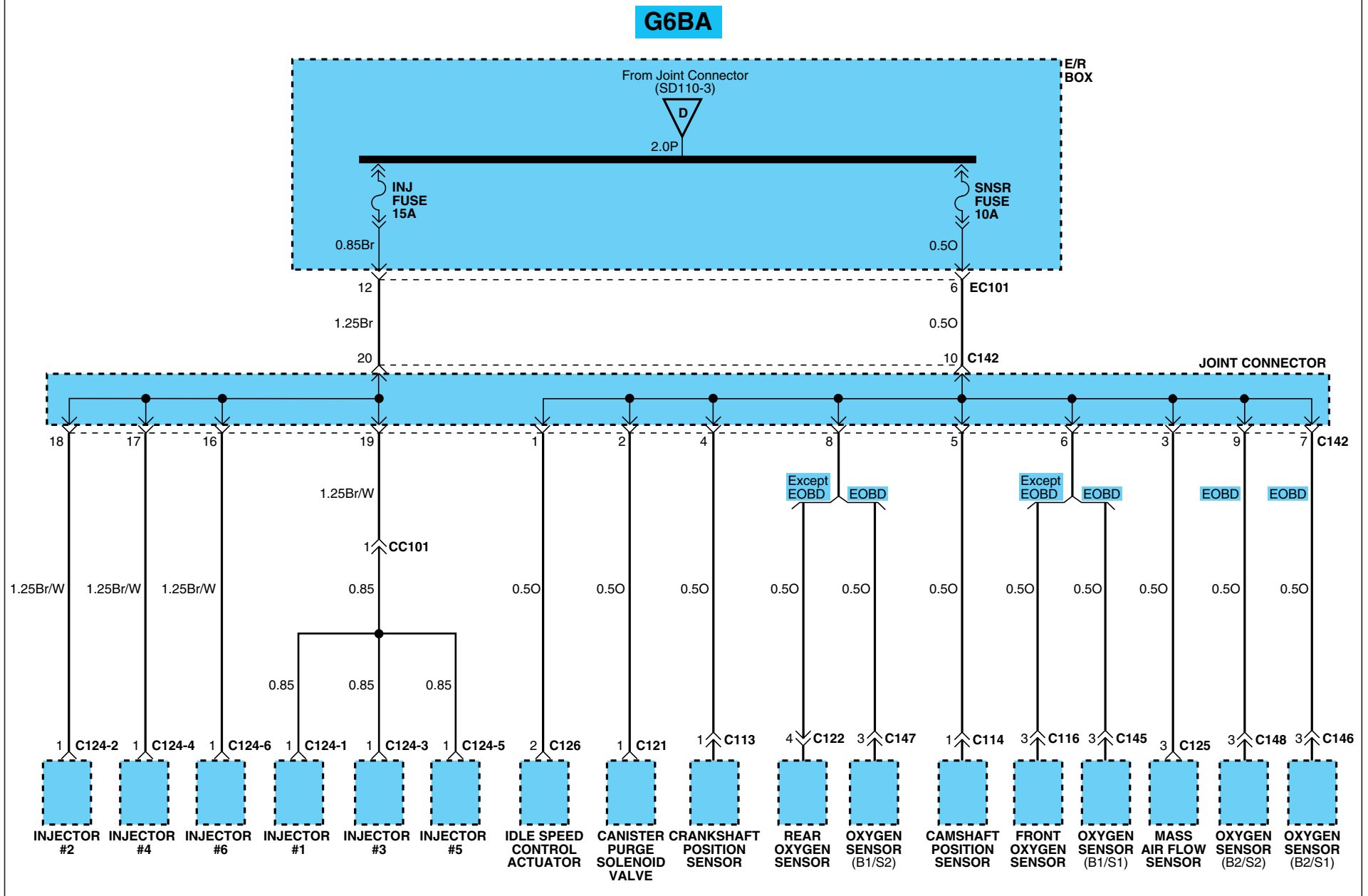

POWER DISTRIBUTION

POWER DISTRIBUTION (6)

SD110-6

G4ED

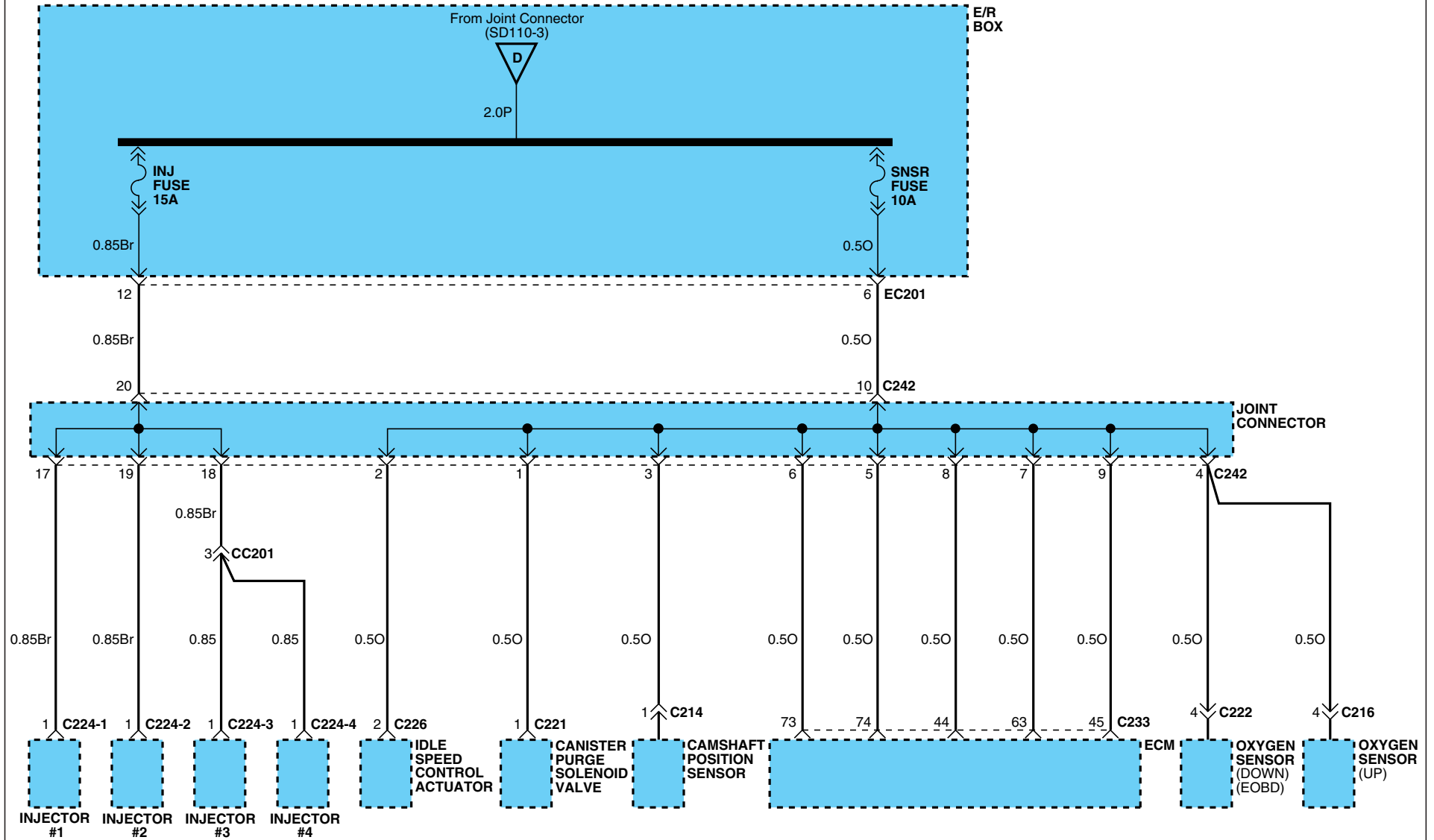

PASSENGER COMPARTMENT FUSE DETAILS (1)

SD120-1

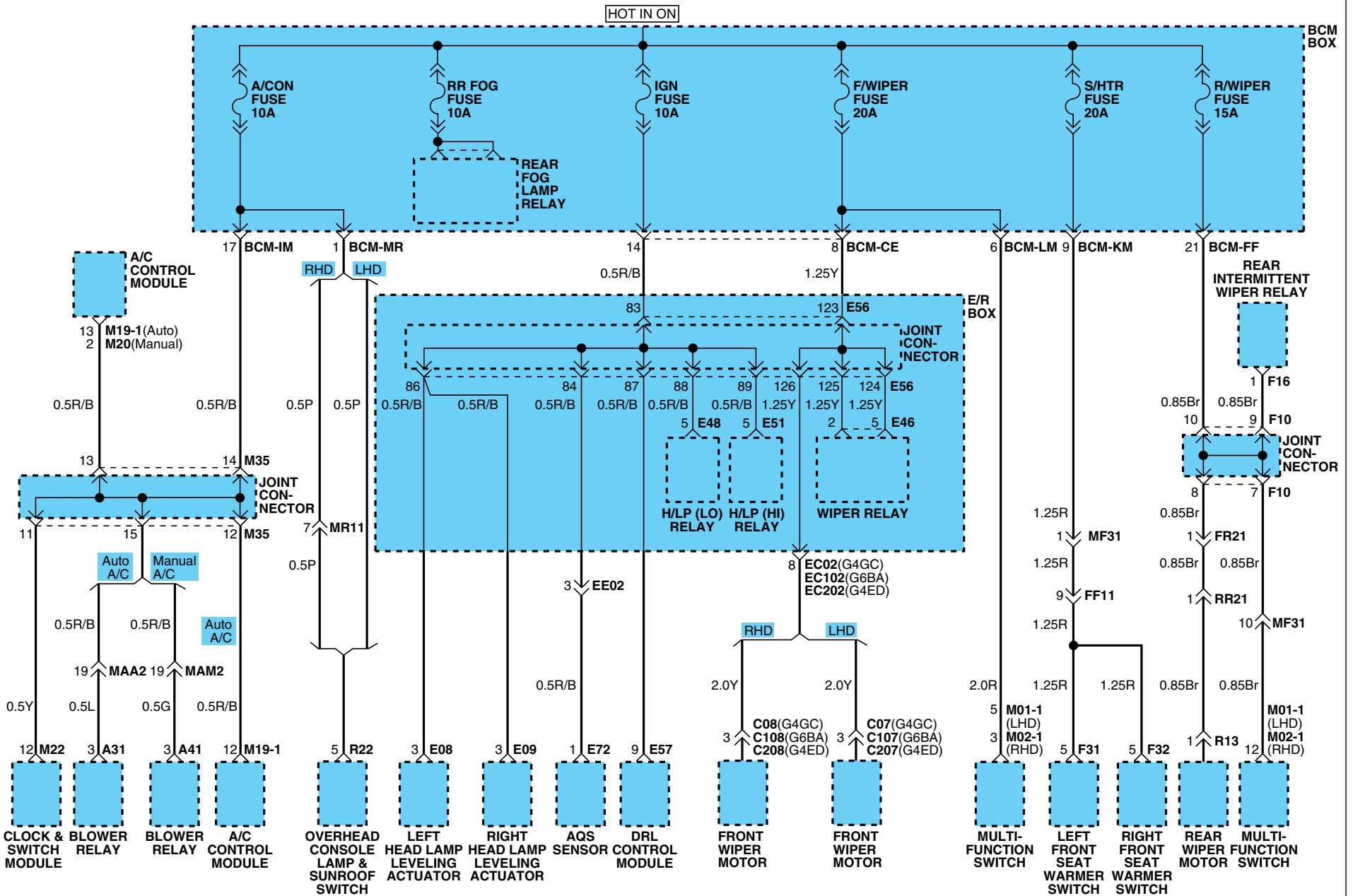

PASSENGER COMPARTMENT FUSE DETAILS

PASSENGER COMPARTMENT FUSE DETAILS (2)

SD120-2

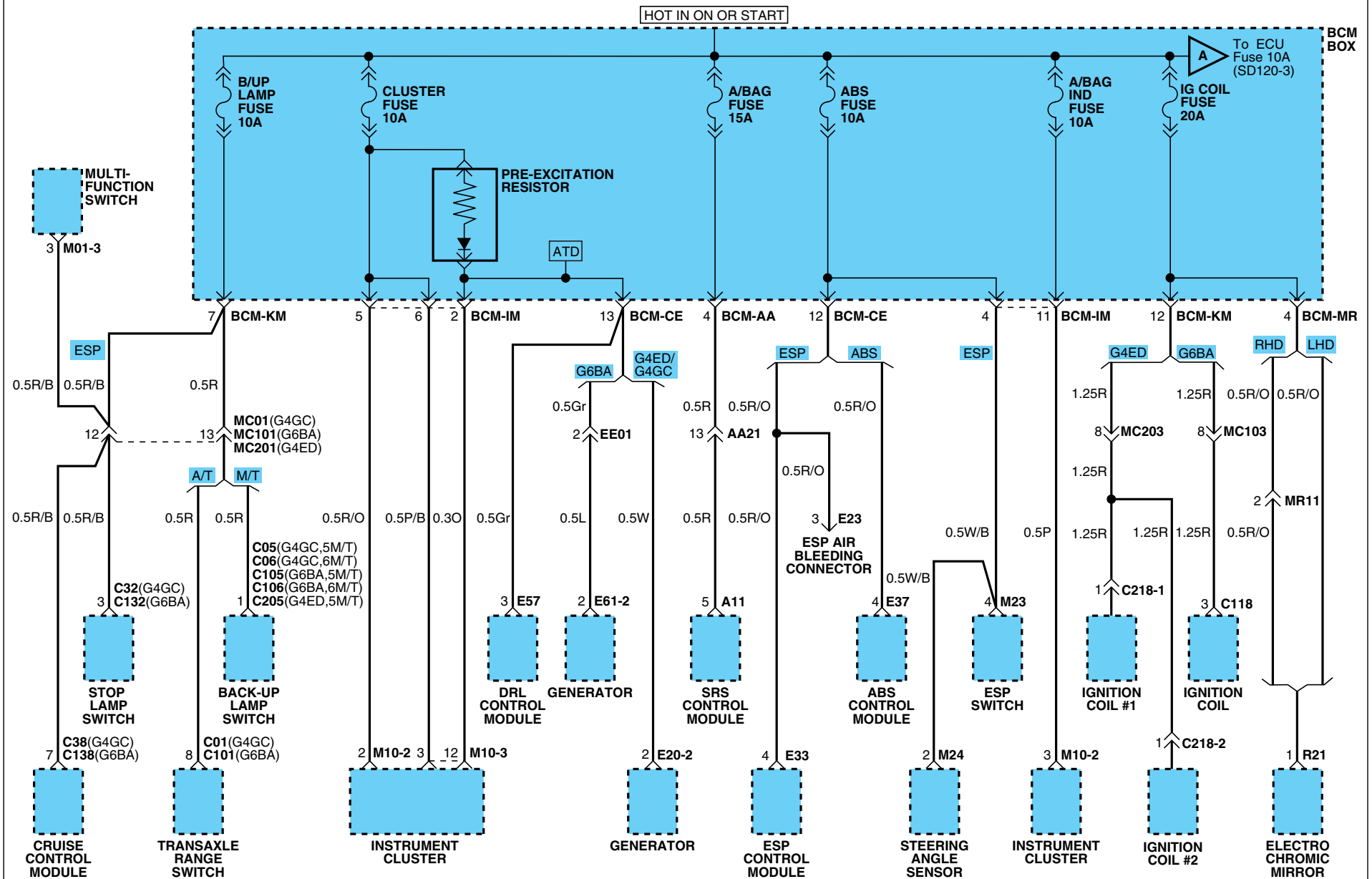

PASSENGER COMPARTMENT FUSE DETAILS

PASSENGER COMPARTMENT FUSE DETAILS (3)

SD120-3

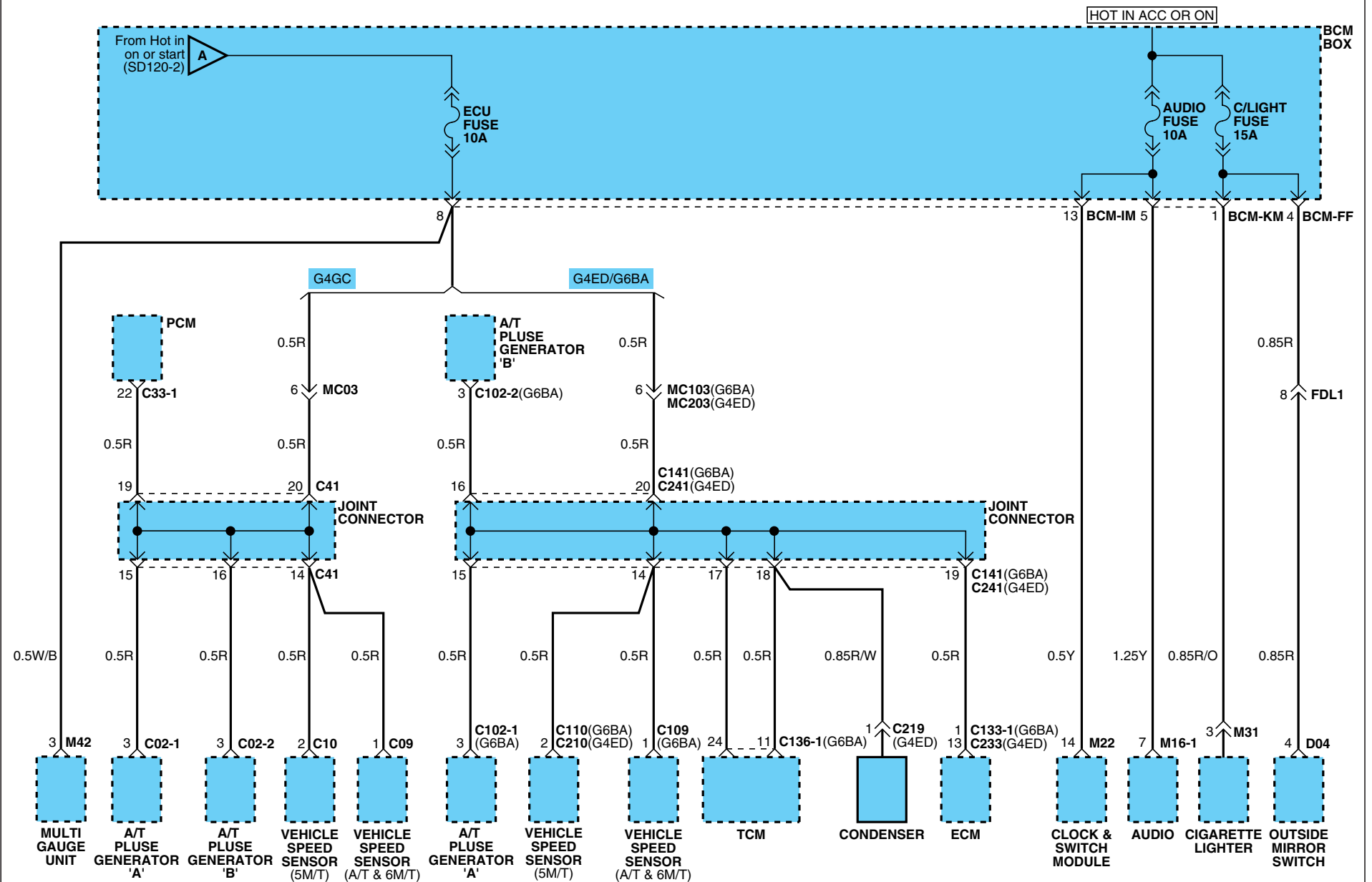

PASSENGER COMPARTMENT FUSE DETAILS

PASSENGER COMPARTMENT FUSE DETAILS (5)

SD120-5

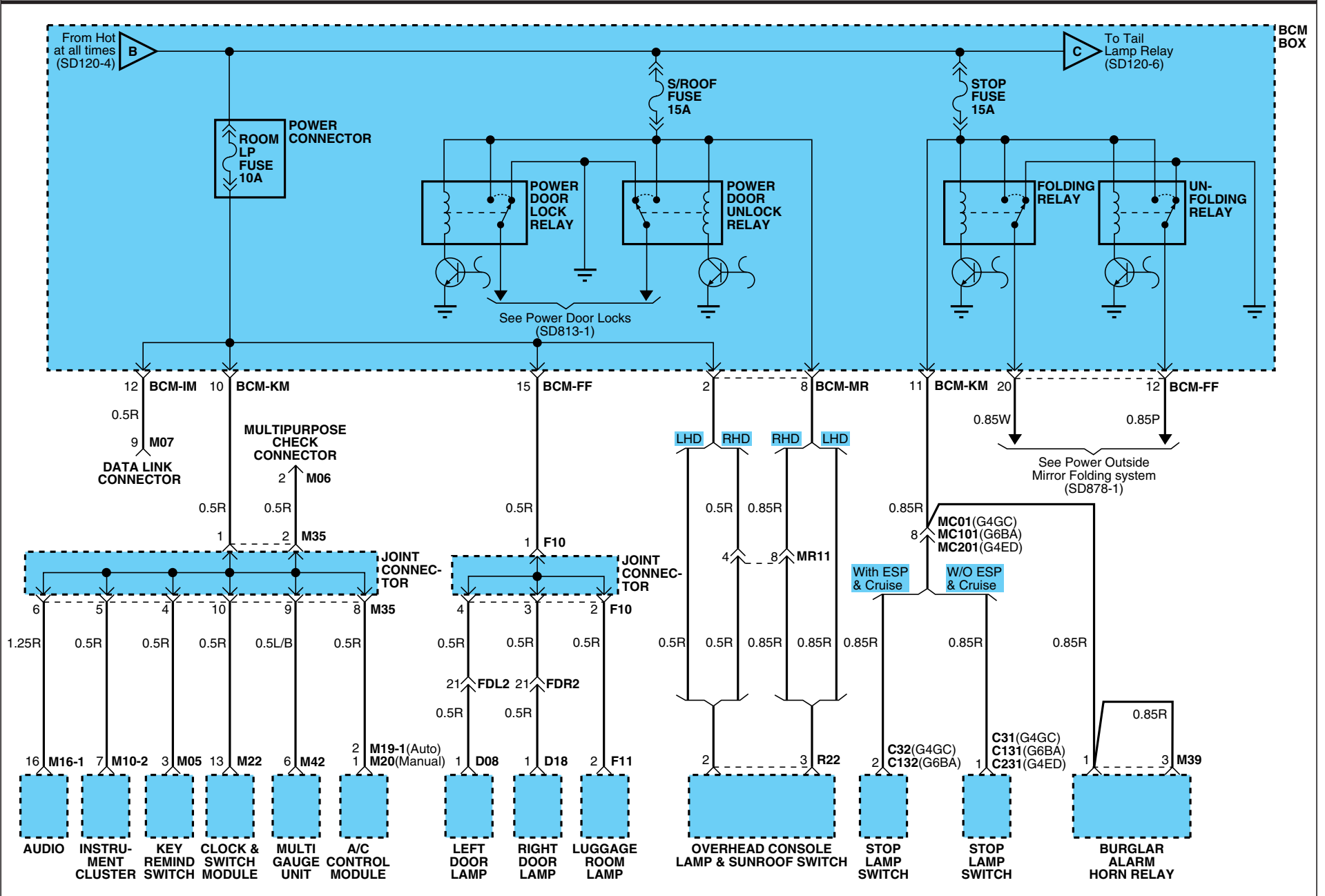

PASSENGER COMPARTMENT FUSE DETAILS

PASSENGER COMPARTMENT FUSE DETAILS (6)

SD120-6

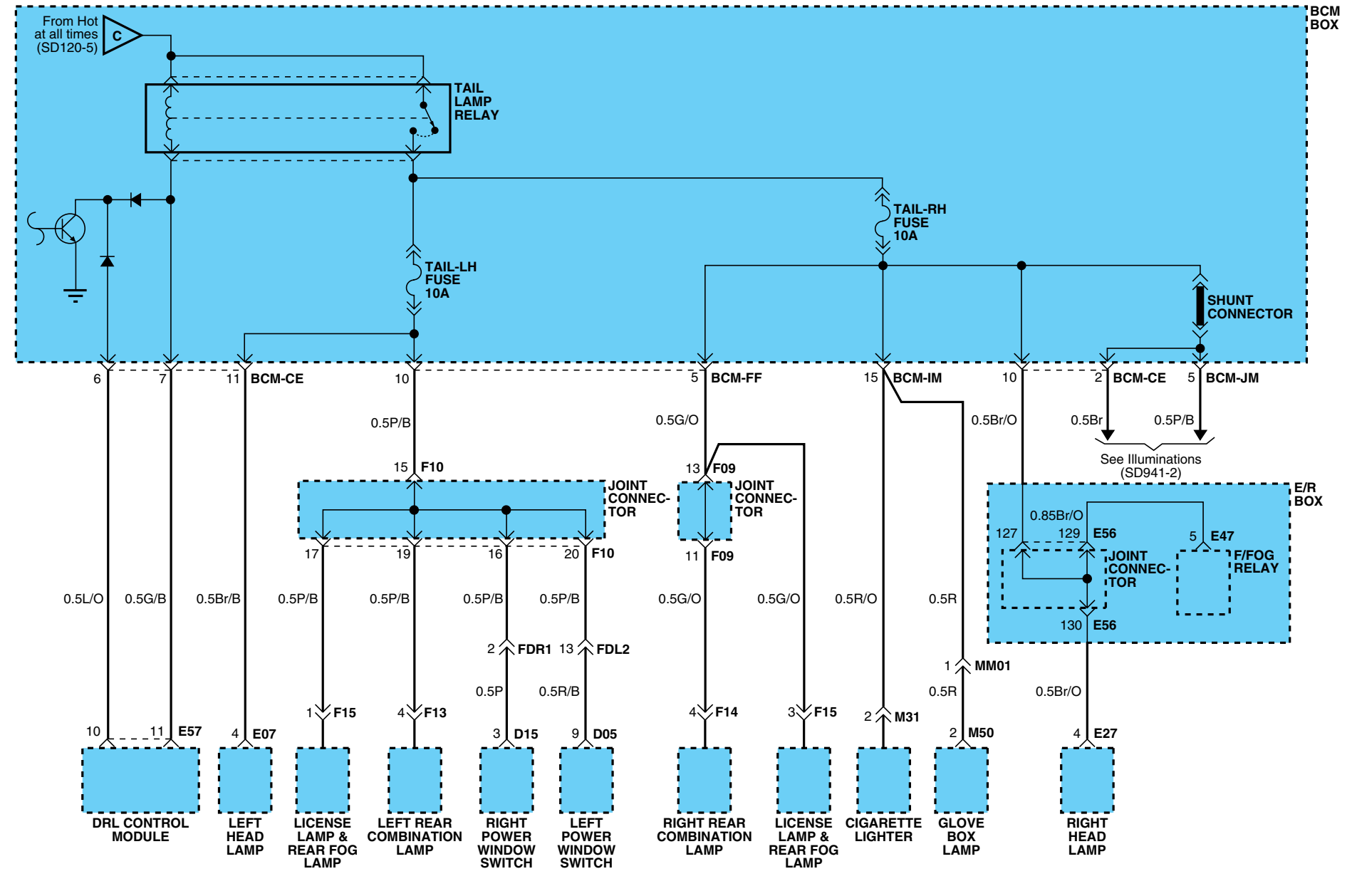

GROUND DISTRIBUTION (1)

SD130-1

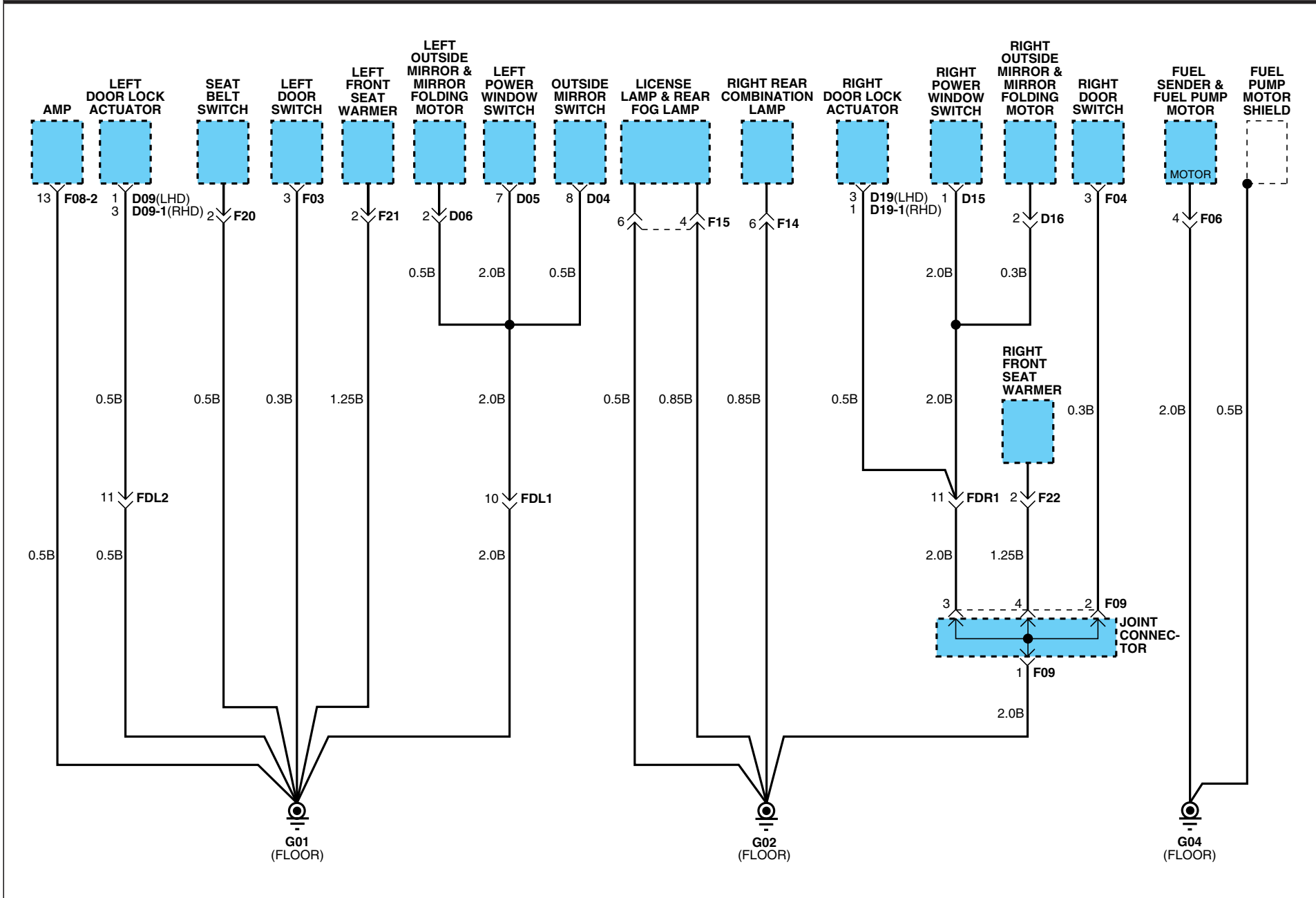

GROUND DISTRIBUTION

GROUND DISTRIBUTION (2)

SD130-2

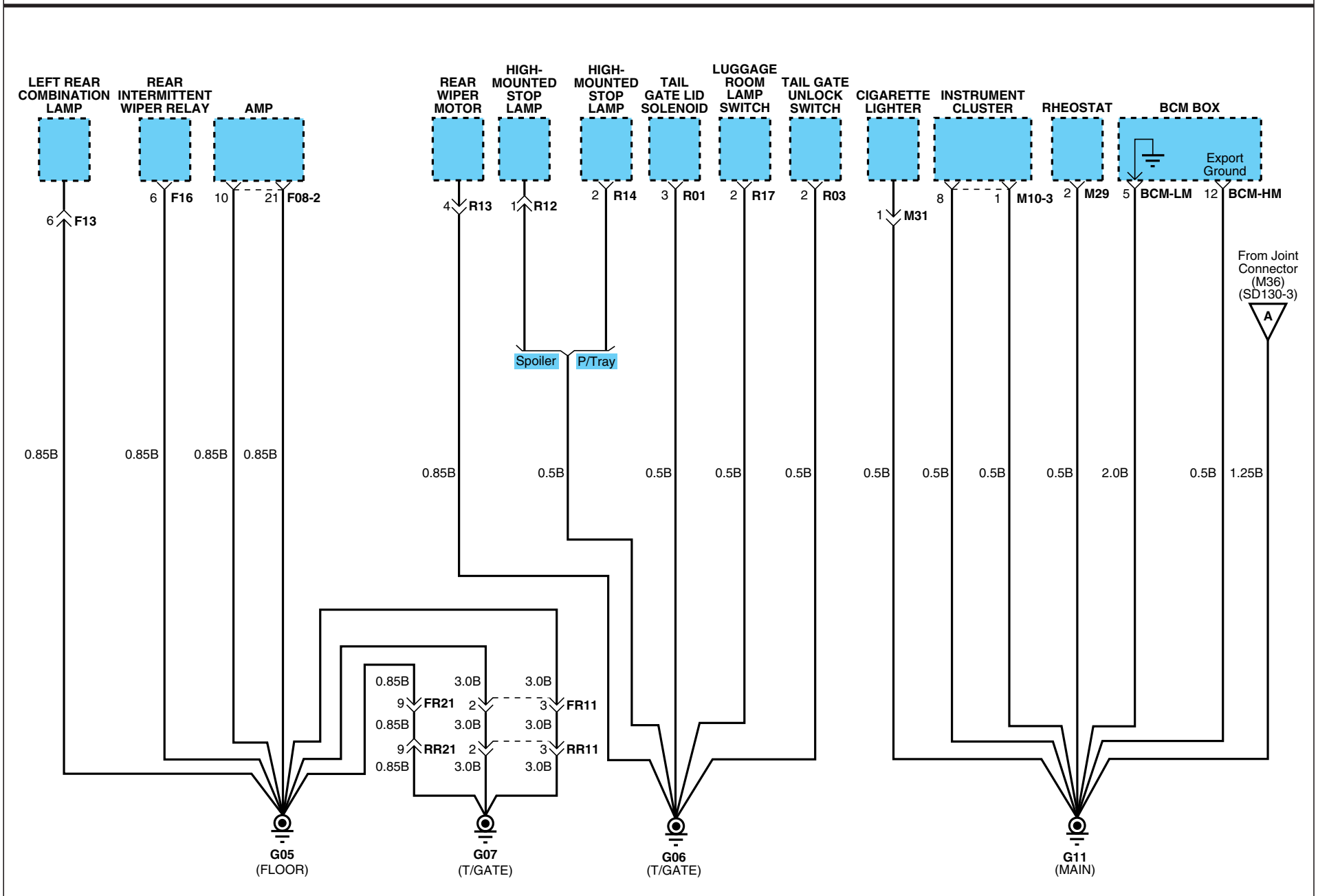

GROUND DISTRIBUTION

GROUND DISTRIBUTION (3)

SD130-3

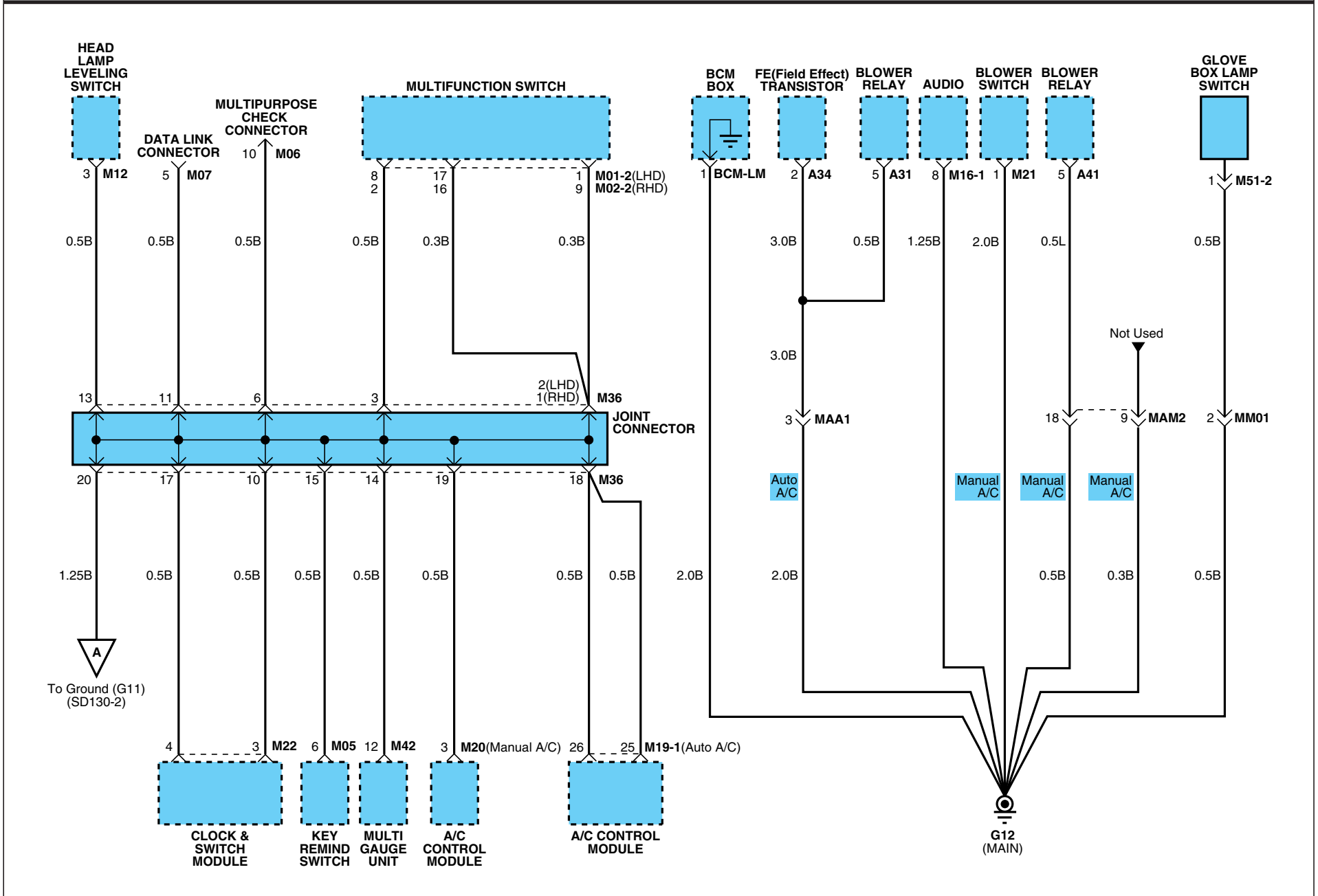

GROUND DISTRIBUTION

GROUND DISTRIBUTION (4)

SD130-4

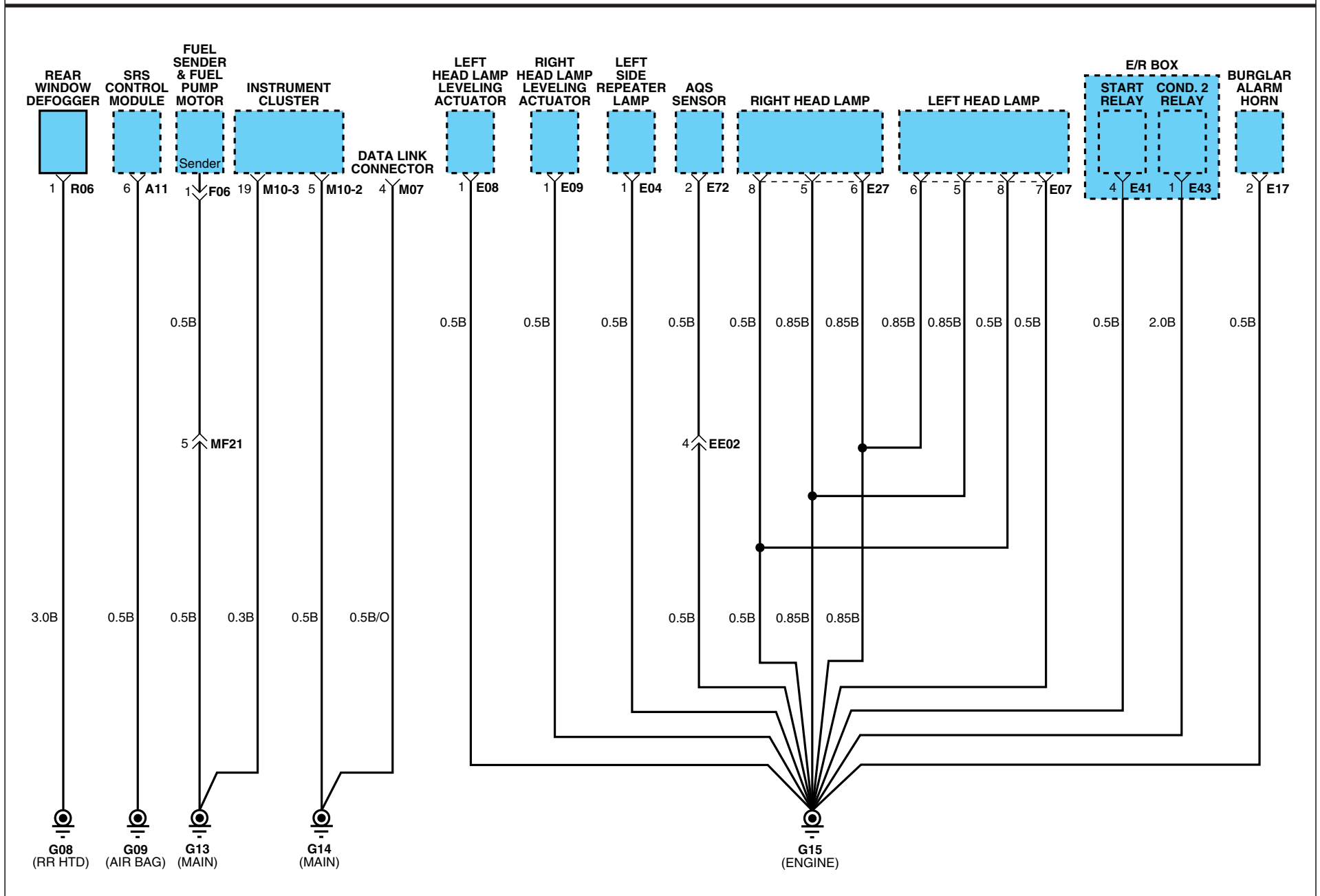

GROUND DISTRIBUTION

GROUND DISTRIBUTION (5)

SD130-5

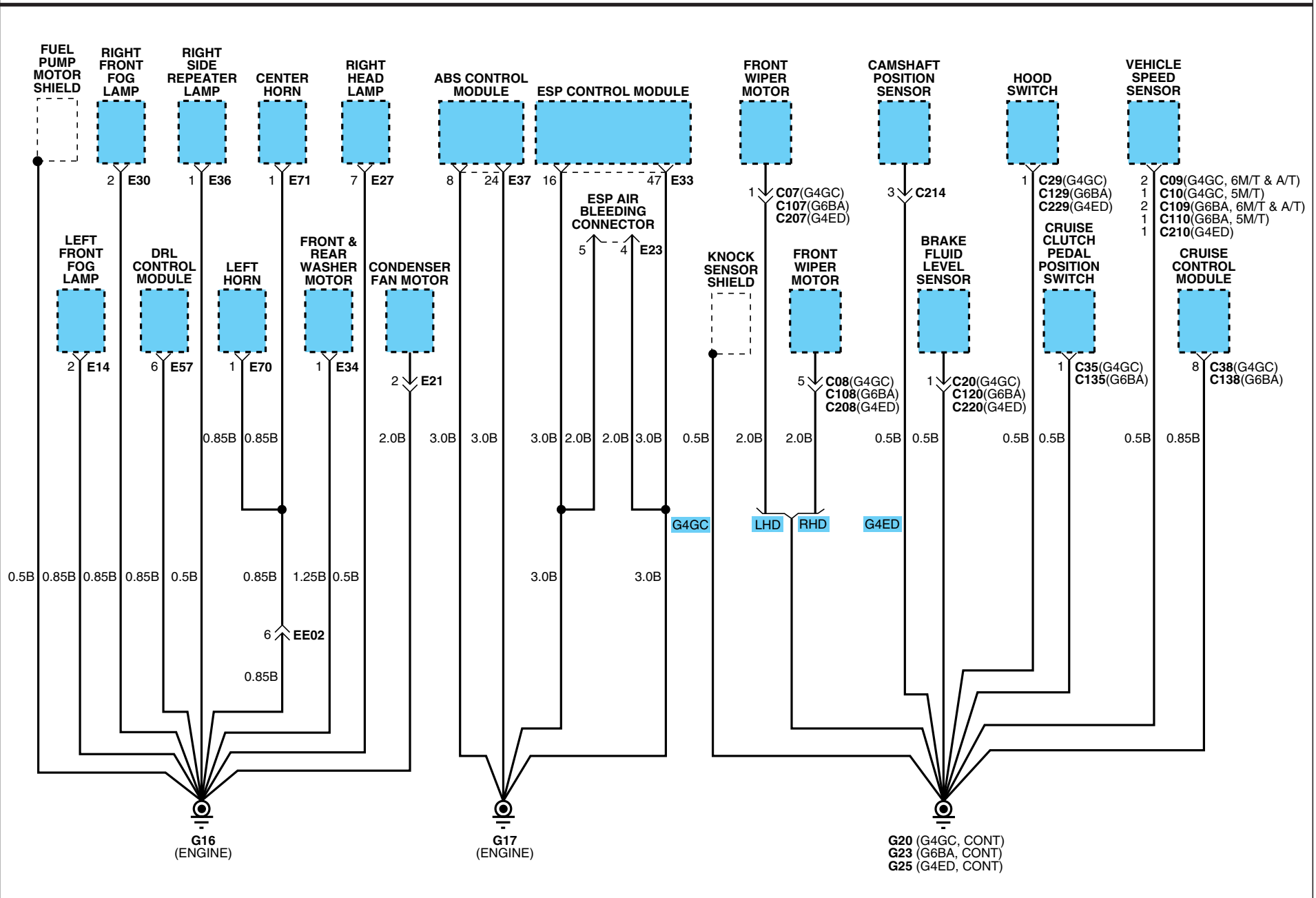

GROUND DISTRIBUTION

GROUND DISTRIBUTION (6)

SD130-6

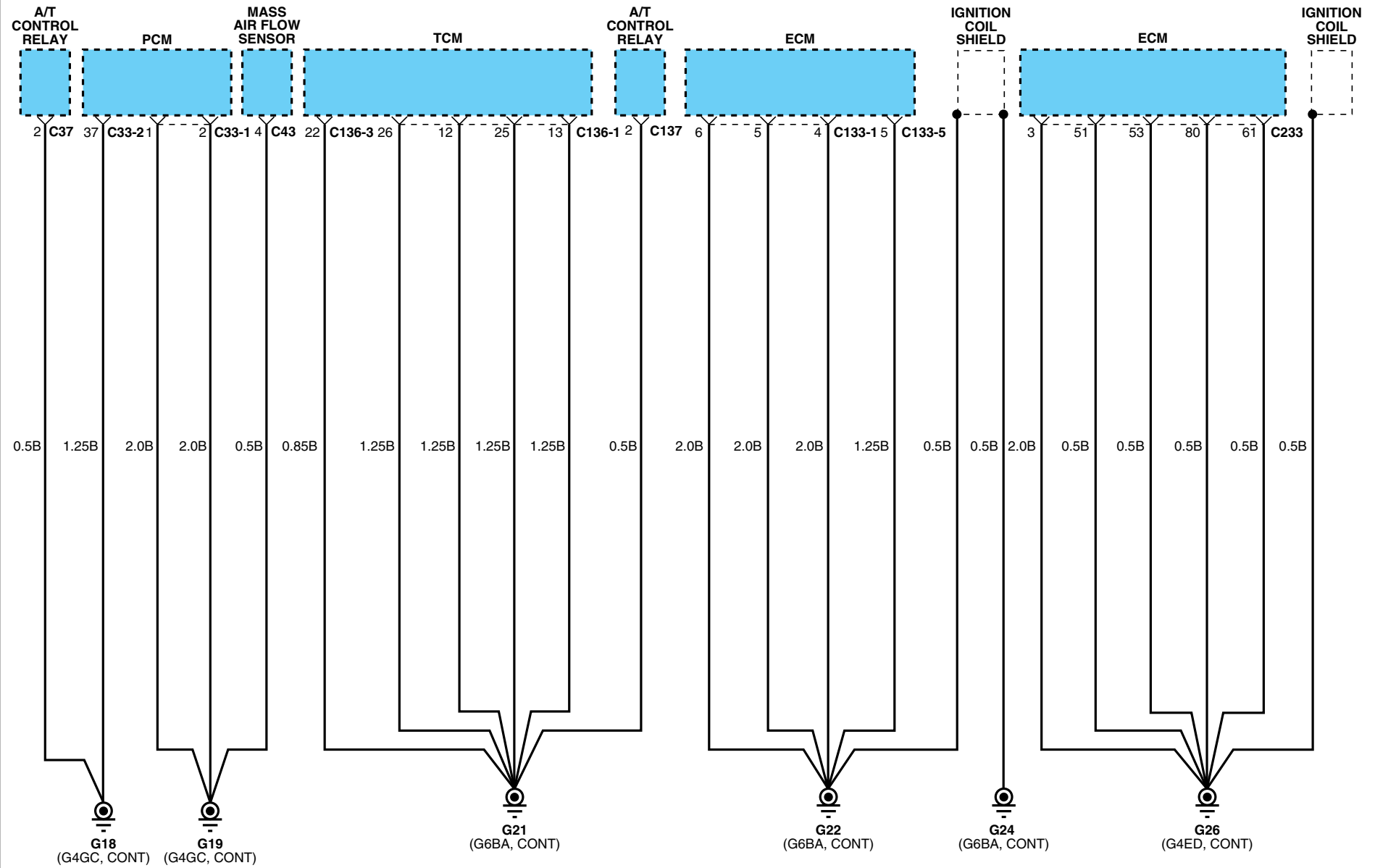

DATA LINK DETAILS (1)

SD200-1

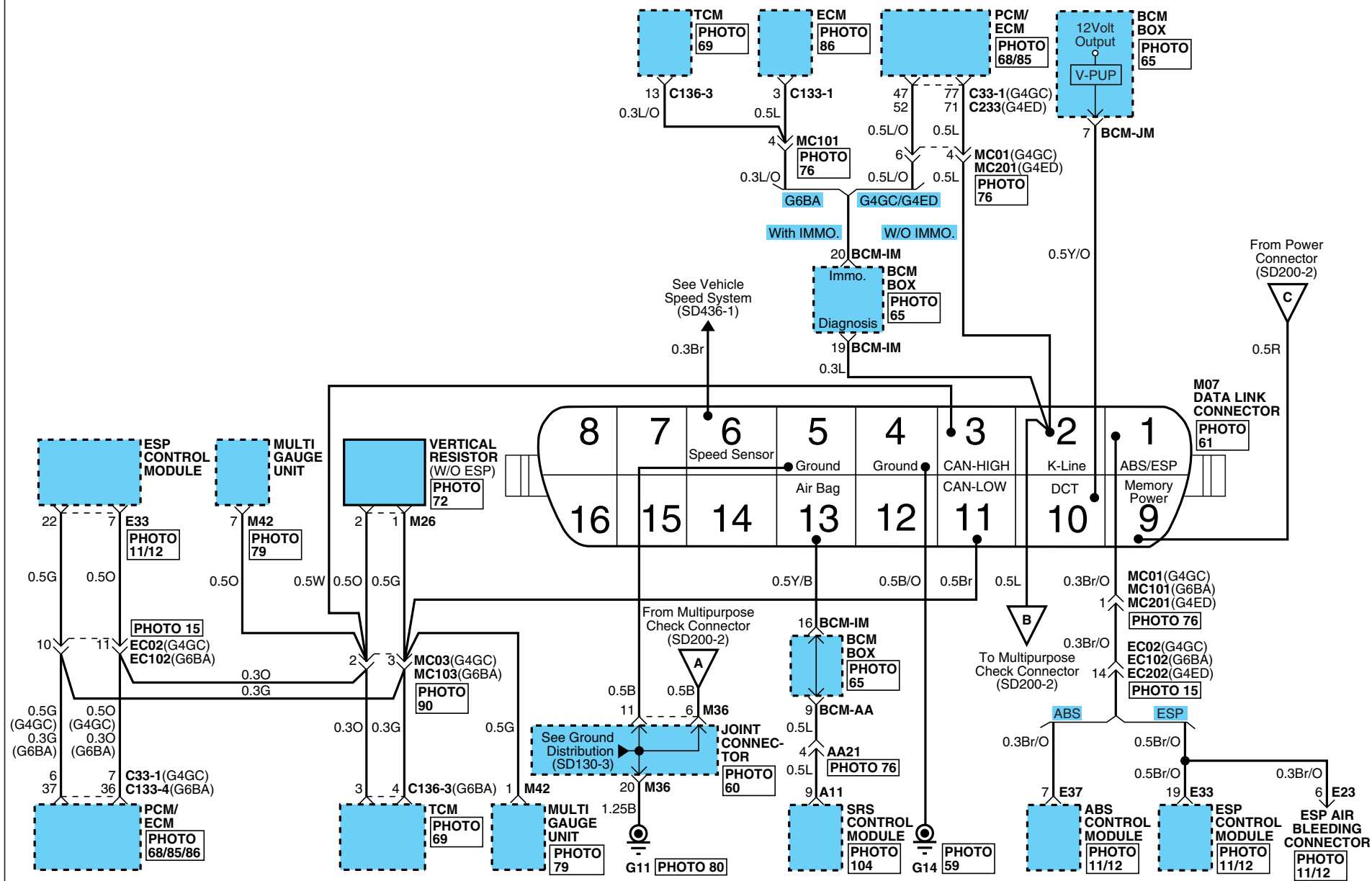

DATA LINK DETAILS

DATA LINK DETAILS (2)

SD200-2

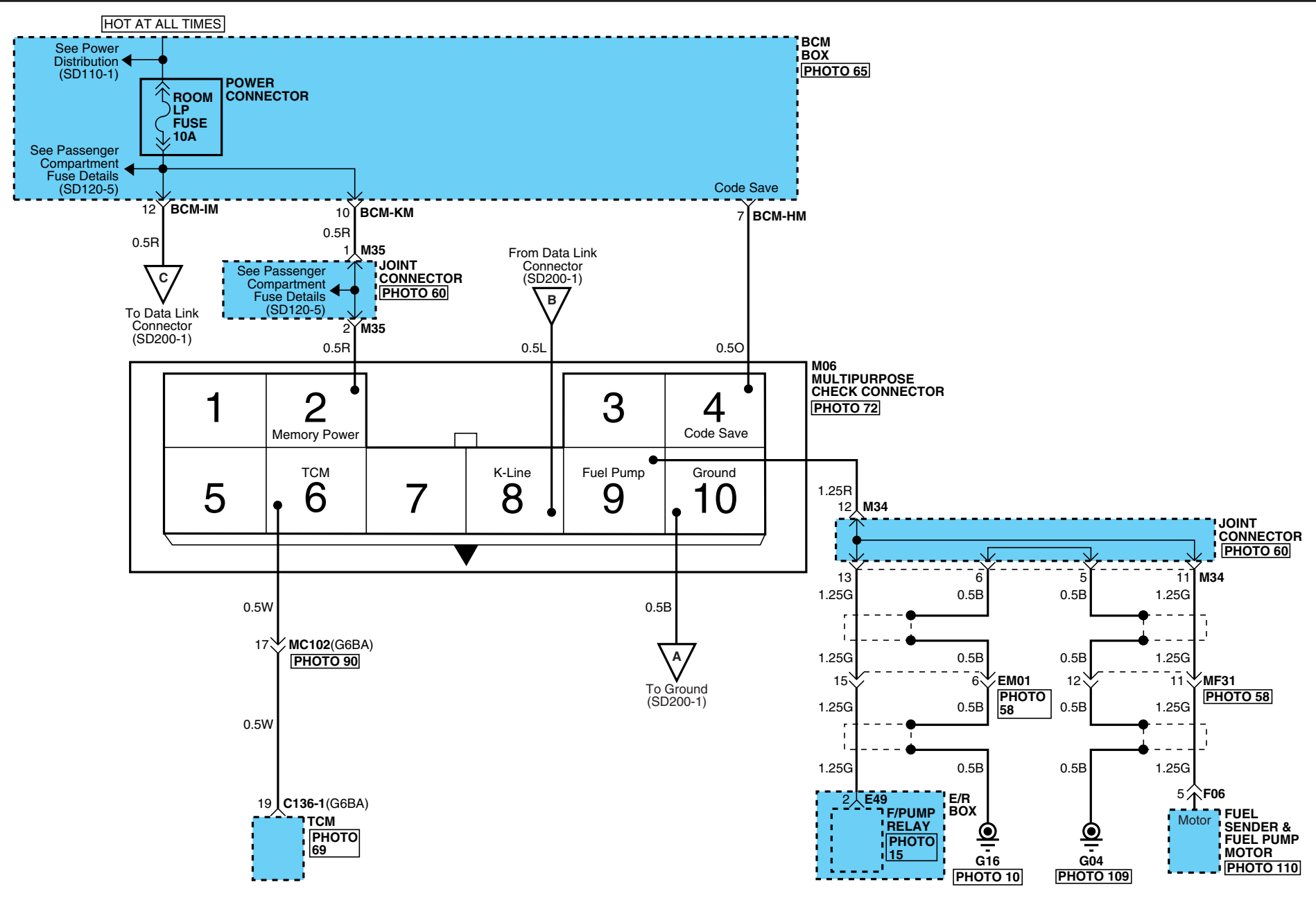

DATA LINK DETAILS

DATA LINK DETAILS (3)

SD200-3

A11

1	2	3	4	5	6	7	8	9	10	11	12	13	14	*	16	17	18	19	20	21	*	*	*	*	
*	*	*	*	*	*	*	*	33	34	*	*	37	*	*	*	*	*	*	*	45	46	*	*	*	*

AMP_ESPS_50F

C33-1

6	7	8	9	10	11	*	*	14	*	*	17	18	*	*	21	22	23	24	5	4
*	26	27	*	29	30	31	32	*	*	*	*	37	38	39	*	*	42	43	3	
44	45	*	47	48	*	50	51	52	*	54	55	56	*	58	59	60	61	62		
*	64	65	66	67	68	69	70	*	72	73	*	75	76	77	78	*	80	81	2	1

KET_ECU_81F_B_BOSCH

C133-1

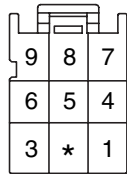

AMP_ECU_09F_B_134P

C133-4

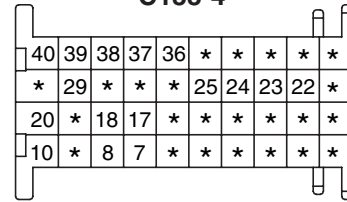

AMP_ECU_40F_B_134P

C136-1

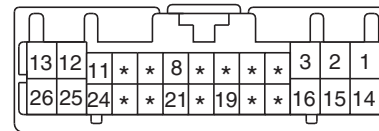

KET_0407_26F_W

C136-3

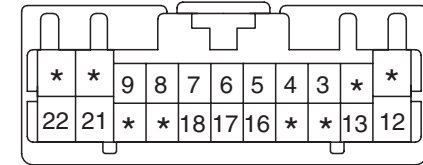

KET_0407_22F_W

C233

6	7	8	*	*	11	12	13	14	15	16	17	18	19	20	*	*	*	24	5	*
*	26	27	28	29	*	31	32	33	34	35	36	37	*	39	*	*	42	*	3	
44	45	46	47	48	49	50	51	52	53	*	55	*	57	*	59	60	61	*		
63	*	*	*	*	68	69	70	71	*	73	74	75	*	*	*	79	80	*	2	*

KET_ECU_81F_B_BOSCH

E33

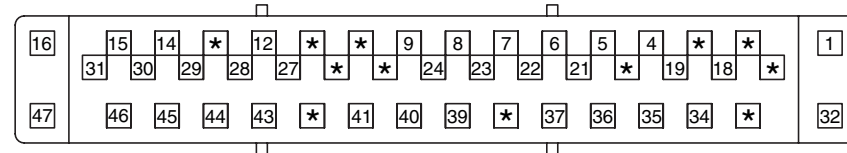

AMP_ESP_47F_L_UNIT

E37

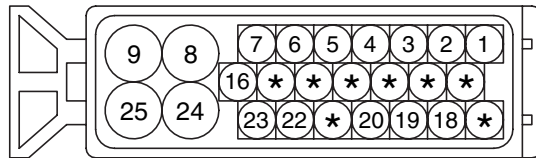

AMP_ABSWP_25F_B_GER

E23



KET_0901IWP_06M_Gr

E49

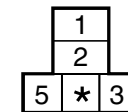

CR05F011

F06

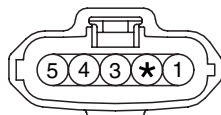

KET_0901IWP_05F_B_1

M06

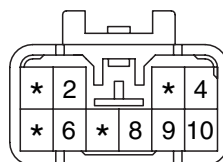

KET_0901I_10M_W

M07

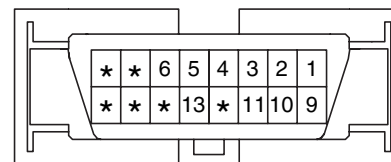

MLX_OBDII_16F_B_SIN

M26

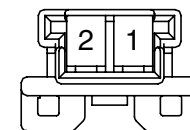

AMP_CAN_02F_W

DATA LINK DETAILS

DATA LINK DETAILS (4)

SD200-4

M42

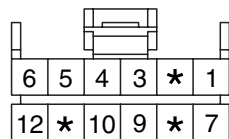

AMP_040M1_12F_B

BLANK

BLANK

BLANK

COOLING SYSTEM (1)

SD253-1

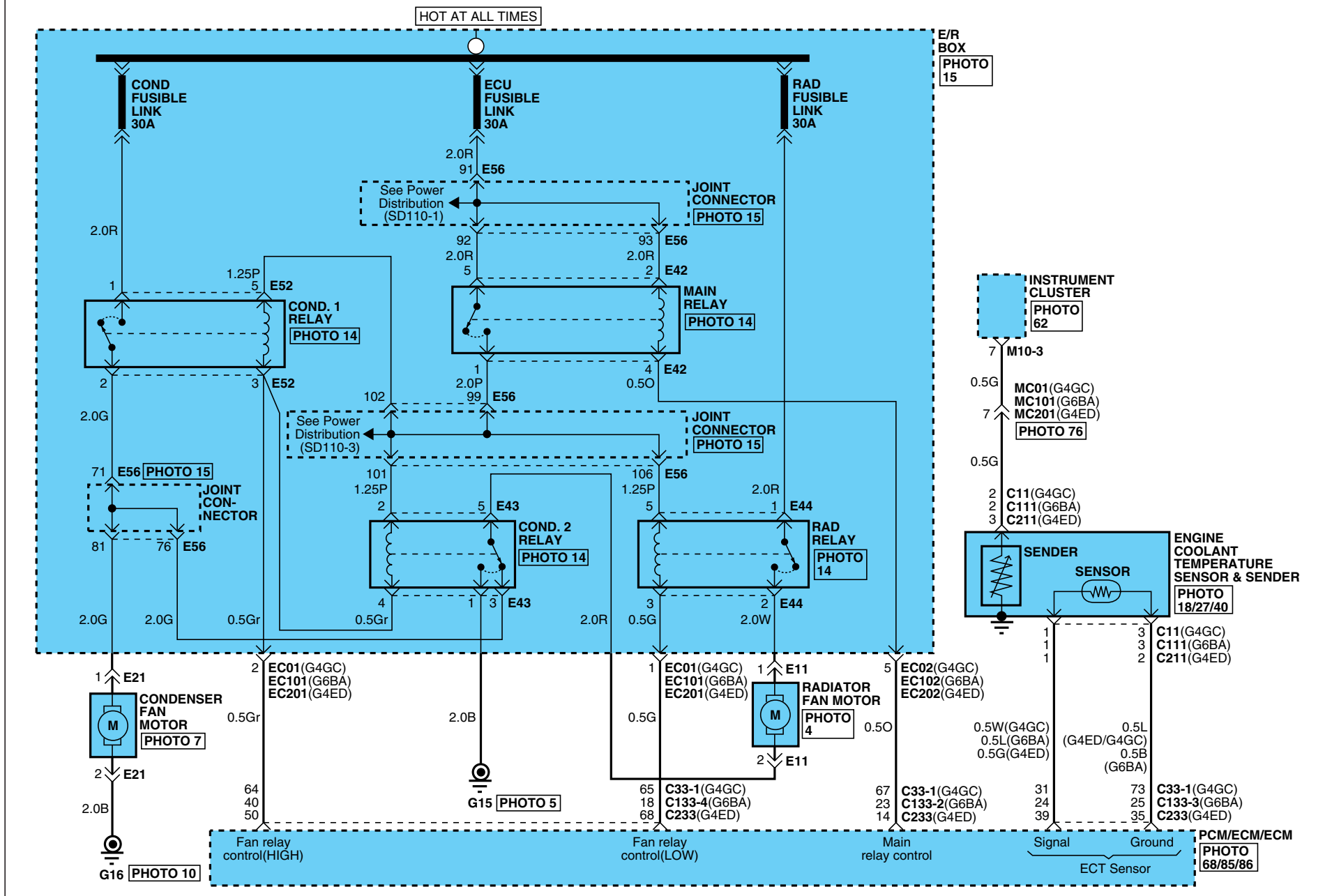

COOLING SYSTEM

COOLING SYSTEM (2)

SD253-2

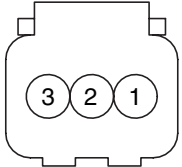
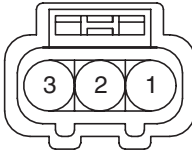
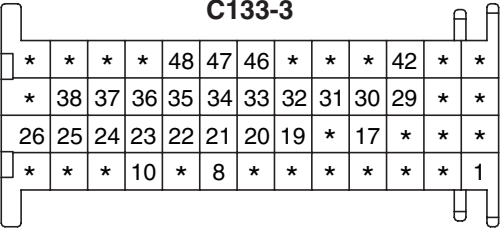
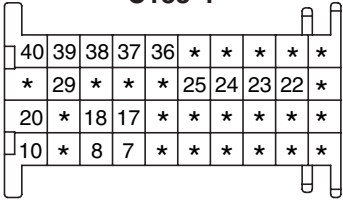
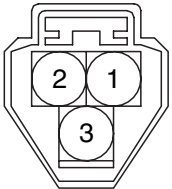
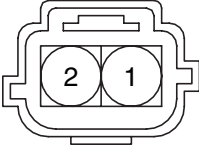
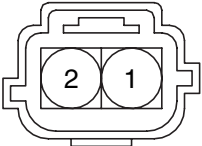
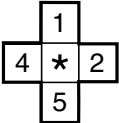
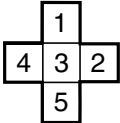
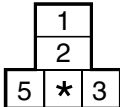
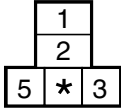
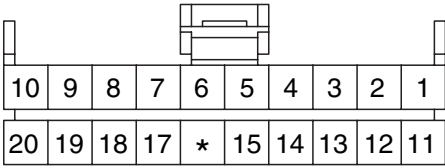
<p>C11</p>  <p>KUM_WTS_03F_B</p>	<p>C33-1</p> <table border="1" data-bbox="705 263 1529 422"> <tr><td>6</td><td>7</td><td>8</td><td>9</td><td>10</td><td>11</td><td>*</td><td>*</td><td>14</td><td>*</td><td>*</td><td>17</td><td>18</td><td>*</td><td>*</td><td>21</td><td>22</td><td>23</td><td>24</td><td>5</td><td>4</td></tr> <tr><td>*</td><td>26</td><td>27</td><td>*</td><td>29</td><td>30</td><td>31</td><td>32</td><td>*</td><td>*</td><td>*</td><td>*</td><td>37</td><td>38</td><td>39</td><td>*</td><td>*</td><td>42</td><td>43</td><td colspan="2" rowspan="2">3</td></tr> <tr><td>44</td><td>45</td><td>*</td><td>47</td><td>48</td><td>*</td><td>50</td><td>51</td><td>52</td><td>*</td><td>54</td><td>55</td><td>56</td><td>*</td><td>58</td><td>59</td><td>60</td><td>61</td><td>62</td></tr> <tr><td>*</td><td>64</td><td>65</td><td>66</td><td>67</td><td>68</td><td>69</td><td>70</td><td>*</td><td>72</td><td>73</td><td>*</td><td>75</td><td>76</td><td>77</td><td>78</td><td>*</td><td>80</td><td>81</td><td>2</td><td>1</td></tr> </table> <p>KET_ECU_81F_B_BOSCH</p>		6	7	8	9	10	11	*	*	14	*	*	17	18	*	*	21	22	23	24	5	4	*	26	27	*	29	30	31	32	*	*	*	*	37	38	39	*	*	42	43	3		44	45	*	47	48	*	50	51	52	*	54	55	56	*	58	59	60	61	62	*	64	65	66	67	68	69	70	*	72	73	*	75	76	77	78	*	80	81	2	1	<p>C111</p>  <p>KUM_62Z_03F_B_WTS</p>
6	7	8	9	10	11	*	*	14	*	*	17	18	*	*	21	22	23	24	5	4																																																																	
*	26	27	*	29	30	31	32	*	*	*	*	37	38	39	*	*	42	43	3																																																																		
44	45	*	47	48	*	50	51	52	*	54	55	56	*	58	59	60	61	62																																																																			
*	64	65	66	67	68	69	70	*	72	73	*	75	76	77	78	*	80	81	2	1																																																																	
<p>C133-2</p> <table border="1" data-bbox="257 499 553 699"> <tr><td>24</td><td>23</td><td>22</td><td>21</td><td>20</td><td>19</td></tr> <tr><td>18</td><td>17</td><td>16</td><td>15</td><td>14</td><td>13</td></tr> <tr><td>*</td><td>*</td><td>*</td><td>*</td><td>*</td><td>7</td></tr> <tr><td>*</td><td>*</td><td>*</td><td>*</td><td>*</td><td>1</td></tr> </table> <p>AMP_ECU_24F_B_134P</p>	24	23	22	21	20	19	18	17	16	15	14	13	*	*	*	*	*	7	*	*	*	*	*	1	<p>C133-3</p>  <p>AMP_ECU_52F_B_134P</p>		<p>C133-4</p>  <p>AMP_ECU_40F_B_134P</p>																																																										
24	23	22	21	20	19																																																																																
18	17	16	15	14	13																																																																																
*	*	*	*	*	7																																																																																
*	*	*	*	*	1																																																																																
<p>C211</p>  <p>KUM_NMWP_03F_B</p>	<p>C233</p> <table border="1" data-bbox="701 794 1525 954"> <tr><td>6</td><td>7</td><td>8</td><td>*</td><td>*</td><td>11</td><td>12</td><td>13</td><td>14</td><td>15</td><td>16</td><td>17</td><td>18</td><td>19</td><td>20</td><td>*</td><td>*</td><td>*</td><td>24</td><td>5</td><td>*</td></tr> <tr><td>*</td><td>26</td><td>27</td><td>28</td><td>29</td><td>*</td><td>31</td><td>32</td><td>33</td><td>34</td><td>35</td><td>36</td><td>37</td><td>*</td><td>39</td><td>*</td><td>*</td><td>42</td><td>*</td><td colspan="2" rowspan="2">3</td></tr> <tr><td>44</td><td>45</td><td>46</td><td>47</td><td>48</td><td>49</td><td>50</td><td>51</td><td>52</td><td>53</td><td>*</td><td>55</td><td>*</td><td>57</td><td>*</td><td>59</td><td>60</td><td>61</td><td>*</td></tr> <tr><td>63</td><td>*</td><td>*</td><td>*</td><td>*</td><td>68</td><td>69</td><td>70</td><td>71</td><td>*</td><td>73</td><td>74</td><td>75</td><td>*</td><td>*</td><td>*</td><td>79</td><td>80</td><td>*</td><td>2</td><td>*</td></tr> </table> <p>KET_ECU_81F_B_BOSCH</p>		6	7	8	*	*	11	12	13	14	15	16	17	18	19	20	*	*	*	24	5	*	*	26	27	28	29	*	31	32	33	34	35	36	37	*	39	*	*	42	*	3		44	45	46	47	48	49	50	51	52	53	*	55	*	57	*	59	60	61	*	63	*	*	*	*	68	69	70	71	*	73	74	75	*	*	*	79	80	*	2	*	<p>E11</p>  <p>KUM_WWP_02F_B</p>
6	7	8	*	*	11	12	13	14	15	16	17	18	19	20	*	*	*	24	5	*																																																																	
*	26	27	28	29	*	31	32	33	34	35	36	37	*	39	*	*	42	*	3																																																																		
44	45	46	47	48	49	50	51	52	53	*	55	*	57	*	59	60	61	*																																																																			
63	*	*	*	*	68	69	70	71	*	73	74	75	*	*	*	79	80	*	2	*																																																																	
<p>E21</p>  <p>KUM_WWP_02F_B</p>	<p>E42</p>  <p>CR05F019</p>	<p>E43</p>  <p>CR05F019</p>	<p>E44</p>  <p>CR05F011</p>																																																																																		
<p>E52</p>  <p>CR05F011</p>	<p>M10-3</p>  <p>AMP_040M1_20F_B</p>		<p>BLANK</p>																																																																																		

MFI CONTROL SYSTEM (G4GC) (1)

SD313-1

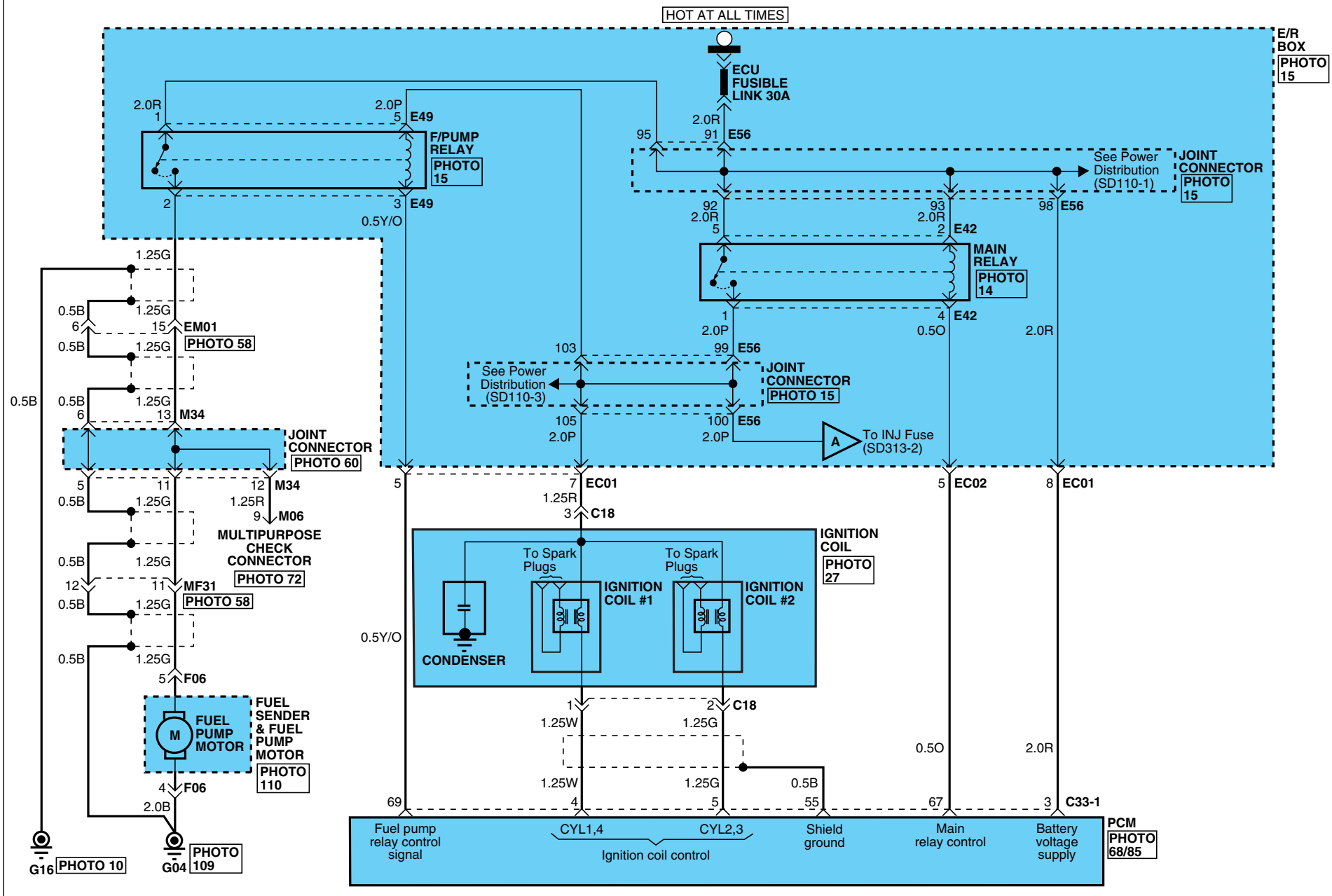

MFI CONTROL SYSTEM

MFI CONTROL SYSTEM (G4GC) (3)

SD313-3

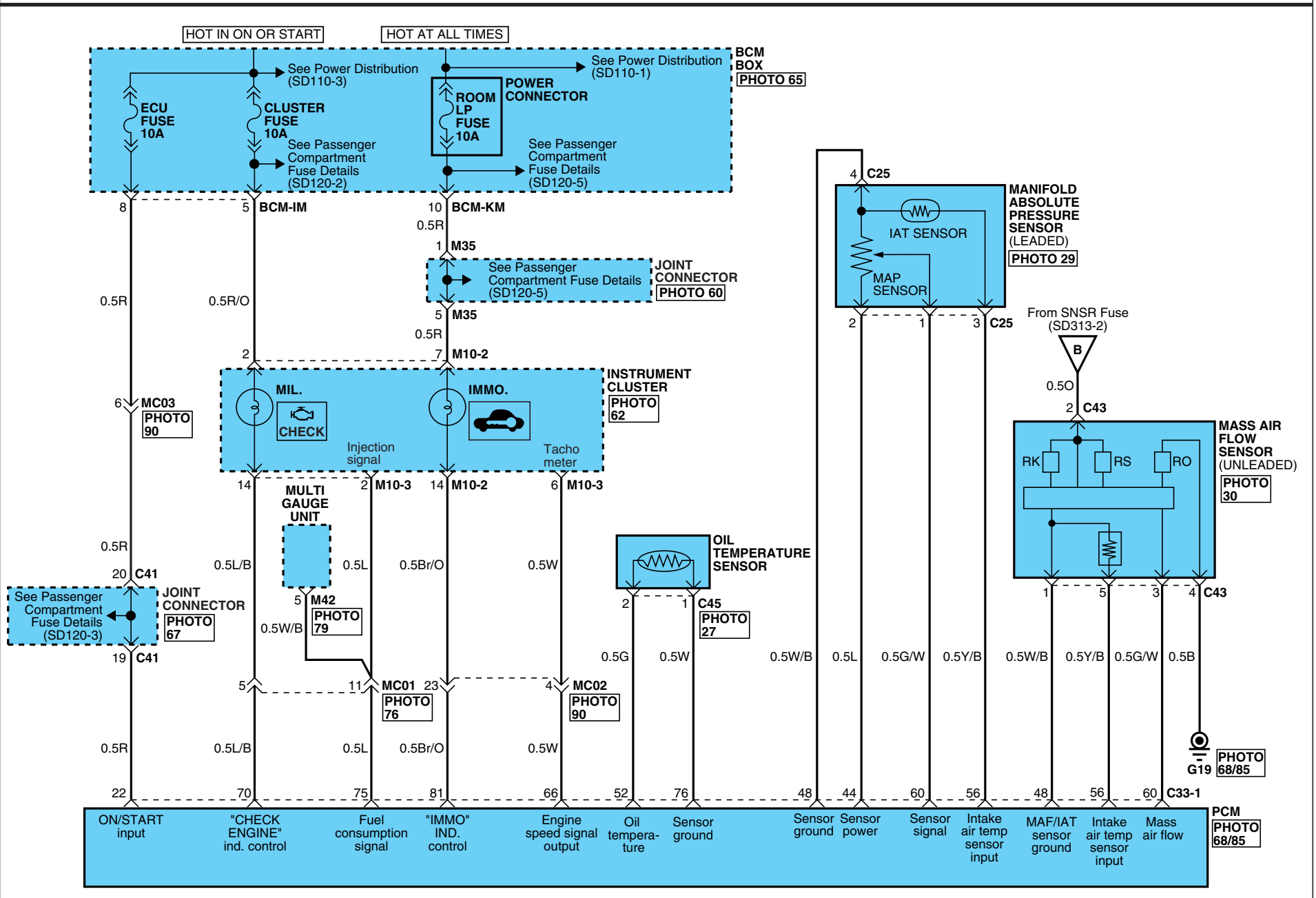

MFI CONTROL SYSTEM

MFI CONTROL SYSTEM (G4GC) (4)



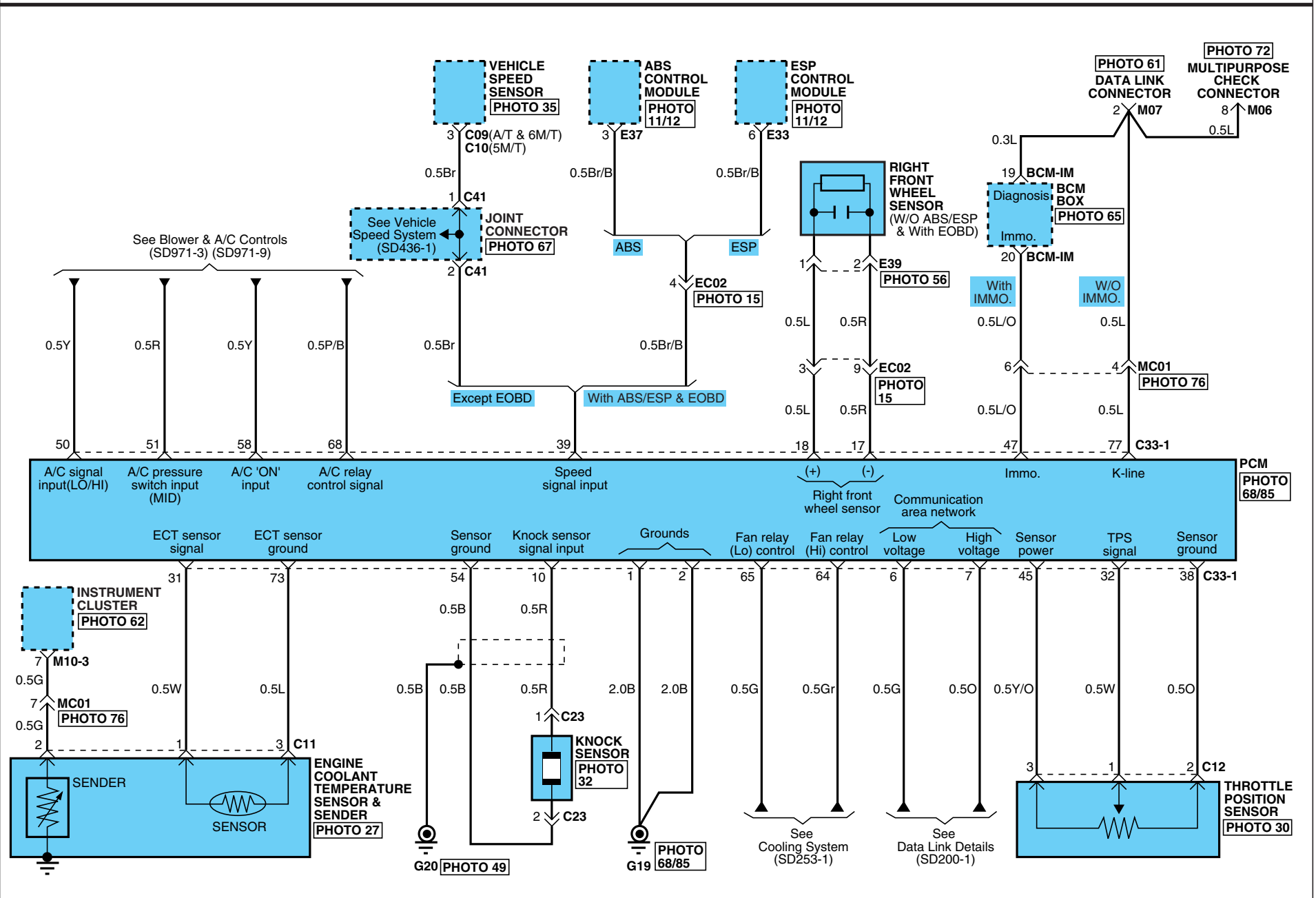

SD313-4

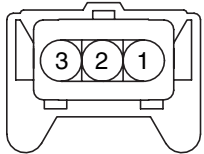
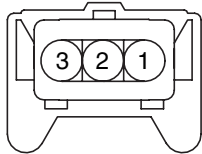
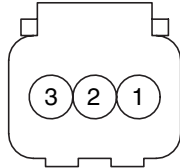
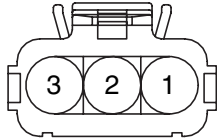
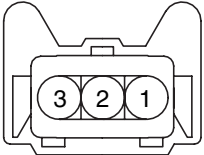
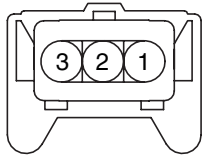

MFI CONTROL SYSTEM

MFI CONTROL SYSTEM (G4GC) (5)

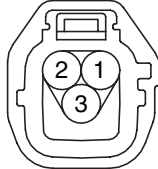
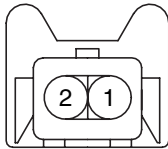
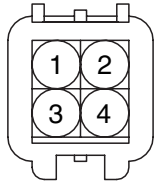
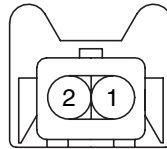
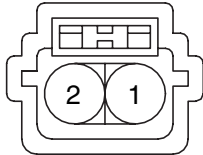
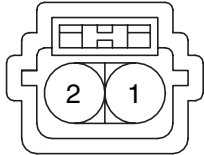
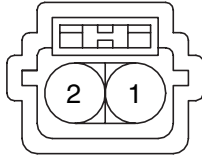
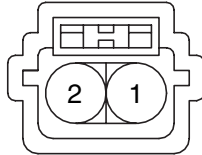
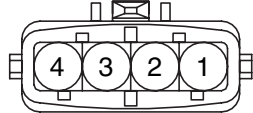
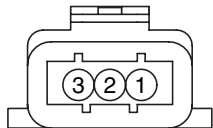
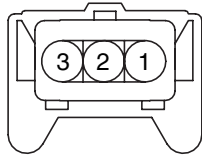
SD313-5

<p>C09</p>  <p>AMP_JPT_03F_B_S1</p>	<p>C10</p>  <p>AMP_JPT_03F_B_S1</p>	<p>C11</p>  <p>KUM_WTS_03F_B</p>	<p>C12</p>  <p>AMP_JPT_03F_B_BOSCH</p>
<p>C13</p>  <p>AMP_JPT_03F_Gr_R1</p>	<p>C14</p>  <p>AMP_JPT_03F_B_S1</p>	<p>C16</p>  <p>AMP_EJWP_04F_B</p>	<p>C18</p>  <p>KET_090IWP_03F_W</p>
<p>C21</p>  <p>AMP_JPT_02F_B</p>	<p>C22</p>  <p>AUM_NMWP_04F_B</p>	<p>C23</p>  <p>AMP_JPT_02F_B</p>	<p>C24-1</p>  <p>KUM_NDWP_02F_Gr</p>
<p>C24-2</p>  <p>KUM_NDWP_02F_Gr</p>	<p>C24-3</p>  <p>KUM_NDWP_02F_Gr</p>	<p>C24-4</p>  <p>KUM_NDWP_02F_Gr</p>	<p>C25</p>  <p>AMP_JPT_04F_B_BOSCH</p>
<p>C26</p>  <p>BSH_ISA_03F_Gr</p>	<p>C26-A</p>  <p>AMP_JPT_03F_B_S1</p>	<p>C30</p>  <p>KET_090WP_02F_B_L</p>	<p>BLANK</p>

MFI CONTROL SYSTEM

MFI CONTROL SYSTEM (G4GC) (6)

SD313-6

C33-1

6	7	8	9	10	11	*	*	14	*	*	17	18	*	*	21	22	23	24	5	4
*	26	27	*	29	30	31	32	*	*	*	*	37	38	39	*	*	42	43	3	
44	45	*	47	48	*	50	51	52	*	54	55	56	*	58	59	60	61	62		
*	64	65	66	67	68	69	70	*	72	73	*	75	76	77	78	*	80	81	2	1

KET_ECU_81F_B_BOSCH

C43

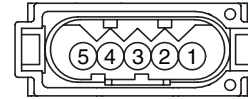

KSP_VDACODEB_05F_B

C45

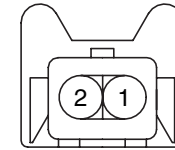

AMP_JPT_02F_B

E33

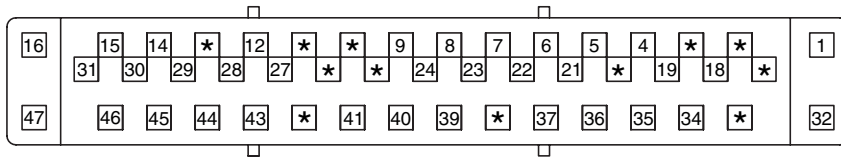

AMP_ESP_47F_L_UNIT

E37

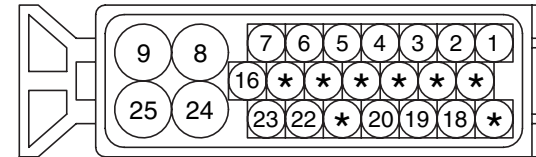

AMP_ABSWP_25F_B_GER

E39

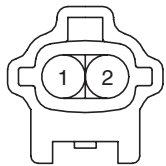

KET_090IWP_02M_Gr

E42

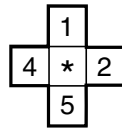

CR05F019

E49

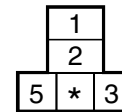

CR05F011

F06

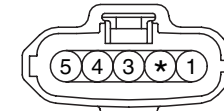

KET_090IWP_05F_B_1

M06

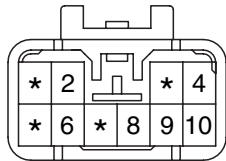

KET_090II_10M_W

M07

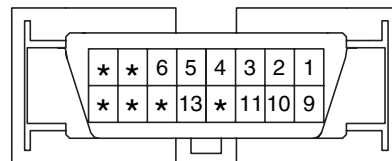

MLX_OBDII_16F_B_SIN

M10-2

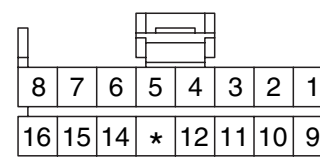

AMP_040M1_16F_B

M10-3

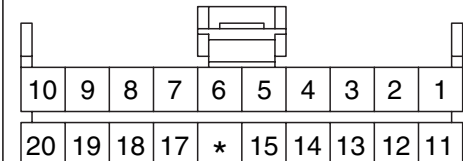

AMP_040M1_20F_B

M42

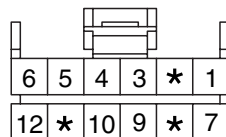

AMP_040M1_12F_B

BLANK

BLANK

BLANK

MFI CONTROL SYSTEM

MFI CONTROL SYSTEM (G6BA) (2)

SD313-8

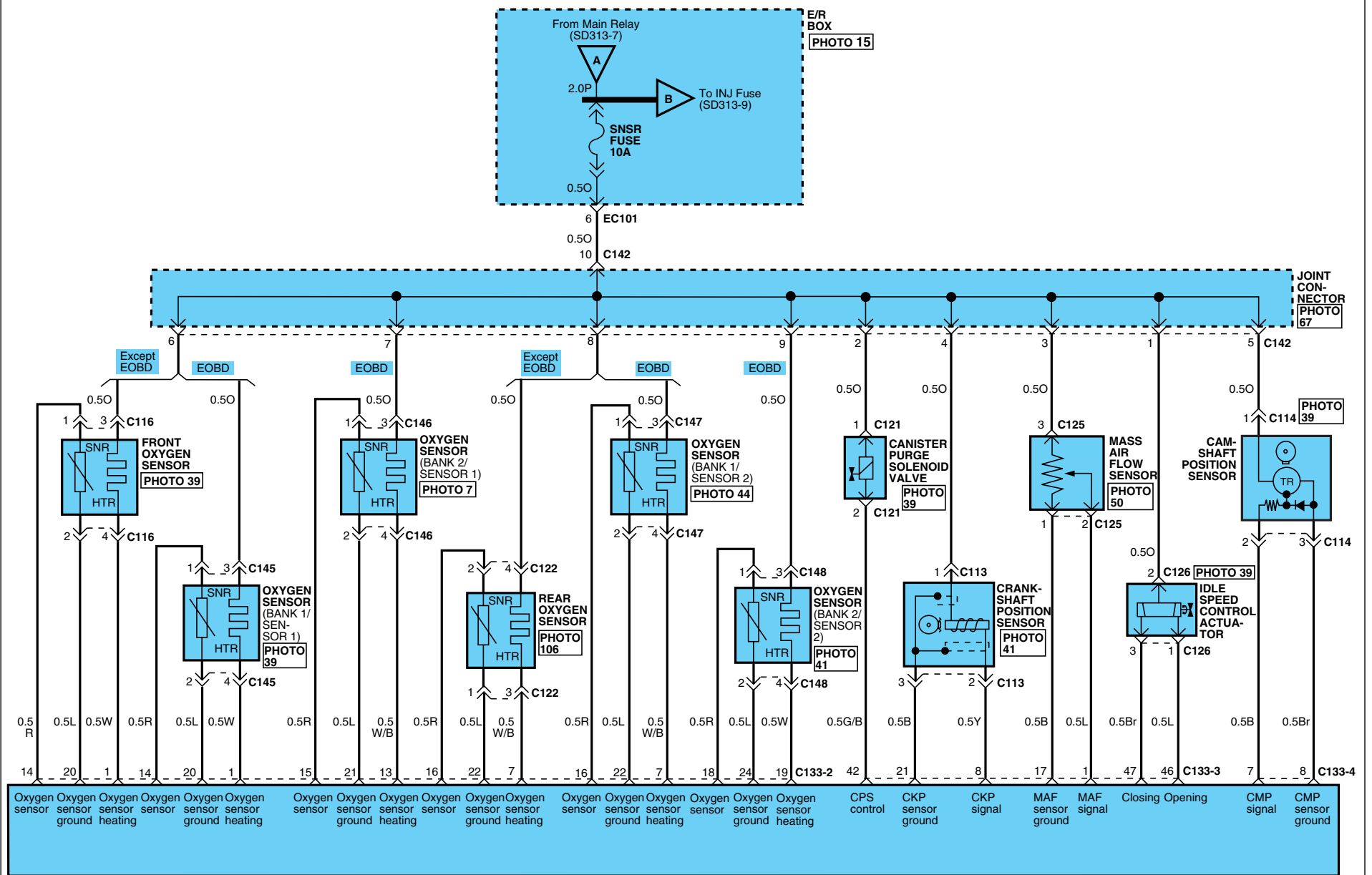
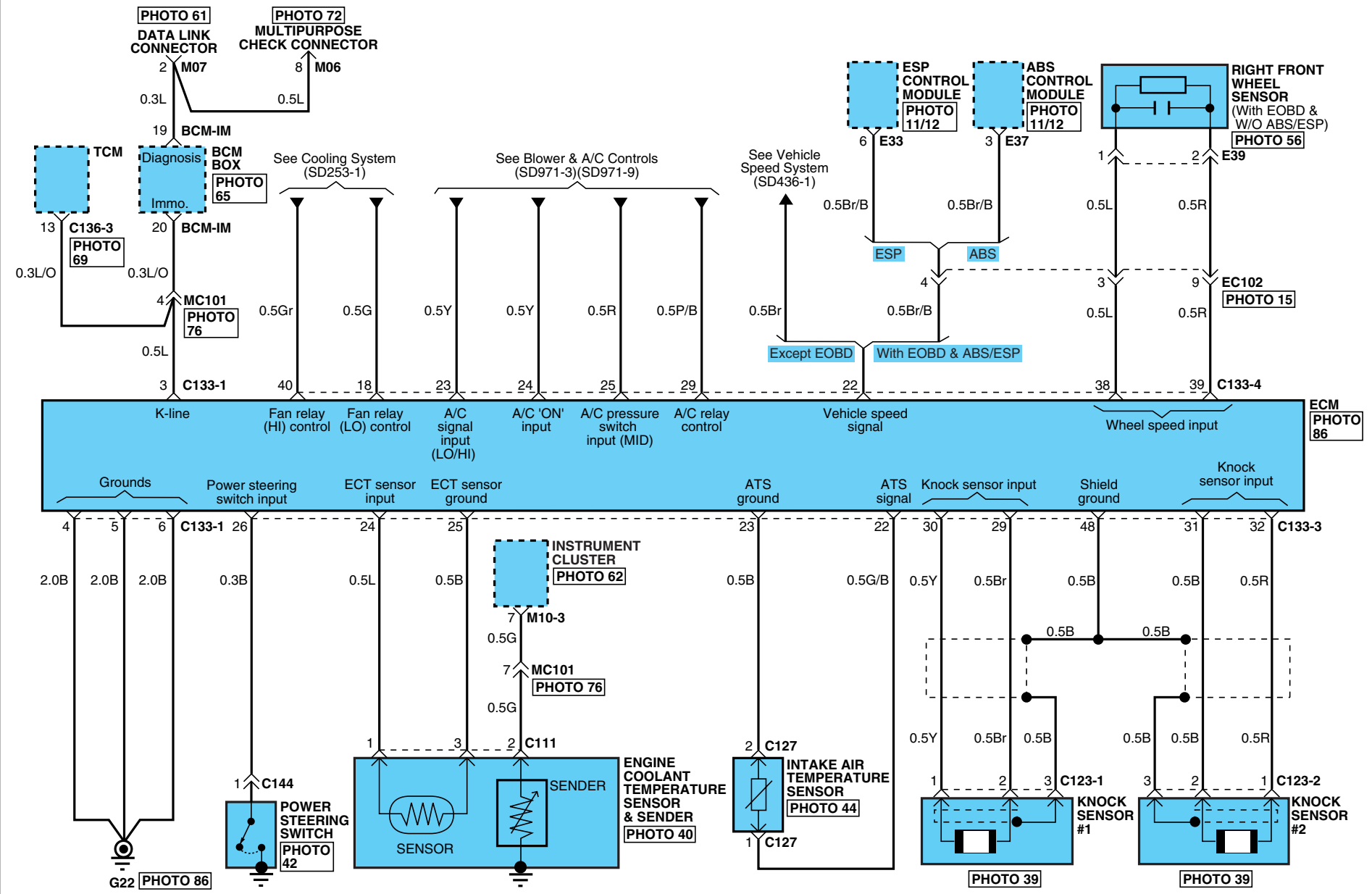

PHOTO 86 ECM

MFI CONTROL SYSTEM

MFI CONTROL SYSTEM (G6BA) (4)

SD313-10



MFI CONTROL SYSTEM

MFI CONTROL SYSTEM (G6BA) (5)

SD313-11

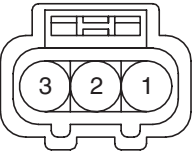
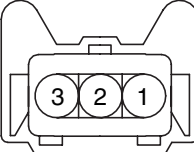
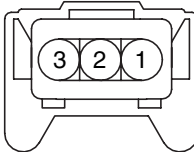
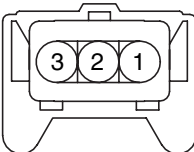
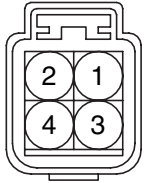
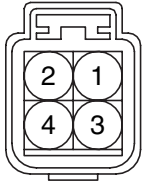
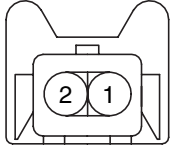
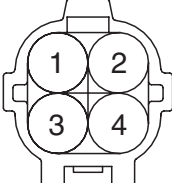
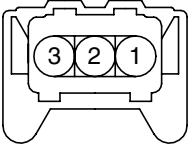
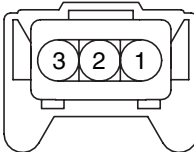
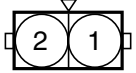
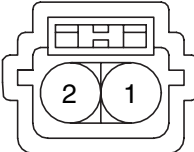
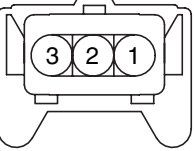
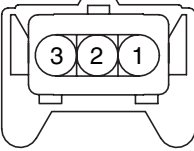
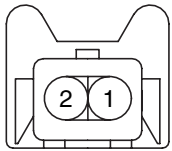
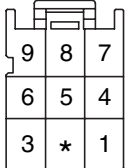
<p>C111</p>  <p>KUM_62Z_03F_B_WTS</p>	<p>C112</p>  <p>AMP_JPT_03F_Gr_R1</p>	<p>C113</p>  <p>AMP_JPT_03F_B_S2</p>	<p>C114</p>  <p>AMP_JPT_03F_G_S1</p>																																																																																																																			
<p>C116</p>  <p>KUM_NMWP_04F_Gr</p>	<p>C118</p>  <p>KUM_NMWP_04F_B</p>	<p>C121</p>  <p>AMP_JPT_02F_B</p>	<p>C122</p>  <p>KET_SWP_04M_B</p>																																																																																																																			
<p>C123-1</p>  <p>AMP_JPT_03F_Gr_R2</p>	<p>C123-2</p>  <p>AMP_JPT_03F_L_S2</p>	<p>C124-1,3,5</p>  <p>CR02F016</p>	<p>C124-2,4,6</p>  <p>KUM_NDWP_02F_Gr</p>																																																																																																																			
<p>C125</p>  <p>AMP_JPT_03F_B_S1</p>	<p>C126</p>  <p>AMP_JPT_03F_B_S1</p>	<p>C127</p>  <p>AMP_JPT_02F_B</p>	<p>C133-1</p>  <p>AMP_ECU_09F_B_134P</p>																																																																																																																			
<p>C133-2</p> <table border="1" data-bbox="255 1281 555 1481"> <tr><td>24</td><td>23</td><td>22</td><td>21</td><td>20</td><td>19</td></tr> <tr><td>18</td><td>17</td><td>16</td><td>15</td><td>14</td><td>13</td></tr> <tr><td>*</td><td>*</td><td>*</td><td>*</td><td>*</td><td>7</td></tr> <tr><td>*</td><td>*</td><td>*</td><td>*</td><td>*</td><td>1</td></tr> </table> <p>AMP_ECU_24F_B_134P</p>	24	23	22	21	20	19	18	17	16	15	14	13	*	*	*	*	*	7	*	*	*	*	*	1	<p>C133-3</p> <table border="1" data-bbox="869 1273 1370 1501"> <tr><td>*</td><td>*</td><td>*</td><td>*</td><td>48</td><td>47</td><td>46</td><td>*</td><td>*</td><td>*</td><td>42</td><td>*</td><td>*</td></tr> <tr><td>*</td><td>38</td><td>37</td><td>36</td><td>35</td><td>34</td><td>33</td><td>32</td><td>31</td><td>30</td><td>29</td><td>*</td><td>*</td></tr> <tr><td>26</td><td>25</td><td>24</td><td>23</td><td>22</td><td>21</td><td>20</td><td>19</td><td>*</td><td>17</td><td>*</td><td>*</td><td>*</td></tr> <tr><td>*</td><td>*</td><td>*</td><td>10</td><td>*</td><td>8</td><td>*</td><td>*</td><td>*</td><td>*</td><td>*</td><td>*</td><td>1</td></tr> </table> <p>AMP_ECU_52F_B_134P</p>	*	*	*	*	48	47	46	*	*	*	42	*	*	*	38	37	36	35	34	33	32	31	30	29	*	*	26	25	24	23	22	21	20	19	*	17	*	*	*	*	*	*	10	*	8	*	*	*	*	*	*	1	<p>C133-4</p> <table border="1" data-bbox="1659 1281 2002 1481"> <tr><td>40</td><td>39</td><td>38</td><td>37</td><td>36</td><td>*</td><td>*</td><td>*</td><td>*</td><td>*</td></tr> <tr><td>*</td><td>29</td><td>*</td><td>*</td><td>*</td><td>25</td><td>24</td><td>23</td><td>22</td><td>*</td></tr> <tr><td>20</td><td>*</td><td>18</td><td>17</td><td>*</td><td>*</td><td>*</td><td>*</td><td>*</td><td>*</td></tr> <tr><td>10</td><td>*</td><td>8</td><td>7</td><td>*</td><td>*</td><td>*</td><td>*</td><td>*</td><td>*</td></tr> </table> <p>AMP_ECU_40F_B_134P</p>	40	39	38	37	36	*	*	*	*	*	*	29	*	*	*	25	24	23	22	*	20	*	18	17	*	*	*	*	*	*	10	*	8	7	*	*	*	*	*	*
24	23	22	21	20	19																																																																																																																	
18	17	16	15	14	13																																																																																																																	
*	*	*	*	*	7																																																																																																																	
*	*	*	*	*	1																																																																																																																	
*	*	*	*	48	47	46	*	*	*	42	*	*																																																																																																										
*	38	37	36	35	34	33	32	31	30	29	*	*																																																																																																										
26	25	24	23	22	21	20	19	*	17	*	*	*																																																																																																										
*	*	*	10	*	8	*	*	*	*	*	*	1																																																																																																										
40	39	38	37	36	*	*	*	*	*																																																																																																													
*	29	*	*	*	25	24	23	22	*																																																																																																													
20	*	18	17	*	*	*	*	*	*																																																																																																													
10	*	8	7	*	*	*	*	*	*																																																																																																													

MFI CONTROL SYSTEM

MFI CONTROL SYSTEM (G6BA) (6)

SD313-12

C133-5

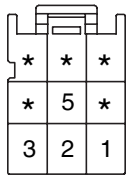

AMP_ECU_09F_Gr_134P

C136-3

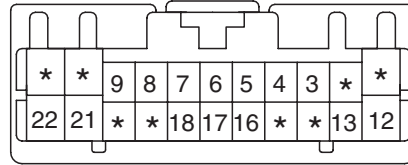

KET_0407_22F_W

C144

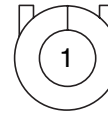

KET_156_01F_W_TML

C145,C146,C147,C148

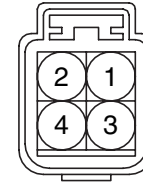

KUM_NMWP_04F_Gr

E33

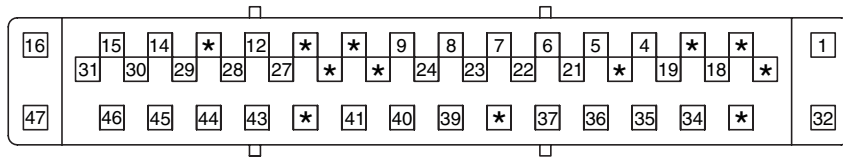

AMP_ESP_47F_L_UNIT

E37

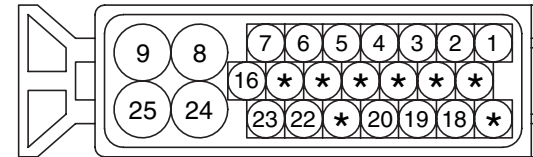

AMP_ABSWP_25F_B_GER

E39

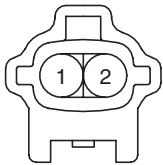

KET_090IWP_02M_Gr

E42

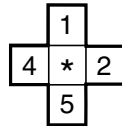

CR05F019

E49

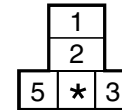

CR05F011

F06

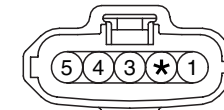

KET_090IWP_05F_B_1

M06

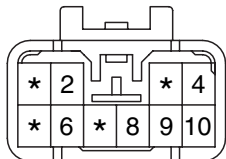

KET_090I1_10M_W

M07

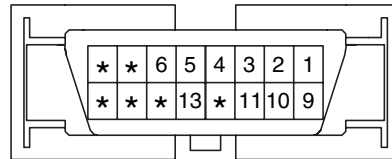

MLX_OBDII_16F_B_SIN

M10-2

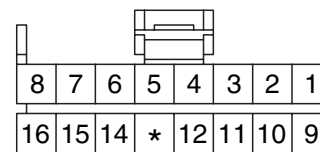

AMP_040M1_16F_B

M10-3

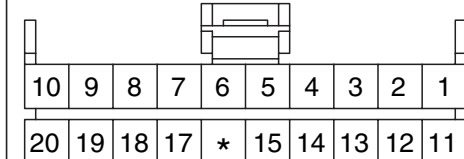

AMP_040M1_20F_B

M42

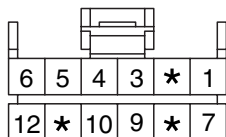

AMP_040M1_12F_B

BLANK

BLANK

BLANK

MFI CONTROL SYSTEM

MFI CONTROL SYSTEM (G4ED) (3)

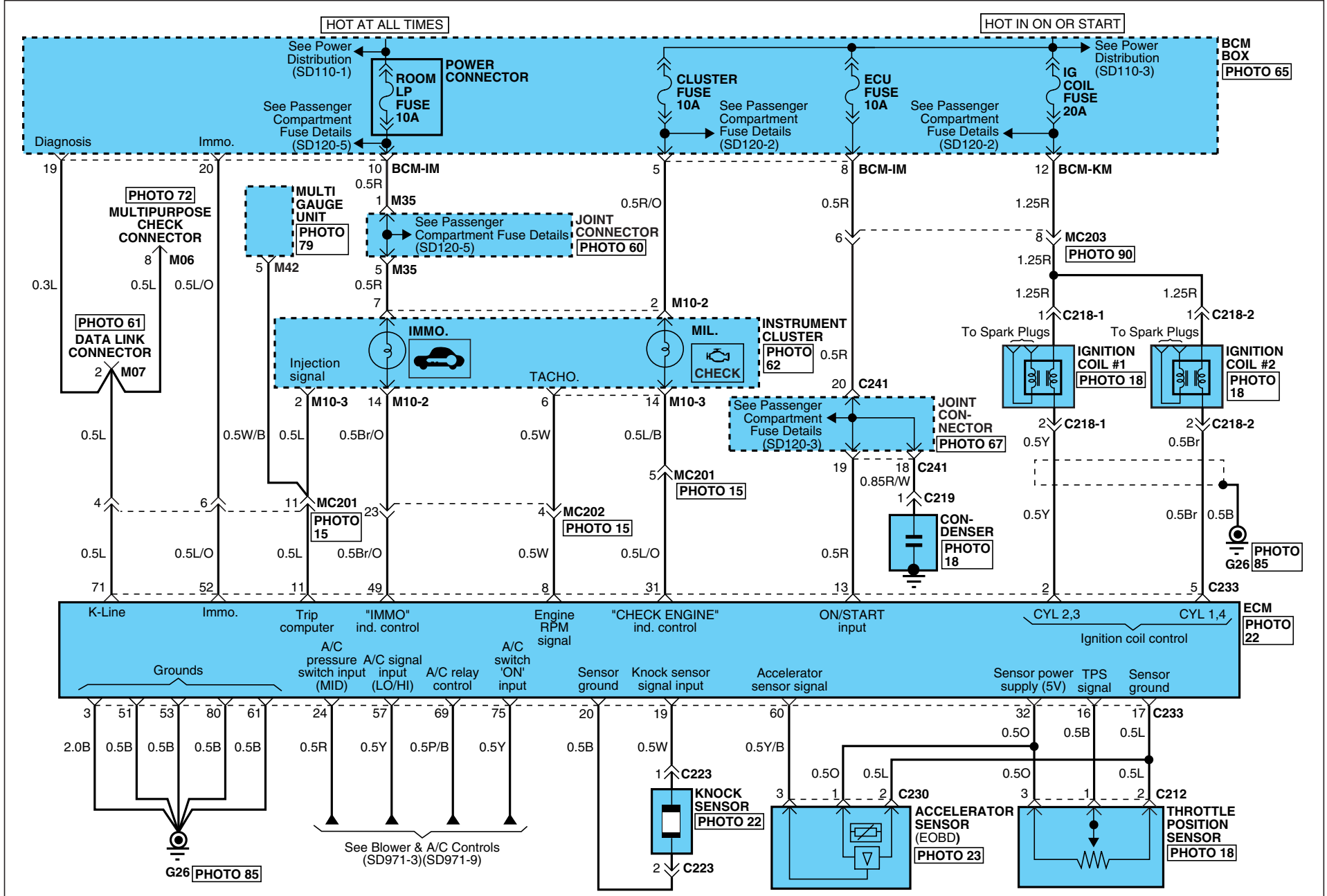

SD313-15



MFI CONTROL SYSTEM

MFI CONTROL SYSTEM (G4ED) (4)

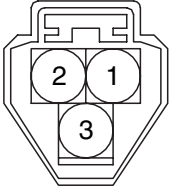
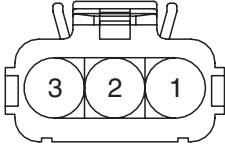
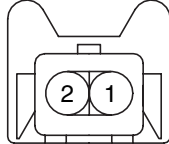
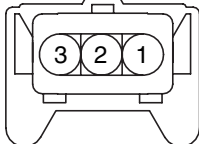
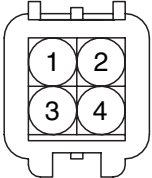
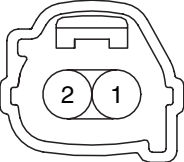
SD313-16

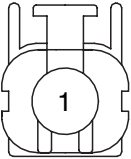
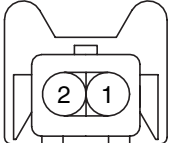
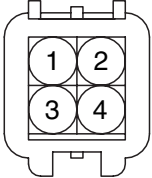
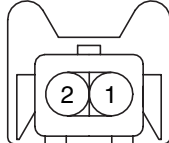
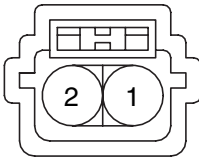
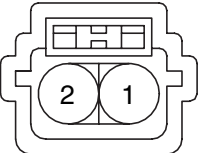
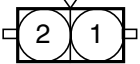
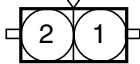
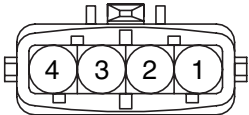
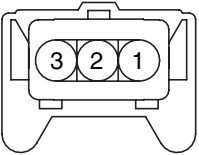
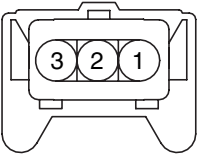
<p>C211</p>  <p>KUM_NMWP_03F_B</p>	<p>C212</p>  <p>AMP_JPT_03F_B_BOSCH</p>	<p>C213</p>  <p>AMP_JPT_02F_B</p>	<p>C214</p>  <p>AMP_JPT_03F_B_S1</p>																																																																																				
<p>C216</p>  <p>KUM_NMWP_04M_B</p>	<p>C218-1</p>  <p>KET_090IWP_02F_Gr_R</p>	<p>C218-2</p>  <p>KET_090IWP_02F_B_L</p>	<p>C219</p>  <p>KET_58X_01F_Gr</p>																																																																																				
<p>C221</p>  <p>AMP_JPT_02F_B</p>	<p>C222</p>  <p>KUM_NMWP_04M_B</p>	<p>C223</p>  <p>AMP_JPT_02F_B</p>	<p>C224-1</p>  <p>KUM_NDWP_02F_Gr</p>																																																																																				
<p>C224-2</p>  <p>KUM_NDWP_02F_Gr</p>	<p>C224-3</p>  <p>CR02F097</p>	<p>C224-4</p>  <p>CR02F097</p>	<p>C225</p>  <p>AMP_JPT_04F_B_BOSCH</p>																																																																																				
<p>C226</p>  <p>AMP_JPT_03F_B_S1</p>	<p>C230</p>  <p>AMP_JPT_03F_B_S1</p>	<p>C233</p> <table border="1" data-bbox="1176 1305 2004 1465"> <tr> <td>6</td><td>7</td><td>8</td><td>*</td><td>*</td><td>11</td><td>12</td><td>13</td><td>14</td><td>15</td><td>16</td><td>17</td><td>18</td><td>19</td><td>20</td><td>*</td><td>*</td><td>*</td><td>24</td><td>5</td><td>*</td> </tr> <tr> <td>*</td><td>26</td><td>27</td><td>28</td><td>29</td><td>*</td><td>31</td><td>32</td><td>33</td><td>34</td><td>35</td><td>36</td><td>37</td><td>*</td><td>39</td><td>*</td><td>*</td><td>42</td><td>*</td><td></td><td></td> </tr> <tr> <td>44</td><td>45</td><td>46</td><td>47</td><td>48</td><td>49</td><td>50</td><td>51</td><td>52</td><td>53</td><td>*</td><td>55</td><td>*</td><td>57</td><td>*</td><td>59</td><td>60</td><td>61</td><td>*</td><td>3</td><td></td> </tr> <tr> <td>63</td><td>*</td><td>*</td><td>*</td><td>*</td><td>68</td><td>69</td><td>70</td><td>71</td><td>*</td><td>73</td><td>74</td><td>75</td><td>*</td><td>*</td><td>*</td><td>79</td><td>80</td><td>*</td><td>2</td><td>*</td> </tr> </table> <p>KET_ECU_81F_B_BOSCH</p>		6	7	8	*	*	11	12	13	14	15	16	17	18	19	20	*	*	*	24	5	*	*	26	27	28	29	*	31	32	33	34	35	36	37	*	39	*	*	42	*			44	45	46	47	48	49	50	51	52	53	*	55	*	57	*	59	60	61	*	3		63	*	*	*	*	68	69	70	71	*	73	74	75	*	*	*	79	80	*	2	*
6	7	8	*	*	11	12	13	14	15	16	17	18	19	20	*	*	*	24	5	*																																																																			
*	26	27	28	29	*	31	32	33	34	35	36	37	*	39	*	*	42	*																																																																					
44	45	46	47	48	49	50	51	52	53	*	55	*	57	*	59	60	61	*	3																																																																				
63	*	*	*	*	68	69	70	71	*	73	74	75	*	*	*	79	80	*	2	*																																																																			

MFI CONTROL SYSTEM

MFI CONTROL SYSTEM (G4ED) (5)

SD313-17

E42

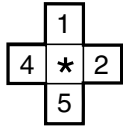

CR05F019

E49

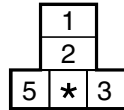

CR05F011

F06

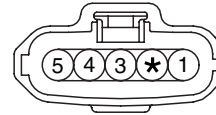

KET_090IWP_05F_B_I

M06

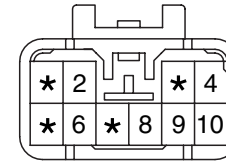

KET_090II_10M_W

M07

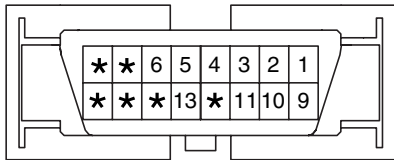

MLX_OBDII_16F_B_SIN

M10-2

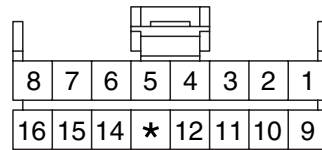

AMP_040M1_16F_B

M10-3

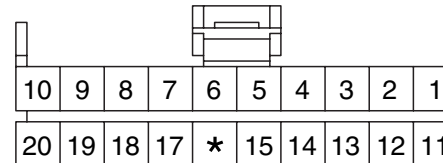

AMP_040M1_20F_B

M42

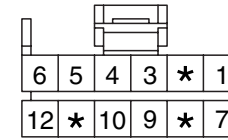

AMP_040M1_12F_B

MFI CONTROL SYSTEM

MFI CONTROL SYSTEM (G4ED) (6)

SD313-18







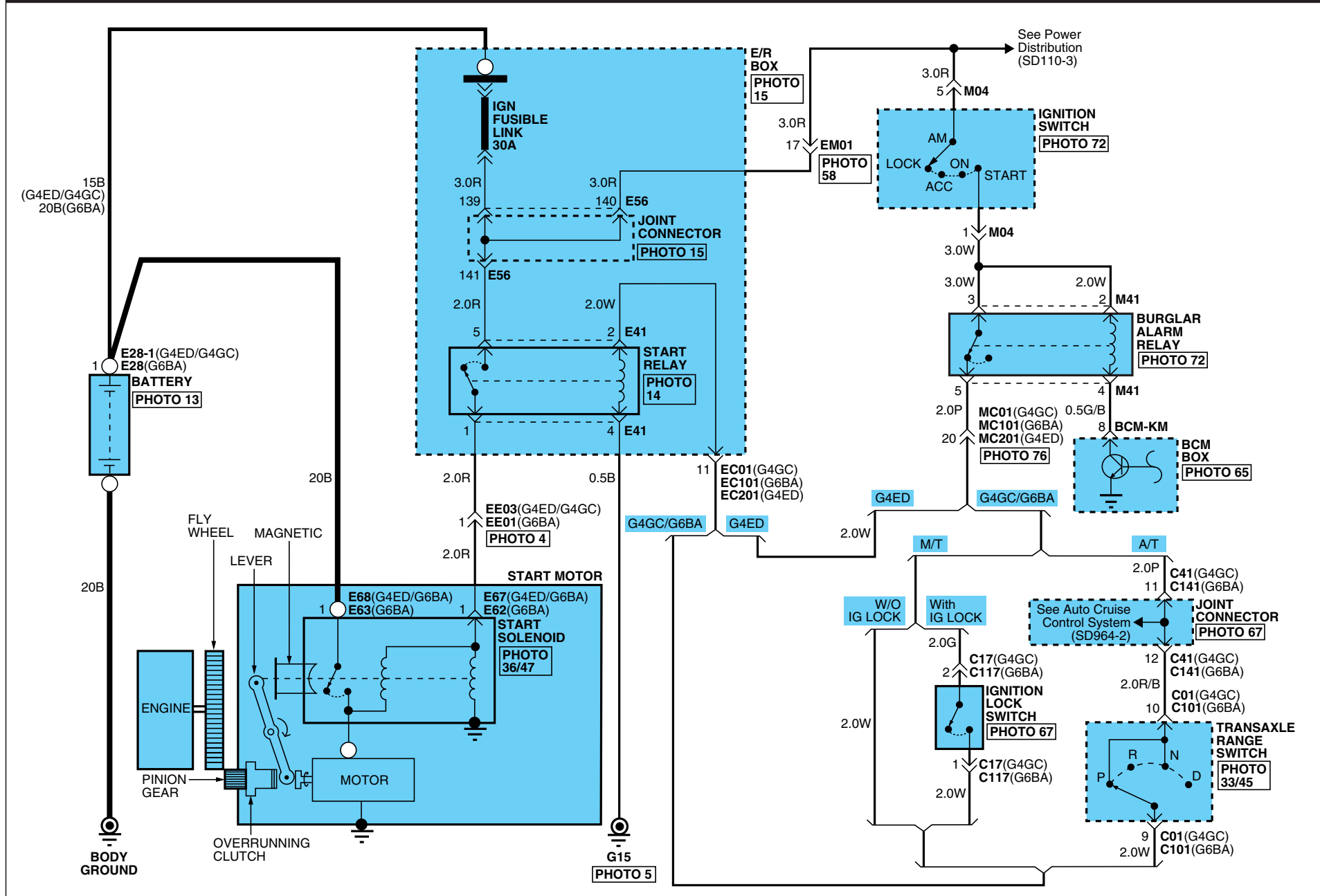

MEMO

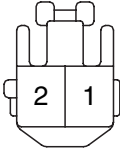
STARTING SYSTEM (1)

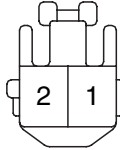
SD360-1

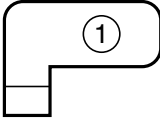
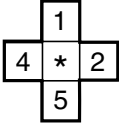

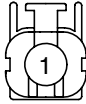
STARTING SYSTEM

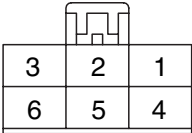
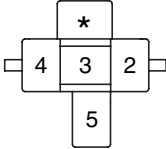
STARTING SYSTEM (2)			SD360-2
<p>C01</p>  <p>KET_SSD_10F_B_A</p>	<p>C17</p>  <p>KET_090II_02F_W_L</p>	<p>C101</p>  <p>KET_SSD_10F_B_A</p>	<p>C117</p>  <p>KET_090II_02F_W_L</p>
<p>E28</p>  <p>CR01F005</p>	<p>E28-1</p>  <p>CR01F051</p>	<p>E41</p>  <p>CR05F019</p>	<p>E62</p>  <p>CR01F006</p>
<p>E63</p>  <p>CR01F002</p>	<p>E67(G4GC)</p>  <p>KET250_WP_1F</p>	<p>E67(G4ED)</p>  <p>CR01F006</p>	<p>E68</p>  <p>CR01F002</p>
<p>M04</p>  <p>KUM_DSD_06F_W</p>	<p>M41</p>  <p>KET_250_05F_B_RLY</p>	<p>BLANK</p>	<p>BLANK</p>

CHARGING SYSTEM (1)

SD373-1

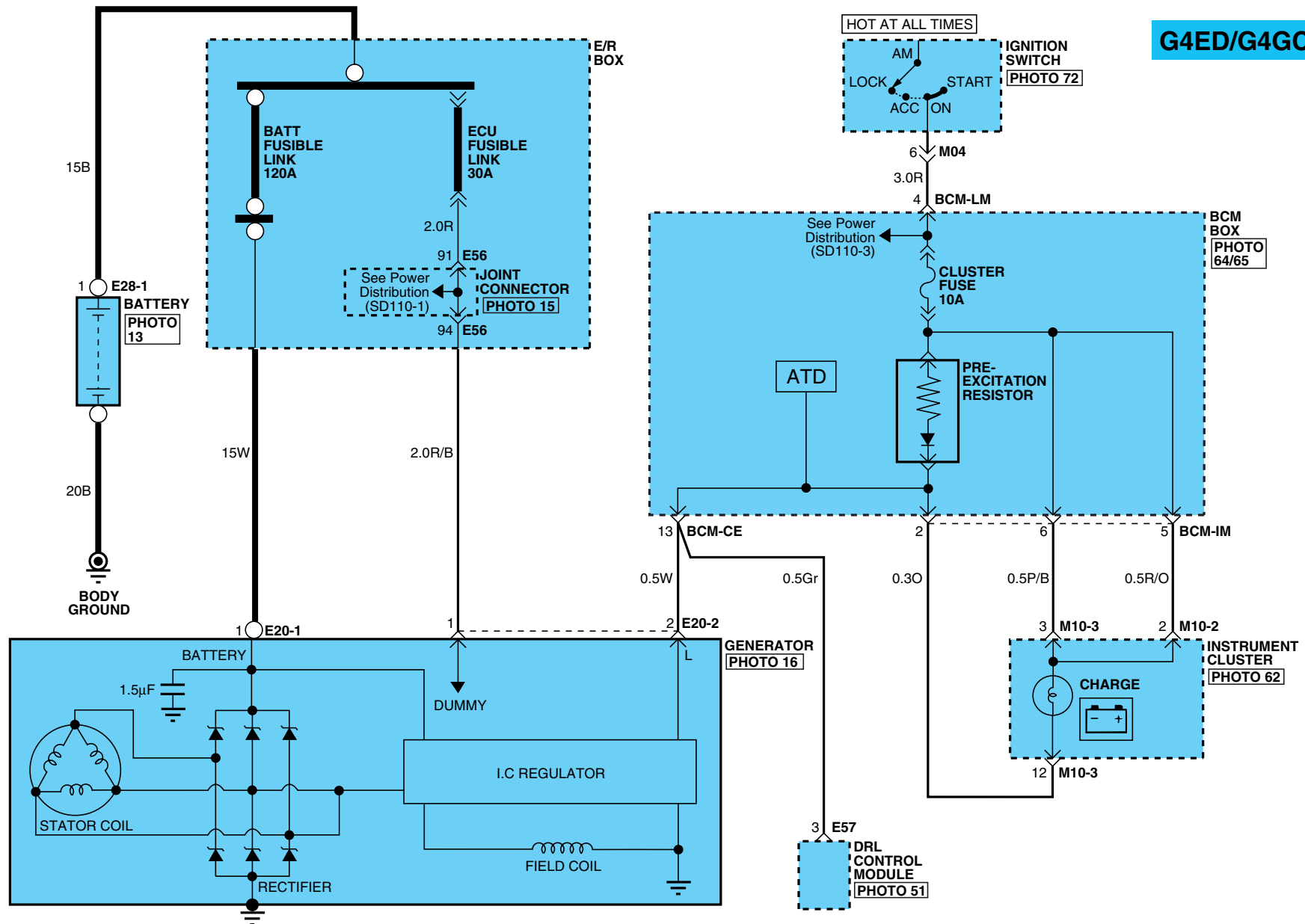

CHARGING SYSTEM

CHARGING SYSTEM (2)



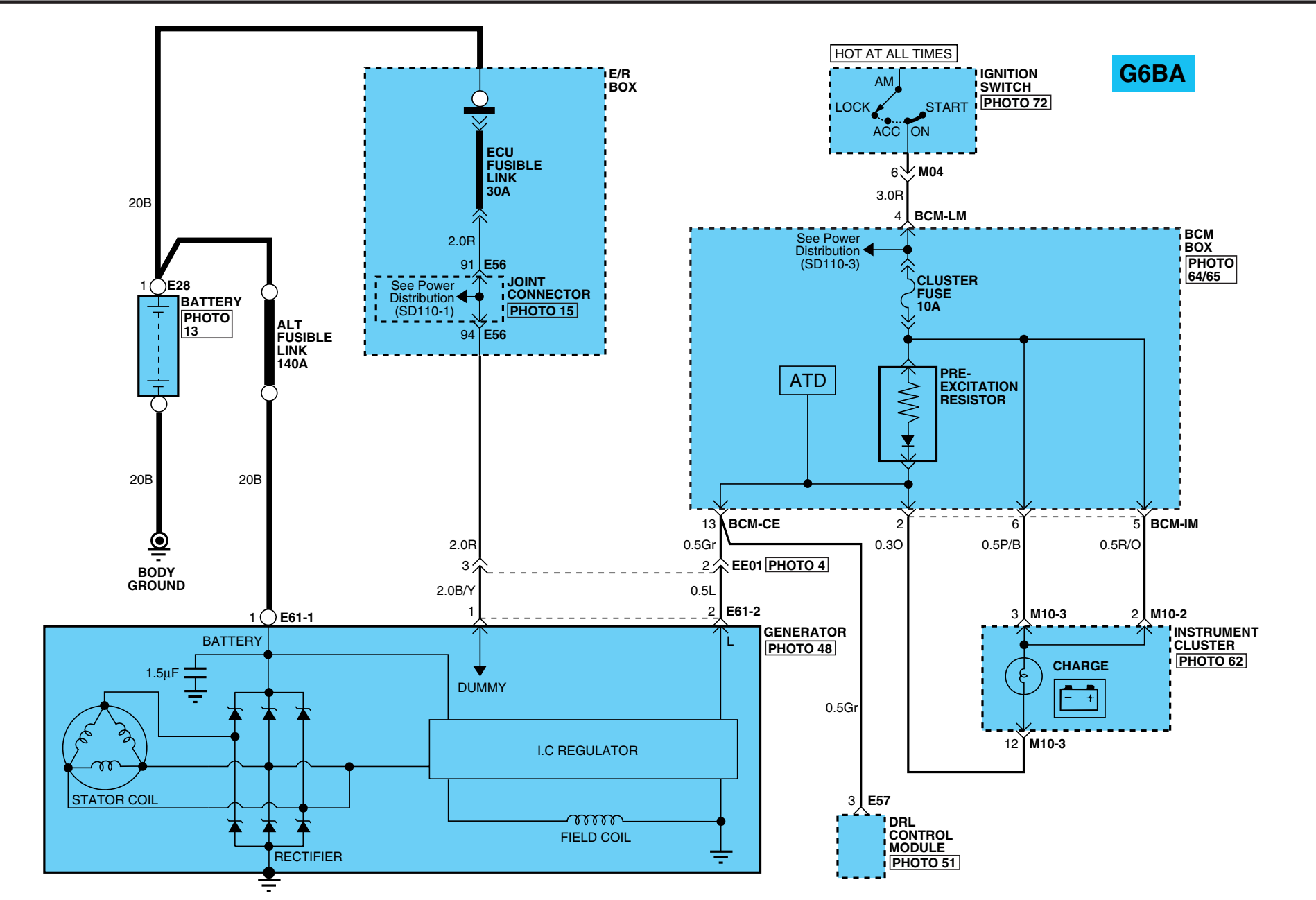

SD373-2

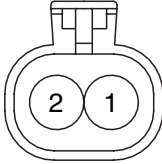

CHARGING SYSTEM

CHARGING SYSTEM (3)

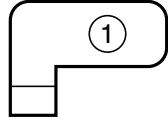
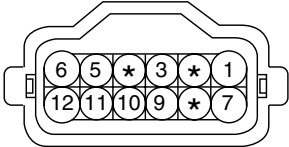
SD373-3

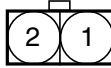
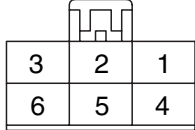
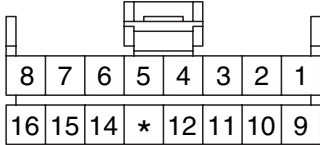
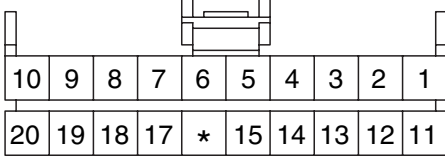
<p>E20-1</p>  <p>CR01F002</p>	<p>E20-2</p>  <p>KET_58X_02F_B</p>	<p>E28</p>  <p>CR01F005</p>	<p>E28-1</p>  <p>CR01F051</p>
<p>E57</p>  <p>KET_1809WP_12F_Gr</p>	<p>E61-1</p>  <p>CR01F002</p>	<p>E61-2</p>  <p>CR02F002</p>	<p>M04</p>  <p>KUM_DSD_06F_W</p>
<p>M10-2</p>  <p>AMP_040M1_16F_B</p>	<p>M10-3</p>  <p>AMP_040M1_20F_B</p>	<p>BLANK</p>	<p>BLANK</p>

CHARGING SYSTEM

CHARGING SYSTEM (4)

SD373-4

MEMO

VEHICLE SPEED SYSTEM (1)

SD436-1

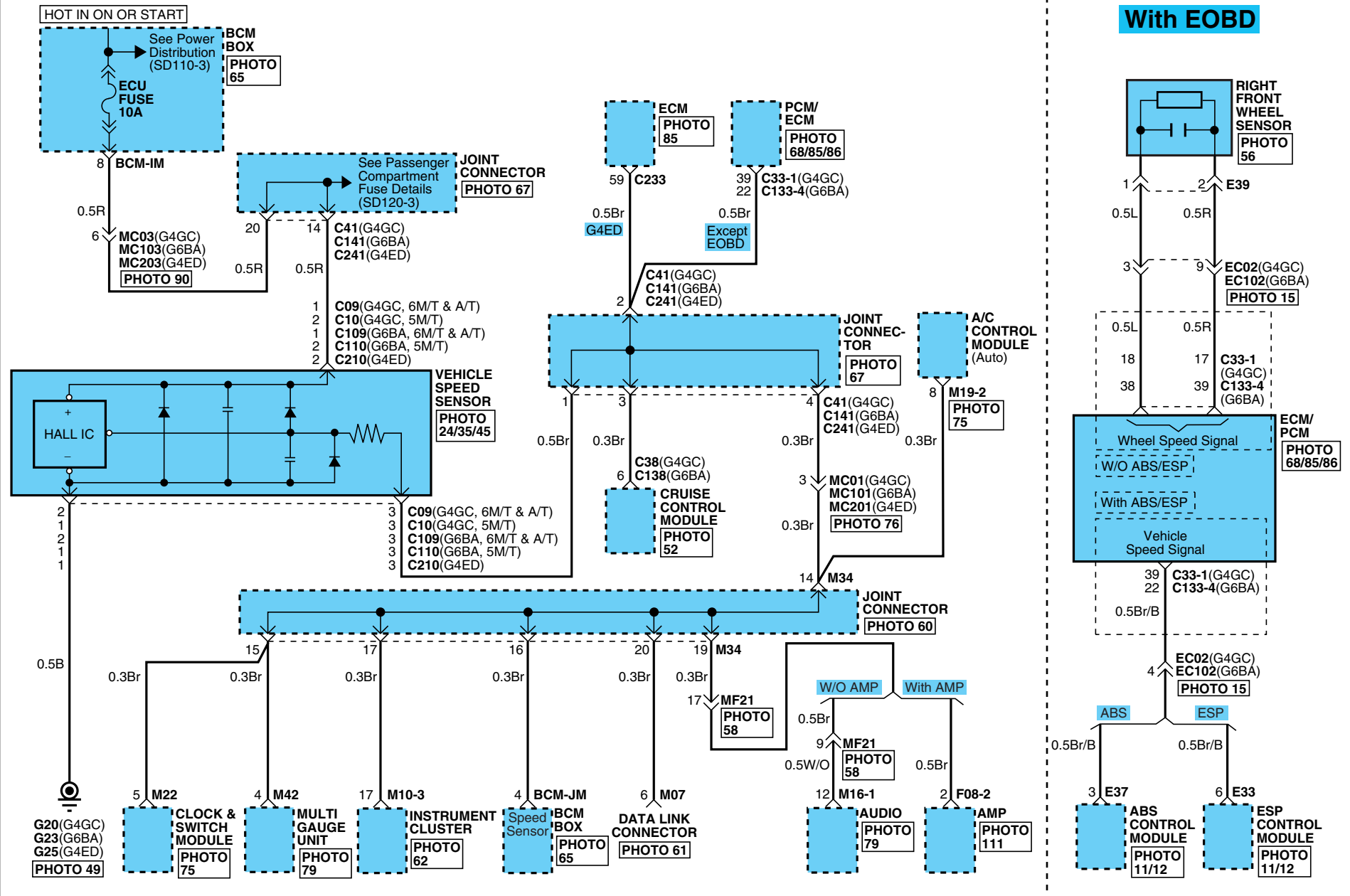

VEHICLE SPEED SYSTEM

VEHICLE SPEED SYSTEM (2)

SD436-2

C09/C10/C109/C110/C210

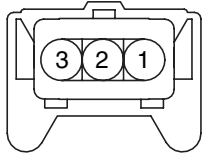

AMP_JPT_03F_B_S1

C33-1

6	7	8	9	10	11	*	*	14	*	*	17	18	*	*	21	22	23	24	5	4
*	26	27	*	29	30	31	32	*	*	*	*	37	38	39	*	*	42	43	3	
44	45	*	47	48	*	50	51	52	*	54	55	56	*	58	59	60	61	62		
*	64	65	66	67	68	69	70	*	72	73	*	75	76	77	78	*	80	81	2	1

KET_ECU_81F_B_BOSCH

C38/C138

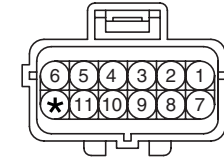

AMP_EJWP_12F_B

C133-4

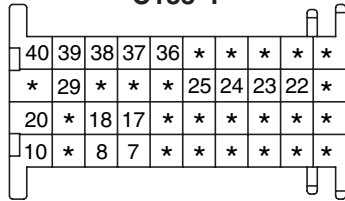

AMP_ECU_40F_B_134P

C233

6	7	8	*	*	11	12	13	14	15	16	17	18	19	20	*	*	*	24	5	*
*	26	27	28	29	*	31	32	33	34	35	36	37	*	39	*	*	42	*	3	
44	45	46	47	48	49	50	51	52	53	*	55	*	57	*	59	60	61	*		
63	*	*	*	*	68	69	70	71	*	73	74	75	*	*	*	79	80	*	2	*

KET_ECU_81F_B_BOSCH

E39

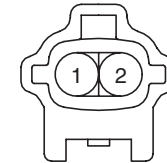

KET_090IWP_02M_Gr

E33

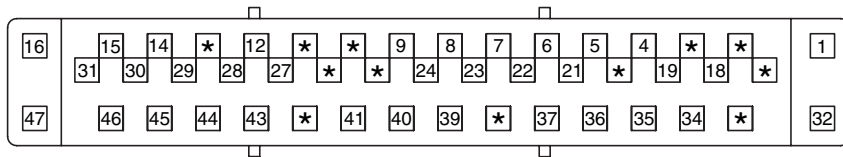

AMP_ESP_47F_L_UNIT

E37

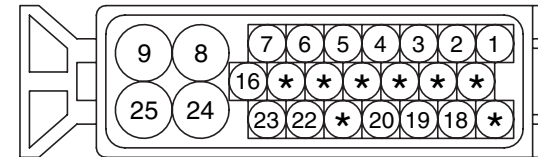

AMP_ABSWP_25F_B_GER

F08-2

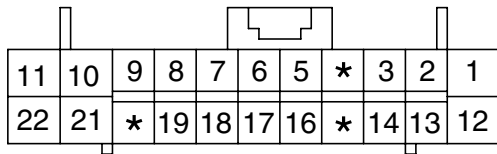

AMP_0407_22F_W_HD

M07

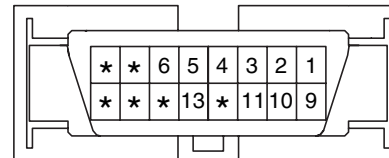

MLX_OBDII_16F_B_SIN

M10-3

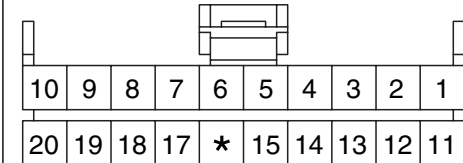

AMP_040M1_20F_B

M16-1

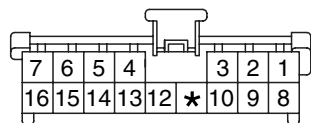

KUM_AR_16F_W

M19-2

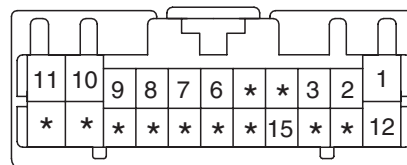

KET_0407_22F_W

M22

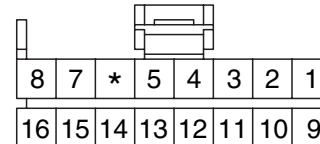

AMP_040M1_16F_B

M42

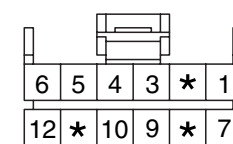

AMP_040M1_12F_B

AUTOMATIC TRANSAXLE CONTROL SYSTEM (G4GC) (1)

SD450-1

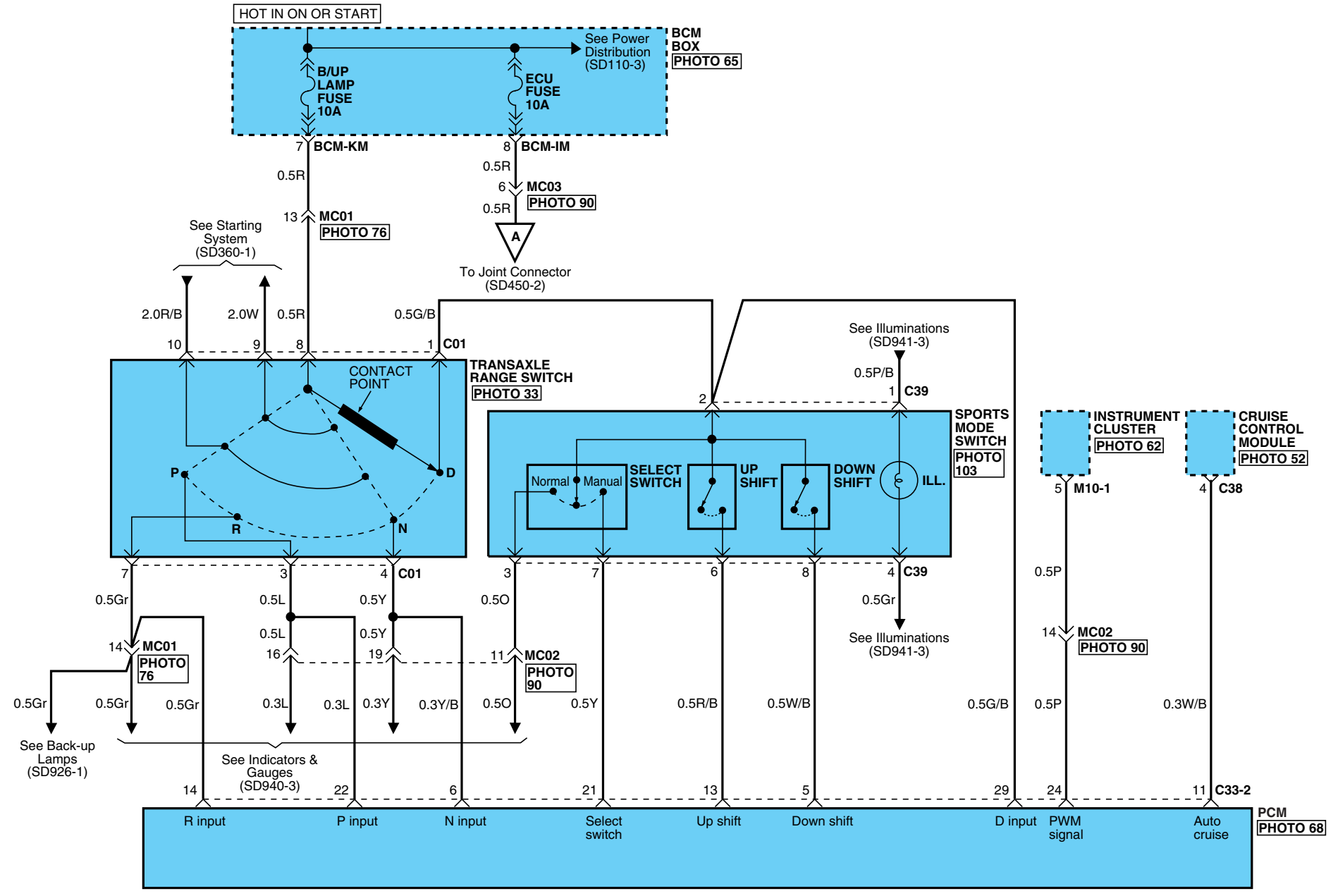

AUTOMATIC TRANSAXLE CONTROL SYSTEM

AUTOMATIC TRANSAXLE CONTROL SYSTEM (G4GC) (2)

SD450-2

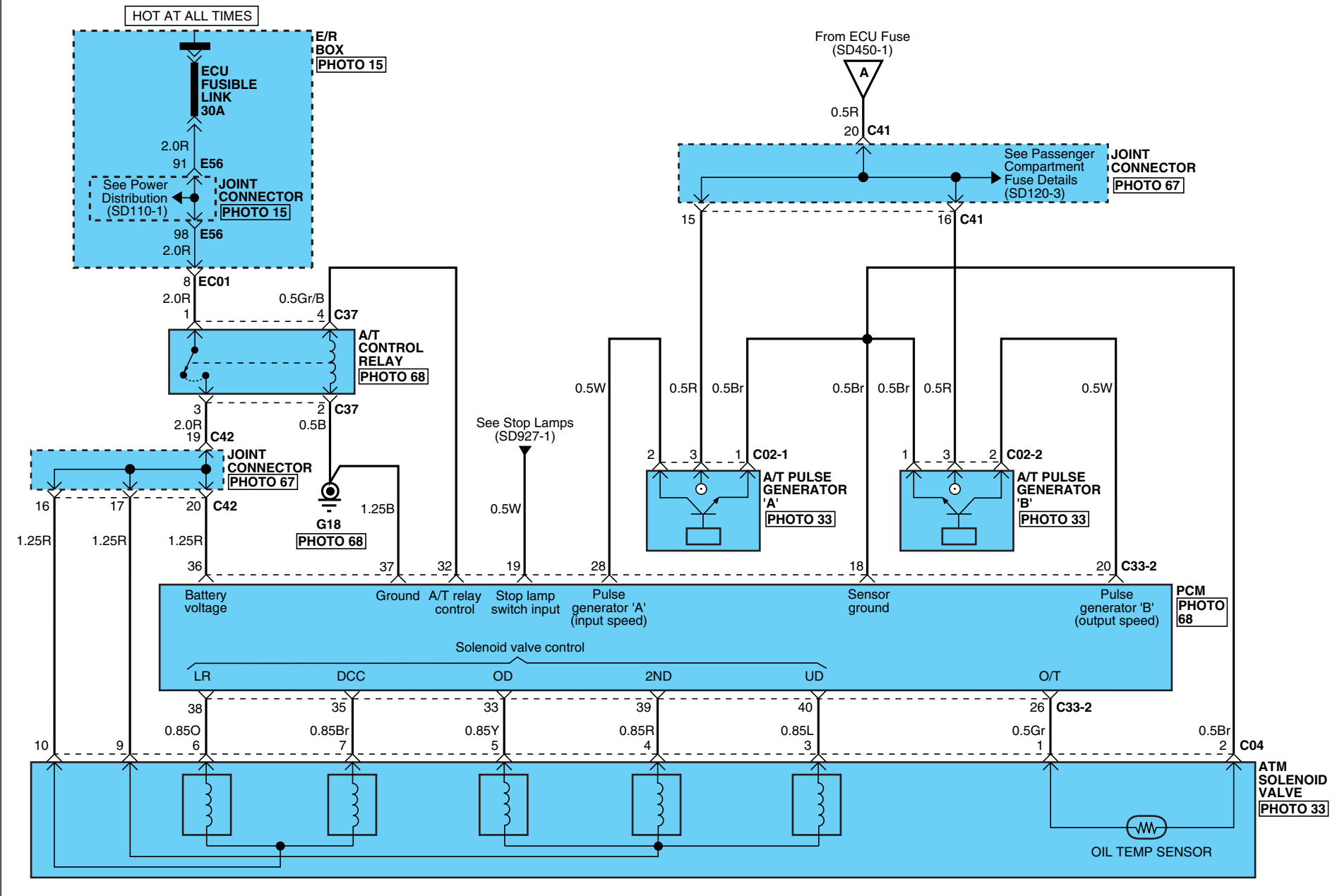

AUTOMATIC TRANSAXLE CONTROL SYSTEM

AUTOMATIC TRANSAXLE CONTROL SYSTEM (G4GC) (3)

SD450-3

C01



KET_SSD_10F_B_A

C02-1

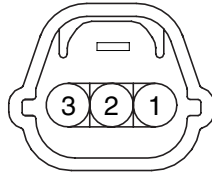

KET_SSD_03F_B_A

C02-2

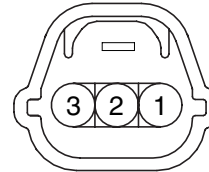

KET_SSD_03F_Gr_B

C04

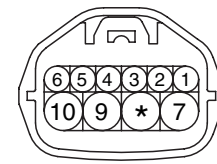

KET_SSD_10F_Gr_B

C33-2

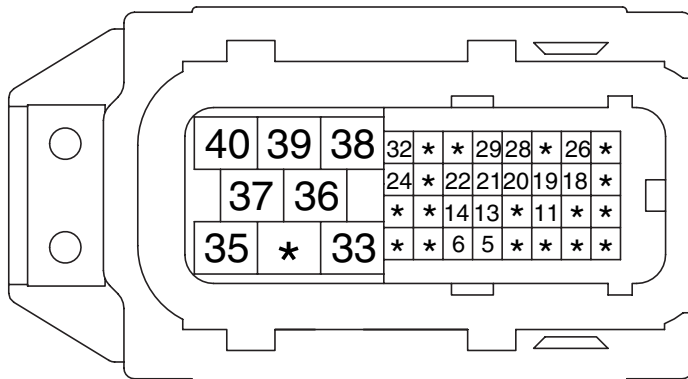

KET_ECU_40F_B

C37

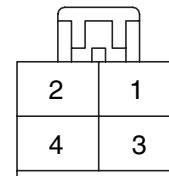

KUM_DSD_04F_B

C38

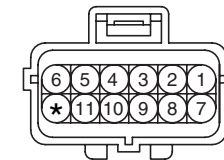

AMP_EJWP_12F_B

C39

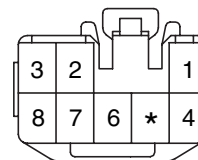

KET_090II_08F_W

M10-1

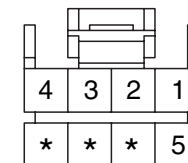

AMP_040M1_08F_B

AUTOMATIC TRANSAXLE CONTROL SYSTEM

AUTOMATIC TRANSAXLE CONTROL SYSTEM (G4GC) (4)

SD450-4

MEMO

AUTOMATIC TRANSAXLE CONTROL SYSTEM (G6BA) (1)

SD450-5

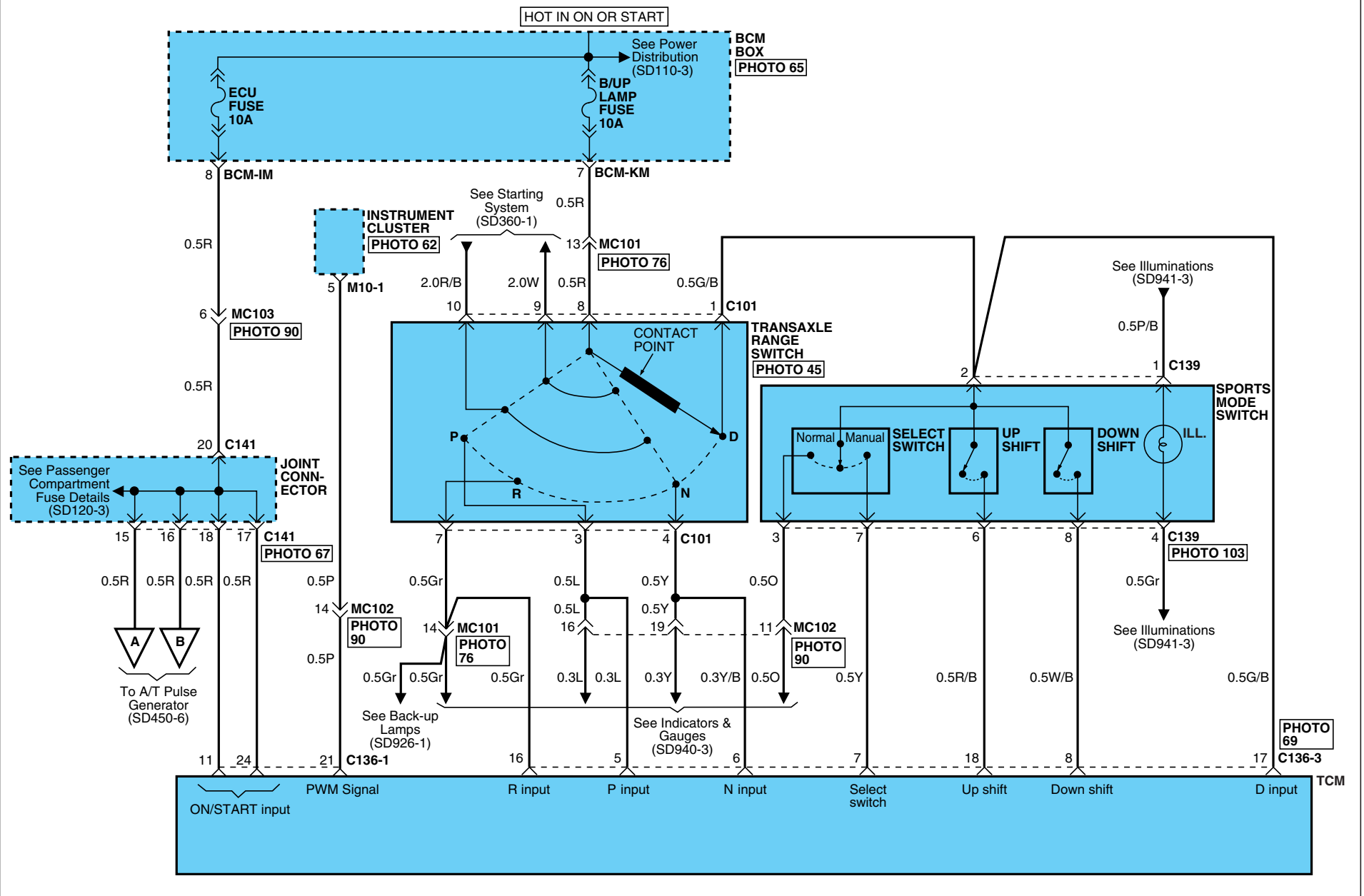

AUTOMATIC TRANSAXLE CONTROL SYSTEM

AUTOMATIC TRANSAXLE CONTROL SYSTEM (G6BA) (2)

SD450-6

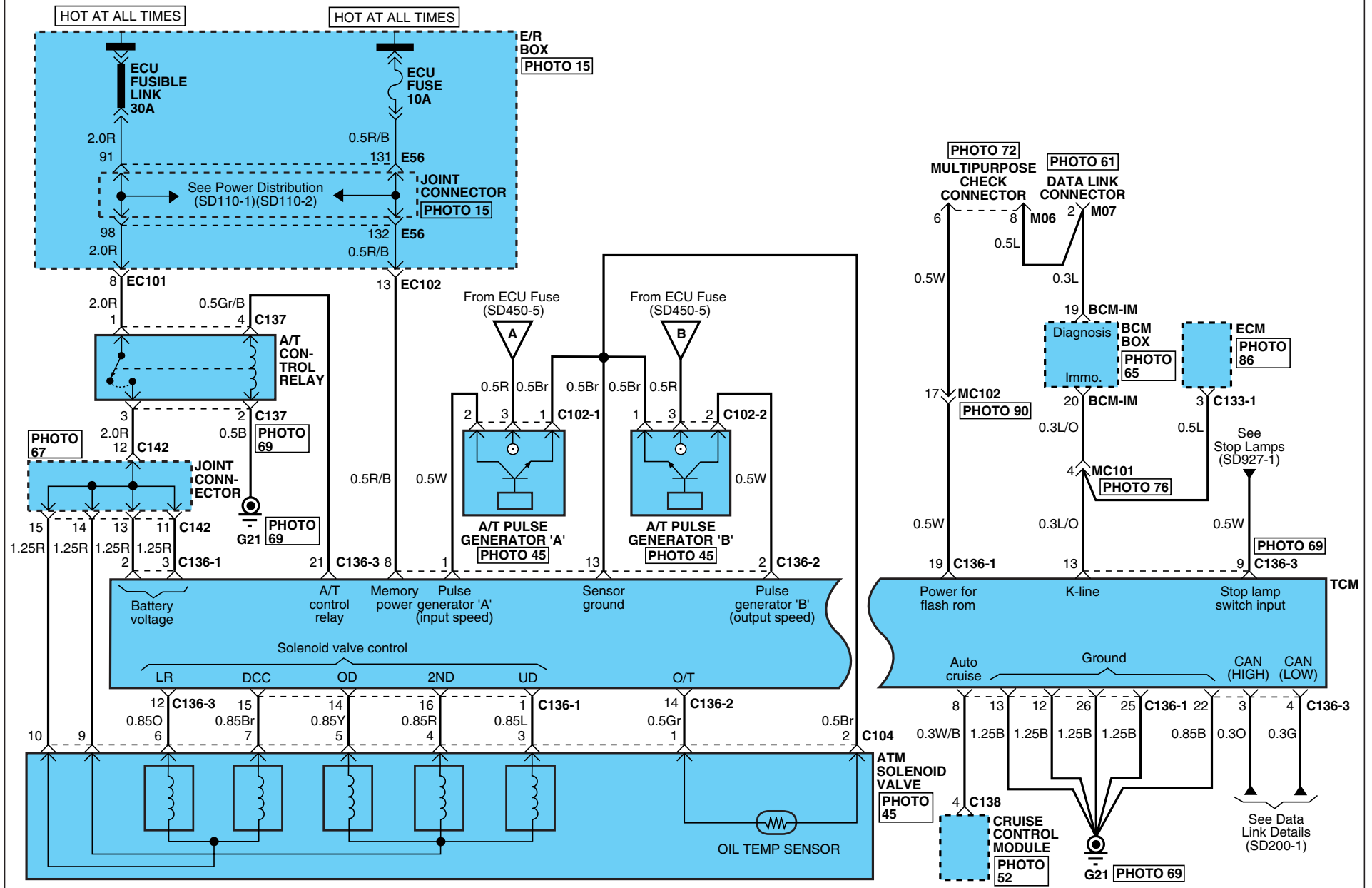

AUTOMATIC TRANSAXLE CONTROL SYSTEM

AUTOMATIC TRANSAXLE CONTROL SYSTEM (G6BA) (3)

SD450-7

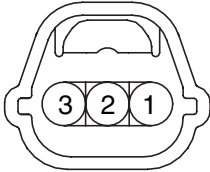
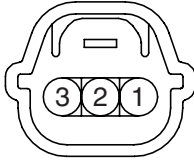
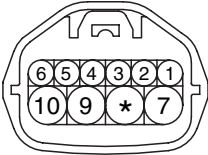
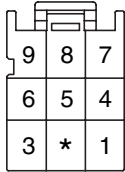
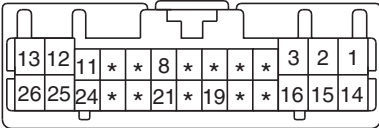
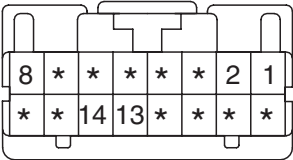
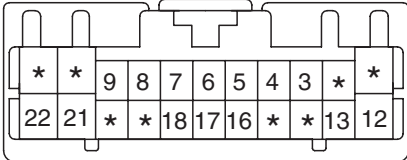
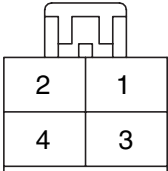
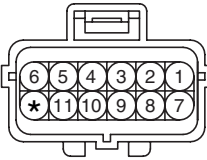
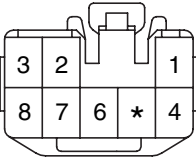
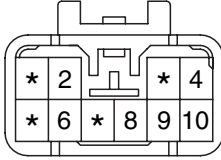
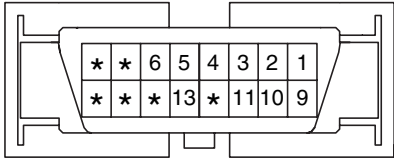
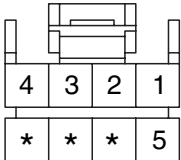
<p>C101</p>  <p>KET_SSD_10F_B_A</p>	<p>C102-1</p>  <p>KET_SSD_03F_B_A</p>	<p>C102-2</p>  <p>KET_SSD_03F_Gr_B</p>	<p>C104</p>  <p>KET_SSD_10F_Gr_B</p>
<p>C133-1</p>  <p>AMP_ECU_09F_B_134P</p>	<p>C136-1</p>  <p>KET_0407_26F_W</p>	<p>C136-2</p>  <p>KET_0407_16F_W</p>	<p>C136-3</p>  <p>KET_0407_22F_W</p>
<p>C137</p>  <p>KUM_DSD_04F_B</p>	<p>C138</p>  <p>AMP_EJWP_12F_B</p>	<p>C139</p>  <p>KET_090II_08F_W</p>	<p>M06</p>  <p>KET_090II_10M_W</p>
<p>M07</p>  <p>MLX_OBDII_16F_B_SIN</p>	<p>M10-1</p>  <p>AMP_040M1_08F_B</p>	<p>BLANK</p>	<p>BLANK</p>

AUTOMATIC TRANSAXLE CONTROL SYSTEM

AUTOMATIC TRANSAXLE CONTROL SYSTEM (G6BA) (4)

SD450-8

MEMO

AIR BAG SYSTEM (SRS) (1)

SD569-1

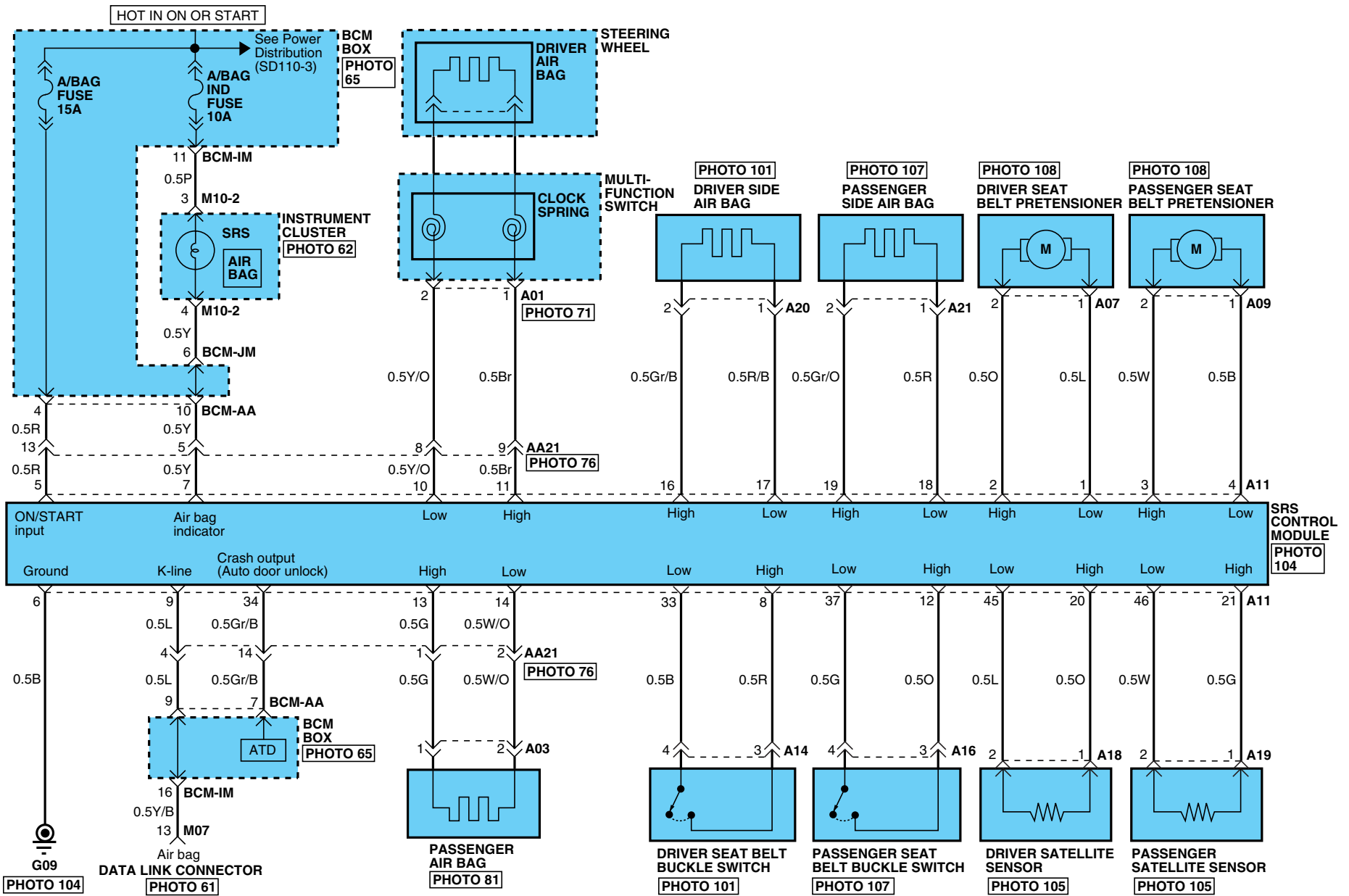

AIR BAG SYSTEM (SRS)

AIR BAG SYSTEM (SRS) (2)

SD569-2

A01

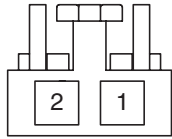

YAZ_DAB_02F_Y

A03

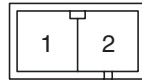

JAE_060_02M_Y_AB

A07

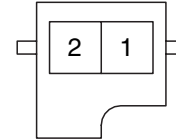

GNH_ABG_02F_Y

A09

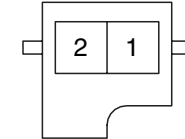

GNH_ABG_02F_Y

A11

1	2	3	4	5	6	7	8	9	10	11	12	13	14	*	16	17	18	19	20	21	*	*	*	*
*	*	*	*	*	*	*	33	34	*	*	37	*	*	*	*	*	*	*	45	46	*	*	*	*

AMP_ESPS_50F

A14

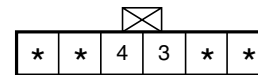

SIEMENS_SOCKET_06F_B

A16

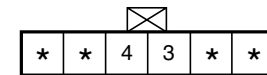

SIEMENS_SOCKET_06F_B

A18

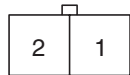

PKD_GK_02F_B

A19

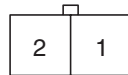

PKD_GK_02F_B

A20

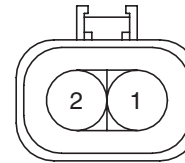

YAZ_040WP_02F_Y

A21

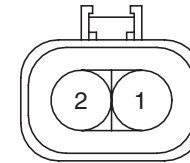

YAZ_040WP_02F_Y

M07

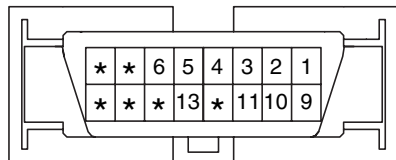

MLX_OBDII_16F_B_SIN

M10-2

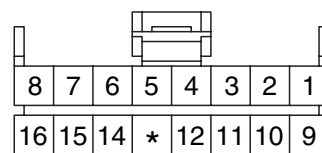

AMP_040M1_16F_B

BLANK

BLANK

ANTI-LOCK BRAKE SYSTEM (ABS)

E5E50F84

ANTI-LOCK BRAKE SYSTEM (ABS) (1)

SD587-1

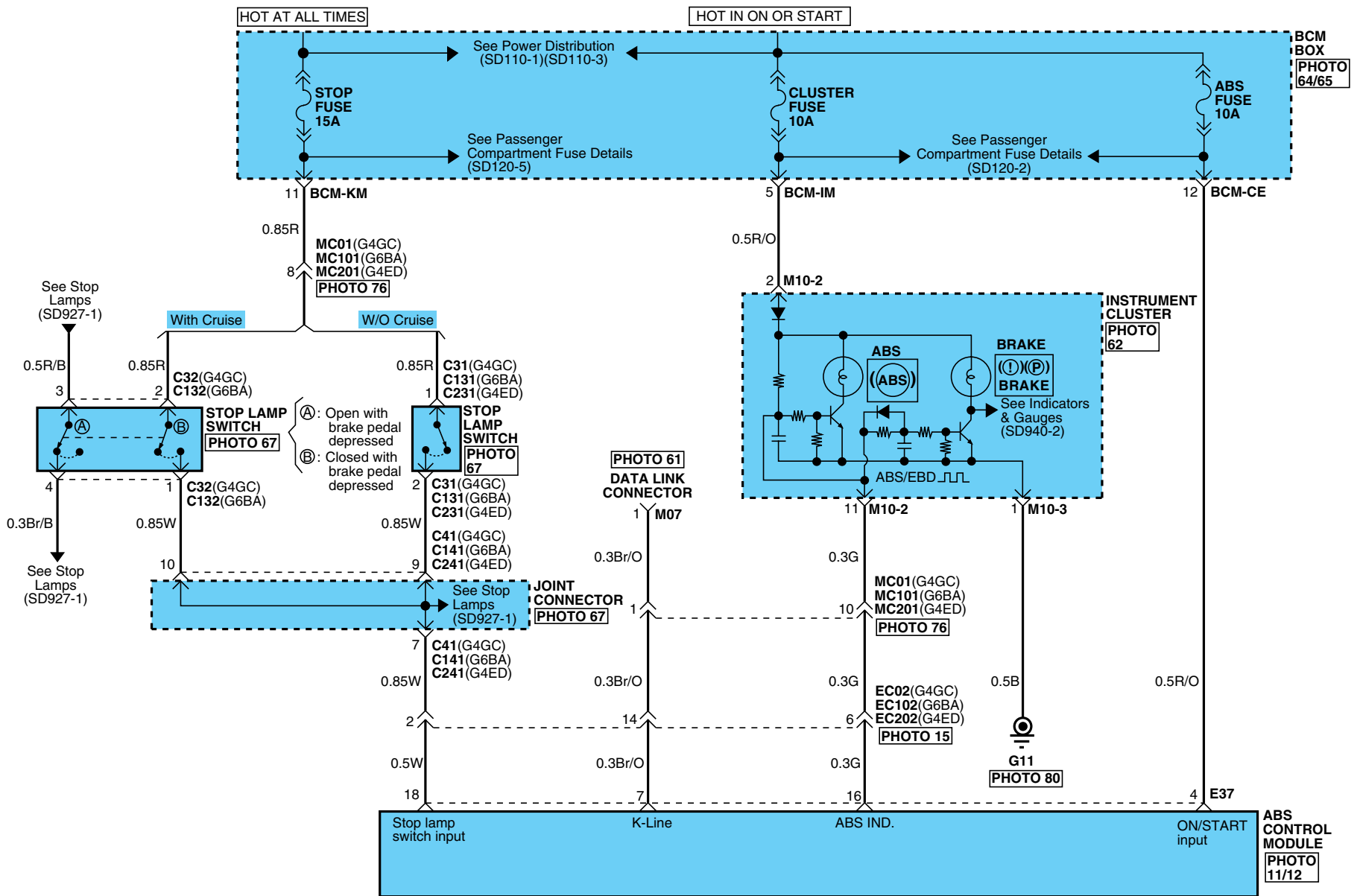

ANTI-LOCK BRAKE SYSTEM (ABS)

ANTI-LOCK BRAKE SYSTEM (ABS) (2)

SD587-2

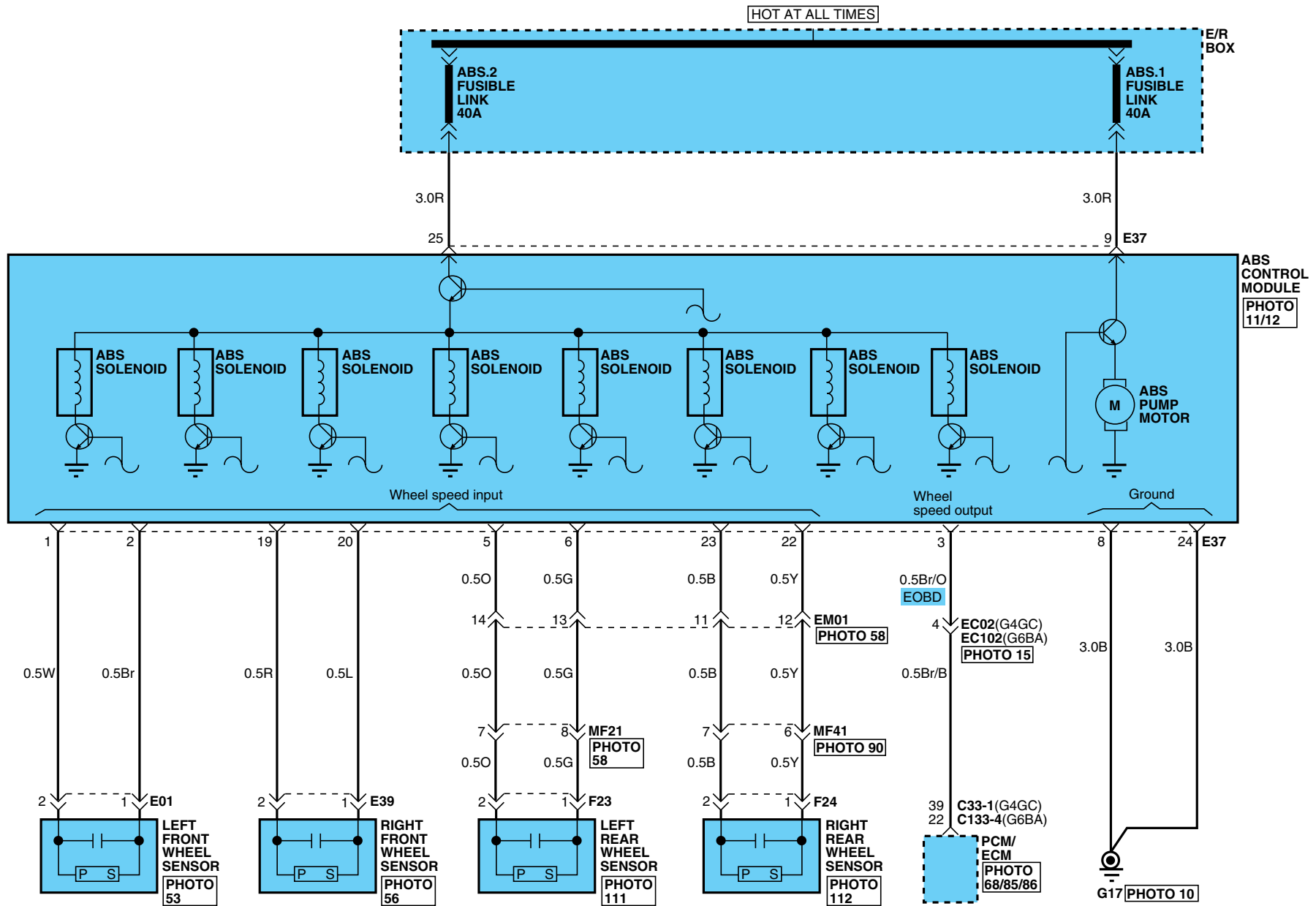

ANTI-LOCK BRAKE SYSTEM (ABS)

ANTI-LOCK BRAKE SYSTEM (ABS) (3)

SD587-3

C31/C131/C231

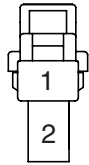

KET_250DL_02F_W

C32/C132

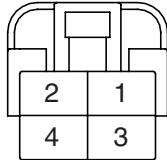

KET_250DL_04F_W

C33-1

6	7	8	9	10	11	*	*	14	*	*	17	18	*	*	21	22	23	24	5	4
*	26	27	*	29	30	31	32	*	*	*	*	37	38	39	*	*	42	43	3	
44	45	*	47	48	*	50	51	52	*	54	55	56	*	58	59	60	61	62		
*	64	65	66	67	68	69	70	*	72	73	*	75	76	77	78	*	80	81	2	1

KET_ECU_81F_B_BOSCH

C133-4

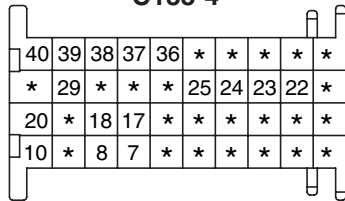

AMP_ECU_40F_B_134P

E01

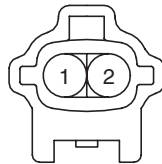

KET_090IWP_02M_Gr

E37

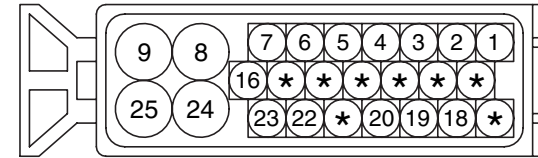

AMP_ABSWP_25F_B_GER

E39

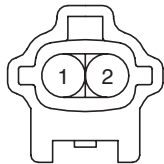

KET_090IWP_02M_Gr

F23

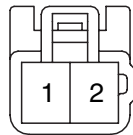

KET_090II_02M_W_R

F24

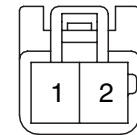

KET_090II_02M_W_R

M07

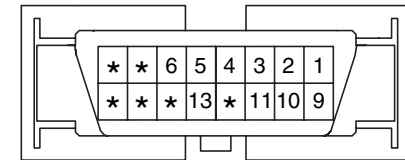

MLX_OBDII_16F_B_SIN

M10-2

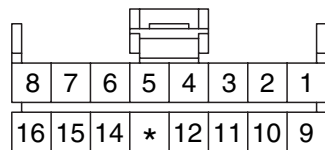

AMP_040M1_16F_B

M10-3

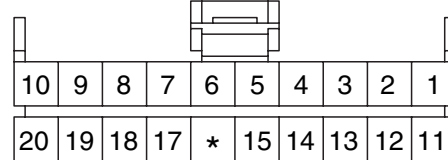

AMP_040M1_20F_B

BLANK

BLANK

ANTI-LOCK BRAKE SYSTEM (ABS)

ANTI-LOCK BRAKE SYSTEM (ABS) (4)

SD587-4

MEMO

ESP (ELECTRONIC STABILITY PROGRAM) SYSTEM (1)

SD589-1

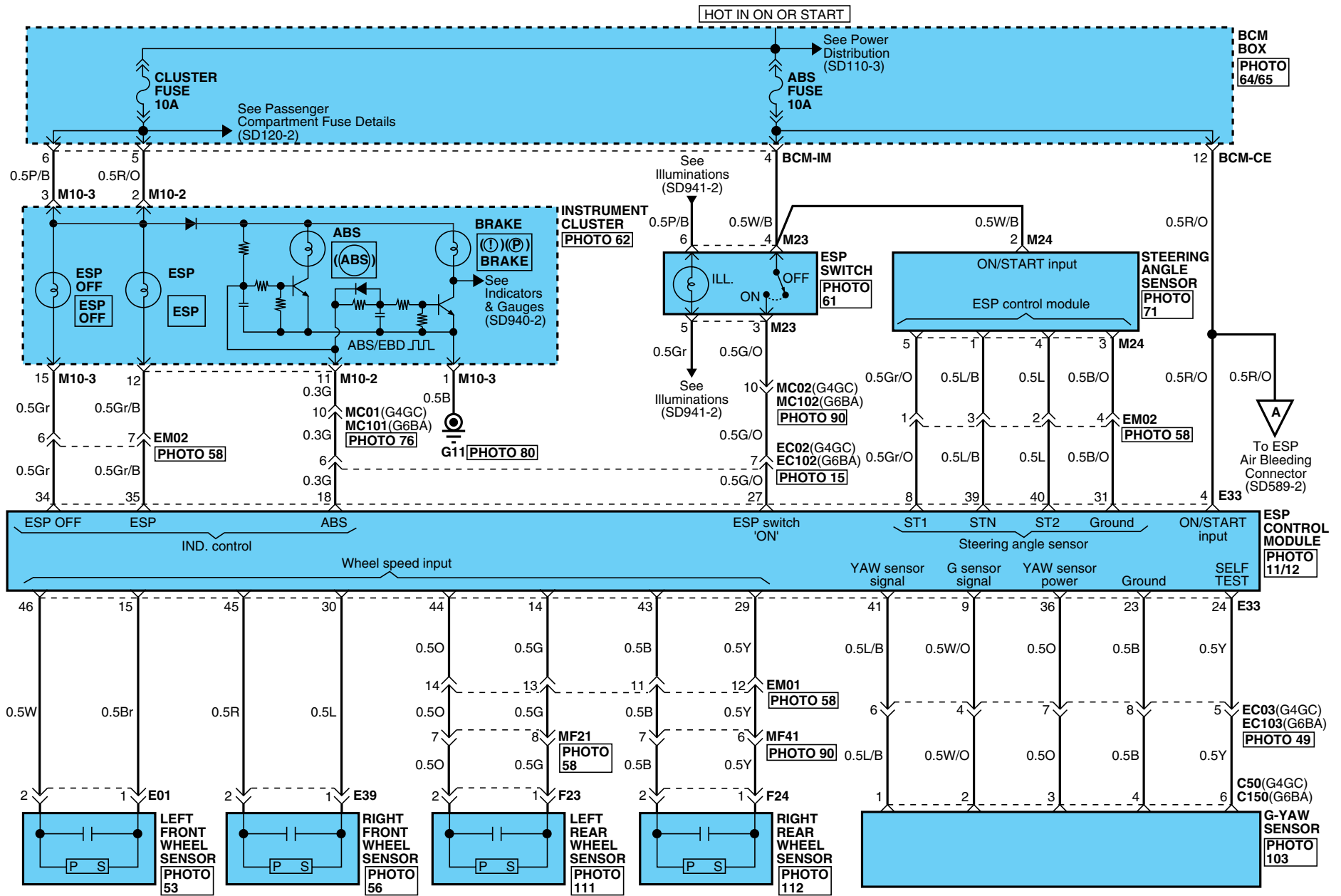

ESP (ELECTRONIC STABILITY PROGRAM) SYSTEM

ESP (ELECTRONIC STABILITY PROGRAM) SYSTEM (2)

SD589-2

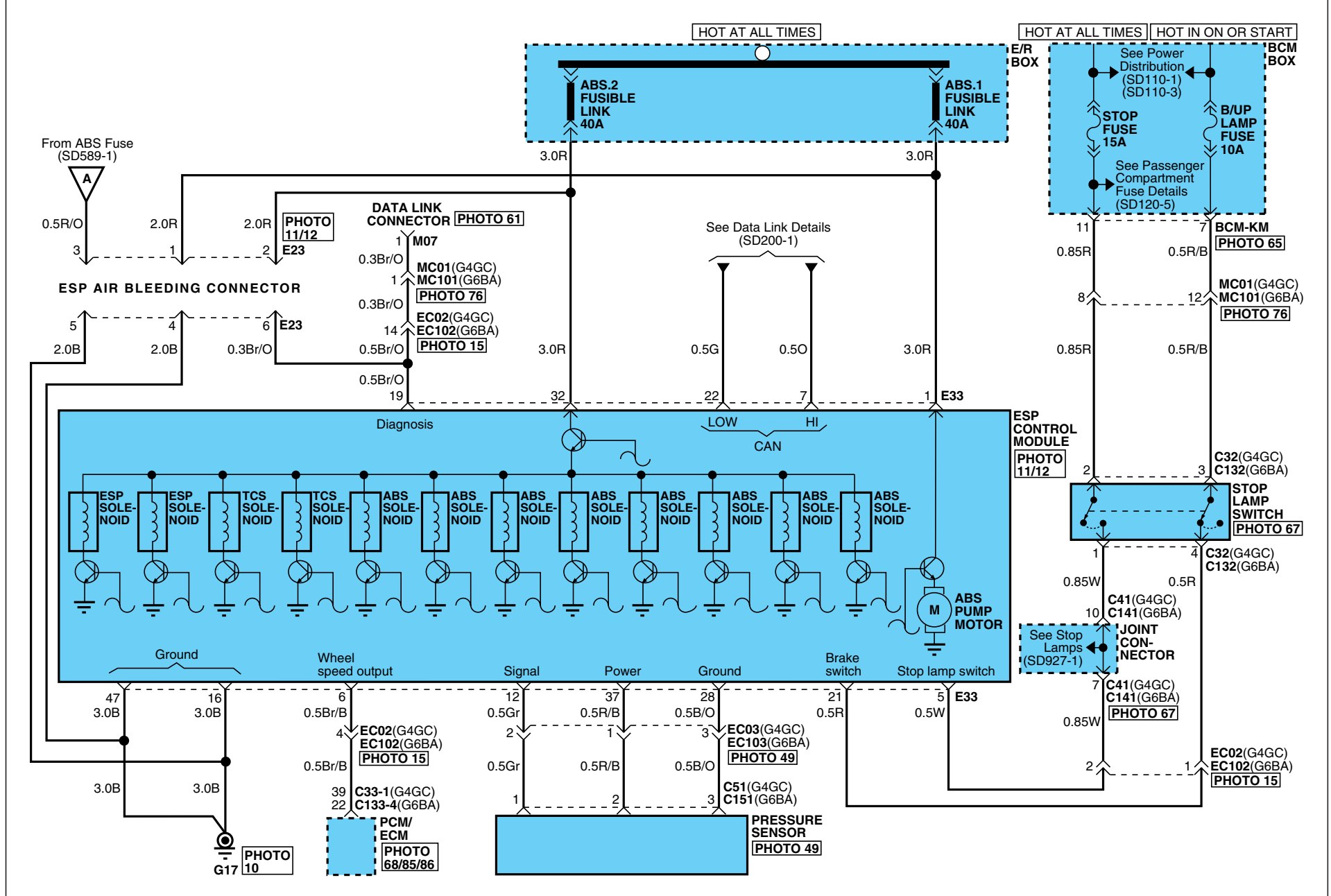

ESP (ELECTRONIC STABILITY PROGRAM) SYSTEM

ESP (ELECTRONIC STABILITY PROGRAM) SYSTEM (3)

SD589-3

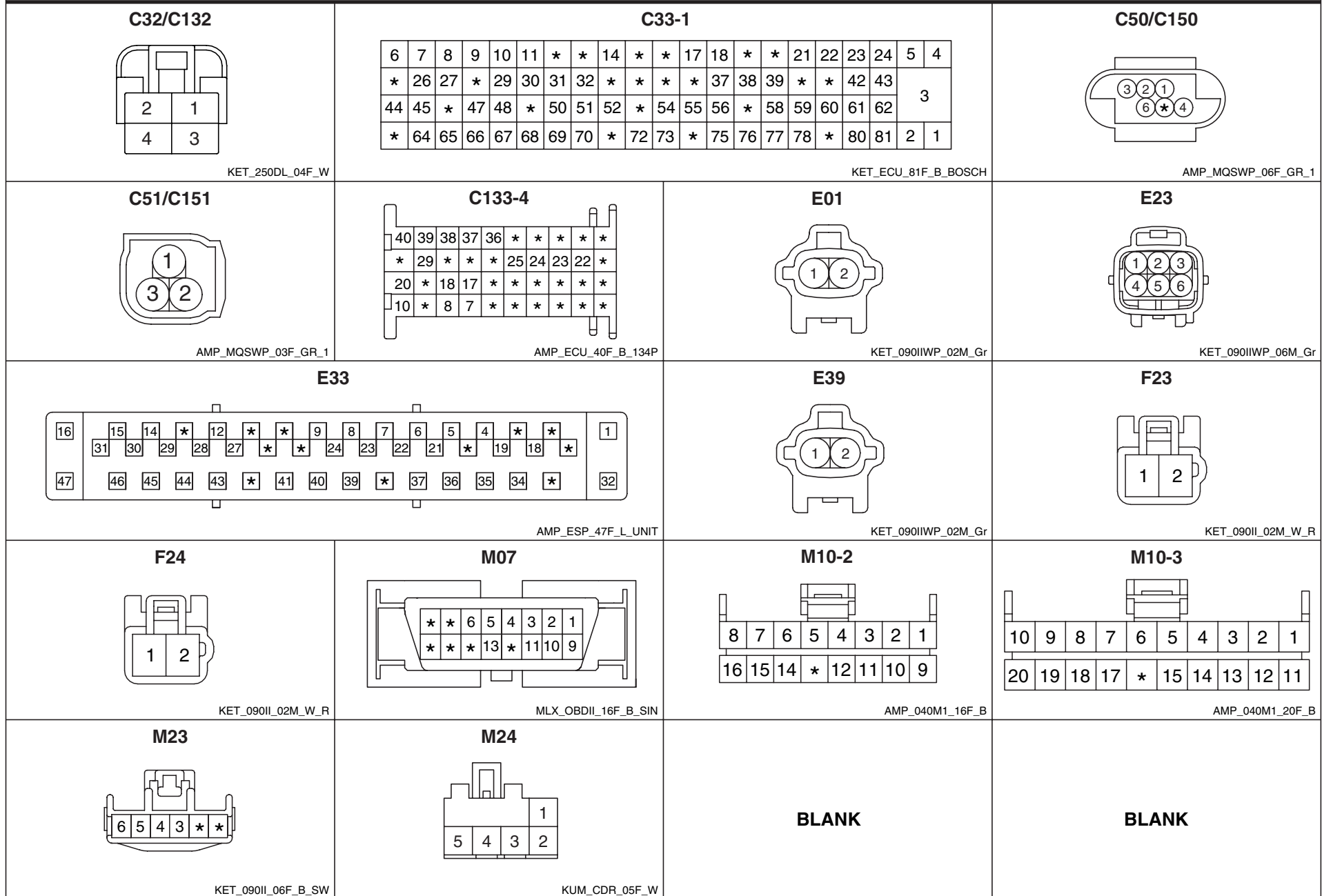

ESP (ELECTRONIC STABILITY PROGRAM) SYSTEM

ESP (ELECTRONIC STABILITY PROGRAM) SYSTEM (4)

SD589-4

MEMO

POWER DOOR LOCKS

POWER DOOR LOCKS (2)

SD813-2

D09



KET_SSD_06F_B

D09-1



KET_SSD_06F_B

D19



KET_SSD_06F_B

D19-1







KET_SSD_06F_B

KEYLESS ENTRY & BURGLAR ALARM SYSTEM

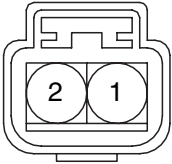
KEYLESS ENTRY & BURGLAR ALARM SYSTEM (2)

SD814-2

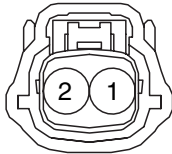
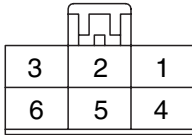
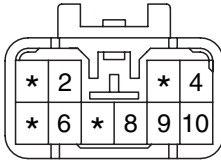
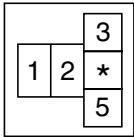
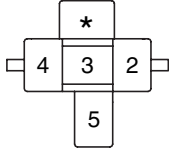
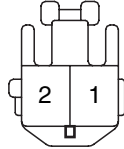
<p>C29/C129/C229</p>  <p>KUM_NMWP_02F_B</p>	<p>D09</p>  <p>KET_SSD_06F_B</p>	<p>D09-1</p>  <p>KET_SSD_06F_B</p>	<p>D19</p>  <p>KET_SSD_06F_B</p>
<p>D19-1</p>  <p>KET_SSD_06F_B</p>	<p>E17</p>  <p>MLX_HORN_02F_B_FILT</p>	<p>M04</p>  <p>KUM_DSD_06F_W</p>	<p>M06</p>  <p>KET_090II_10M_W</p>
<p>M39</p>  <p>KET_ISO_MICRO_RLY</p>	<p>M41</p>  <p>KET_250_05F_B_RLY</p>	<p>R03</p>  <p>KET_090II_02F_Gr_T</p>	<p>BLANK</p>

SUNROOF (1)

SD816-1

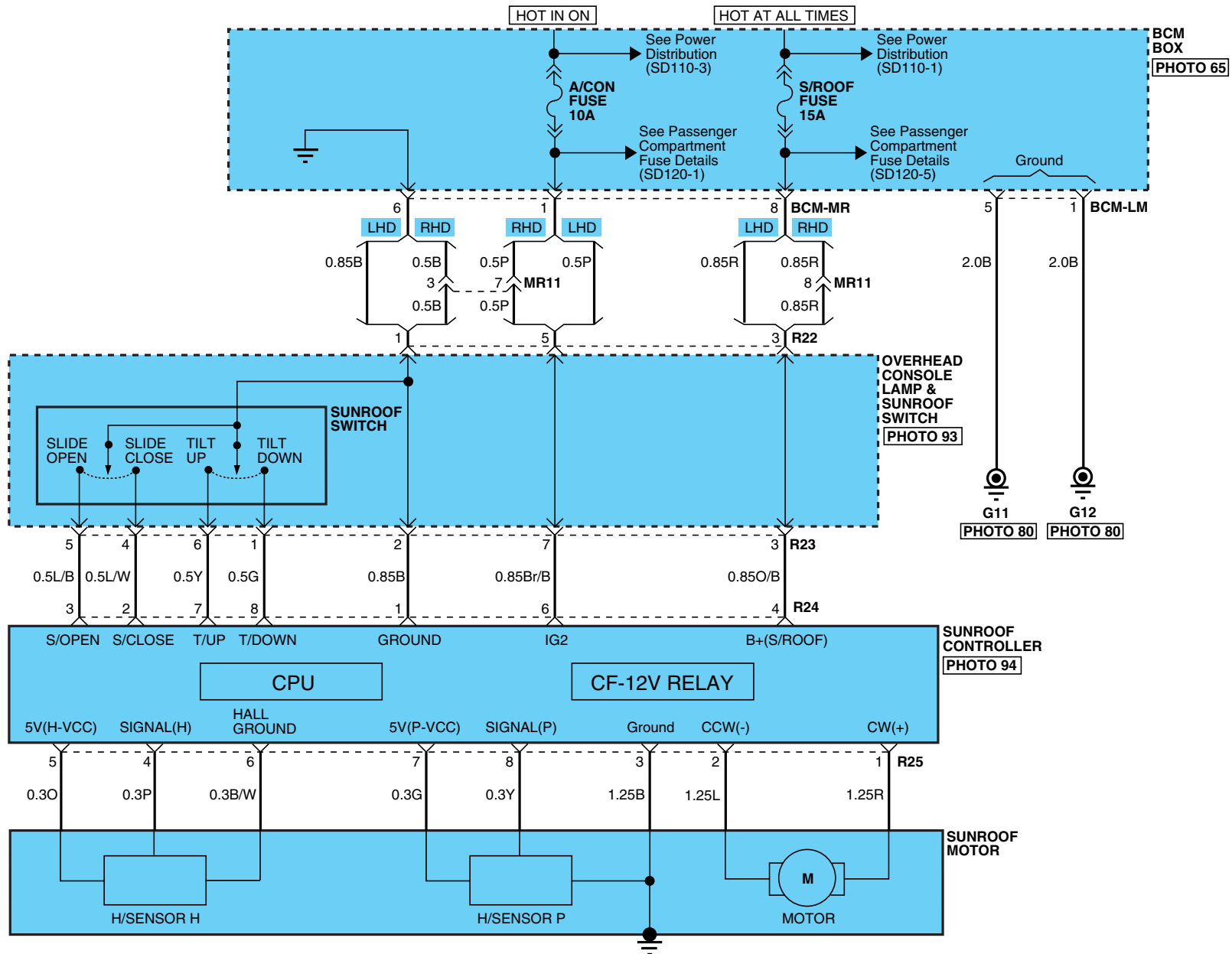

SUNROOF

SUNROOF (2)

SD816-2

R22

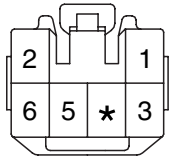

KET_090II_06F_W

R23

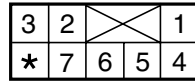

CR08F001

R24

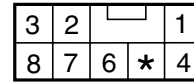

CR08F001

R25

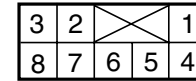

CR08F027

POWER WINDOWS (1)

SD824-1

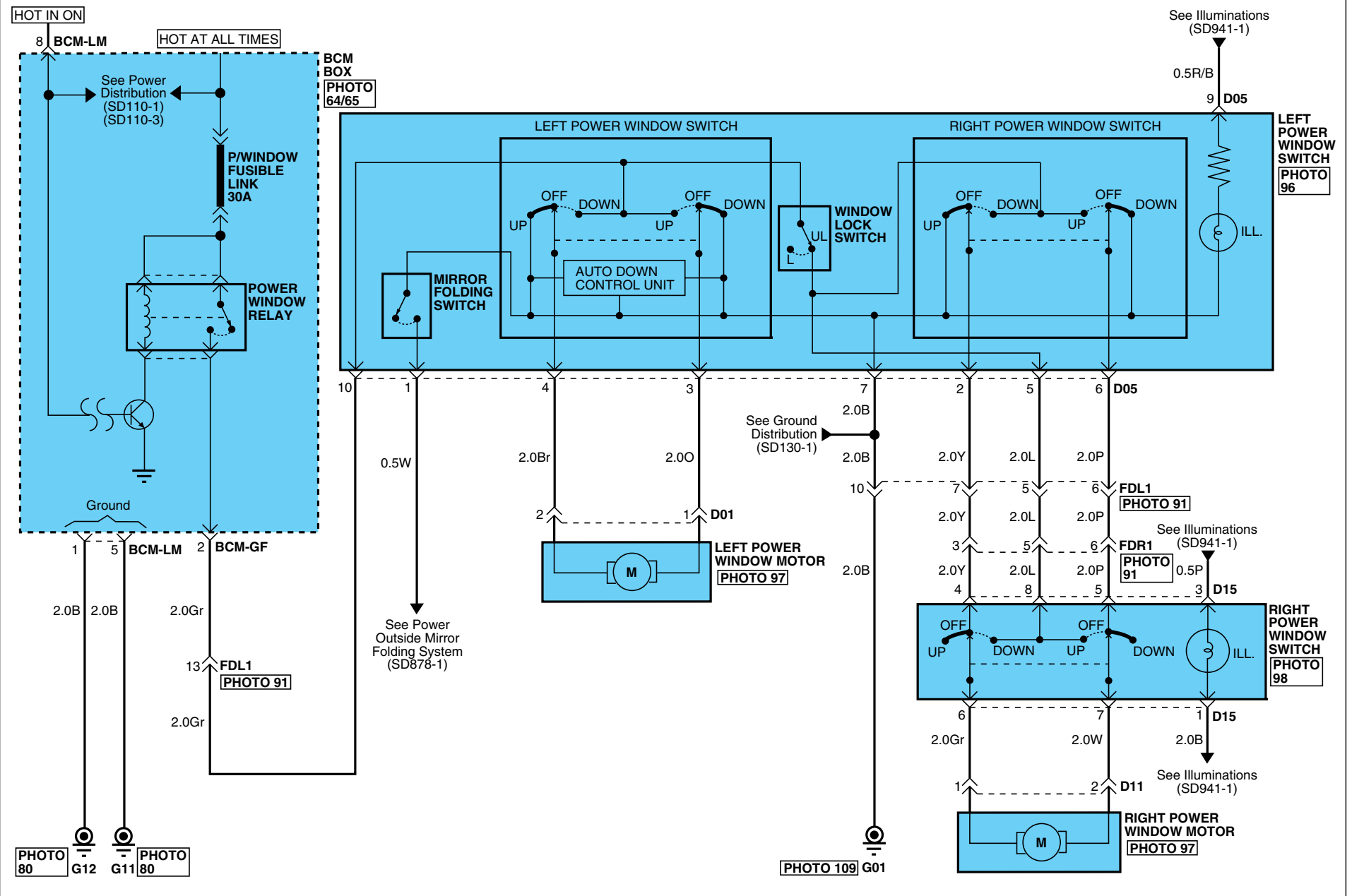

POWER WINDOWS

POWER WINDOWS (2)

SD824-2

D01

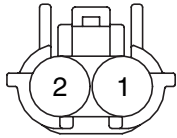

KET_SWP_02F_B

D05

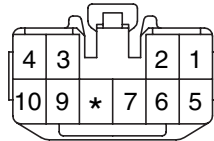

KET_090II_10F_W

D11

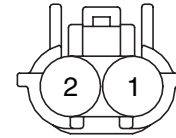

KET_SWP_02F_B

D15

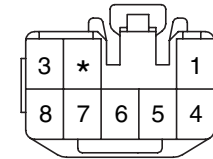

KET_090II_08F_W

CIGARETTE LIGHTER & TAIL GATE LID OPENER (1)

SD847-1

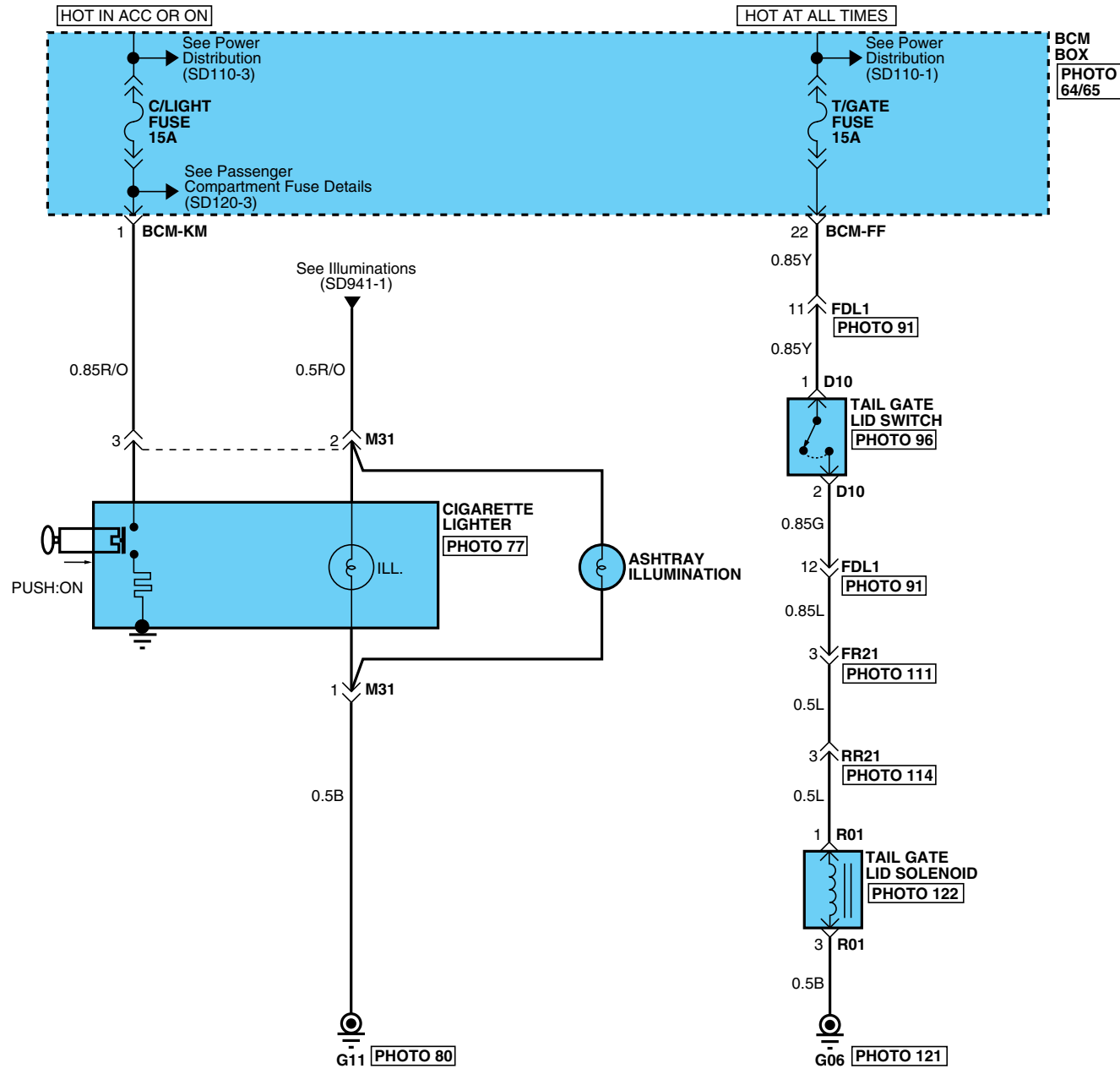

CIGARETTE LIGHTER & TAIL GATE LID OPENER

CIGARETTE LIGHTER & TAIL GATE LID OPENER (2)

SD847-2

D10

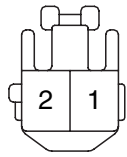

KET_090II_02F_W_L

M31

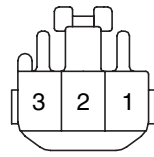

KET_090II_03F_W

R01

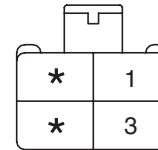

KET_250_04F_B

BLANK

ELECTRO CHROMIC MIRROR (1)

SD851-1

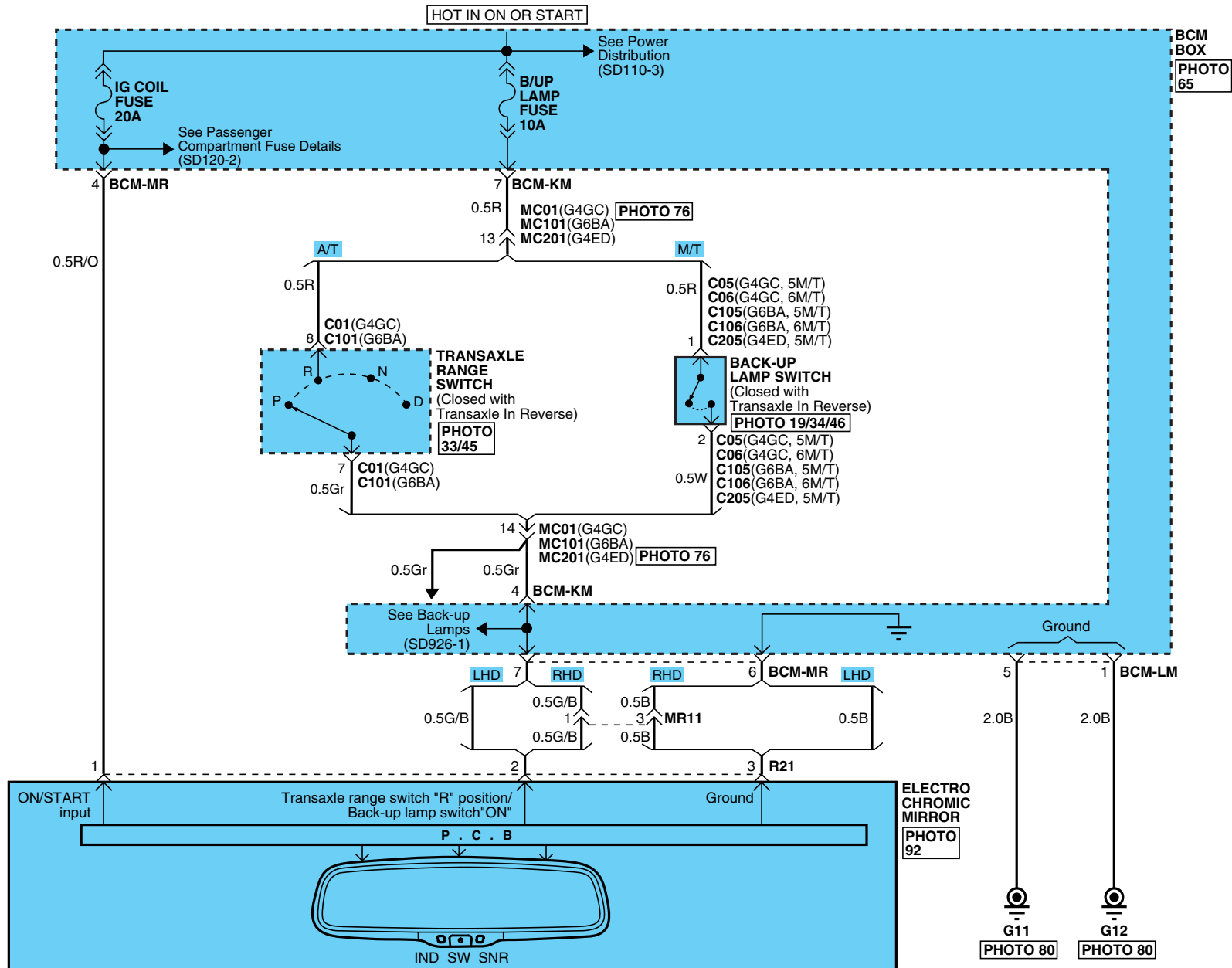

ELECTRO CHROMIC MIRROR

ELECTRO CHROMIC MIRROR (2)

SD851-2

C01



KET_SSD_10F_B_A

C05

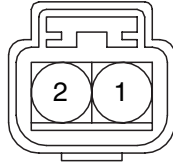

KUM_NMWP_02F_B

C06

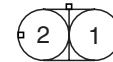

YAZ_91RVWP_02F_B

C101

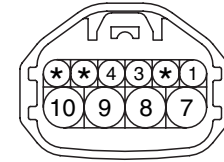

KET_SSD_10F_B_A

C105

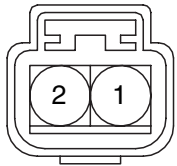

KUM_NMWP_02F_B

C106

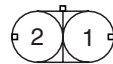

YAZ_91RVWP_02F_B

C205

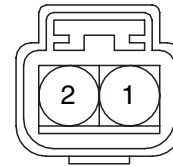

KUM_NMWP_02F_B

R21

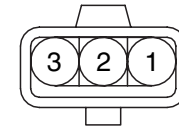

KET_TLCWP_03F_B

POWER OUTSIDE MIRRORS

POWER OUTSIDE MIRRORS (2)

SD876-2

RHD

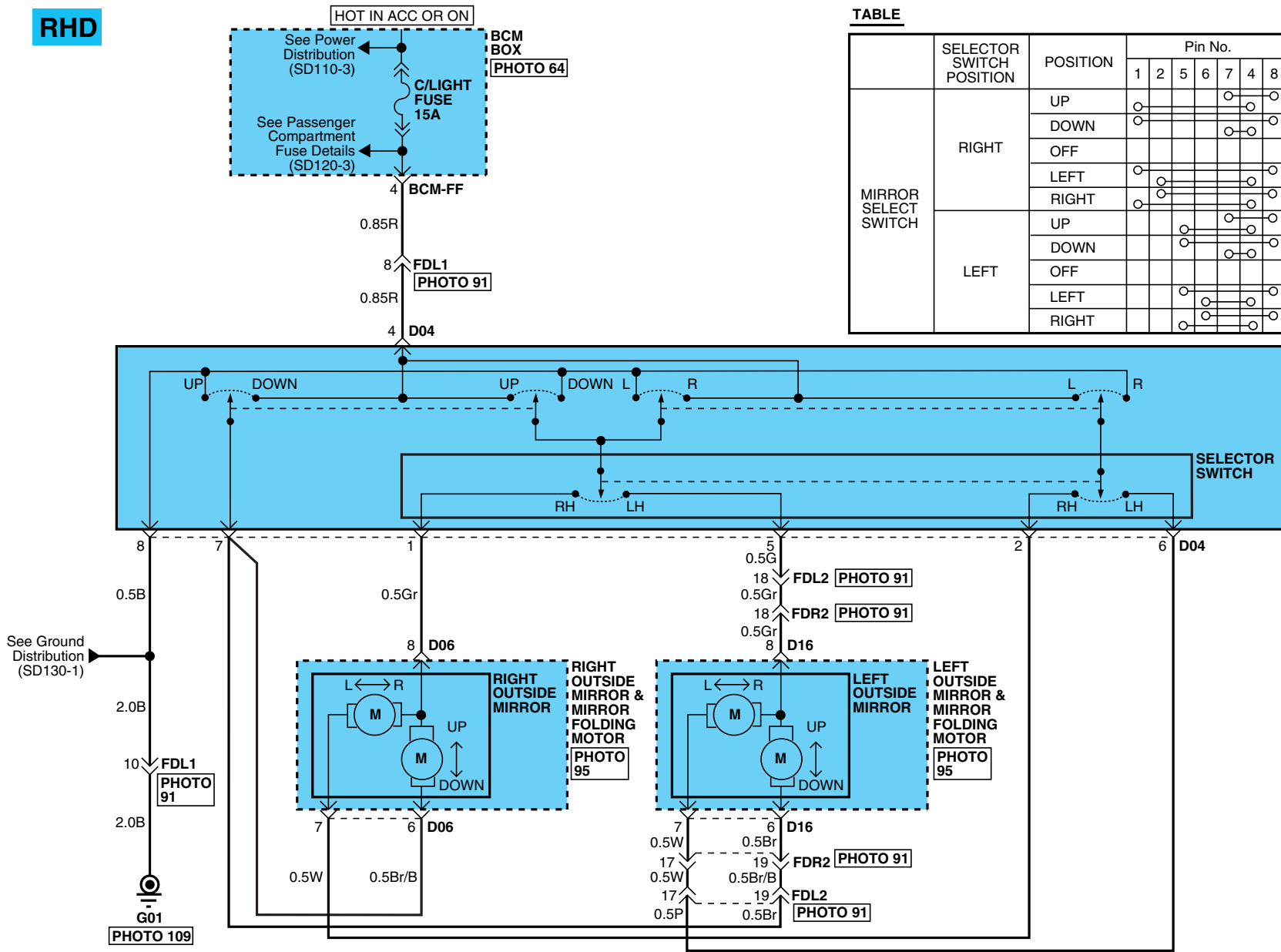

TABLE

	SELECTOR SWITCH POSITION	POSITION	Pin No.							
			1	2	5	6	7	4	8	
MIRROR SELECT SWITCH	RIGHT	UP	○				○	○		○
		DOWN	○							○
		OFF						○	○	
MIRROR SELECT SWITCH	LEFT	UP	○							○
		DOWN		○						○
		LEFT			○	○				
		RIGHT					○	○		

OUTSIDE MIRROR SWITCH
PHOTO 96

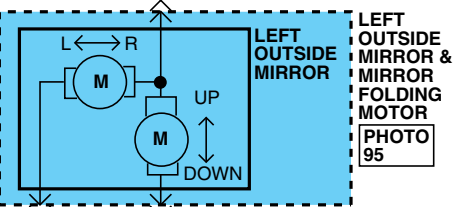
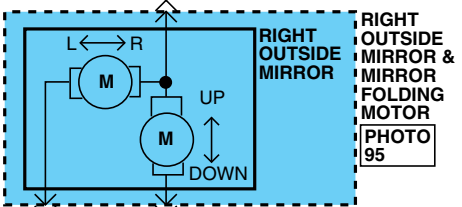

POWER OUTSIDE MIRRORS

POWER OUTSIDE MIRRORS (3)

SD876-3

D04

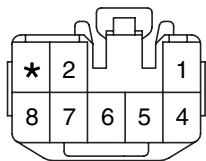

KET_090I1_08F_W

D06

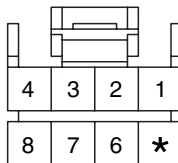

AMP_040M1_08F_B

D16

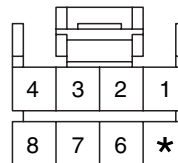

AMP_040M1_08F_B

BLANK

POWER OUTSIDE MIRRORS

POWER OUTSIDE MIRRORS (4)

SD876-4

MEMO

POWER OUTSIDE MIRROR FOLDING SYSTEM (1)

SD878-1

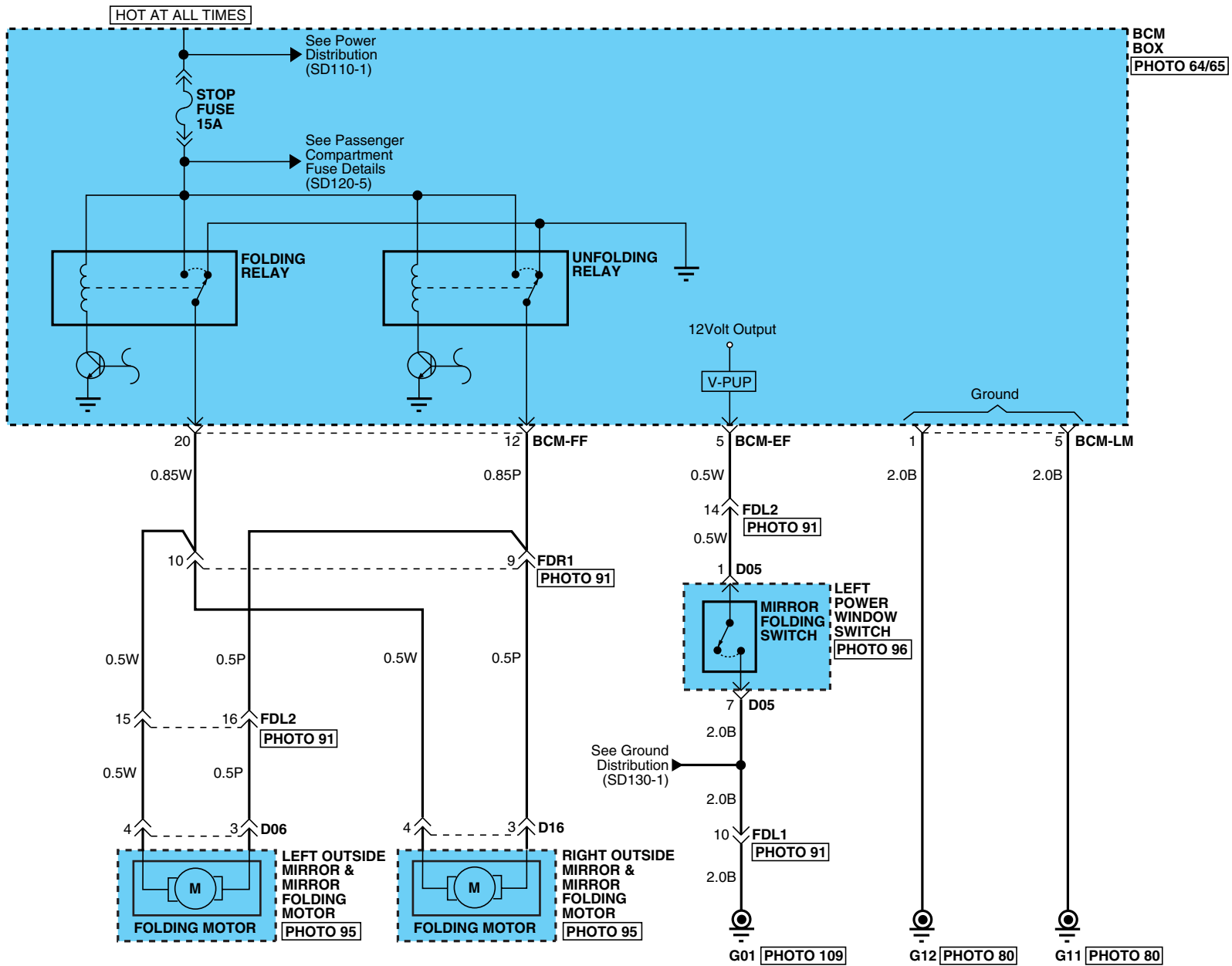

POWER OUTSIDE MIRROR FOLDING SYSTEM

POWER OUTSIDE MIRROR FOLDING SYSTEM (2)

SD878-2

D05

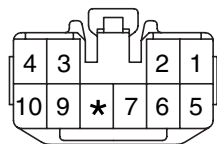

KET_090II_10F_W

D06

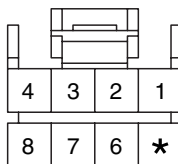

AMP_040M1_08F_B

D16

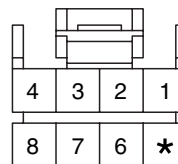

AMP_040M1_08F_B

BLANK

REAR WINDOW & OUTSIDE MIRROR DEFOGGER SYSTEM (1)

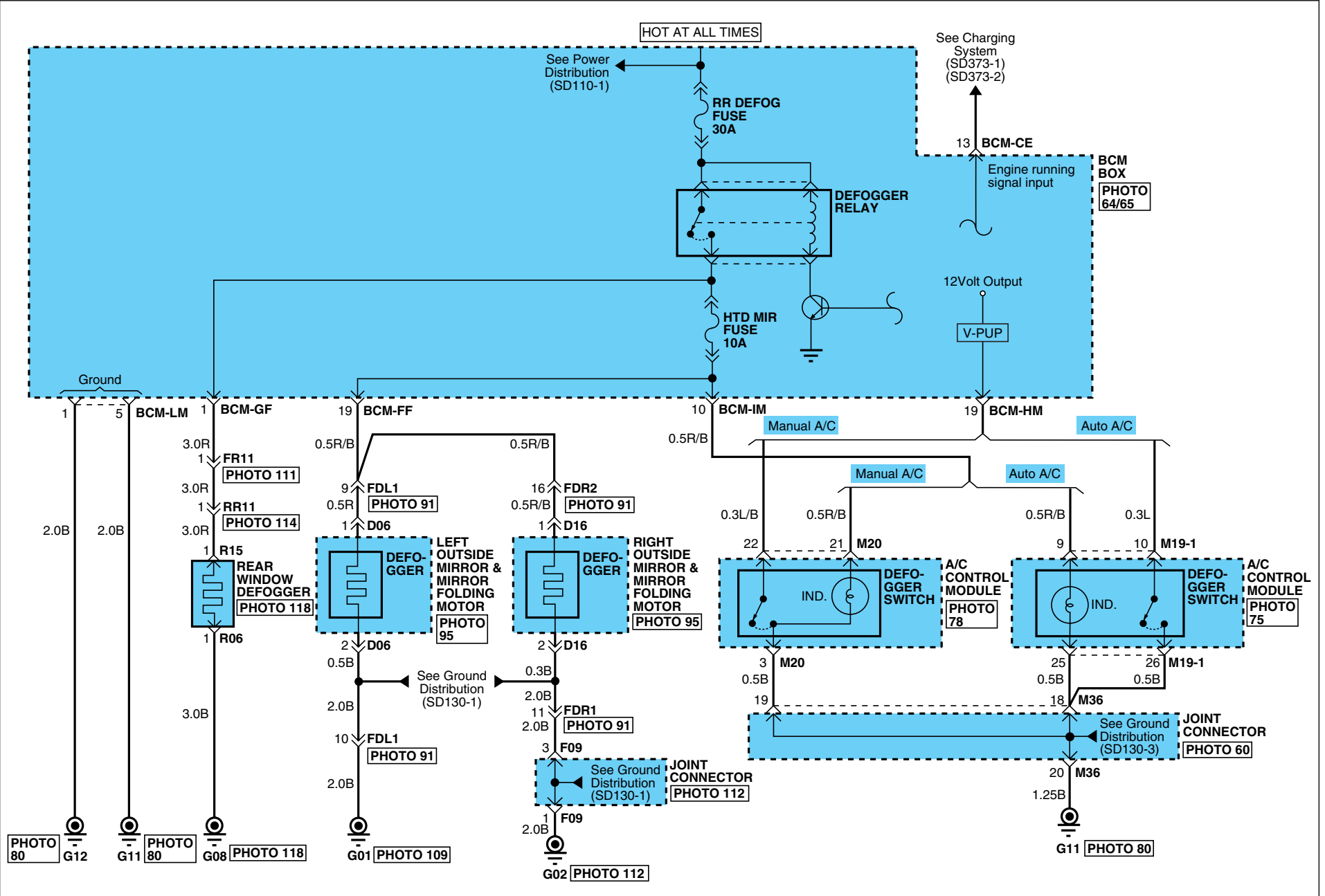

SD879-1



REAR WINDOW & OUTSIDE MIRROR DEFOGGER SYSTEM

REAR WINDOW & OUTSIDE MIRROR DEFOGGER SYSTEM (2)

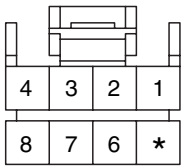
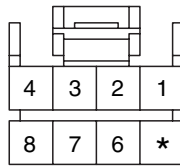
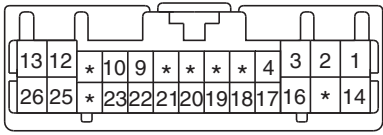
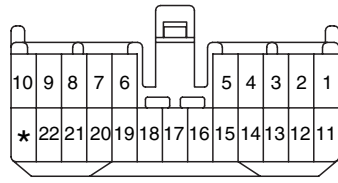
SD879-2

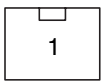
<p style="text-align: center;">D06</p>  <p style="text-align: center;">AMP_040M1_08F_B</p>	<p style="text-align: center;">D16</p>  <p style="text-align: center;">AMP_040M1_08F_B</p>	<p style="text-align: center;">M19-1</p>  <p style="text-align: center;">KET_0407_26F_W</p>	<p style="text-align: center;">M20</p>  <p style="text-align: center;">KET_050_23F_W</p>
<p style="text-align: center;">R06</p>  <p style="text-align: center;">CR01F006</p>	<p style="text-align: center;">R15</p>  <p style="text-align: center;">AMP_PLM1_01F_B</p>	<p style="text-align: center;">BLANK</p>	<p style="text-align: center;">BLANK</p>

SEAT WARMER (1)

SD889-1

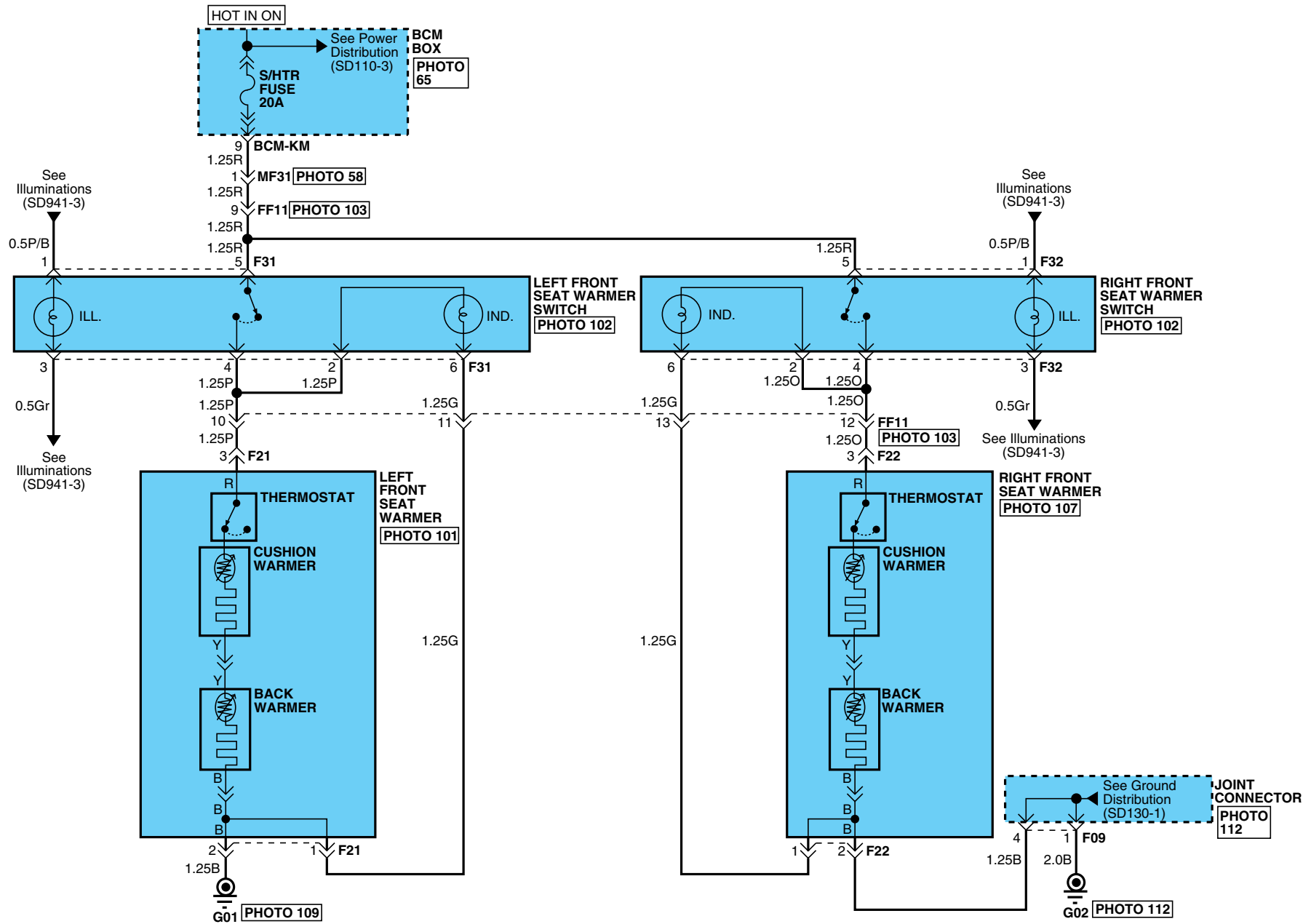

SEAT WARMER

SEAT WARMER (2)

SD889-2

F21

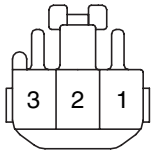

KET_090II_03F_W

F22

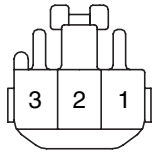

KET_090II_03F_W

F31

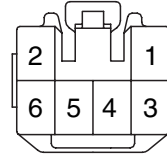

KET_090II_06F_L

F32

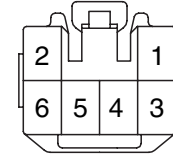

KET_090II_06F_W

HEAD LAMPS (1)

SD921-1

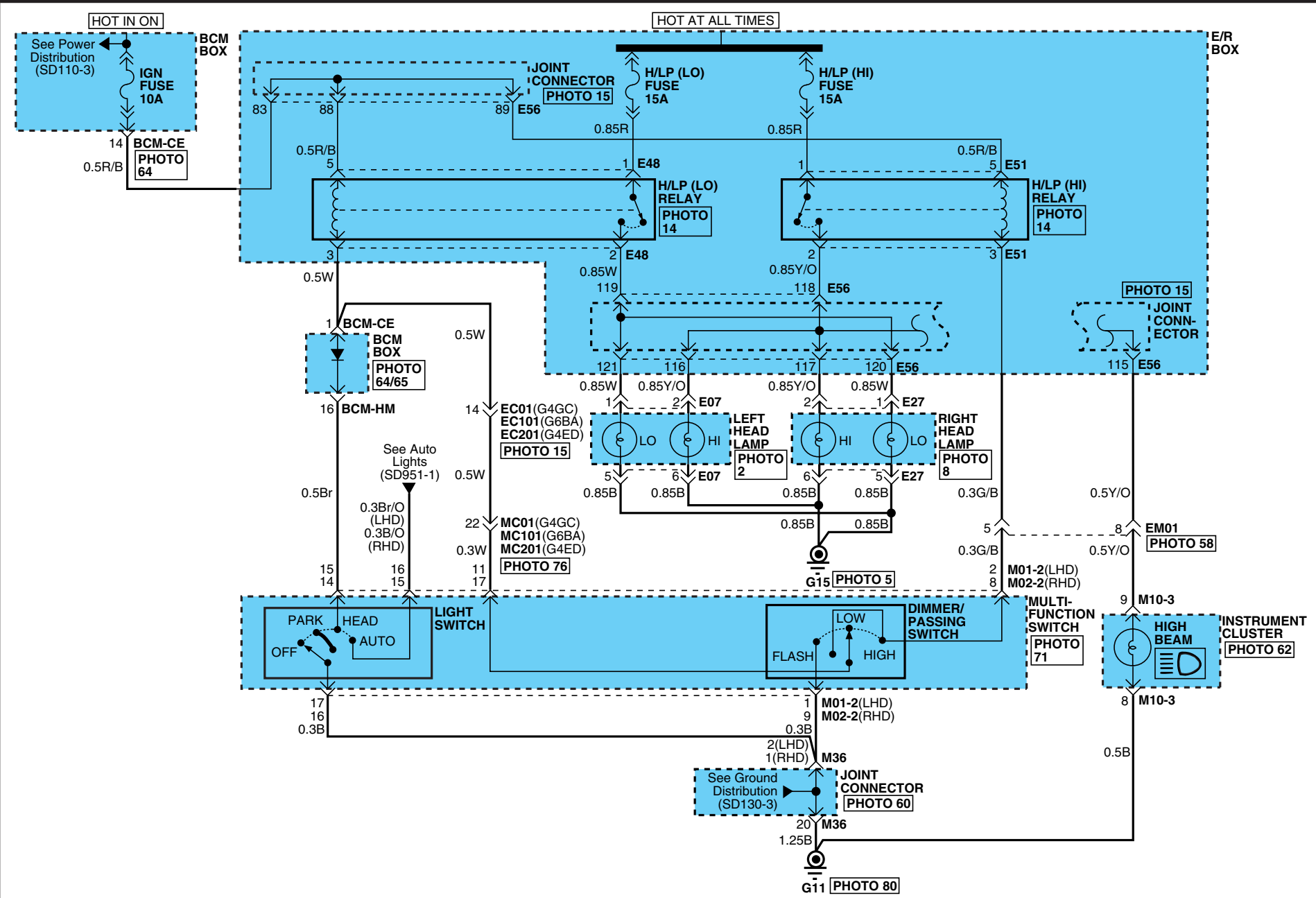

HEAD LAMPS

HEAD LAMPS (2)

SD921-2

E07

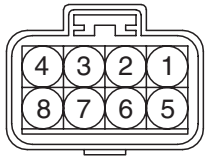

KUM_NMWP_08F_B

E27

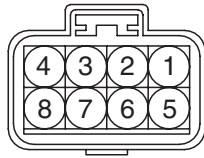

KUM_NMWP_08F_B

E48

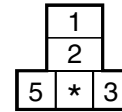

CR05F011

E51

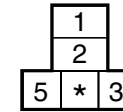

CR05F011

M01-2

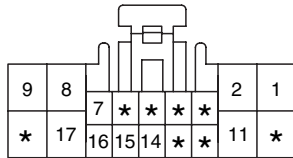

KET_0509_18F_W

M02-2

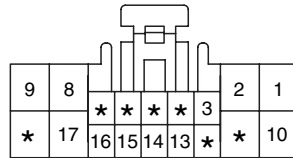

KET_0509_18F_W

M10-3

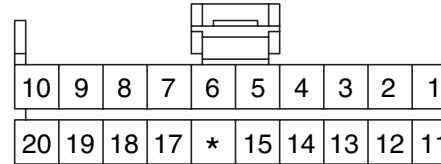

AMP_040M1_20F_B

BLANK

HEAD LAMP LEVELING DEVICE (1)

SD922-1

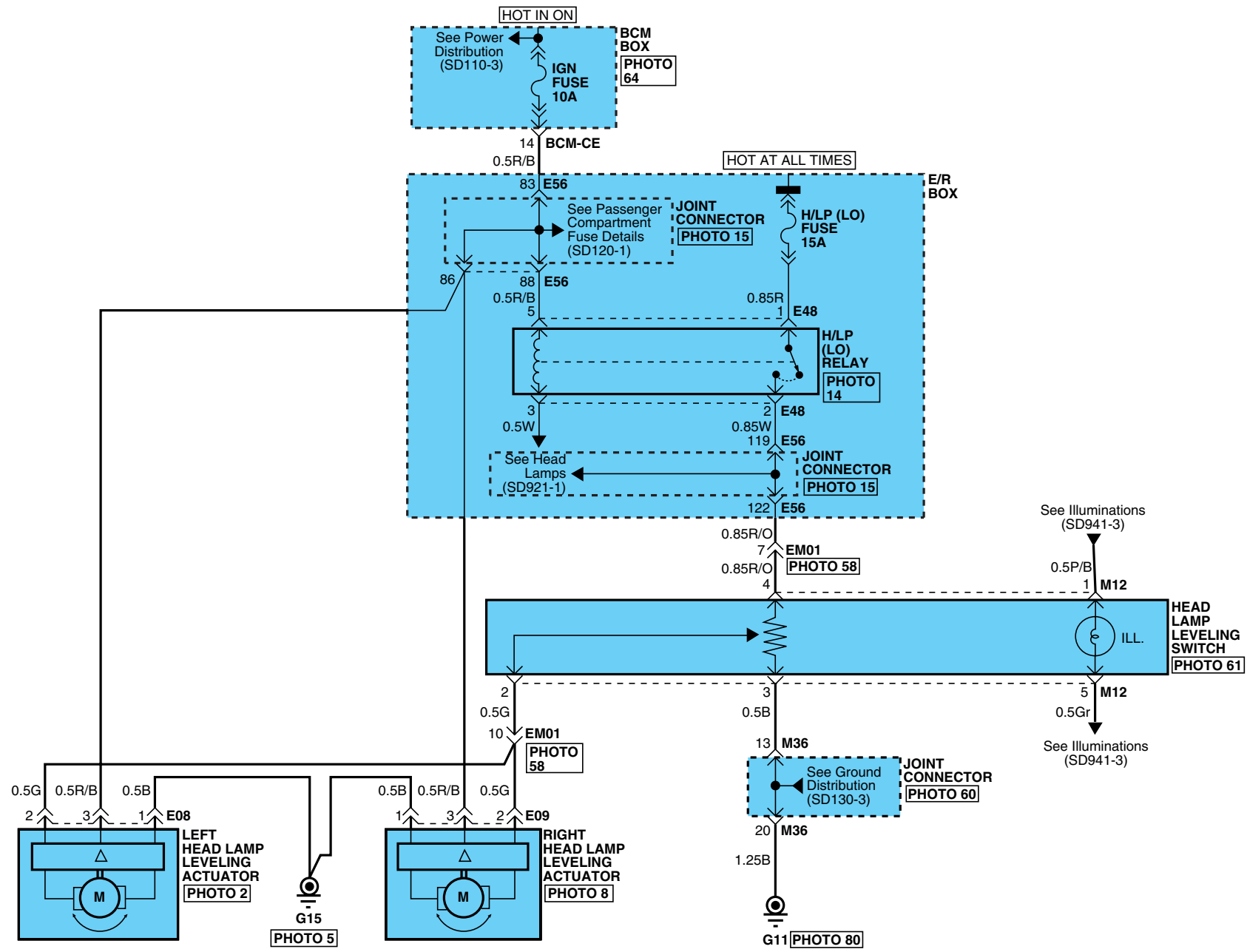

HEAD LAMP LEVELING DEVICE

HEAD LAMP LEVELING DEVICE (2)

SD922-2

E08

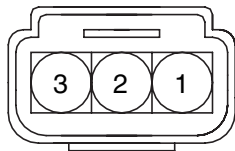

AMP_250WP_03F_B

E09

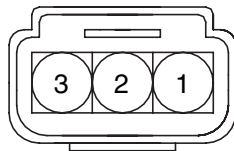

AMP_250WP_03F_B

E48

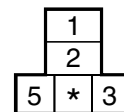

CR05F011

M12

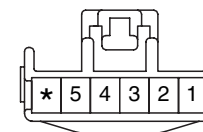

KET_090II_06F_W_SW

FOG LAMPS (1)

SD924-1

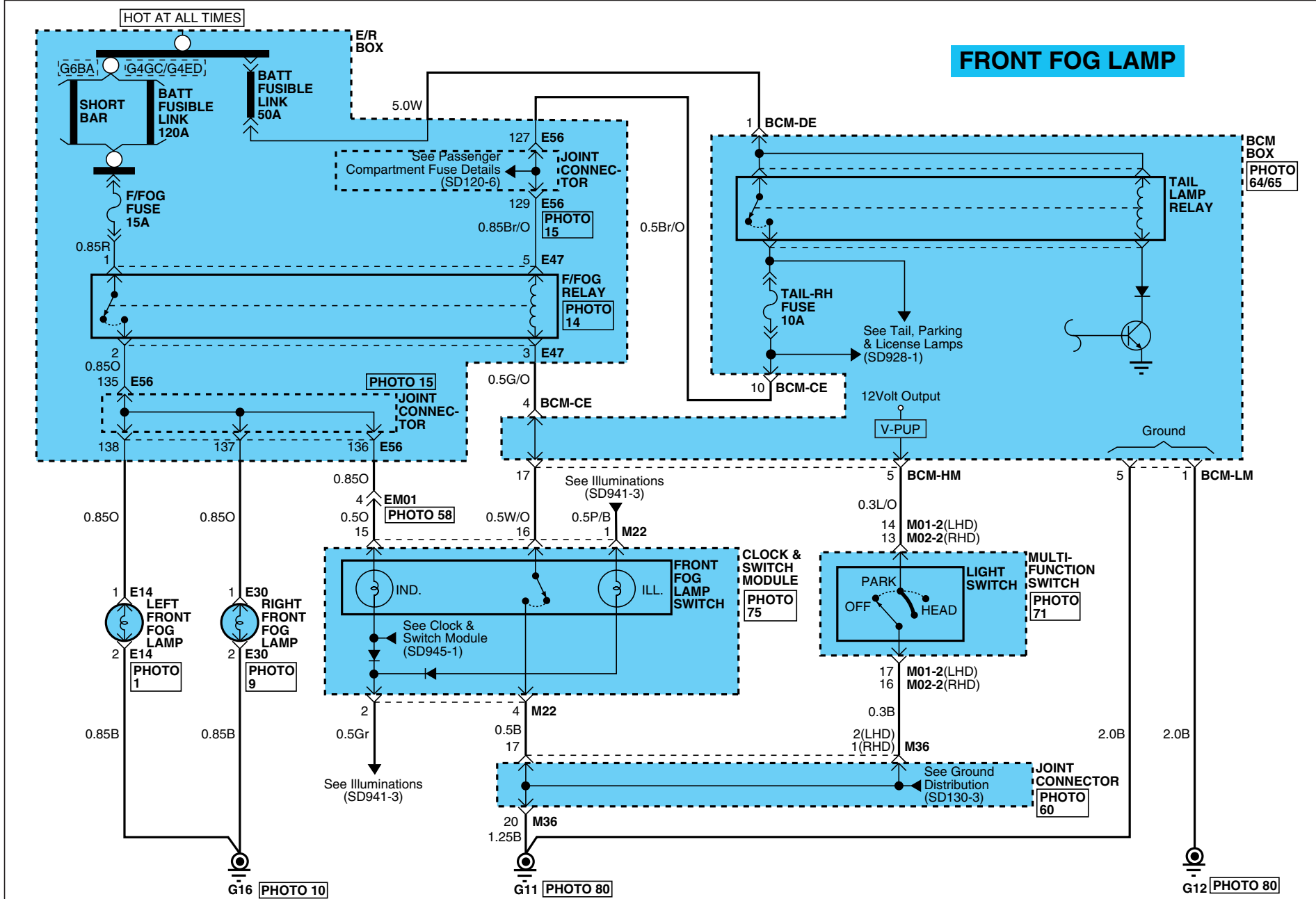

FOG LAMPS

FOG LAMPS (2)

SD924-2

REAR FOG LAMP

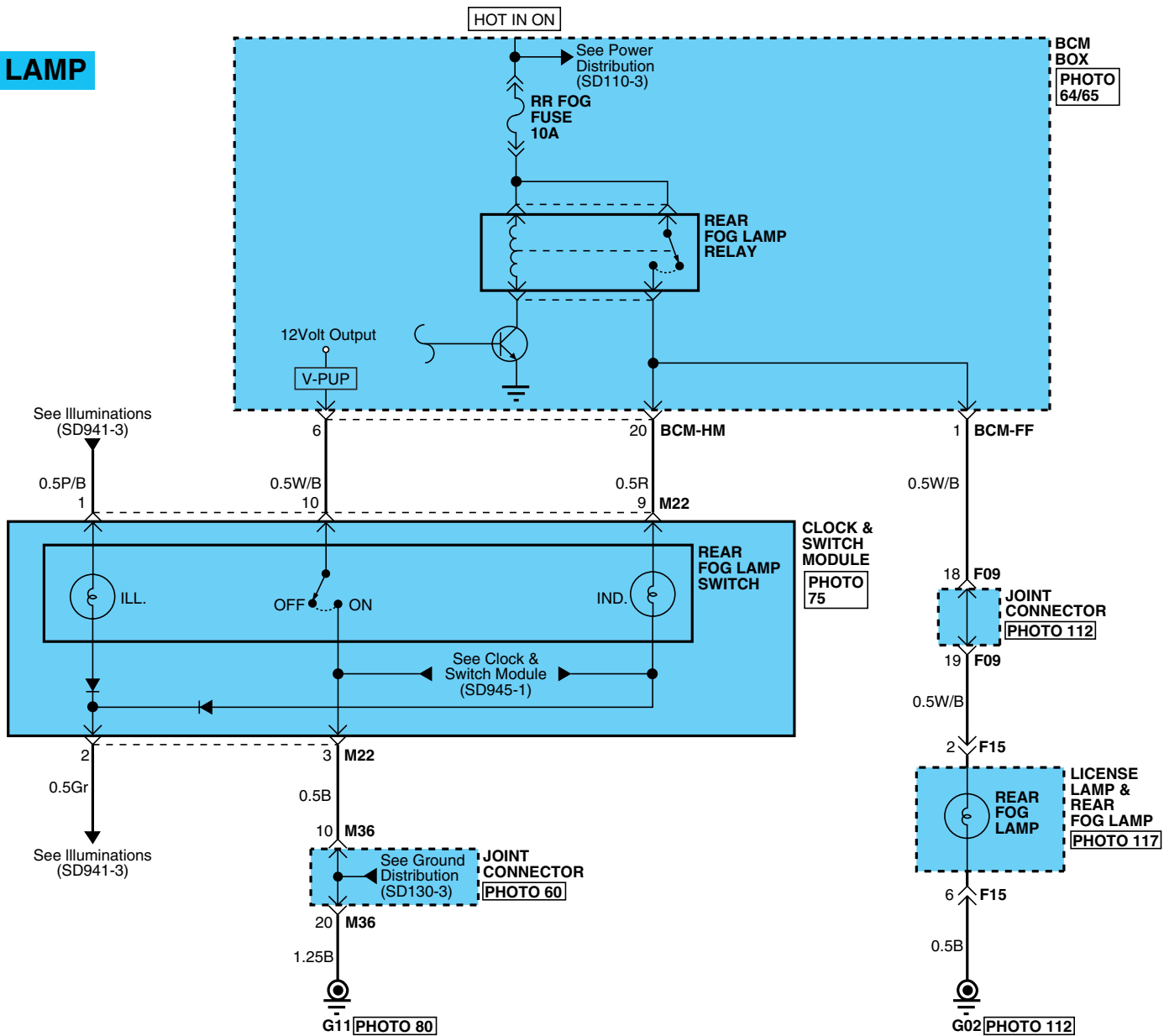

FOG LAMPS

FOG LAMPS (3)

SD924-3

E14

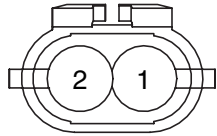

KET_110S_02F

E30

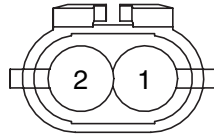

KET_110S_02F

E47

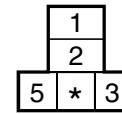

CR05F011

F15

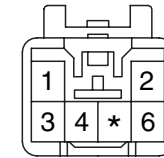

KET_090II_06M_W

M01-2

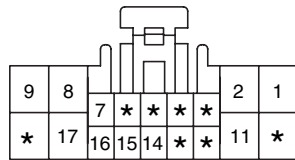

KET_0509_18F_W

M02-2

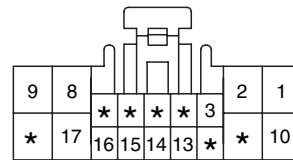

KET_0509_18F_W

M22

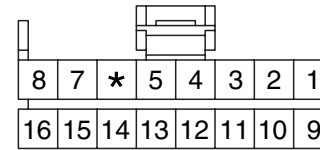

AMP_040M1_16F_B

BLANK

FOG LAMPS

FOG LAMPS (4)

SD924-4

MEMO

TURN & HAZARD LAMPS (1)

SD925-1

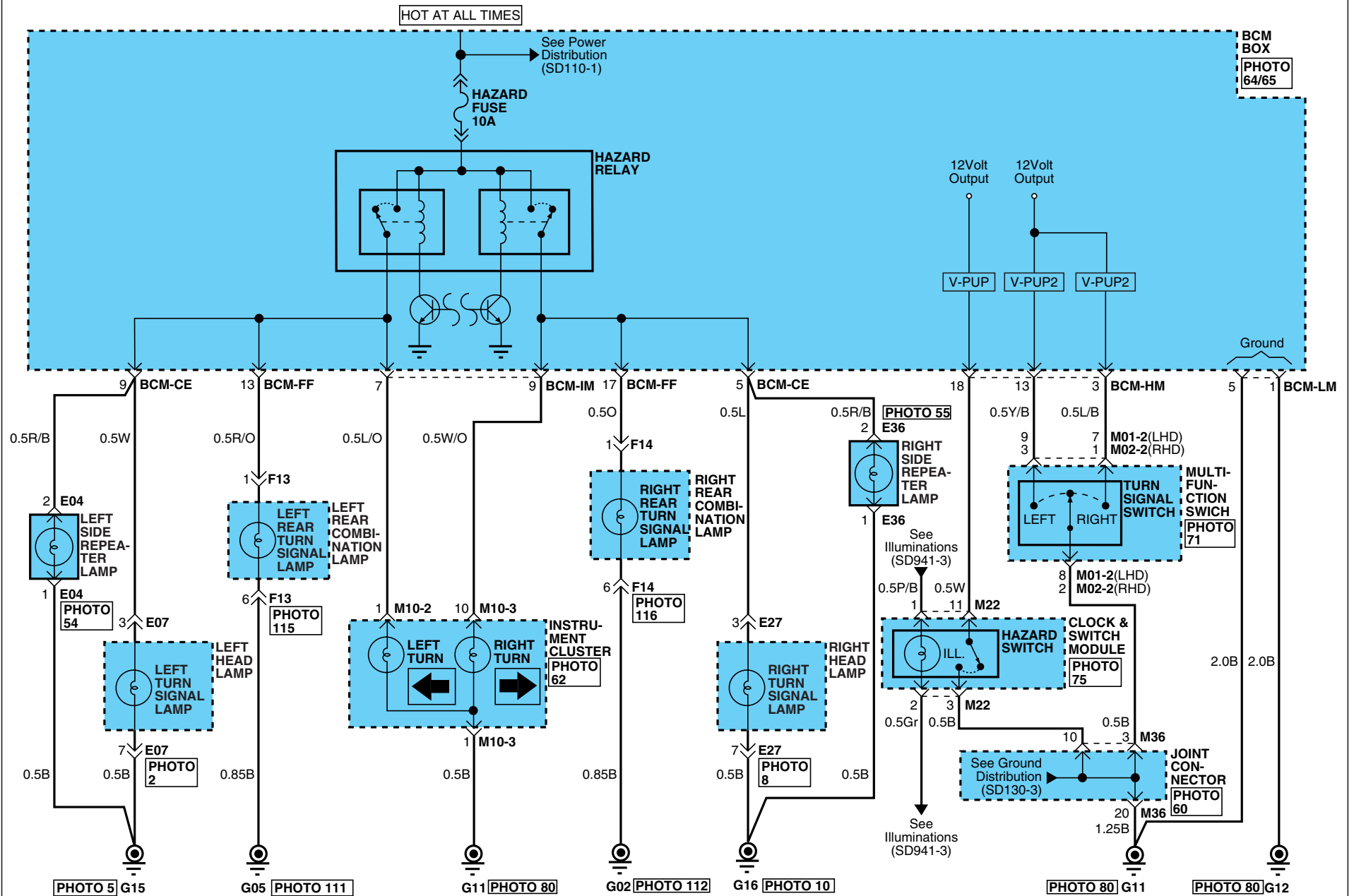

TURN & HAZARD LAMPS

TURN & HAZARD LAMPS (2)

SD925-2

E04

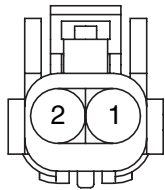

KUM_62Z_02F_GR

E07

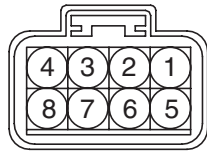

KUM_NMWP_08F_B

E27

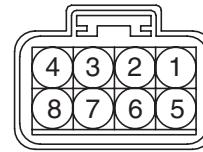

KUM_NMWP_08F_B

E36

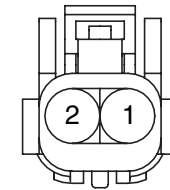

KUM_62Z_02F_GR

F13

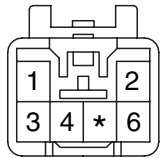

KET_090II_06M_W

F14

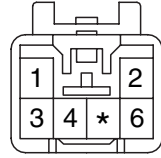

KET_090II_06M_W

M01-2

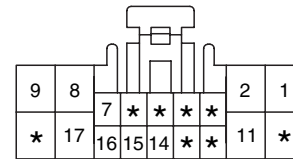

KET_0509_18F_W

M02-2

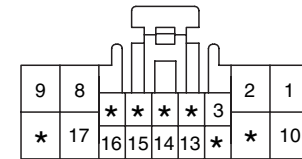

KET_0509_18F_W

M10-2

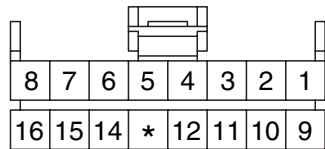

AMP_040M1_16F_B

M10-3

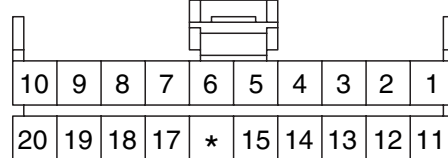

AMP_040M1_20F_B

M22

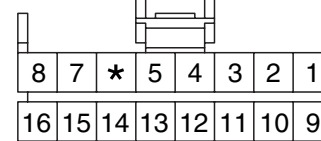

AMP_040M1_16F_B

BLANK

BACK-UP LAMPS (1)

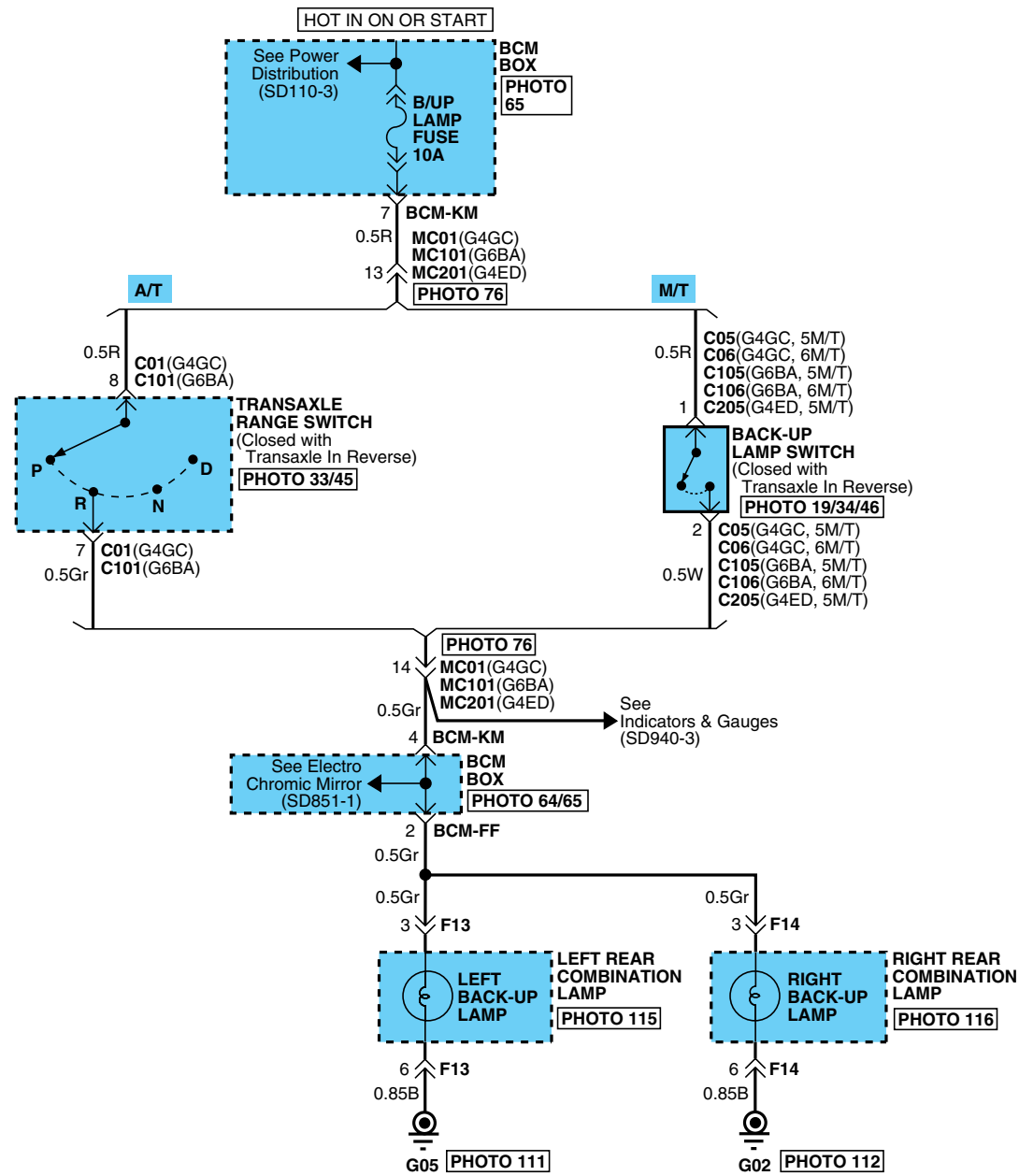

SD926-1



BACK-UP LAMPS

BACK-UP LAMPS (2)

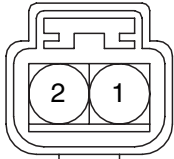
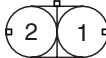
SD926-2

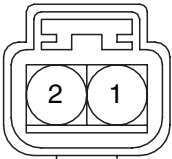
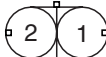
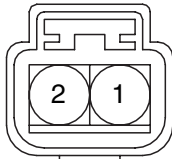
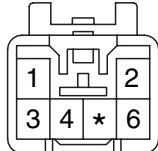
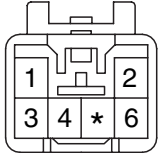
<p>C01</p>  <p>KET_SSD_10F_B_A</p>	<p>C05</p>  <p>KUM_NMWP_02F_B</p>	<p>C06</p>  <p>YAZ_91RVWP_02F_B</p>	<p>C101</p>  <p>KET_SSD_10F_B_A</p>
<p>C105</p>  <p>KUM_NMWP_02F_B</p>	<p>C106</p>  <p>YAZ_91RVWP_02F_B</p>	<p>C205</p>  <p>KUM_NMWP_02F_B</p>	<p>F13</p>  <p>KET_090II_06M_W</p>
<p>F14</p>  <p>KET_090II_06M_W</p>	<p>BLANK</p>	<p>BLANK</p>	<p>BLANK</p>

STOP LAMPS (1)

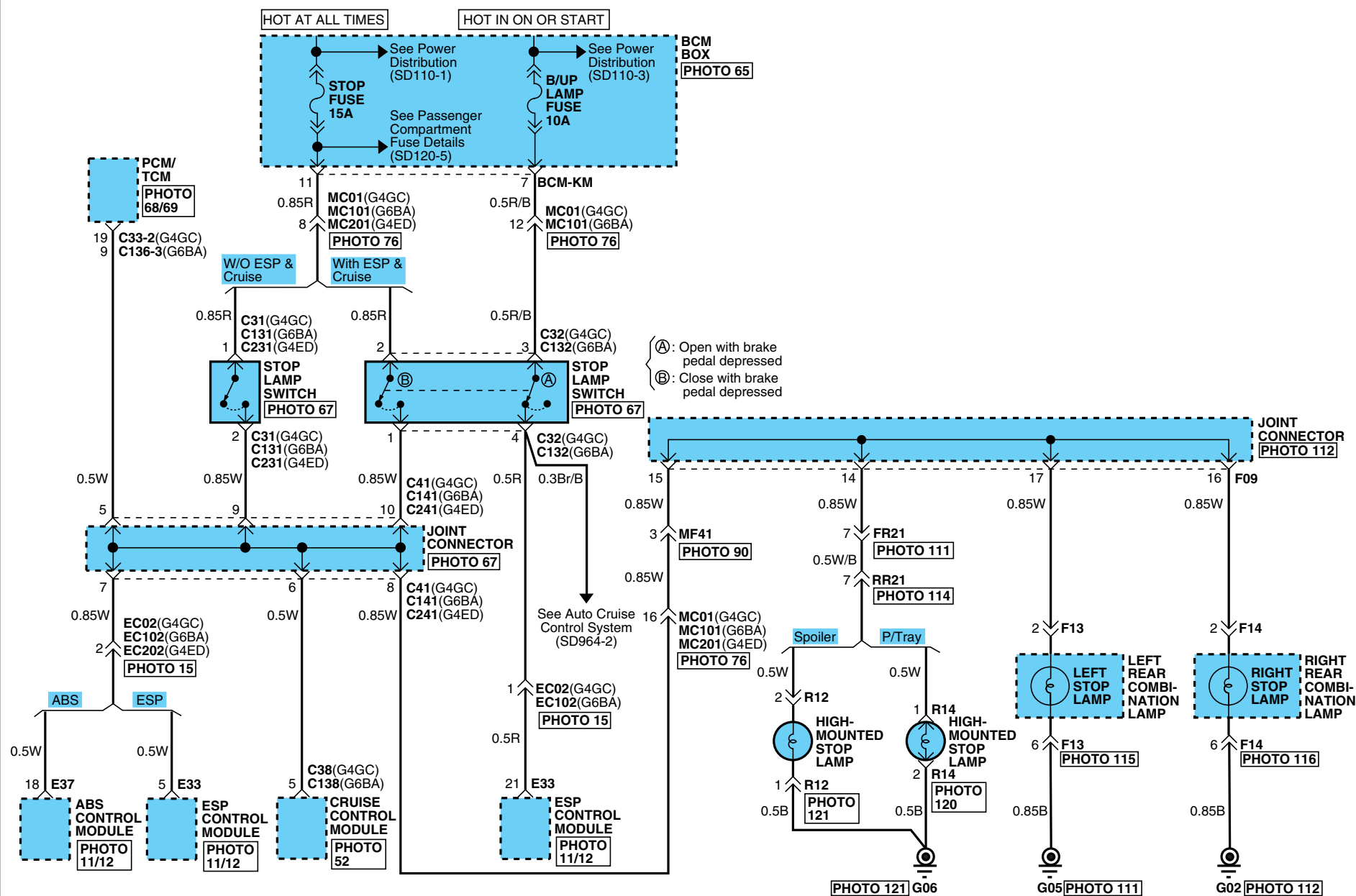

STOP LAMPS

STOP LAMPS (2)

SD927-2

C31/C131/C231

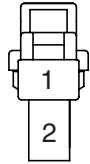

KET_250L_02F_W

C32/C132

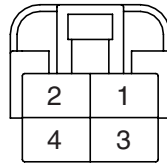

KET_250DL_04F_W

C33-2

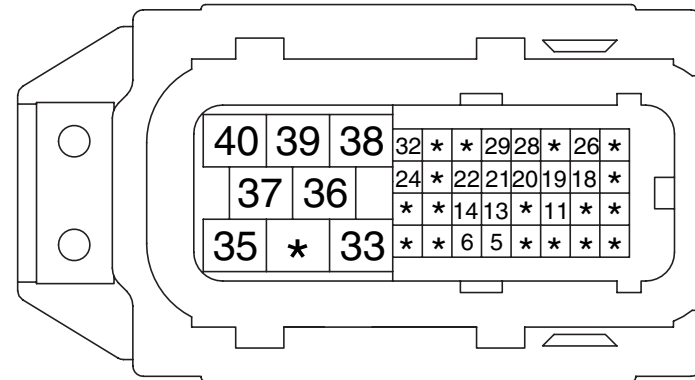

KET_ECU_40F_B

C38/C138

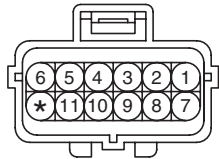

AMP_EJWP_12F_B

C136-3

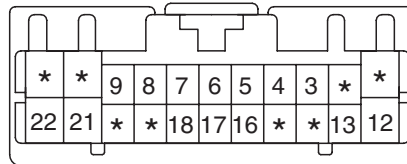

KET_0407_22F_W

E33

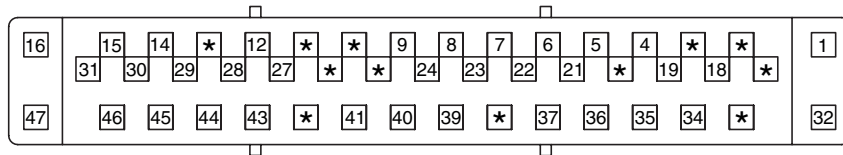

AMP_ESP_47F_L_UNIT

E37

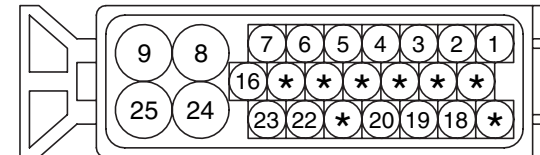

AMP_ABSWP_25F_B_GER

F13

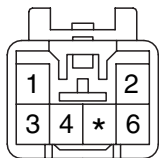

KET_090II_06M_W

F14

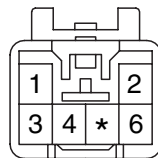

KET_090II_06M_W

R12

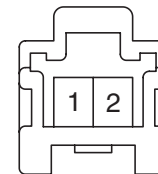

KET_070_02M_W

R14

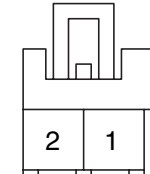

KUM_CDR_02F_W

TAIL, PARKING & LICENSE LAMPS (1)

SD928-1

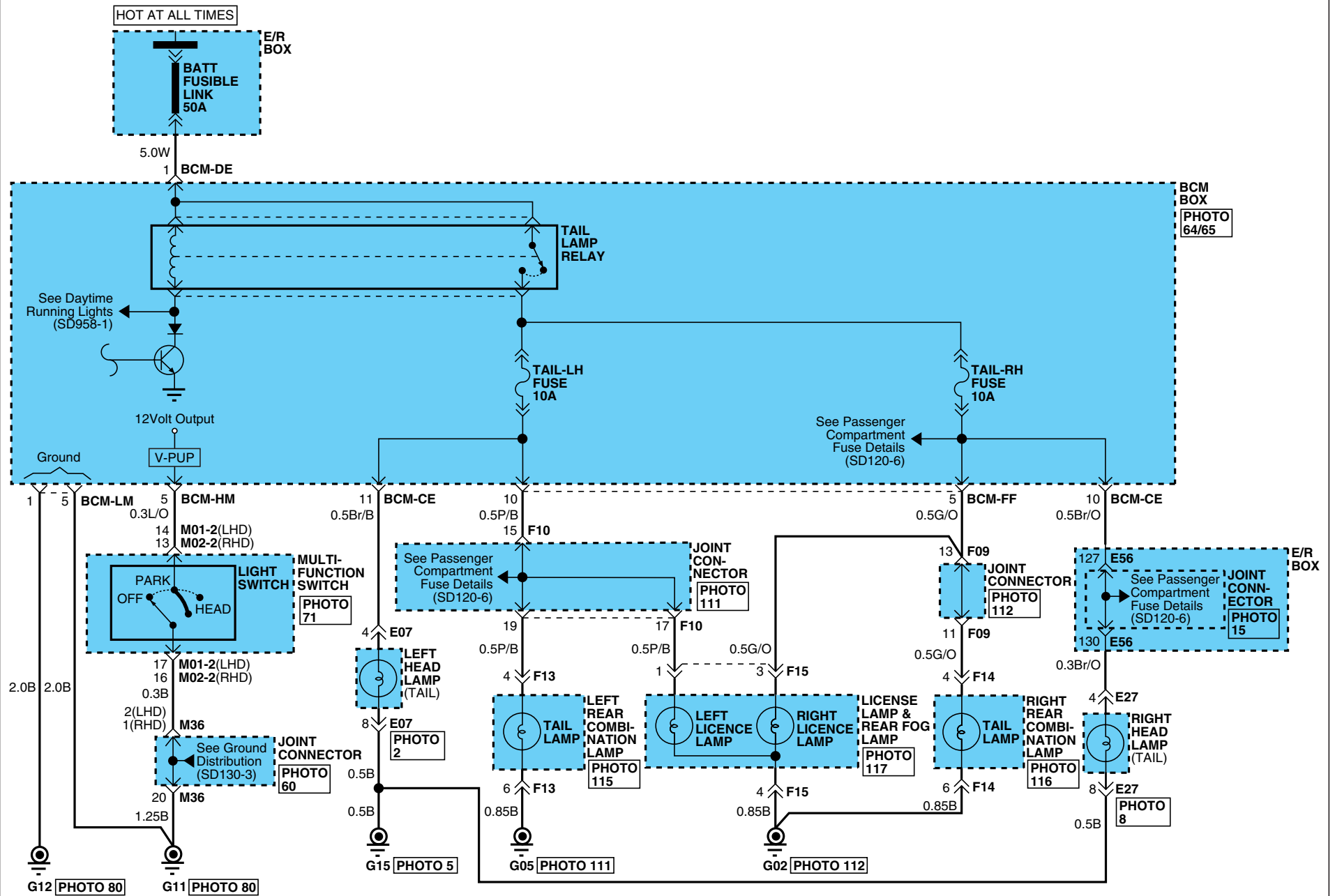

TAIL, PARKING & LICENSE LAMPS

TAIL, PARKING & LICENSE LAMPS (2)

SD928-2

E07

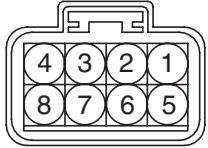

KUM_NMWP_08F_B

E27

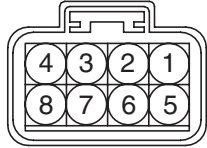

KUM_NMWP_08F_B

F13

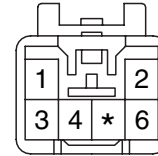

KET_090II_06M_W

F14

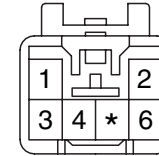

KET_090II_06M_W

F15

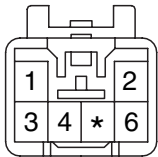

KET_090II_06M_W

M01-2

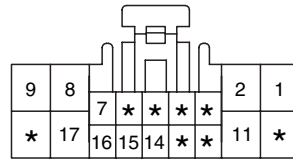

KET_0509_18F_W

M02-2

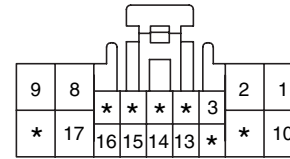

KET_0509_18F_W

BLANK

COURTESY & LUGGAGE ROOM LAMPS

COURTESY & LUGGAGE ROOM LAMPS (2)

SD929-2

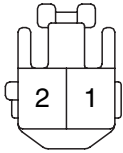
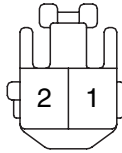
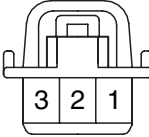
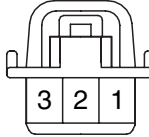
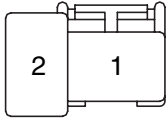
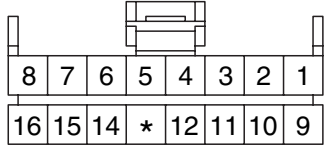
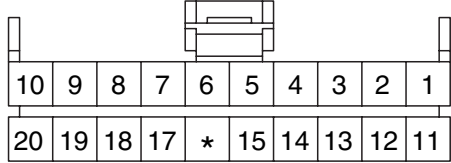
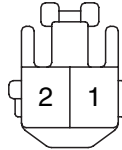
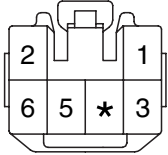
<p>D08</p>  <p>KET_090II_02F_W_L</p>	<p>D18</p>  <p>KET_090II_02F_W_L</p>	<p>F03</p>  <p>KET_62C_03F_W_DR</p>	<p>F04</p>  <p>KET_62C_03F_W_DR</p>
<p>F11</p>  <p>AMP_PLM2_02F_B</p>	<p>M10-2</p>  <p>AMP_040M1_16F_B</p>	<p>M10-3</p>  <p>AMP_040M1_20F_B</p>	<p>R17</p>  <p>KET_090II_02F_W_L</p>
<p>R22</p>  <p>KET_090II_06F_W</p>	<p>BLANK</p>	<p>BLANK</p>	<p>BLANK</p>

INDICATORS & GAUGES (1)

SD940-1

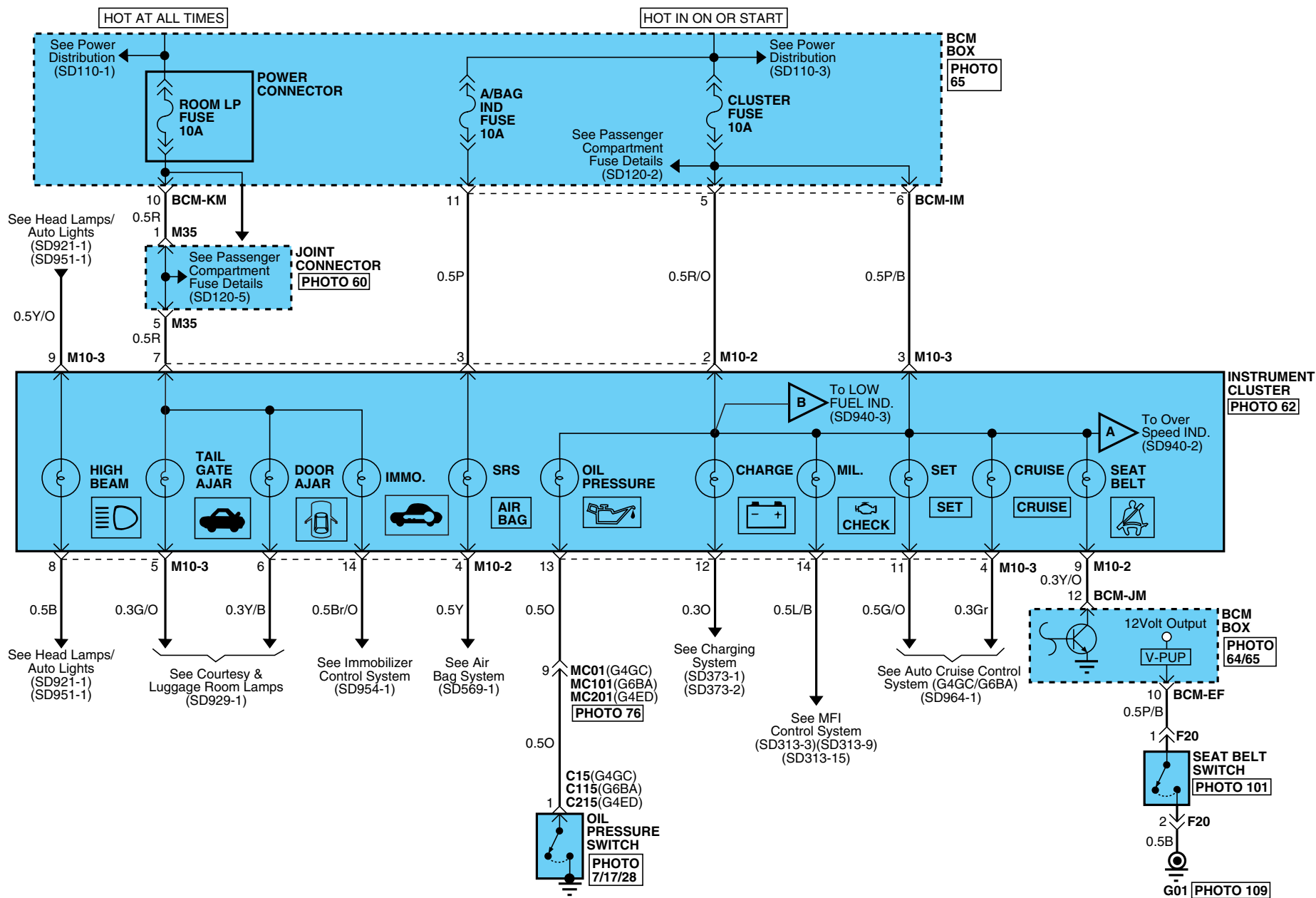

INDICATORS & GAUGES

INDICATORS & GAUGES (2)

SD940-2

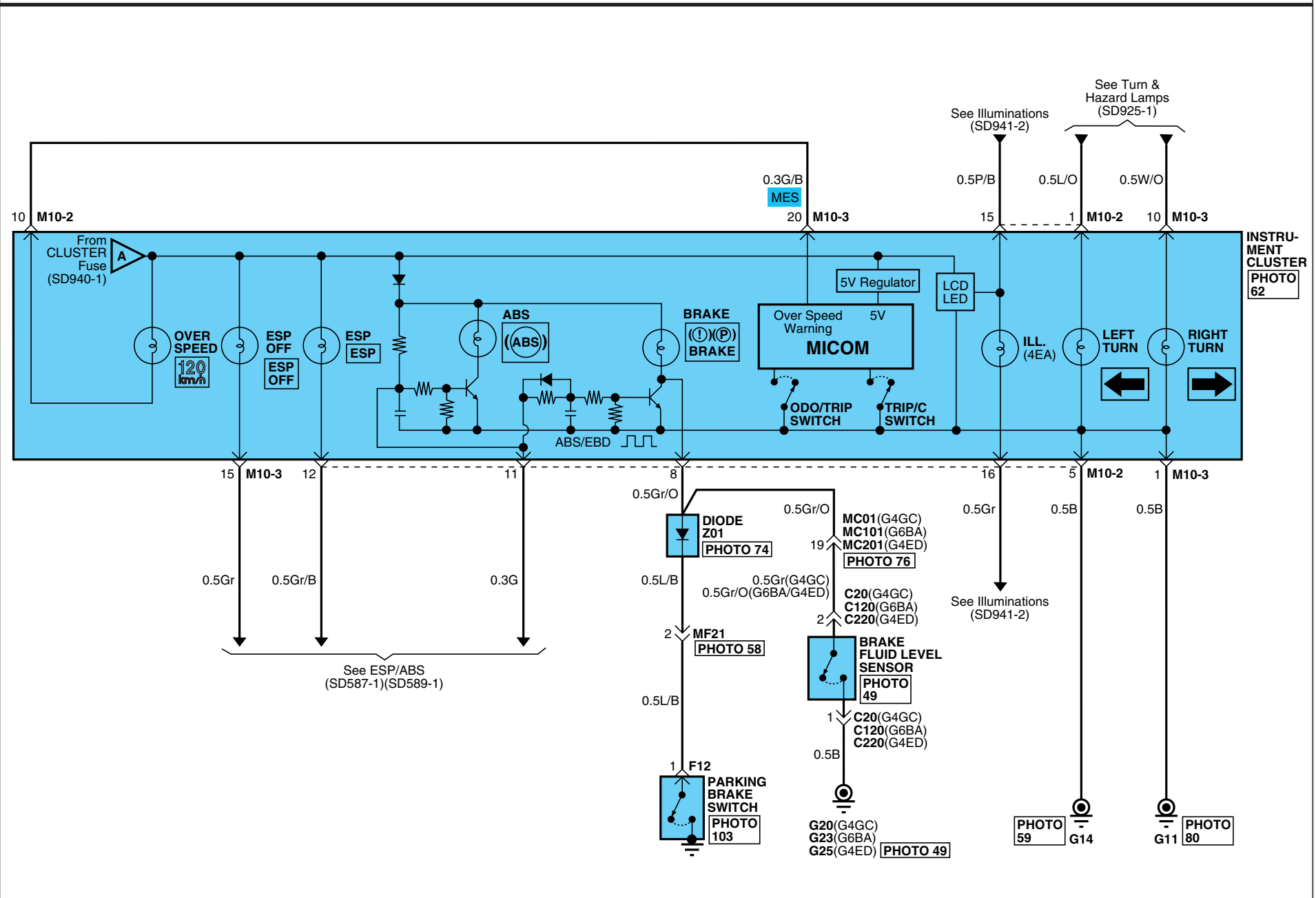

INDICATORS & GAUGES

INDICATORS & GAUGES (3)

SD940-3

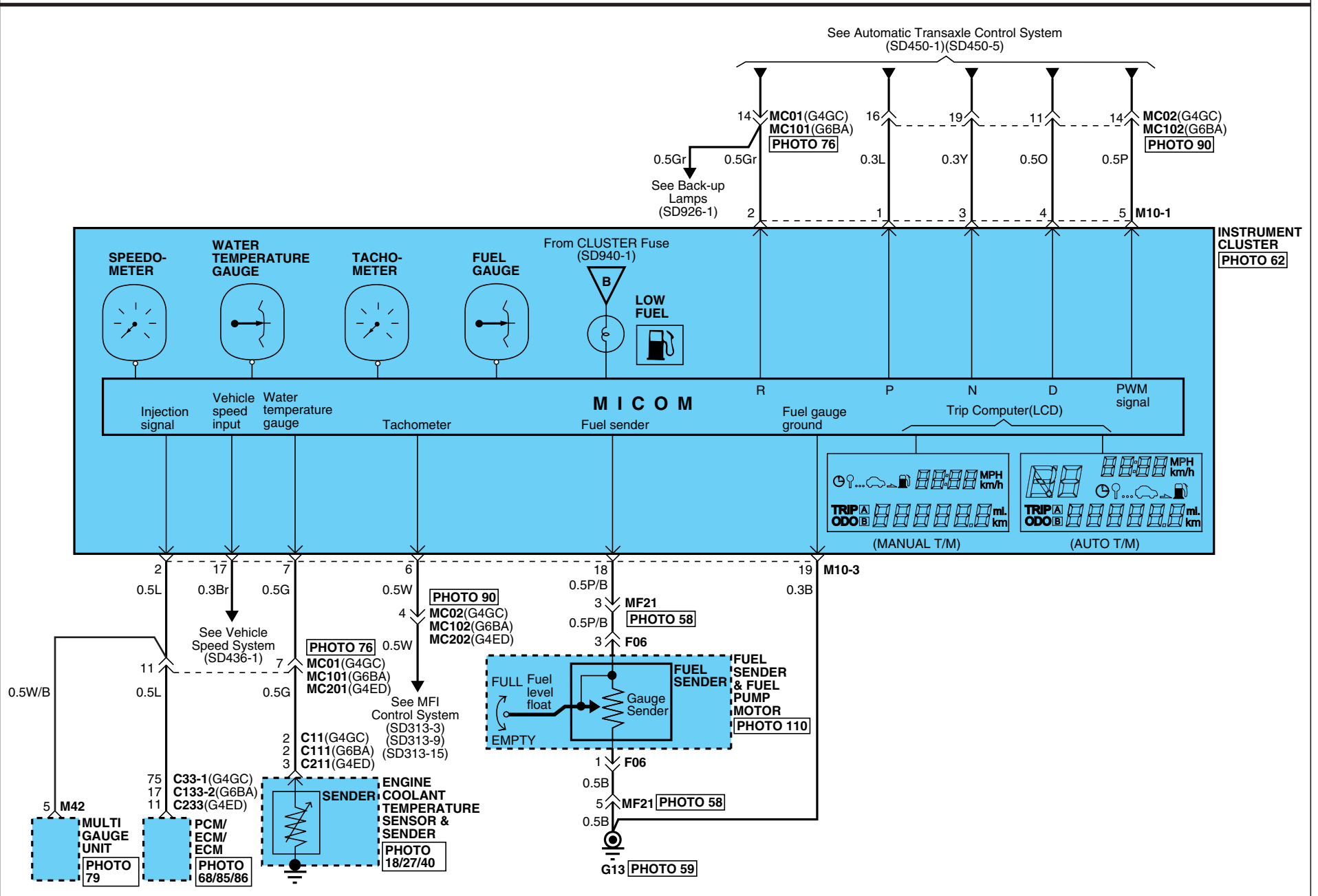



INDICATORS & GAUGES

INDICATORS & GAUGES (4)

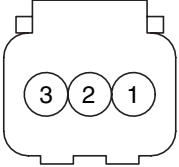
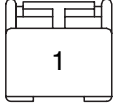
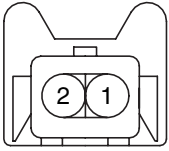
SD940-4

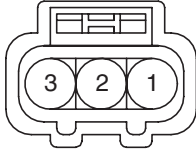
<p>C11</p>  <p style="text-align: right; font-size: small;">KUM_WTS_03F_B</p>	<p>C15/C215</p>  <p style="text-align: right; font-size: small;">AMP_PLM2_01F_B</p>	<p>C20/C120/C220</p>  <p style="text-align: right; font-size: small;">AMP_JPT_02F_B</p>	<p>BLANK</p>
---	---	---	---------------------

<p>C33-1</p> <table border="1" style="width:100%; border-collapse: collapse; font-size: x-small;"> <tr><td>6</td><td>7</td><td>8</td><td>9</td><td>10</td><td>11</td><td>*</td><td>*</td><td>14</td><td>*</td><td>*</td><td>17</td><td>18</td><td>*</td><td>*</td><td>21</td><td>22</td><td>23</td><td>24</td><td>5</td><td>4</td></tr> <tr><td>*</td><td>26</td><td>27</td><td>*</td><td>29</td><td>30</td><td>31</td><td>32</td><td>*</td><td>*</td><td>*</td><td>*</td><td>37</td><td>38</td><td>39</td><td>*</td><td>*</td><td>42</td><td>43</td><td colspan="2" rowspan="2" style="text-align: center; vertical-align: middle;">3</td></tr> <tr><td>44</td><td>45</td><td>*</td><td>47</td><td>48</td><td>*</td><td>50</td><td>51</td><td>52</td><td>*</td><td>54</td><td>55</td><td>56</td><td>*</td><td>58</td><td>59</td><td>60</td><td>61</td><td>62</td></tr> <tr><td>*</td><td>64</td><td>65</td><td>66</td><td>67</td><td>68</td><td>69</td><td>70</td><td>*</td><td>72</td><td>73</td><td>*</td><td>75</td><td>76</td><td>77</td><td>78</td><td>*</td><td>80</td><td>81</td><td>2</td><td>1</td></tr> </table> <p style="text-align: right; font-size: x-small;">KET_ECU_81F_B_BOSCH</p>	6	7	8	9	10	11	*	*	14	*	*	17	18	*	*	21	22	23	24	5	4	*	26	27	*	29	30	31	32	*	*	*	*	37	38	39	*	*	42	43	3		44	45	*	47	48	*	50	51	52	*	54	55	56	*	58	59	60	61	62	*	64	65	66	67	68	69	70	*	72	73	*	75	76	77	78	*	80	81	2	1	<p>C111</p>  <p style="text-align: right; font-size: small;">KUM_62Z_03F_B_WTS</p>	<p>C115</p>  <p style="text-align: right; font-size: small;">KUM_NMWP_01F_B</p>
6	7	8	9	10	11	*	*	14	*	*	17	18	*	*	21	22	23	24	5	4																																																																
*	26	27	*	29	30	31	32	*	*	*	*	37	38	39	*	*	42	43	3																																																																	
44	45	*	47	48	*	50	51	52	*	54	55	56	*	58	59	60	61	62																																																																		
*	64	65	66	67	68	69	70	*	72	73	*	75	76	77	78	*	80	81	2	1																																																																

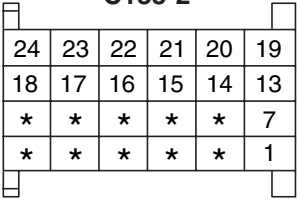
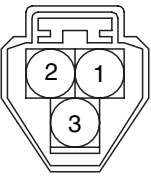
<p>C133-2</p>  <p style="text-align: right; font-size: small;">AMP_ECU_24F_B_134P</p>	<p>C211</p>  <p style="text-align: right; font-size: small;">KUM_NMWP_03F_B</p>	<p>C233</p> <table border="1" style="width:100%; border-collapse: collapse; font-size: x-small;"> <tr><td>6</td><td>7</td><td>8</td><td>*</td><td>*</td><td>11</td><td>12</td><td>13</td><td>14</td><td>15</td><td>16</td><td>17</td><td>18</td><td>19</td><td>20</td><td>*</td><td>*</td><td>*</td><td>24</td><td>5</td><td>*</td></tr> <tr><td>*</td><td>26</td><td>27</td><td>28</td><td>29</td><td>*</td><td>31</td><td>32</td><td>33</td><td>34</td><td>35</td><td>36</td><td>37</td><td>*</td><td>39</td><td>*</td><td>*</td><td>42</td><td>*</td><td colspan="2" rowspan="2" style="text-align: center; vertical-align: middle;">3</td></tr> <tr><td>44</td><td>45</td><td>46</td><td>47</td><td>48</td><td>49</td><td>50</td><td>51</td><td>52</td><td>53</td><td>*</td><td>55</td><td>*</td><td>57</td><td>*</td><td>59</td><td>60</td><td>61</td><td>*</td></tr> <tr><td>63</td><td>*</td><td>*</td><td>*</td><td>*</td><td>68</td><td>69</td><td>70</td><td>71</td><td>*</td><td>73</td><td>74</td><td>75</td><td>*</td><td>*</td><td>*</td><td>79</td><td>80</td><td>*</td><td>2</td><td>*</td></tr> </table> <p style="text-align: right; font-size: x-small;">KET_ECU_81F_B_BOSCH</p>		6	7	8	*	*	11	12	13	14	15	16	17	18	19	20	*	*	*	24	5	*	*	26	27	28	29	*	31	32	33	34	35	36	37	*	39	*	*	42	*	3		44	45	46	47	48	49	50	51	52	53	*	55	*	57	*	59	60	61	*	63	*	*	*	*	68	69	70	71	*	73	74	75	*	*	*	79	80	*	2	*
6	7	8	*	*	11	12	13	14	15	16	17	18	19	20	*	*	*	24	5	*																																																																	
*	26	27	28	29	*	31	32	33	34	35	36	37	*	39	*	*	42	*	3																																																																		
44	45	46	47	48	49	50	51	52	53	*	55	*	57	*	59	60	61	*																																																																			
63	*	*	*	*	68	69	70	71	*	73	74	75	*	*	*	79	80	*	2	*																																																																	

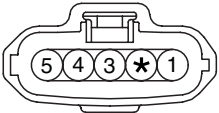
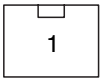
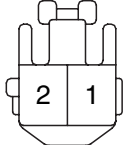
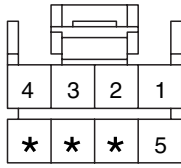
<p>F06</p>  <p style="text-align: right; font-size: small;">KET_090IWP_05F_B_1</p>	<p>F12</p>  <p style="text-align: right; font-size: small;">AMP_PLM1_01F_B</p>	<p>F20</p>  <p style="text-align: right; font-size: small;">KET_090II_02F_W_L</p>	<p>M10-1</p>  <p style="text-align: right; font-size: small;">AMP_040M1_08F_B</p>
--	--	---	---

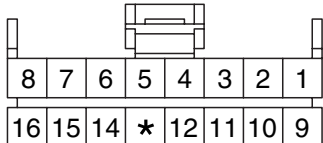
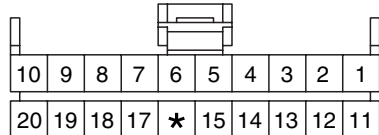
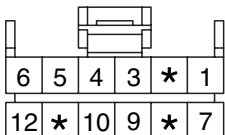
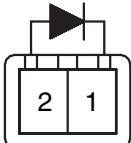
<p>M10-2</p>  <p style="text-align: right; font-size: small;">AMP_040M1_16F_B</p>	<p>M10-3</p>  <p style="text-align: right; font-size: small;">AMP_040M1_20F_B</p>	<p>M42</p>  <p style="text-align: right; font-size: small;">AMP_040M1_12F_B</p>	<p>Z01</p>  <p style="text-align: right; font-size: small;">KET_090_02F_B_DIODE</p>
---	--	---	---

ILLUMINATIONS (1)

SD941-1

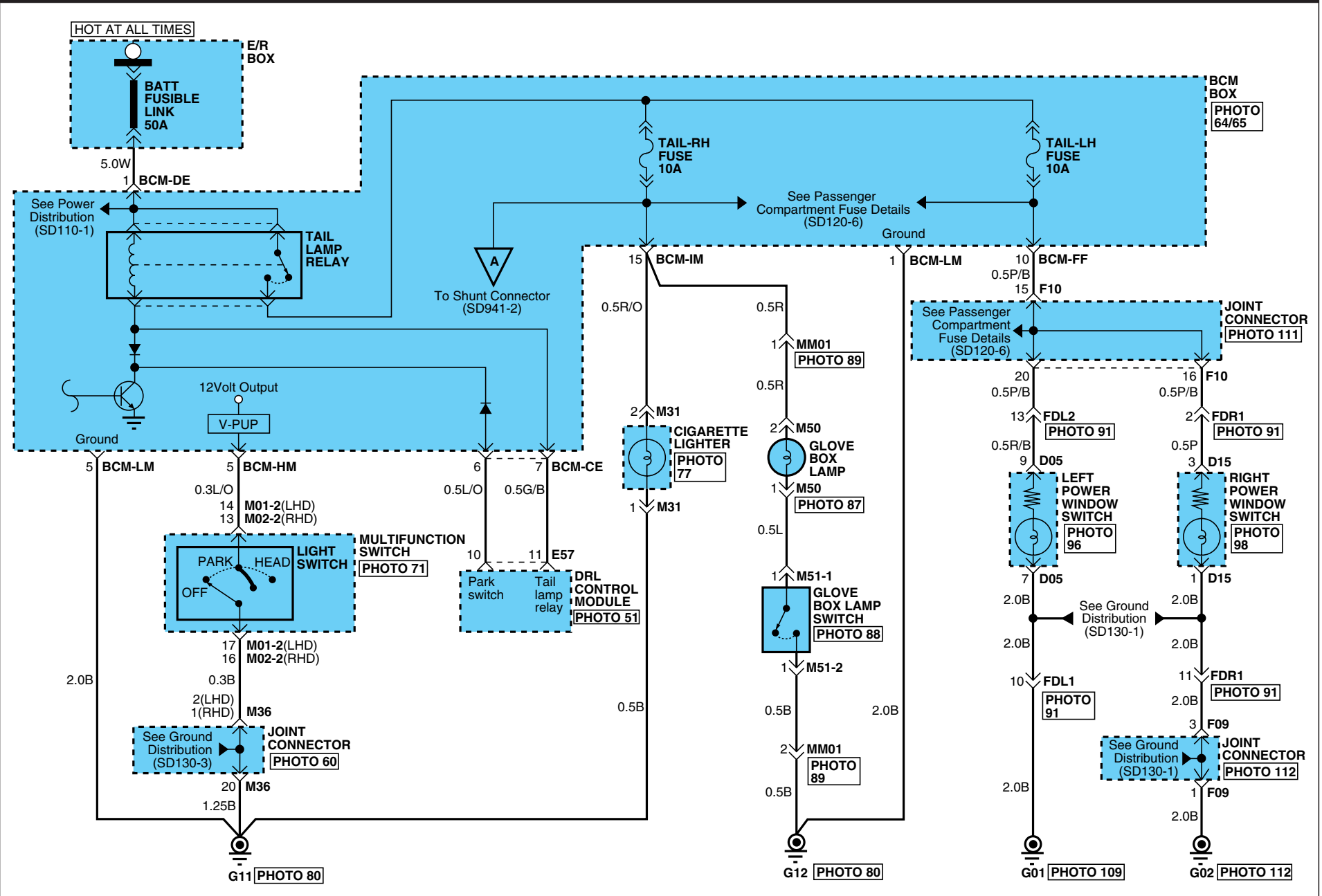

ILLUMINATIONS

ILLUMINATIONS (2)

SD941-2

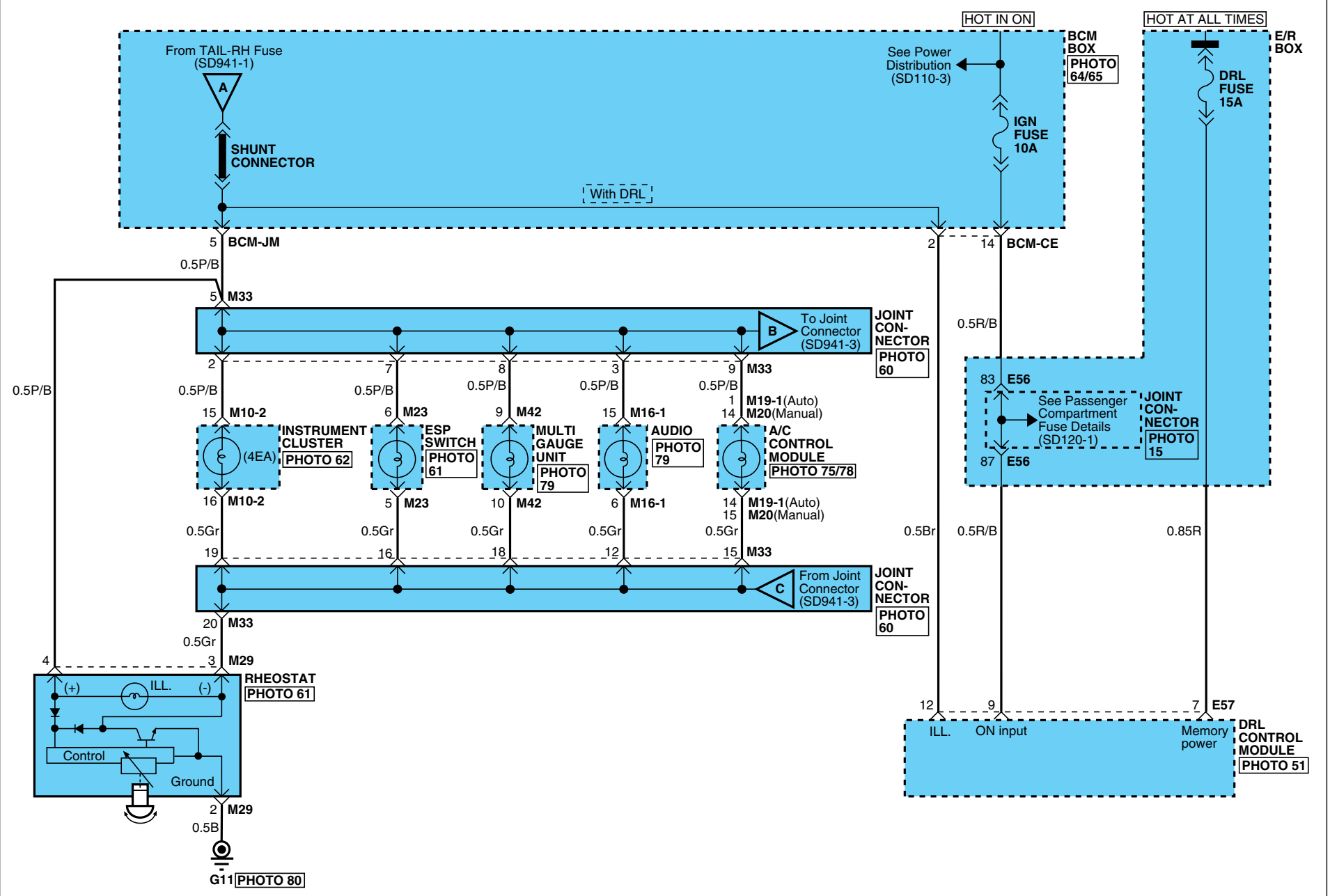



ILLUMINATIONS

ILLUMINATIONS (3)

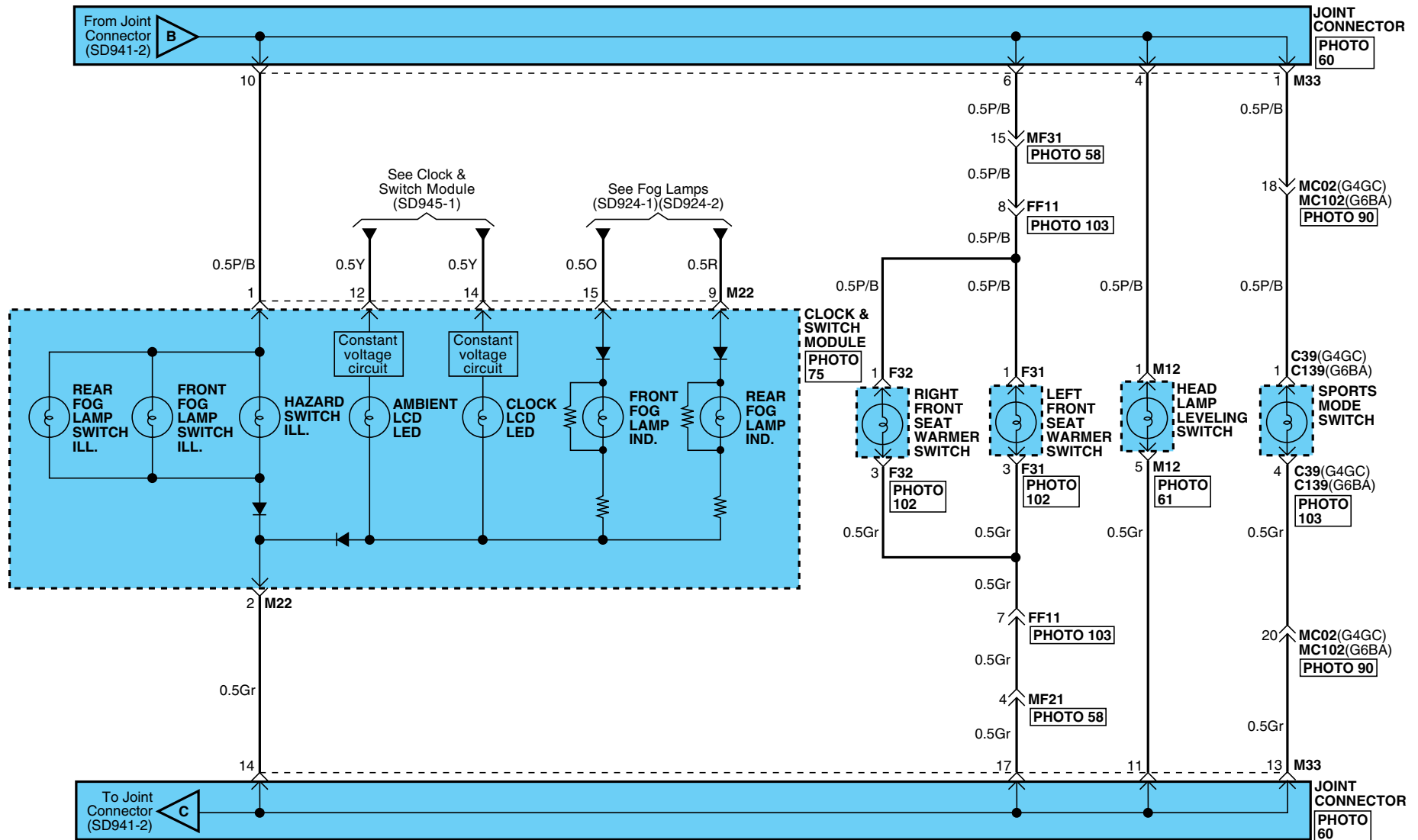
SD941-3

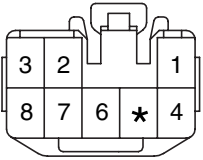
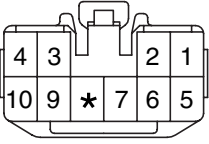
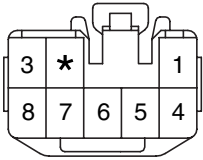
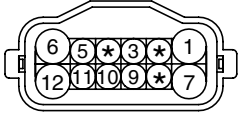
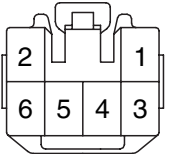
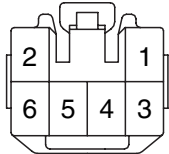
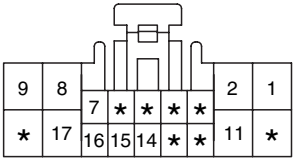
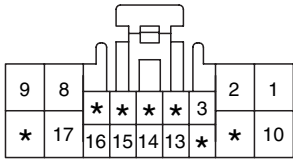
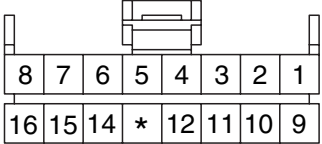
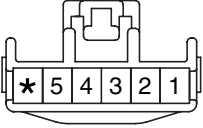
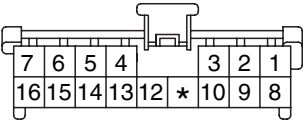
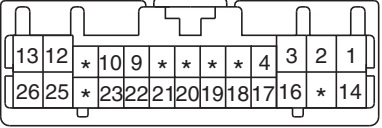
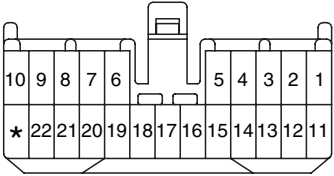
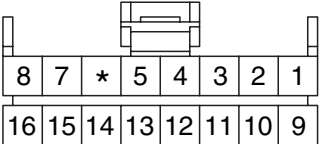
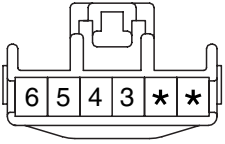
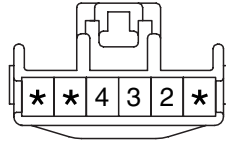
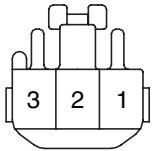
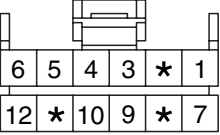
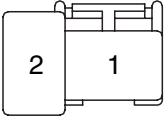

ILLUMINATIONS

ILLUMINATIONS (4)			SD941-4
<p>C39/C139</p>  <p>KET_090II_08F_W</p>	<p>D05</p>  <p>KET_090II_10F_W</p>	<p>D15</p>  <p>KET_090II_08F_W</p>	<p>E57</p>  <p>KET_1809WP_12F_Gr</p>
<p>F31</p>  <p>KET_090II_06F_L</p>	<p>F32</p>  <p>KET_090II_06F_W</p>	<p>M01-2</p>  <p>KET_0509_18F_W</p>	<p>M02-2</p>  <p>KET_0509_18F_W</p>
<p>M10-2</p>  <p>AMP_040M1_16F_B</p>	<p>M12</p>  <p>KET_090II_06F_W_SW</p>	<p>M16-1</p>  <p>KUM_AR_16F_W</p>	<p>M19-1</p>  <p>KET_0407_26F_W</p>
<p>M20</p>  <p>KET_050_23F_W</p>	<p>M22</p>  <p>AMP_040M1_16F_B</p>	<p>M23</p>  <p>KET_090II_06F_B_SW</p>	<p>M29</p>  <p>KET_090II_06F_L_SW</p>
<p>M31</p>  <p>KET_090II_03F_W</p>	<p>M42</p>  <p>AMP_040M1_12F_B</p>	<p>M50</p>  <p>AMP_PLM2_02F_B</p>	<p>M51-1/M51-2</p>  <p>CR01F018</p>

MULTI GAUGE UNIT (1)

SD944-1

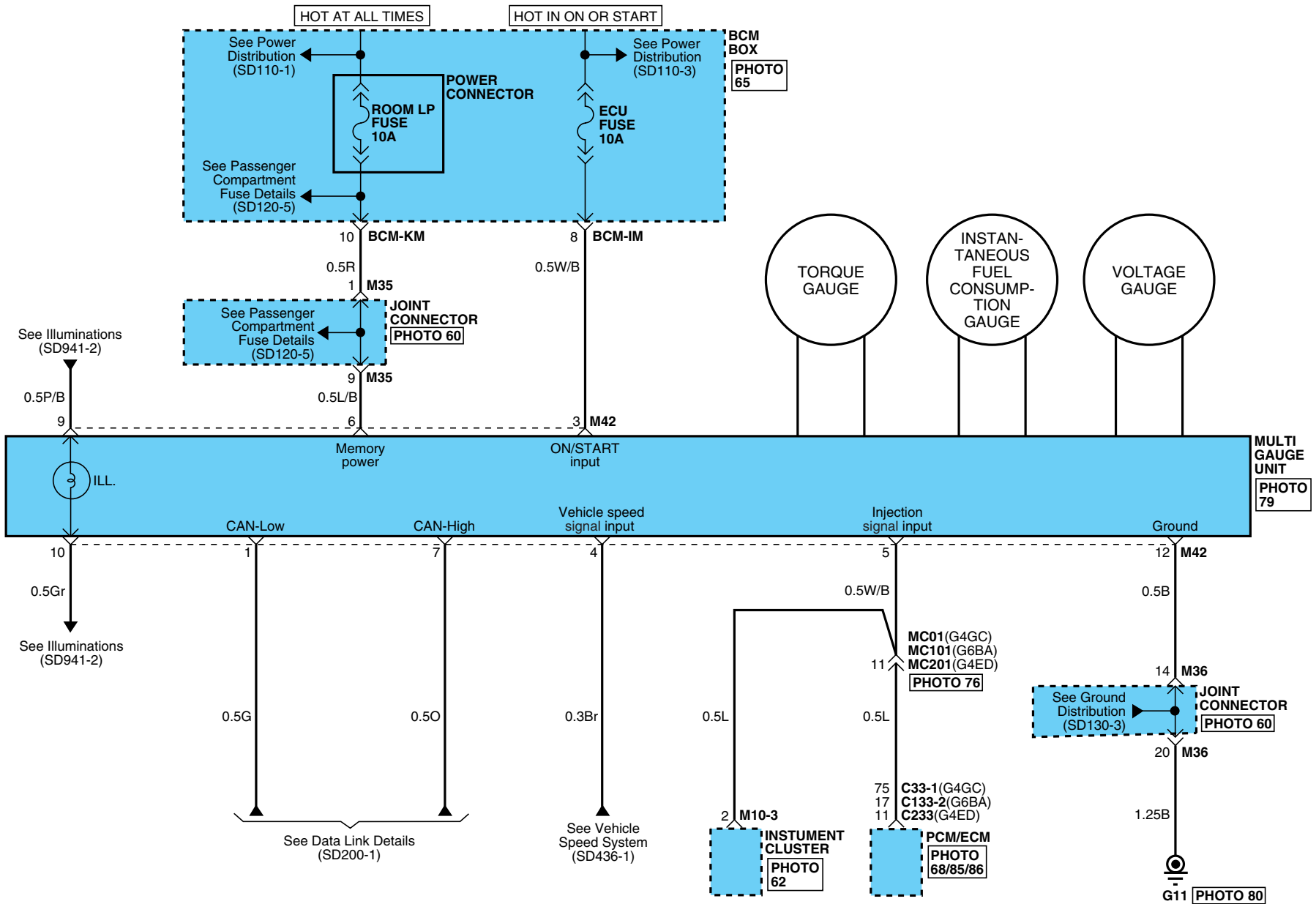

MULTI GAUGE UNIT

MULTI GAUGE UNIT (2)

SD944-2

C33-1

6	7	8	9	10	11	*	*	14	*	*	17	18	*	*	21	22	23	24	5	4	
*	26	27	*	29	30	31	32	*	*	*	*	37	38	39	*	*	42	43	3		
44	45	*	47	48	*	50	51	52	*	54	55	56	*	58	59	60	61	62			
*	64	65	66	67	68	69	70	*	72	73	*	75	76	77	78	*	80	81			

KET_ECU_81F_B_BOSCH

C133-2

24	23	22	21	20	19
18	17	16	15	14	13
*	*	*	*	*	7
*	*	*	*	*	1

AMP_ECU_24F_B_134P

BLANK

C233

6	7	8	*	*	11	12	13	14	15	16	17	18	19	20	*	*	*	24	5	*
*	26	27	28	29	*	31	32	33	34	35	36	37	*	39	*	*	42	*	3	
44	45	46	47	48	49	50	51	52	53	*	55	*	57	*	59	60	61	*		
63	*	*	*	*	68	69	70	71	*	73	74	75	*	*	*	79	80	*		

KET_ECU_81F_B_BOSCH

M10-3

10	9	8	7	6	5	4	3	2	1
20	19	18	17	*	15	14	13	12	11

AMP_040M1_20F_B

M42

6	5	4	3	*	1
12	*	10	9	*	7

AMP_040M1_12F_B

CLOCK & SWITCH MODULE (1)

SD945-1

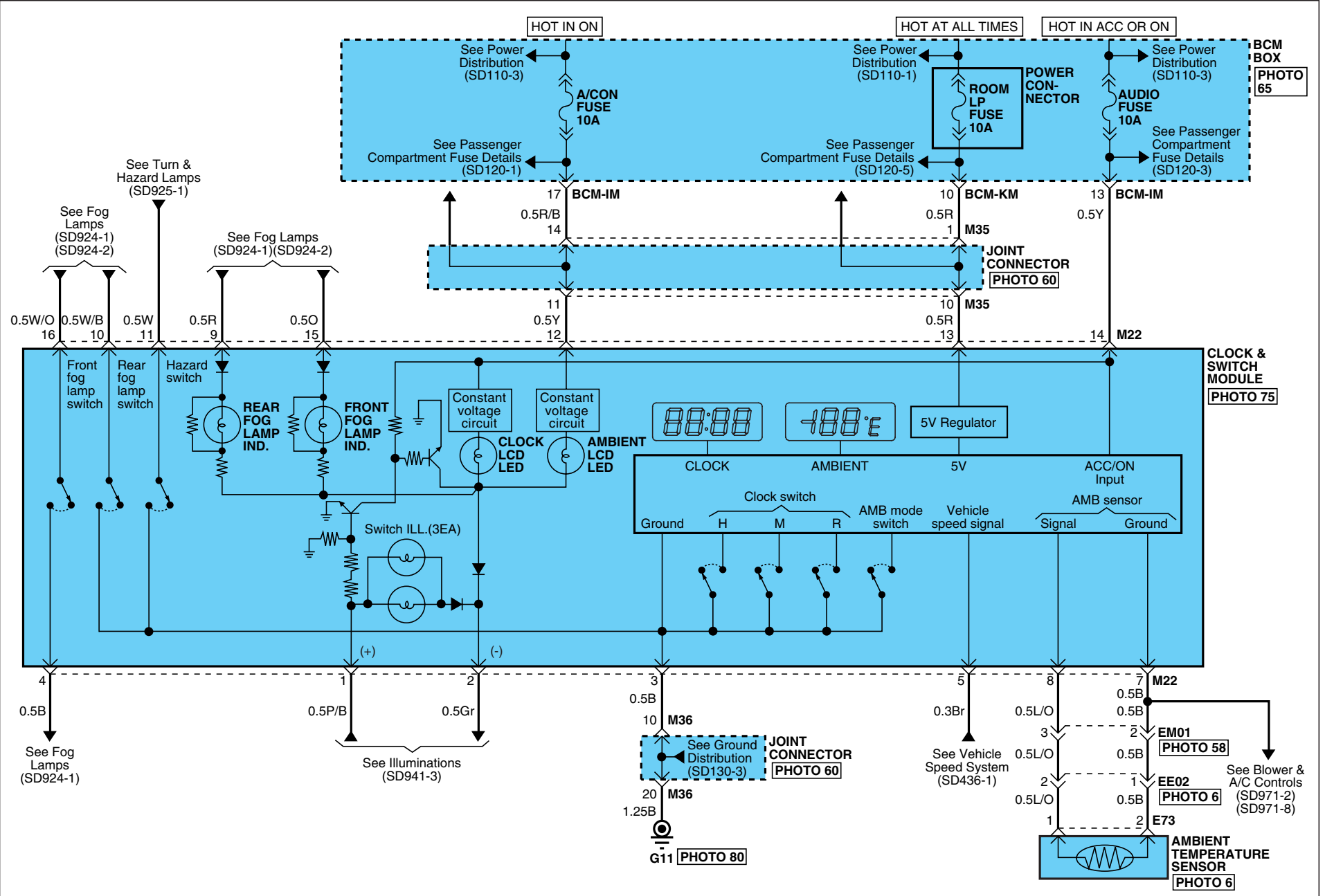

CLOCK & SWITCH MODULE

CLOCK & SWITCH MODULE (2)

SD945-2

E73

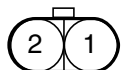

CR02F001

M22

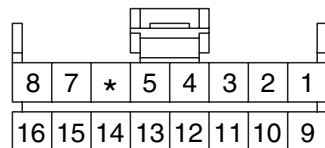

AMP_040M1_16F_B

BLANK

BLANK

BCM (BODY CONTROL MODULE) SYSTEM (1)

SD950-1

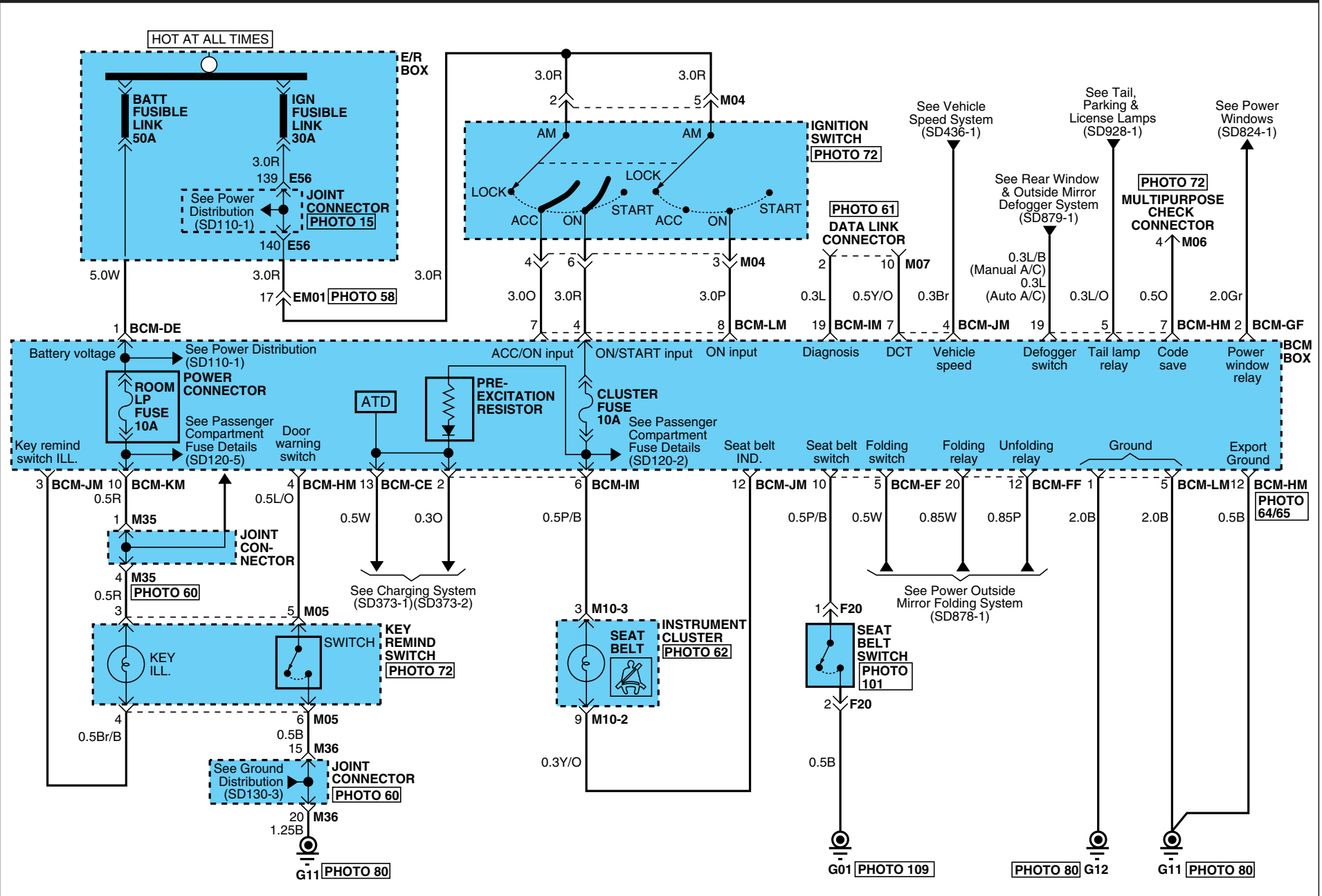

BCM (BODY CONTROL MODULE) SYSTEM

BCM (BODY CONTROL MODULE) SYSTEM (2)

SD950-2

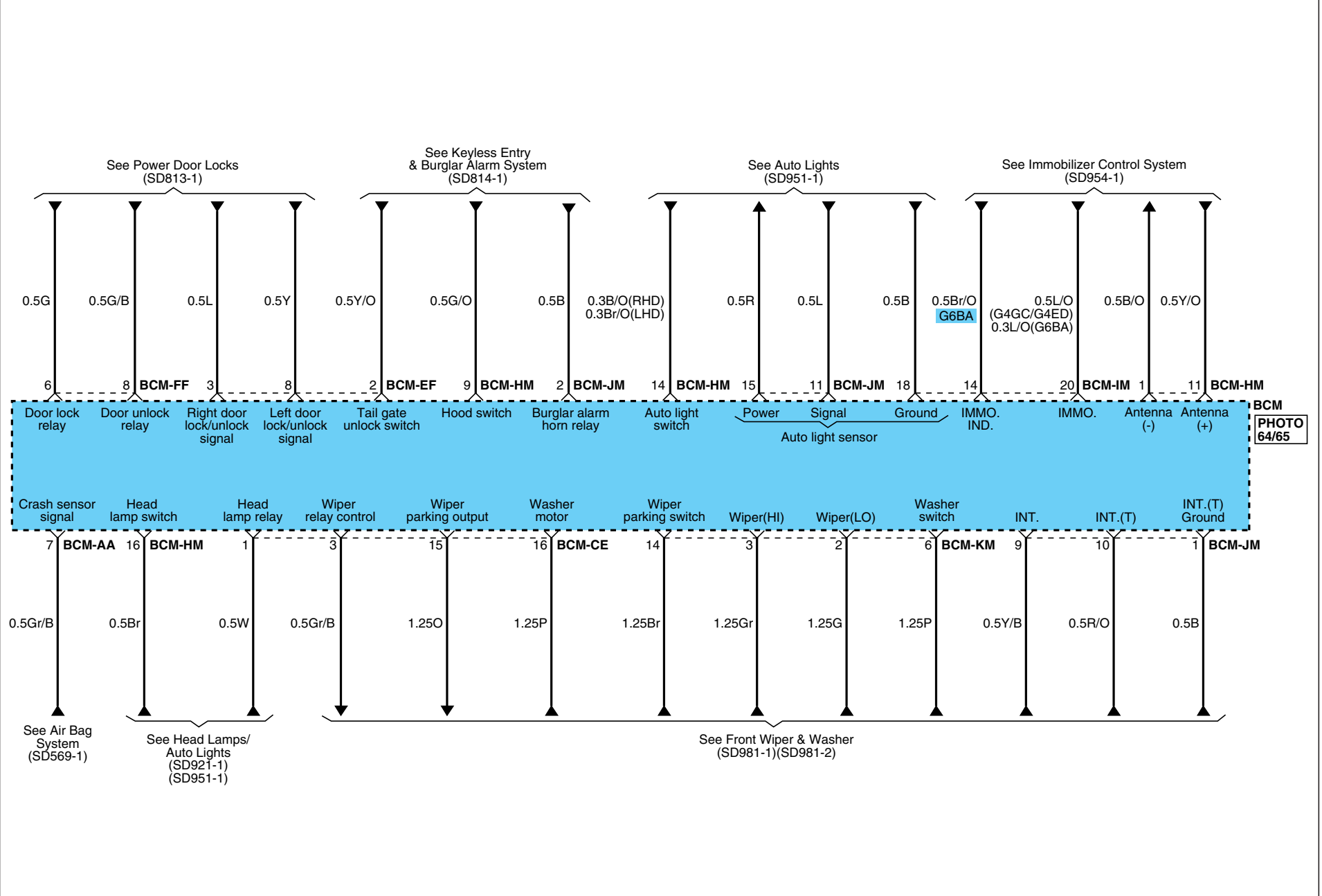

BCM (BODY CONTROL MODULE) SYSTEM

BCM (BODY CONTROL MODULE) SYSTEM (3)



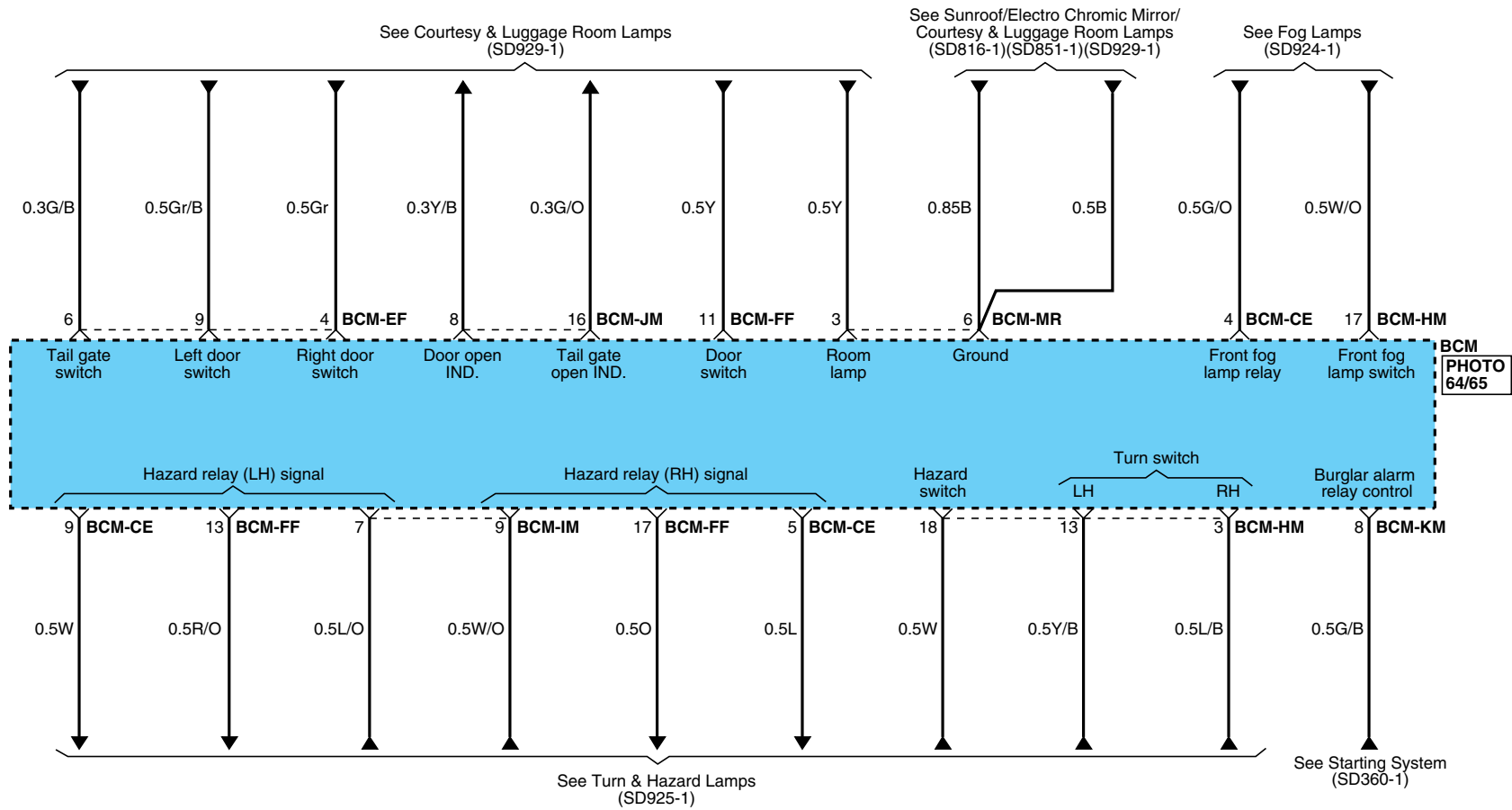

SD950-3

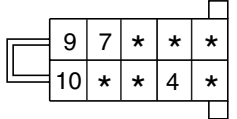
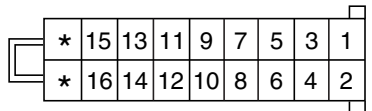

BCM (BODY CONTROL MODULE) SYSTEM

BCM (BODY CONTROL MODULE) SYSTEM (4)

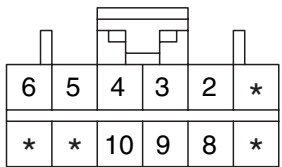
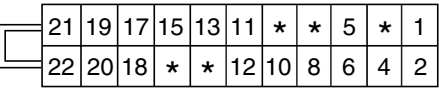
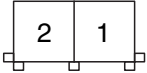
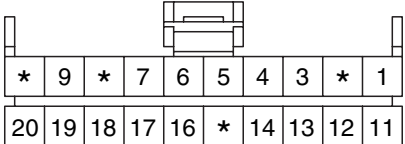
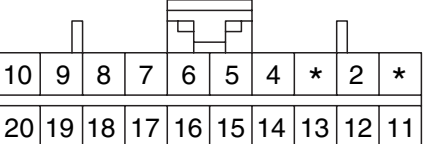
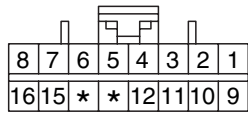
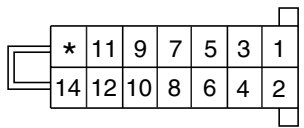
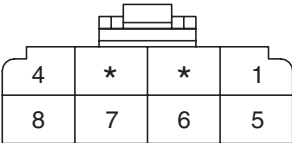
SD950-4

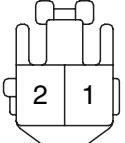
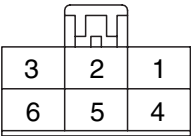
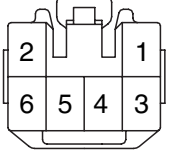
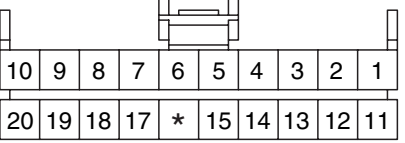
<p>BCM-AA</p>  <p>AMP_JPT_10F_B</p>	<p>BCM-CE</p>  <p>AMP_JPT_18F_B</p>	<p>BCM-DE</p>  <p>AMP_250DL_01F_B</p>	<p>BCM-EF</p>  <p>AMP_040M2_12F_B</p>
<p>BCM-FF</p>  <p>AMP_JPT_22F_B</p>	<p>BCM-GF</p>  <p>AMP_SPT_02F_B</p>	<p>BCM-HM</p>  <p>AMP_040M1_20F_B</p>	<p>BCM-IM</p>  <p>AMP_040M2_20F_B</p>
<p>BCM-JM</p>  <p>AMP_040M2_16F_B</p>	<p>BCM-KM</p>  <p>AMP_JPT_14F_B</p>	<p>BCM-LM</p>  <p>AMP_250_08F_W</p>	<p>BCM-MR</p>  <p>AMP_JPT_08F_B</p>
<p>F20</p>  <p>KET_090II_02F_W_L</p>	<p>M04</p>  <p>KUM_DSD_06F_W</p>	<p>M05</p>  <p>KET_090II_06F_W</p>	<p>M10-3</p>  <p>AMP_040M1_20F_B</p>

AUTO LIGHTS (1)

SD951-1

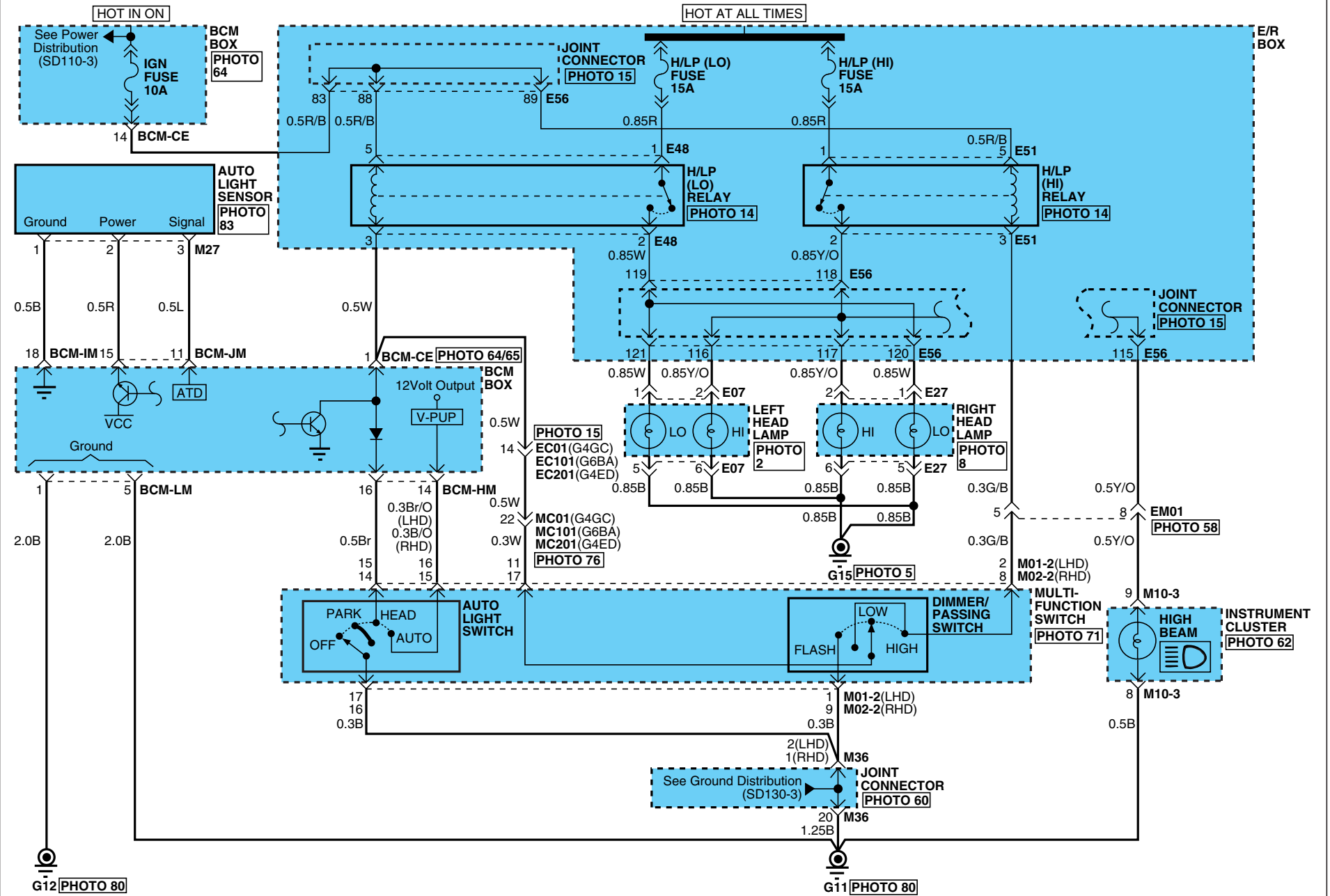

AUTO LIGHTS

AUTO LIGHTS (2)

SD951-2

E07

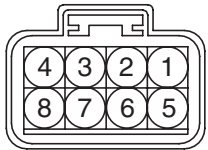

KUM_NMWP_08F_B

E27

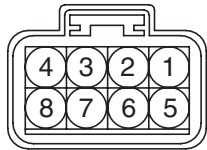

KUM_NMWP_08F_B

E48

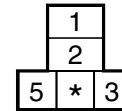

CR05F011

E51

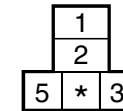

CR05F011

M01-2

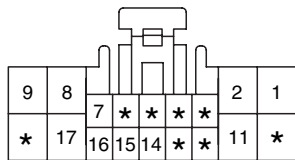

KET_0509_18F_W

M02-2

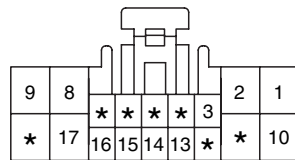

KET_0509_18F_W

M10-3

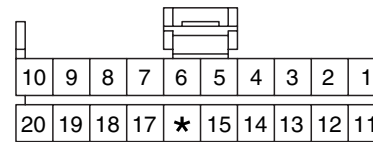

AMP_040M1_20F_B

M27

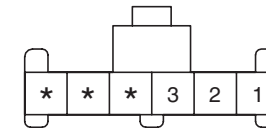

KET_91A_06F_W

IMMOBILIZER CONTROL SYSTEM

IMMOBILIZER CONTROL SYSTEM (2)

SD954-2

C33-1

6	7	8	9	10	11	*	*	14	*	*	17	18	*	*	21	22	23	24	5	4
*	26	27	*	29	30	31	32	*	*	*	*	37	38	39	*	*	42	43	3	
44	45	*	47	48	*	50	51	52	*	54	55	56	*	58	59	60	61	62		
*	64	65	66	67	68	69	70	*	72	73	*	75	76	77	78	*	80	81	2	1

KET_ECU_81F_B_BOSCH

C133-1

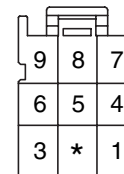

AMP_ECU_09F_B_134P

C136-3

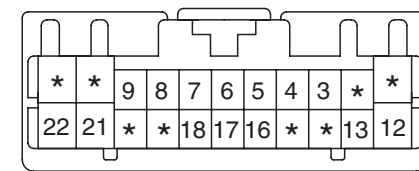

KET_0407_22F_W

C233

6	7	8	*	*	11	12	13	14	15	16	17	18	19	20	*	*	*	24	5	*
*	26	27	28	29	*	31	32	33	34	35	36	37	*	39	*	*	42	*	3	
44	45	46	47	48	49	50	51	52	53	*	55	*	57	*	59	60	61	*		
63	*	*	*	*	68	69	70	71	*	73	74	75	*	*	*	79	80	*	2	*

KET_ECU_81F_B_BOSCH

M05

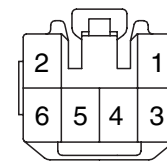

KET_090II_06F_W

M06

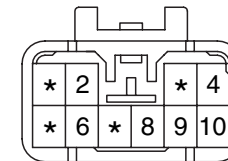

KET_090II_10M_W

M07

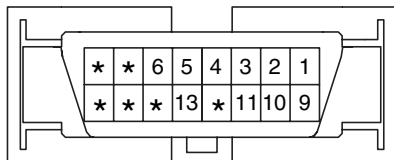

MLX_OBDII_16F_B_SIN

M10-2

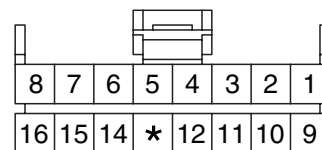

AMP_040M1_16F_B

BLANK

BLANK

DAYTIME RUNNING LIGHTS (1)

SD958-1

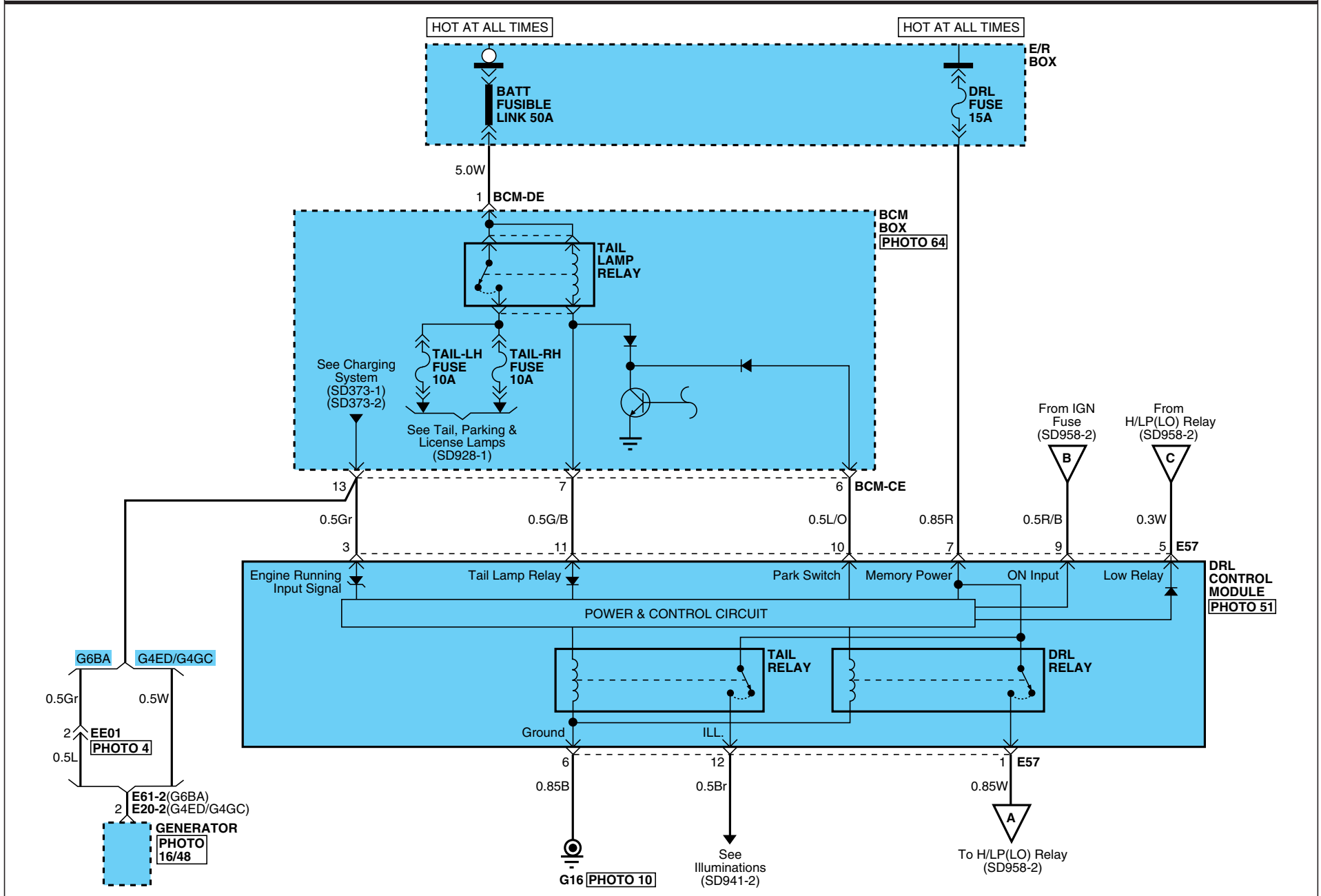

DAYTIME RUNNING LIGHTS

DAYTIME RUNNING LIGHTS (2)

SD958-2

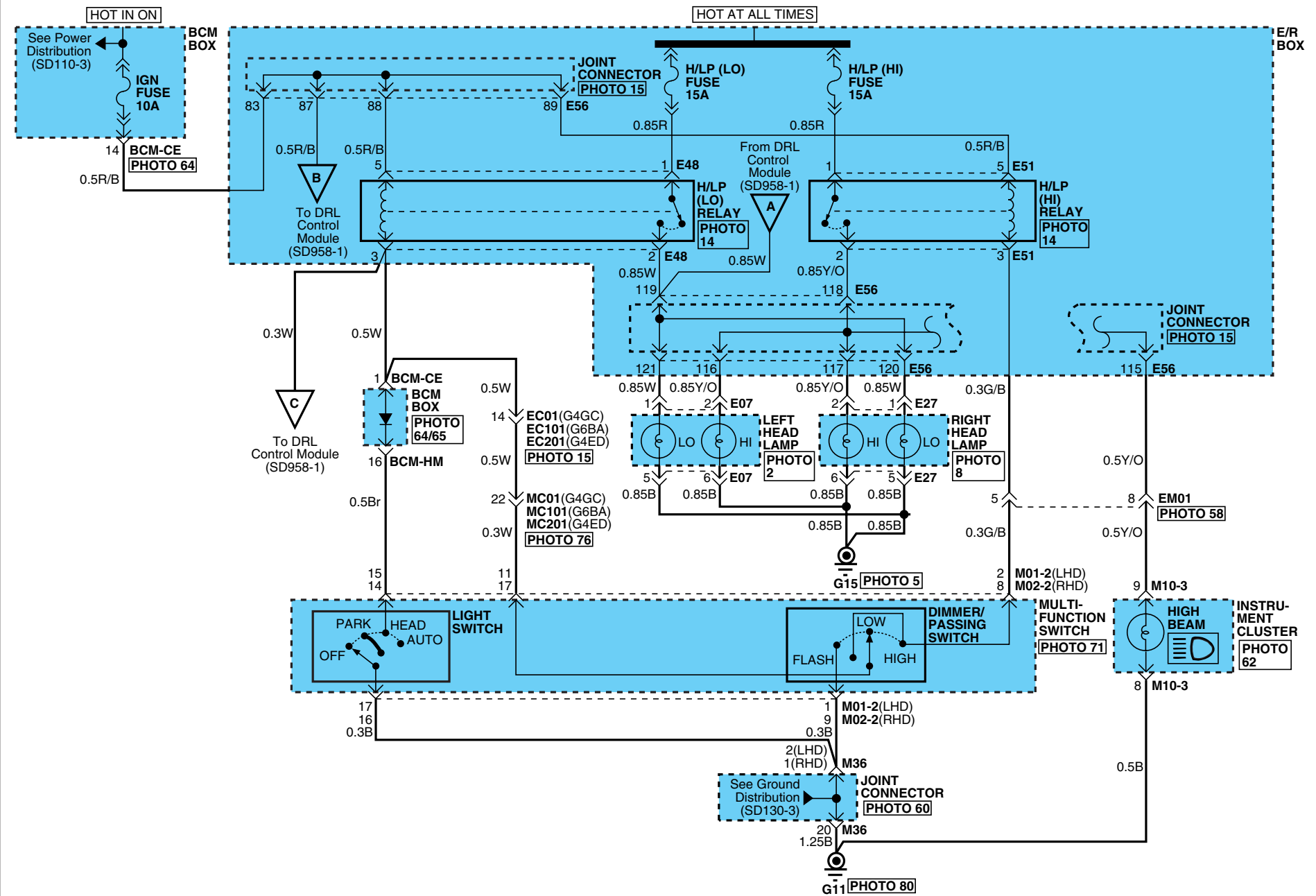

DAYTIME RUNNING LIGHTS

DAYTIME RUNNING LIGHTS (3)

SD958-3

E07

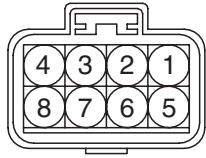

KUM_NMWP_08F_B

E20-2

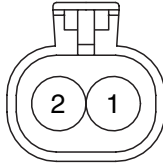

KET_58X_02F_B

E27

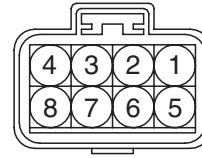

KUM_NMWP_08F_B

E48

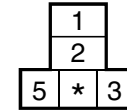

CR05F011

E51

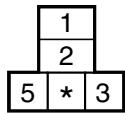

CR05F011

E57

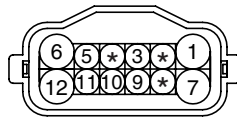

KET_1809WP_12F_Gr

E61-2

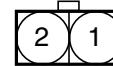

CR02F002

M01-2

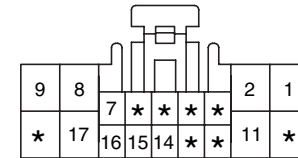

KET_0509_18F_W

M02-2

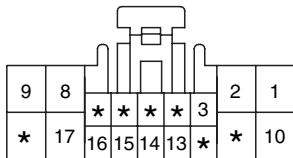

KET_0509_18F_W

M10-3

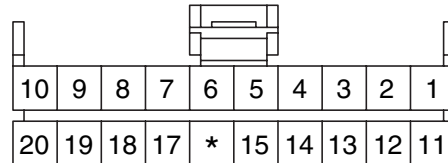

AMP_040M1_20F_B

BLANK

BLANK

DAYTIME RUNNING LIGHTS

DAYTIME RUNNING LIGHTS (4)

SD958-4

MEMO

AUDIO SYSTEM (1)

SD961-1

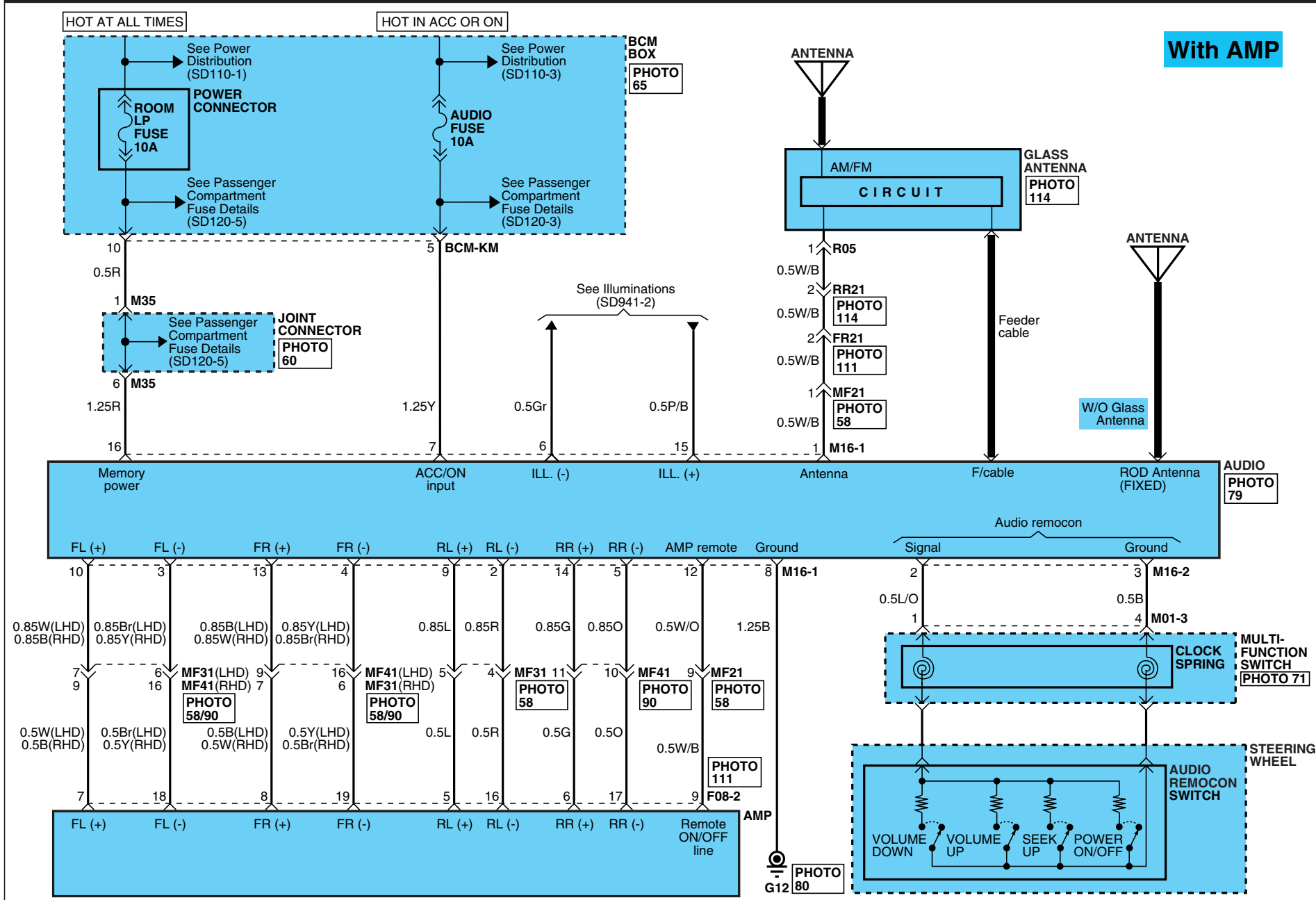

AUDIO SYSTEM

AUDIO SYSTEM (2)

SD961-2

HOT AT ALL TIMES

With AMP

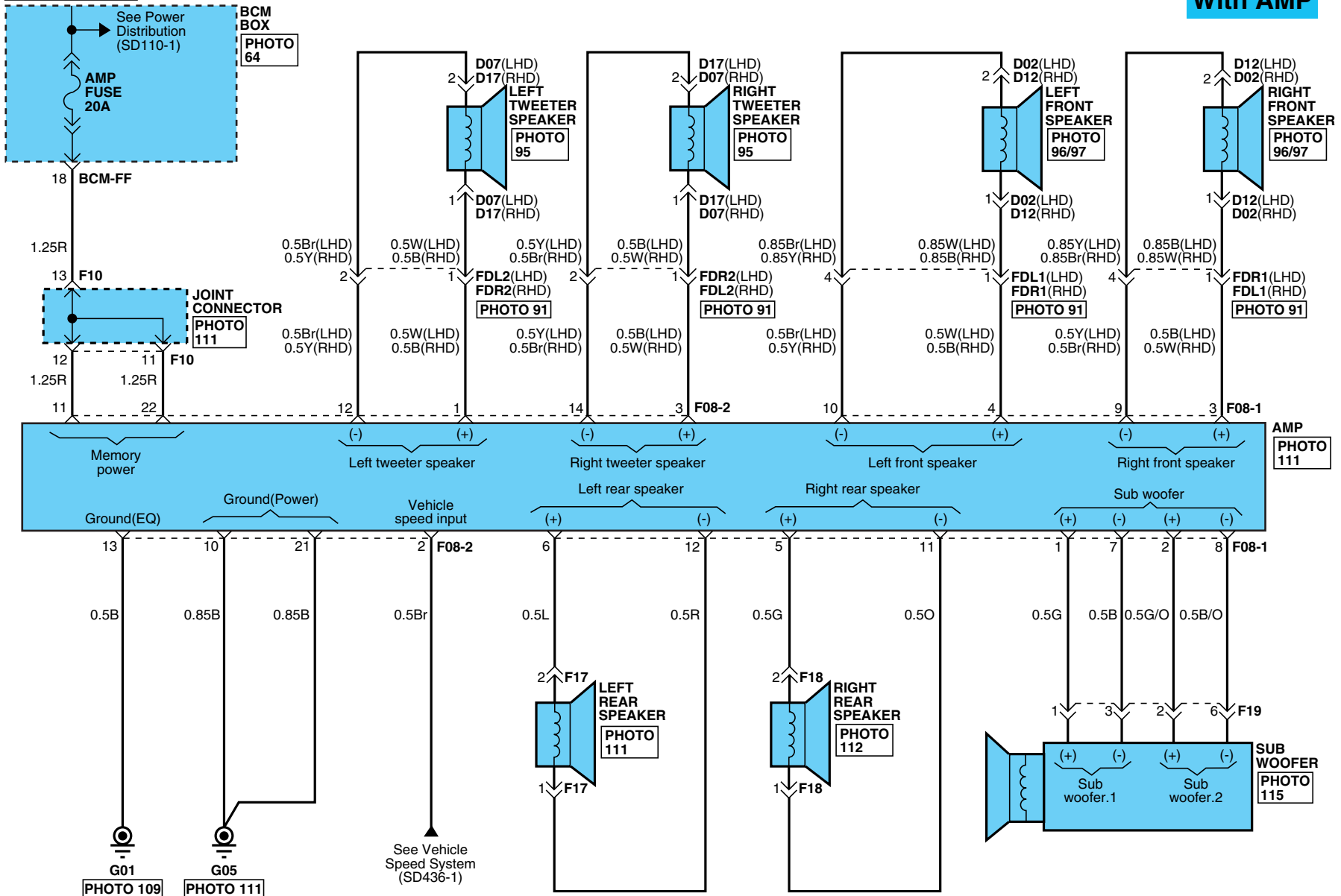

AUDIO SYSTEM

AUDIO SYSTEM (3)

SD961-3

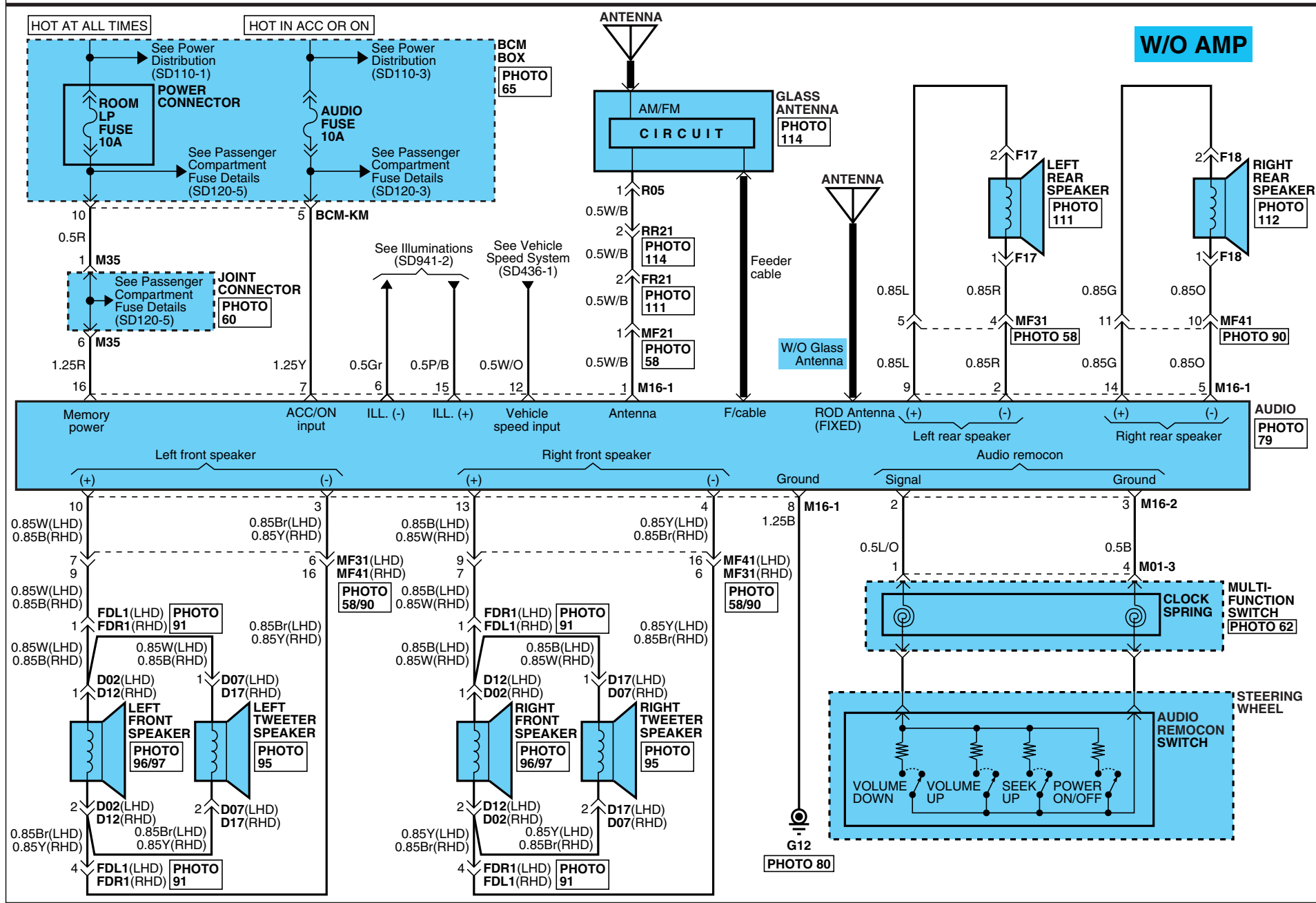

AUDIO SYSTEM

AUDIO SYSTEM (4)

SD961-4

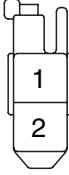
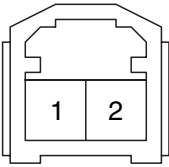
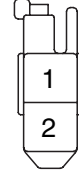
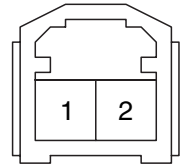
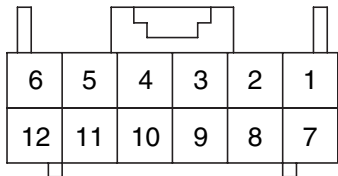
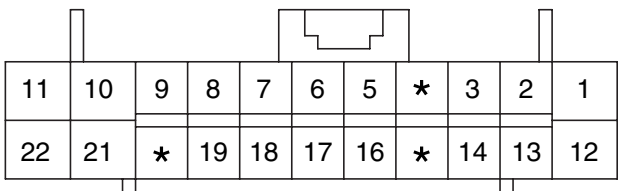
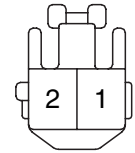
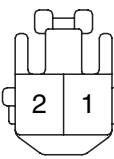
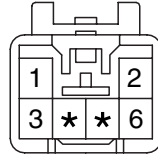
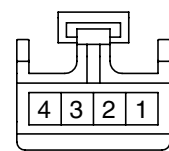
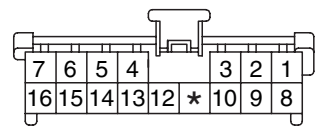
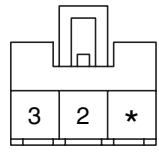
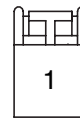
<p>D02</p>  <p>KET_090II_02F_W_SPK</p>	<p>D07</p>  <p>AMP_070_02M_W</p>	<p>D12</p>  <p>KET_090II_02F_W_SPK</p>	<p>D17</p>  <p>AMP_070_02M_W</p>
<p>F08-1</p>  <p>AMP_0407_12F_W_070</p>	<p>F08-2</p>  <p>AMP_0407_22F_W_HD</p>		<p>F17</p>  <p>KET_090II_02F_W_L</p>
<p>F18</p>  <p>KET_090II_02F_W_L</p>	<p>F19</p>  <p>KET_090II_06M_W</p>	<p>M01-3</p>  <p>FUR_FA_04F_B_AB</p>	<p>M16-1</p>  <p>KUM_AR_16F_W</p>
<p>M16-2</p>  <p>KUM_CDR_03F_W</p>	<p>R05</p>  <p>AMP_PLM2_01F_187</p>	<p>BLANK</p>	<p>BLANK</p>

AUTO CRUISE CONTROL SYSTEM (G4GC/G6BA) (1)

SD964-1

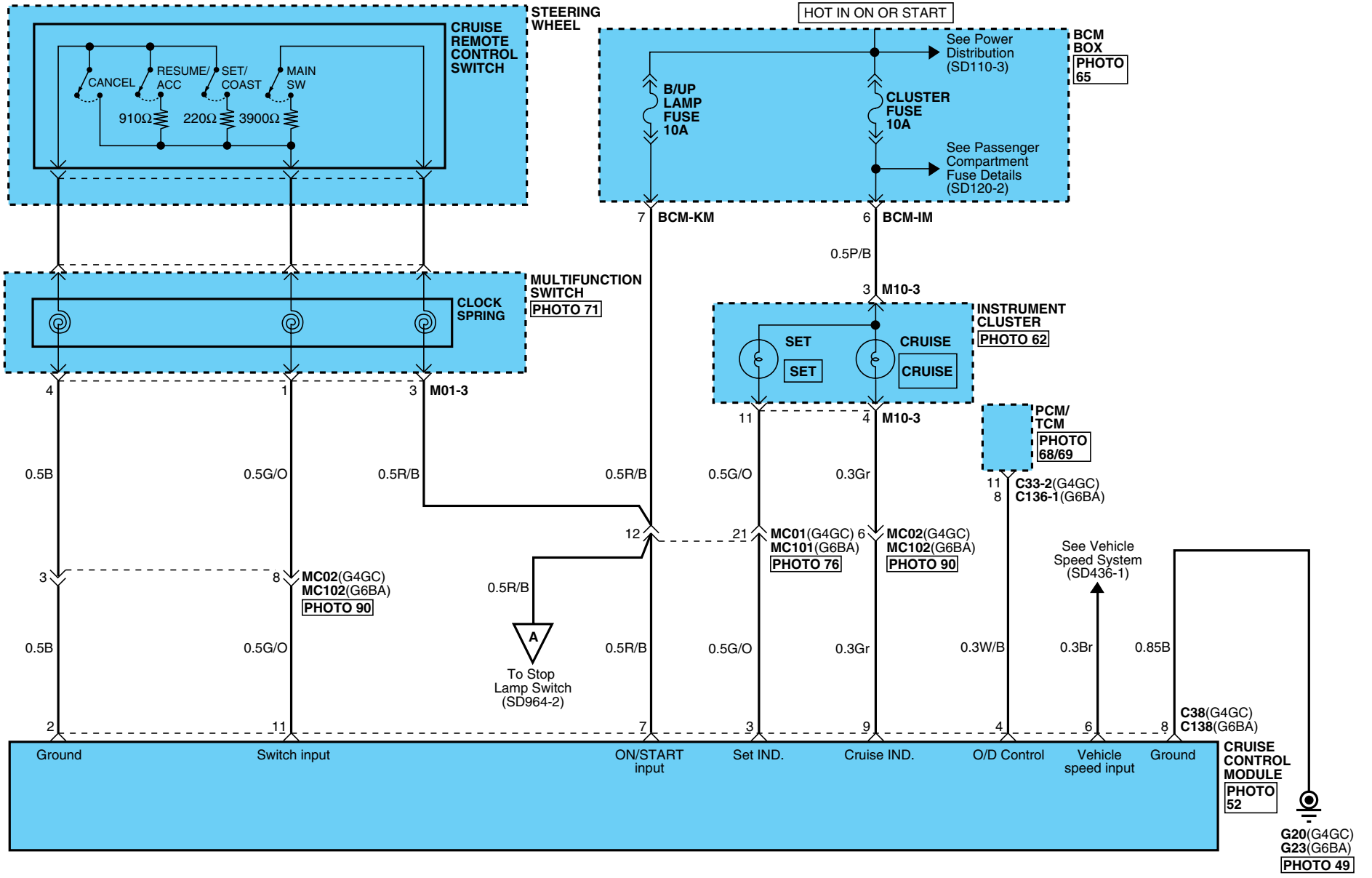

G20(G4GC)
G23(G6BA)
PHOTO 49

AUTO CRUISE CONTROL SYSTEM

AUTO CRUISE CONTROL SYSTEM (G4GC/G6BA) (3)

SD964-3

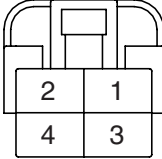
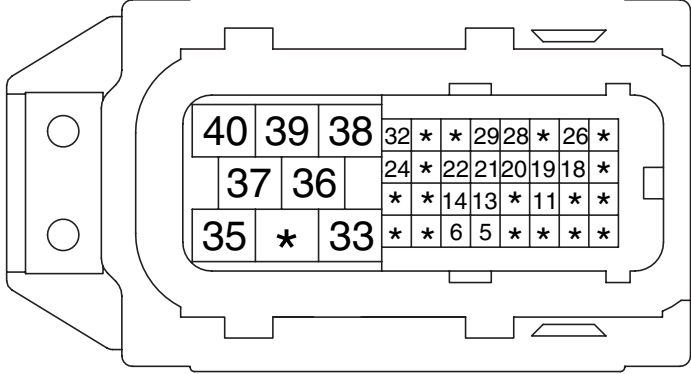
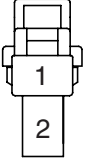
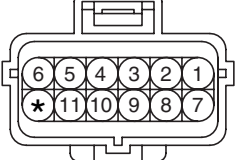
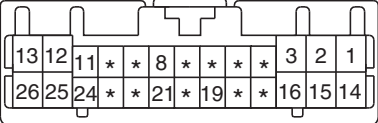
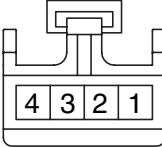
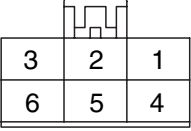
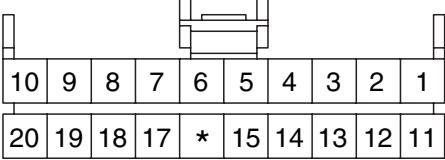
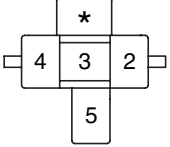
<p>C01/C101</p>  <p>KET_SSD_10F_B_A</p>	<p>C32/C132</p>  <p>KET_250DL_04F_W</p>	<p>C33-2</p>  <p>KET_ECU_40F_B</p>	
<p>C35/C135</p>  <p>KET_250DL_02F_W</p>	<p>C38/C138</p>  <p>AMP_EJWP_12F_B</p>		
<p>C136-1</p>  <p>KET_0407_26F_W</p>	<p>M01-3</p>  <p>FUR_FA_04F_B_AB</p>	<p>M04</p>  <p>KUM_DSD_06F_W</p>	<p>M10-3</p>  <p>AMP_040M1_20F_B</p>
<p>M41</p>  <p>KET_250_05F_B_RLY</p>	<p>BLANK</p>	<p>BLANK</p>	<p>BLANK</p>

AUTO CRUISE CONTROL SYSTEM

AUTO CRUISE CONTROL SYSTEM (G4GC/G6BA) (4)

SD964-4

MEMO

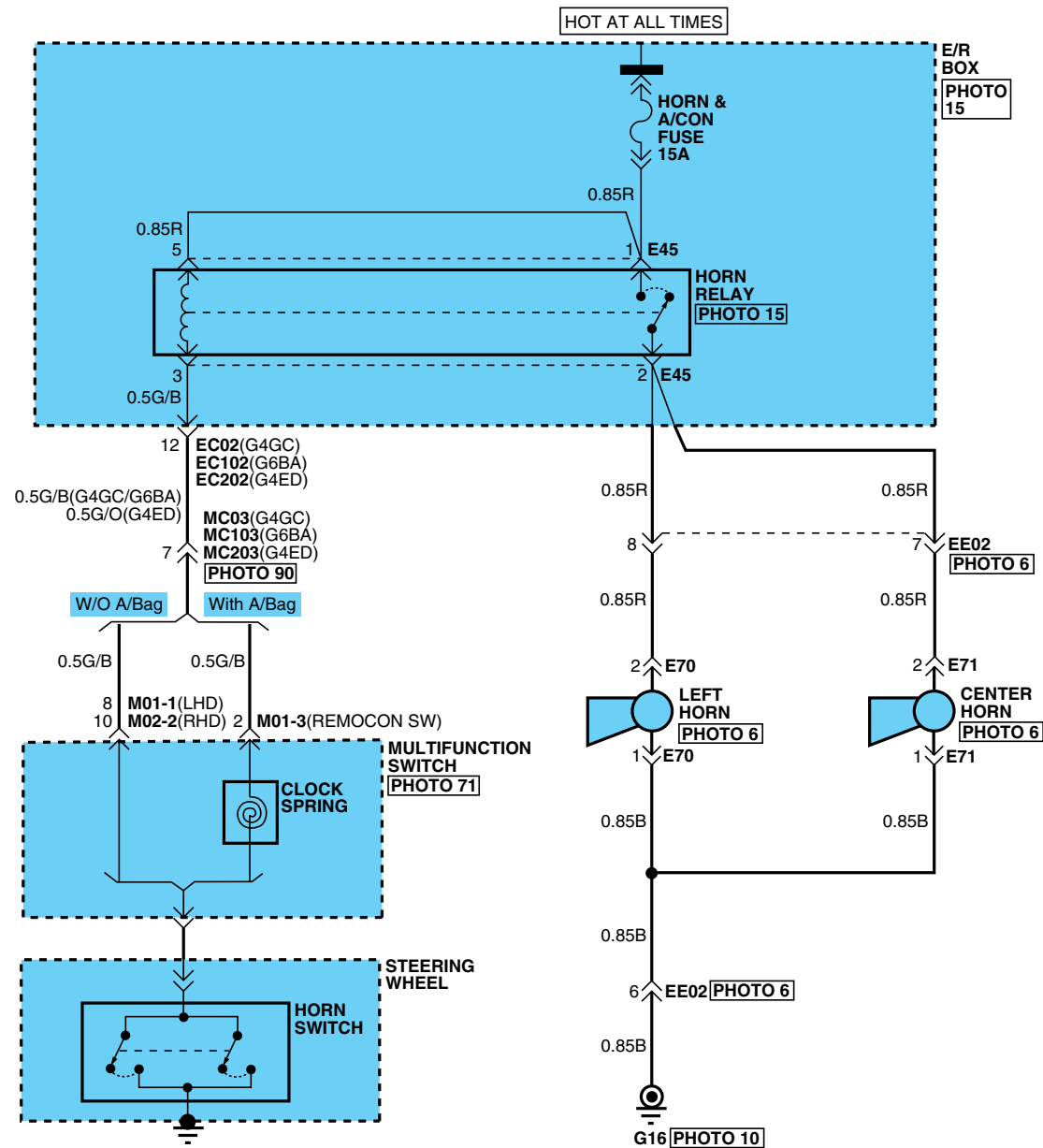

HORNS

HORNS (2)

SD968-2

E45

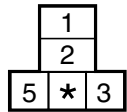

CR05F011

E70

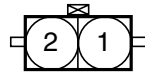

CR02F091

E71

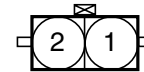

CR02F091

M01-1

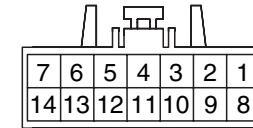

KET_090II_14F_W_SW

M01-3

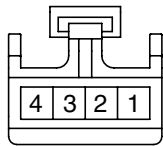

FUR_FA_04F_B_AB

M02-2

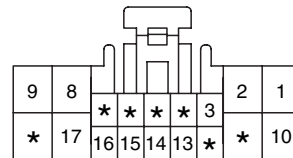

KET_0509_18F_W

BLANK

BLANK

BLOWER & A/C CONTROLS (AUTO) (1)

SD971-1

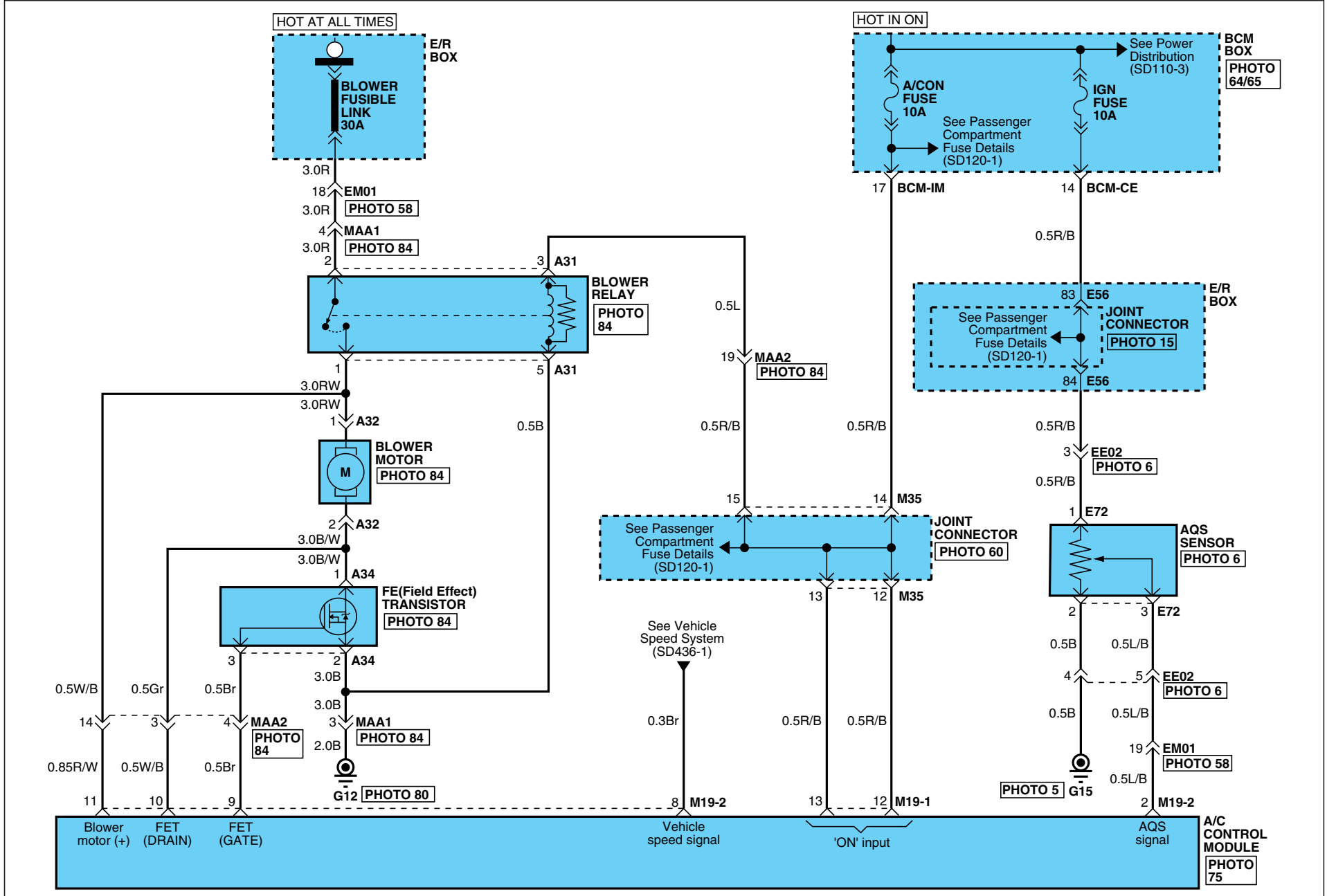

BLOWER & A/C CONTROLS

BLOWER & A/C CONTROLS (AUTO) (2)

SD971-2

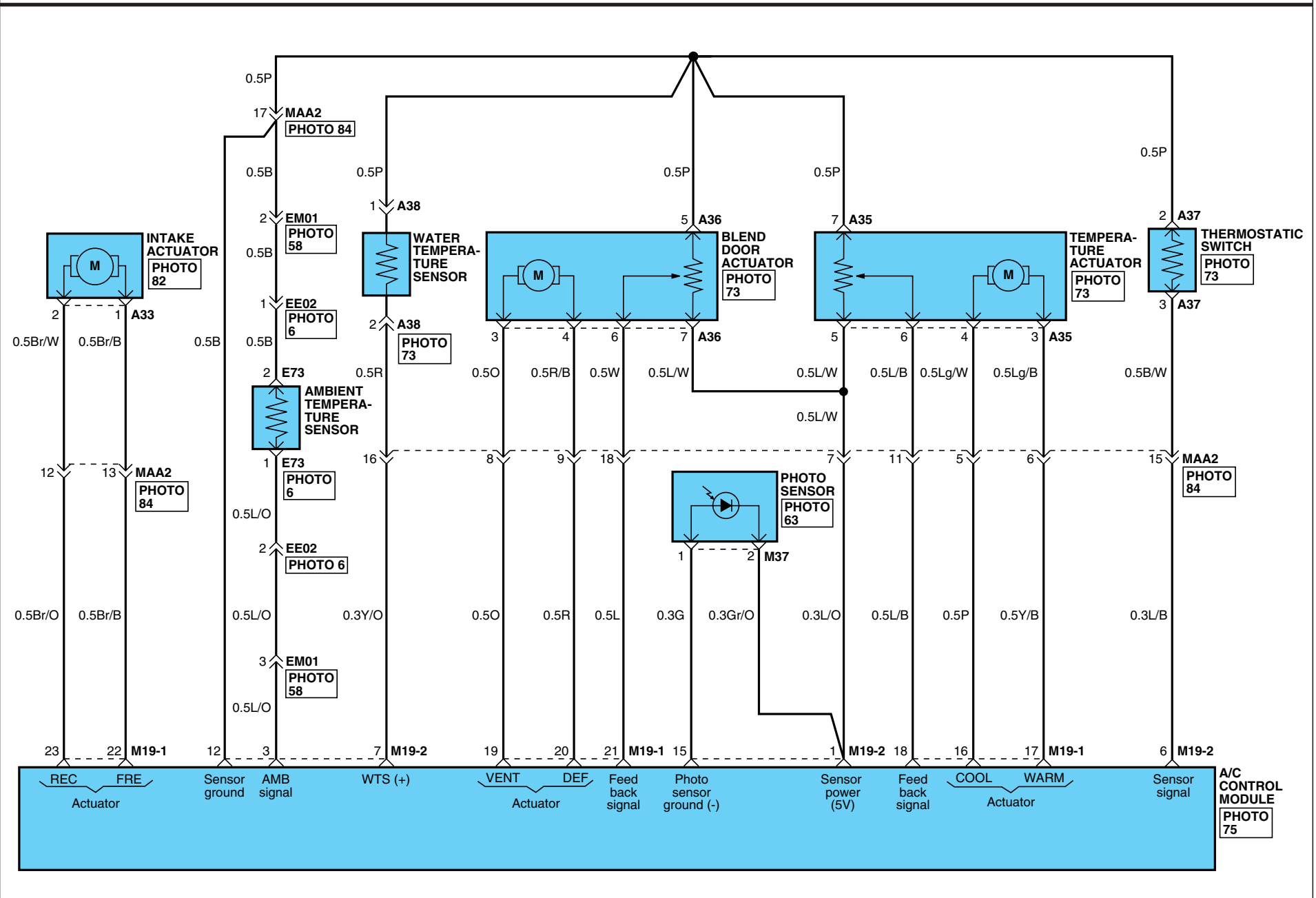

BLOWER & A/C CONTROLS

BLOWER & A/C CONTROLS (AUTO) (3)



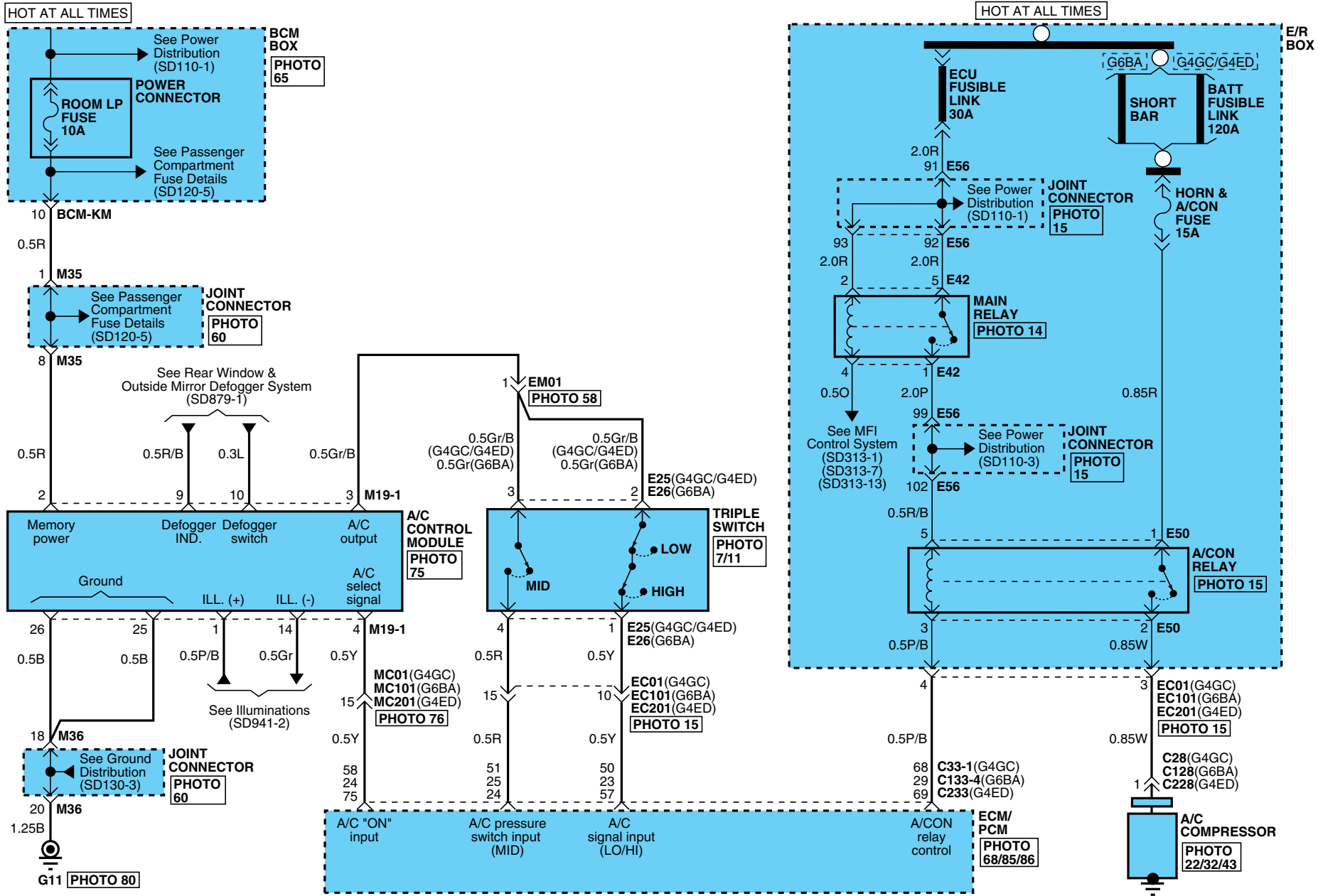



SD971-3

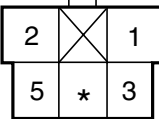
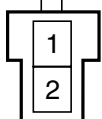
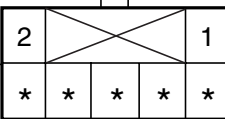
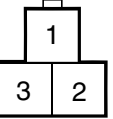
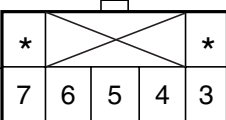
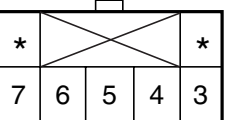
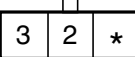
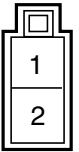

BLOWER & A/C CONTROLS

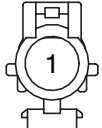
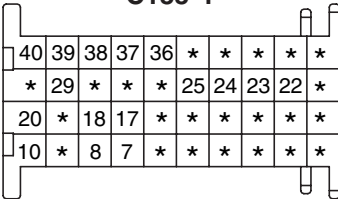
BLOWER & A/C CONTROLS (AUTO) (4)

SD971-4

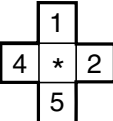
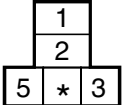
<p>A31</p>  <p>CR05F026</p>	<p>A32</p>  <p>CR02M042</p>	<p>A33</p>  <p>CR07F011</p>	<p>A34</p>  <p>CR03F005</p>																																																																																		
<p>A35</p>  <p>CR07F011</p>	<p>A36</p>  <p>CR07F011</p>	<p>A37</p>  <p>CR03F040</p>	<p>A38</p>  <p>CR02M033</p>																																																																																		
<p>C28</p>  <p>KUM_NMWP_01F_B</p>	<p>C33-1</p> <table border="1" data-bbox="705 782 1534 941"> <tr> <td>6</td><td>7</td><td>8</td><td>9</td><td>10</td><td>11</td><td>*</td><td>*</td><td>14</td><td>*</td><td>*</td><td>17</td><td>18</td><td>*</td><td>*</td><td>21</td><td>22</td><td>23</td><td>24</td><td>5</td><td>4</td> </tr> <tr> <td>*</td><td>26</td><td>27</td><td>*</td><td>29</td><td>30</td><td>31</td><td>32</td><td>*</td><td>*</td><td>*</td><td>*</td><td>37</td><td>38</td><td>39</td><td>*</td><td>*</td><td>42</td><td>43</td><td colspan="2" rowspan="2">3</td> </tr> <tr> <td>44</td><td>45</td><td>*</td><td>47</td><td>48</td><td>*</td><td>50</td><td>51</td><td>52</td><td>*</td><td>54</td><td>55</td><td>56</td><td>*</td><td>58</td><td>59</td><td>60</td><td>61</td><td>62</td> </tr> <tr> <td>*</td><td>64</td><td>65</td><td>66</td><td>67</td><td>68</td><td>69</td><td>70</td><td>*</td><td>72</td><td>73</td><td>*</td><td>75</td><td>76</td><td>77</td><td>78</td><td>*</td><td>80</td><td>81</td><td>2</td><td>1</td> </tr> </table> <p>KET_ECU_81F_B_BOSCH</p>		6	7	8	9	10	11	*	*	14	*	*	17	18	*	*	21	22	23	24	5	4	*	26	27	*	29	30	31	32	*	*	*	*	37	38	39	*	*	42	43	3		44	45	*	47	48	*	50	51	52	*	54	55	56	*	58	59	60	61	62	*	64	65	66	67	68	69	70	*	72	73	*	75	76	77	78	*	80	81	2	1	<p>C128</p>  <p>KET_SWP_01F_B</p>
6	7	8	9	10	11	*	*	14	*	*	17	18	*	*	21	22	23	24	5	4																																																																	
*	26	27	*	29	30	31	32	*	*	*	*	37	38	39	*	*	42	43	3																																																																		
44	45	*	47	48	*	50	51	52	*	54	55	56	*	58	59	60	61	62																																																																			
*	64	65	66	67	68	69	70	*	72	73	*	75	76	77	78	*	80	81	2	1																																																																	
<p>C133-4</p>  <p>AMP_ECU_40F_B_134P</p>	<p>C228</p>  <p>KUM_NMWP_01F_B</p>	<p>C233</p> <table border="1" data-bbox="1176 1053 2004 1212"> <tr> <td>6</td><td>7</td><td>8</td><td>*</td><td>*</td><td>11</td><td>12</td><td>13</td><td>14</td><td>15</td><td>16</td><td>17</td><td>18</td><td>19</td><td>20</td><td>*</td><td>*</td><td>*</td><td>24</td><td>5</td><td>*</td> </tr> <tr> <td>*</td><td>26</td><td>27</td><td>28</td><td>29</td><td>*</td><td>31</td><td>32</td><td>33</td><td>34</td><td>35</td><td>36</td><td>37</td><td>*</td><td>39</td><td>*</td><td>*</td><td>42</td><td>*</td><td colspan="2" rowspan="2">3</td> </tr> <tr> <td>44</td><td>45</td><td>46</td><td>47</td><td>48</td><td>49</td><td>50</td><td>51</td><td>52</td><td>53</td><td>*</td><td>55</td><td>*</td><td>57</td><td>*</td><td>59</td><td>60</td><td>61</td><td>*</td> </tr> <tr> <td>63</td><td>*</td><td>*</td><td>*</td><td>*</td><td>68</td><td>69</td><td>70</td><td>71</td><td>*</td><td>73</td><td>74</td><td>75</td><td>*</td><td>*</td><td>*</td><td>79</td><td>80</td><td>*</td><td>2</td><td>*</td> </tr> </table> <p>KET_ECU_81F_B_BOSCH</p>		6	7	8	*	*	11	12	13	14	15	16	17	18	19	20	*	*	*	24	5	*	*	26	27	28	29	*	31	32	33	34	35	36	37	*	39	*	*	42	*	3		44	45	46	47	48	49	50	51	52	53	*	55	*	57	*	59	60	61	*	63	*	*	*	*	68	69	70	71	*	73	74	75	*	*	*	79	80	*	2	*
6	7	8	*	*	11	12	13	14	15	16	17	18	19	20	*	*	*	24	5	*																																																																	
*	26	27	28	29	*	31	32	33	34	35	36	37	*	39	*	*	42	*	3																																																																		
44	45	46	47	48	49	50	51	52	53	*	55	*	57	*	59	60	61	*																																																																			
63	*	*	*	*	68	69	70	71	*	73	74	75	*	*	*	79	80	*	2	*																																																																	
<p>E25</p>  <p>AMP_EJWP_04F_B</p>	<p>E26</p>  <p>AMP_EJWP_04F_B</p>	<p>E42</p>  <p>CR05F019</p>	<p>E50</p>  <p>CR05F011</p>																																																																																		

BLOWER & A/C CONTROLS

BLOWER & A/C CONTROLS (AUTO) (5)

SD971-5

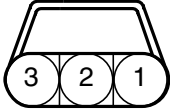
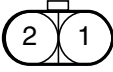
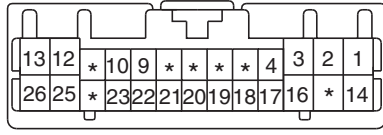
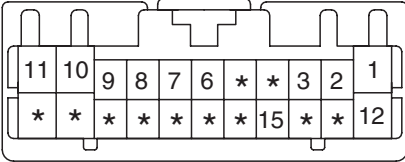
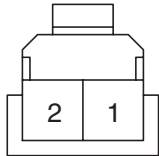
<p style="text-align: center;">E72</p>  <p style="text-align: right; font-size: small;">CR03F070</p>	<p style="text-align: center;">E73</p>  <p style="text-align: right; font-size: small;">CR02F001</p>	<p style="text-align: center;">M19-1</p>  <p style="text-align: right; font-size: small;">KET_0407_26F_W</p>	<p style="text-align: center;">M19-2</p>  <p style="text-align: right; font-size: small;">KET_0407_22F_W</p>
<p style="text-align: center;">M37</p>  <p style="text-align: right; font-size: small;">AMP_070_02F_W</p>	<p>BLANK</p>	<p>BLANK</p>	<p>BLANK</p>

BLOWER & A/C CONTROLS

BLOWER & A/C CONTROLS (AUTO) (6)

SD971-6

MEMO

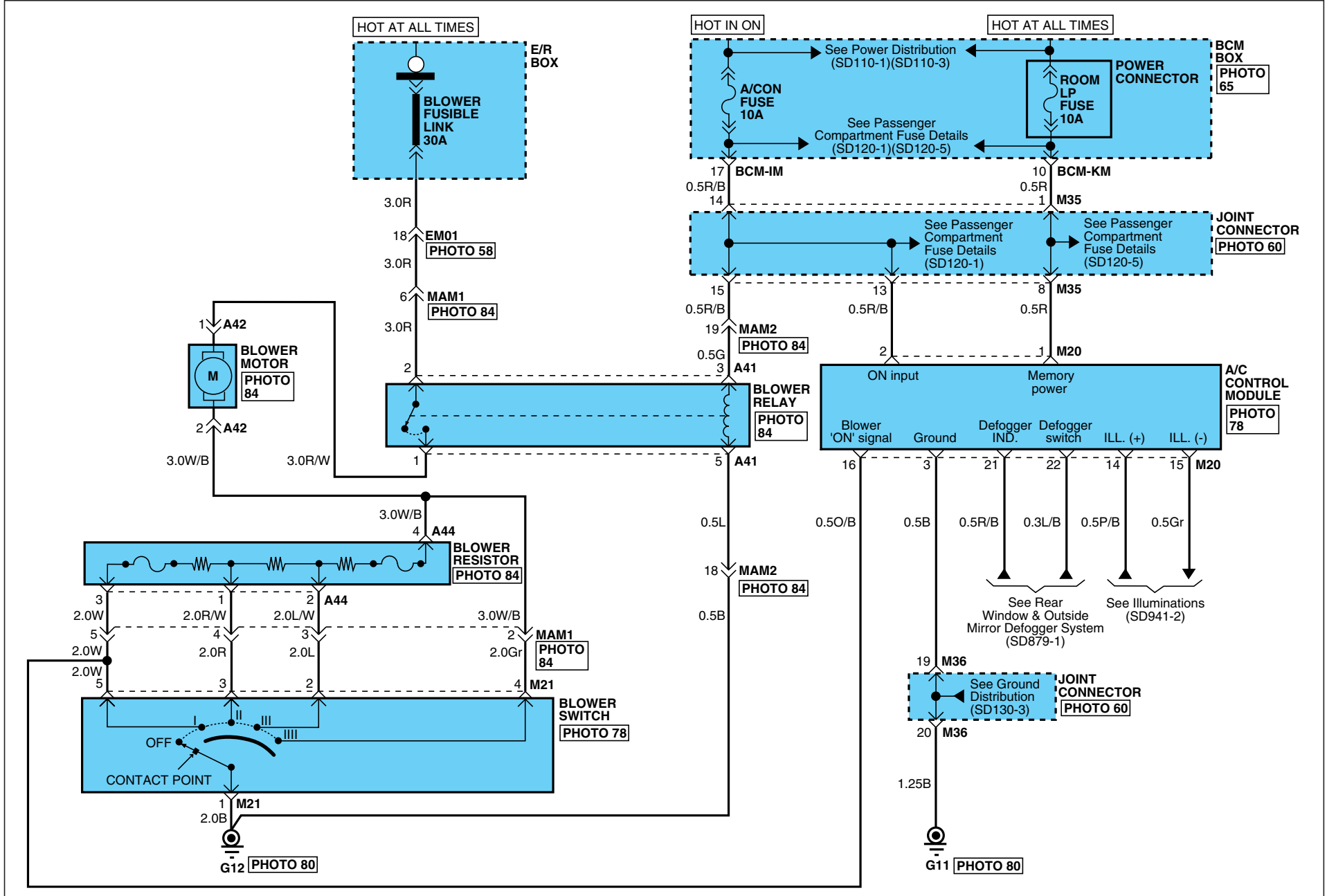

BLOWER & A/C CONTROLS

BLOWER & A/C CONTROLS (MANUAL) (2)



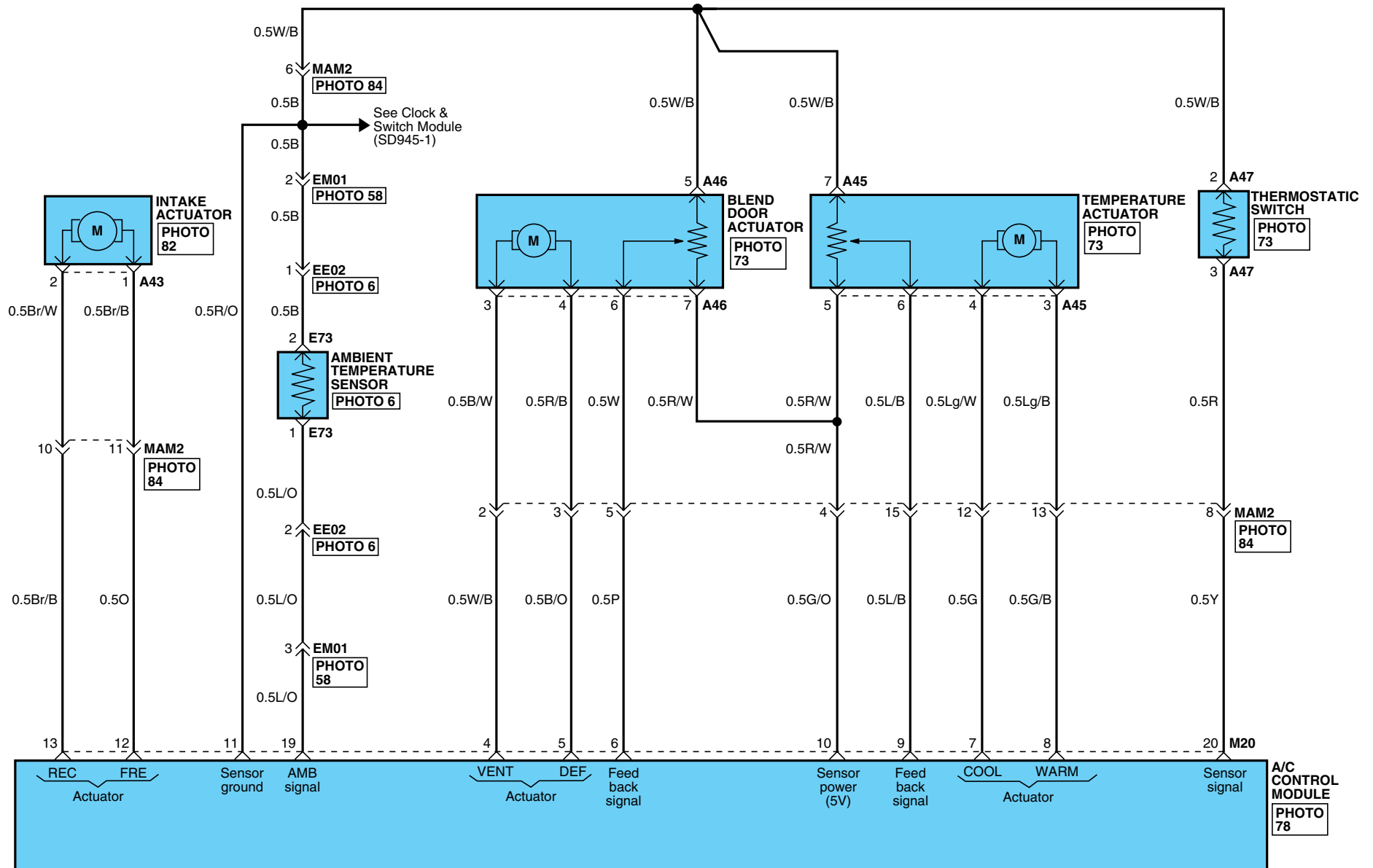

SD971-8

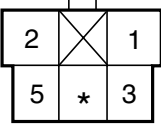
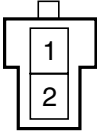
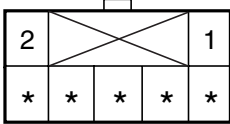
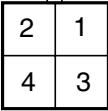
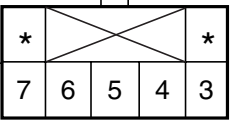
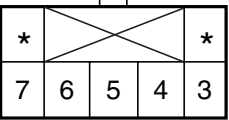
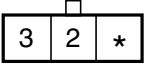

BLOWER & A/C CONTROLS

BLOWER & A/C CONTROLS (MANUAL) (4)

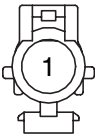
SD971-10

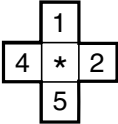
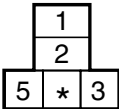
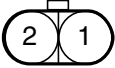
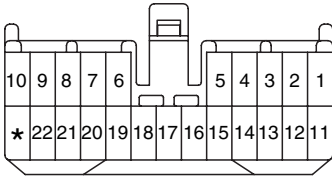
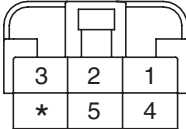
<p style="text-align: center;">A41</p>  <p style="text-align: right; font-size: small;">CR05F026</p>	<p style="text-align: center;">A42</p>  <p style="text-align: right; font-size: small;">CR02M042</p>	<p style="text-align: center;">A43</p>  <p style="text-align: right; font-size: small;">CR07F011</p>	<p style="text-align: center;">A44</p>  <p style="text-align: right; font-size: small;">CR04F001</p>																																																																																																																										
<p style="text-align: center;">A45</p>  <p style="text-align: right; font-size: small;">CR07F011</p>	<p style="text-align: center;">A46</p>  <p style="text-align: right; font-size: small;">CR07F011</p>	<p style="text-align: center;">A47</p>  <p style="text-align: right; font-size: small;">CR03F040</p>	<p style="text-align: center;">C28/C228</p>  <p style="text-align: right; font-size: small;">KUM_NMWP_01F_B</p>																																																																																																																										
<p style="text-align: center;">C33-1</p> <table border="1" style="width: 100%; text-align: center; font-size: x-small;"> <tr><td>6</td><td>7</td><td>8</td><td>9</td><td>10</td><td>11</td><td>*</td><td>*</td><td>14</td><td>*</td><td>*</td><td>17</td><td>18</td><td>*</td><td>*</td><td>21</td><td>22</td><td>23</td><td>24</td><td>5</td><td>4</td></tr> <tr><td>*</td><td>26</td><td>27</td><td>*</td><td>29</td><td>30</td><td>31</td><td>32</td><td>*</td><td>*</td><td>*</td><td>*</td><td>37</td><td>38</td><td>39</td><td>*</td><td>*</td><td>42</td><td>43</td><td colspan="2" rowspan="2">3</td></tr> <tr><td>44</td><td>45</td><td>*</td><td>47</td><td>48</td><td>*</td><td>50</td><td>51</td><td>52</td><td>*</td><td>54</td><td>55</td><td>56</td><td>*</td><td>58</td><td>59</td><td>60</td><td>61</td><td>62</td></tr> <tr><td>*</td><td>64</td><td>65</td><td>66</td><td>67</td><td>68</td><td>69</td><td>70</td><td>*</td><td>72</td><td>73</td><td>*</td><td>75</td><td>76</td><td>77</td><td>78</td><td>*</td><td>80</td><td>81</td><td>2</td><td>1</td></tr> </table> <p style="text-align: right; font-size: x-small;">KET_ECU_81F_B_BOSCH</p>		6	7	8	9	10	11	*	*	14	*	*	17	18	*	*	21	22	23	24	5	4	*	26	27	*	29	30	31	32	*	*	*	*	37	38	39	*	*	42	43	3		44	45	*	47	48	*	50	51	52	*	54	55	56	*	58	59	60	61	62	*	64	65	66	67	68	69	70	*	72	73	*	75	76	77	78	*	80	81	2	1	<p style="text-align: center;">C128</p>  <p style="text-align: right; font-size: small;">KET_SWP_01F_B</p>	<p style="text-align: center;">C133-4</p> <table border="1" style="width: 100%; text-align: center; font-size: x-small;"> <tr><td>40</td><td>39</td><td>38</td><td>37</td><td>36</td><td>*</td><td>*</td><td>*</td><td>*</td><td>*</td></tr> <tr><td>*</td><td>29</td><td>*</td><td>*</td><td>*</td><td>25</td><td>24</td><td>23</td><td>22</td><td>*</td></tr> <tr><td>20</td><td>*</td><td>18</td><td>17</td><td>*</td><td>*</td><td>*</td><td>*</td><td>*</td><td>*</td></tr> <tr><td>10</td><td>*</td><td>8</td><td>7</td><td>*</td><td>*</td><td>*</td><td>*</td><td>*</td><td>*</td></tr> </table> <p style="text-align: right; font-size: small;">AMP_ECU_40F_B_134P</p>	40	39	38	37	36	*	*	*	*	*	*	29	*	*	*	25	24	23	22	*	20	*	18	17	*	*	*	*	*	*	10	*	8	7	*	*	*	*	*	*
6	7	8	9	10	11	*	*	14	*	*	17	18	*	*	21	22	23	24	5	4																																																																																																									
*	26	27	*	29	30	31	32	*	*	*	*	37	38	39	*	*	42	43	3																																																																																																										
44	45	*	47	48	*	50	51	52	*	54	55	56	*	58	59	60	61	62																																																																																																											
*	64	65	66	67	68	69	70	*	72	73	*	75	76	77	78	*	80	81	2	1																																																																																																									
40	39	38	37	36	*	*	*	*	*																																																																																																																				
*	29	*	*	*	25	24	23	22	*																																																																																																																				
20	*	18	17	*	*	*	*	*	*																																																																																																																				
10	*	8	7	*	*	*	*	*	*																																																																																																																				
<p style="text-align: center;">C233</p> <table border="1" style="width: 100%; text-align: center; font-size: x-small;"> <tr><td>6</td><td>7</td><td>8</td><td>*</td><td>*</td><td>11</td><td>12</td><td>13</td><td>14</td><td>15</td><td>16</td><td>17</td><td>18</td><td>19</td><td>20</td><td>*</td><td>*</td><td>*</td><td>24</td><td>5</td><td>*</td></tr> <tr><td>*</td><td>26</td><td>27</td><td>28</td><td>29</td><td>*</td><td>31</td><td>32</td><td>33</td><td>34</td><td>35</td><td>36</td><td>37</td><td>*</td><td>39</td><td>*</td><td>*</td><td>42</td><td>*</td><td colspan="2" rowspan="2">3</td></tr> <tr><td>44</td><td>45</td><td>46</td><td>47</td><td>48</td><td>49</td><td>50</td><td>51</td><td>52</td><td>53</td><td>*</td><td>55</td><td>*</td><td>57</td><td>*</td><td>59</td><td>60</td><td>61</td><td>*</td></tr> <tr><td>63</td><td>*</td><td>*</td><td>*</td><td>*</td><td>68</td><td>69</td><td>70</td><td>71</td><td>*</td><td>73</td><td>74</td><td>75</td><td>*</td><td>*</td><td>*</td><td>79</td><td>80</td><td>*</td><td>2</td><td>*</td></tr> </table> <p style="text-align: right; font-size: x-small;">KET_ECU_81F_B_BOSCH</p>		6	7	8	*	*	11	12	13	14	15	16	17	18	19	20	*	*	*	24	5	*	*	26	27	28	29	*	31	32	33	34	35	36	37	*	39	*	*	42	*	3		44	45	46	47	48	49	50	51	52	53	*	55	*	57	*	59	60	61	*	63	*	*	*	*	68	69	70	71	*	73	74	75	*	*	*	79	80	*	2	*	<p style="text-align: center;">E25/E26</p>  <p style="text-align: right; font-size: small;">AMP_EJWP_04F_B</p>	<p style="text-align: center;">E42</p>  <p style="text-align: right; font-size: small;">CR05F019</p>																																								
6	7	8	*	*	11	12	13	14	15	16	17	18	19	20	*	*	*	24	5	*																																																																																																									
*	26	27	28	29	*	31	32	33	34	35	36	37	*	39	*	*	42	*	3																																																																																																										
44	45	46	47	48	49	50	51	52	53	*	55	*	57	*	59	60	61	*																																																																																																											
63	*	*	*	*	68	69	70	71	*	73	74	75	*	*	*	79	80	*	2	*																																																																																																									
<p style="text-align: center;">E50</p>  <p style="text-align: right; font-size: small;">CR05F011</p>	<p style="text-align: center;">E73</p>  <p style="text-align: right; font-size: small;">CR02F001</p>	<p style="text-align: center;">M20</p>  <p style="text-align: right; font-size: small;">KET_050_23F_W</p>	<p style="text-align: center;">M21</p>  <p style="text-align: right; font-size: small;">KET_250DL_06F_W</p>																																																																																																																										

FRONT WIPER & WASHER (1)

SD981-1

LHD

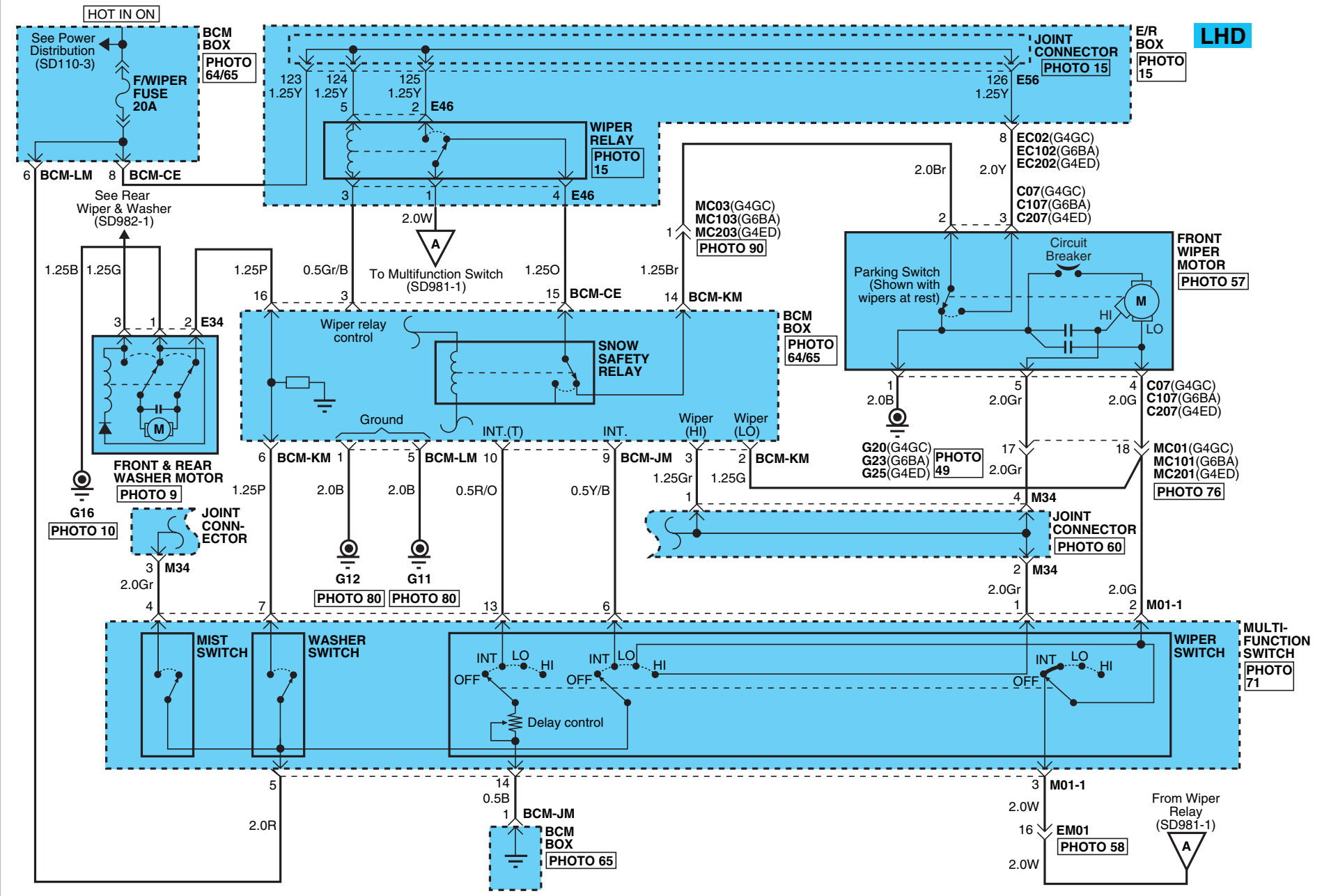

FRONT WIPER & WASHER

FRONT WIPER & WASHER (3)

SD981-3

C07/C107/C207

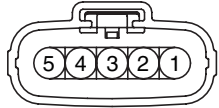

KUM_NDWP_05F_B

C08/C108/C208

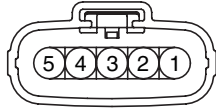

KUM_NDWP_05F_B

E34



KET_090IWP_03F_W

E46

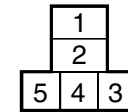

CR05F011

M01-1

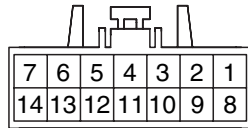

KET_090II_14F_W_SW

M02-1

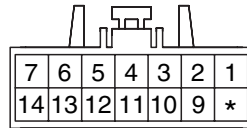

KET_090II_14F_W_SW

BLANK

BLANK

FRONT WIPER & WASHER

FRONT WIPER & WASHER (4)

SD981-4

MEMO

REAR WIPER & WASHER (1)

SD982-1

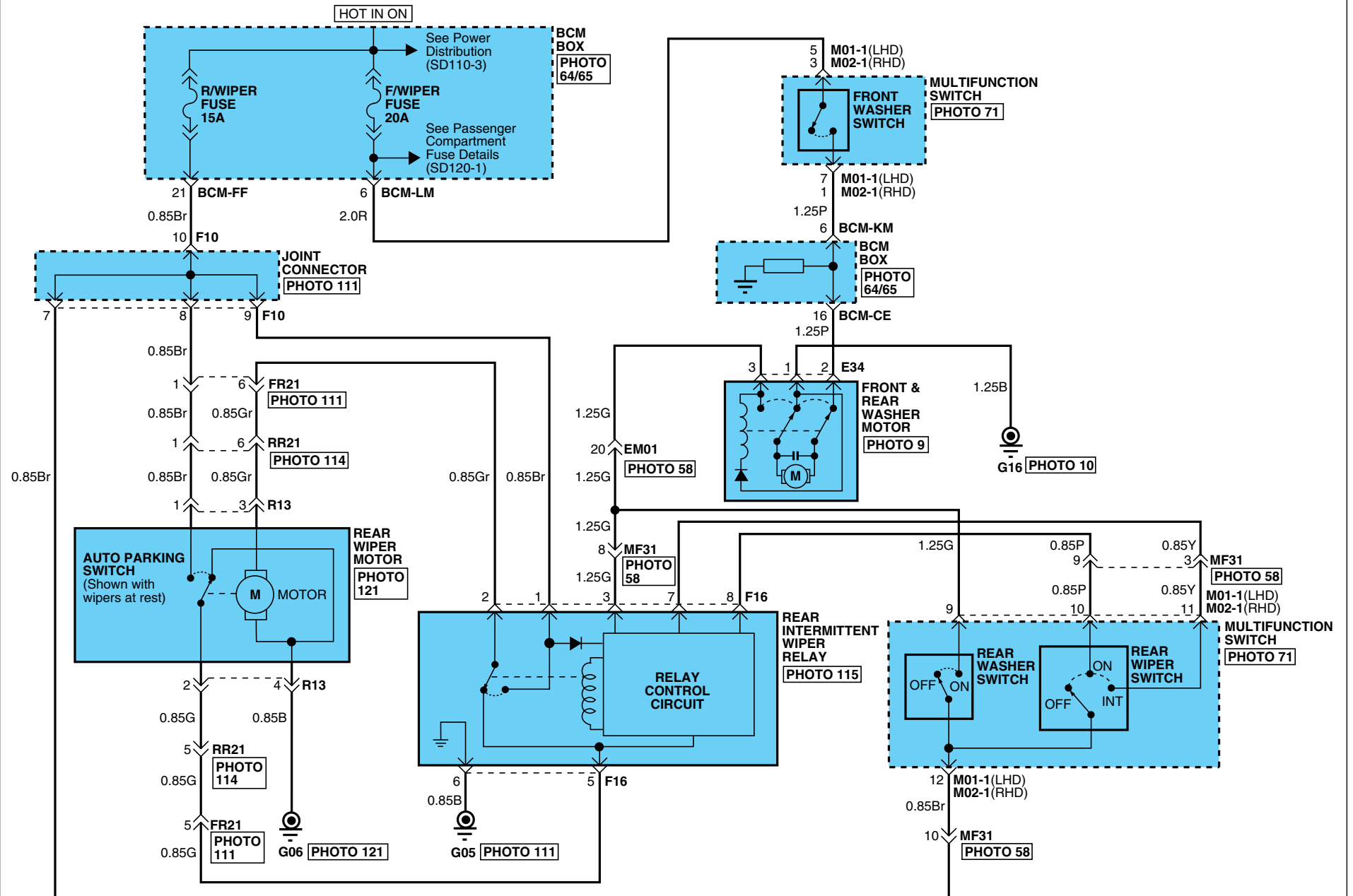

REAR WIPER & WASHER

REAR WIPER & WASHER (2)

SD982-2

E34

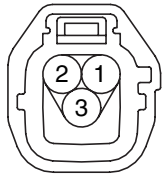

KET_090IWP_03F_W

F16

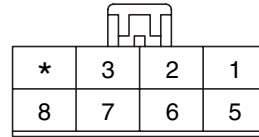

KUM_DSD_08F_W

M01-1

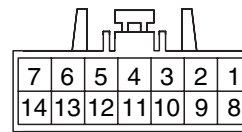

KET_090II_14F_W_SW

M02-1

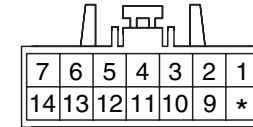

KET_090II_14F_W_SW

R13

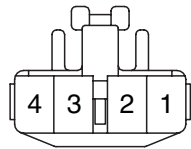

KET_090II_04F_W

BLANK

BLANK

BLANK

COMPONENT LOCATIONS (1)

CL-1

PHOTO.1

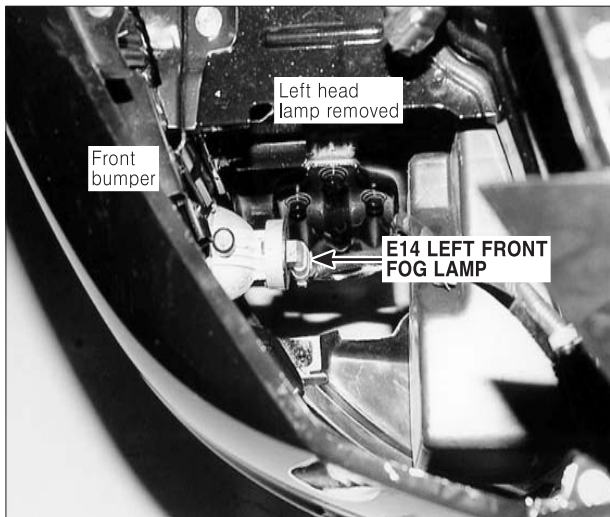

PHOTO.2

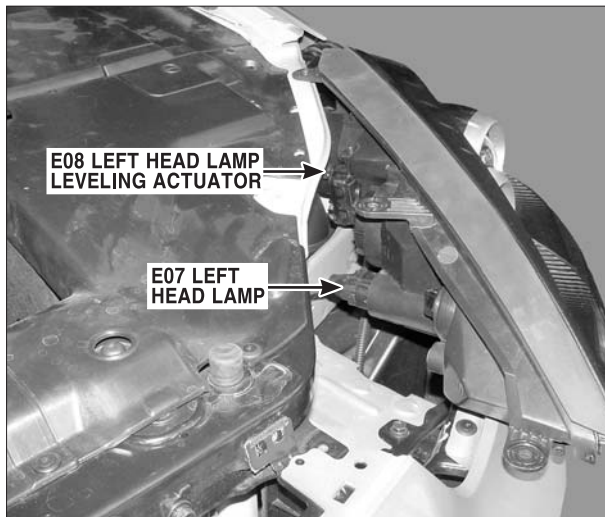

PHOTO.3



PHOTO.4

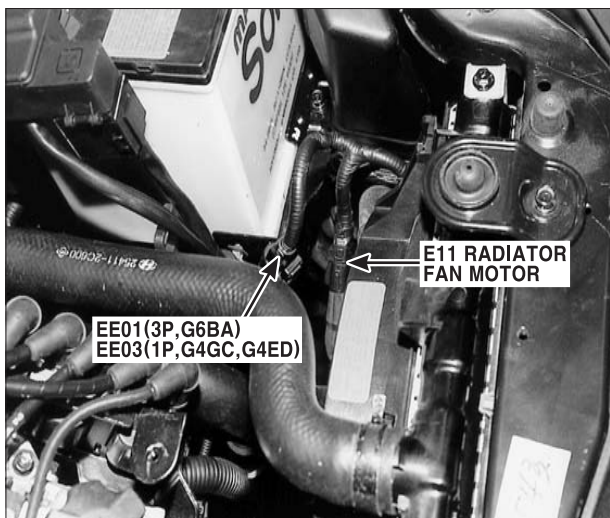

PHOTO.5

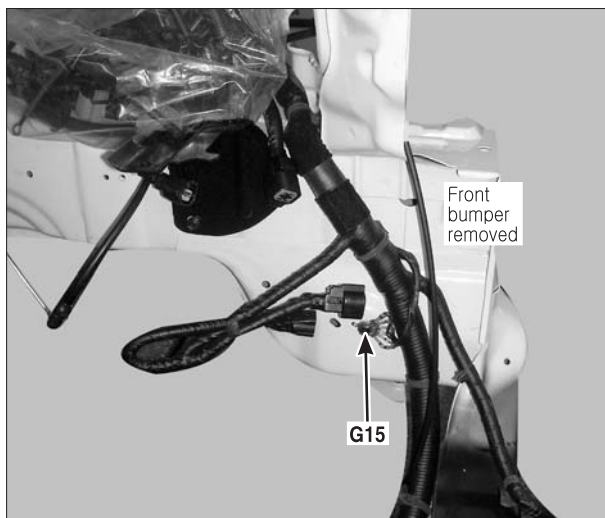
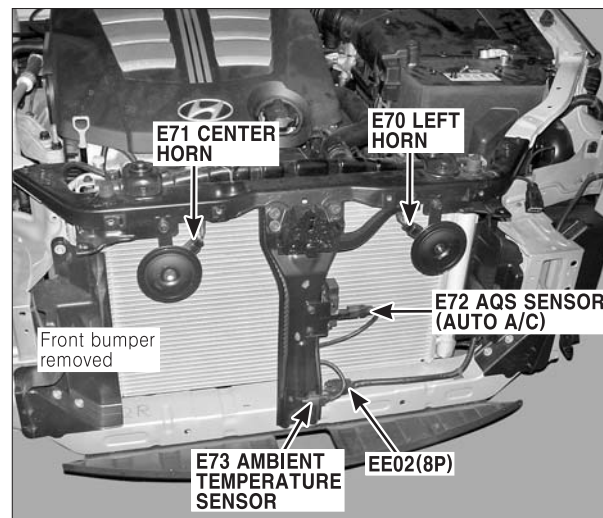

PHOTO.6



COMPONENT LOCATIONS

COMPONENT LOCATIONS (2)

CL-2

PHOTO.7

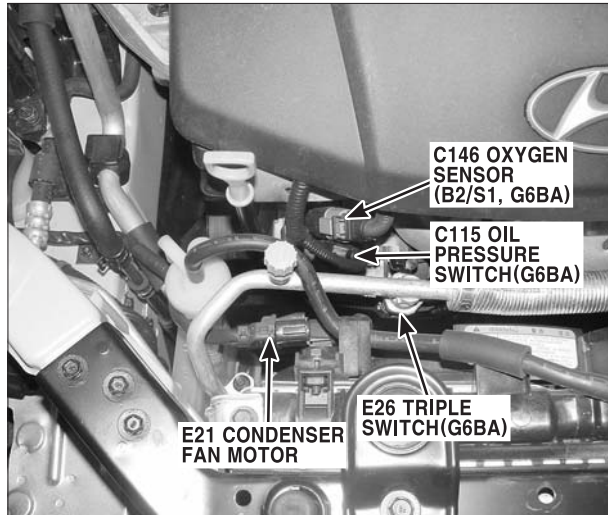

PHOTO.8

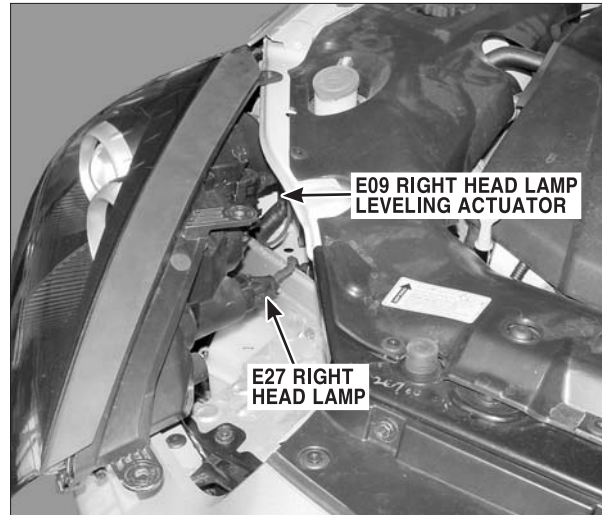

PHOTO.9



PHOTO.10

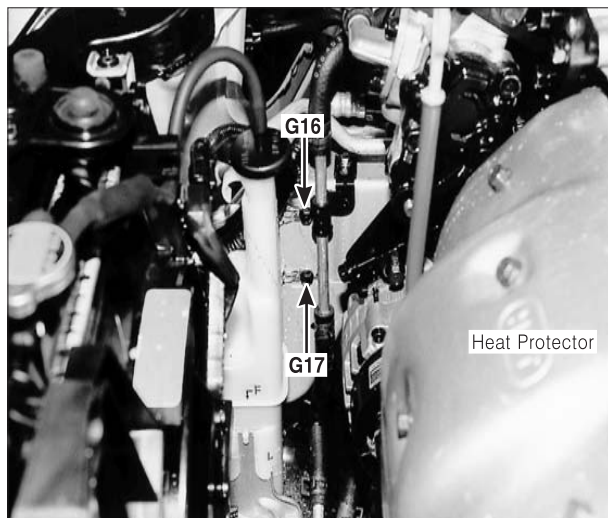

PHOTO.11

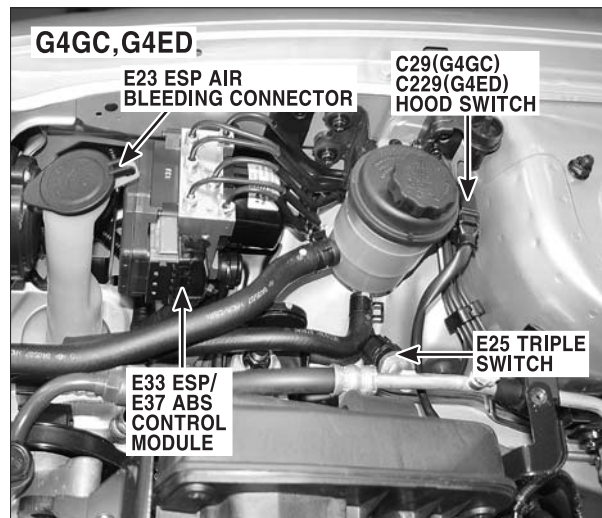
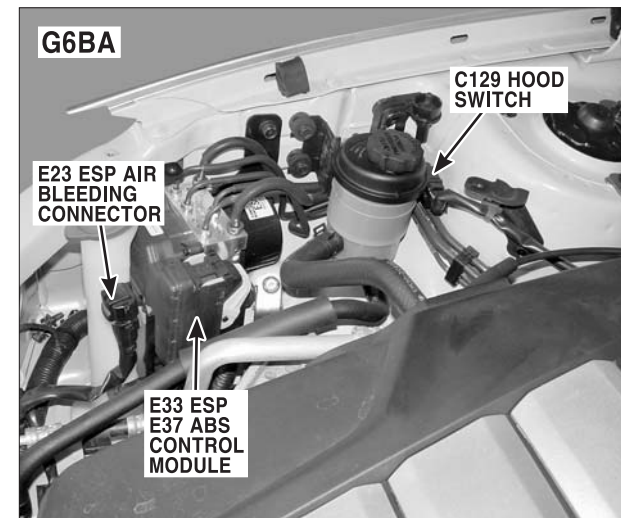

PHOTO.12



COMPONENT LOCATIONS

COMPONENT LOCATIONS (3)

CL-3

PHOTO.13

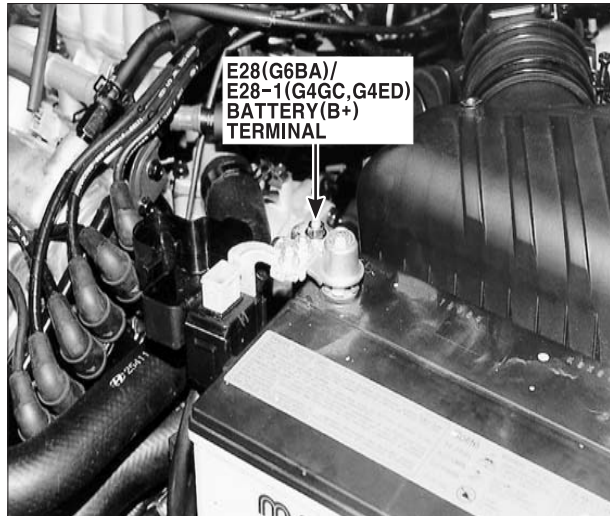

PHOTO.14

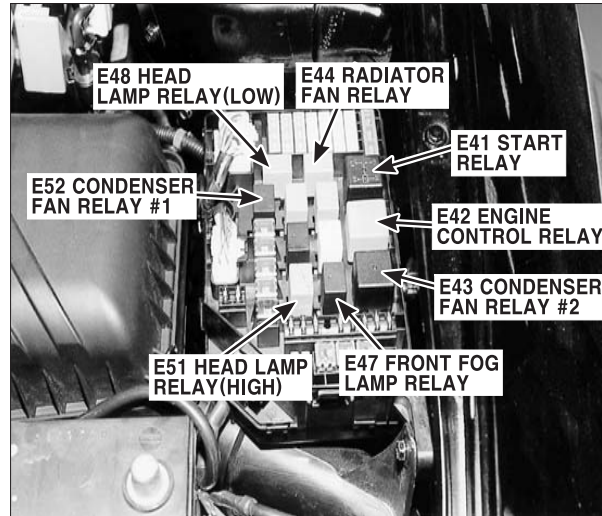

PHOTO.15

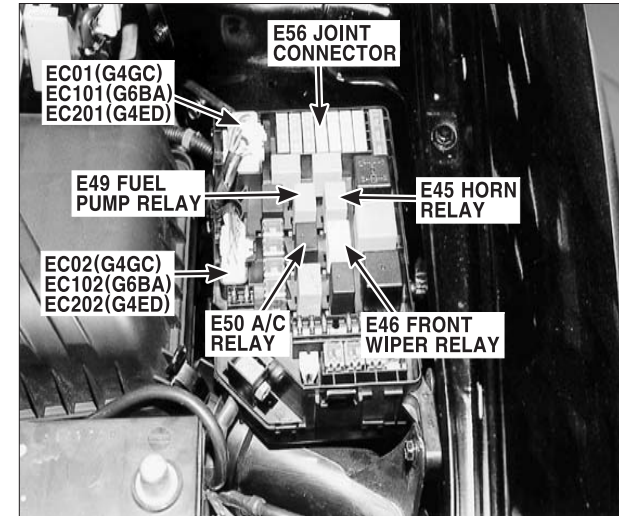

PHOTO.16

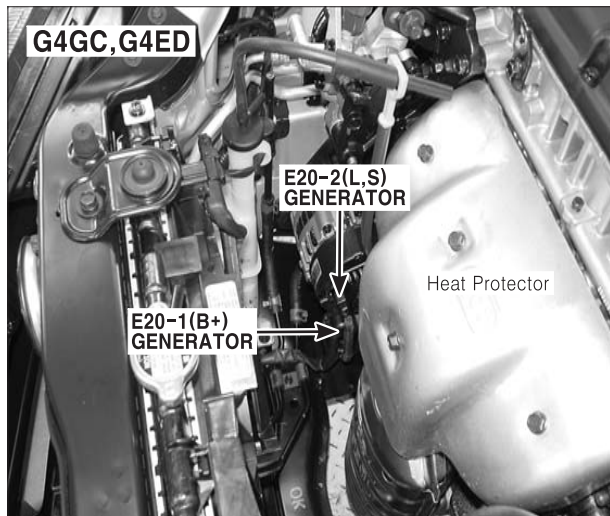

PHOTO.17

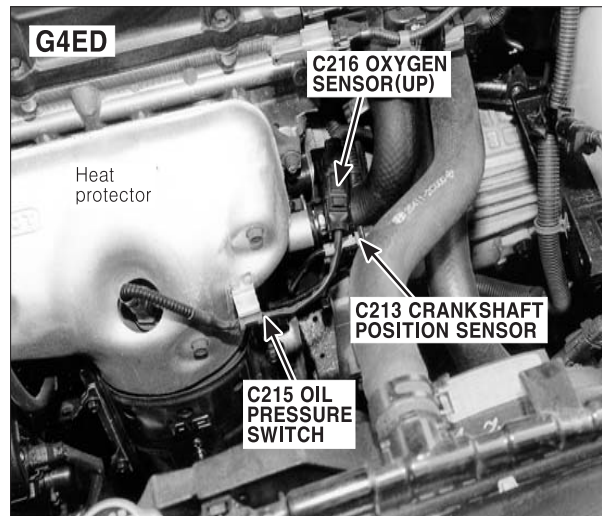
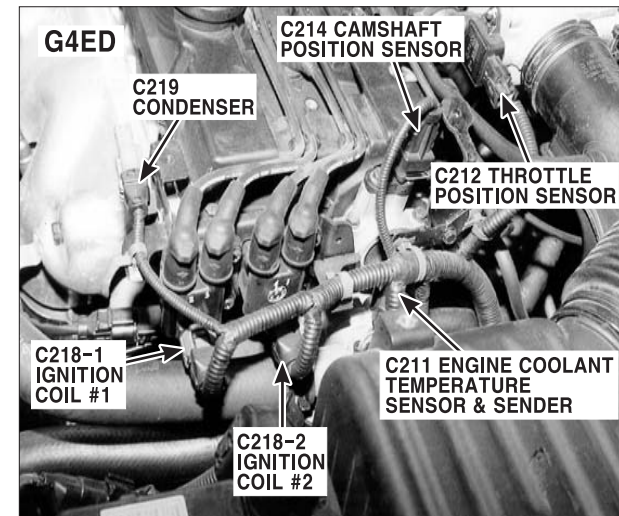

PHOTO.18



COMPONENT LOCATIONS

COMPONENT LOCATIONS (4)

CL-4

PHOTO.19

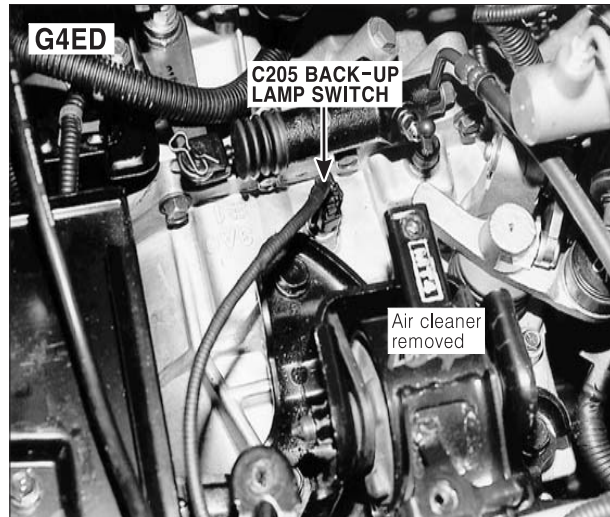

PHOTO.20

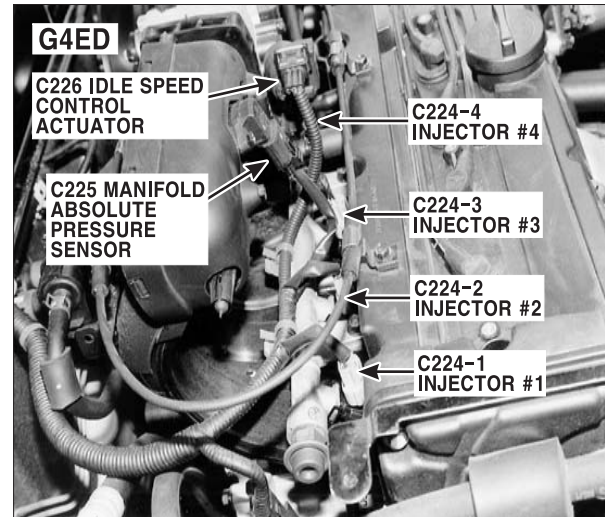

PHOTO.21

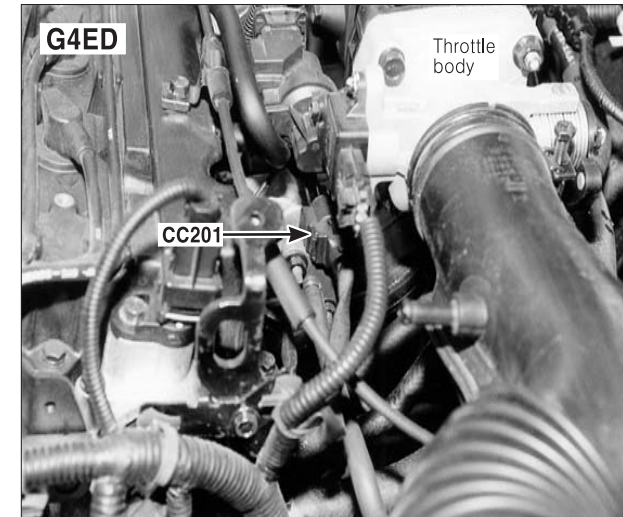

PHOTO.22

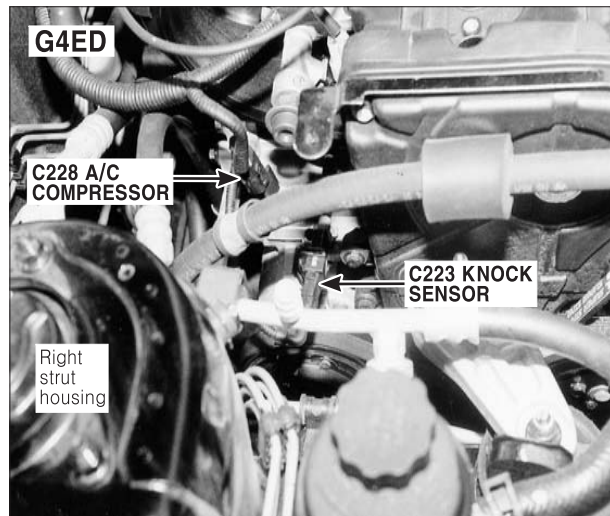

PHOTO.23

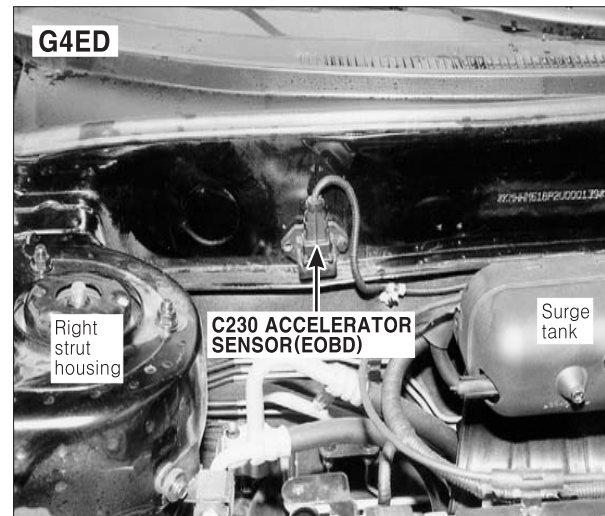
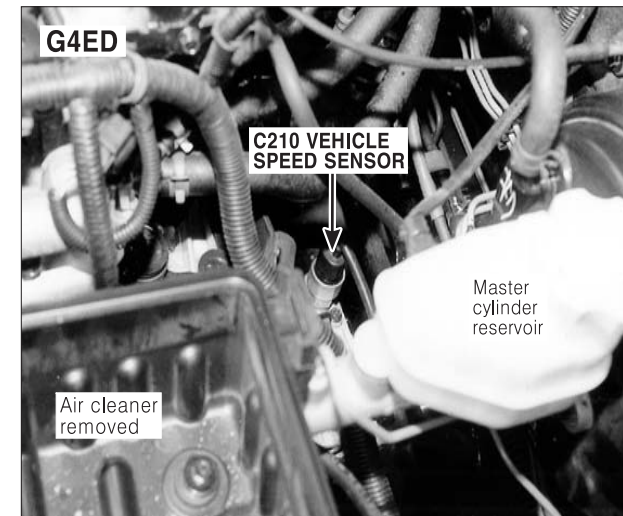

PHOTO.24



COMPONENT LOCATIONS

COMPONENT LOCATIONS (5)

CL-5

PHOTO.25

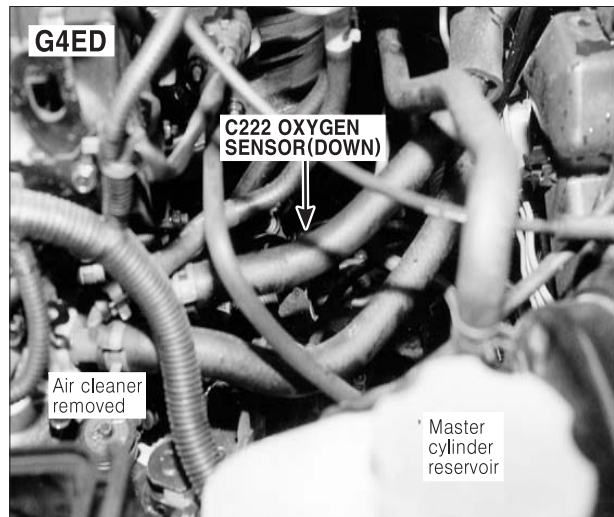

PHOTO.26

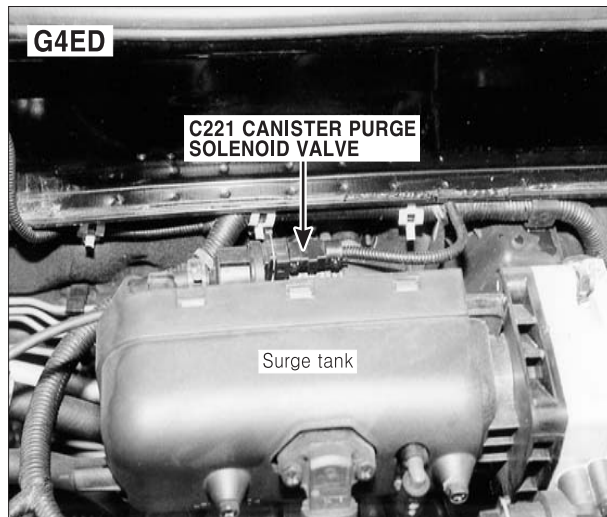

PHOTO.27

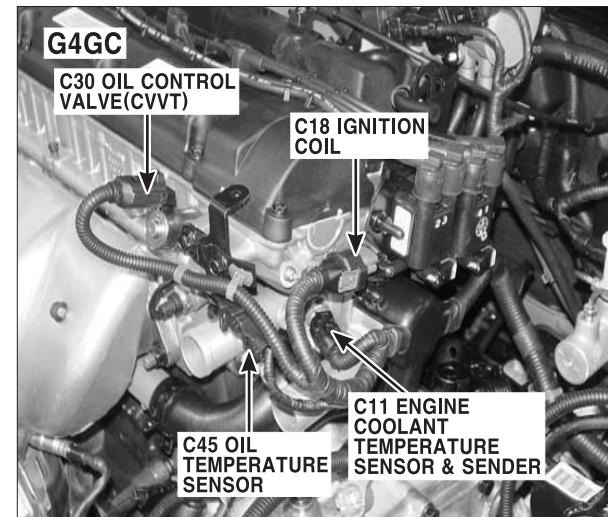

PHOTO.28

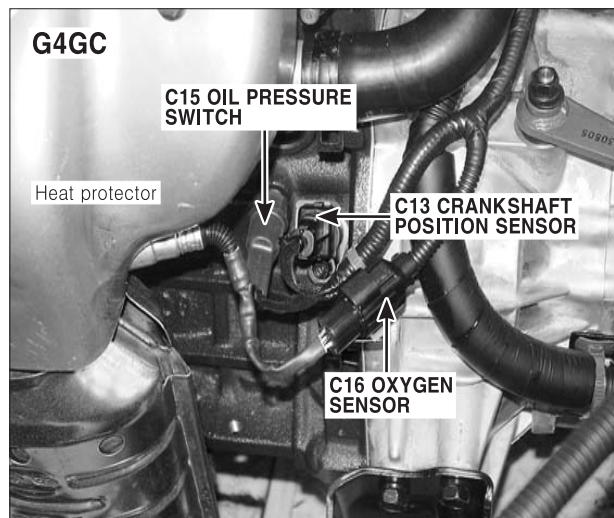

PHOTO.29

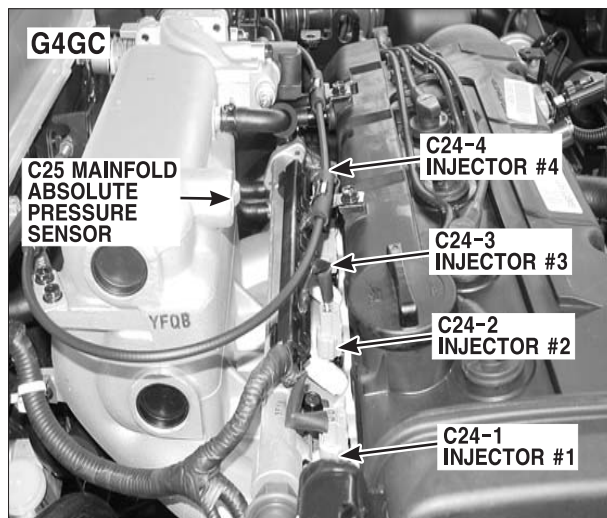
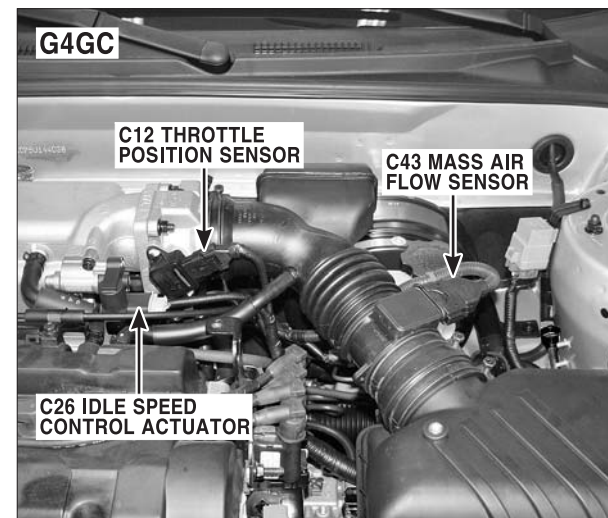

PHOTO.30



COMPONENT LOCATIONS

COMPONENT LOCATIONS (6)

CL-6

PHOTO.31



PHOTO.32

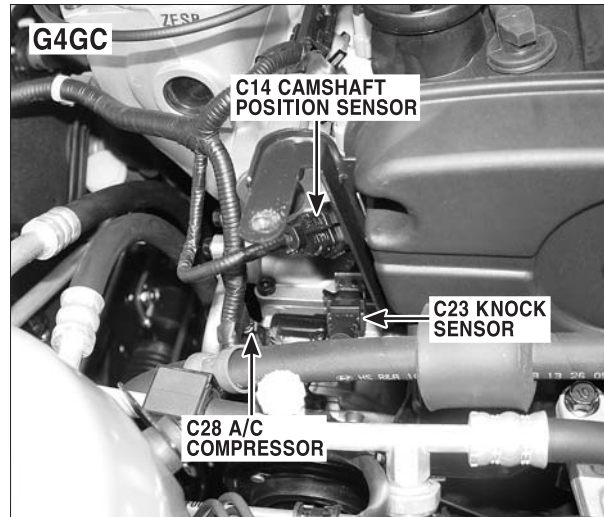

PHOTO.33

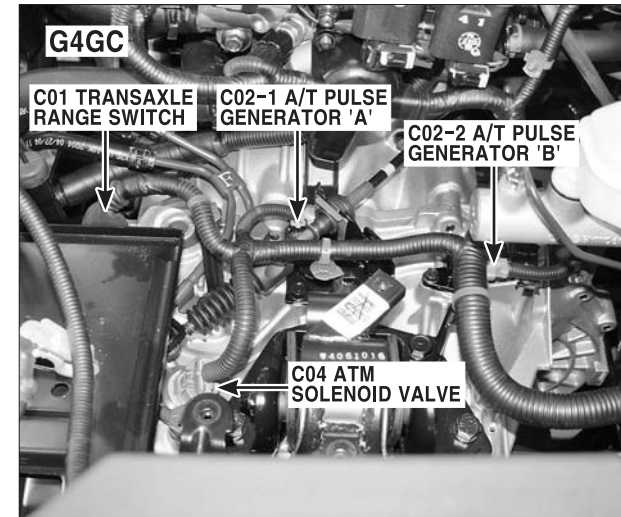

PHOTO.34

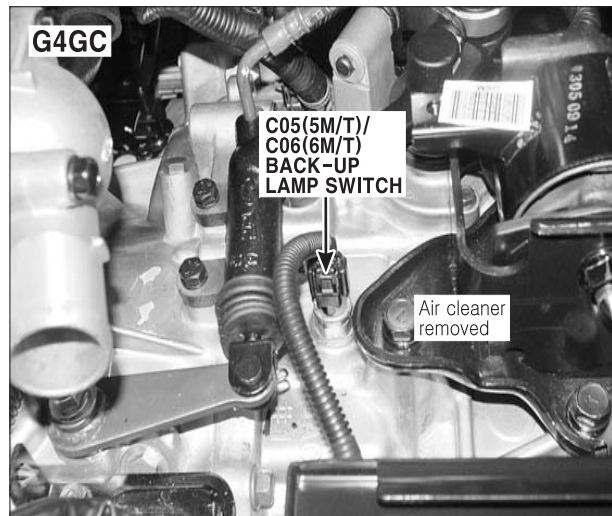

PHOTO.35

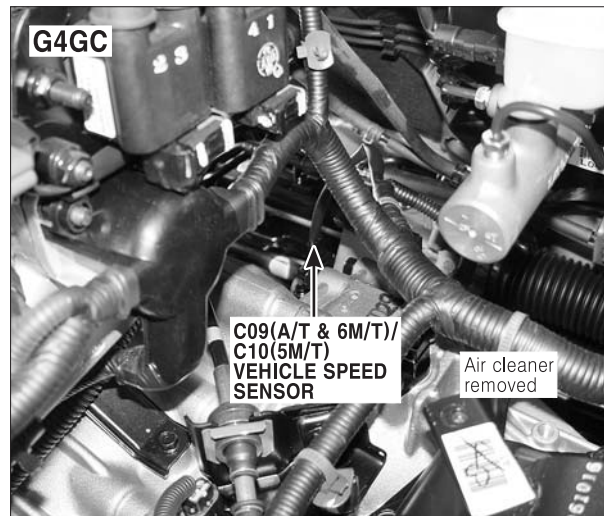
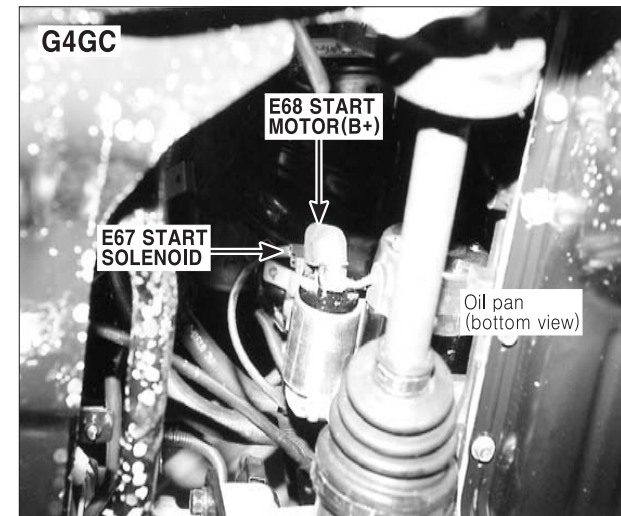

PHOTO.36



COMPONENT LOCATIONS

COMPONENT LOCATIONS (7)

CL-7

PHOTO.37

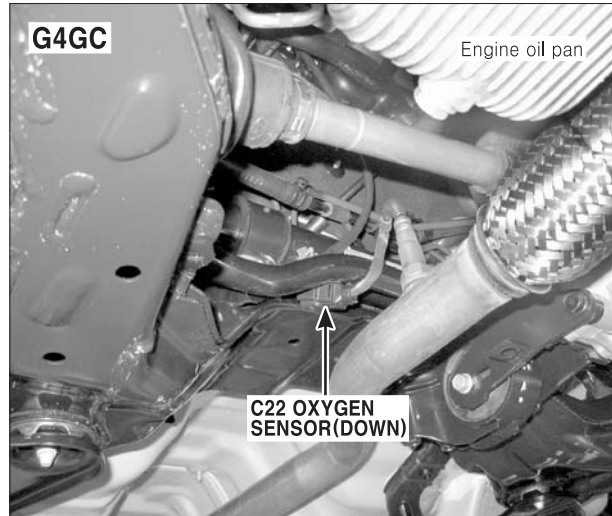

PHOTO.38

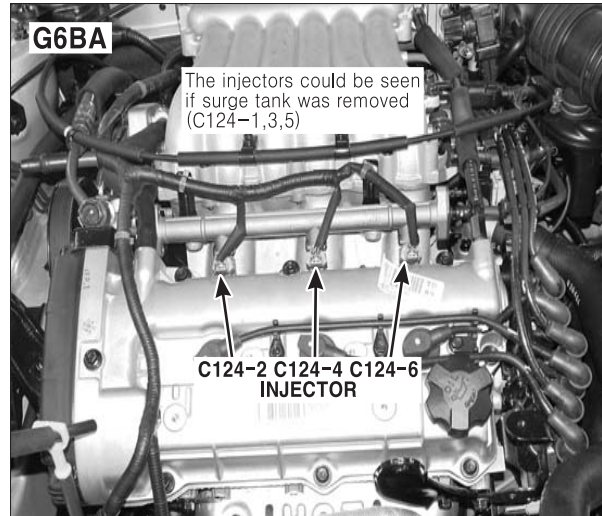

PHOTO.39

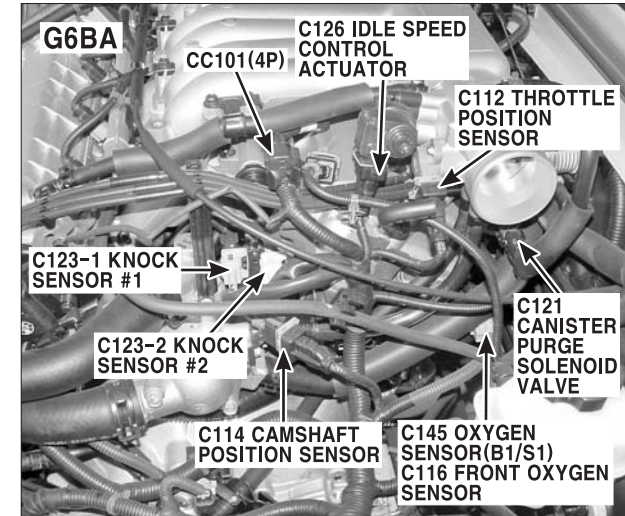

PHOTO.40

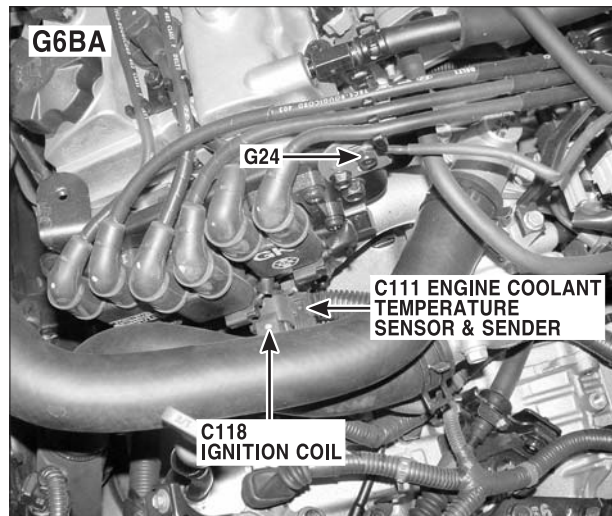

PHOTO.41

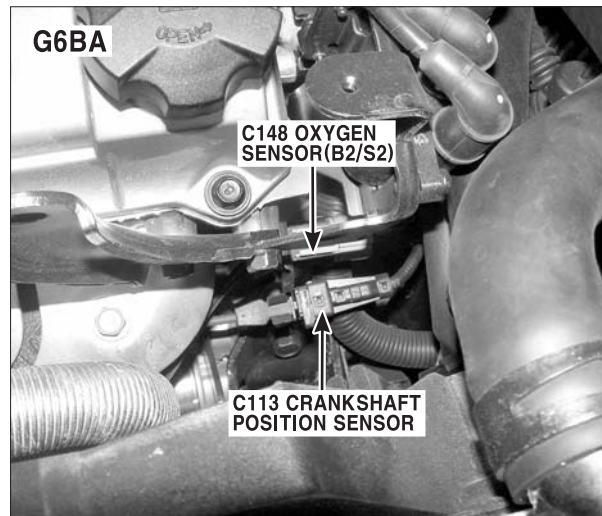
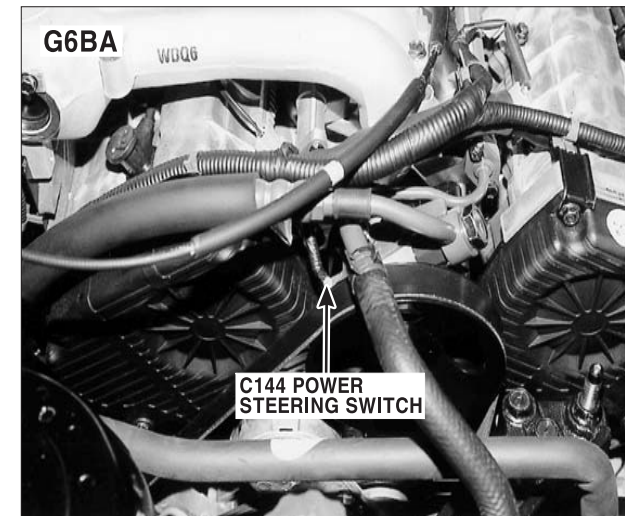

PHOTO.42



COMPONENT LOCATIONS

COMPONENT LOCATIONS (8)

CL-8

PHOTO.43

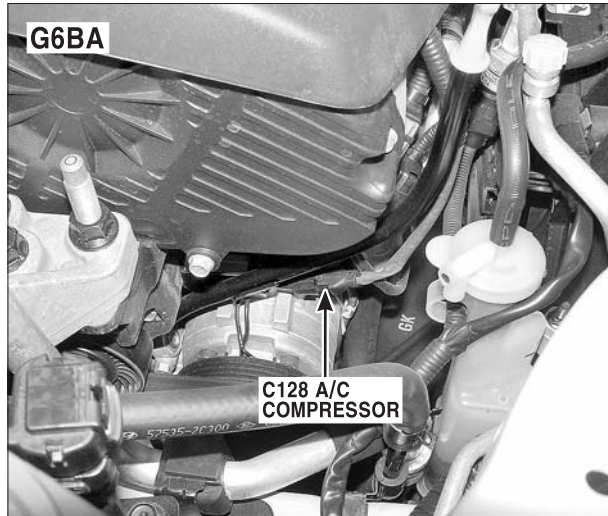

PHOTO.44

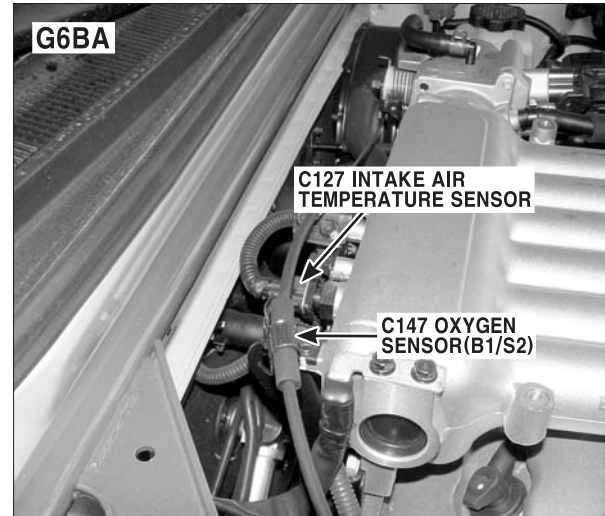

PHOTO.45

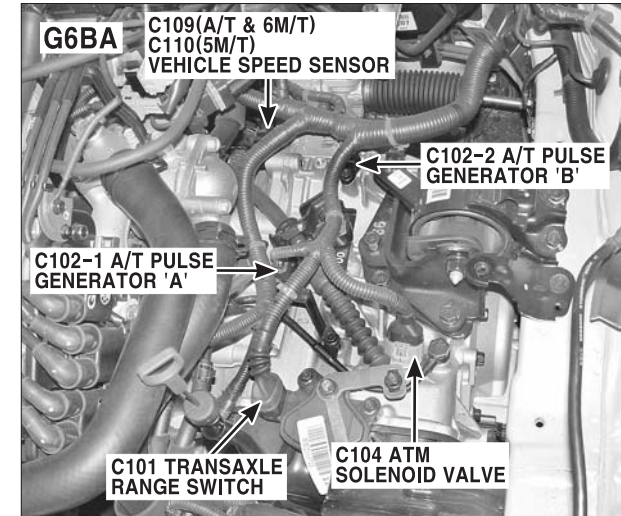

PHOTO.46



PHOTO.47

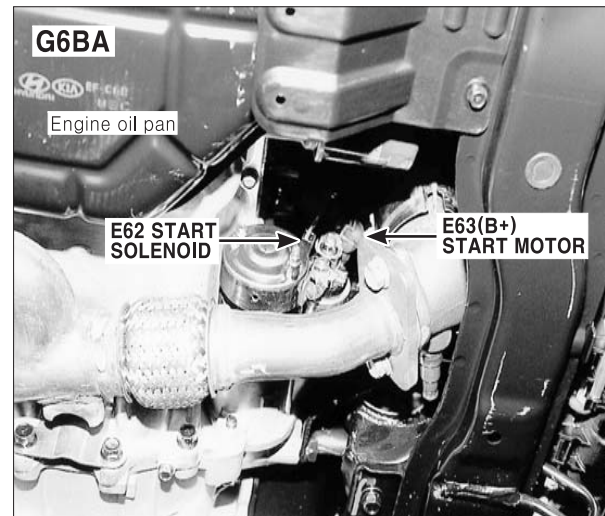
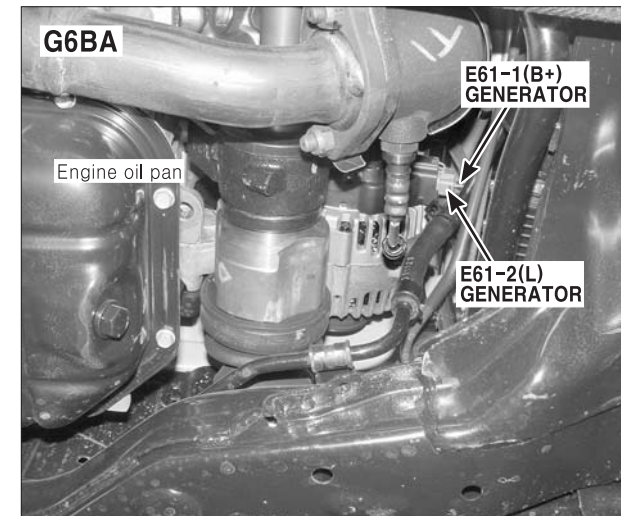

PHOTO.48



COMPONENT LOCATIONS

COMPONENT LOCATIONS (9)

CL-9

PHOTO.49

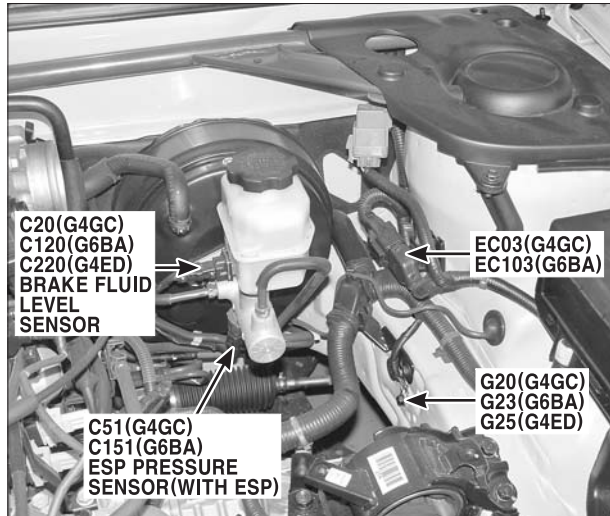

PHOTO.50

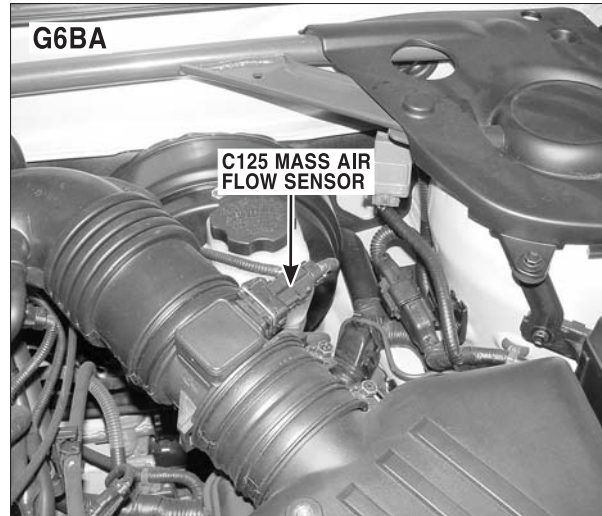

PHOTO.51

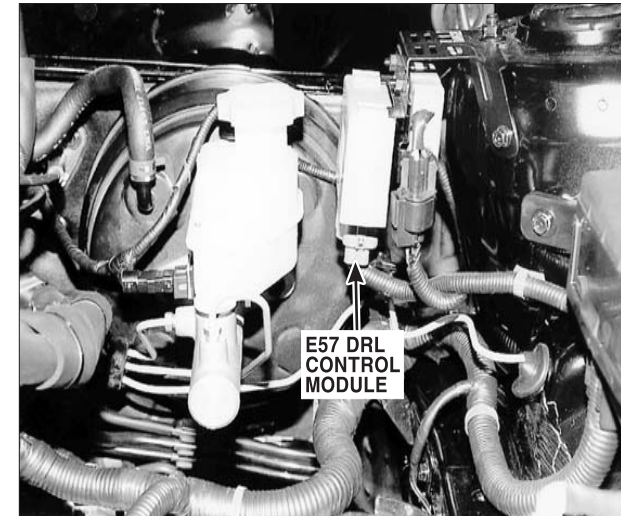

PHOTO.52



PHOTO.53



PHOTO.54

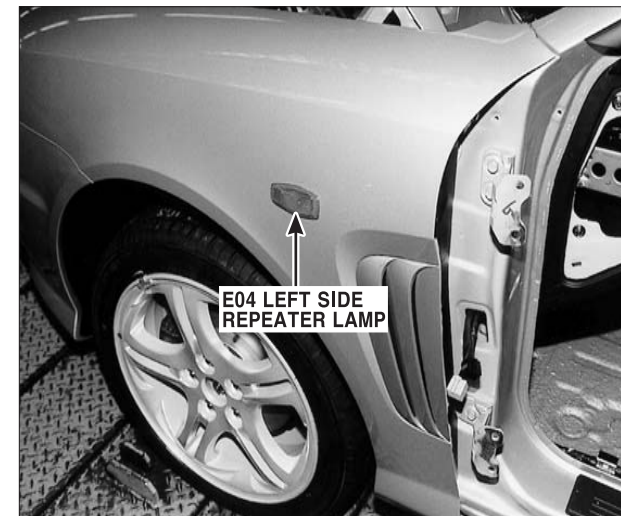

COMPONENT LOCATIONS

COMPONENT LOCATIONS (10)

CL-10

PHOTO.55



PHOTO.56

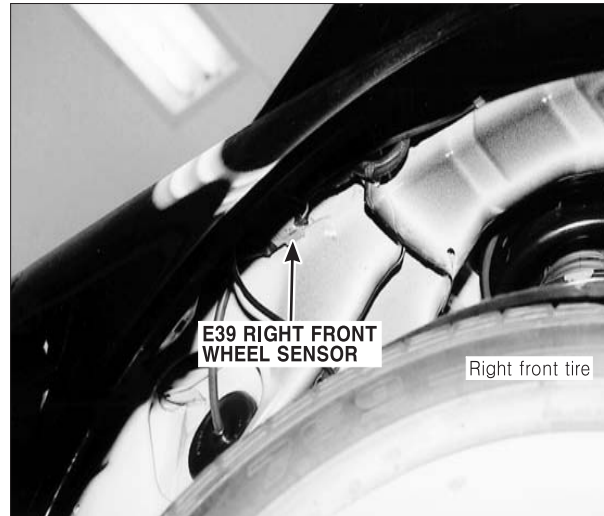

PHOTO.57

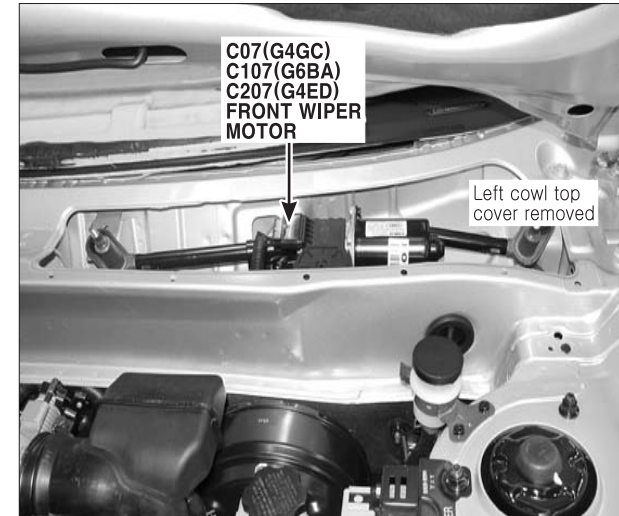

PHOTO.58

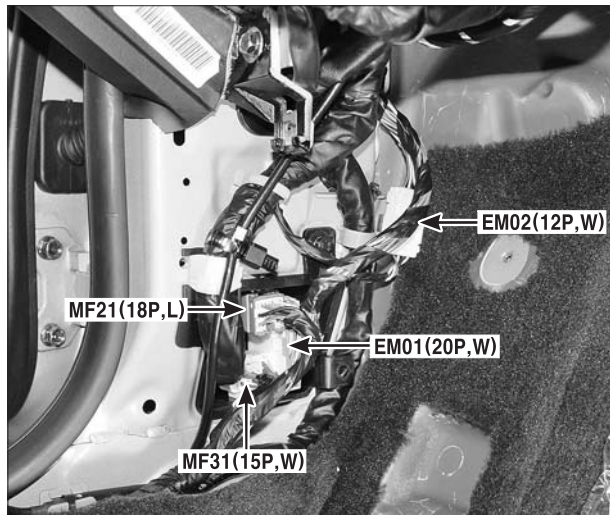

PHOTO.59

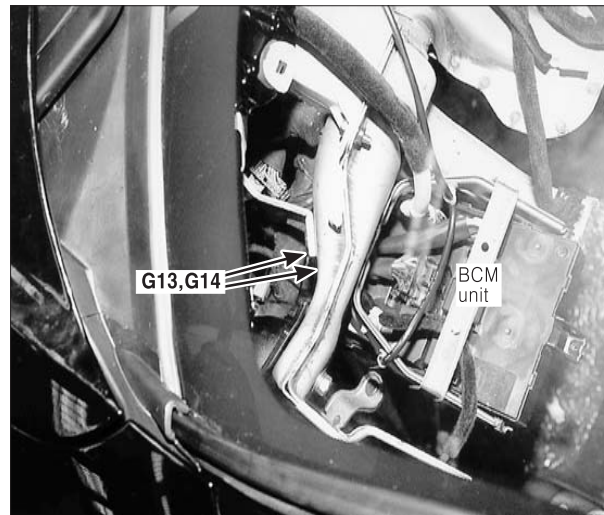
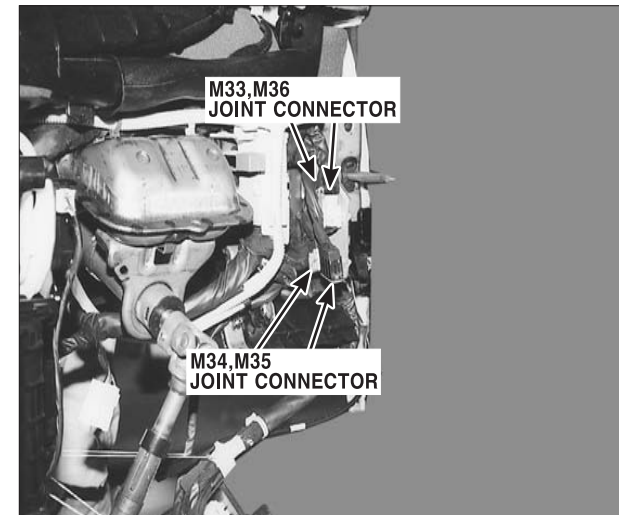

PHOTO.60



COMPONENT LOCATIONS

COMPONENT LOCATIONS (11)

CL-11

PHOTO.61

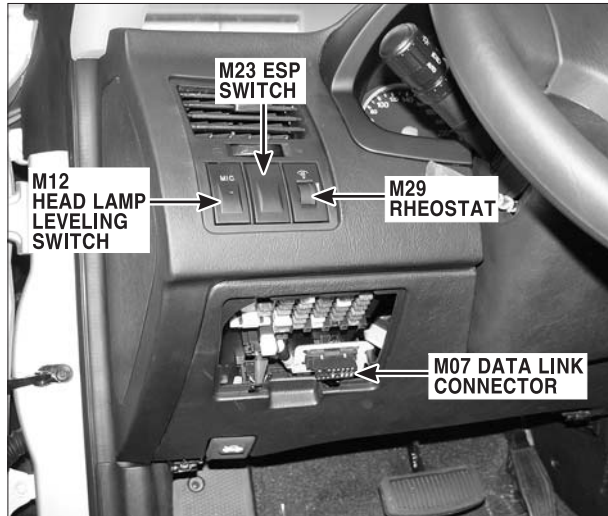

PHOTO.62

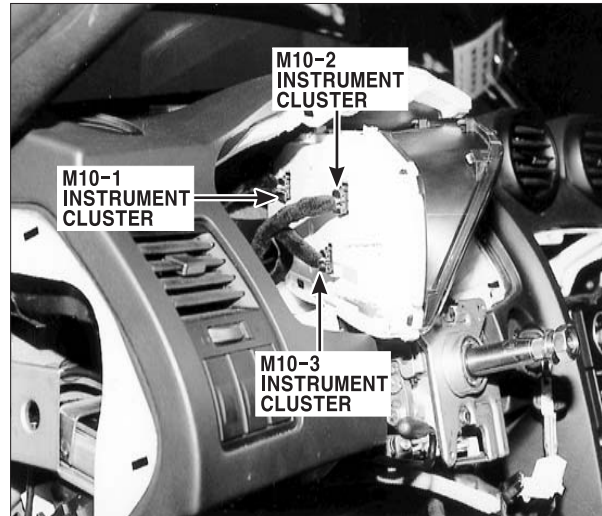

PHOTO.63

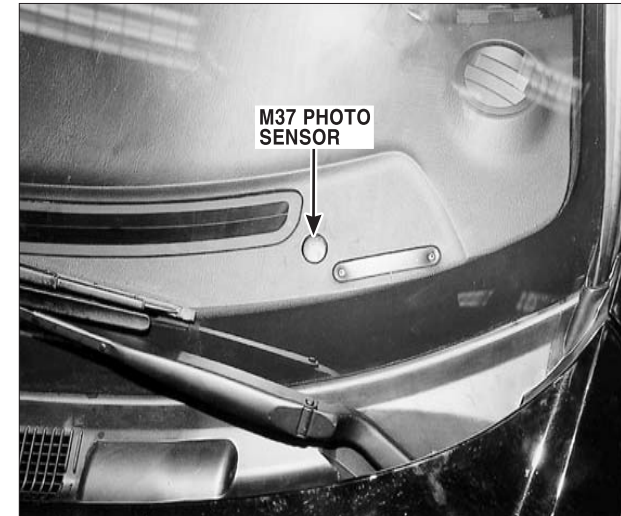

PHOTO.64

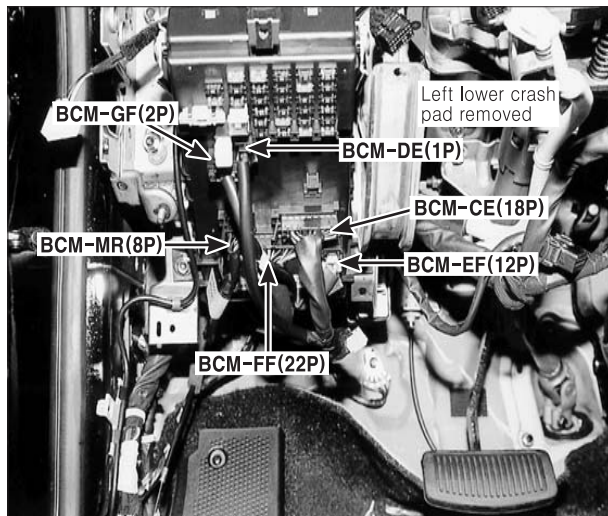

PHOTO.65

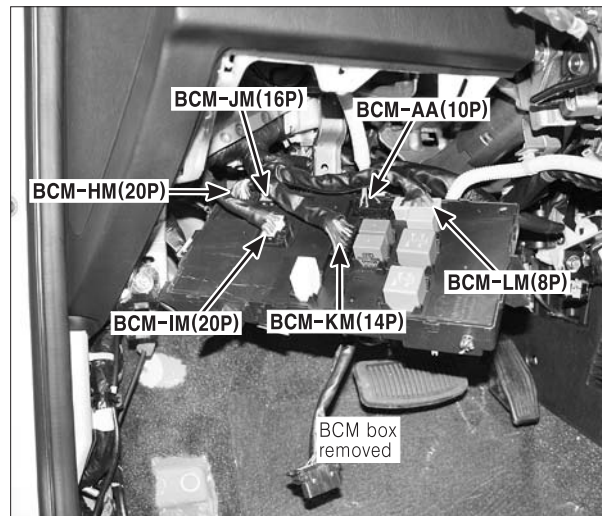
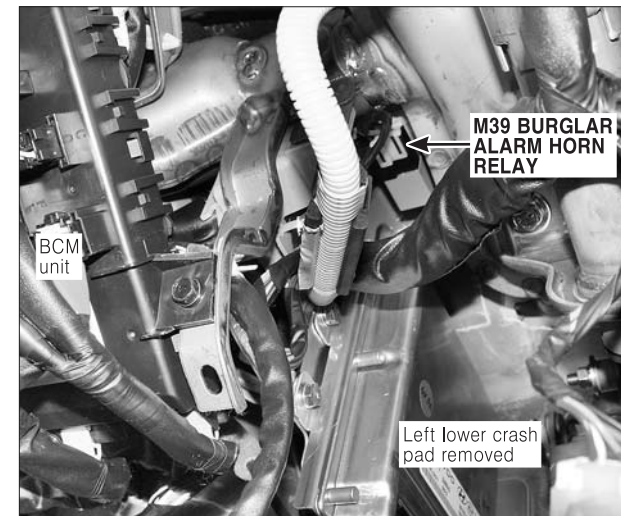

PHOTO.66



COMPONENT LOCATIONS

COMPONENT LOCATIONS (12)

CL-12

PHOTO.67

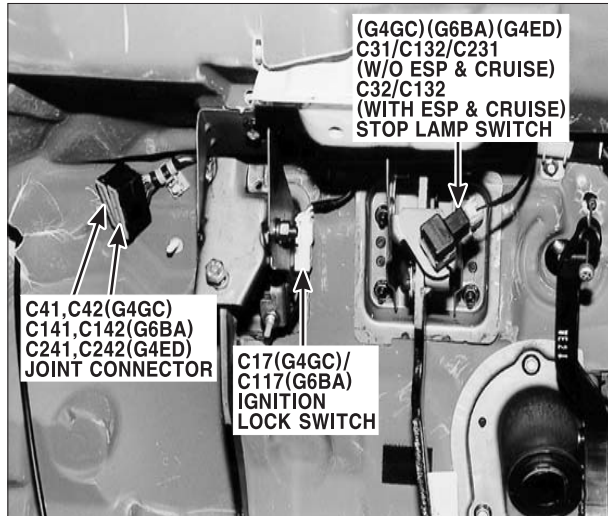

PHOTO.68

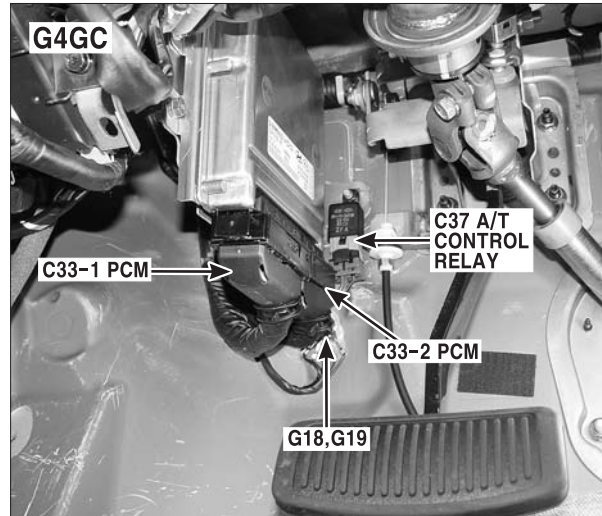

PHOTO.69

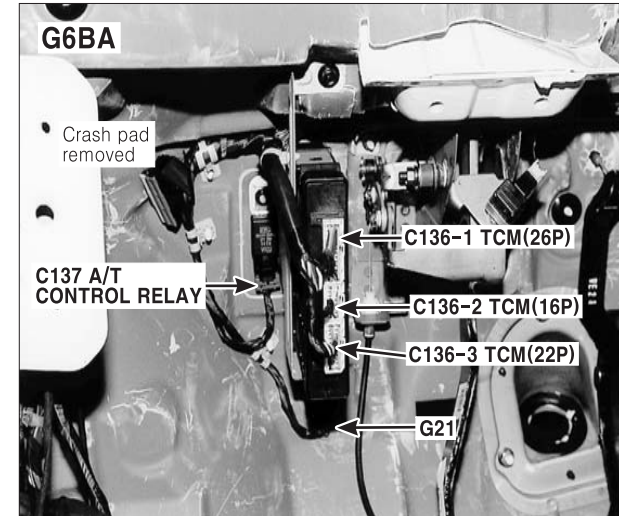

PHOTO.70

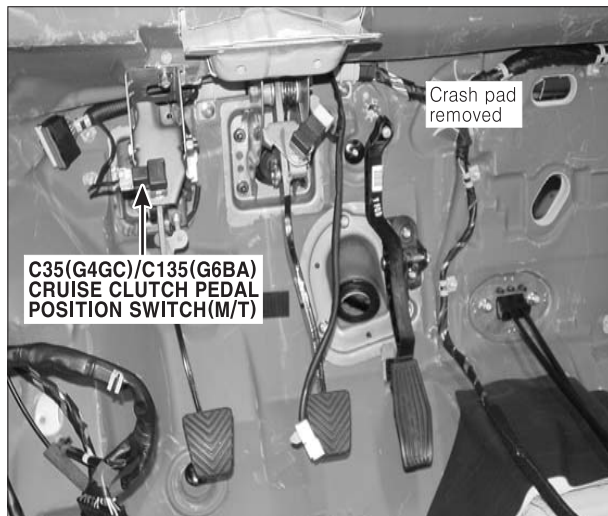

PHOTO.71

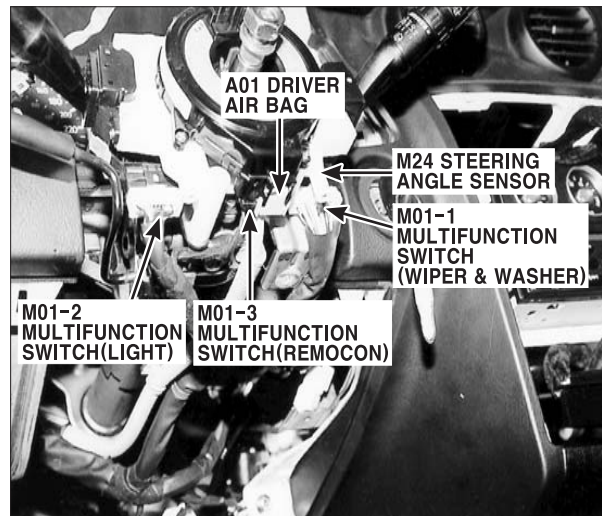
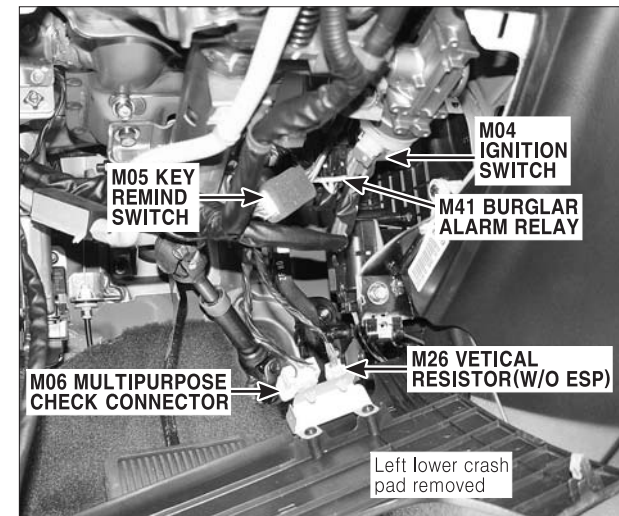

PHOTO.72



COMPONENT LOCATIONS

COMPONENT LOCATIONS (13)

CL-13

PHOTO.73

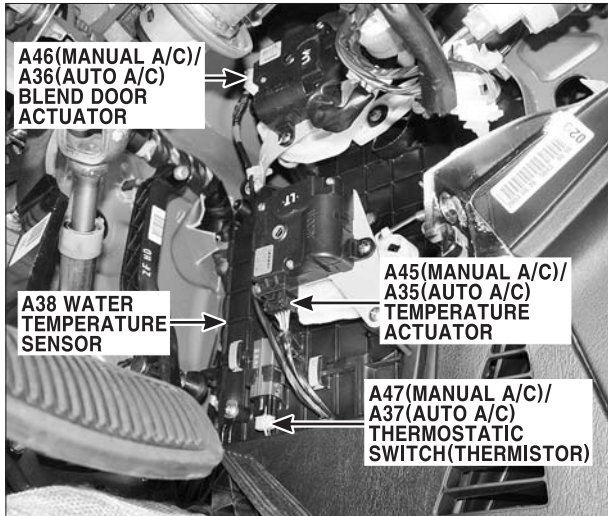

PHOTO.74



PHOTO.75

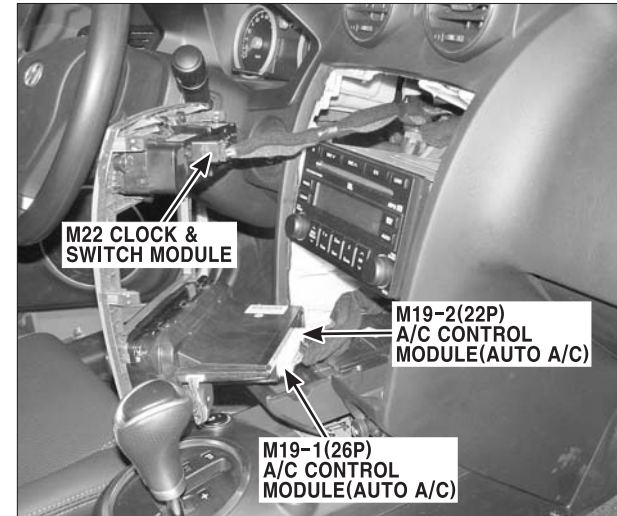

PHOTO.76



PHOTO.77



PHOTO.78

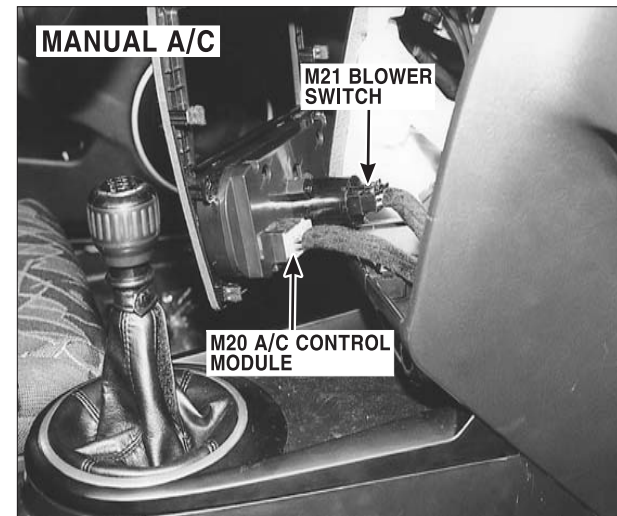

COMPONENT LOCATIONS

COMPONENT LOCATIONS (14)

CL-14

PHOTO.79

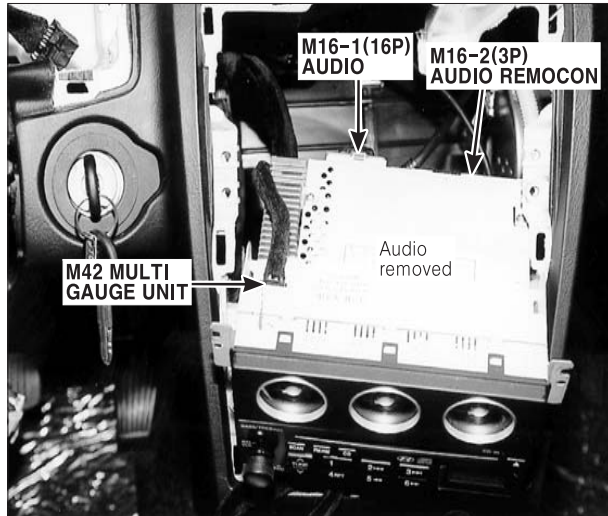

PHOTO.80

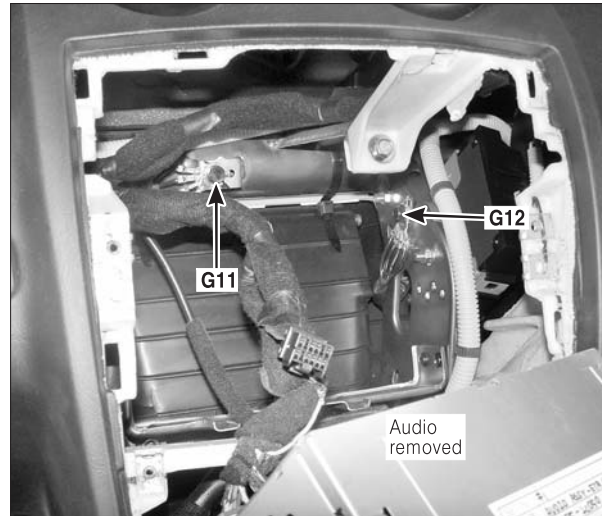

PHOTO.81

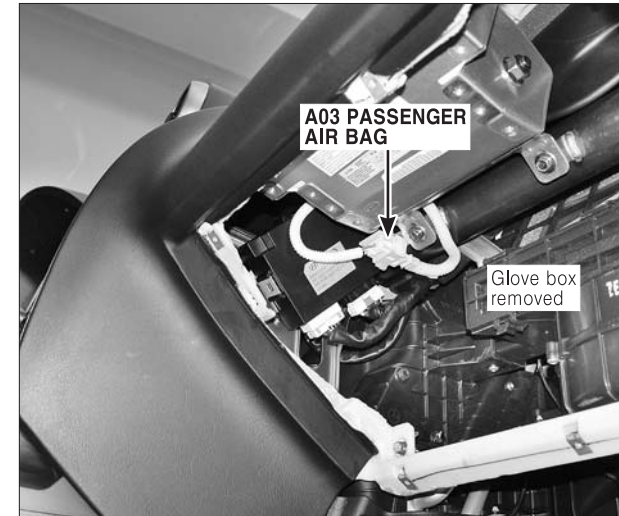

PHOTO.82



PHOTO.83



PHOTO.84

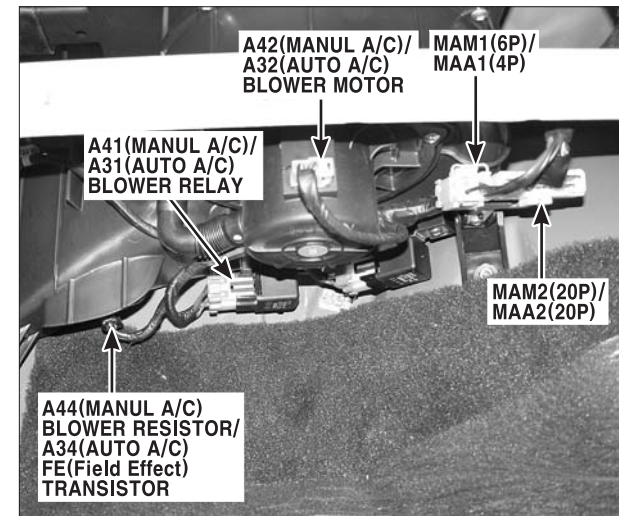

COMPONENT LOCATIONS

COMPONENT LOCATIONS (15)

CL-15

PHOTO.85

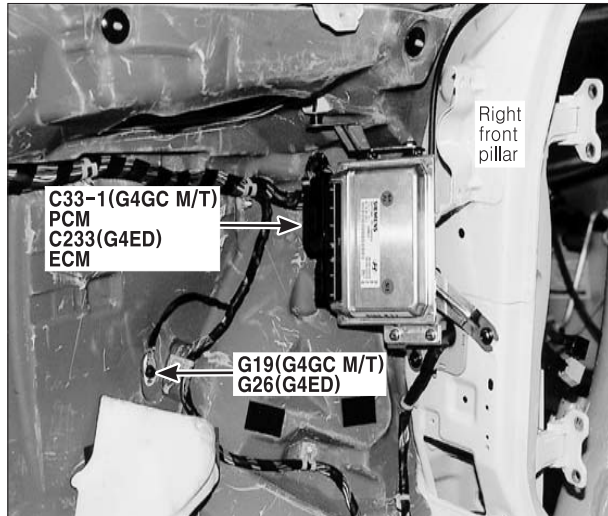

PHOTO.86

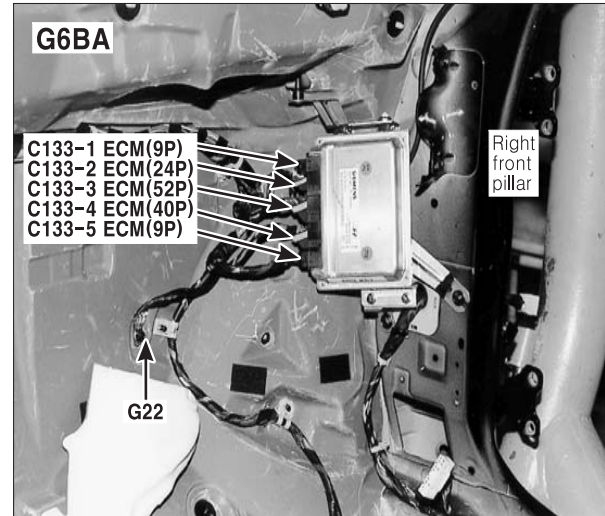

PHOTO.87

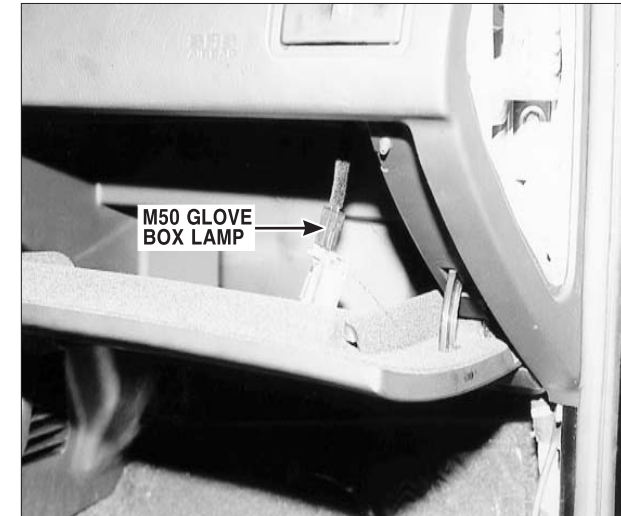

PHOTO.88

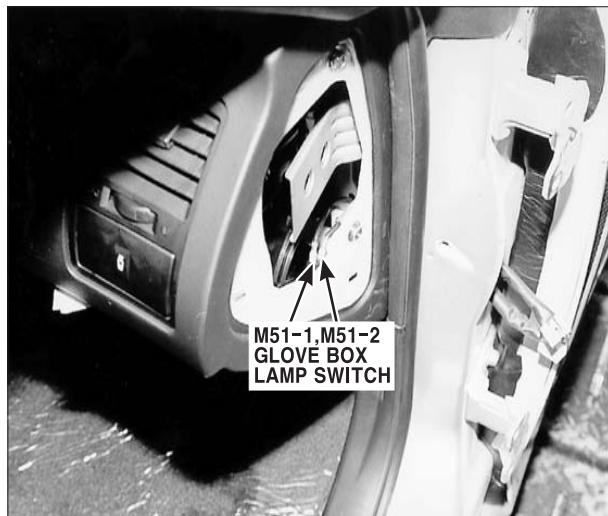

PHOTO.89

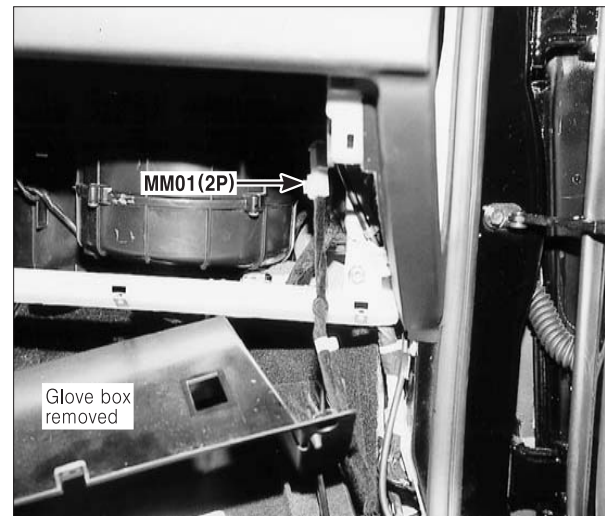
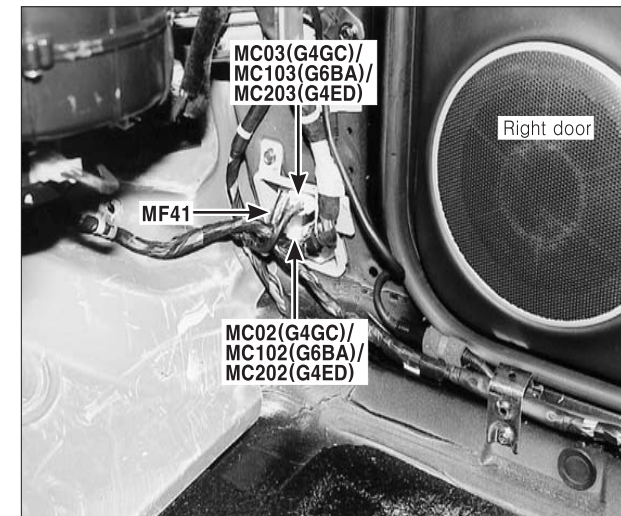

PHOTO.90



COMPONENT LOCATIONS

COMPONENT LOCATIONS (16)

CL-16

PHOTO.91

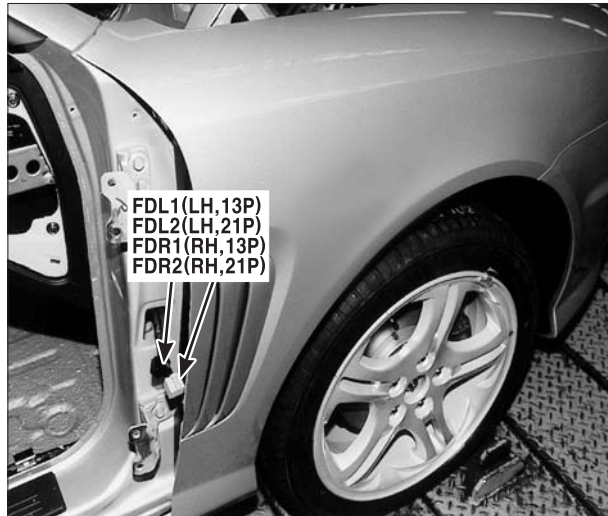

PHOTO.92



PHOTO.93

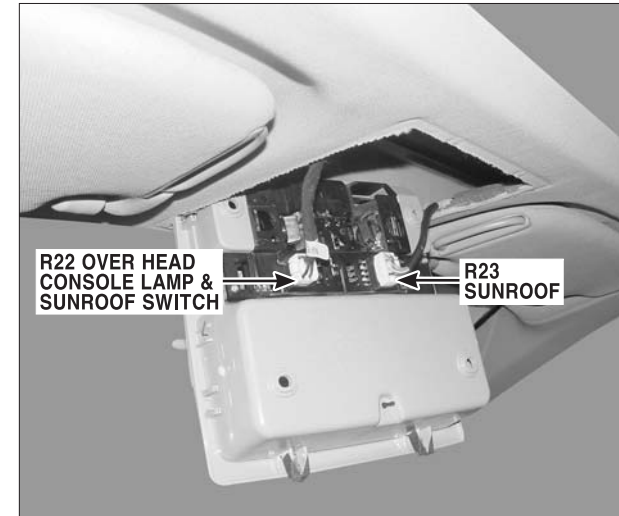

PHOTO.94

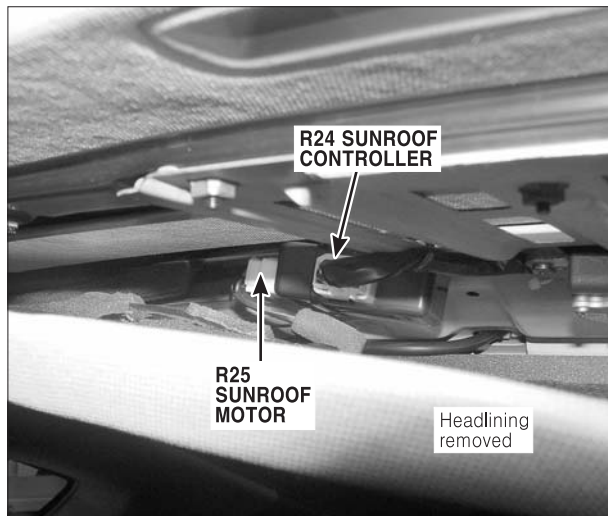

PHOTO.95

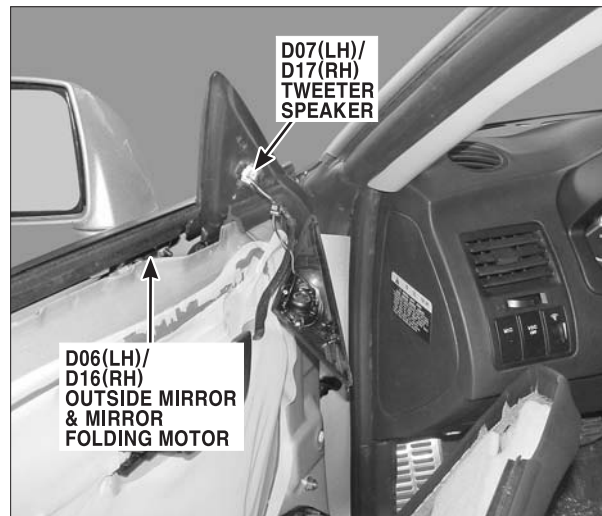
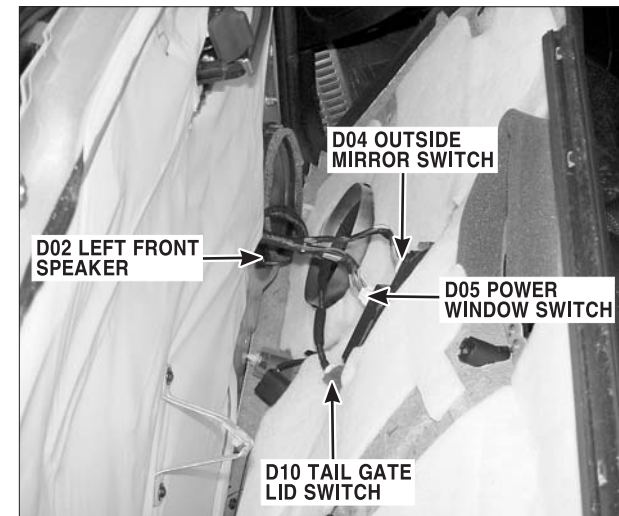

PHOTO.96



COMPONENT LOCATIONS

COMPONENT LOCATIONS (17)

CL-17

PHOTO.97

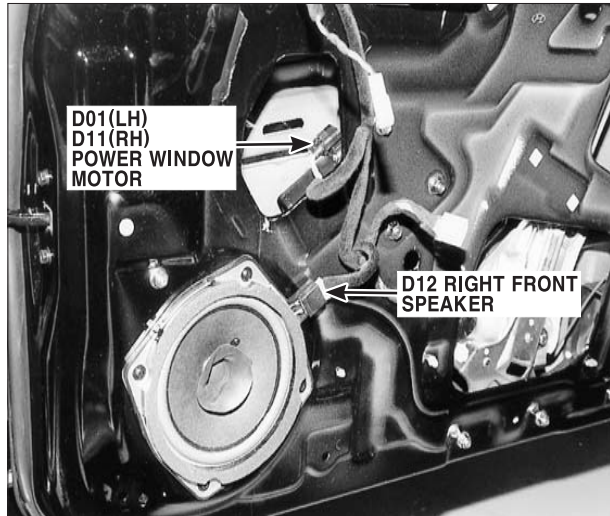

PHOTO.98



PHOTO.99

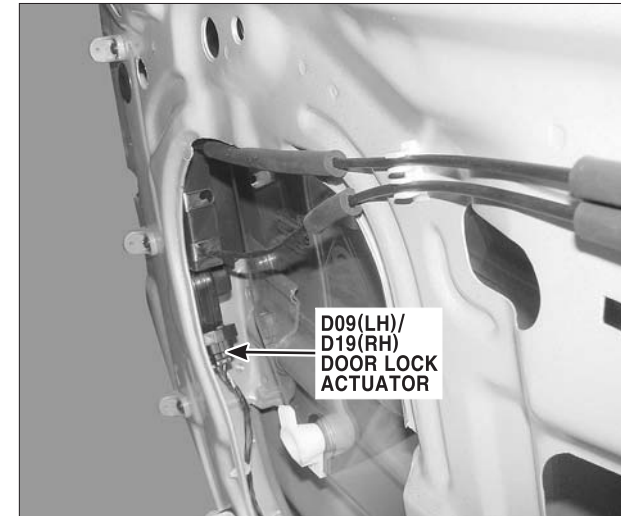

PHOTO.100

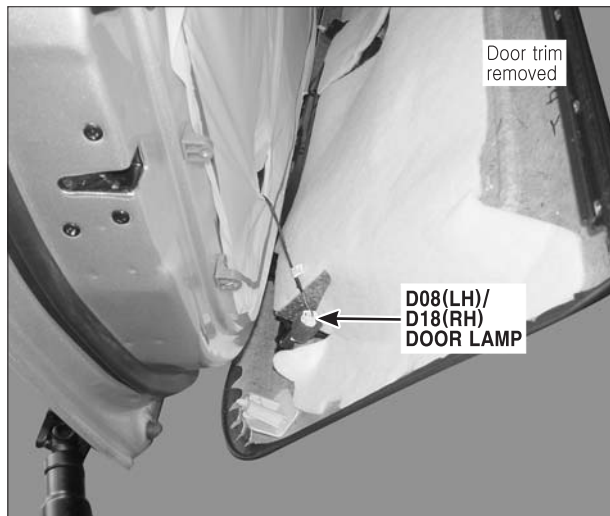

PHOTO.101

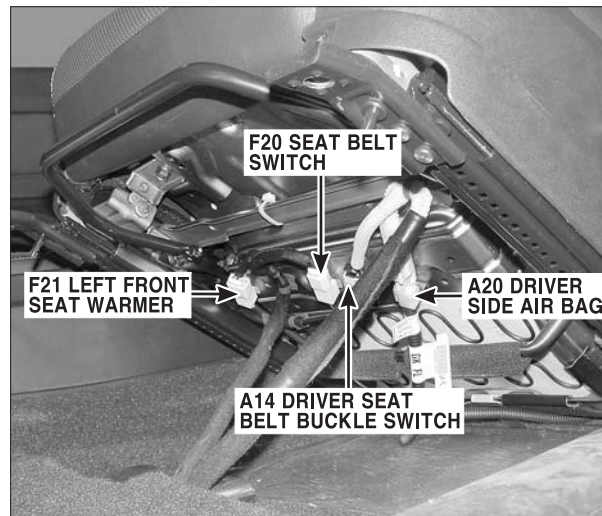
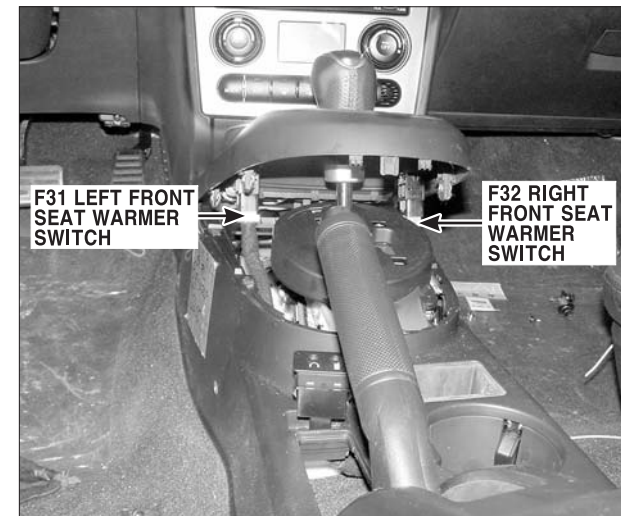

PHOTO.102



COMPONENT LOCATIONS

COMPONENT LOCATIONS (18)

CL-18

PHOTO.103

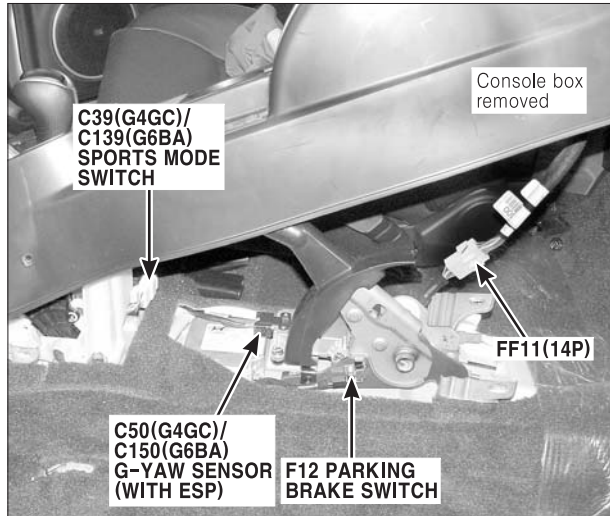

PHOTO.104

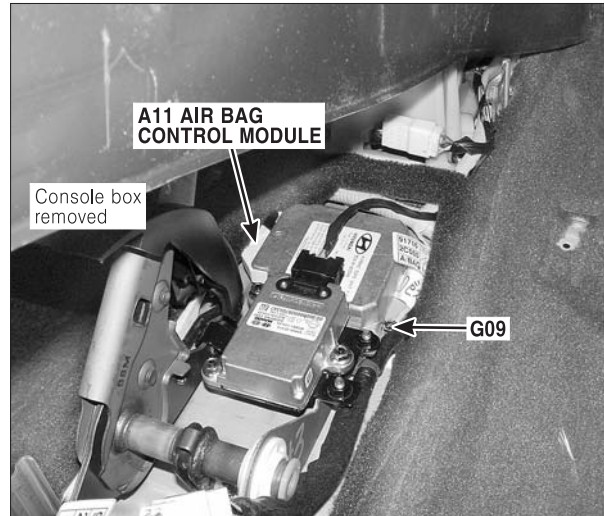

PHOTO.105



PHOTO.106

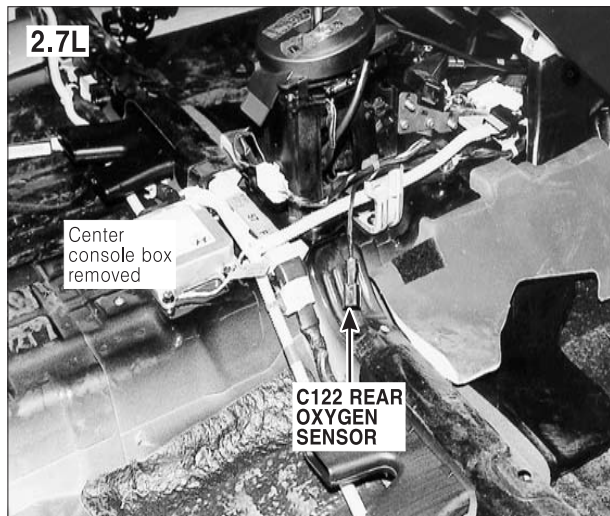

PHOTO.107

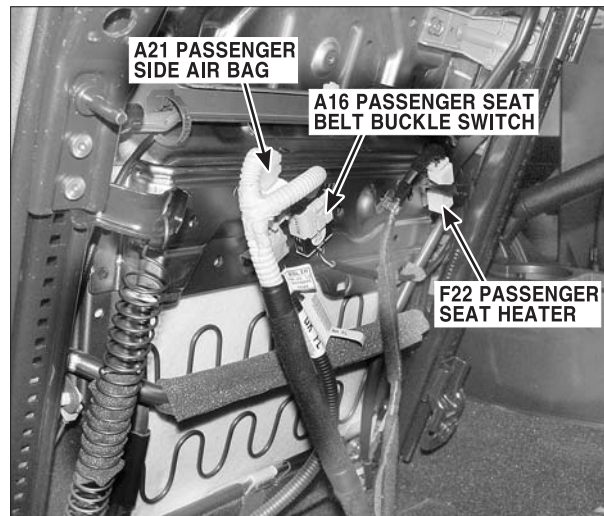
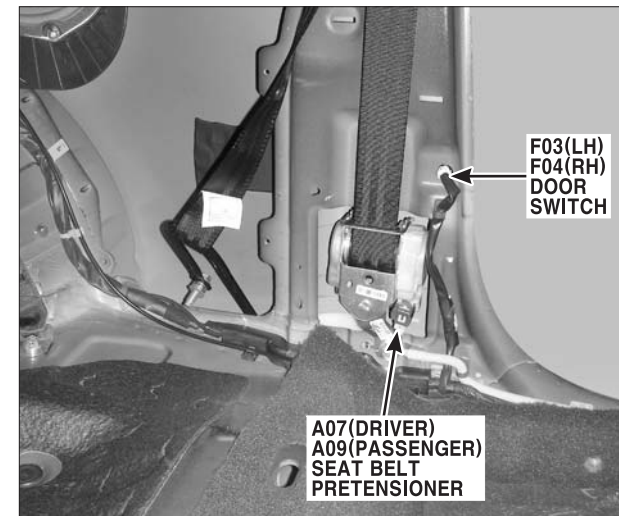

PHOTO.108



COMPONENT LOCATIONS

COMPONENT LOCATIONS (19)

CL-19

PHOTO.109

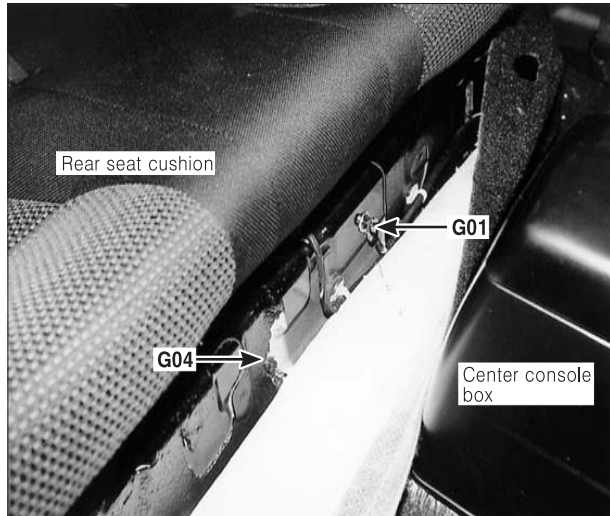

PHOTO.110

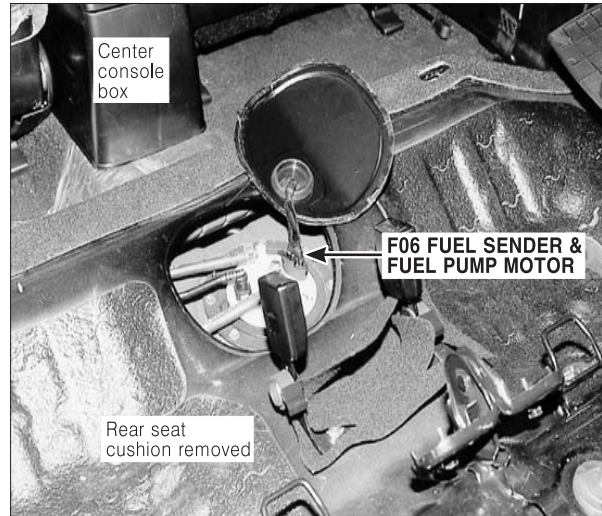

PHOTO.111

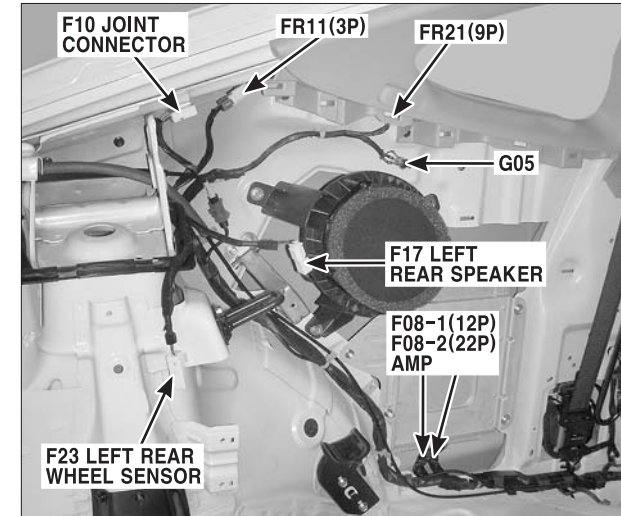

PHOTO.112

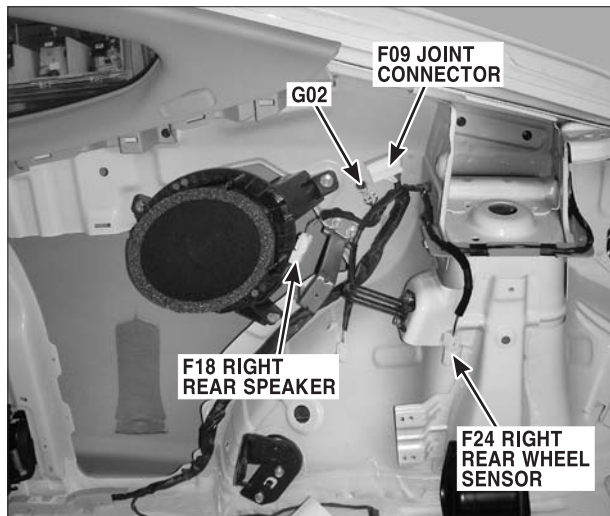

PHOTO.113

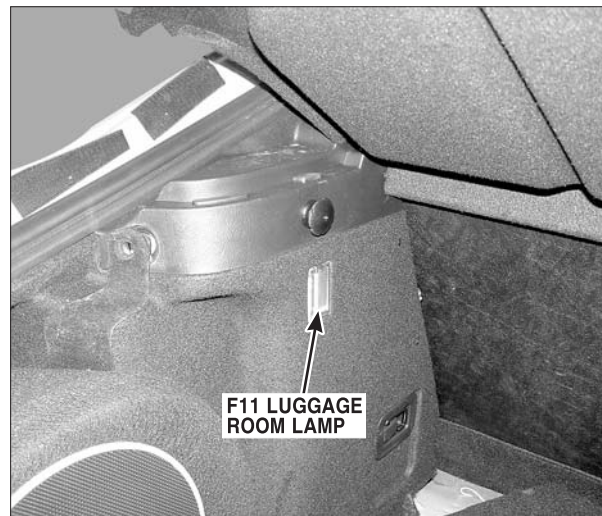
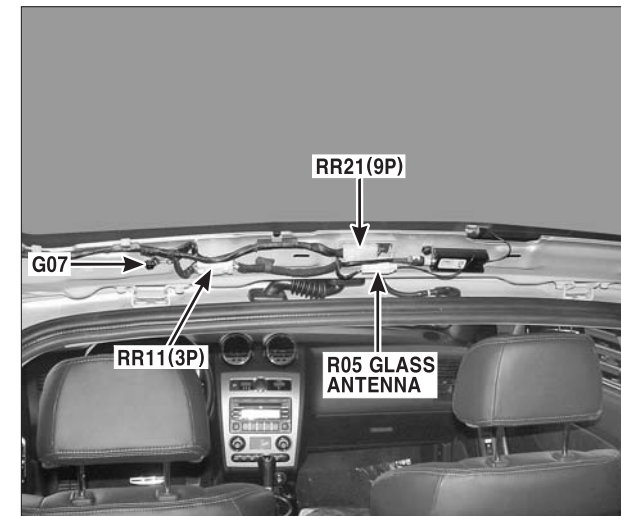

PHOTO.114



COMPONENT LOCATIONS

COMPONENT LOCATIONS (20)

CL-20

PHOTO.115

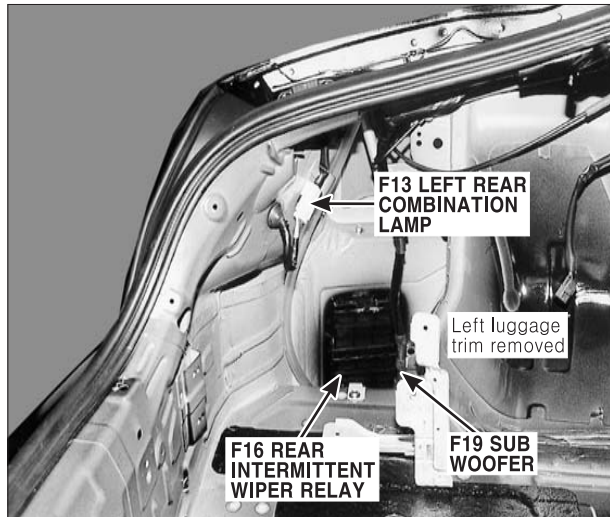

PHOTO.116

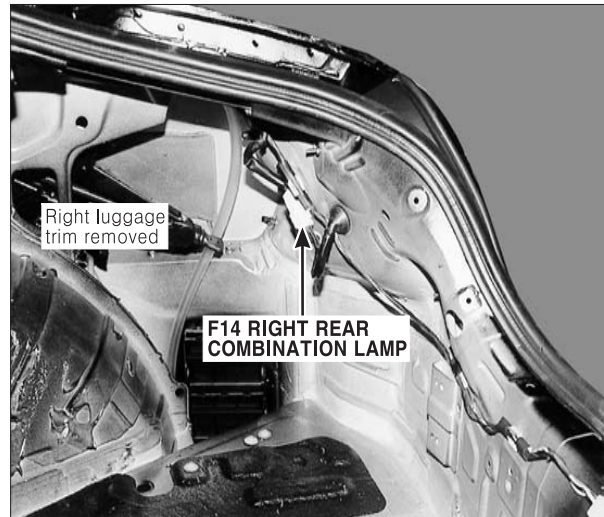

PHOTO.117



PHOTO.118



PHOTO.119



PHOTO.120

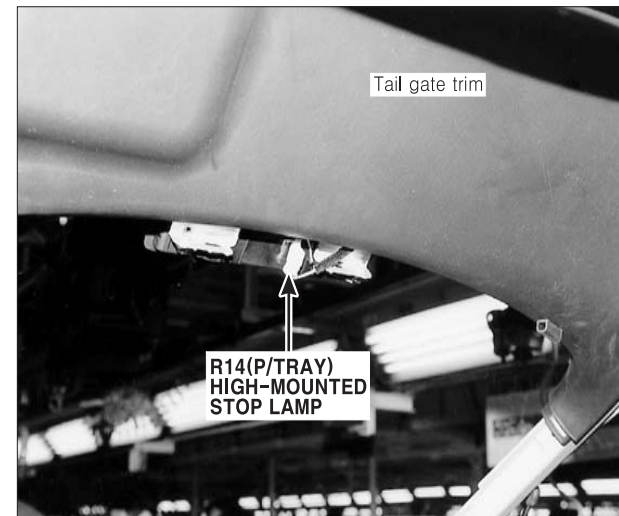

COMPONENT LOCATIONS

COMPONENT LOCATIONS (21)

CL-21

PHOTO.121

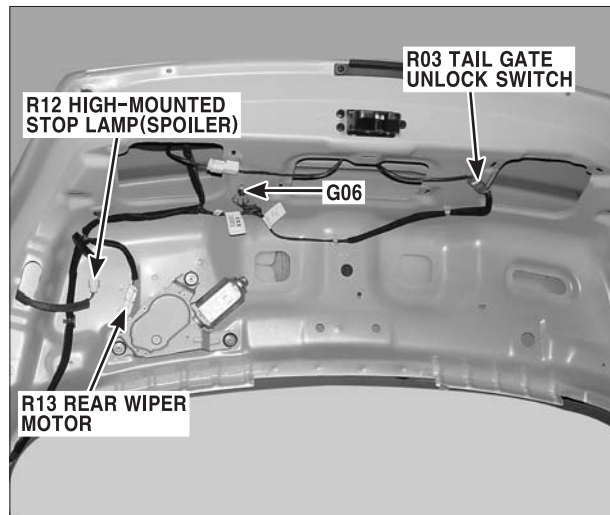
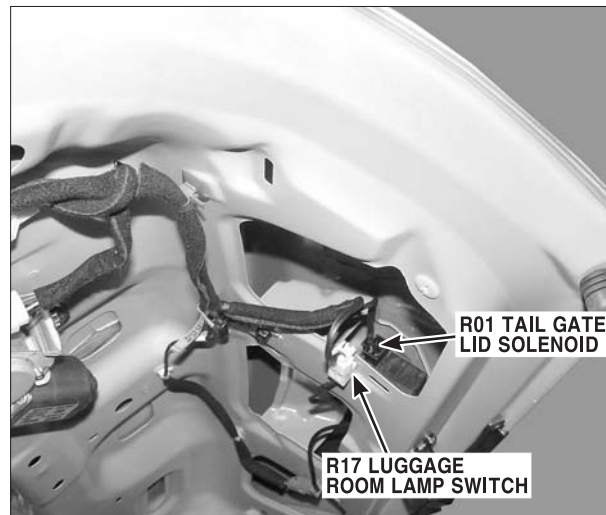
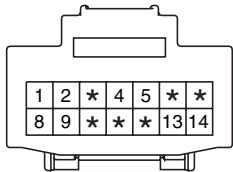
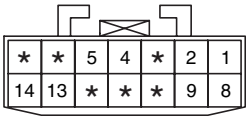
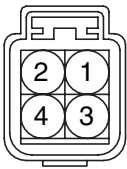
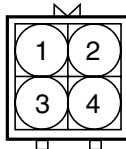
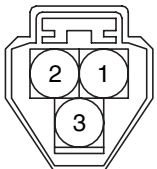
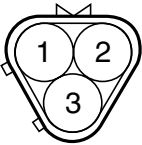
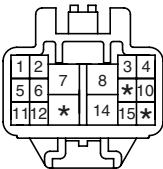
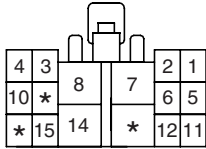
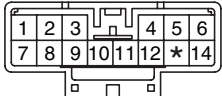
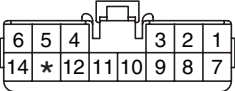
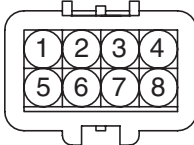
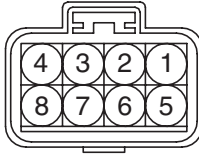
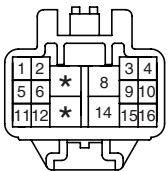
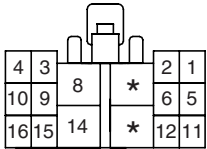
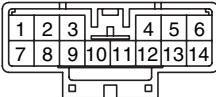
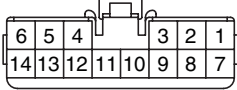
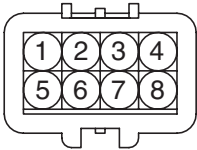
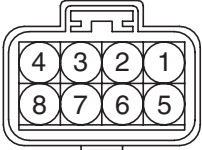
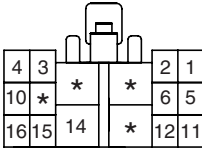
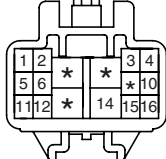

PHOTO.122



HARNESS CONNECTORS (1)		CC-1
<p>AA21</p>  <p>AMP_MQS_14M_Y</p>  <p>AMP_MQS_14F_Y</p>	<p>CC101</p>  <p>KUM_NMWP_04F_B</p>  <p>CR04M011</p>	
<p>CC201</p>  <p>KUM_NMWP_03F_B</p>  <p>CR03M024</p>	<p>EC01</p>  <p>KET_1809_16M_W</p>  <p>KET_1809_16F_W</p>	
<p>EC02</p>  <p>KET_090II_14M_W</p>  <p>KET_090II_14F_W</p>	<p>EC03</p>  <p>KUM_NMWP_08M_B</p>  <p>KUM_NMWP_08F_B</p>	
<p>EC101</p>  <p>KET_1809_16M_W</p>  <p>KET_1809_16F_W</p>	<p>EC102</p>  <p>KET_090II_14M_W</p>  <p>KET_090II_14F_W</p>	
<p>EC103</p>  <p>KUM_NMWP_08M_B</p>  <p>KUM_NMWP_08F_B</p>	<p>EC201</p>  <p>KET_1809_16F_W</p>  <p>KET_1809_16M_W</p>	

HARNES CONNECTORS

HARNES CONNECTORS (2)

CC-2

EC202

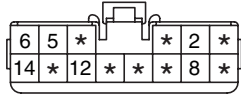

KET_090II_14F_W

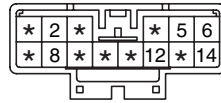

KET_090II_14M_W

EE01

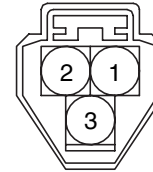

KUM_NMWP_03F_B

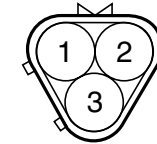

CR03M024

EE02

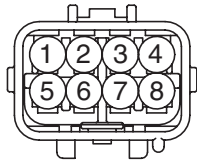

KET_090IWP_08M_W

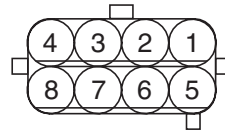

CR08F063

EE03

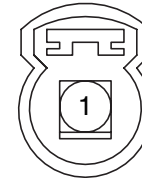

KUM_NMWP_01F_B

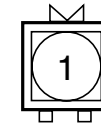

CR01M002

EM01

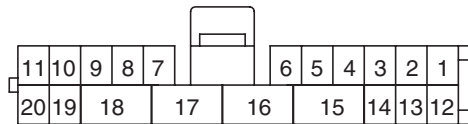

KET_2507_20F_W

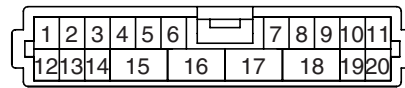

KET_2507_20M_W

EM02

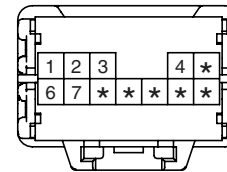

KET_040III_12M

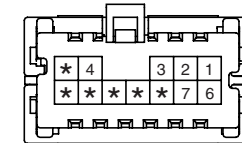

KET_040III_12F_W

FDL1

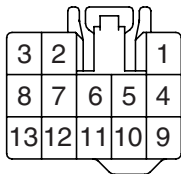

KET_090III_13F_Gr

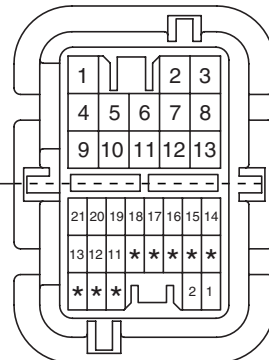

KET_DOOR_34M_W

FDR1

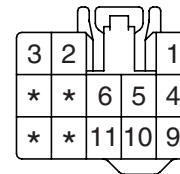

KET_090III_13F_Gr

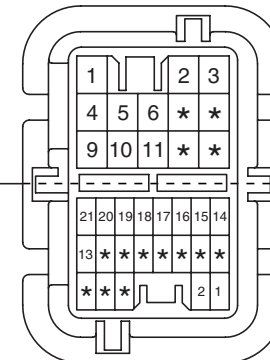

KET_DOOR_34M_W

FDL2

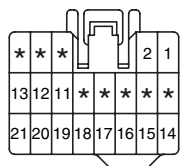

KET_050_21F_B

FDR2

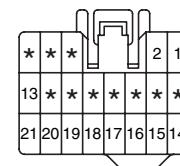

KET_050_21F_B

HARNES CONNECTORS

HARNES CONNECTORS (3)

CC-3

FF11

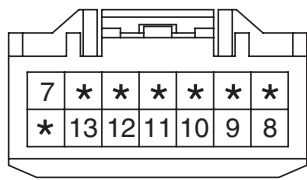

AMP_090III_14F_W

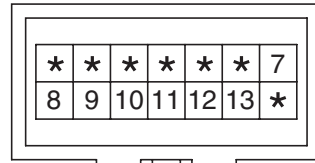

AMP_090III_14M_W

FR11

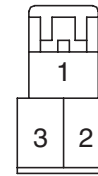

KUM_DSD_03F_W

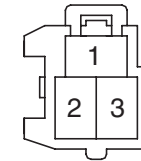

KUM_DSD_03M_W_CLIP

FR21

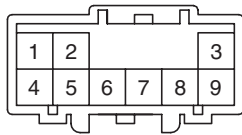

KUM_CDR_09M_W

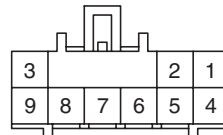

KUM_CDR_09F_W

MAA1

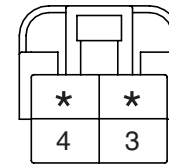

KET_250DL_04F_W

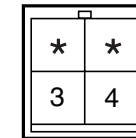

CR04M010

MAA2

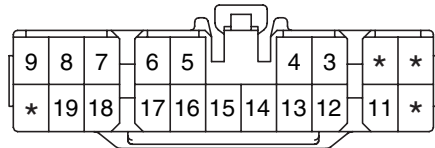

KET_090II_20F_W

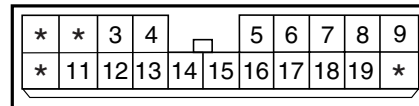

CR20M002

MAM1

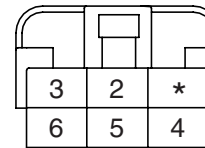

KET_250DL_06F_W

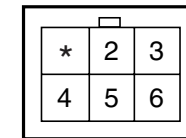

CR06M005

MAM2

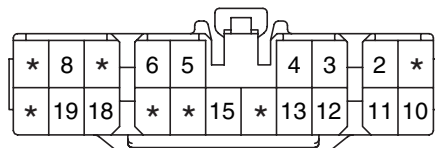

KET_090II_20F_W

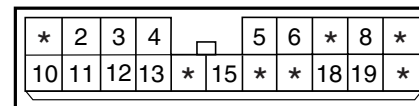

CR20M002

MC01

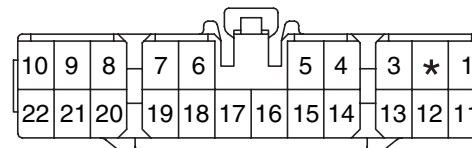

KET_090II_22F_W

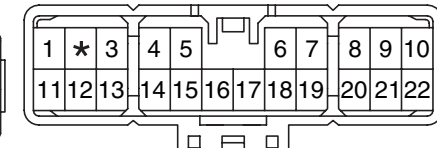

KET_090II_22M_W

MC02

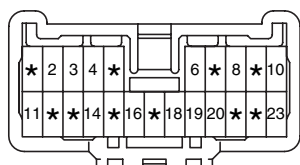

KET_050_23M_W

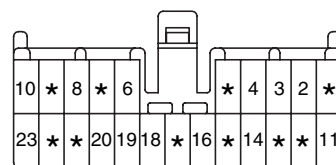

KET_050_23F_W

MC03

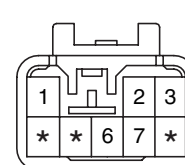

KET_090II_08M_W

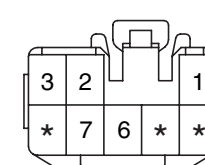

KET_090II_08F_W

HARNESS CONNECTORS

HARNESS CONNECTORS (4)

CC-4

MC101

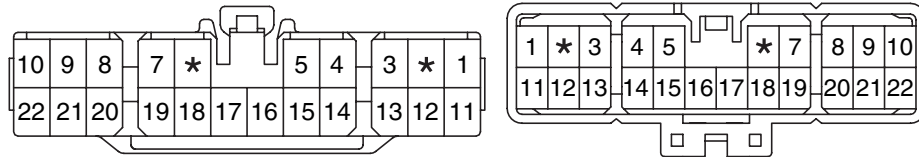

KET_090II_22F_W

KET_090II_22M_W

MC102

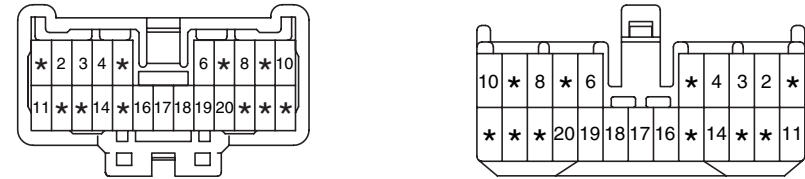

KET_050_23M_W

KET_050_23F_W

MC103



KET_090II_08M_W

KET_090II_08F_W

MC201

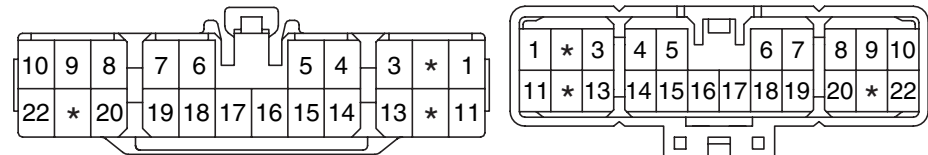

KET_090II_22F_W

KET_090II_22M_W

MC202

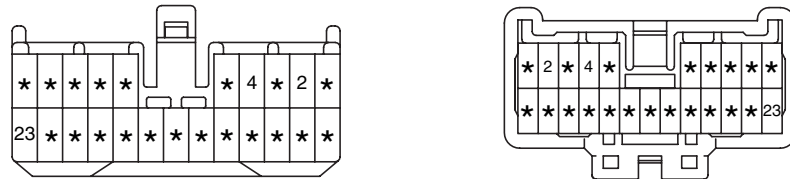

KET_050_23F_W

KET_050_23M_W

MC203



KET_090II_08F_W

KET_090II_08M_W

MF21



KET_050_18M_L

KET_050_18F_W

MF31



KET_090II_15M_W

KET_090II_15F_W

MF41

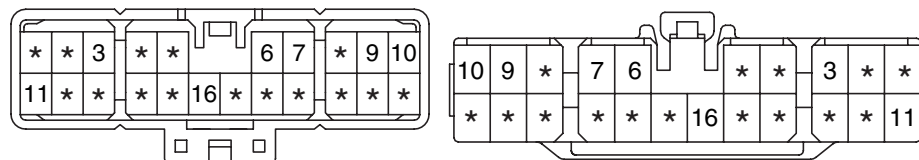

KET_090II_22M_W

KET_090II_22F_W

MM01



KET_090II_02F_W_L

KET_090II_02M_W_R

HARNES CONNECTORS

HARNES CONNECTORS (5)

CC-5

MR11

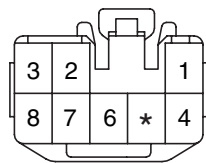

KET_090II_08F_L

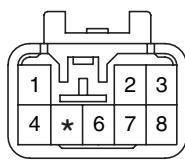

KET_090II_08M_L

RR11

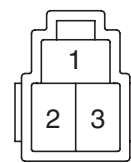

KET_250_03M_W

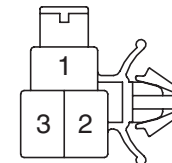

KET_250_03F_W

RR21

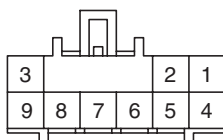

KUM_CDR_09F_W

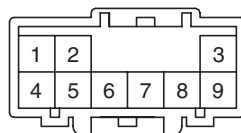

KUM_CDR_09M_W

BLANK

BCM CONNECTORS (1) **CC-6**

BCM-AA

AMP_JPT_10F_B

BCM-CE

AMP_JPT_18F_B

BCM-DE

AMP_250DL_01F_B

BCM-EF

AMP_040M2_12F_B

BCM-FF

AMP_JPT_22F_B

BCM-GF

AMP_SPT_02F_B

BCM-HM

AMP_040M1_20F_B

BCM-IM

AMP_040M2_20F_B

BCM-JM

AMP_040M2_16F_B

BCM-KM

AMP_JPT_14F_B

BCM-LM

AMP_250_08F_W

BCM-MR

AMP_JPT_08F_B

JOINT CONNECTORS (1)

CC-7

C41

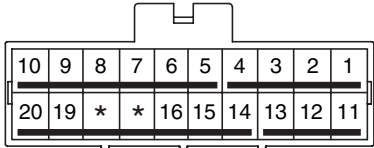

KET_090II_20F_B_JCH8

C42

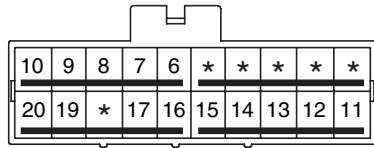

KET_090II_20F_B_JCH4

C141

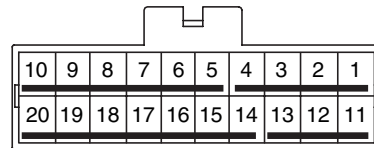

KET_090II_20F_B_JCH8

C142

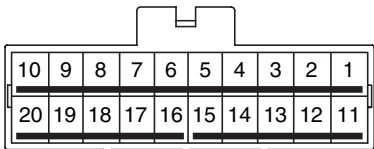

KET_090II_20F_B_JCH8

C241

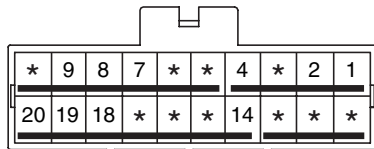

KET_090II_20F_B_JCH8

C242

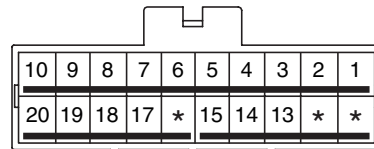

KET_090II_20F_B_JCH8

F09

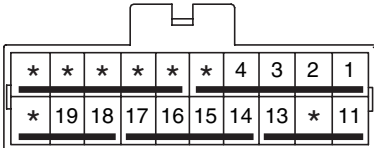

KET_090II_20F_B_JCH

F10

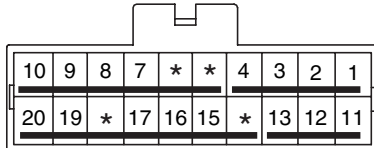

KET_090II_20F_B_JCH

M33

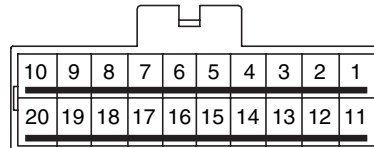

KET_090II_20F_B_JCH

M34

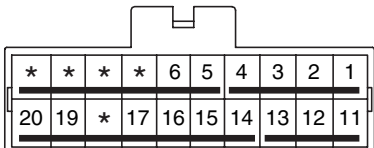

KET_090II_20F_B_JCH

M35

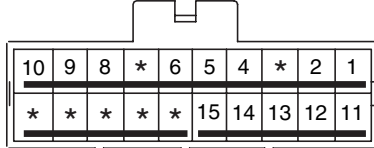

KET_090II_20F_B_JCH

M36

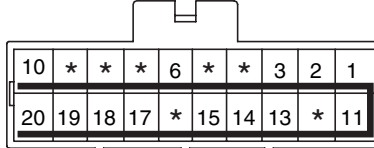

KET_090II_20F_B_JCH

BLANK

E56

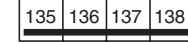
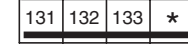
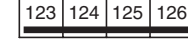
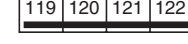
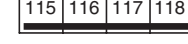
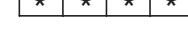
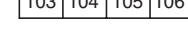
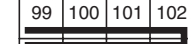
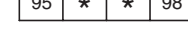
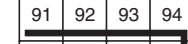
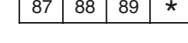
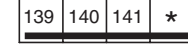
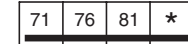

KET_FRBOX_150F_B

MAIN HARNESS (1)

HL-1

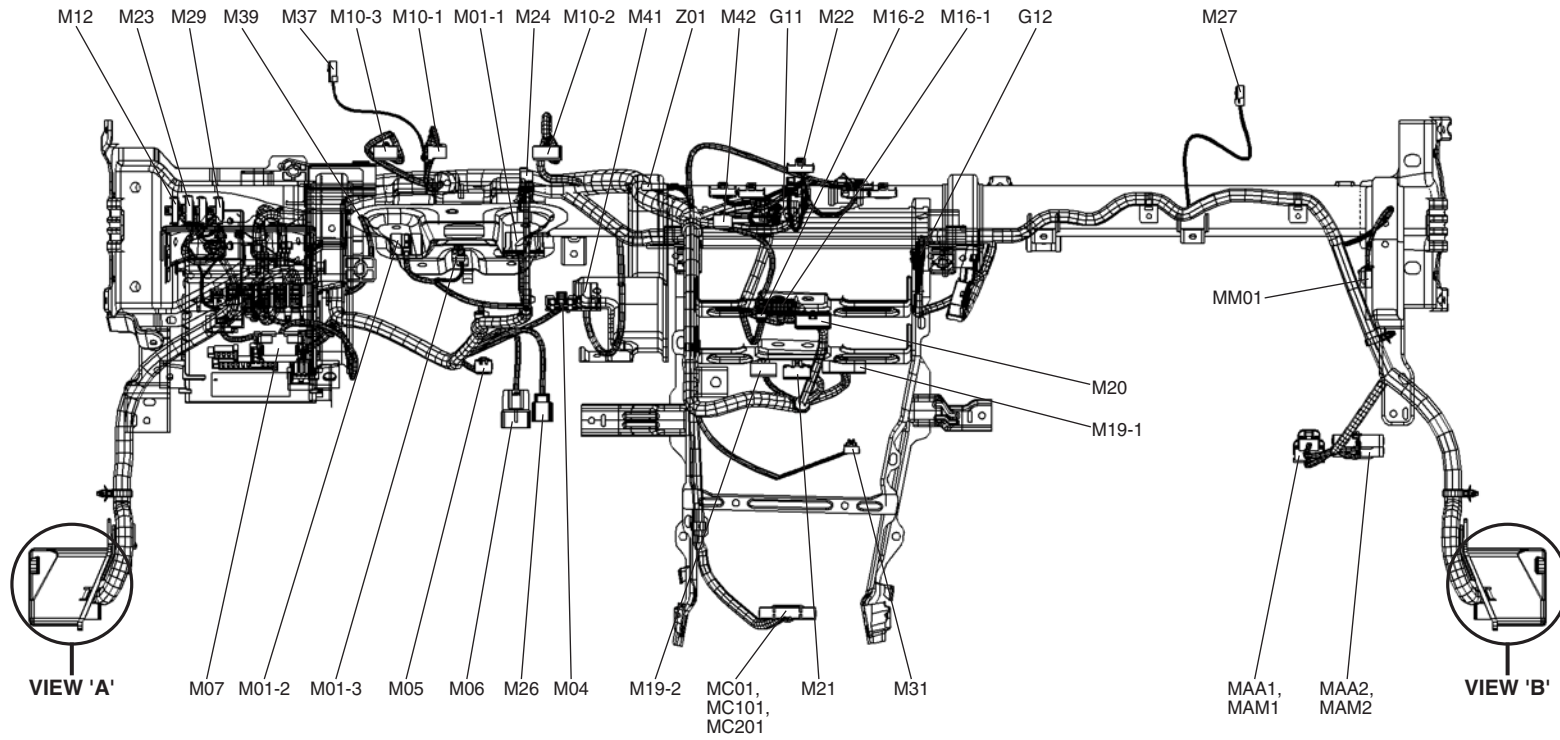

Back side of the crash pad

VIEW 'A'

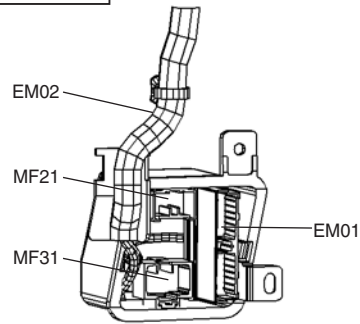

VIEW 'B'

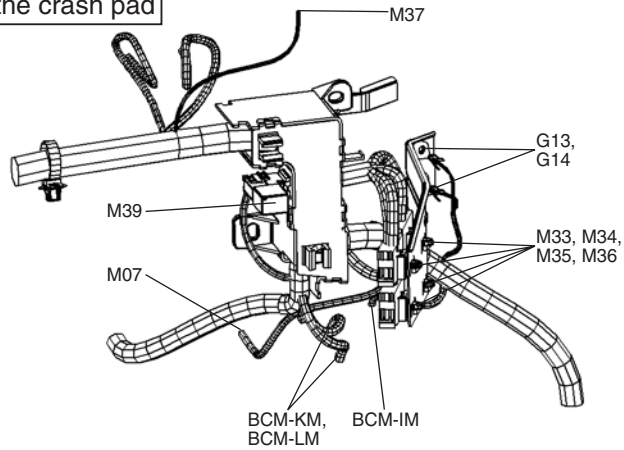

MC03, MC103, MC203

MF41

MC02, MC102, MC202

MAIN HARNESS

MAIN HARNESS (2)

HL-2

MAIN HARNESS

M01-1	Multifunction switch (LHD)
M01-2	Multifunction switch (LHD)
M01-3	Multifunction switch (Remocon SW)
M02-1	Multifunction switch (RHD)
M02-2	Multifunction switch (RHD)
M04	Ignition switch
M05	Key remind switch
M06	Multipurpose check connector
M07	Data link connector
M10-1	Instrument cluster
M10-2	Instrument cluster
M10-3	Instrument cluster
M12	Head lamp leveling switch
M16-1	Audio
M16-2	Audio remocon
M19-1	A/C control module (Auto A/C)
M19-2	A/C control module (Auto A/C)
M20	A/C control module (Manual A/C)
M21	Blower switch (Manual A/C)
M22	Clock & switch module
M23	ESP switch
M24	Steering angle sensor
M26	Vertical resistor (W/O ESP)
M27	Auto light sensor
M29	Rheostat
M31	Cigarette lighter
M33	Joint connector
M34	Joint connector
M35	Joint connector
M36	Joint connector
M37	Photo sensor (Auto A/C)
M39	Burglar alarm horn relay
M41	Burglar alarm relay
M42	Multi gauge unit
BCM-HM	Connection with BCM MODULE harness
BCM-IM	Connection with BCM MODULE harness

BCM-JM	Connection with BCM MODULE harness
BCM-KM	Connection with BCM MODULE harness
BCM-LM	Connection with BCM MODULE harness
BCM-MR	Connection with BCM MODULE harness (RHD)
EM01	Connection with ENGINE harness
EM02	Connection with ENGINE harness
MAA1	Connection with A/C harness (Auto A/C)
MAA2	Connection with A/C harness (Auto A/C)
MAM1	Connection with A/C harness (Manual A/C)
MAM2	Connection with A/C harness (Manual A/C)
MC01	Connection with CONTROL harness (G4GC)
MC02	Connection with CONTROL harness (G4GC)
MC03	Connection with CONTROL harness (G4GC)
MC101	Connection with CONTROL harness (G6BA)
MC102	Connection with CONTROL harness (G6BA)
MC103	Connection with CONTROL harness (G6BA)
MC201	Connection with CONTROL harness (G4ED)
MC202	Connection with CONTROL harness (G4ED)
MC203	Connection with CONTROL harness (G4ED)
MF21	Connection with FLOOR harness
MF31	Connection with FLOOR harness
MF41	Connection with FLOOR harness
MM01	Connection with GLOVE BOX harness
MR11	Connection with ROOF harness (RHD)
G11	Ground
G12	Ground
G13	Ground
G14	Ground
Z01	Diode

GLOVE BOX HARNESS

M50	GLOVE BOX LAMP
M51-1	GLOVE BOX LAMP SWITCH
M51-2	GLOVE BOX LAMP SWITCH
MM01	Connection with MAIN harness

FLOOR HARNESS (1)

HL-3

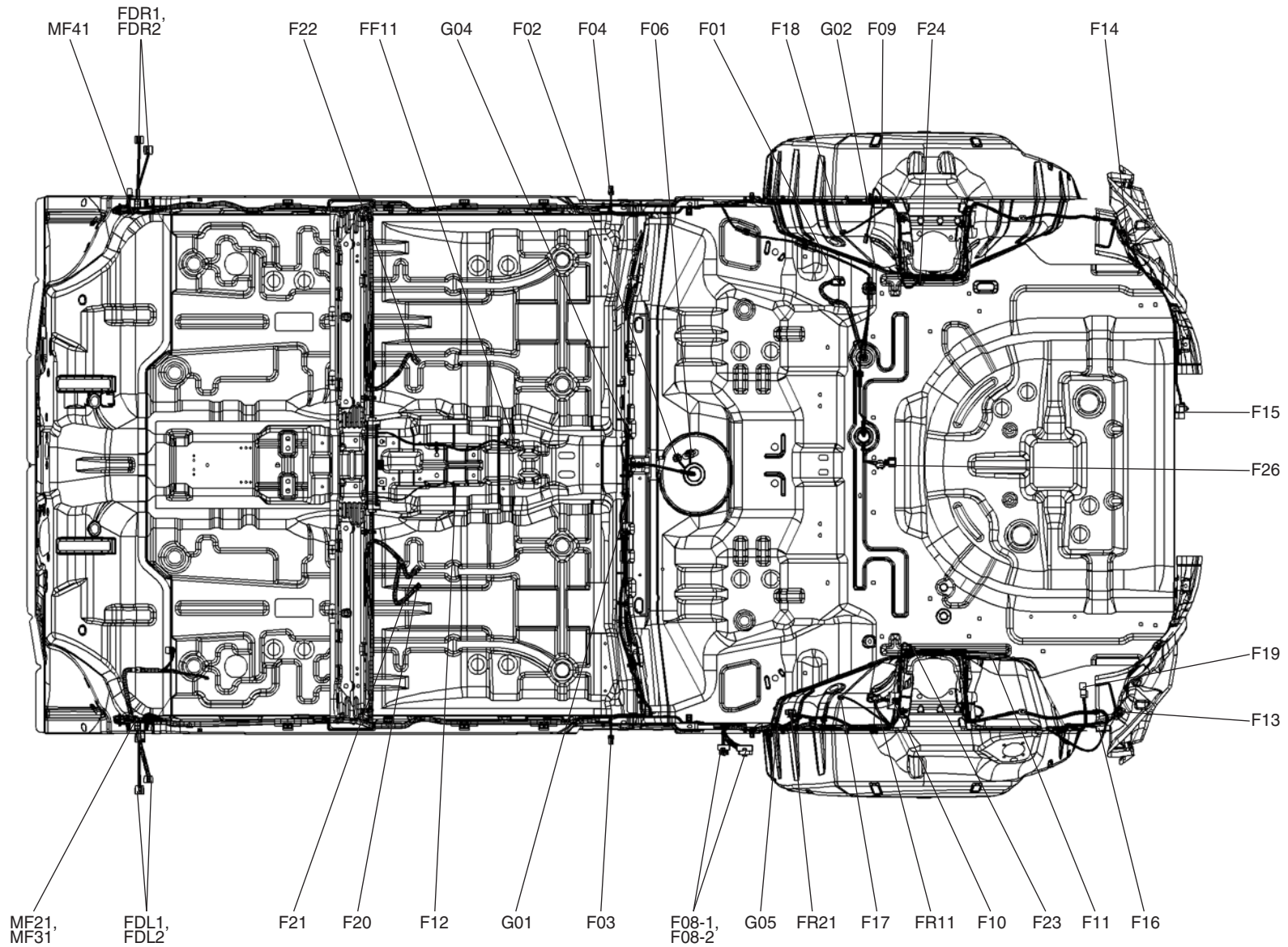

FLOOR HARNESS

FLOOR HARNESS (2)

HL-4

FLOOR HARNESS

F03	Left door switch
F04	Right door switch
F06	Fuel sender & Fuel pump motor
F08-1	AMP
F08-2	AMP
F09	Joint connector
F10	Joint connector
F11	Luggage room lamp
F12	Parking brake switch
F13	Left rear combination lamp
F14	Right rear combination lamp
F15	License lamp & Rear fog lamp
F16	Rear intermittent wiper relay
F17	Left rear speaker
F18	Right rear speaker
F19	Sub woofer
F20	Seat belt switch
F21	Left front seat warmer
F22	Right front seat warmer
F23	Left rear wheel sensor
F24	Right rear wheel sensor
BCM-EF	Connection with BCM MODULE harness
BCM-FF	Connection with BCM MODULE harness
BCM-GF	Connection with BCM MODULE harness
FDL1	Connection with LEFT DOOR harness
FDL2	Connection with LEFT DOOR harness
FDR1	Connection with RIGHT DOOR harness
FDR2	Connection with RIGHT DOOR harness
FF11	Connection with CONSOLE EXT. harness
FR11	Connection with TAIL GATE EXT. harness
FR21	Connection with TAIL GATE EXT. harness

MF21	Connection with MAIN harness
MF31	Connection with MAIN harness
MF41	Connection with MAIN harness
G01	Ground
G02	Ground
G04	Ground
G05	Ground

CONSOLE EXT. HARNESS

F31	Left front seat warmer switch
F32	Right front seat warmer switch
FF11	Connection with FLOOR harness

CONSOLE EXT. HARNESS

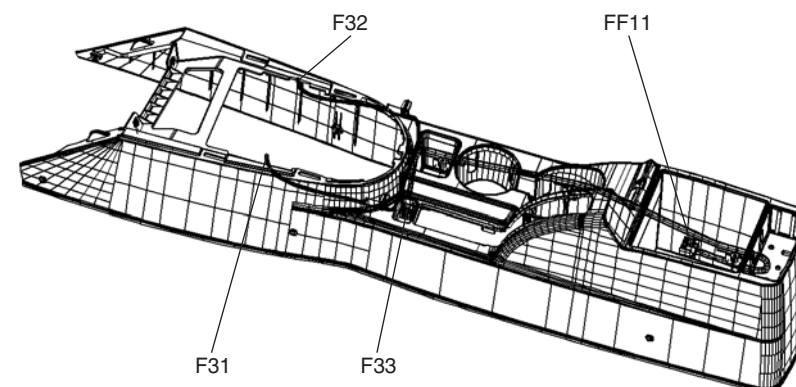

ENGINE HARNESS (1)

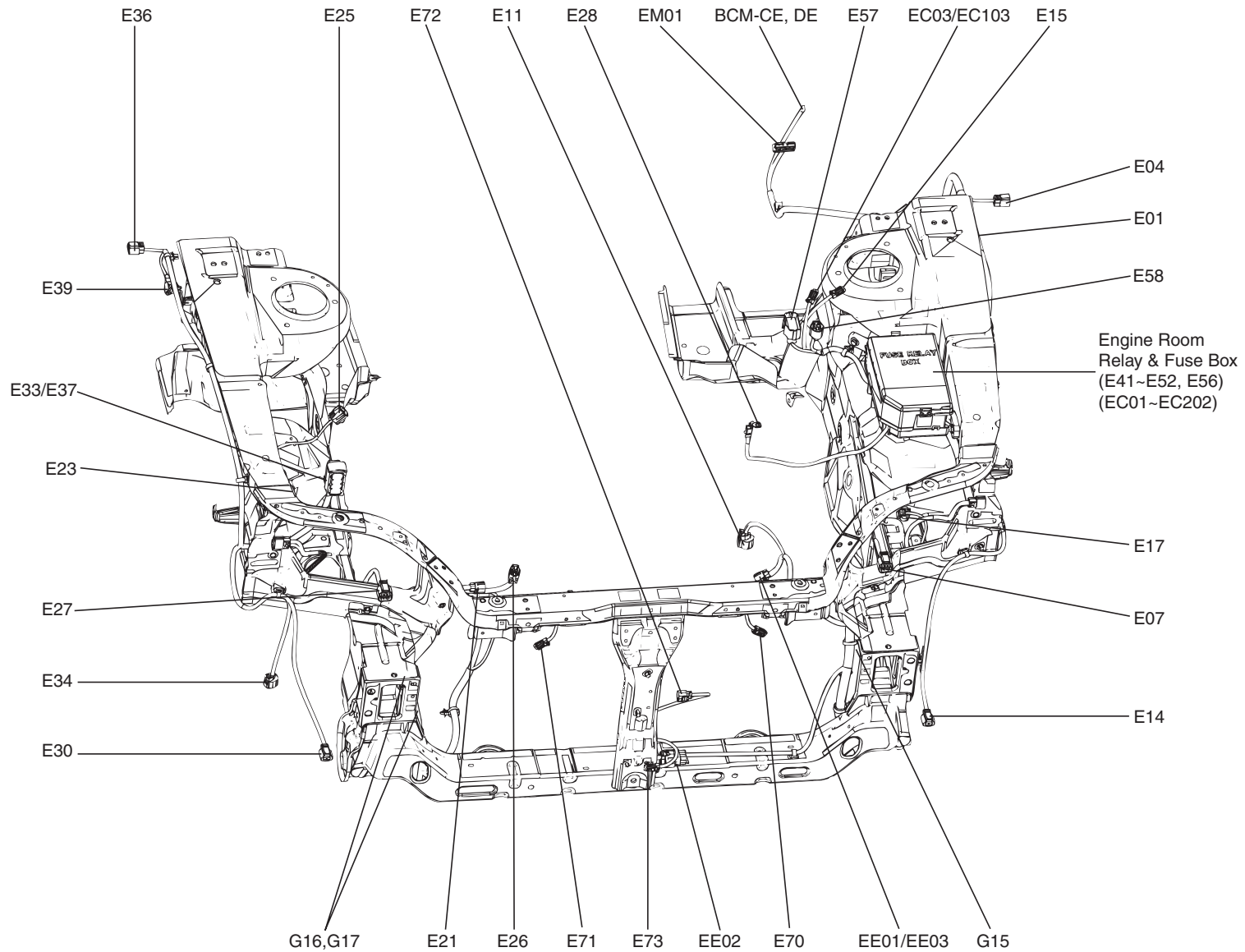

ENGINE HARNESS

E01 Left front wheel sensor
 E04 Left side repeater lamp
 E07 Left head lamp
 E08 Left head lamp leveling actuator
 E09 Right head lamp leveling actuator
 E11 Radiator fan motor
 E14 Left front fog lamp
 E17 Burglar alarm horn
 E20-1 Generator (B+) (G4ED/G4GC)
 E20-2 Generator (L, S) (G4ED/G4GC)
 E21 Condenser fan motor
 E23 ESP air bleeding connector
 E25 Triple switch (G4ED/G4GC)
 E26 Triple switch (G6BA)
 E27 Right head lamp
 E28 Battery (B+) terminal (G6BA)
 E28-1 Battery (B+) terminal (G4ED/G4GC)
 E30 Right front fog lamp
 E33 ESP control module
 E34 Front & rear washer motor
 E36 Right side repeater lamp
 E37 ABS control module
 E39 Right front wheel sensor
 E41 Start relay
 E42 Main relay
 E43 COND.2 relay
 E44 RAD relay
 E45 Horn relay
 E46 Wiper relay
 E47 F/Fog relay
 E48 H/LP (Lo) relay
 E49 F/PUMP relay
 E50 A/CON relay
 E51 H/LP (Hi) relay
 E52 COND.1 relay
 E56 Joint connector
 E57 DRL control module

BCM-CE Connection with BCM MODULE harness
 BCM-DE Connection with BCM MODULE harness
 EC01 Connection with CONTROL harness (G4GC)
 EC02 Connection with CONTROL harness (G4GC)
 EC03 Connection with CONTROL harness (G4GC)
 EC101 Connection with CONTROL harness (G6BA)
 EC102 Connection with CONTROL harness (G6BA)
 EC103 Connection with CONTROL harness (G6BA)
 EC201 Connection with CONTROL harness (G4ED)
 EC202 Connection with CONTROL harness (G4ED)
 EE01 Connection with BATTERY harness (G6BA)
 EE02 Connection with ENGINE EXT. harness
 EE03 Connection with BATTERY harness (G4ED/G4GC)
 EM01 Connection with MAIN harness
 EM02 Connection with MAIN harness
 G15 Ground
 G16 Ground
 G17 Ground

BATTERY HARNESS

E61-1 Generator (B+) (G6BA)
 E61-2 Generator (L, S) (G6BA)
 E62 Start solenoid (G6BA)
 E63 Start motor (B+) (G6BA)
 E67 Start solenoid (G4ED/G4GC)
 E68 Start motor (B+) (G4ED/G4GC)
 EE01 Connection with ENGINE harness (G6BA)
 EE03 Connection with ENGINE harness (G4ED/G4GC)

ENGINE EXT. HARNESS

E70 Left horn
 E71 Center horn
 E72 AQS sensor (Auto A/C)
 E73 Ambient temperature sensor
 EE02 Connection with ENGINE harness

AIR BAG HARNESS (1)

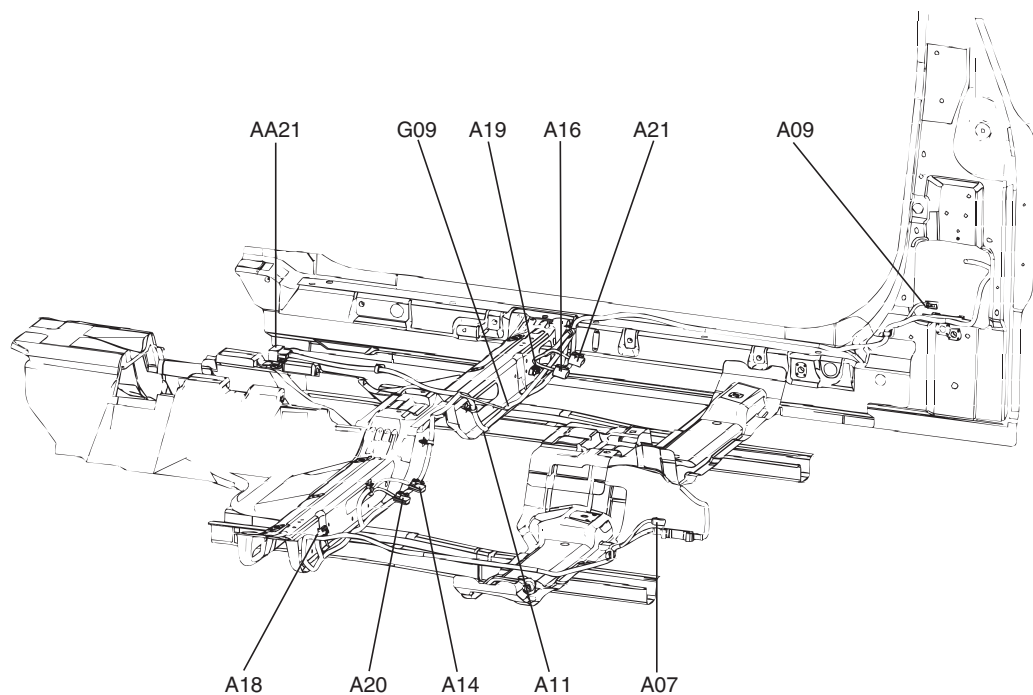

AIR BAG HARNESS

- A07 Driver seat belt pretensioner
- A09 Passenger seat belt pretensioner
- A11 SRS control module
- A14 Driver seat belt buckle switch
- A16 Passenger seat belt buckle switch
- A18 Driver satellite sensor
- A19 Passenger satellite sensor
- A20 Driver side air bag
- A21 Passenger side air bag
- AA21 Connection with AIR BAG EXT. harness
- G09 Ground

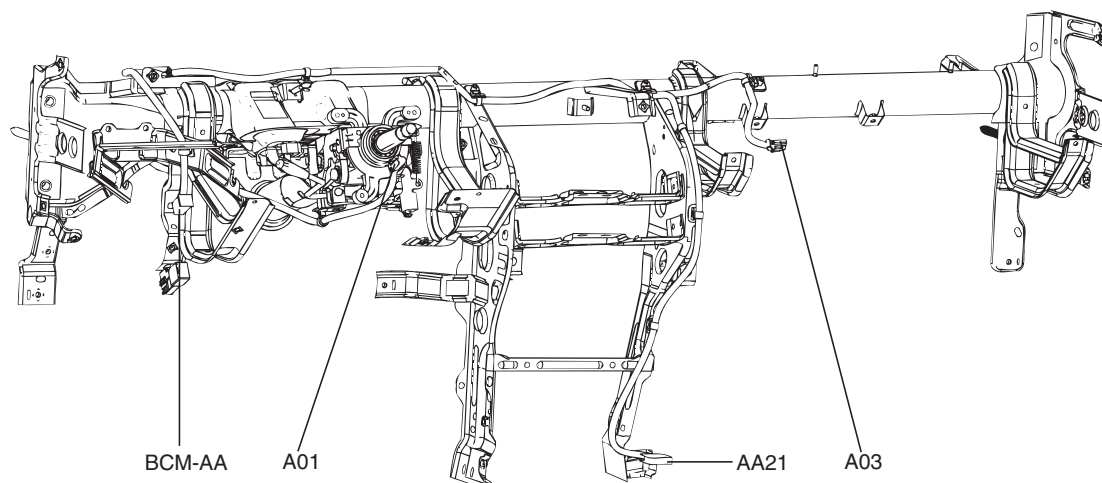

AIR BAG EXT.HARNESS

- A01 Driver air bag
- A03 Passenger air bag
- AA21 Connection with AIR BAG harness
- BCM-AI Connection with BCM MODULE harness

A/C HARNESS (1)

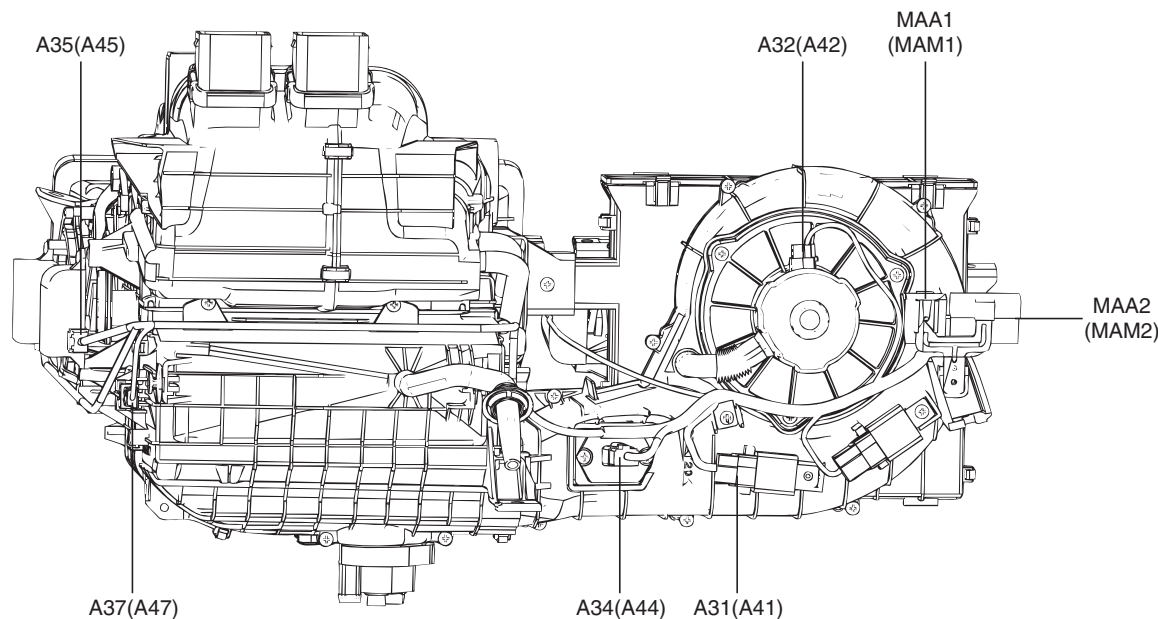

AUTO A/C HARNESS

- A31 Blower relay
- A32 Blower motor
- A33 Intake actuator
- A34 FE (Field Effect) transistor
- A35 Temperature actuator
- A36 Blend door actuator
- A37 Thermostatic switch (Thermistor)
- A38 Water temperature sensor
- MAA1 Connection with MAIN harness
- MAA2 Connection with MAIN harness

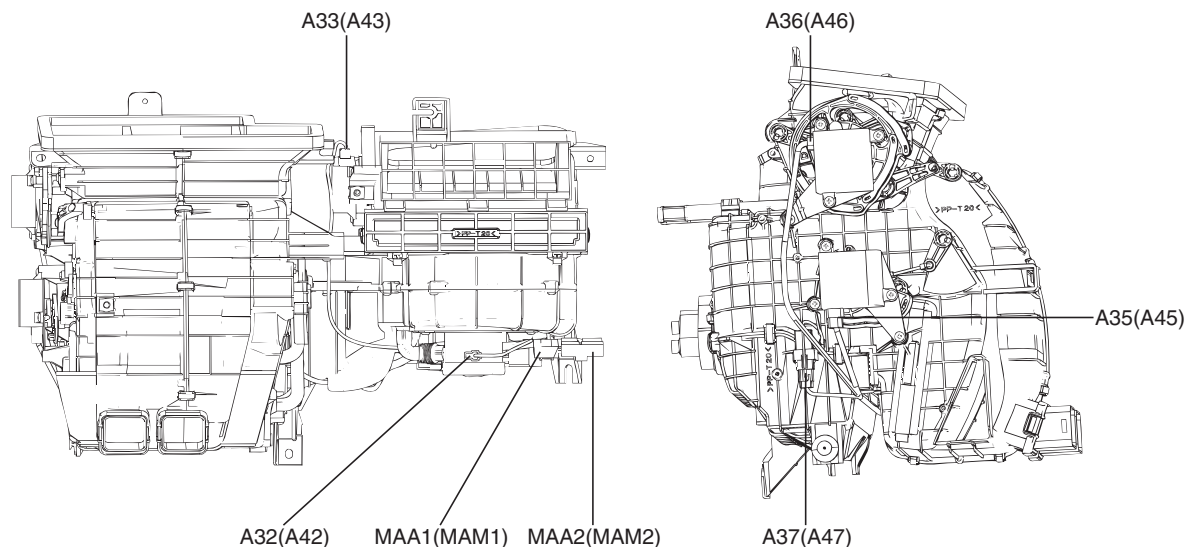

MANUAL A/C HARNESS

- A41 Blower relay
- A42 Blower motor
- A43 Intake actuator
- A44 Blower resistor
- A45 Temperature actuator
- A46 Blend door actuator
- A47 Thermostatic switch (Thermistor)
- MAM1 Connection with MAIN harness
- MAM2 Connection with MAIN harness

() : Manual A/C

CONTROL HARNESS (G4GC) (1)

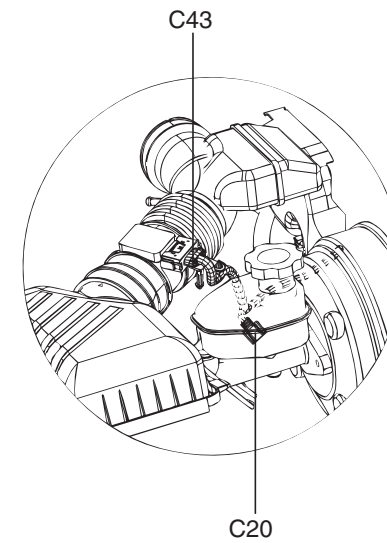
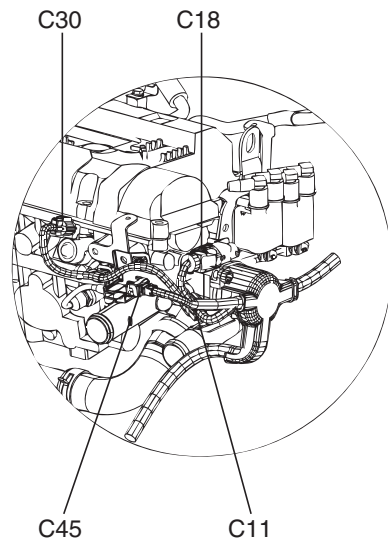
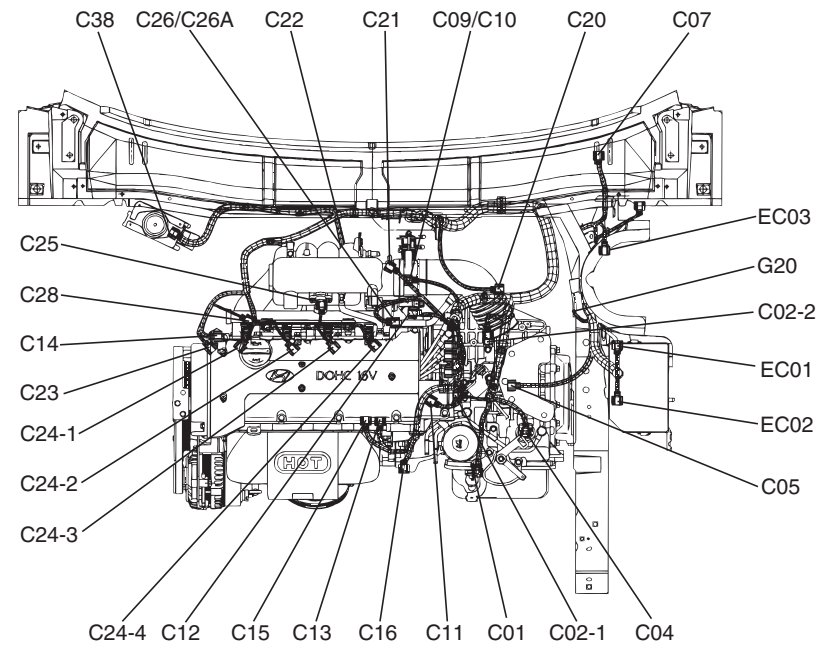
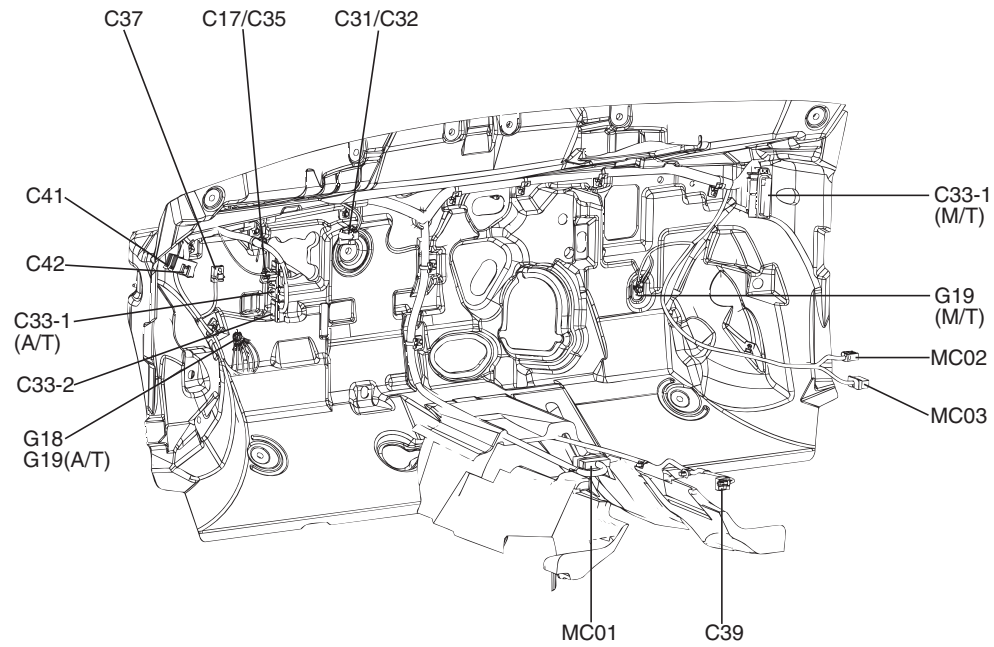

CONTROL HARNESS

CONTROL HARNESS (G4GC) (2)

HL-10

CONTROL HARNESS

C01	Transaxle range switch	C26-A	Idle speed control actuator (LEADED)
C02-1	A/T pulse generator 'A'	C28	A/C compressor
C02-2	A/T pulse generator 'B'	C29	Hood switch
C04	ATM solenoid valve	C30	Oil control valve (OCV)
C05	Back-up lamp switch (5M/T)	C31	Stop lamp switch (W/O ESP & cruise)
C06	Back-up lamp switch (6M/T)	C32	Stop lamp switch (With ESP & cruise)
C07	Front wiper motor (LHD)	C33-1	PCM
C08	Front wiper motor (RHD)	C33-2	PCM
C09	Vehicle speed sensor (A/T & 6M/T)	C35	Cruise clutch pedal position switch (M/T)
C10	Vehicle speed sensor (5M/T)	C37	A/T control relay
C11	Engine coolant temperature sensor & sender	C38	Cruise control module
C12	Throttle position sensor	C39	Sports mode switch
C13	Crankshaft position sensor	C41	Joint connector
C14	Camshaft position sensor	C42	Joint connector
C15	Oil pressure switch	C43	Mass air flow sensor (UNLEADED)
C16	Oxygen sensor (UP)	C45	Oil temperature sensor
C17	Ignition lock switch	C50	G-YAW sensor (With ESP)
C18	Ignition coil	C51	Pressure sensor (With ESP)
C20	Brake fluid level sensor	EC01	Connection with ENGINE harness
C21	Canister purge solenoid valve	EC02	Connection with ENGINE harness
C22	Oxygen sensor (DOWN)	EC03	Connection with ENGINE harness
C23	Knock sensor	MC01	Connection with MAIN harness
C24-1	Injector #1	MC02	Connection with MAIN harness
C24-2	Injector #2	MC03	Connection with MAIN harness
C24-3	Injector #3	G18	Ground (PCM)
C24-4	Injector #4	G19	Ground (ECM)
C25	Manifold absolute pressure sensor (LEADED)	G20	Ground (CONTROL)
C26	Idle speed control actuator (UNLEADED)		

CONTROL HARNESS

CONTROL HARNESS (G6BA) (1)

HL-11

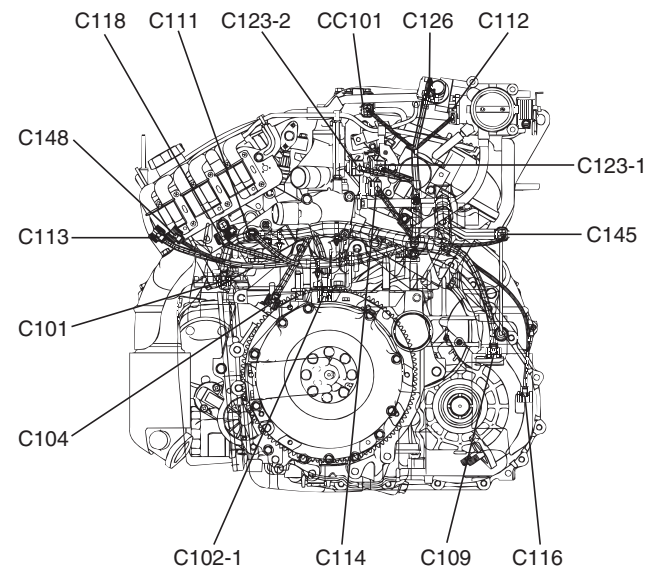
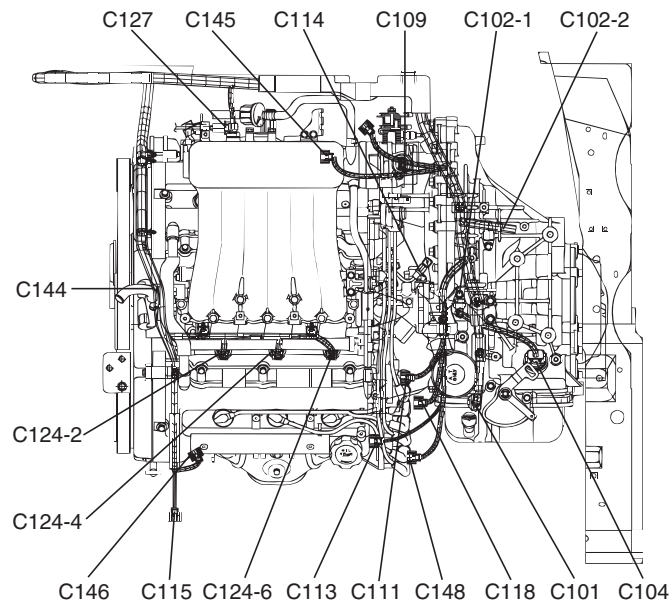
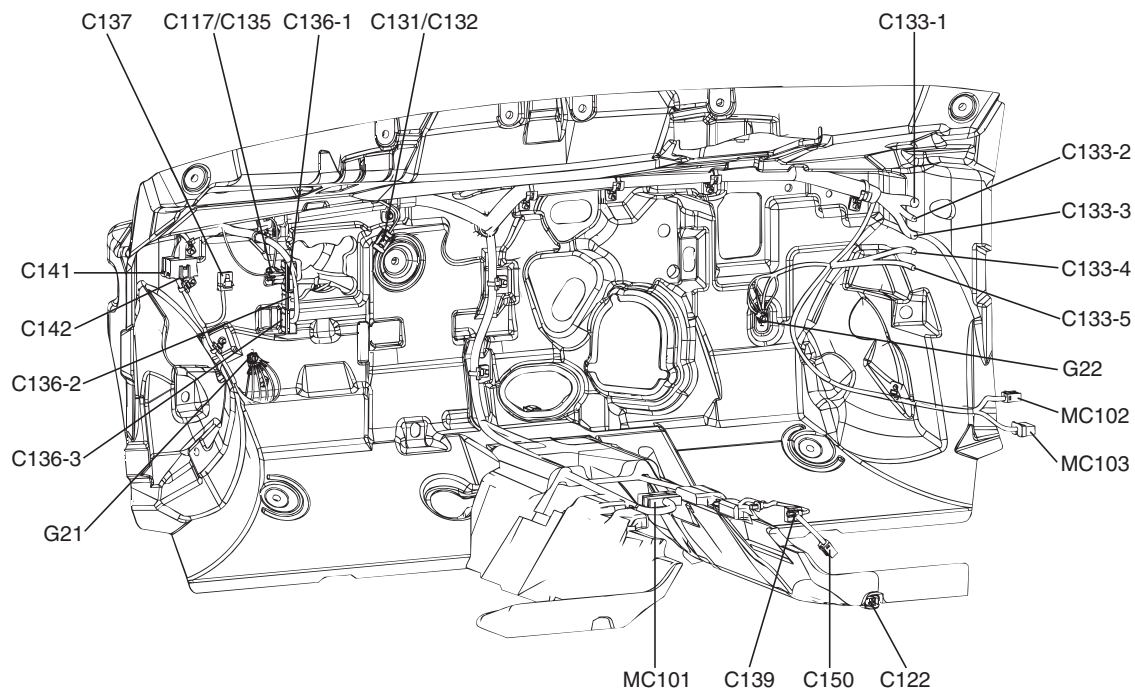

CONTROL HARNESS

CONTROL HARNESS (G6BA) (2)

HL-12

CONTROL HARNESS

C101 Transaxle range switch
C102-1 A/T pulse generator 'A'
C102-2 A/T pulse generator 'B'
C104 ATM solenoid valve
C105 Back-up lamp switch (5M/T)
C106 Back-up lamp switch (6M/T)
C107 Front wiper motor (LHD)
C108 Front wiper motor (RHD)
C109 Vehicle speed sensor (A/T & 6M/T)
C110 Vehicle speed sensor (5M/T)
C111 Engine coolant temperature sensor & sender
C112 Throttle position sensor
C113 Crankshaft position sensor
C114 Camshaft position sensor
C115 Oil pressure switch
C116 Front oxygen sensor
C117 Ignition lock switch
C118 Ignition coil
C120 Brake fluid level sensor
C121 Canister purge solenoid valve
C122 Rear oxygen sensor
C123-1 Knock sensor #1
C123-2 Knock sensor #2
C124-2 Injector #2
C124-4 Injector #4
C124-6 Injector #6
C125 Mass air flow sensor
C126 Idle speed control actuator
C127 Intake air temperature sensor
C128 A/C compressor
C129 Hood switch
C131 Stop lamp switch (W/O ESP & cruise)
C132 Stop lamp switch (With ESP & cruise)

INJECTOR HARNESS

C133-1 ECM
C133-2 ECM
C133-3 ECM
C133-4 ECM
C133-5 ECM
C135 Cruise clutch pedal position switch (M/T)
C136-1 TCM
C136-2 TCM
C136-3 TCM
C137 A/T control relay
C138 Cruise control module
C139 Sports mode switch
C141 Joint connector
C142 Joint connector
C144 Power steering switch
C145 Oxygen sensor (B1/S1)
C146 Oxygen sensor (B2/S1)
C147 Oxygen sensor (B1/S2)
C148 Oxygen sensor (B2/S2)
C150 G-YAW sensor (With ESP)
C151 Pressure sensor (With ESP)
CC101 Connection with INJECTOR harness
EC101 Connection with ENGINE harness
EC102 Connection with ENGINE harness
EC103 Connection with ENGINE harness
MC101 Connection with MAIN harness
MC102 Connection with MAIN harness
MC103 Connection with MAIN harness
G21 Ground (TCM)
G22 Ground (ECM)
G23 Ground (CONTROL)
G24 Ground (ENGINE)
C124-1 Injector #1
C124-3 Injector #3
C124-5 Injector #5
CC101 Connection with CONTROL harness

CONTROL HARNESS

CONTROL HARNESS (G4ED) (1)

HL-13

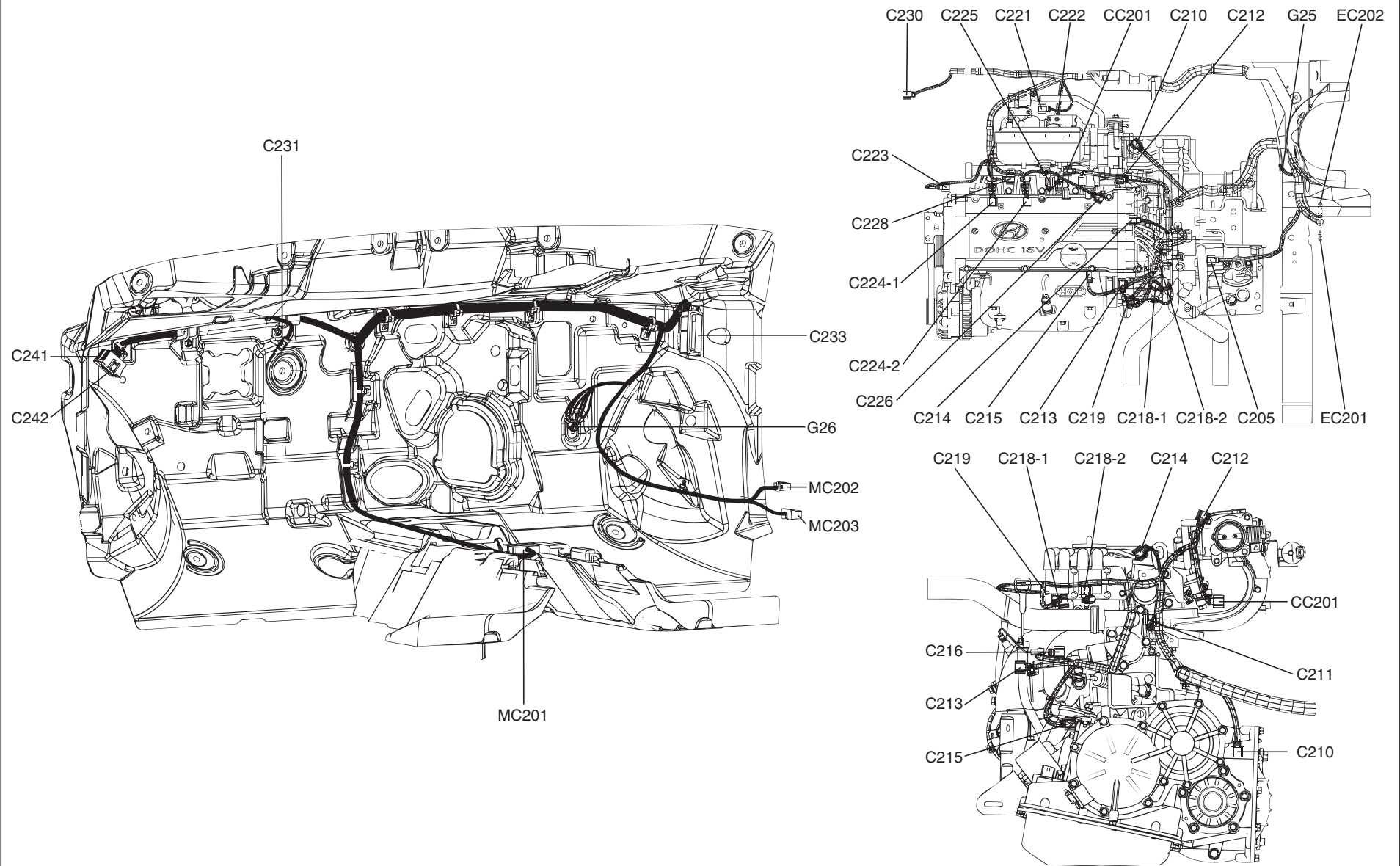

CONTROL HARNESS

CONTROL HARNESS (G4ED) (2)

HL-14

CONTROL HARNESS

C205 Back-up lamp switch
C207 Front wiper motor (LHD)
C208 Front wiper motor (RHD)
C210 Vehicle speed sensor
C211 Engine coolant temperature sensor & sender
C212 Throttle position sensor
C213 Crankshaft position sensor
C214 Camshaft position sensor
C215 Oil pressure switch
C216 Oxygen sensor (UP)
C218-1 Ignition coil #1
C218-2 Ignition coil #2
C219 Condenser
C220 Brake fluid level sensor
C221 Canister purge solenoid valve
C222 Oxygen sensor (DOWN)
C223 Knock sensor
C224-1 Injector #1
C224-2 Injector #2
C225 Manifold absolute pressure sensor

INJECTOR HARNESS

C226 Idle speed control actuator
C228 A/C compressor
C229 Hood switch
C230 Accelerator sensor
C231 Stop lamp switch
C233 ECM
C241 Joint connector
C242 Joint connector
CC201 Connection with INJECTOR harness
EC201 Connection with ENGINE harness
EC202 Connection with ENGINE harness
MC201 Connection with MAIN harness
MC202 Connection with MAIN harness
MC203 Connection with MAIN harness
G25 Ground (CONTROL)
G26 Ground (ECM)

C224-3 Injector #3
C224-4 Injector #4
CC201 Connection with CONTROL harness

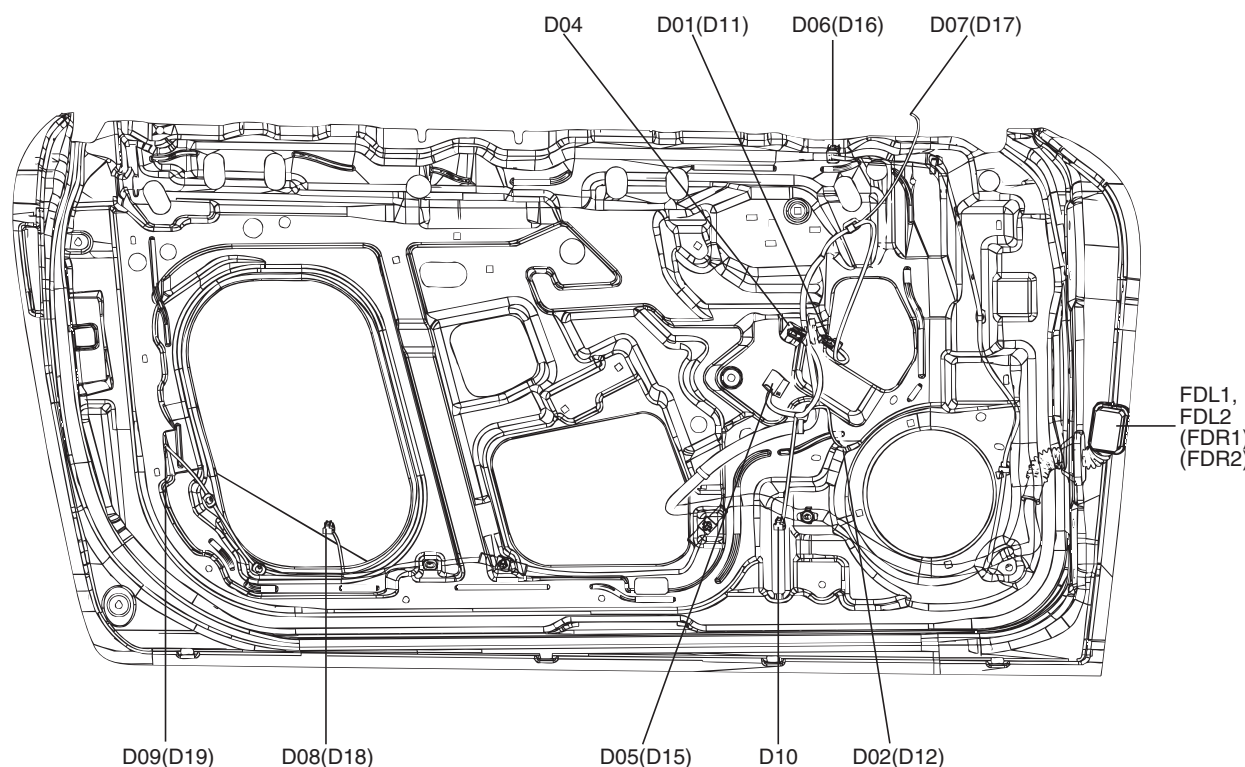

LEFT DOOR HARNESS

- D01 Left power window motor
- D02 Left front speaker
- D04 Outside mirror switch
- D05 Left power window switch
- D06 Left outside mirror & mirror folding motor
- D07 Left tweeter speaker
- D08 Left door lamp
- D09 Left door lock actuator (LHD)
- D09-1 Left door lock actuator (RHD)
- D10 Tail gate lid switch
- FDL1 Connection with FLOOR harness
- FDL2 Connection with FLOOR harness

RIGHT DOOR HARNESS

- D11 Right power window motor
- D12 Right front speaker
- D15 Right power window switch
- D16 Right outside mirror & mirror folding motor
- D17 Right tweeter speaker
- D18 Right door lamp
- D19 Right door lock actuator (LHD)
- D19-1 Right door lock actuator (RHD)
- FDR1 Connection with FLOOR harness
- FDR2 Connection with FLOOR harness

(): Right

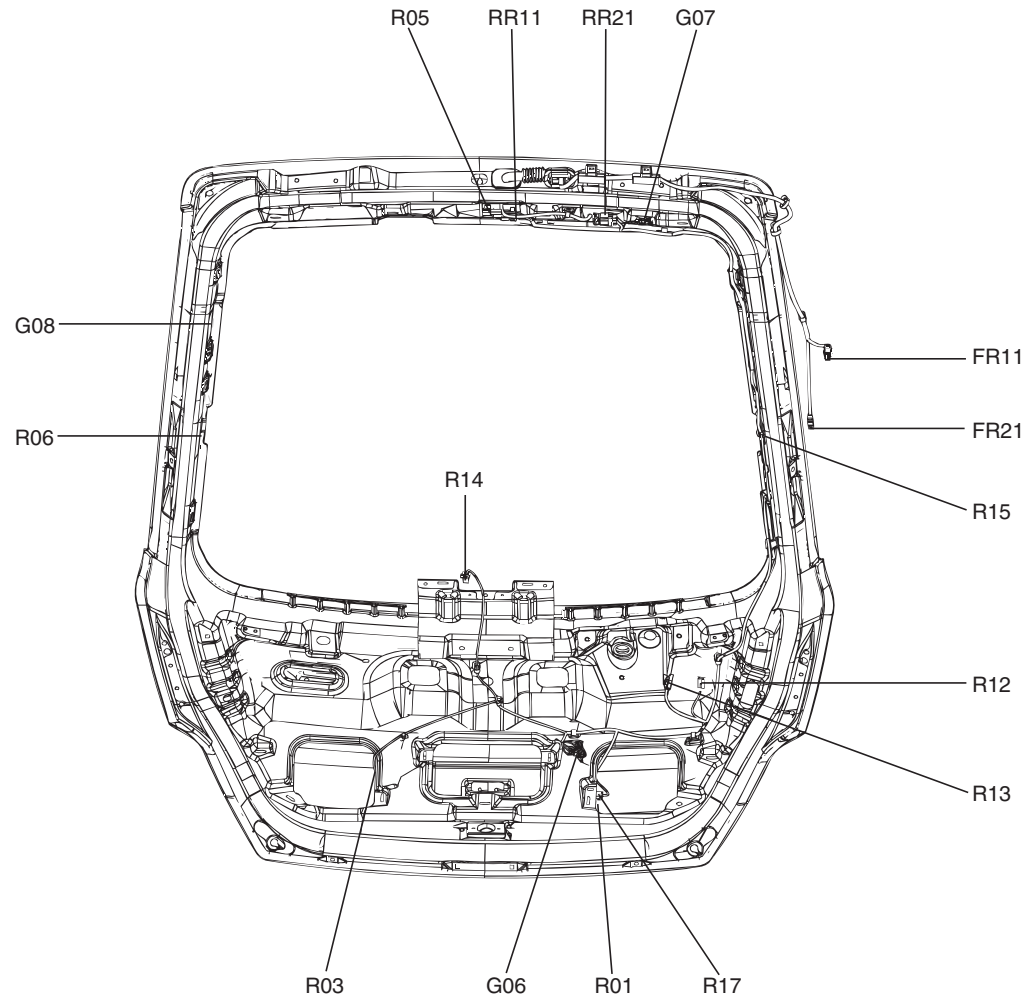

TAIL GATE HARNESS

- R01 Tail gate lid solenoid
- R03 Tail gate unlock switch
- R05 Glass antenna
- R06 Rear window defogger (-)
- R12 High-mounted stop lamp (Spoiler)
- R13 Rear wiper motor
- R14 High-mounted stop lamp (P/Tray)
- R15 Rear window defogger (+)
- R17 Luggage room lamp switch
- RR11 Connection with TAIL GATE EXT. harness
- RR21 Connection with TAIL GATE EXT. harness
- G06 Ground
- G07 Ground
- G08 Ground

TAIL GATE EXT. HARNESS

- FR11 Connection with FLOOR harness
- FR21 Connection with FLOOR harness
- RR11 Connection with TAIL GATE harness
- RR21 Connection with TAIL GATE harness

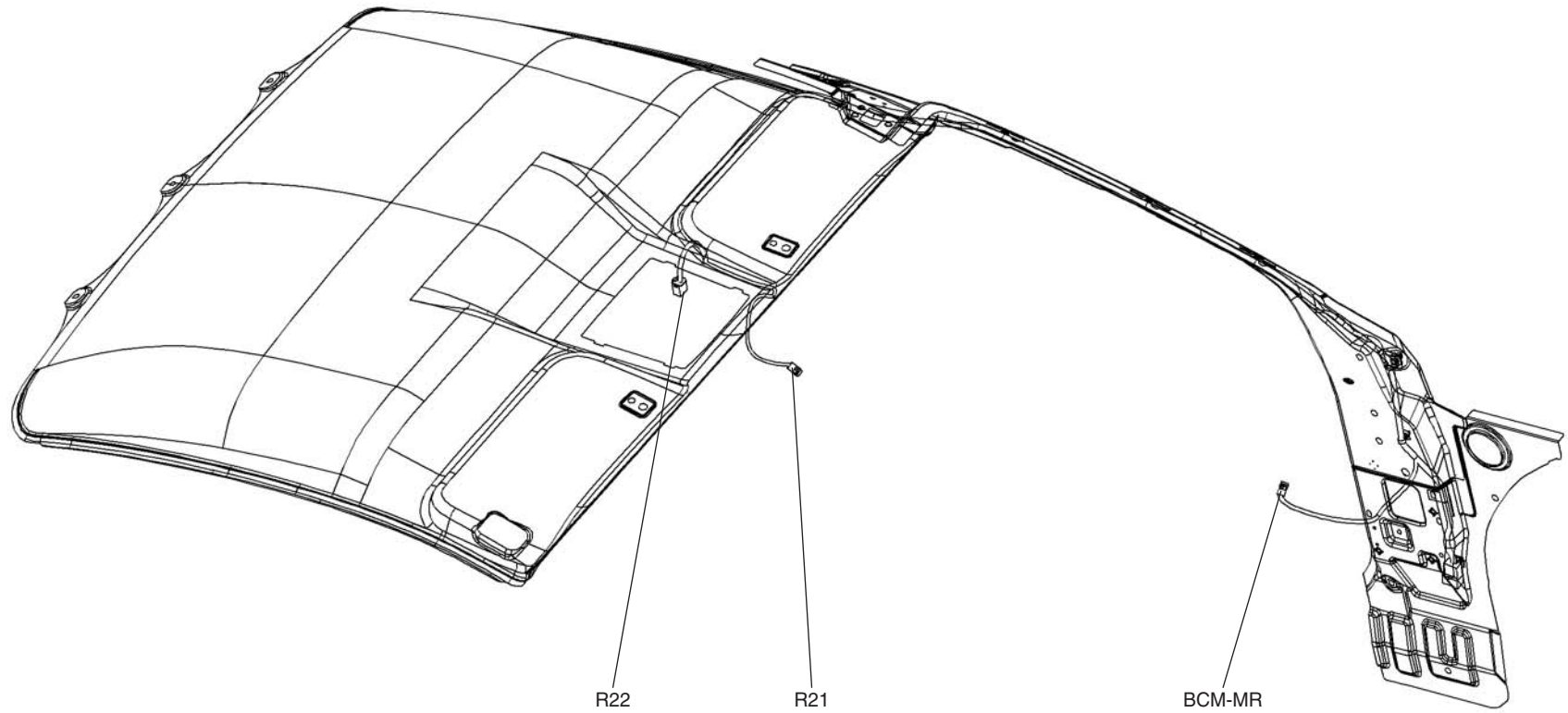

ROOF HARNESS

- R21 Electro chromic mirror
- R22 Overhead console lamp & sunroof switch
- R23 Sunroof
- R24 Sunroof controller
- R25 Sunroof motor
- BCM-MR Connection with BCM MODULE harness (LHD)
- MR11 Connection with MAIN harness (RHD)