

# MFI Control System (G8BA-GSL 4.6L) (1)

SD313-19

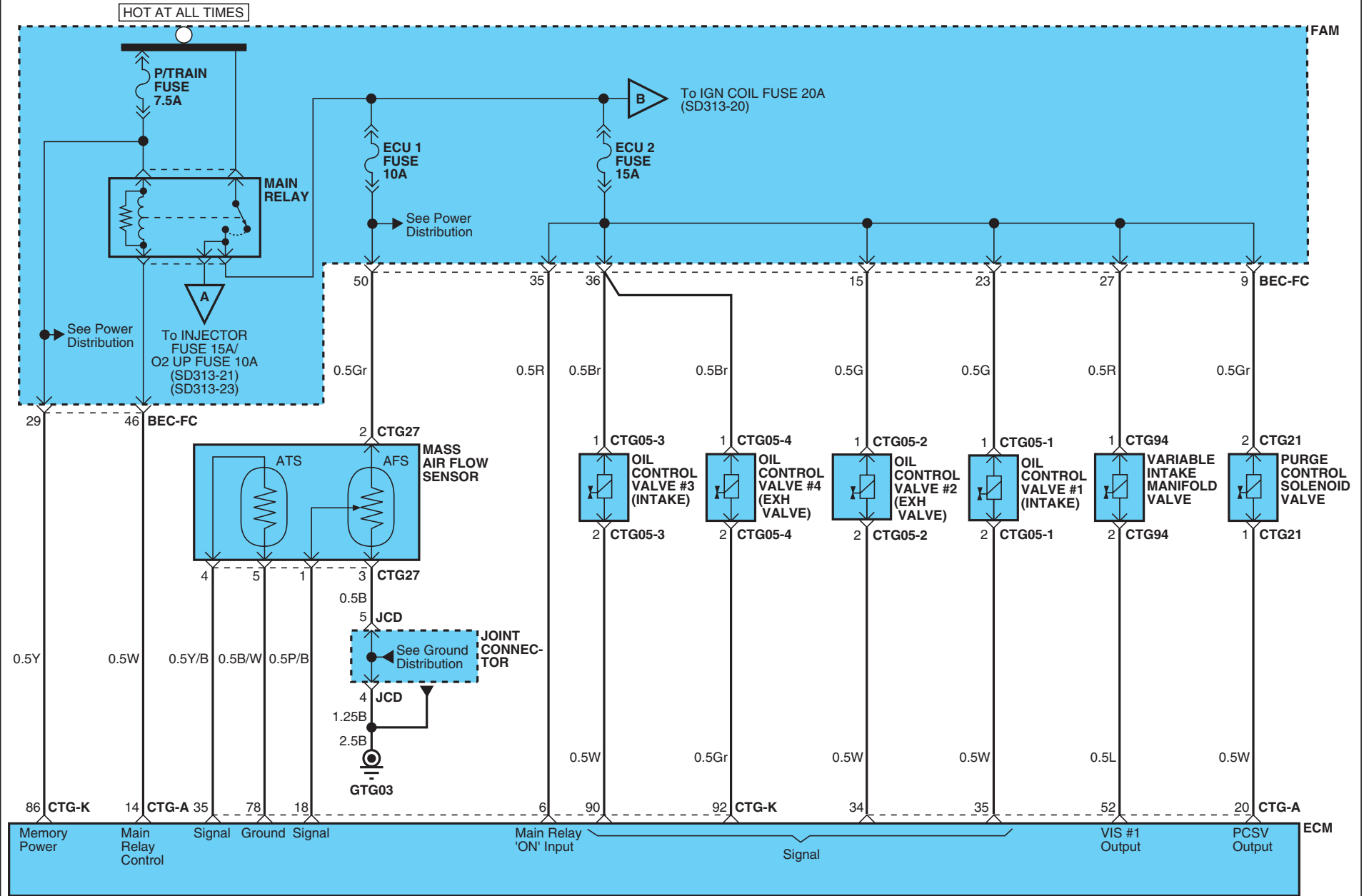

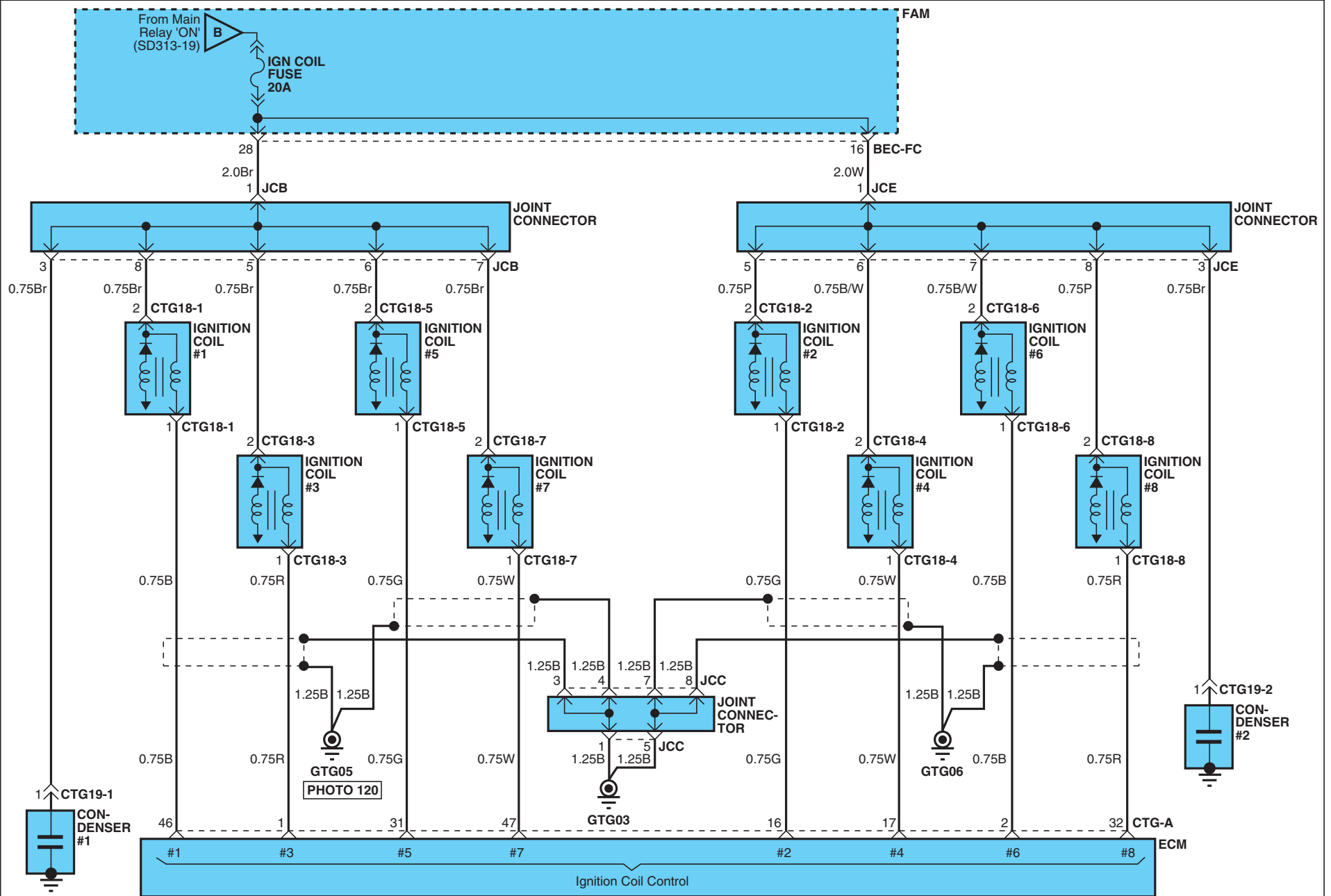

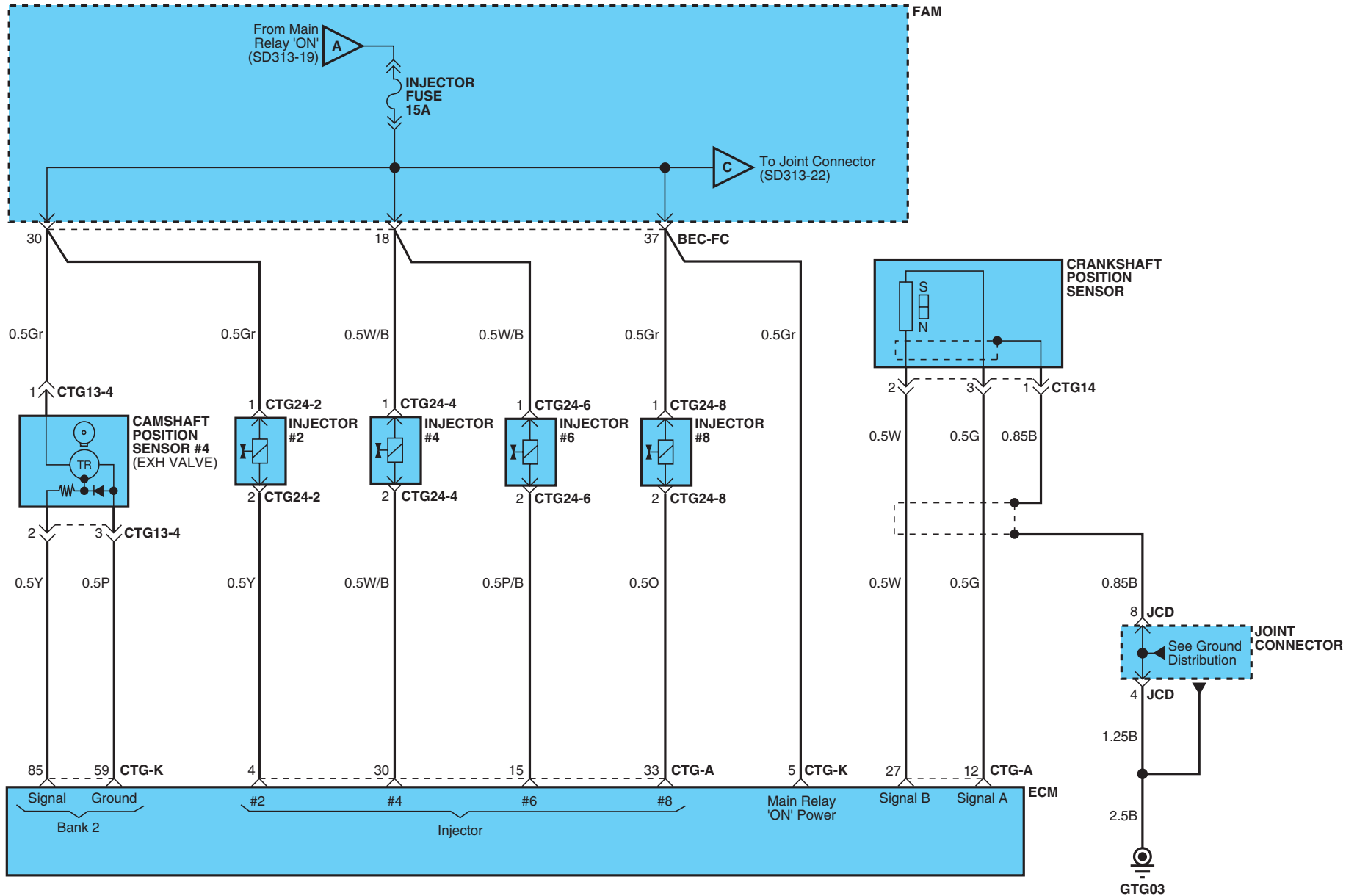

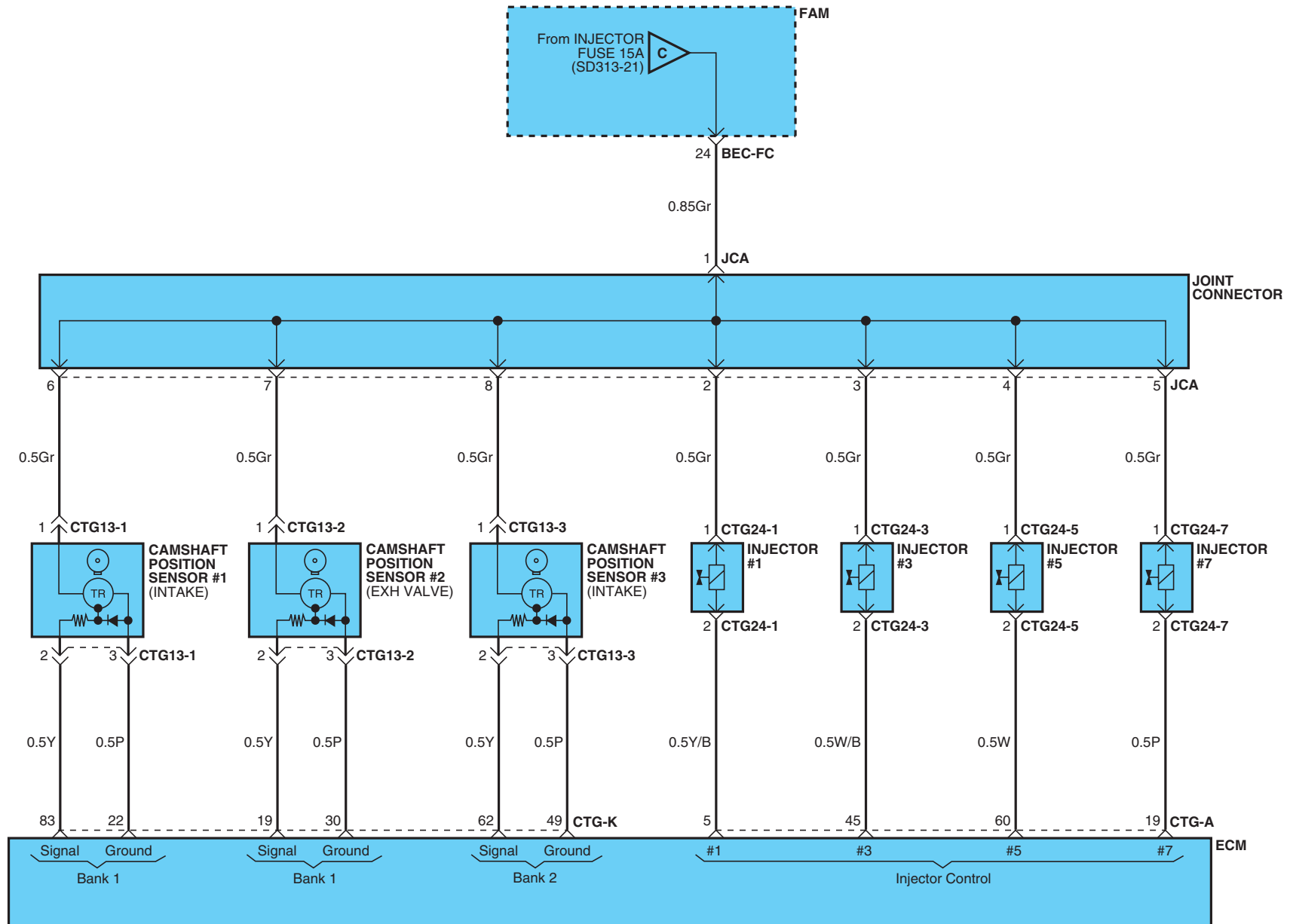

HOT AT ALL TIMES

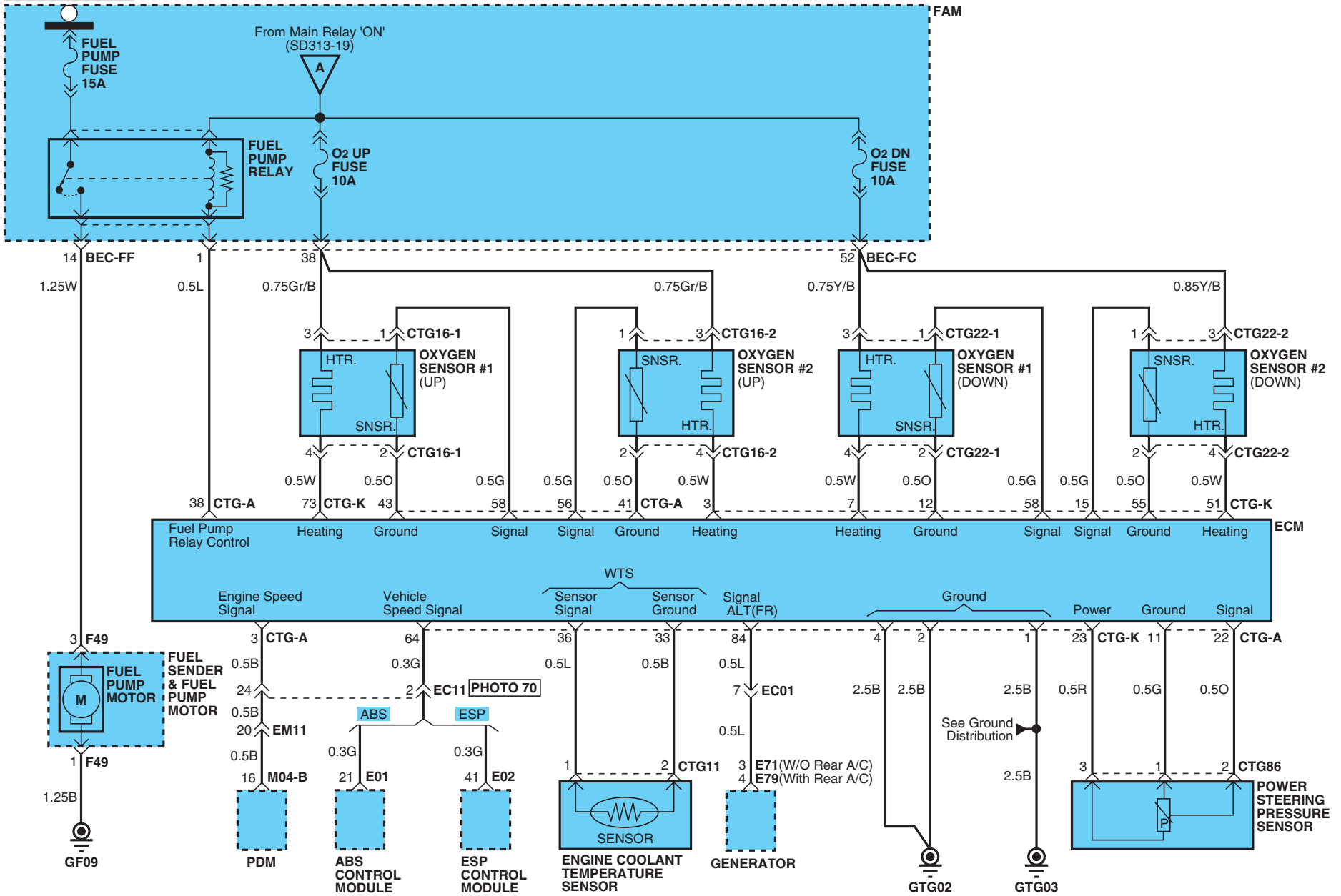

# MFI Control System (G8BA-GSL 4.6L) (6)

SD313-24

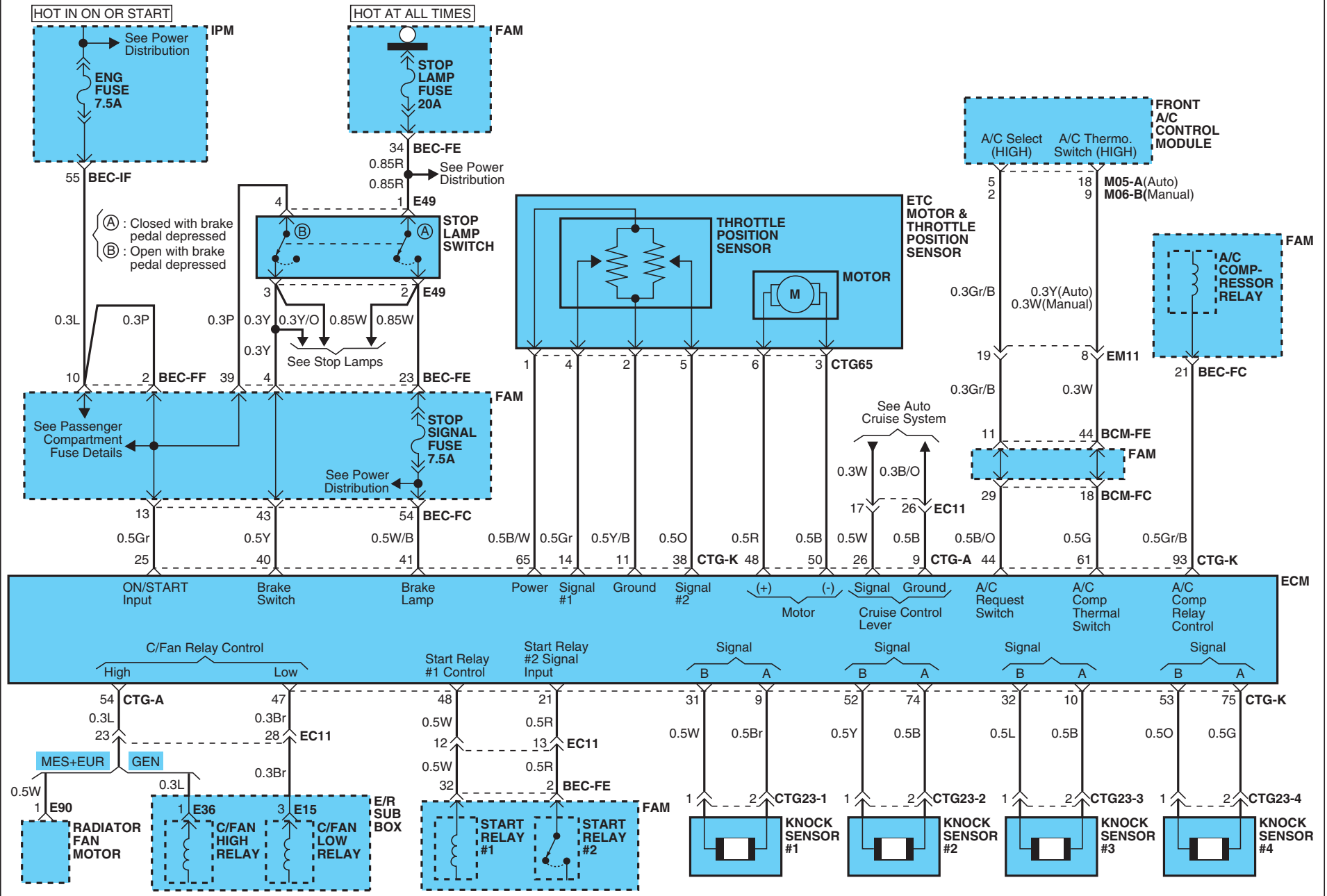

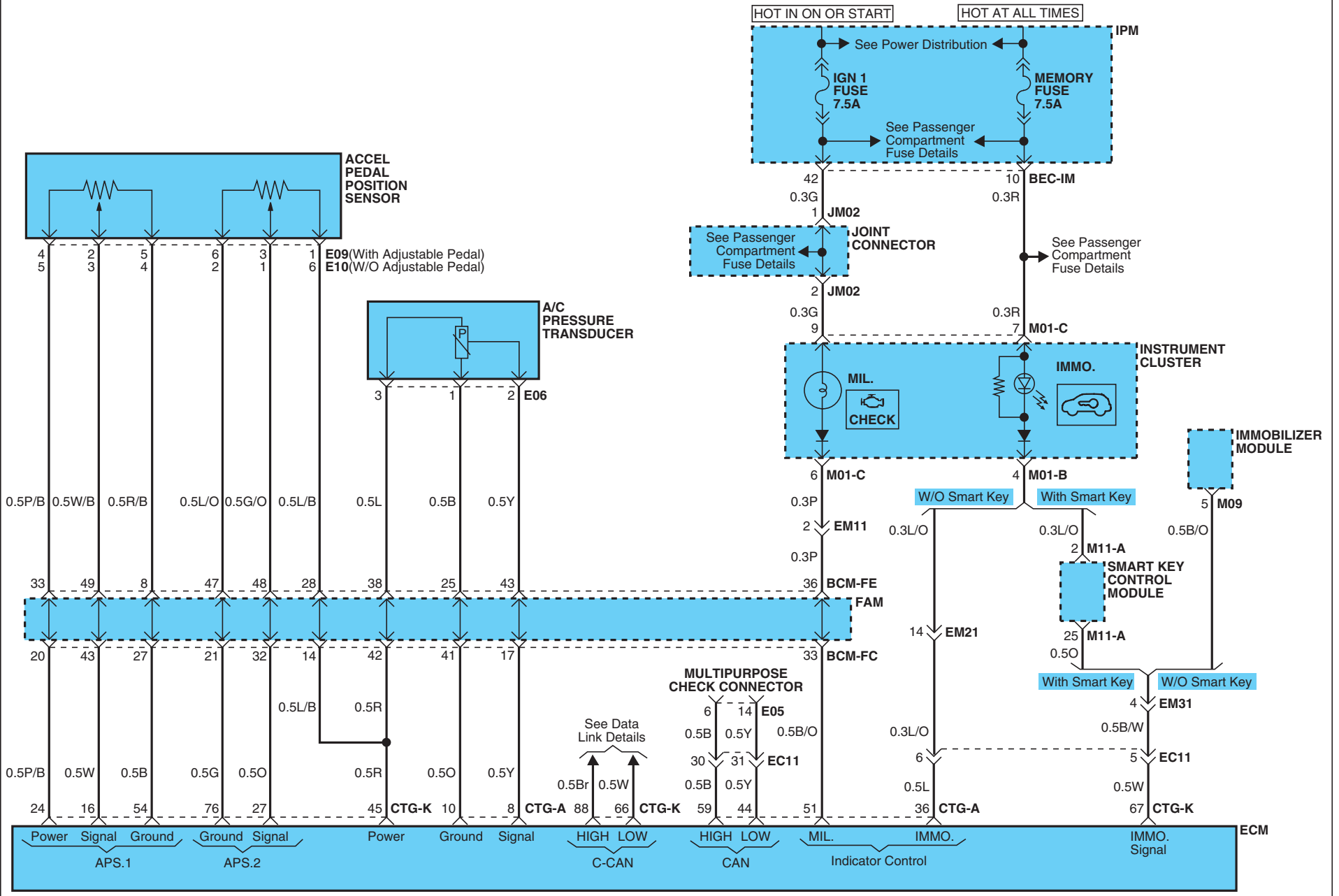

CTG-A

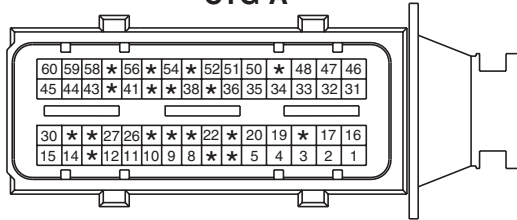

AMP\_ECU\_60F\_B

CTG-K

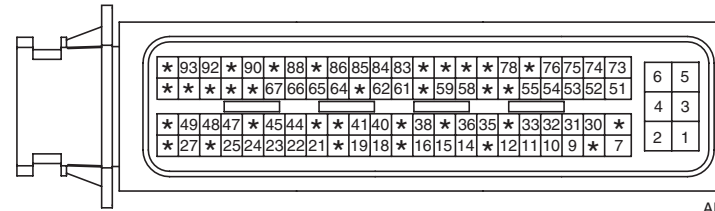

AMP\_ECU\_94F\_B

CTG05-1,3



KET\_090WP\_02F\_GR

CTG05-2,4



KET\_090WP\_02F\_B

CTG11

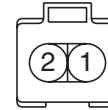

AMP\_090WP\_02F\_B

CTG13-1,2,3,4

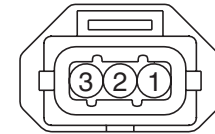

AMP\_JPT\_03F\_B\_BSH3

CTG14

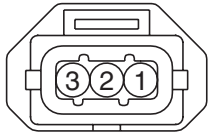

AMP\_JPT\_03F\_B\_BSH3

CTG16-1,2



KUM\_NMWP\_04F\_B

CTG18-1



KET\_090WP\_02F\_B\_L3

CTG18-2



KET\_090WP\_02F\_B\_L3

CTG18-3



KET\_090WP\_02F\_GR

CTG18-4



KET\_090WP\_02F\_GR

CTG18-5



KET\_090WP\_02F\_B\_L3

CTG18-6



KET\_090WP\_02F\_B\_L3

CTG18-7



KET\_090WP\_02F\_GR

CTG18-8



KET\_090WP\_02F\_GR

CTG19-1,2

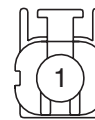

KET\_58X\_01F\_B

CTG21



AMP\_2.8WP\_02F\_B



CTG22-1/2



KUM\_NMWP\_04F\_B

CTG23-1/2



AMP\_JPT\_02F\_GR\_BSH2

CTG23-3/4



AMP\_2.8WP\_02F\_B

CTG24-1/2

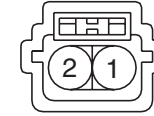

KUM\_NDWP\_02F\_Gr

CTG24-3



KUM\_NDWP\_02F\_B

CTG24-4

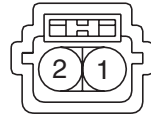

KUM\_NDWP\_02F\_B

CTG24-5

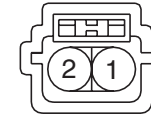

KUM\_NDWP\_02F\_Gr

CTG24-6

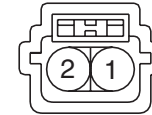

KUM\_NDWP\_02F\_Gr

CTG24-7



KUM\_NDWP\_02F\_B

CTG24-8



KUM\_NDWP\_02F\_B

CTG27

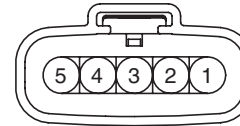

PKD\_GT150\_05F\_B

CTG65

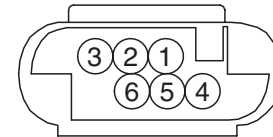

AMP\_MQSWP\_06F\_B\_1

CTG86

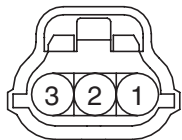

KET\_040WP\_03F\_B

CTG94

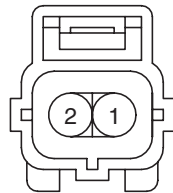

AMP\_EJWP\_02F\_B

E01

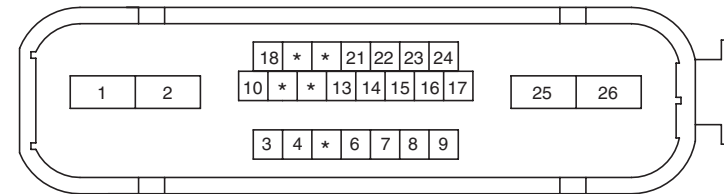

FCL\_ABS\_26F\_B

E02

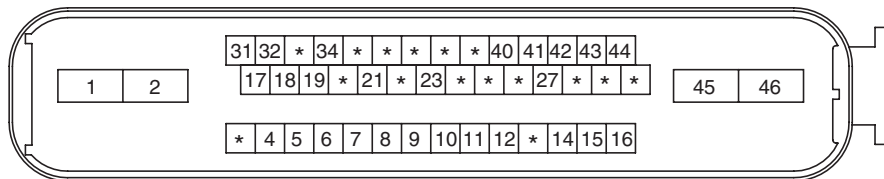

FCL\_ESP\_46F\_B\_1

E05

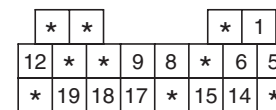

KET\_DIAG\_20F\_B\_BRK\_GH

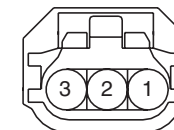

E06



KET\_040WP\_03F\_B

**MFI Control System (G8BA-GSL 4.6L) (10)**

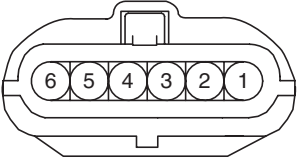
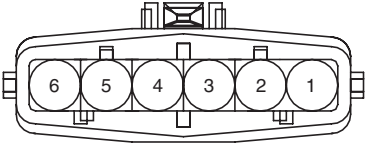
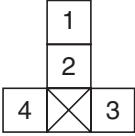
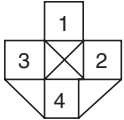
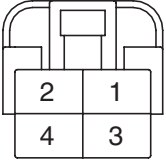
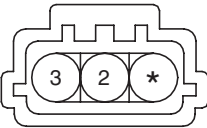
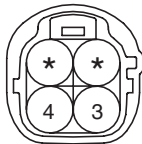
**SD313-28**

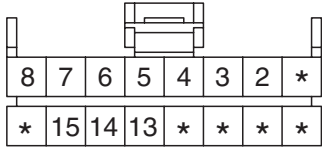
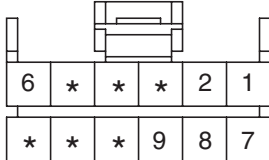
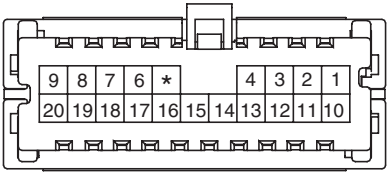
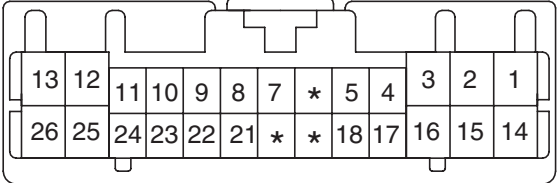
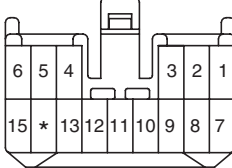
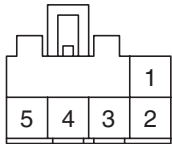
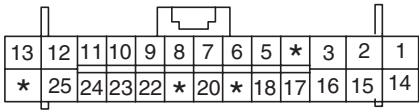
<p><b>E09</b></p>  <p>AMP_070WP_06F_B</p>	<p><b>E10</b></p>  <p>AMP_JPT_06F_B</p>	<p><b>E15</b></p>  <p>CR04F094</p>	<p><b>E36</b></p>  <p>CR04F063</p>
<p><b>E49</b></p>  <p>KET_250DL_04F_W</p>	<p><b>E71</b></p>  <p>KET_ALTWP_03F_GR</p>	<p><b>E79</b></p>  <p>SUM_TSWP_04F_B</p>	<p><b>E90</b></p>  <p>YAZ_1595WP_04F_B</p>
<p><b>F49</b></p>  <p>KET_090IWP_05F_Gr_2</p>	<p><b>M01-B</b></p>  <p>AMP_040M1_16F_B</p>	<p><b>M01-C</b></p>  <p>AMP_040M1_12F_B</p>	<p><b>M04-B</b></p>  <p>KET_040III_20F_W</p>
<p><b>M05-A</b></p>  <p>KET_0407_26F_W</p>		<p><b>M06-B</b></p>  <p>KET_050_15F_W</p>	<p><b>M09</b></p>  <p>KUM_CDR_05F_W</p>
<p><b>M11-A</b></p>  <p>AMP_0407_26F_W_HD</p>	<p><b>BLANK</b></p>	<p><b>BLANK</b></p>	<p><b>BLANK</b></p>

# Automatic Transmission Control System (G8BA-GSL 4.6L) (1)

SD450-7

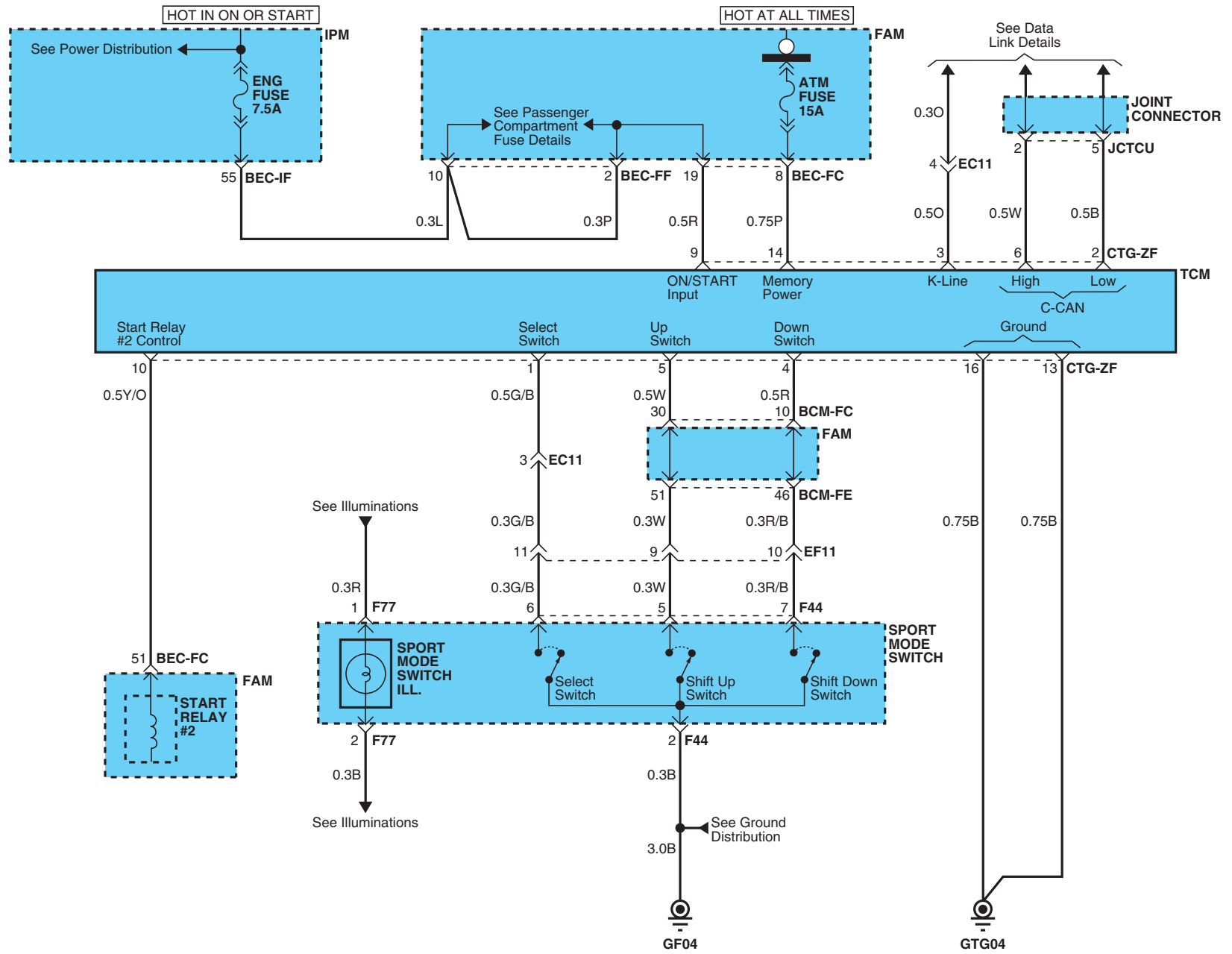

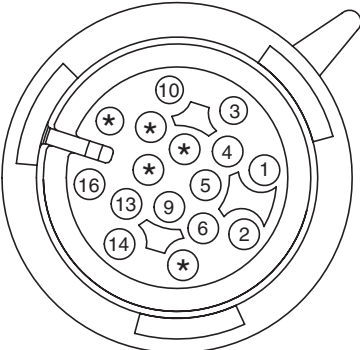
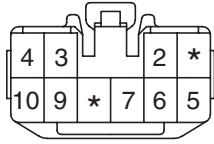
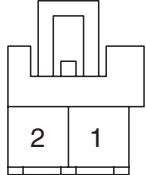
<p style="text-align: center;"><b>CTG-ZF</b></p>  <p style="text-align: right; font-size: small;">KSTL_TCU_16F_B</p>	<p style="text-align: center;"><b>F44</b></p>  <p style="text-align: right; font-size: small;">KET_090II_10F_W</p>	<p style="text-align: center;"><b>F77</b></p>  <p style="text-align: right; font-size: small;">KUM_CDR_02F_W</p>	<p style="text-align: center;"><b>BLANK</b></p>
	<p style="text-align: center;"><b>BLANK</b></p>	<p style="text-align: center;"><b>BLANK</b></p>	<p style="text-align: center;"><b>BLANK</b></p>

Front Blower & A/C Control System (Auto) (1)

SD971-1

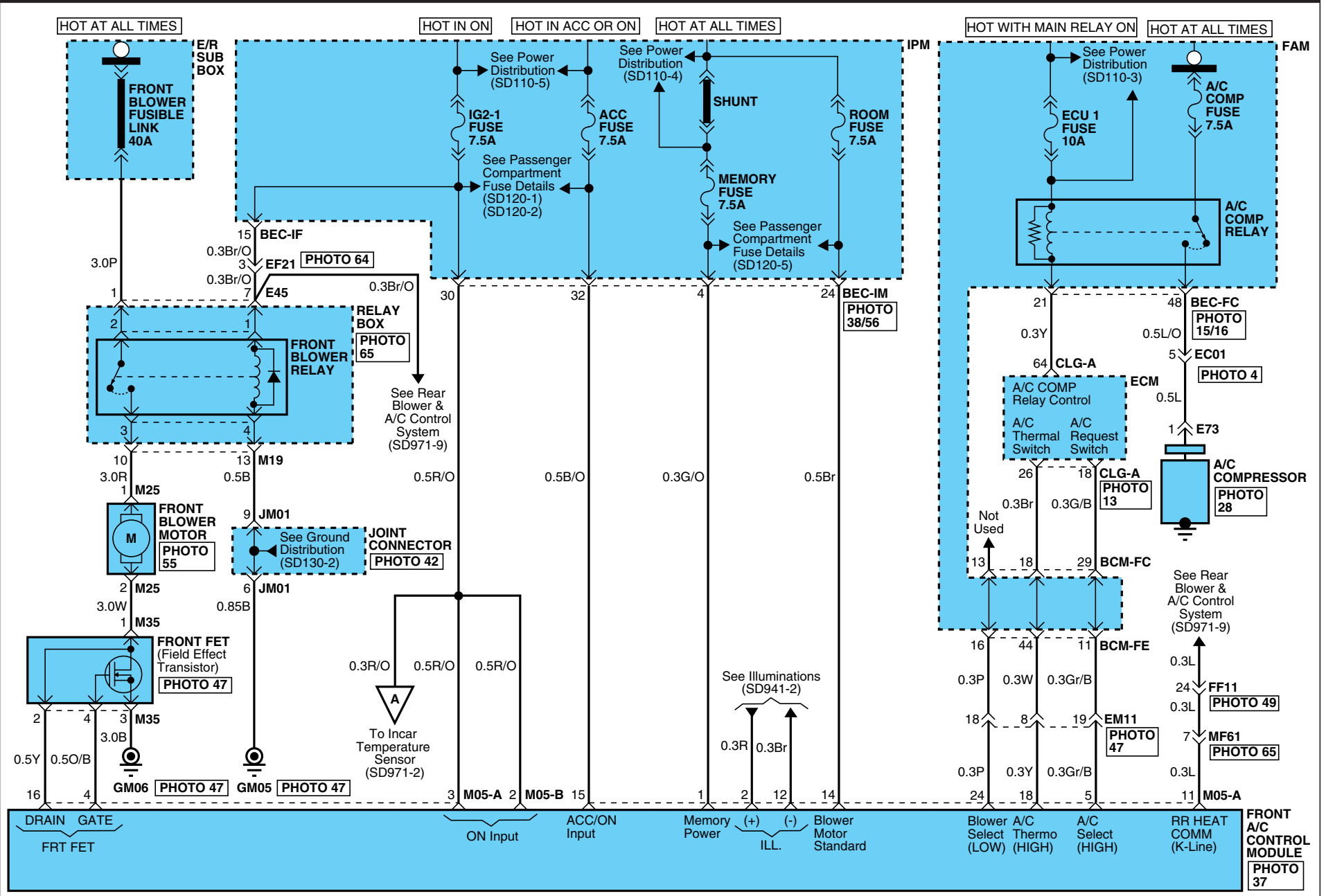

# FRONT BLOWER & A/C CONTROL SYSTEM

## Front Blower & A/C Control System (Auto) (2)

SD971-2

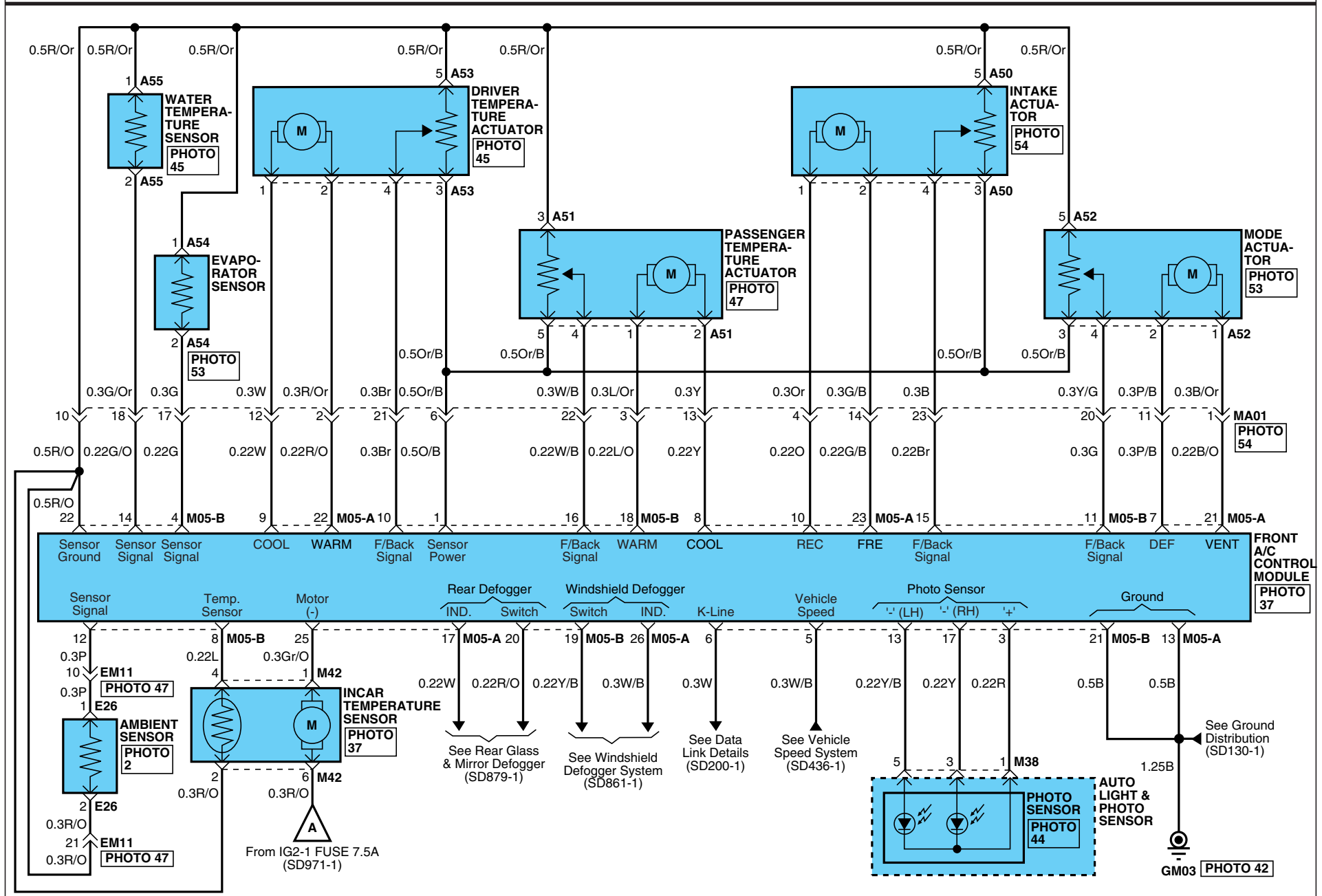

# FRONT BLOWER & A/C CONTROL SYSTEM

## Front Blower & A/C Control System (Auto) (3)

SD971-3

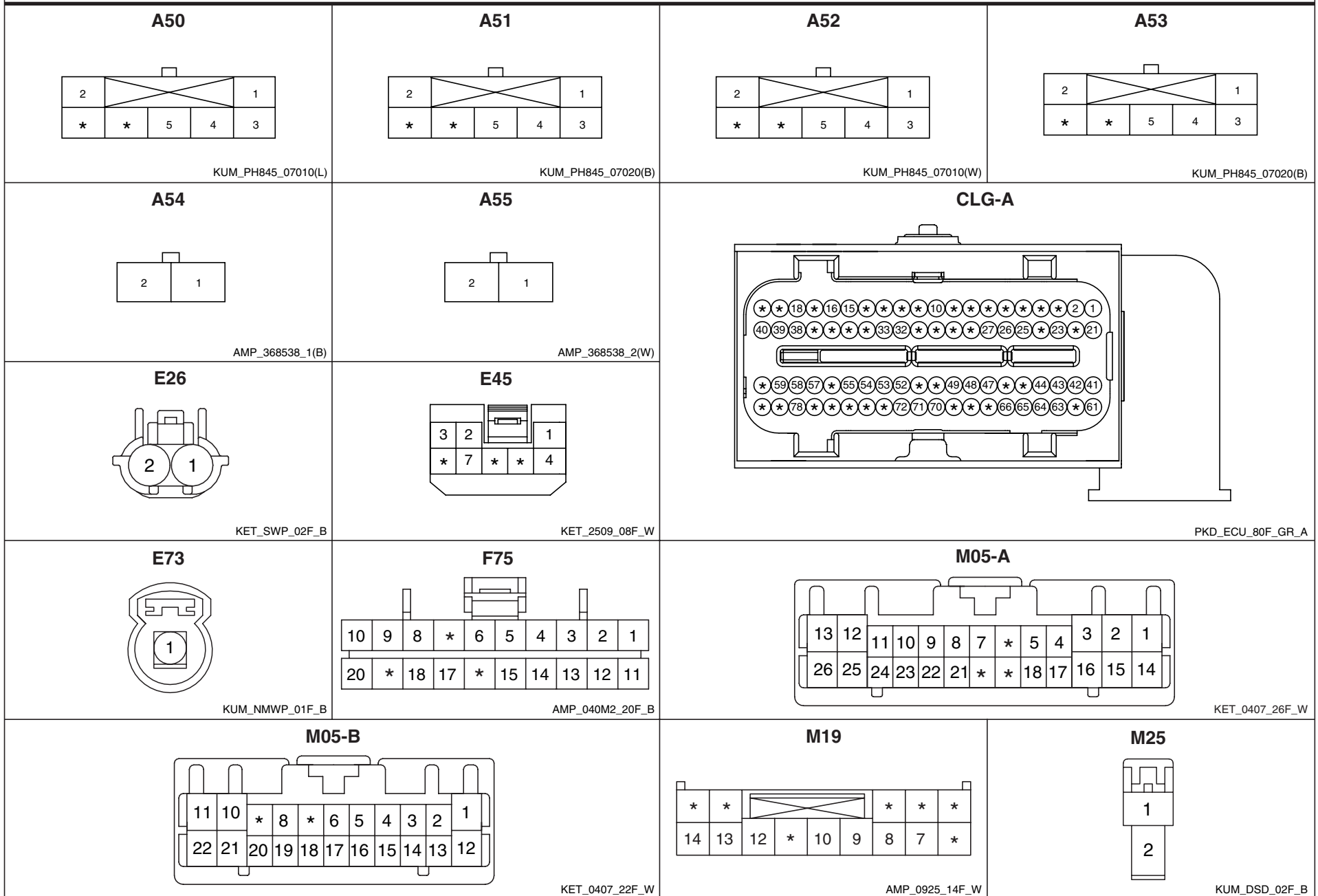

# FRONT BLOWER & A/C CONTROL SYSTEM

## Front Blower & A/C Control System (Auto) (4)

SD971-4

M35

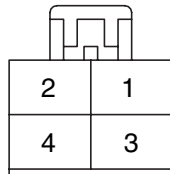

KUM\_DSD\_04F\_W

M38

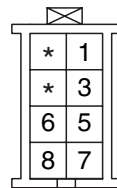

KET\_030\_08F\_W

M42

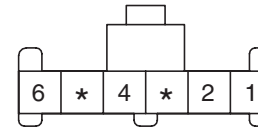

KET\_91A\_06F\_W

BLANK



Front Blower & A/C Control System (Manual) (1)

SD971-5

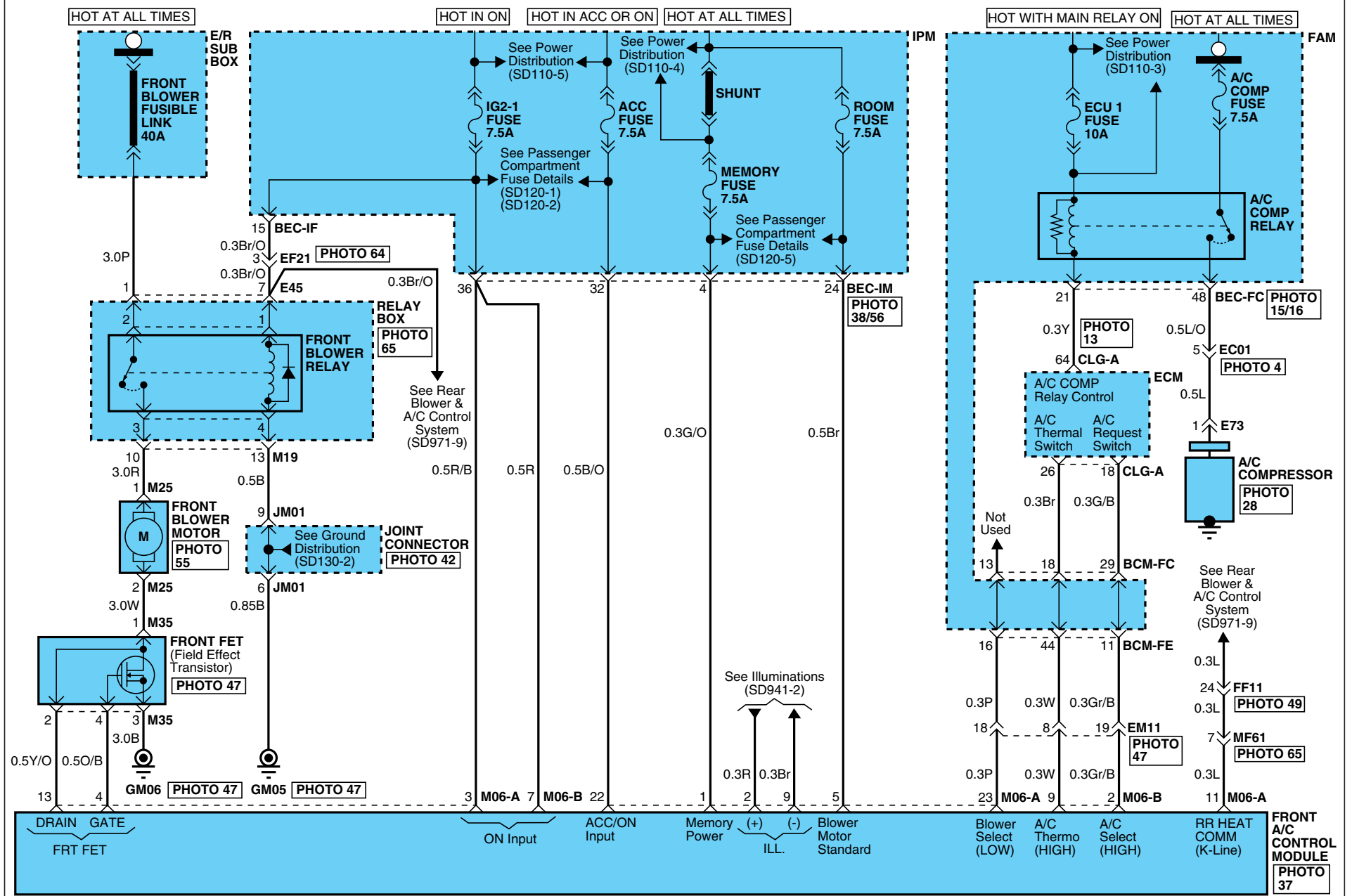

# FRONT BLOWER & A/C CONTROL SYSTEM

## Front Blower & A/C Control System (Manual) (2)

SD971-6

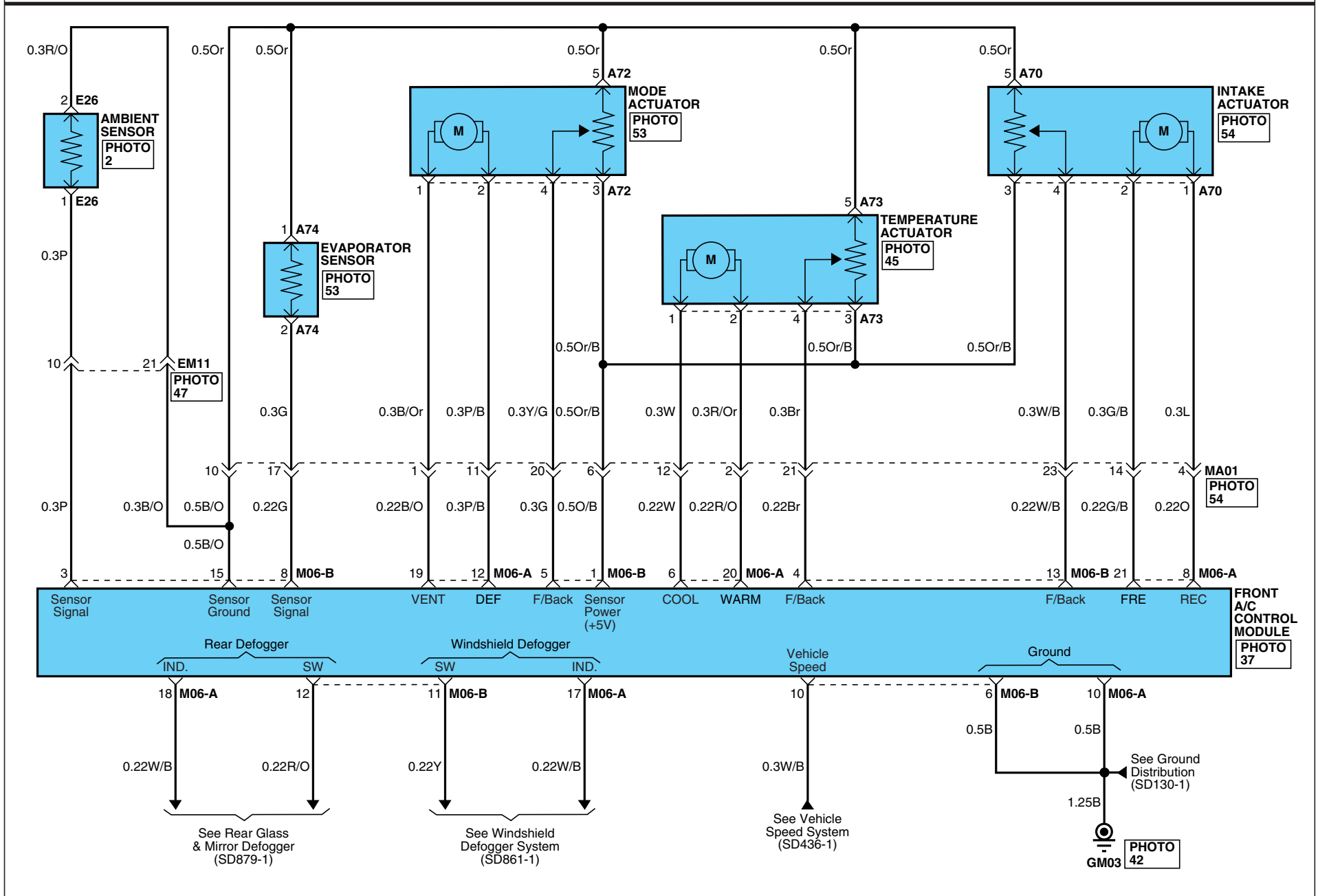

# FRONT BLOWER & A/C CONTROL SYSTEM

## Front Blower & A/C Control System (Manual) (3)

SD971-7

**A70**

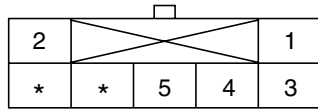

KUM\_PH845\_07010(L)

**A72**

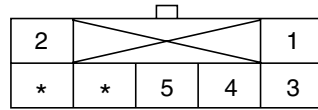

KUM\_PH845\_07010(W)

**A73**

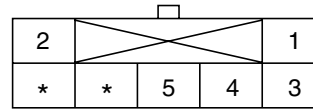

KUM\_PH845\_07020(B)

**A74**

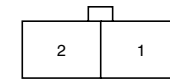

AMP\_368538\_1(B)

**CLG-A**

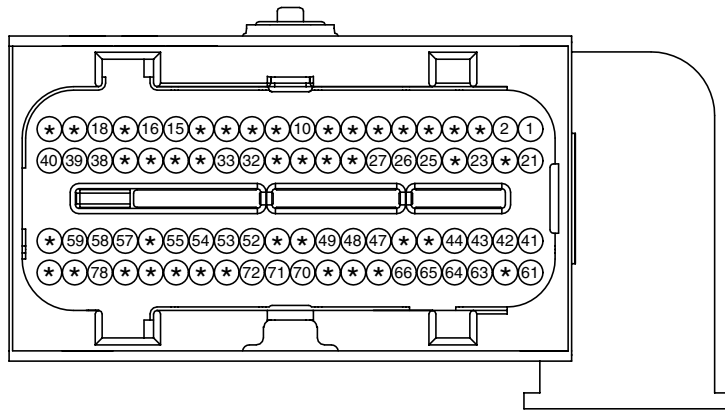

PKD\_ECU\_80F\_GR\_A

**E26**

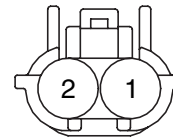

KET\_SWP\_02F\_B

**E45**

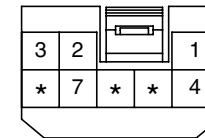

KET\_2509\_08F\_W

**E73**



KUM\_NMWP\_01F\_B

**F75**

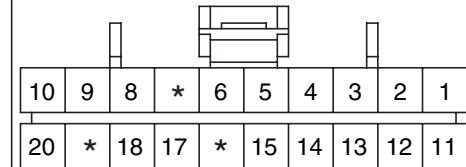

AMP\_040M2\_20F\_B

**M06-A**

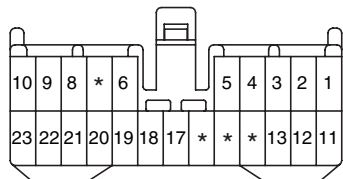

KET\_050\_23F\_W

**M06-B**

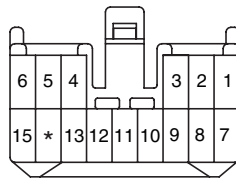

KET\_050\_15F\_W

**M19**

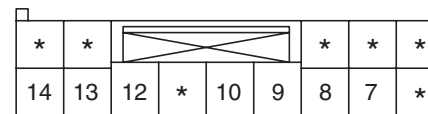

AMP\_0925\_14F\_W

**M25**

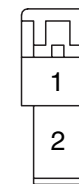

KUM\_DSD\_02F\_B

**M35**

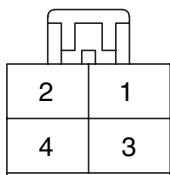

KUM\_DSD\_04F\_W

**BLANK**

**BLANK**

**BLANK**

**FRONT BLOWER & A/C CONTROL SYSTEM**

Front Blower & A/C Control System (Manual) (4)

**SD971-8**

**MEMO**

Rear Blower & A/C Control System (1)

SD971-9

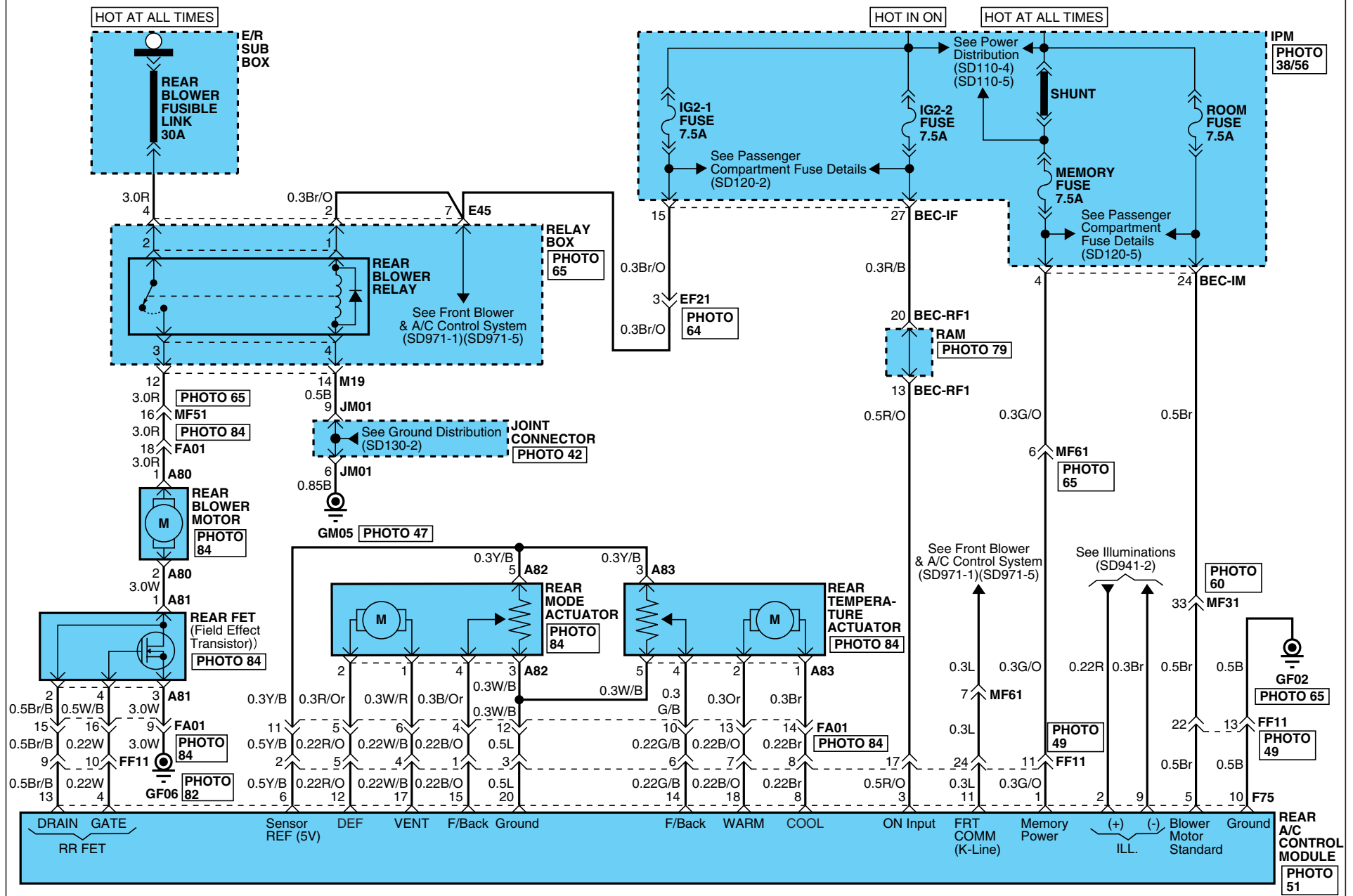

# REAR BLOWER & A/C CONTROL SYSTEM

## Rear Blower & A/C Control System (2)

SD971-10

**A80**

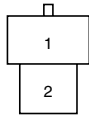

KUM\_PH776\_02025

**A81**

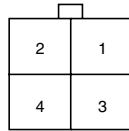

KUM\_PH776\_04027

**A82**

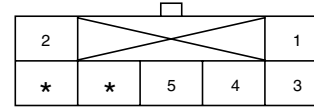

KUM\_PH845\_07010(W)

**A83**

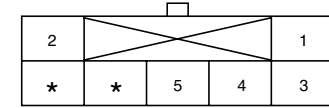

KUM\_PH845\_07020(B)

**E45**

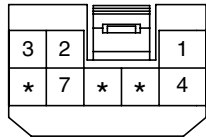

KET\_2509\_08F\_W

**F75**

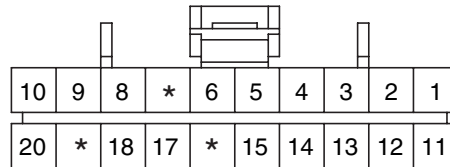

AMP\_040M2\_20F\_B

**M19**

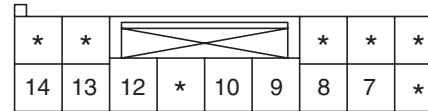

AMP\_0925\_14F\_W

**BLANK**