

INTRODUCTION (1)

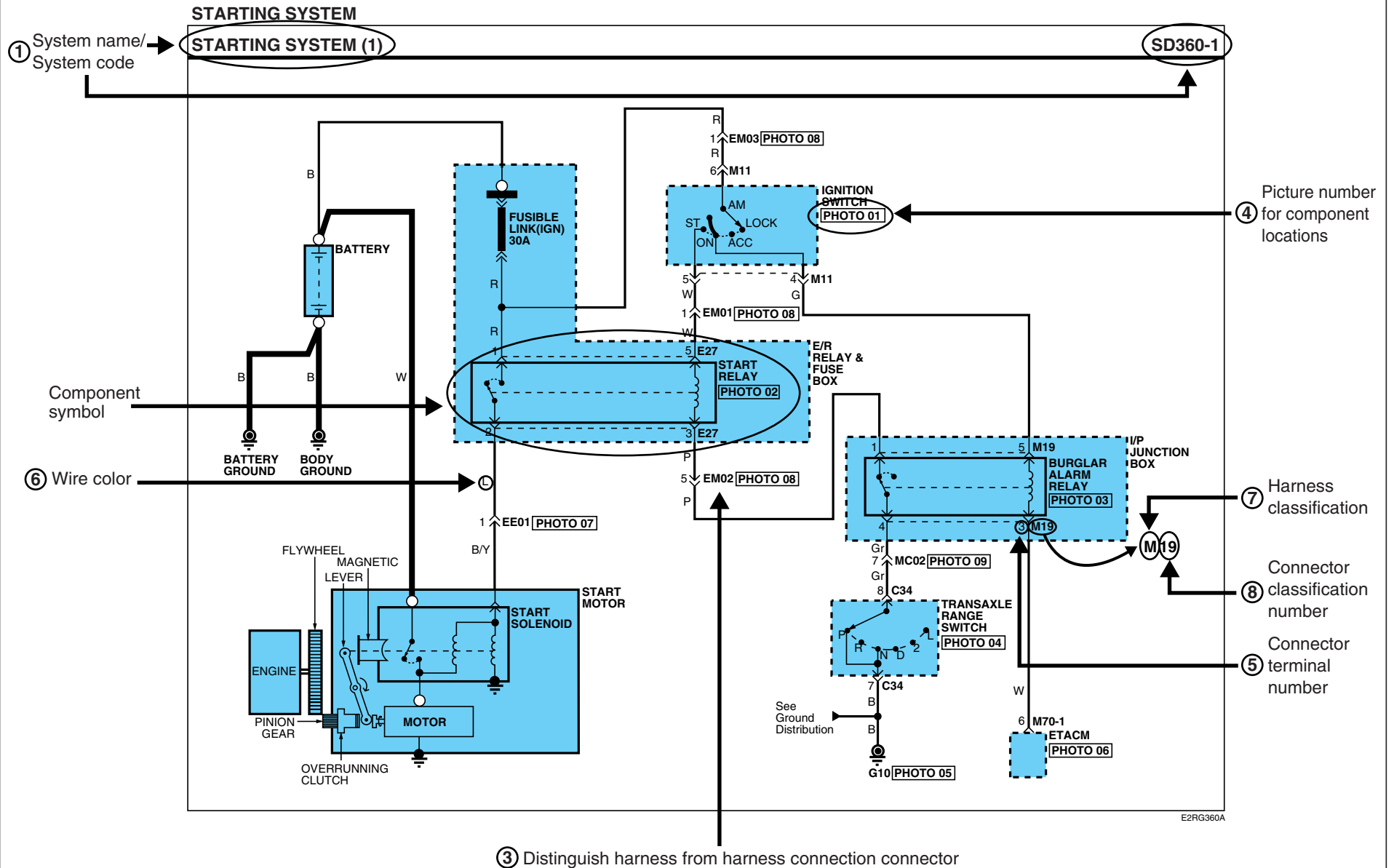

# INTRODUCTION

## INTRODUCTION (2)

GI-2

### STARTING SYSTEM

#### STARTING SYSTEM (2)

SD360-2

② Connector configurations (components)

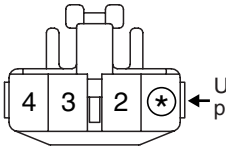
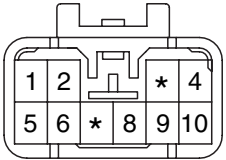
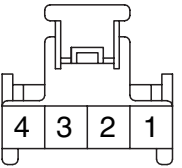
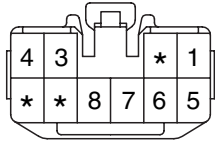
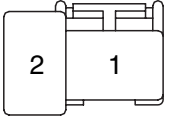
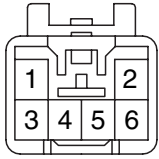
<p><b>M05</b></p>  <p>Unused pin</p> <p>KET_090II_04F_W</p>	<p><b>M06</b></p>  <p>KET_090II_10M_W</p>	<p><b>M11</b></p>  <p>KUM_AR_04F_W</p>	<p><b>M13</b></p>  <p>KET_090II_10F_W</p>
<p><b>M67</b></p>  <p>AMP_PLM2_02F_B</p>	<p><b>M81</b></p>  <p>KET_090II_06M_W</p>	<p><b>BLANK</b></p>	<p><b>BLANK</b></p>

E2RG360B

Explanation of connector code

### M05

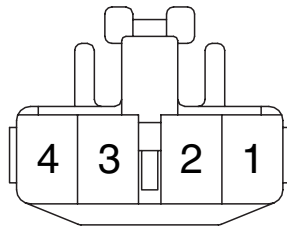

KET\_090II\_04F\_W

a b c d e

a : Connector manufacturer

b : Terminal series number

c : The number of connector terminals

d : Connector distinguishing

Female Pin : F

Male Pin : M

e : Connector color abbreviations

B (Black)

Br (Brown)

G (Green)

Gr (Gray)

L (Blue)

R (Red)

W (White)

Y (Yellow)

① Pages by system/ Name of Schematic diagram

- Each page is consisted of circuits by system. This schematic diagram includes the path of electricity flow, connection condition for each switch, and the function of other relevant circuits at once. It is applicable to real service work.
- It is very important to understand relevant circuits exactly before troubleshooting diagnosis.
- Circuits by system depends upon part number and are indicated on schematic diagram index.

② Connector configuration (components)

- The connector figure of components in the schematic diagram by system is indicated on the last page of schematic diagram.
- It shows the front of the connector on the harness side when not to the harness connector. The terminal number on each connector can be obtained by following the pattern used in ⑤ connector view and numbering order. Unused terminals are marked with an asterisk (\*).

③ Connector configurations (connection between harnesses)

- When connecting the harness with connector between harnesses, it shows female and male connectors and indicates them on the connector configurations group.

EM02

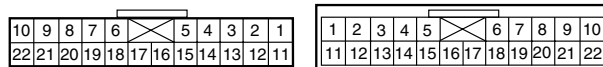

④ Component locations

- To find the components easily, a component locations diagram is indicated with "PHOTO NO" on the lower portion of the component name.
- To make it easy to distinguish connectors, the connector in the picture is indicated being installed in the vehicle.

PHOTO 03

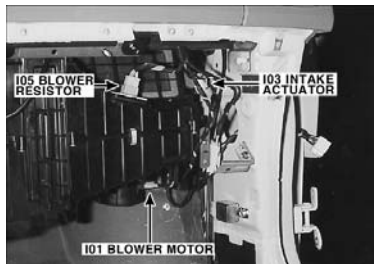

⑤ CONNECTOR VIEW AND NUMBERING ORDER

Female	Male	Remarks
		<p>It is not the shape of the connector housing, but the connector pin that distinguishes between male or female connectors. When numbering female and male connectors, refer to the numbering order in the following table. Some connectors may not follow this method of numbering order. For individual detailed numbering, refer to the CONNECTOR CONFIGURATIONS.</p>
		<p>Numbered in order from upper right to lower left</p> <p>Numbered in order from upper left to lower right</p>

NOTE

UNLESS OTHERWISE STATED, ALL CONNECTOR VIEWS ARE FROM THE TERMINAL SIDE OF THE CONNECTOR.

# INTRODUCTION

## INTRODUCTION (4)

GI-4

### ⑥ WIRE COLOR ABBREVIATIONS

The following abbreviations are used to identify wire colors in the circuit schematics.

Symbol	Color of wire	Symbol	Color of wire
B	Black	O	Orange
Br	Brown	P	Pink
G	Green	R	Red
Gr	Gray	W	White
L	Blue	Y	Yellow
Lg	Light Green	Pp	Purple
T	Tan	LI	Light Blue

\* (Y)/(B): Black stripe with yellow ground (2 colors)

↑                      ↑  
the color of        the color of  
background        stripe

### ⑦ HARNESS CLASSIFICATION

Electrical wiring connectors are classified according to the wiring parts in the Harness Layouts.

Symbol	Harness name	Location
C	Control, Injector, Ignition harness	Engine compartment, Passenger compartment
D	Door harness	Door
E	Engine, Battery harness	Engine compartment
F	Floor, Back warning harness	Floor, Trunk
M	Main, Roor, Sunroof, Air bag harness	Passenger compartment, Roof, Under crash pad and Floor
R	Trunk harness	Trunk
S	Seat harness	Seat

\* It depends on vehicles, it is necessary to check the harness name symbol on the harness layouts for detailed symbol.

### ⑧ CONNECTOR IDENTIFICATION

A connector identification symbol consists of a wiring harness location classification symbol corresponding to a wiring harness location and number corresponding to the connector. These connector locations can be found in the HARNESS LAYOUTS.

For example:

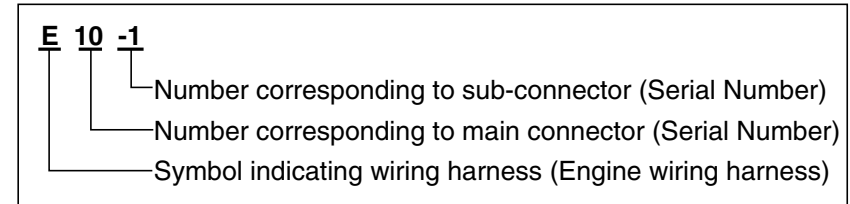

#### NOTE

Connectors which connect each wiring harness are represented by the following symbols.

For example:

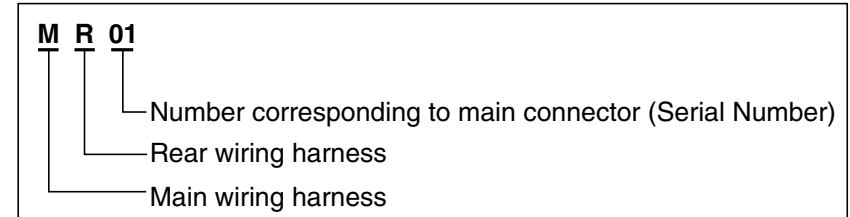

### JUNCTION BLOCK IDENTIFICATION

A junction block identification symbol consists of a wiring harness location classification symbol corresponding to a wiring harness location and number corresponding to the connector in the junction block.

For example:

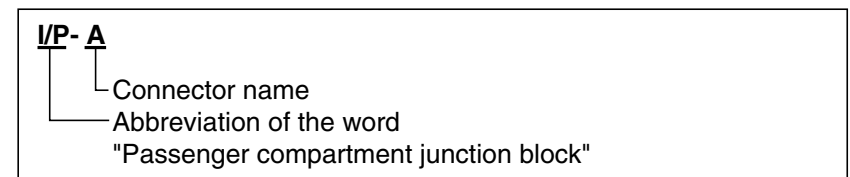

**HARNESS LAYOUTS**

Harness layouts show the routing of the major wiring harnesses, the in-line connectors and the splices between the major harnesses. These layouts will make electrical troubleshooting easier.

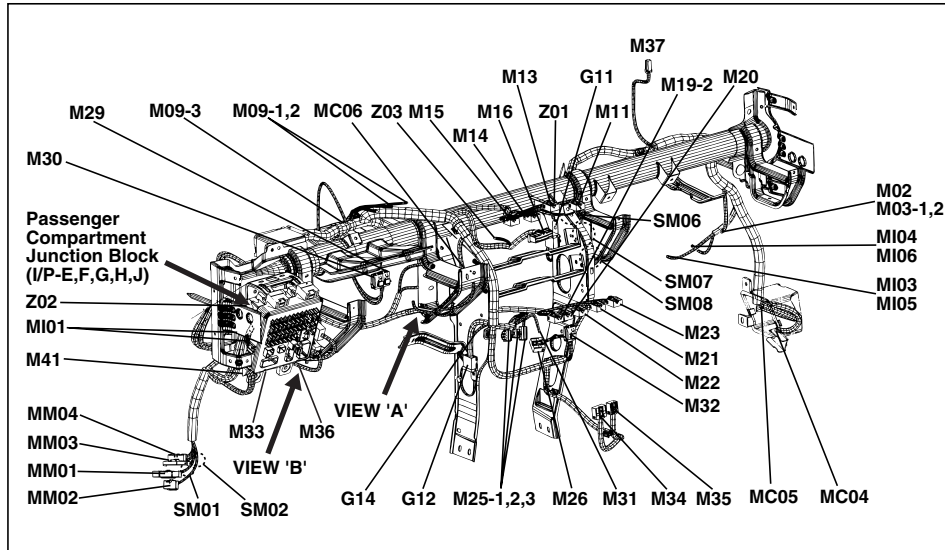









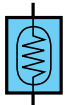
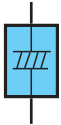

SYMBOLS (1)

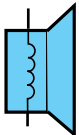
Section	Symbol	Meaning	Section	Symbol	Meaning	Section	Symbol	Meaning	Section	Symbol	Meaning
C O M P O N E N T		A solid line means the entire component is shown.	C O N N E C T O R		Shows the name of each connector on the component location index for reference. Indicates the number of corresponding terminal. (Only relevant terminal on the corresponding schematic diagram).	S H I E L D W I R E		This represents RFI (Radio Frequency Interference) Shielding around a wire. The shielding is always connected to ground.	L A M P		Double filament
		A broken line indicates only part of the component is shown.			The dashed-line means each of two wires connect with same connector(E35)			Single filament			
		This means the connector connects directly to the component.	W I R E		A wavy line means the wire is broken but is to be continued.	J O I N T C O N N E C T O R		This is a connector showing the joining wires.	D I O D E		Diode
		This indicates the connector connects to a lead (pigtail), wired directly to the component.			Wire insulation is yellow with a red strip.			Zener diode			
		This indicates a screw terminal on the component.	S P L I C E S		Current path is continued on the same page or another page. The arrow shows the direction of current flow. You should look for the "A" in the marked position.	S O W B L O W		Power supplied at all times. Name Capacity	T R		NPN
		This ground symbol (dot and 3 lines overlapping the component) means the housing of the component is attached to a metal part of the vehicle.			A wire connects to another circuit. The wire is shown again on that circuit which the arrow is pointing.			This means power is supplied with the ignition on position. This means the short bar connects to other fuses. Identification Current rating			PNP
		This indicates a screw terminal on the component.	G R O U N D		Wire choices for options or different models are labeled and shown with a "choice" bracket like this.	F U S E			G E N E R A L C O M P O N E N T S Y M B O L		These switches move together: a dashed line shows a mechanical connection between them.
		This ground symbol (dot and 3 lines overlapping the component) means the housing of the component is attached to a metal part of the vehicle.			Splices are numbered and shown as a dot with circle. The exact location and connection of these splices may vary among vehicles.						Switch (1 contact point)
	The name of the component appears next to its upper right corner. Shows the number of pictures for component location.			This symbol means the end of the wire is attached to a metal part of the vehicle.	C O N T R O L L O C A T I O N		Heater				

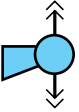
# SYMBOLS

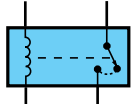
## SYMBOLS (2)

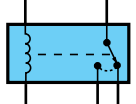
GI-7

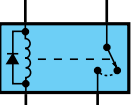
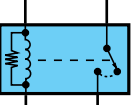
Section	Symbol	Meaning	Section	Symbol	Meaning
GENERAL COMPONENTS SYMBOL		Sensor	GENERAL COMPONENTS SYMBOL		Condenser
		Sender			Speaker
		Injector			Horn, Buzzer, Siren, Chime Bell
		Solenoid	RELAY		Normally open contact
		Motor			This is a relay shown with no current flowing through its coil. When a current flows through coil, contact will toggle.
	Battery			Diode interior relay	
				Resistance interior relay	

## TROUBLESHOOTING INSTRUCTIONS (1)

GI-8

## TROUBLESHOOTING INSTRUCTIONS

## TROUBLESHOOTING PROCEDURES

The following five-step troubleshooting procedure is recommended.

**1. Verify the customer's complaints**

Turn on all the components in the problem circuit to check the accuracy of the customer's complaints. Note the symptoms. Do not begin disassembly or testing until you have narrowed down the probable causes.

**2. Read and analyze the schematic diagram**

Locate the schematic for the problem circuit. Determine how the circuit is supposed to work by tracing the current paths from the power source through the system components to ground. If you do not understand how the circuit should work, read the circuit operation text. Also check other circuits that share with the problem circuit. The name of circuits that share the same fuse, ground, or switch, for example, are referred to on each diagram. Try to operate any shared circuits you did not check in step 1. If the shared circuit works, the shared wiring is okay, and the cause must be within the wiring used only by the problem circuit.

If several circuits fail at the same time, the fuse or ground is a likely cause.

**3. Inspect the circuit/ component with the problem isolated**

Make a circuit test to check the diagnosis you made in step 2. Remember that a logical, simple procedure is the key to efficient troubleshooting. Narrow down the probable causes using the troubleshooting hints and system diagnosis charts. Test for the most likely cause of failure first. Try to make tests at points that are easily accessible.

**4. Repair the problem**

Once the problem is found, make the necessary repairs.

**5. Make sure the circuit works**

Repeat the system check to be sure you have repaired the problem. If the problem was a blown fuse, be sure to test all of the circuits on that fuse.

## TROUBLESHOOTING EQUIPMENT

**VOLTMETER AND TEST LAMP**

Use a test lamp or a voltmeter on circuits without solidstate units and use a test lamp to check for voltage. A test lamp is made up of a 12-volt light bulb with a pair of leads attached. After grounding one lead, touch the other lead to various points along the circuit where voltage should be present. When the bulb goes on, there is voltage at the point being tested.

**CAUTION**

**A number of circuits include solid-state modules, such as the Engine Control Module(ECM), used with computer command control injection. Voltage in these circuits should be tested only with a 10-megaohm or higher impedance digital multimeter. Never use a test lamp on circuits that contain solid state modules. Damage to the modules may result.**

A voltmeter can be used in place of a test lamp. While a test lamp shows whether the voltage is present or not, a voltmeter indicates how much voltage is present.

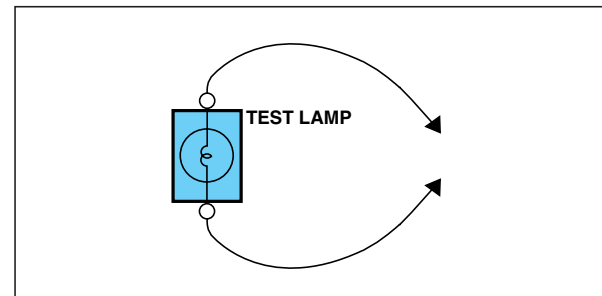
**SELF-POWERED TEST LAMP AND OHMMETER**

Use a self-powered test lamp or an ohmmeter to check for continuity. The ohmmeter shows how much resistance there is between two points along a circuit. Low resistance means good continuity.



## TROUBLESHOOTING INSTRUCTIONS

### TROUBLESHOOTING INSTRUCTIONS (2)

GI-9

#### CAUTION

**Never use a self-powered test lamp on circuits that contain solid state modules. Damage to these modules may result.**

An ohmmeter can be used in place of a self-powered test lamp. The ohmmeter shows how much resistance there is between two points along a circuit. Low resistance means good continuity.

Circuits which include any solid-state devices should be tested only with a 10-megaohm or higher impedance digital multimeter. When measuring resistance with a digital multimeter, the battery negative terminal should be disconnected. Otherwise, there may be incorrect readings. Diodes and solid-state devices in a circuit can make an ohmmeter give a false reading. To find out if a component is affecting a measurement, take one reading, reverse the leads and take a second reading. If different the solid-state device is affecting the measurement.

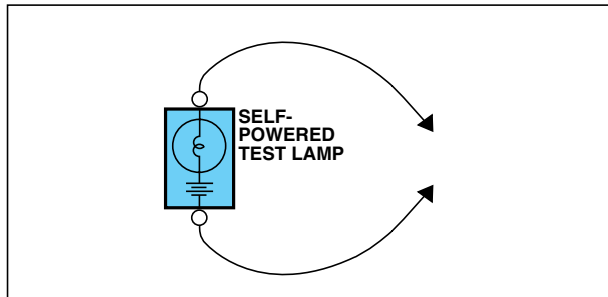

#### JUMPER WIRE WITH FUSE

Use a jumper wire with a fuse to by-pass an open circuit.

A jumper wire is made up of an in-line fuse holder connected to a set of test leads. This tool is available with small clamp connectors providing adaption to most connectors without damage.

#### CAUTION

**Do not use a fuse with a higher rating than the specified fuse that protects the circuit being tested. Do not use this tool in any situation to substitute an input or output at the solid-state control module, such as ECM, TCM, etc.**

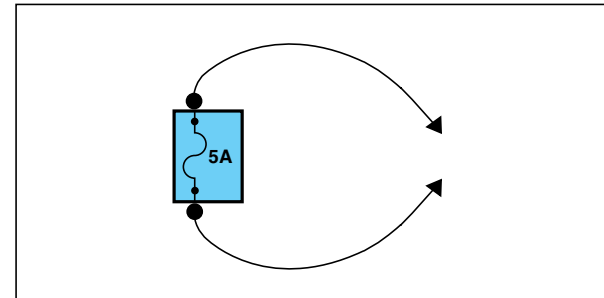

#### SHORT FINDER

A short finder is available to locate a short to ground. The short finder creates a pulsing magnetic field in the shorted circuit and shows you the location of the short through body trim or sheet metal.

#### TROUBLESHOOTING TEST

##### 1. TESTING FOR VOLTAGE

This test measures voltage in a circuit. When testing for voltage at a connector, you do not have to separate the two halves of the connector. Instead, probe the connector from the back(backprobe). Always check both sides of the connector because dirt and corrosion between its contact surfaces can cause electrical problems.

- A. Connect one lead of a test lamp or voltmeter to a ground. If you are using a voltmeter, be sure it is the voltmeter's negative test lead you have connected to ground.
- B. Connect the other lead of the test lamp or voltmeter to a selected test point(connector or terminal).
- C. If the test lamp glows, there is voltage present. If you are using a voltmeter, note the voltage reading. A loss of more than 1 volt from specification indicates a problem.

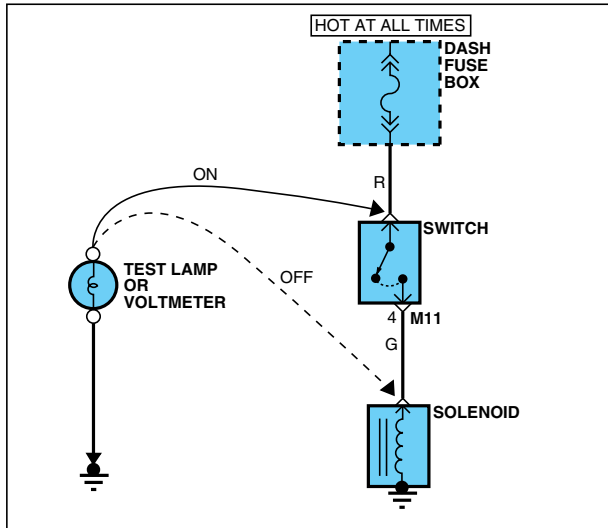

**2. TESTING FOR CONTINUITY**

- A. Disconnect the battery negative terminal.
- B. Connect one lead of a self-powered test lamp or ohmmeter to one end of the part of the circuit you wish to test. If you are using an ohmmeter, hold the leads together and adjust the ohmmeter to read zero ohms.
- C. Connect the other lead to the other end.
- D. If the self-power test lamp glows, there is continuity. If you are using an ohmmeter, low or zero resistance means good continuity.

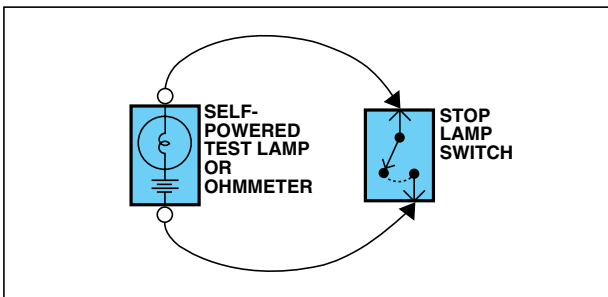

**3. TESTING FOR SHORT TO GROUND**

- A. Disconnect the battery negative terminal.
- B. Connect one lead of a self-powered test lamp or an ohmmeter to the fuse terminal on the load side.
- C. Connect the other lead to a ground.
- D. Beginning near the fuse block move the harness from side to side. Continue this procedure (about six inches apart) while watching the self-powered test lamp or ohmmeter.
- E. When the self-powered test lamp glows, or ohmmeter registers, there is a short to a ground in the wiring near that point.

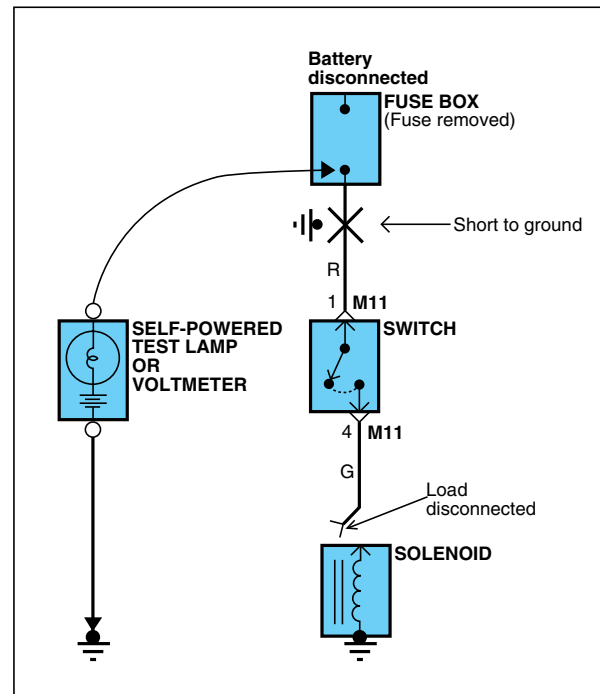

**4. TESTING FOR A SHORT WITH A SHORT FINDER**

- A. Remove the blown fuse. Leave the battery connected.
- B. Connect the short finder across the fuse terminals.
- C. Close all switches in series in the circuit that is being testing.
- D. Turn on the short circuit locator. It sends pulses of current to the short.  
This creates a pulsing magnetic field around the wiring between the fuse box and the short.
- E. Beginning at the fuse box, slowly move the short finder along the circuit wiring. The meter will show current pulses through sheet metal and body trim. As long as the meter is between the fuse and the short, the needle will move with each current pulse. Once the meter is moved past the point of the short, the needle will stop moving. Check around this area to locate the cause of the short circuit.

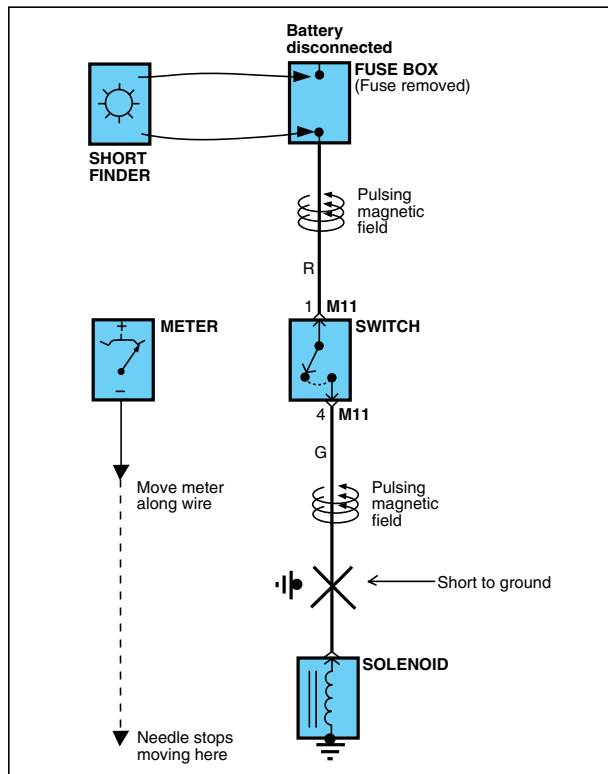

**\* REFERENCE SERVICE TOOLS**

Tool Number	Tool Name
TRK00A	Wiring Repair Kit (Standard Kit)
TRK001	Wire Stripper Set
TRK002	Remover Tool Set
TRK003	Terminal Tension Gauge Set
TRK004	Cable Tie Set
TRK005	Shrink Tube Set
TRK006	Jump Connector Kit(A)
TRK007~10	General Connector Kit(B~E)
TRK011	Terminal With Lead Wire Kit(F)
TRK012	Composition Kit(G)
TRK013	Lead Wire Set
TRK014	Carrying Case
TRK015	User's Guide & Parts Information
TRK016	Inner Box(Large)
TRK017	Inner Box(Small)
TRK018	Solder

\* For more details, refer to the User's guide & parts Information of the Wiring Repair Kit (Pub. No. : OSG200208).

**\* Wiring Repair Kit**

[Standard Kit (TRK00A)]

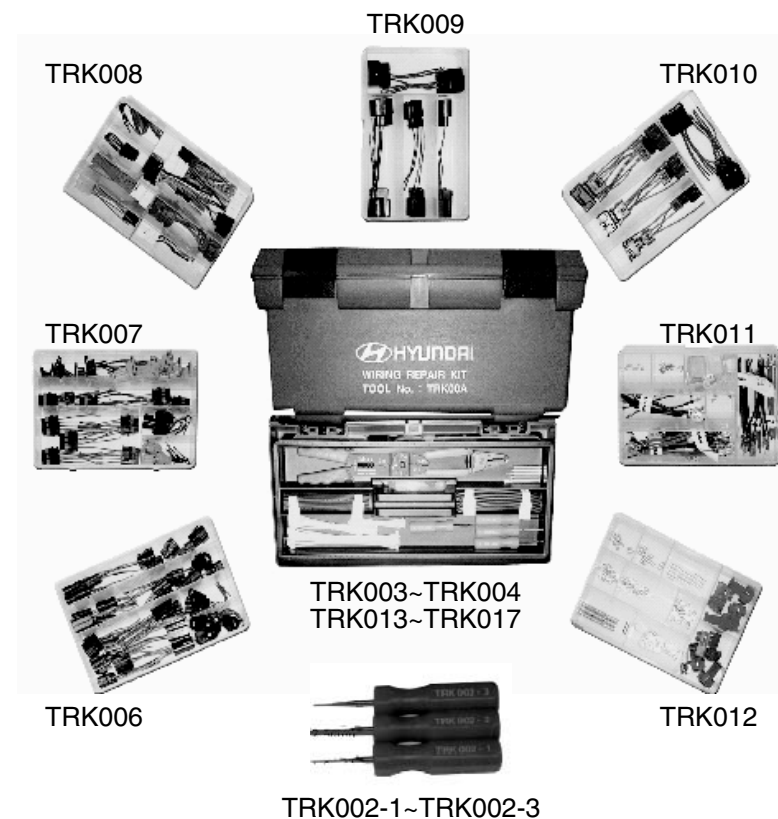

**\* Optional Items**



**REWORK PROCEDURE**

**1. Use of Wire stripper set (TRK001)**

- 1) Disconnect the battery cable.
- 2) Choose the correct clamping slot for the wire and strip off the wire coat.
- ◎ If the incorrect crimping slot is used, the terminal may be damaged and may not fit into the connector.

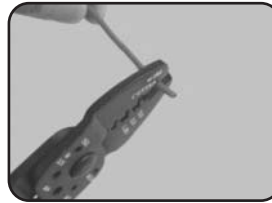

**2. Use of Remover tool set (TRK002)**

► **Flat tip type** : Removal of single locking male/female terminal from the connector.

- 1) Remove the front or rear retainer (holder, stopper) of the connector.



- 2) Ensure that the tip of the tool is inserted into the gap between the elastic arm of key and terminal.



- 3) Remove the terminal and check the terminal condition, if there is a damaged, replace it with a new terminal.

► **Double tip type** : Removal of double locking male/female terminal from the connector.



**3. Use of Terminal tension gauge set (TRK003)**

- 1) Select the tension gauge that matches the female terminal to be checked.



- 2) Insert a tension gauge into the female terminal and check the terminal condition. (as shown in the photograph)



◎ If the tension of female terminal is not tight enough, remove it and replace the terminal and wire assembly (including seal).



### 4. Use of Ring terminal (TRK012-4)

1) Strip off about 5mm of the wire coat at the end of the wire.



2) Joint the stripped wire with ring terminal and crimp using wire stripper.

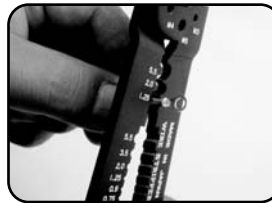

3) Put the shrink tube over the connection area and shrink the tube using electrical hot gun.



### 5. Use of Inline solder (TRK012-5) and Shrink tube set (TRK005)

1) Strip off about 5mm of the wire coat at the end of the wires.



2) Insert each wire into the opposite ends of the inline solder and crimp using wire stripper.



3) Put the shrink tube over the connection area and shrink the tube using electrical hot gun.



◎ Shrink tube should be securely wrapped around the inline solder area.

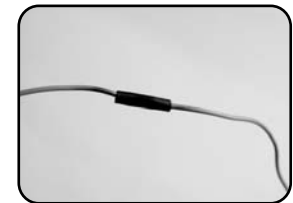

**6. Use of Terminal with lead wire kit (TRK011)**

- 1) Remove the damaged connector and terminal using remover tool.



- 2) Select the right wire, which is fitted with the terminal specification from terminal with lead wire box and cut of the end of wire using wire stripper.

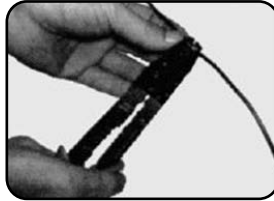

- 3) Put the end of each cut off wire in the middle of the splice joint terminal and compress using wire stripper.



- 4) Put the shrink tube over the connection area and shrink the tube using electrical hot gun.

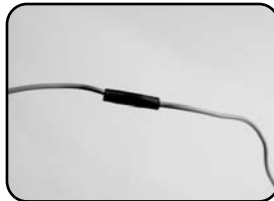

- 5) Insert the terminal with lead wire into the connector.



FUSE & RELAY INFORMATIONS (1)

SD100-1

PASSENGER COMPARTMENT JUNCTION BLOCK LAYOUT

< FRONT >

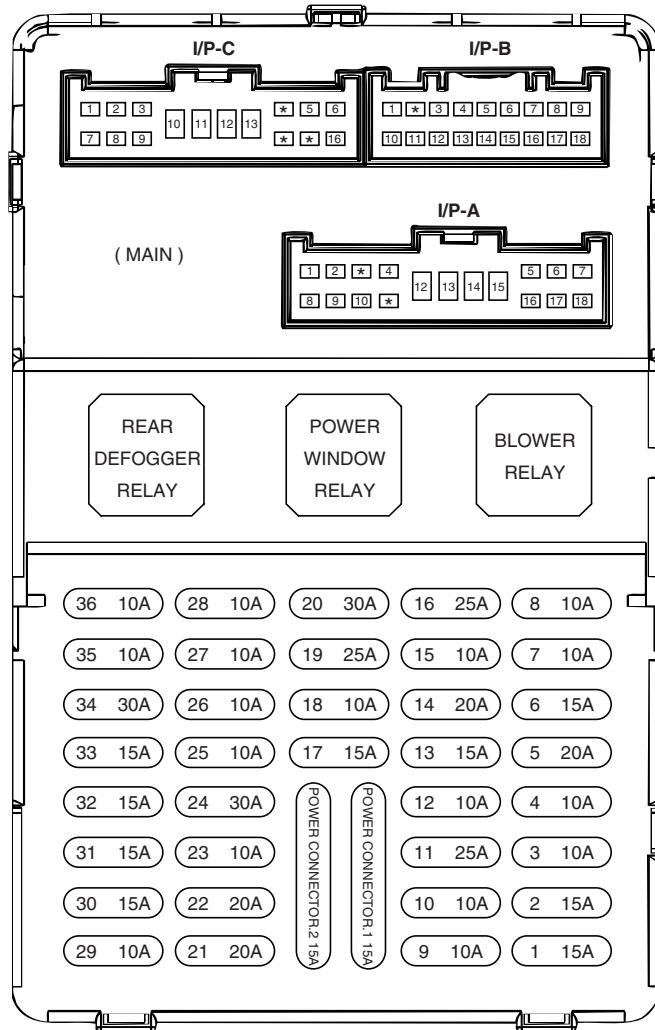

< REAR >

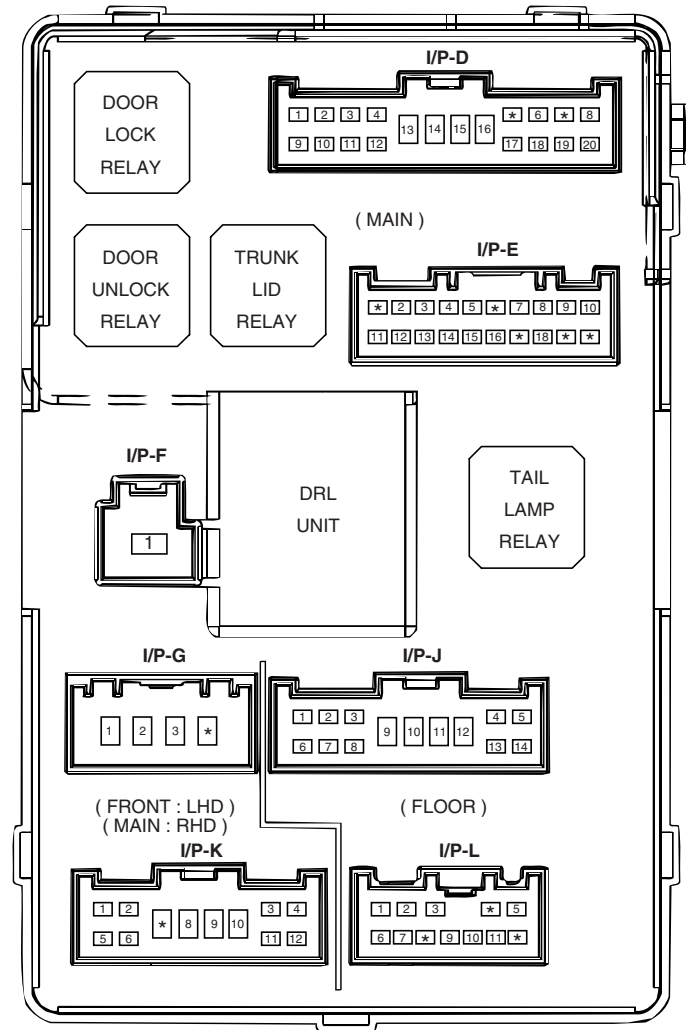

※ USE THE DESIGNATED FUSE ONLY



## FUSE & RELAY INFORMATIONS

### FUSE & RELAY INFORMATIONS (2)

SD100-2

#### CIRCUIT

FUSE	(A)	Circuit Protected
1	15A	(SPARE)
2	15A	Seat warmer switch
3	10A	BCM, Sunroof control module, Electronic chrome mirror, Rheostat
4	10A	Blower relay, Active incar & humidity sensor
5	20A	Cigarette lighter
6	15A	(SPARE)
7	10A	Illumination lamps, Right : License lamp, Rear combination lamp, Head lamp, Glove box lamp
8	10A	Front fog lamp relay, Left : License lamp, Rear combination lamp, Head lamp
9	10A	Head lamp washer relay, Right head lamp leveling actuator
10	10A	DRL control module, Head lamp relay, AQS & ambient sensor, PTC heater relay
11	25A	Wiper & washer
12	10A	A/C control module
13	15A	SRS control module, PAB switch
14	20A	Front accessory socket, Rear power outlet
15	10A	Digital clock, Audio, ATM key lock control module, Power outside mirror & mirror folding
16	25A	Safety window module
17	15A	(SPARE)
18	10A	ATM key lock control module
19	25A	Power window main switch, Left rear power window switch
20	30A	Power window main switch, Right power window switch
21	20A	Audio amp
22	20A	Door lock/unlock relay, Dead lock relay
23	10A	Hazard switch, Hazard relay
24	30A	Power seat manual switch (RHD)
25	10A	Instrument cluster
26	10A	Hazard switch
27	10A	BCM, Instrument cluster, Yaw rate sensor, ESP switch, Pre-Excitation resistor
28	10A	AGCS module
29	10A	Burglar alarm relay
30	15A	(SPARE)
31	15A	Rear fog lamp relay
32	15A	Trunk lid relay, Fuel filler door & Trunk lid switch
33	15A	(SPARE)
34	30A	Power seat manual switch (LHD)
35	10A	Sport mode switch, Key solenoid
36	10A	A/C control module, Outside mirror & mirror folding motor
POWER CONNECTOR.1	15A	Audio
POWER CONNECTOR.2	15A	BCM, Digital clock, Instrument cluster, A/C control module, Courtesy lamps

※ USE THE  
DESIGNATED  
FUSE ONLY

# FUSE & RELAY INFORMATIONS

## FUSE & RELAY INFORMATIONS (3)

SD100-3

### ENGINE COMPARTMENT JUNCTION BLOCK

#### LAYOUT

< FRONT >

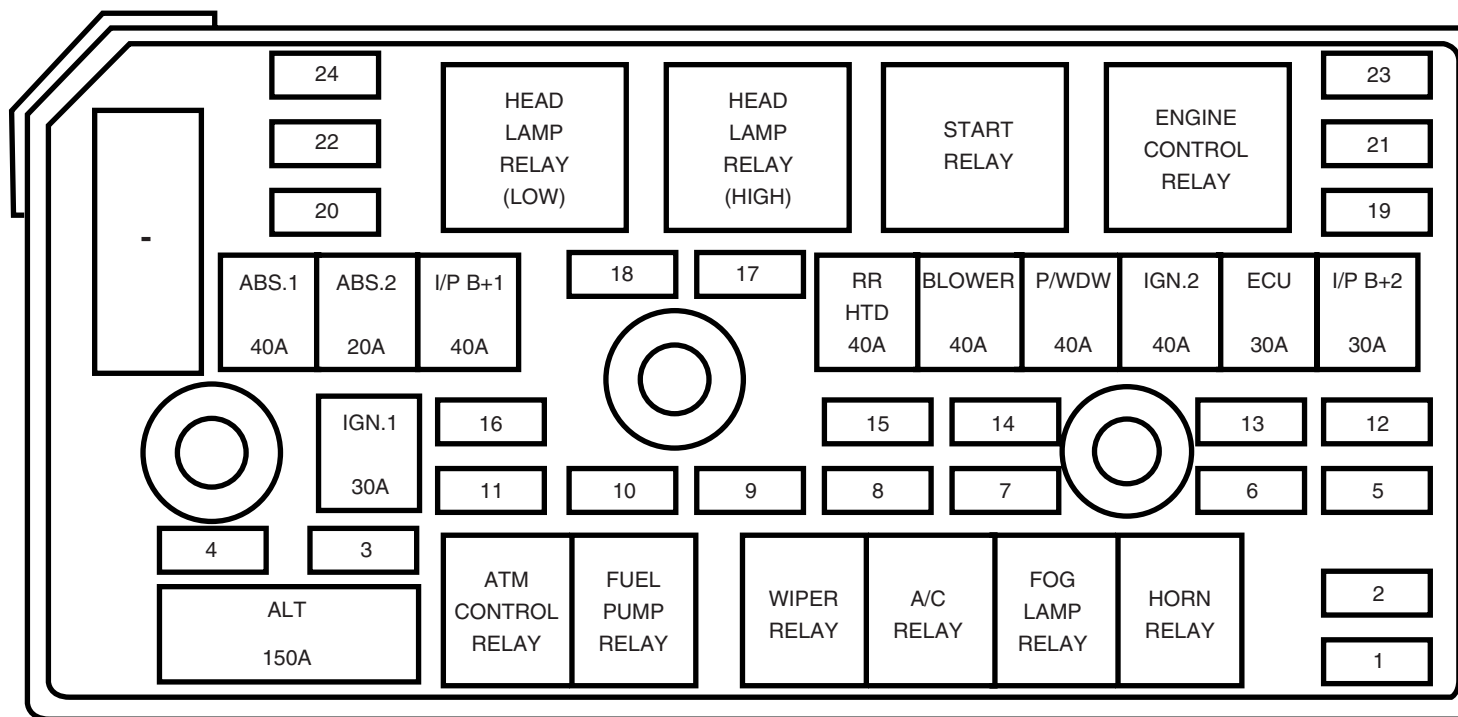

※ USE THE DESIGNATED FUSE ONLY

## FUSE & RELAY INFORMATIONS

### FUSE & RELAY INFORMATIONS (4)

SD100-4

#### CIRCUIT

	Description	(A)	Circuit Protected	
FUSIBLE LINK	ABS.1	40A	ABS/ESP control module, Multipurpose check connector	
	ABS.2	20A	ABS/ESP control module, Multipurpose check connector	
	I/P B+1	40A	Fuse 23, 24, 30, 31, 32, 33, 34, 35	
	RR HTD	40A	Defogger relay	
	BLOWER	40A	Blower relay	
	P/WDW	40A	Power window relay, Fuse 16	
	IGN.2	40A	Start relay, Ignition switch (IG2, START)	
	ECU	30A	Engine control relay	
	I/P B+2	30A	Power connector. 1/2, Fuse 21, 22	
	IGN.1	30A	Ignition switch (ACC, IG1)	
ALT	150A	Fusible link (ABS.1, ABS.2, RR HTD, BLOWER)		
FUSE	1	HORN	15A	Horn relay
	2	TAIL LAMP	20A	Tail lamp relay
	3	ECU	10A	PCM (GSL 3.3L)
	4	IG1	10A	TCM (DSL)
	5	DRL	15A	DRL control module, Burglar horn relay
	6	FR FOG	15A	Front fog lamp relay
	7	A/CON	10A	A/C relay
	8	F/PUMP	20A	Fuel pump relay
	9	DIODE	-	(SPARE)
	10	ATM	20A	ATM control relay
	11	STOP	15A	Stop lamp switch
	12	HID LO RH	15A	(SPARE)
	13	SUN ROOF	15A	Sunroof control module
	14	H/LP WASHER	20A	Head lamp washer motor
	15	H/LP HI	20A	Head lamp relay (High)
	16	ECU(B+)	10A	PCM (GSL), TCM (DSL)
	17	SNSR.3	10A	A/C relay, Cooling fan relay, Injectors (GSL), Lambda sensor (DSL)
	18	SNSR.1	15A	Mass air flow sensor, Oil control valve, SMATRA, Camshaft position sensor
	19	SNSR.2	15A	Fuel pump relay, Oxygen sensor (GSL), VGT actuator (DSL)
	20	B/UP	10A	Back-up lamp switch, Pulse generator, Vehicle speed sensor, Transaxle range switch
	21	IGN COIL	20A	Ignition coils, condenser
	22	ECU(IG1)	10A	PCM (GSL)
	23	H/LP LO	20A	Head lamp relay (Low)
	24	ABS	10A	ABS/ESP control module, Multipurpose check connector

**※ USE THE DESIGNATED FUSE ONLY**

# FUSE & RELAY INFORMATIONS

## FUSE & RELAY INFORMATIONS (5)

SD100-5

### ENGINE COMPARTMENT JUNCTION BLOCK LAYOUT

GSL 2.0L/2.4L

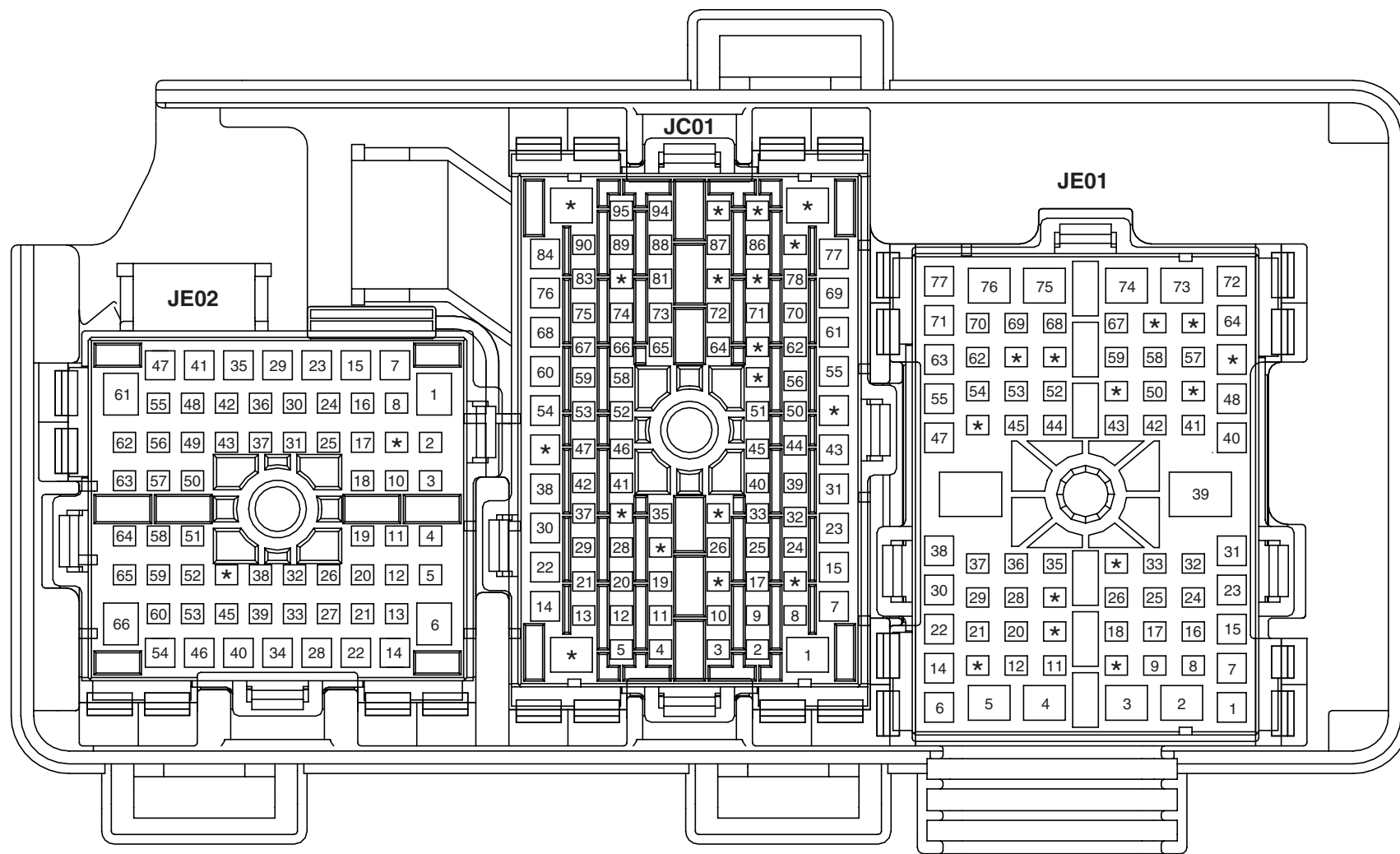

# FUSE & RELAY INFORMATIONS

## FUSE & RELAY INFORMATIONS (6)

SD100-6

### ENGINE COMPARTMENT JUNCTION BLOCK LAYOUT

GSL 3.3L

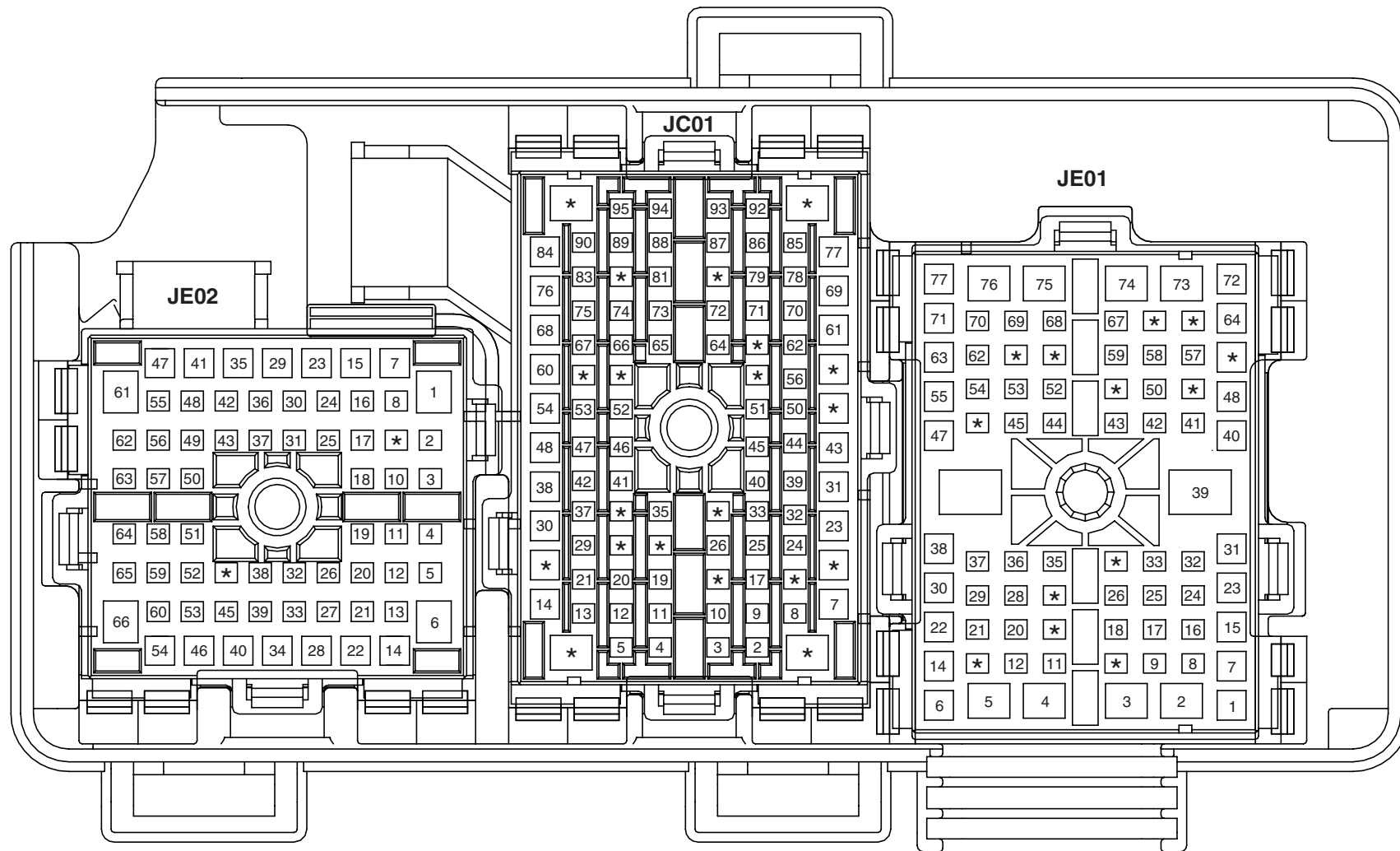

# FUSE & RELAY INFORMATIONS

## FUSE & RELAY INFORMATIONS (7)

SD100-7

### ENGINE COMPARTMENT JUNCTION BLOCK LAYOUT

**DIESEL**

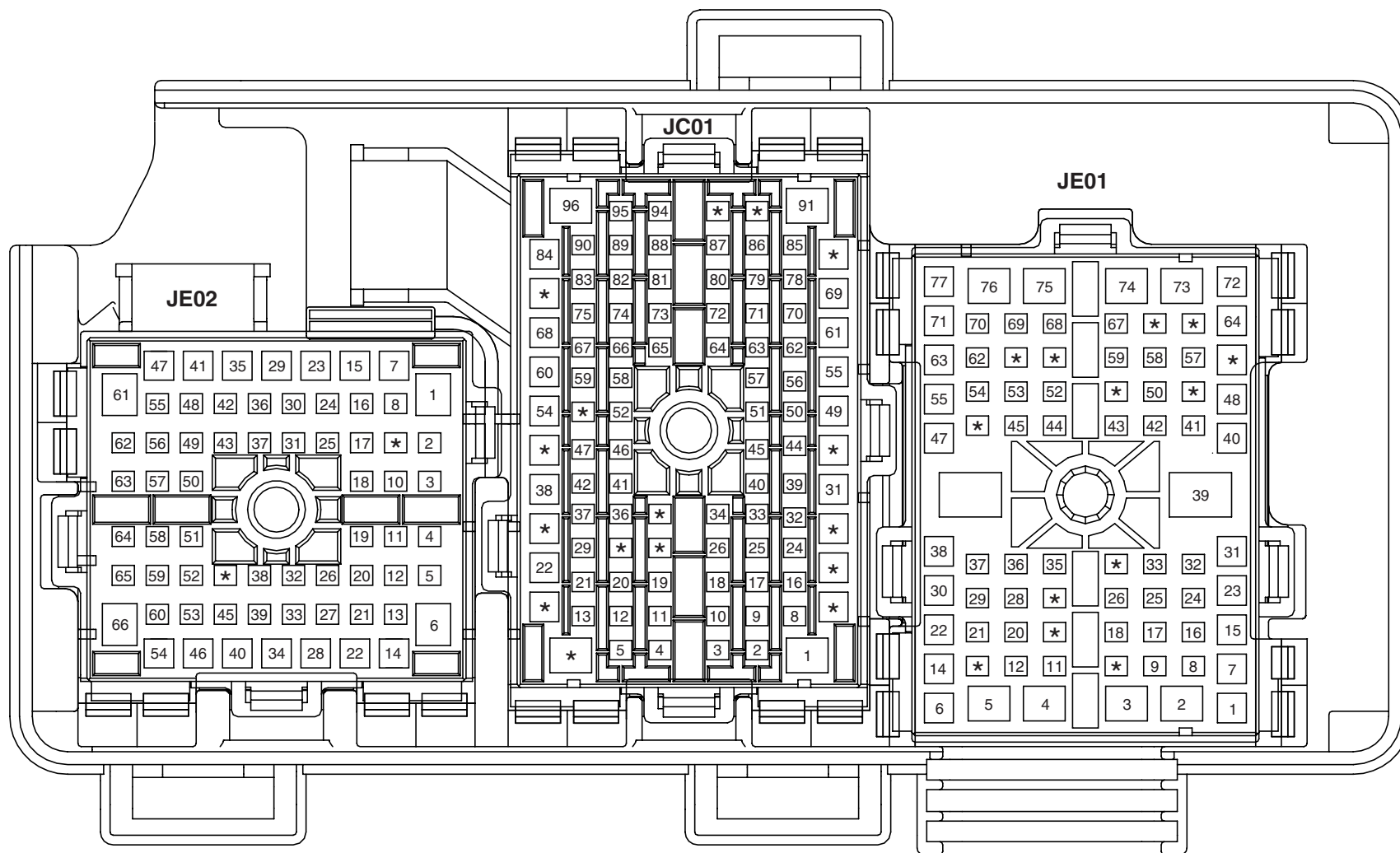

# FUSE & RELAY INFORMATIONS

## FUSE & RELAY INFORMATIONS (8)

SD100-8

### PASSENGER COMPARTMENT RELAY BOX (ICM BOX)

#### LAYOUT

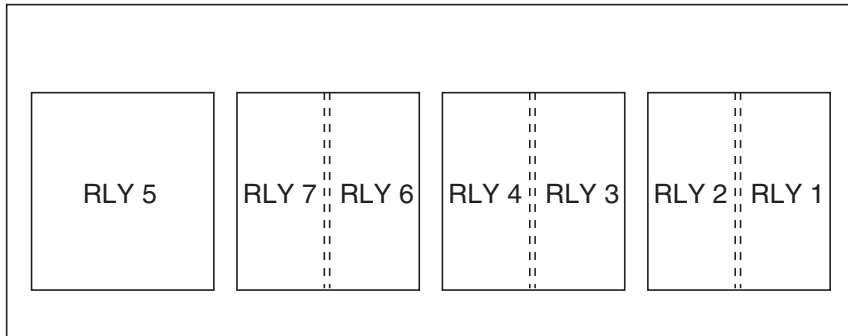

### FUSIBLE LINK BOX (DIESEL)

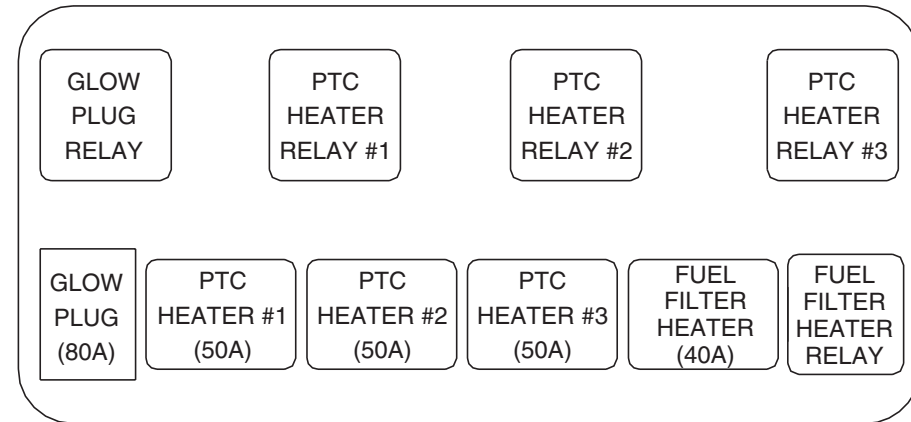

#### RELAY NAME

RELAY NO	RELAY NAME
1	RR FOG
2	DEAD LOCK
3	Not used
4	Not used
5	HAZARD
6	BURGLAR ALARM
7	BURGLAR HORN

FUSIBLE LINK	(A)	Circuit Protected
GLOW PLUG	80A	Glow plug relay
PTC HEATER #1	50A	PTC heater relay #1
PTC HEATER #2	50A	PTC heater relay #2
PTC HEATER #3	50A	PTC heater relay #3
FUEL FILTER HEATER	40A	Fuel filter heater relay

**※ USE THE DESIGNATED FUSE ONLY**

POWER DISTRIBUTION (1)

SD110-1

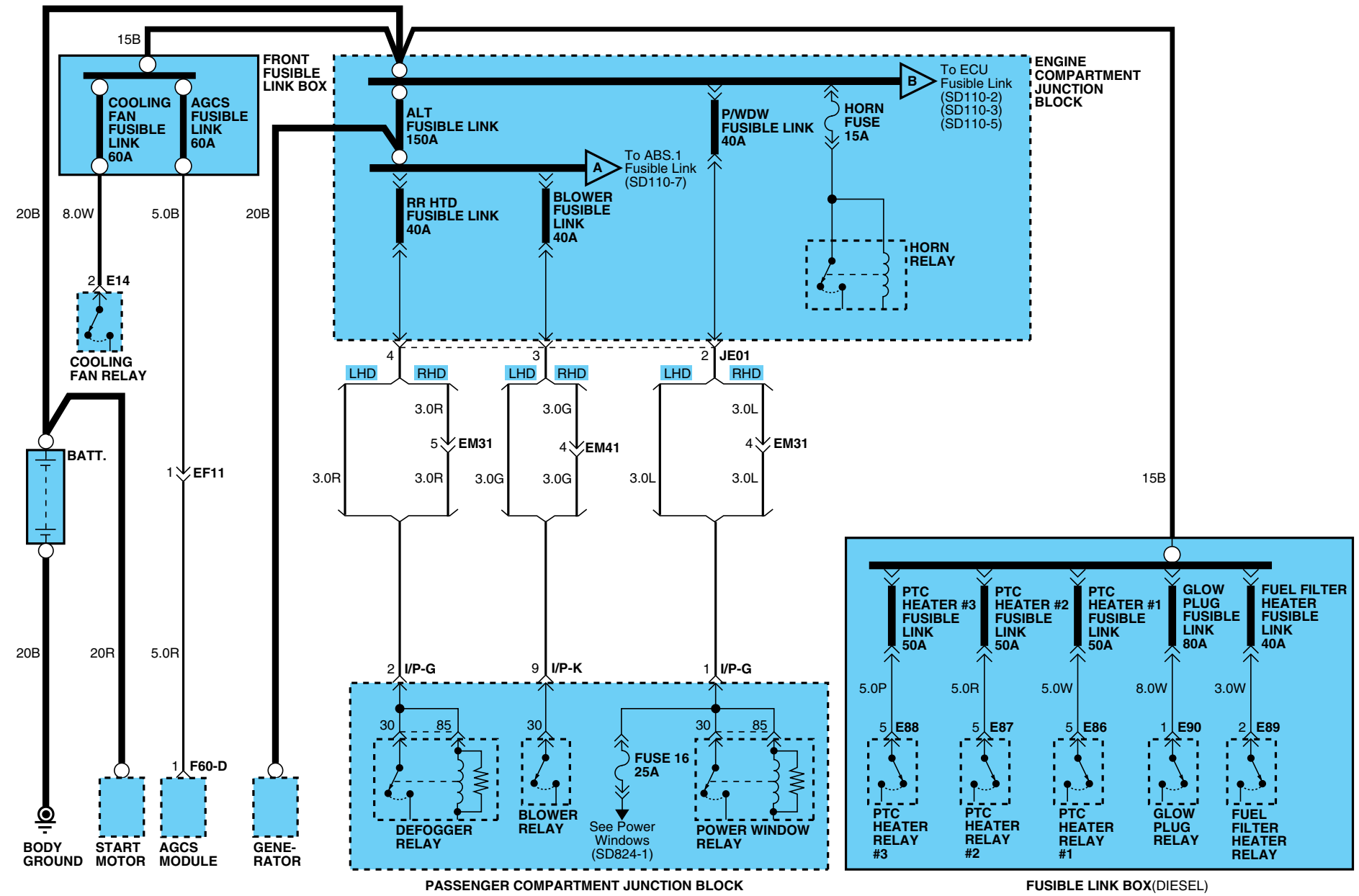



# POWER DISTRIBUTION

## POWER DISTRIBUTION (2)

SD110-2

**GSL 2.0L/2.4L**

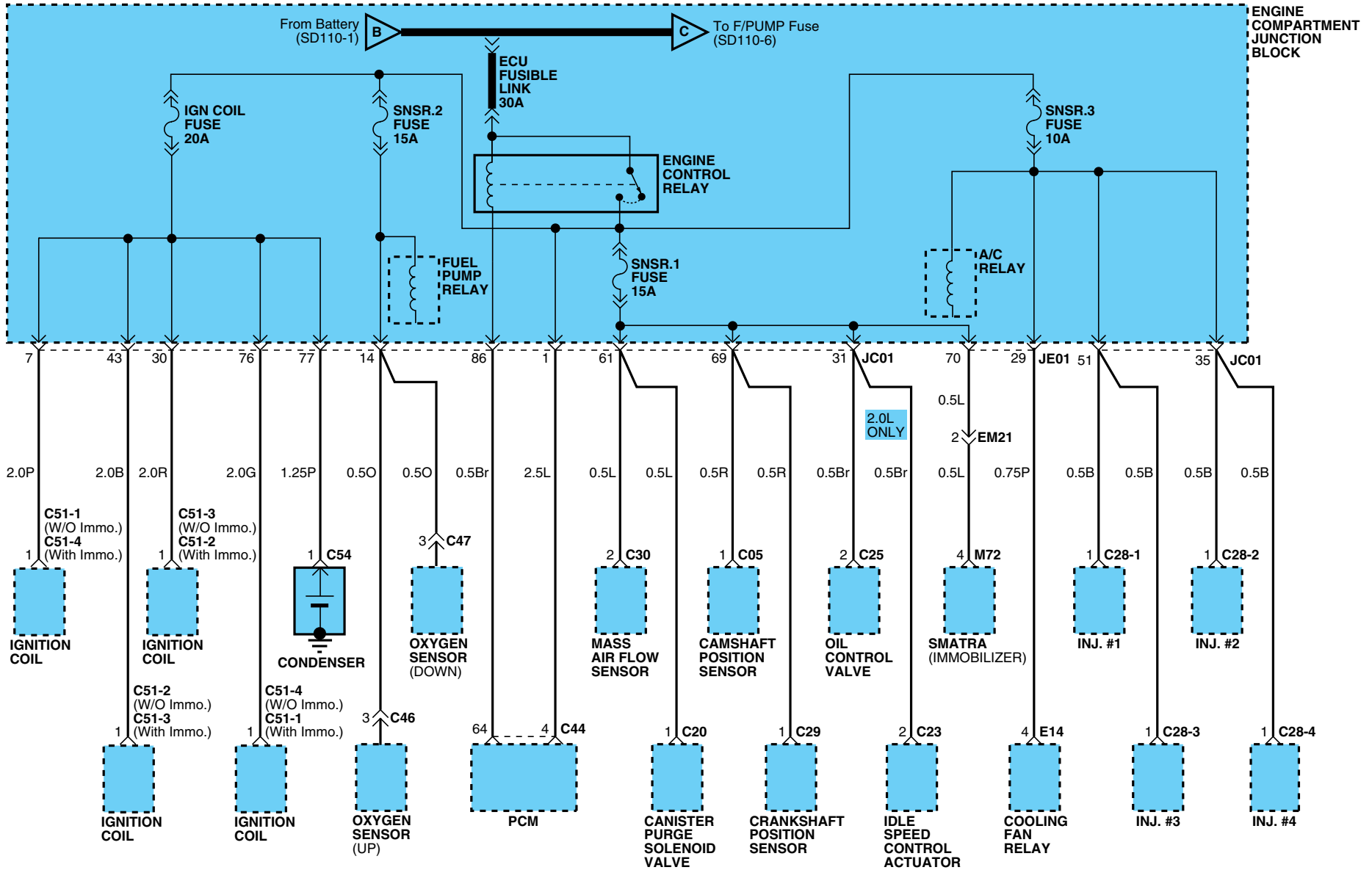

**POWER DISTRIBUTION**

**POWER DISTRIBUTION (3)**

**SD110-3**

**GSL 3.3L**

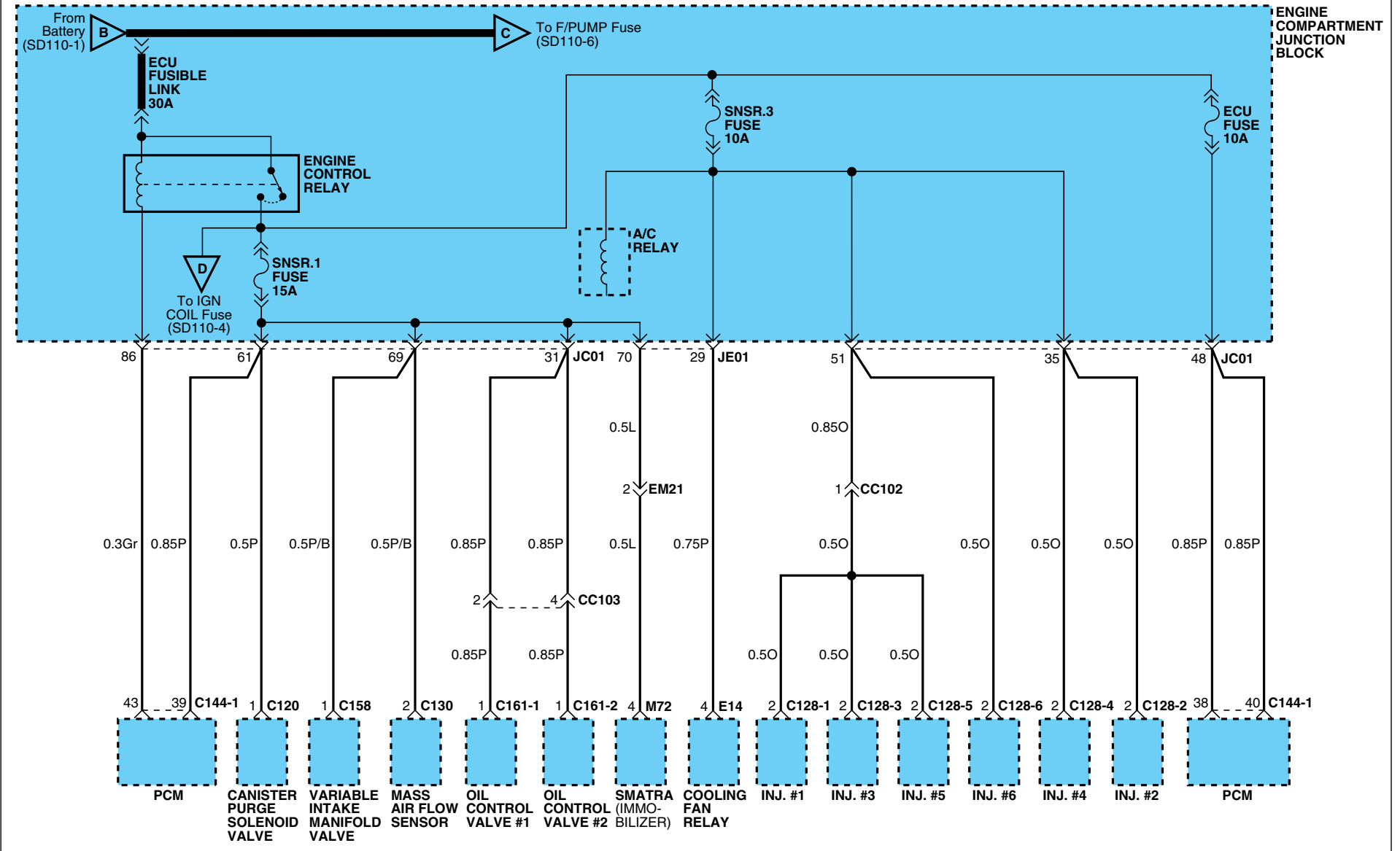

# POWER DISTRIBUTION

## POWER DISTRIBUTION (4)

SD110-4

### GSL 3.3L

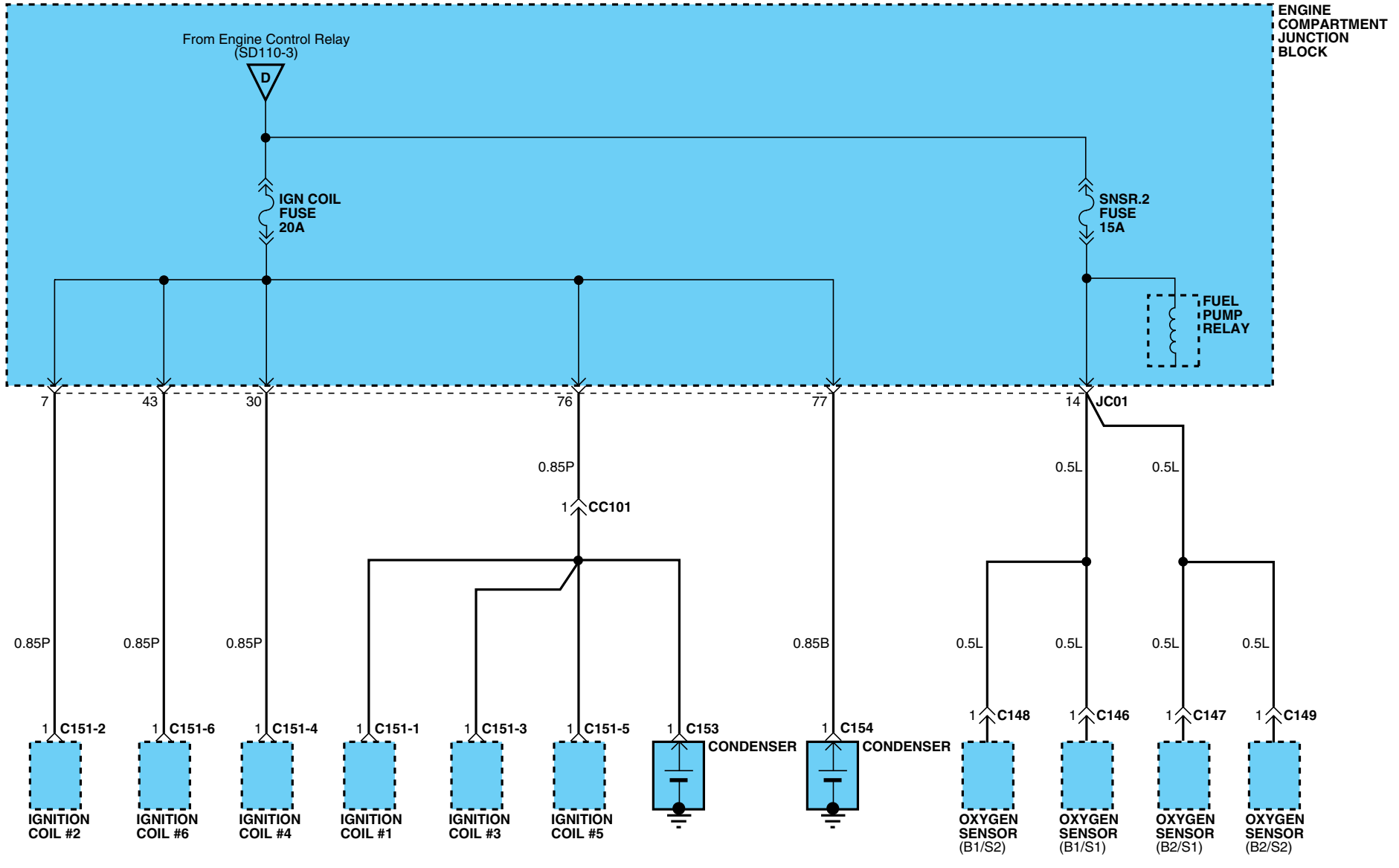

# POWER DISTRIBUTION

## POWER DISTRIBUTION (5)

SD110-5

**DIESEL**

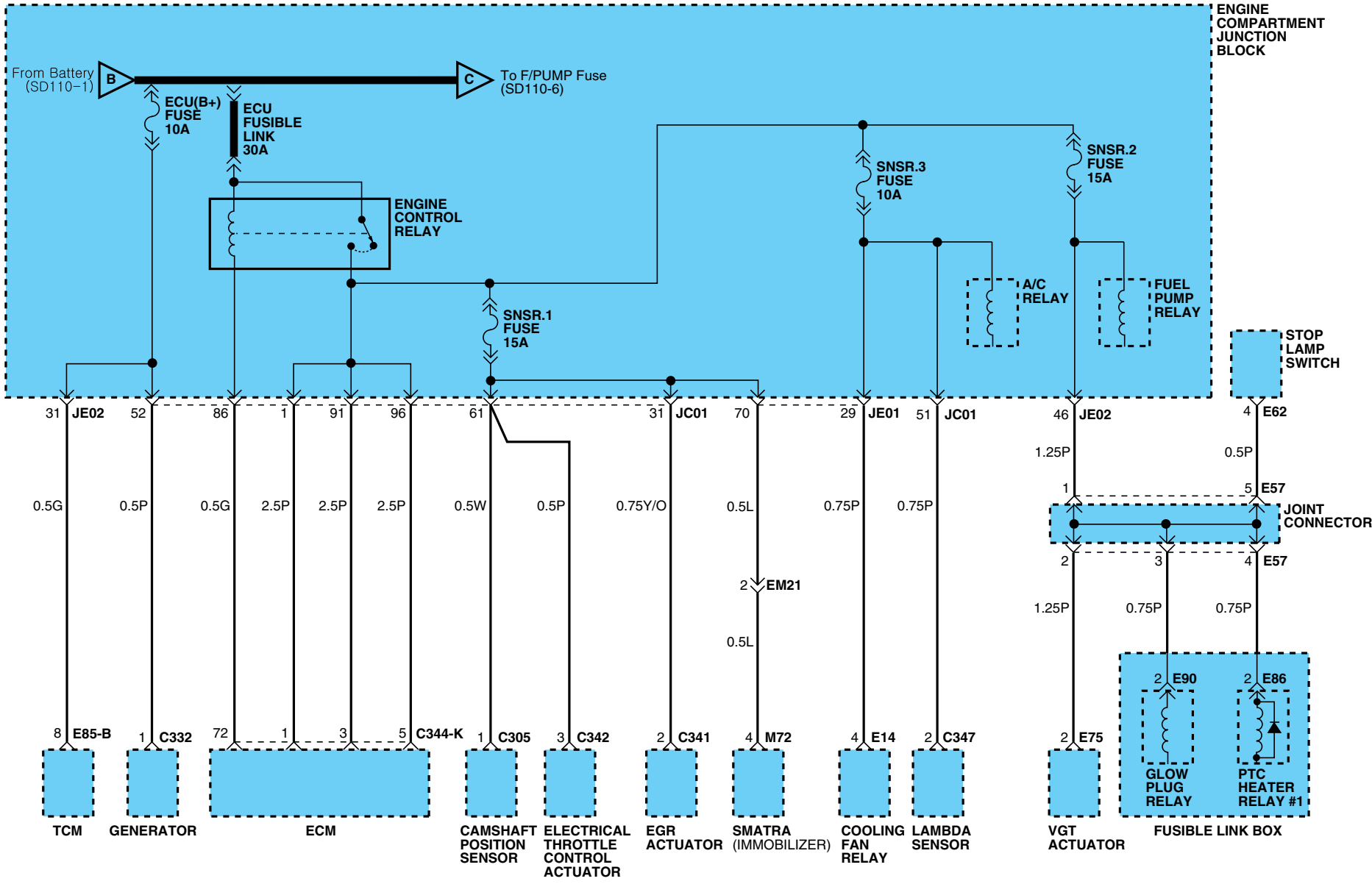

# POWER DISTRIBUTION

## POWER DISTRIBUTION (6)

SD110-6

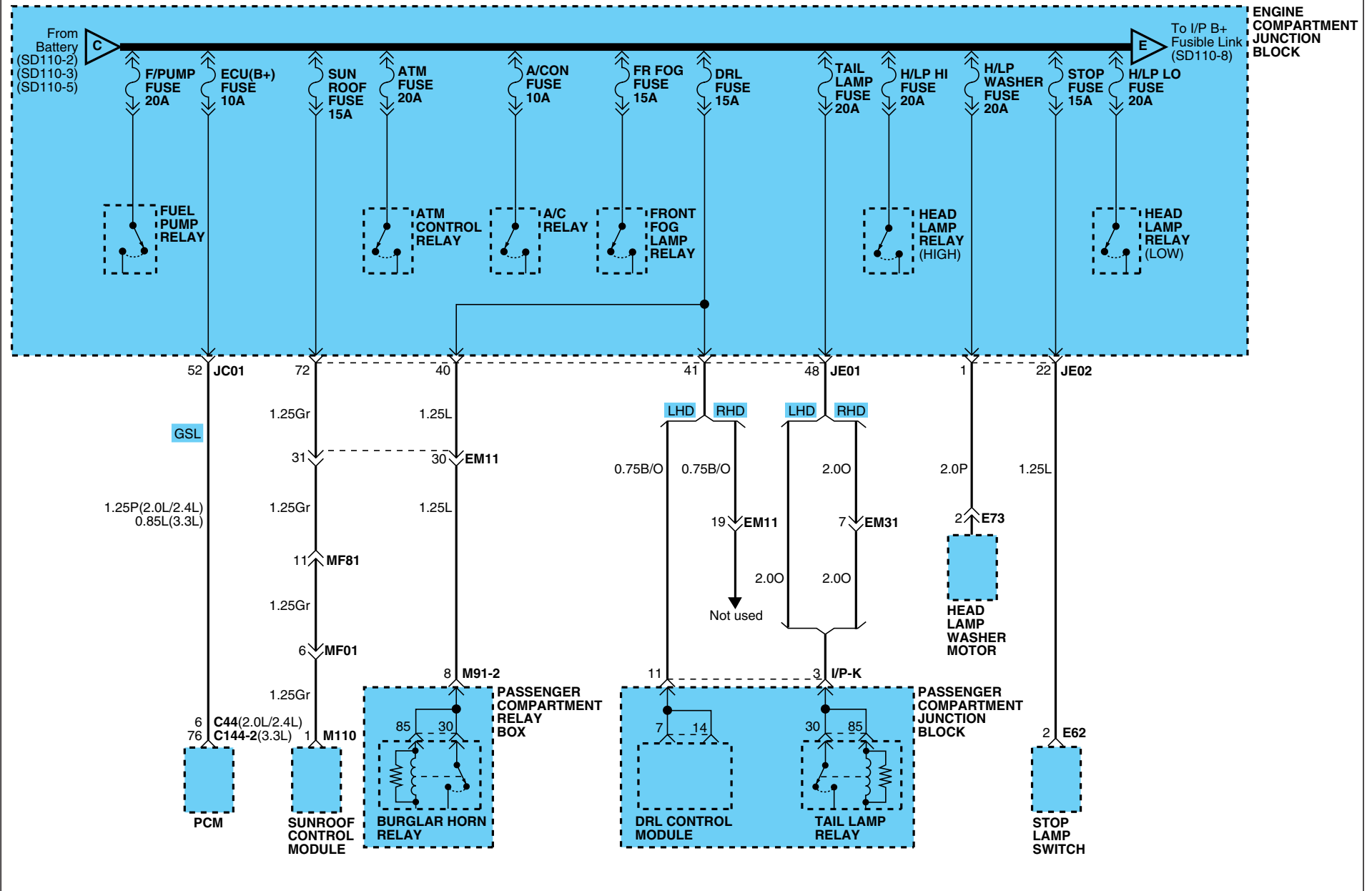

# POWER DISTRIBUTION

## POWER DISTRIBUTION (7)

SD110-7

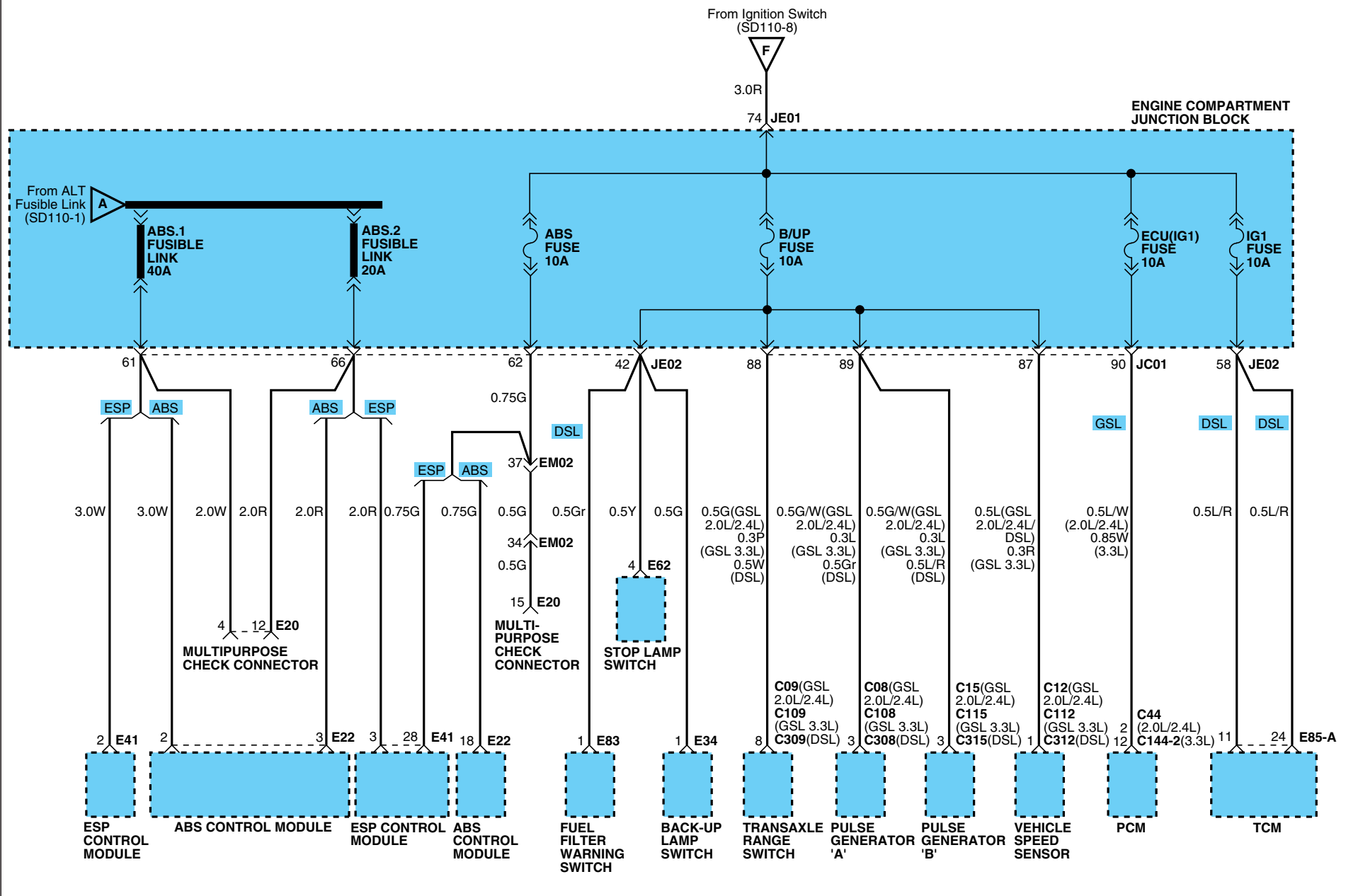

POWER DISTRIBUTION

POWER DISTRIBUTION (8)

SD110-8

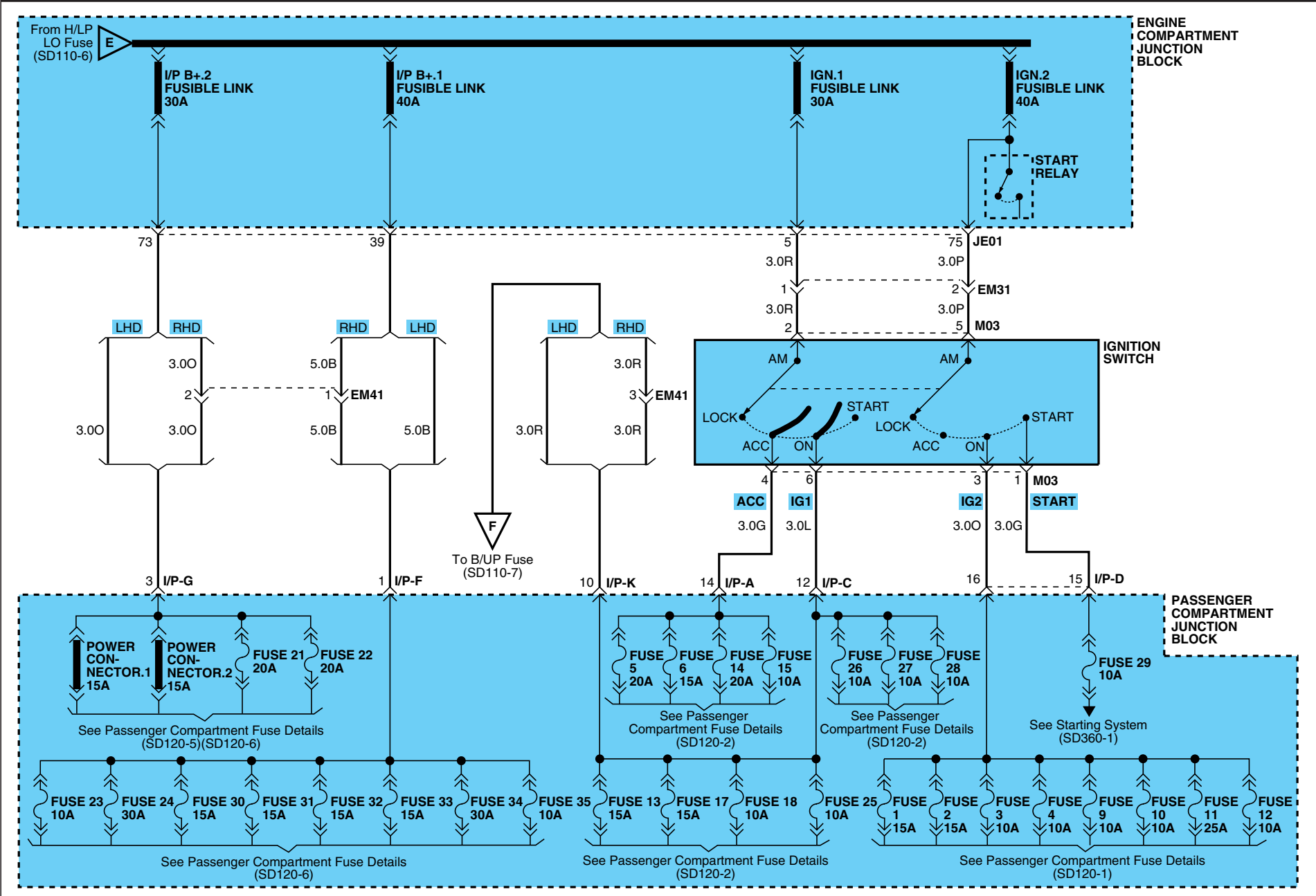

PASSENGER COMPARTMENT FUSE DETAILS (1)

SD120-1

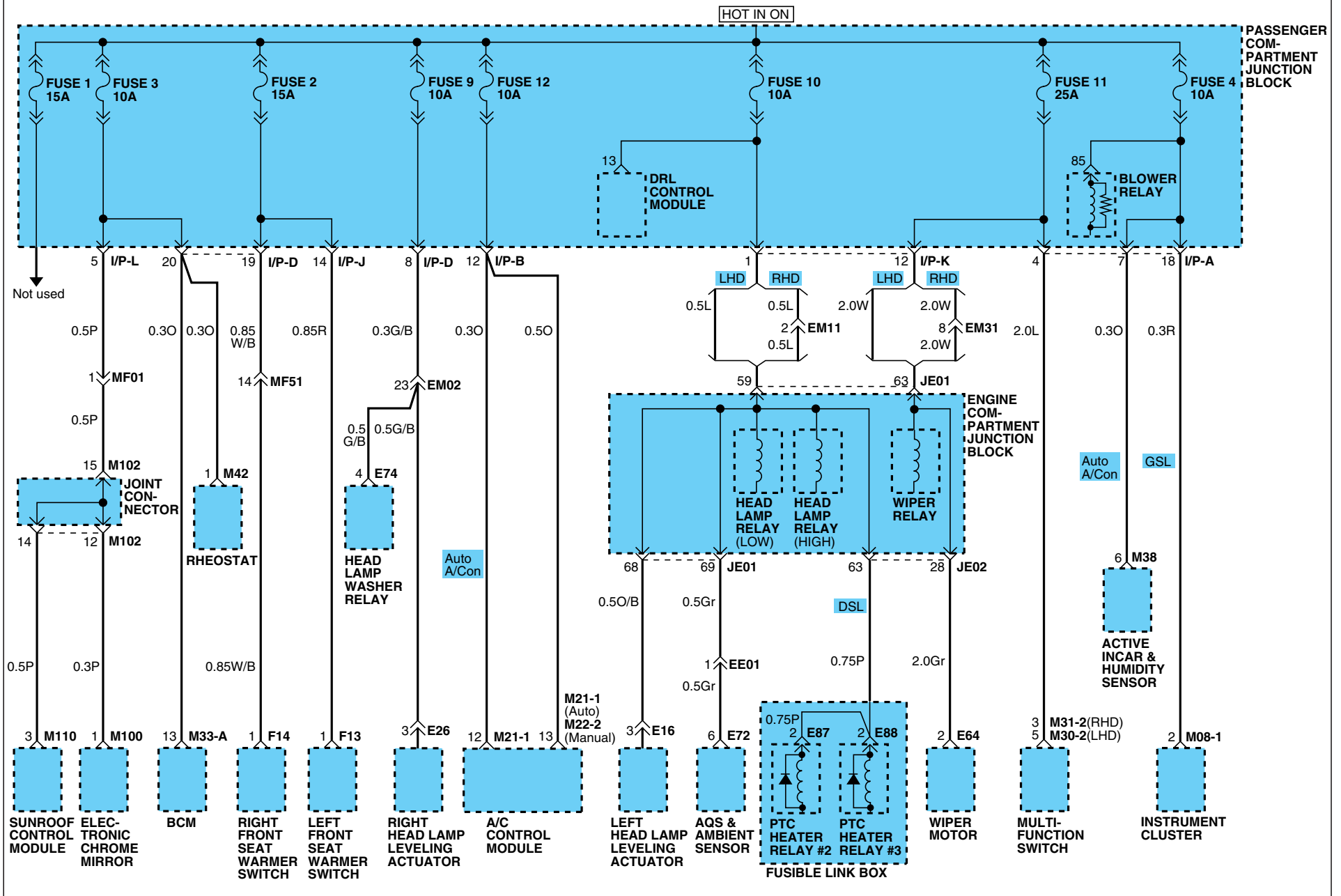



# PASSENGER COMPARTMENT FUSE DETAILS

## PASSENGER COMPARTMENT FUSE DETAILS (2)

SD120-2

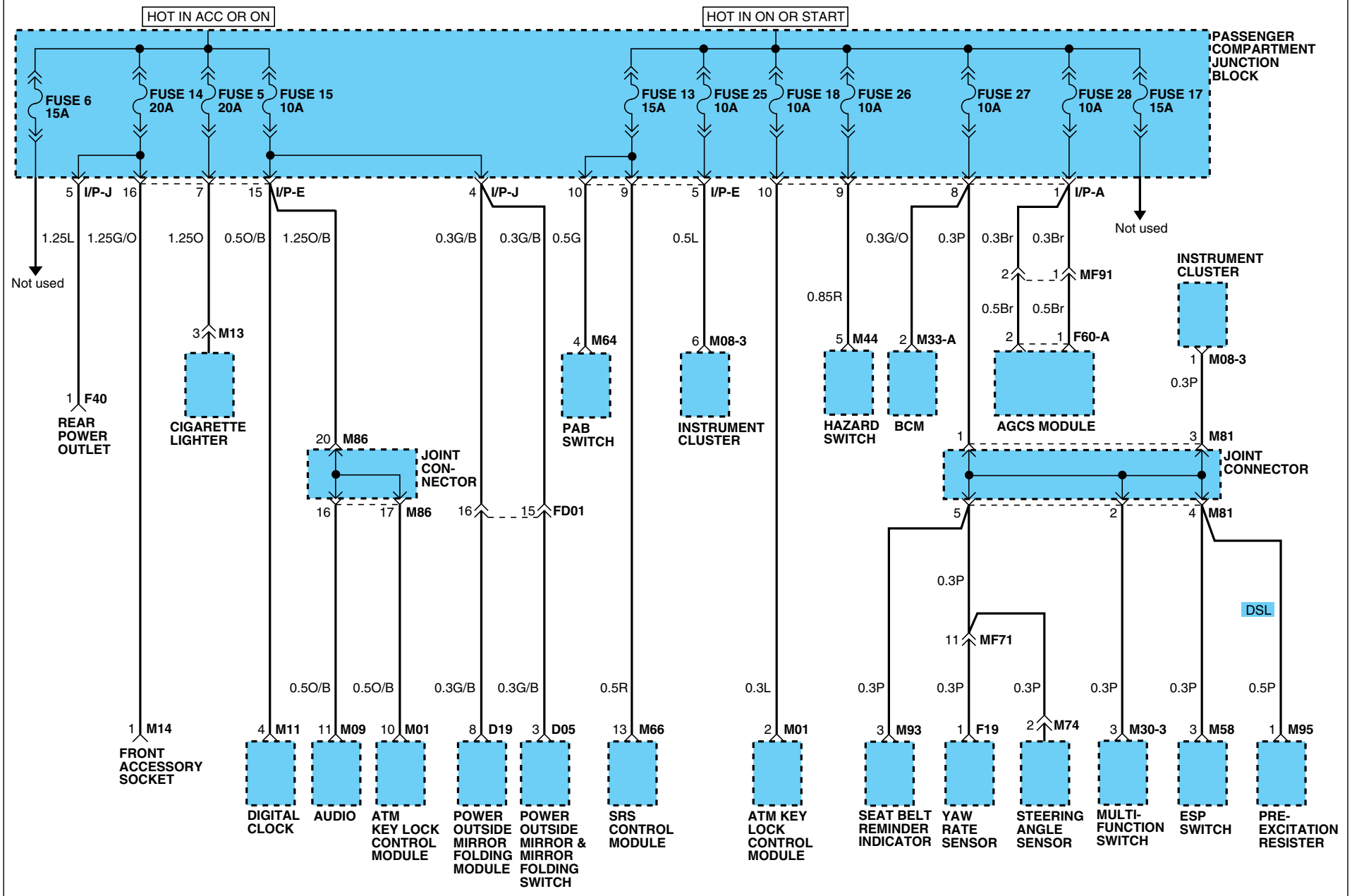

# PASSENGER COMPARTMENT FUSE DETAILS

## PASSENGER COMPARTMENT FUSE DETAILS (3)

SD120-3

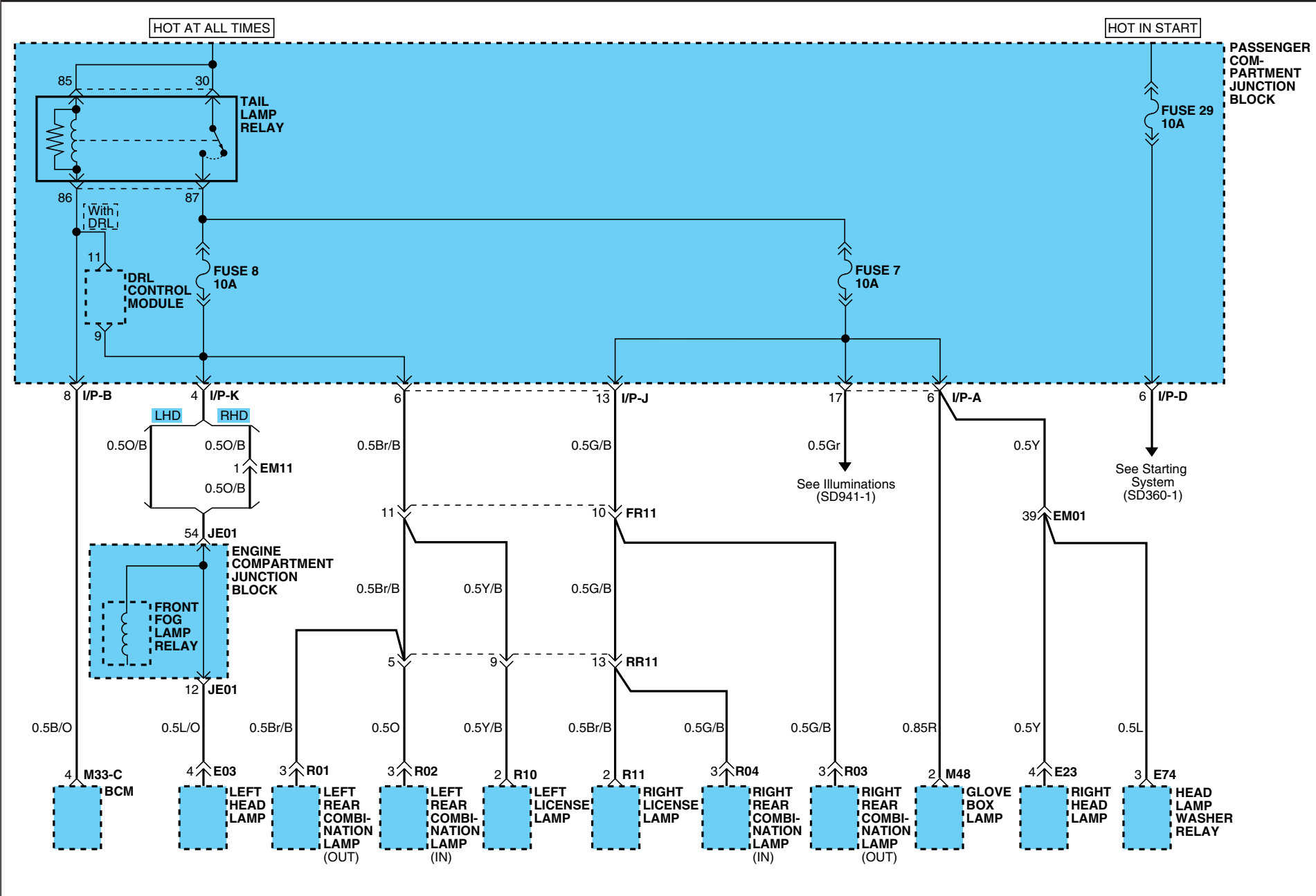

# PASSENGER COMPARTMENT FUSE DETAILS

## PASSENGER COMPARTMENT FUSE DETAILS (4)

SD120-4

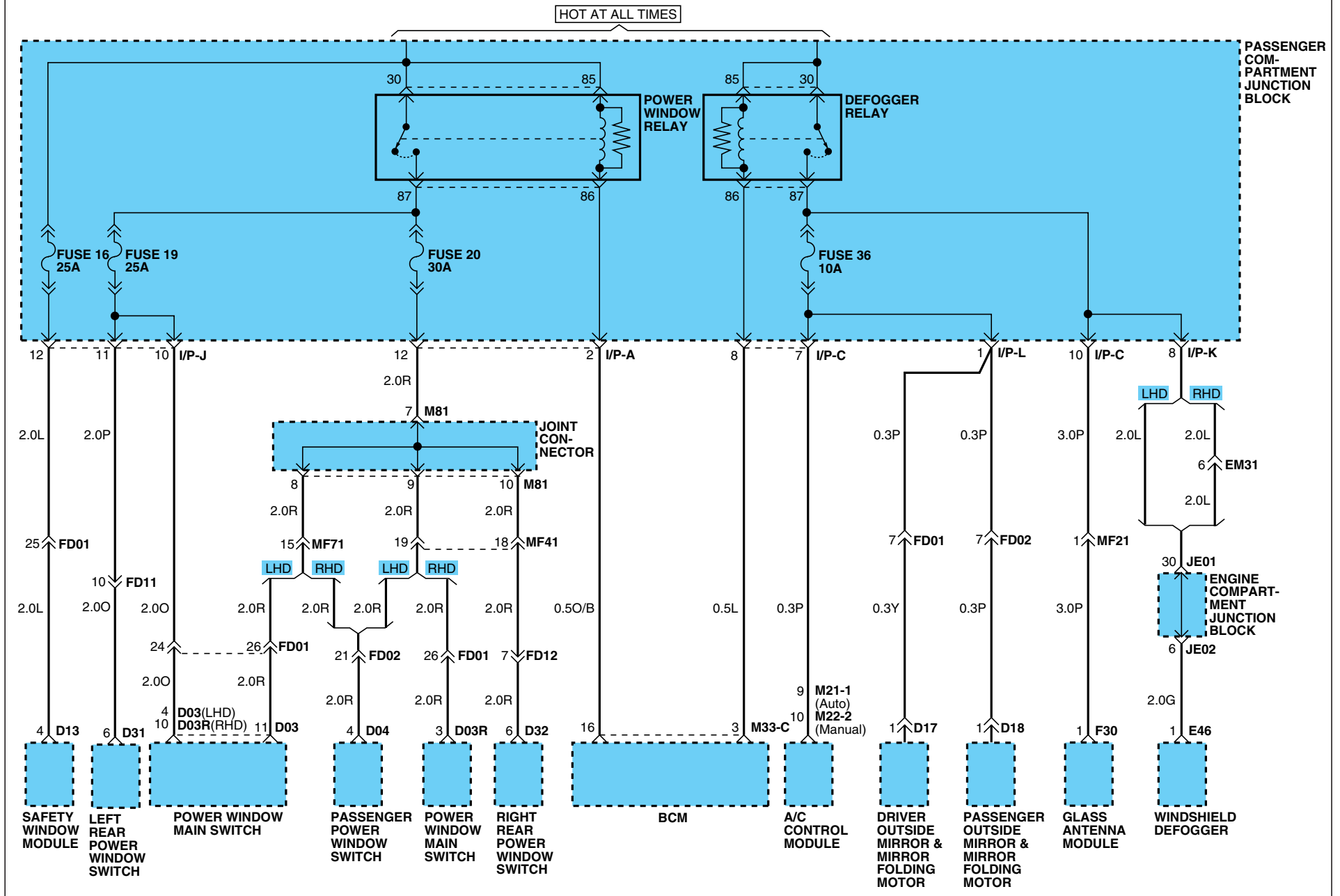

# PASSENGER COMPARTMENT FUSE DETAILS

## PASSENGER COMPARTMENT FUSE DETAILS (5)

SD120-5

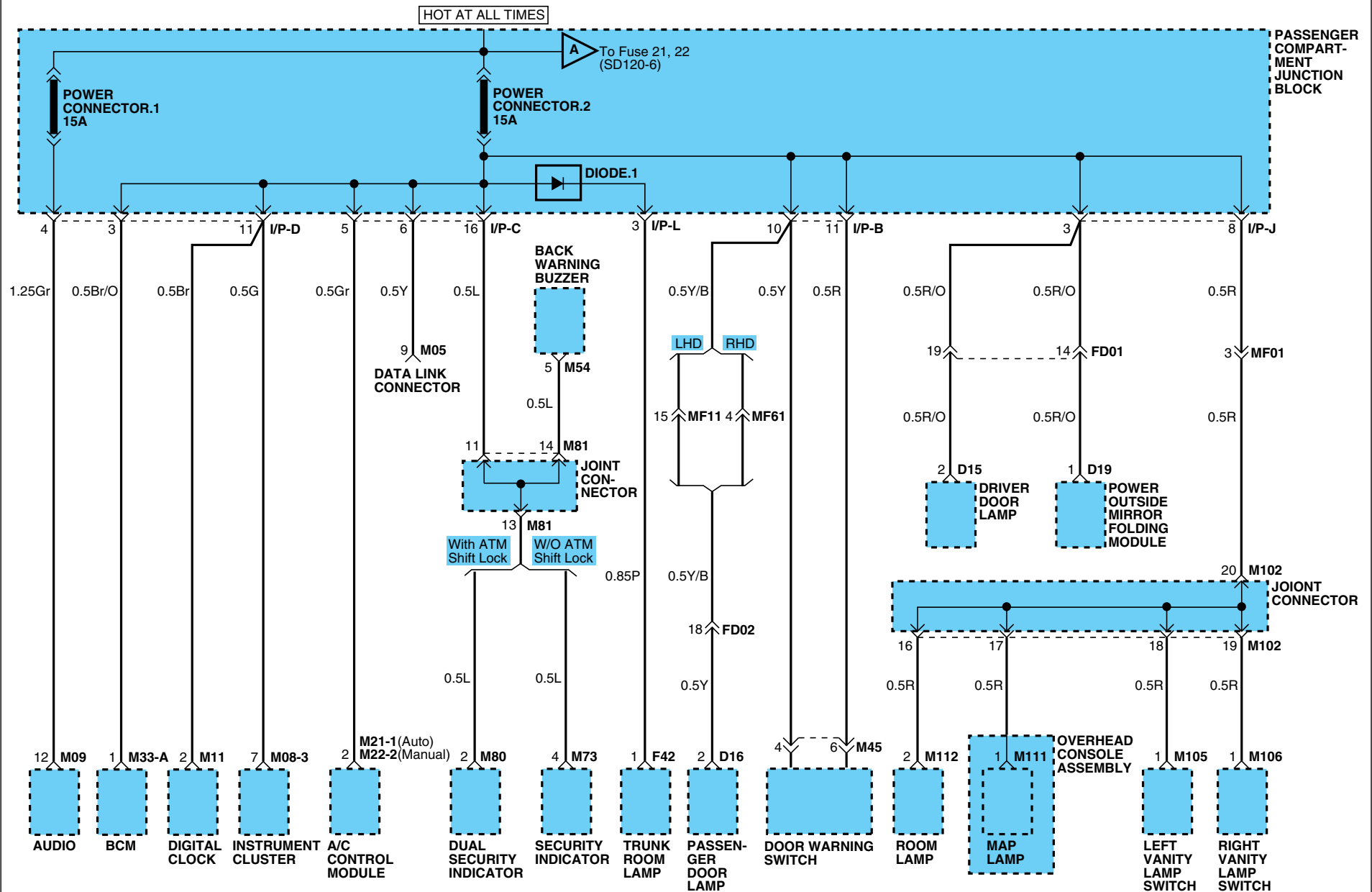

# PASSENGER COMPARTMENT FUSE DETAILS

## PASSENGER COMPARTMENT FUSE DETAILS (6)

SD120-6

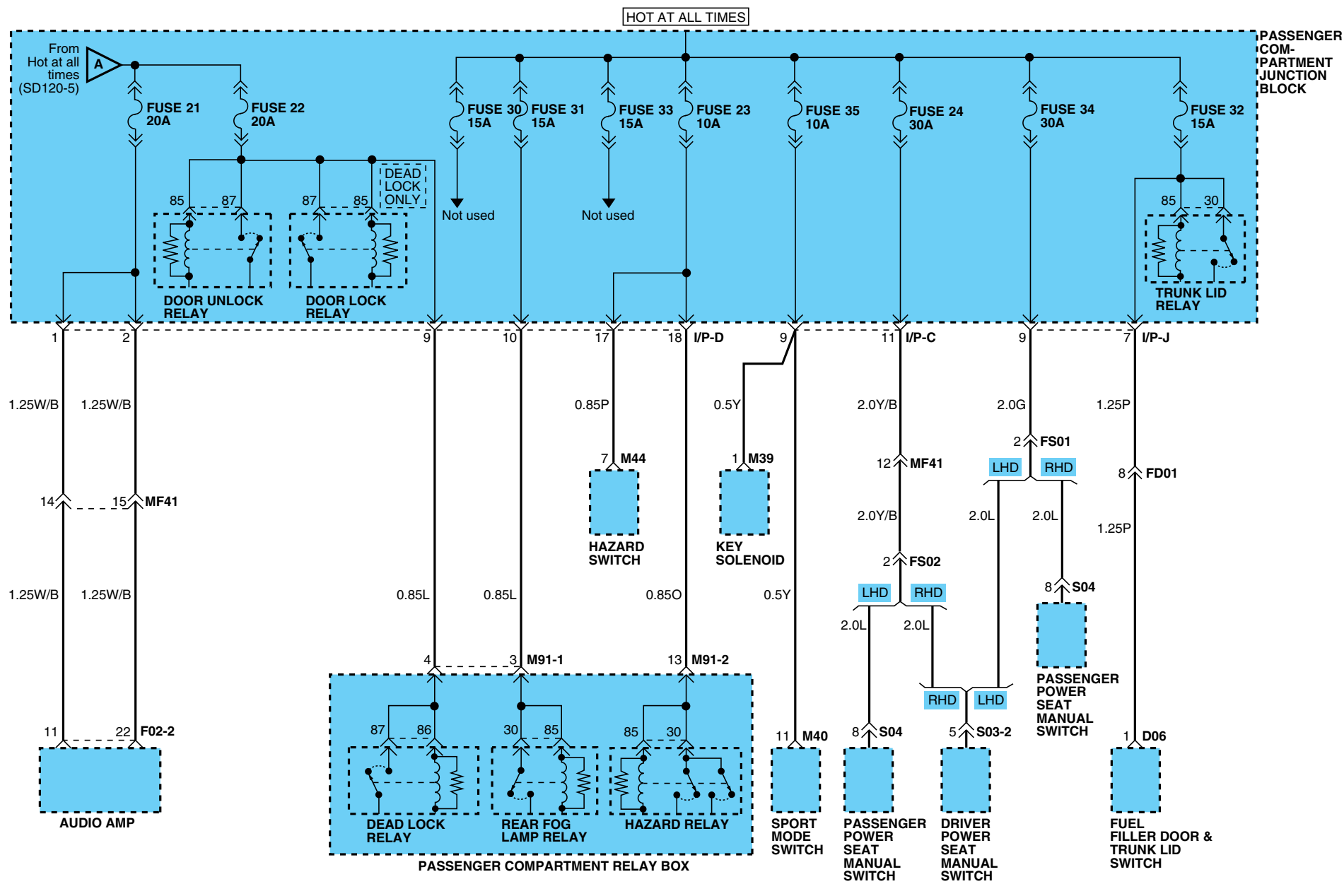

GROUND DISTRIBUTION (1)

SD130-1

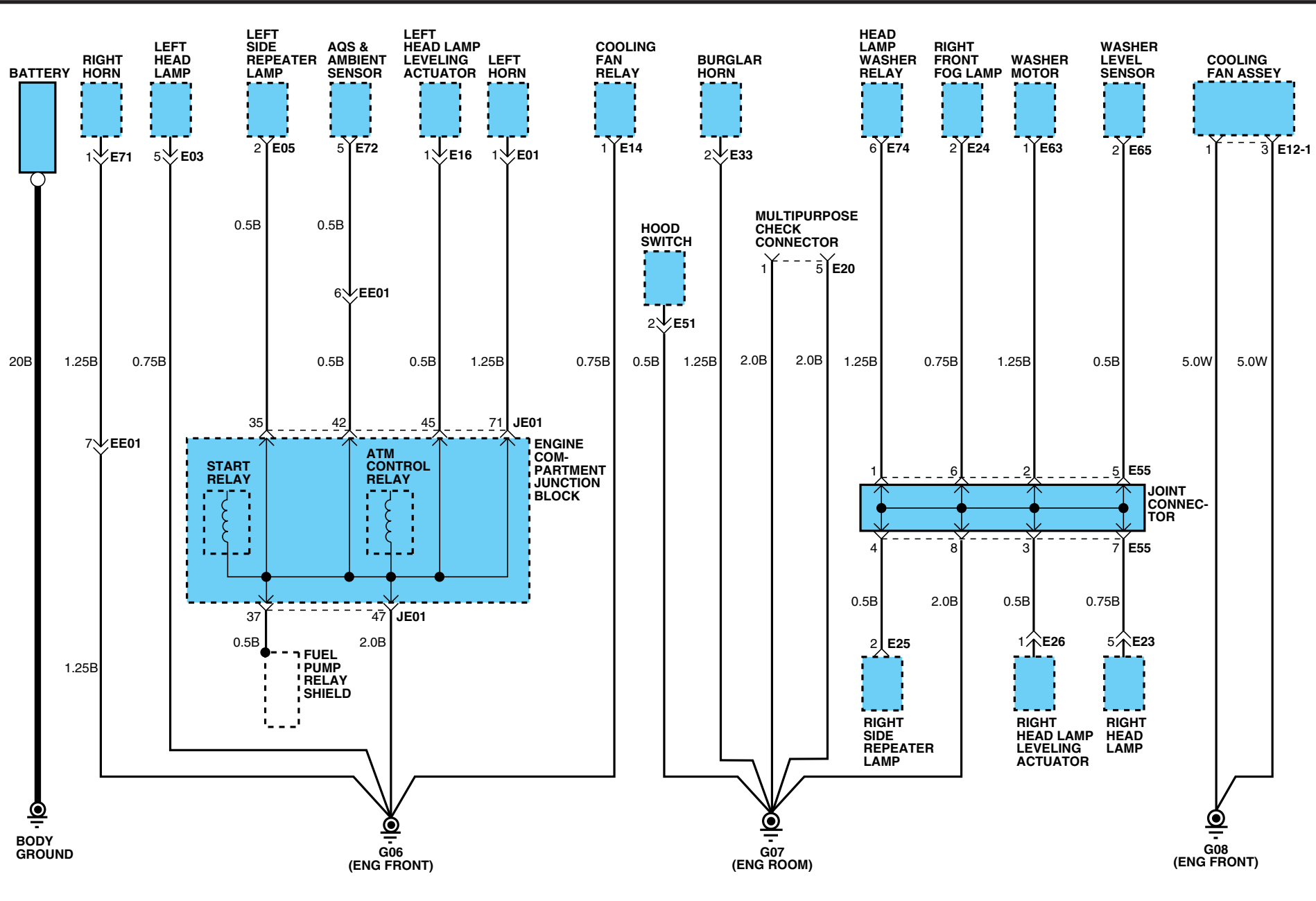

# GROUND DISTRIBUTION

## GROUND DISTRIBUTION (2)

SD130-2

### GASOLINE

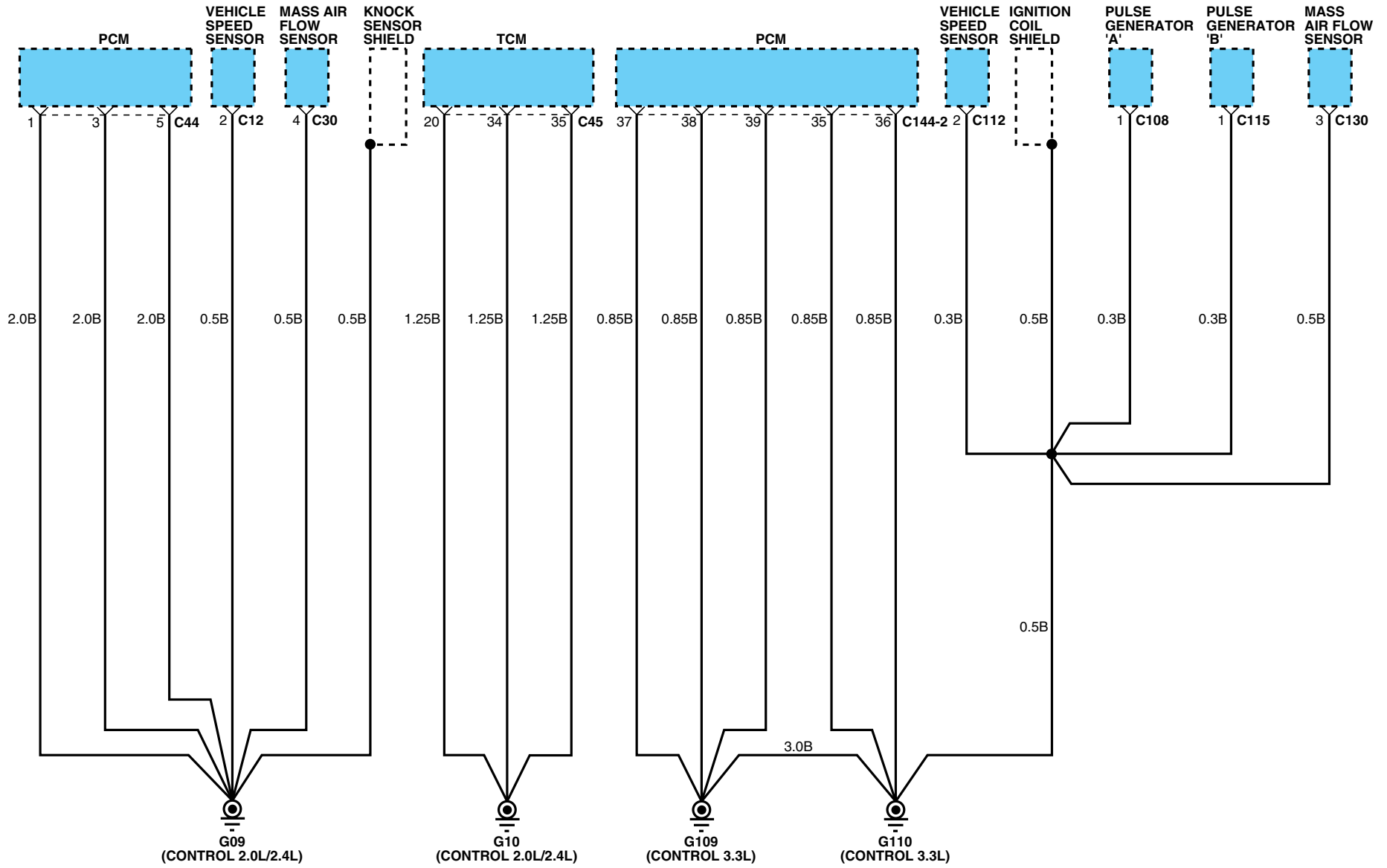

# GROUND DISTRIBUTION

## GROUND DISTRIBUTION (3)

SD130-3

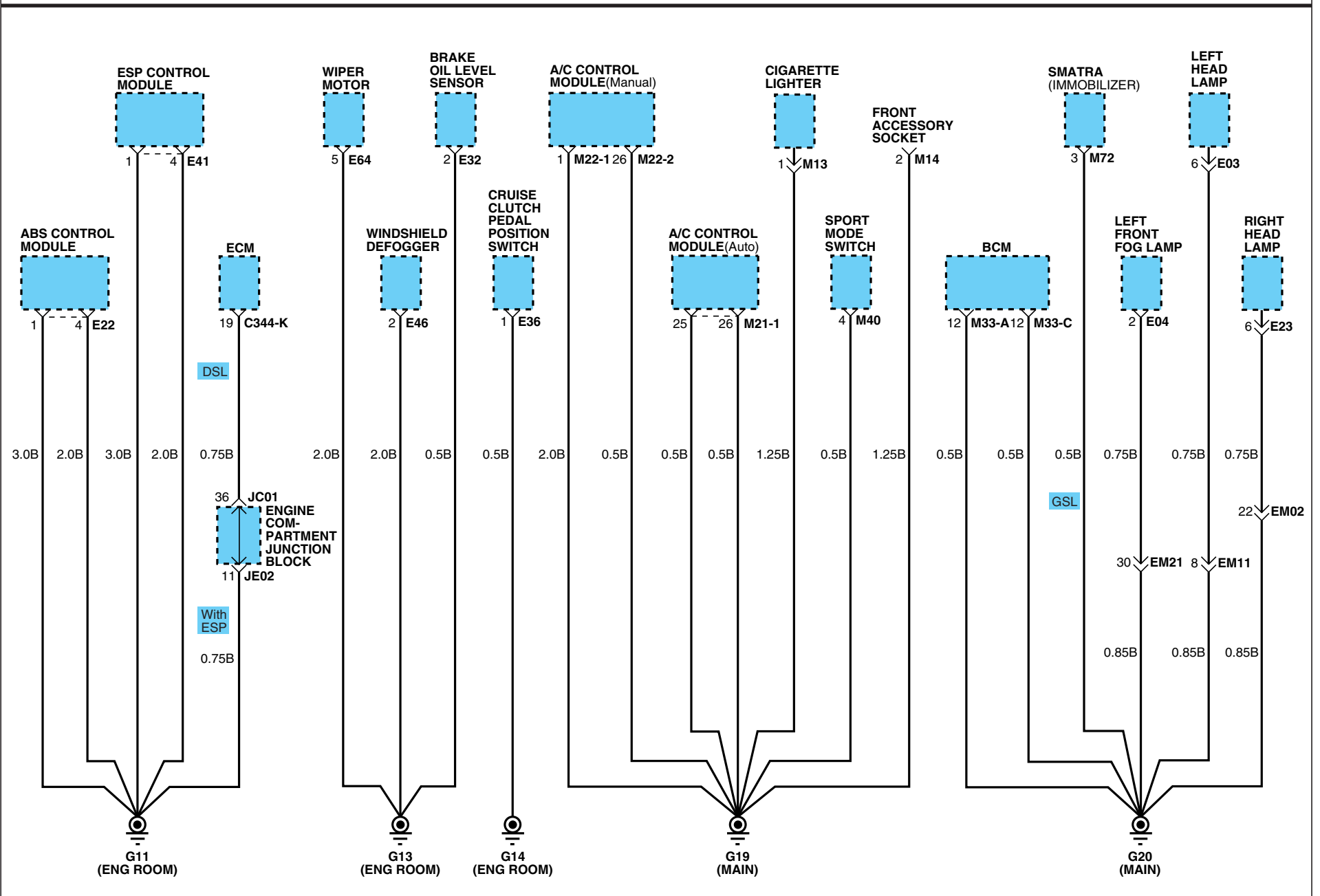





# GROUND DISTRIBUTION

## GROUND DISTRIBUTION (5)

SD130-5

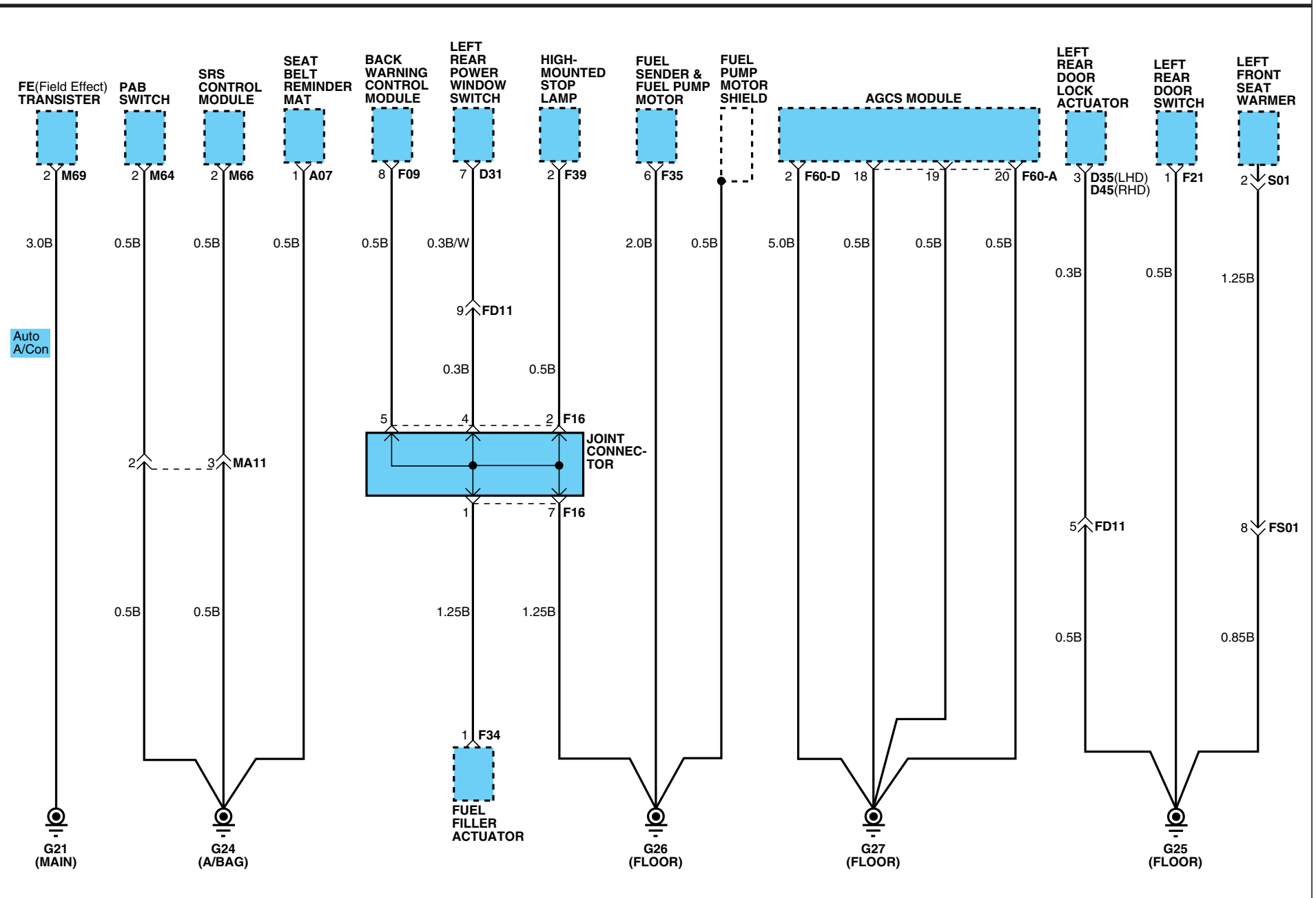



# GROUND DISTRIBUTION

## GROUND DISTRIBUTION (7)

SD130-7

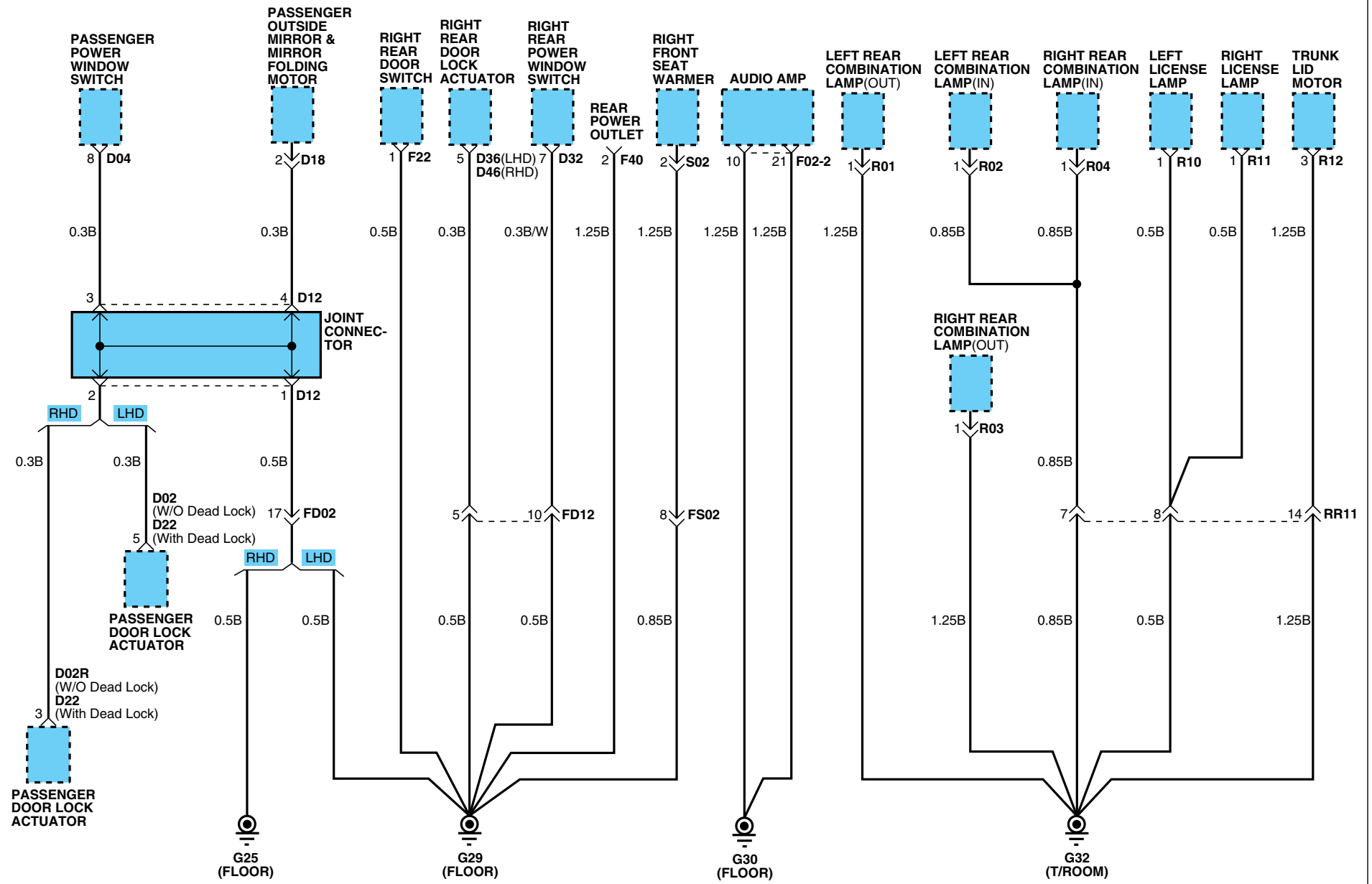

# GROUND DISTRIBUTION

## GROUND DISTRIBUTION (8)

SD130-8

### DIESEL

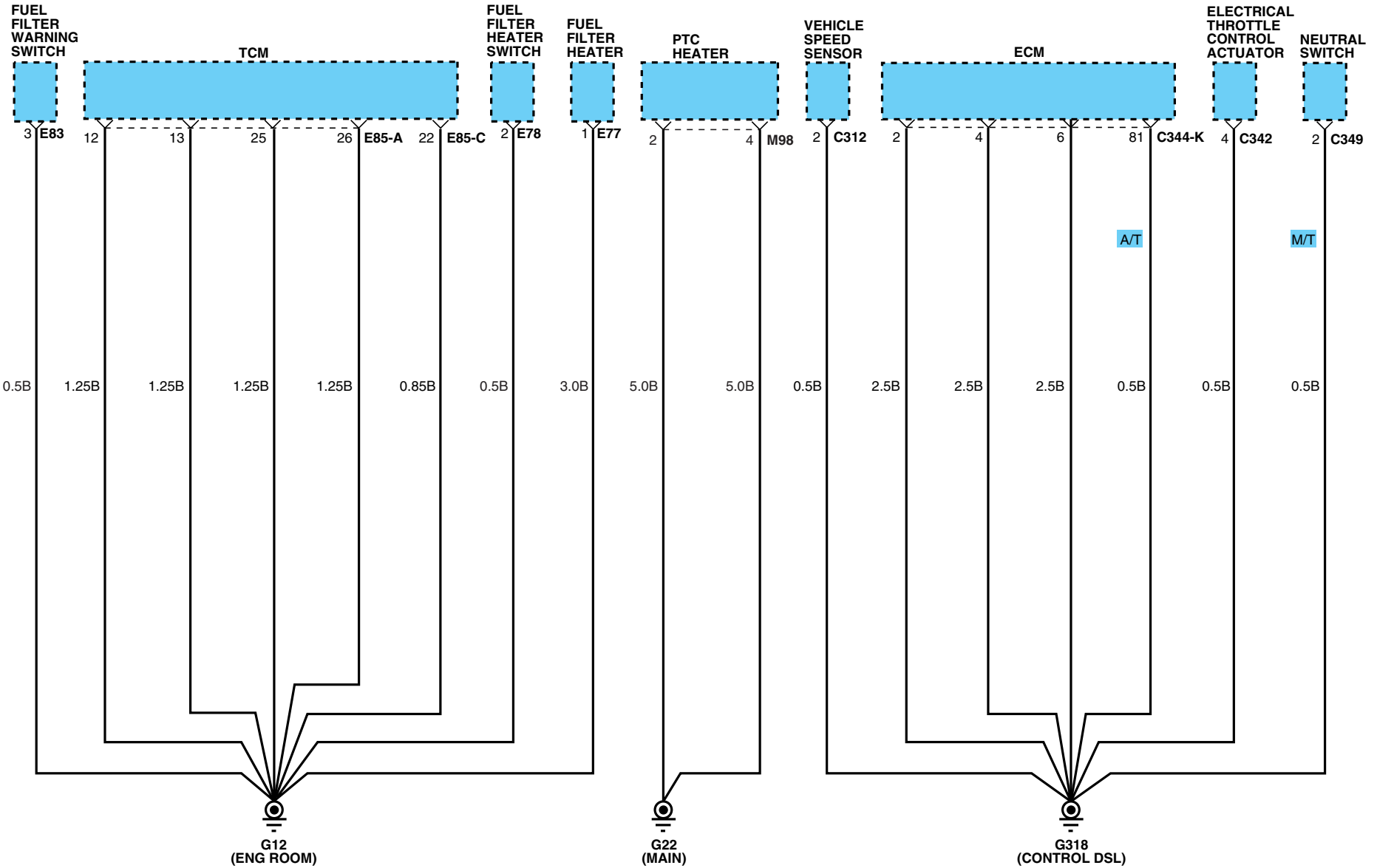

DATA LINK DETAILS (1)

SD200-1

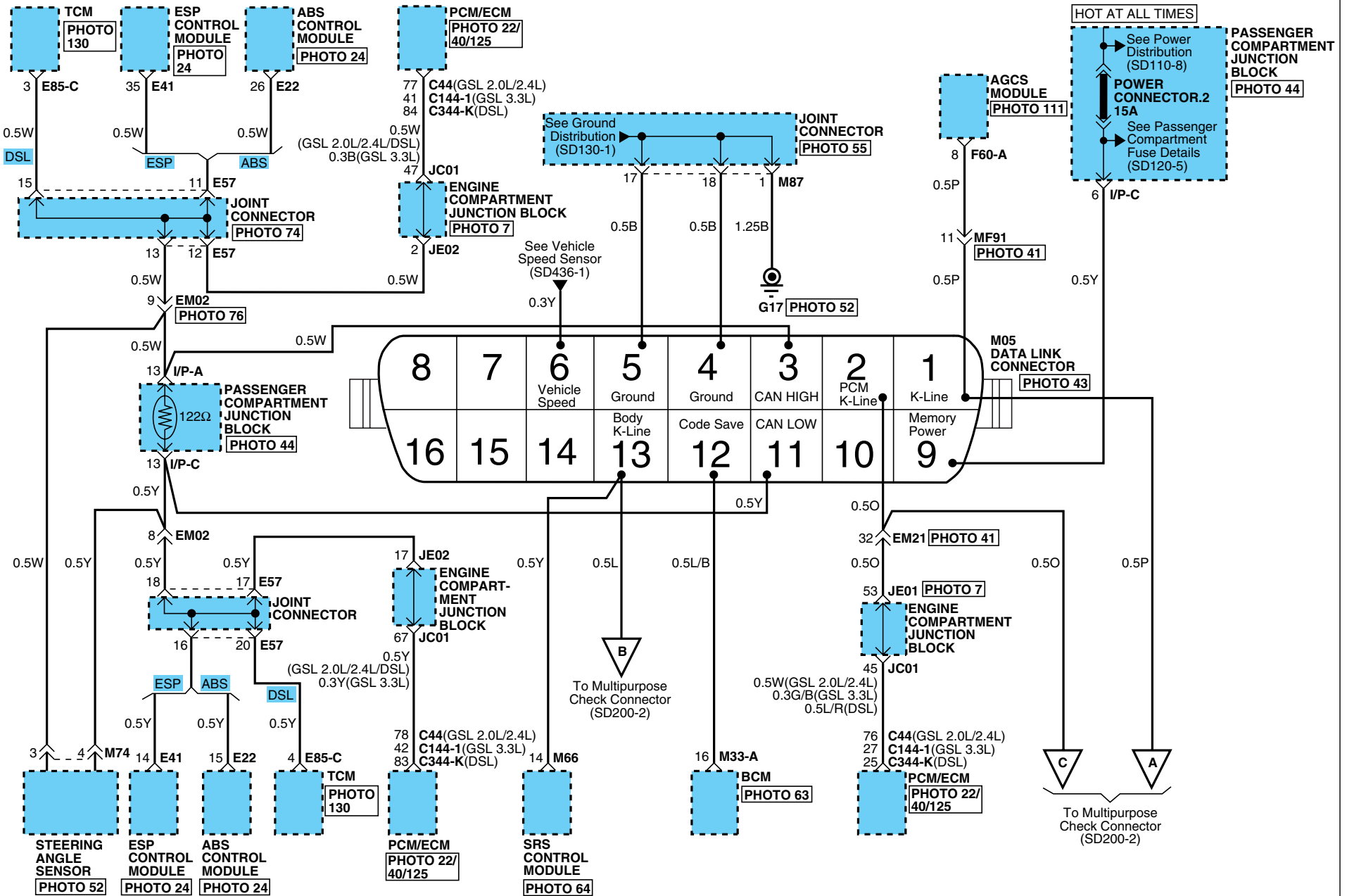

# DATA LINK DETAILS

## DATA LINK DETAILS (2)

SD200-2

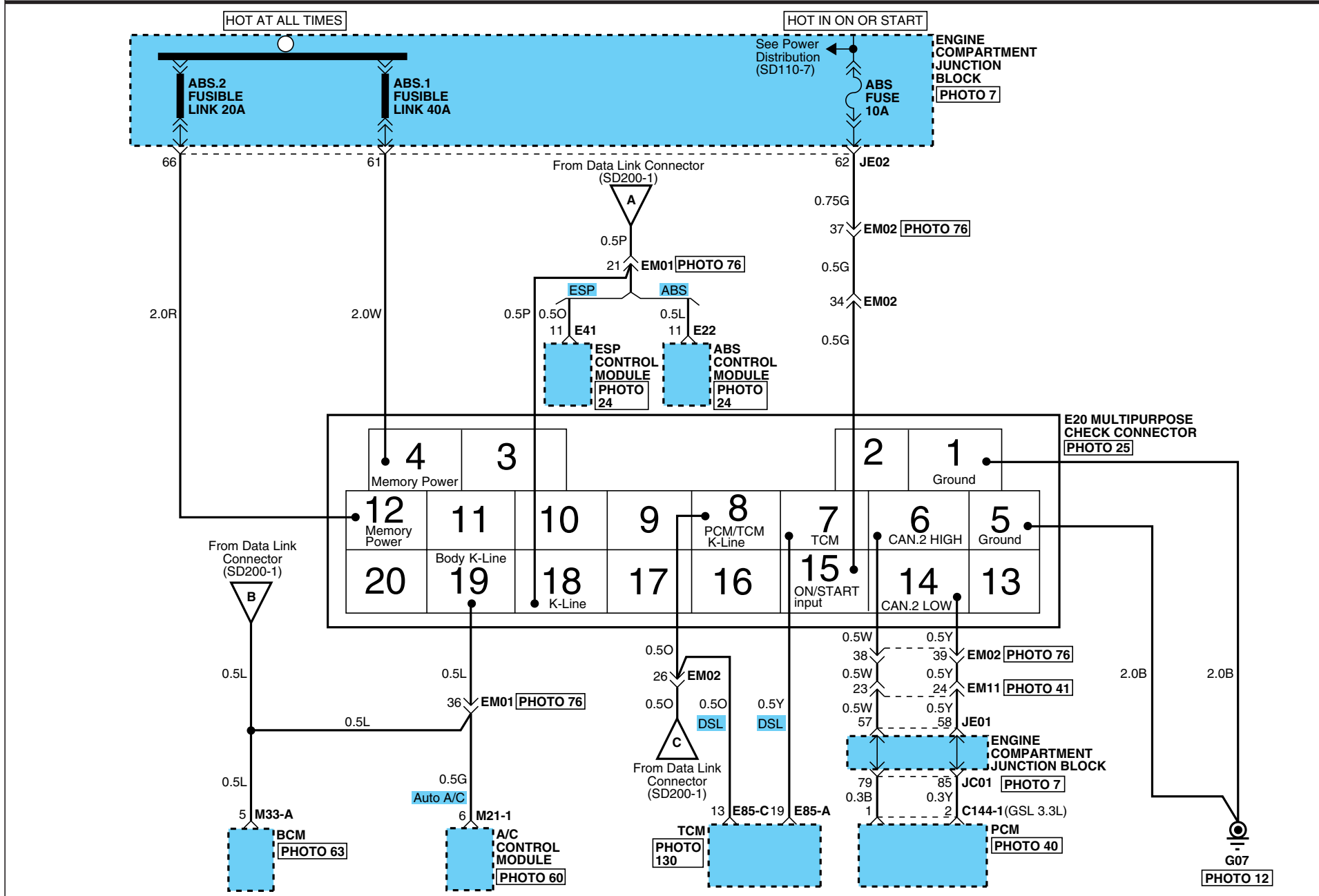

# DATA LINK DETAILS

## DATA LINK DETAILS (3)

SD200-3

**E20**

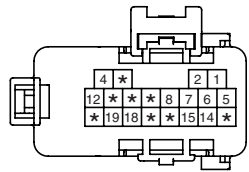

KET\_DIAG\_20F\_B\_BRK\_A

**E22**

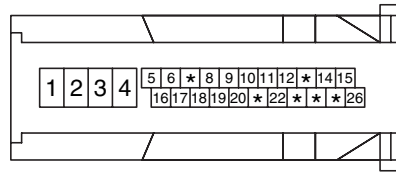

BOS\_ABS\_26F\_B\_L

**E41**

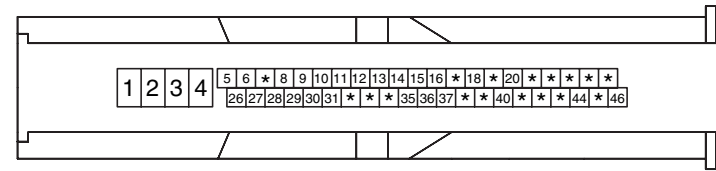

BOS\_ESP\_46F\_B\_L

**F60-A**

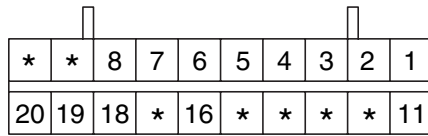

AMP\_040M2\_20F\_B

**M05**

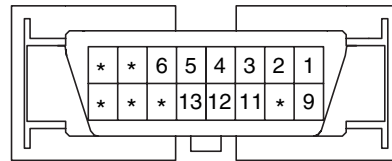

MLX\_OBDII\_16F\_B\_SIN

**M21-1**

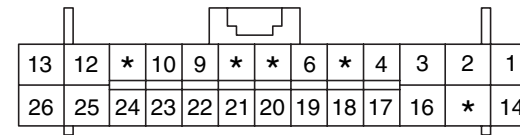

AMP\_0407\_26F\_W

**BLANK**

**M33-A**

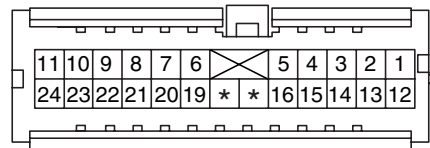

AMP\_040III\_24F\_W

**M66**

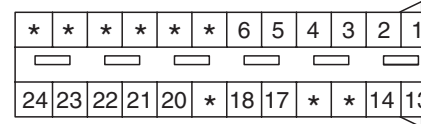

AMP\_ABG\_24F\_B\_ECU

**M74**

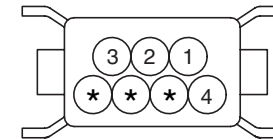

BSH\_040\_07F\_B



**DATA LINK DETAILS**

**DATA LINK DETAILS (4)**

**SD200-4**

**MEMO**

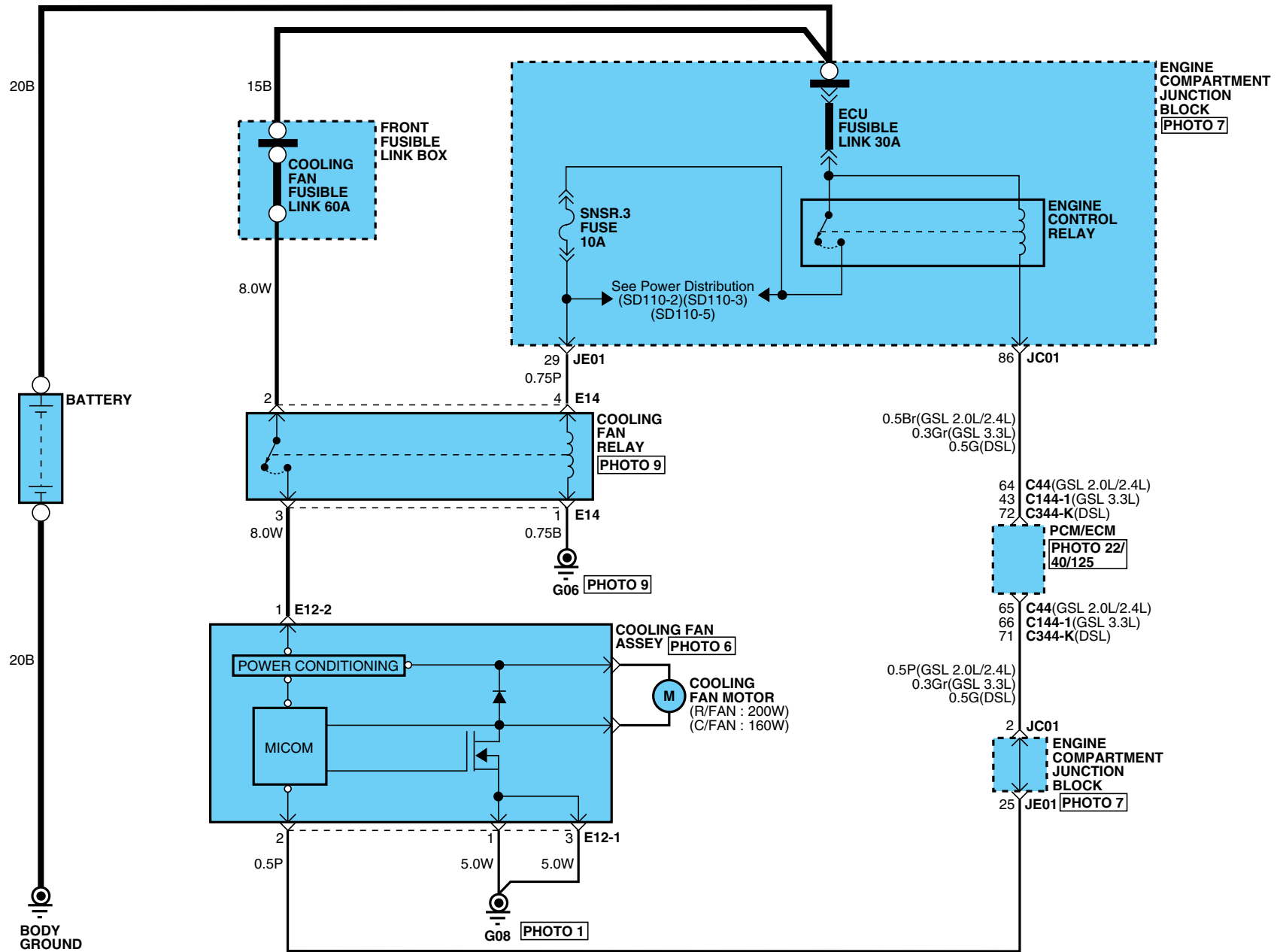

**COOLING SYSTEM**

**COOLING SYSTEM (2)**

**SD253-2**

**C44**

94	93	92	*	90	89	*	87	86	85	84	83	82	81	80	79	78	77	76	75	74	73	6	5
72	71	70	69	*	67	66	65	64	63	62	61	60	59	58	57	56	55	*	53	52	51	4	3
*	*	48	47	*	*	*	*	42	41	40	39	38	37	*	35	*	*	*	*	30	29	2	1
28	27	26	25	24	23	22	21	20	19	18	17	16	15	14	13	12	11	10	9	8	7		

SIE\_PCU\_94F\_B

**C144-1**

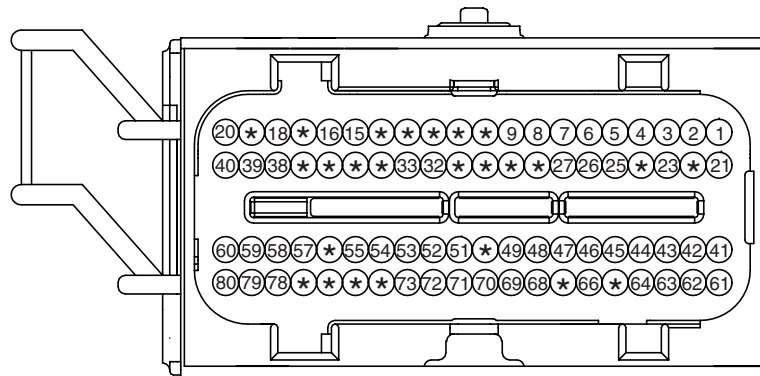

PKD\_ECU\_80F\_B\_1

**C344-K**

94	93	92	91	90	89	*	87	86	*	84	83	*	81	80	79	*	77	*	75	*	*	6	5
72	71	70	69	68	*	*	65	64	*	*	*	*	*	57	56	*	54	*	*	51	4	3	
*	49	48	47	46	45	44	*	42	*	40	*	38	37	36	35	34	33	32	31	30	29	2	1
28	27	26	25	24	*	22	*	*	19	*	*	16	15	14	13	12	11	10	9	8	*		

AMP\_ECU\_94F\_B

**E12-1**

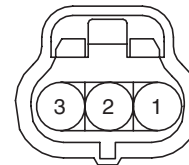

KET\_3118\_03F\_B

**E12-2**



KET\_3121IWP\_01F\_B

**E14**

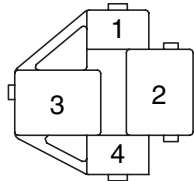

KET\_3725\_04F\_B

**BLANK**

**BLANK**

**BLANK**

MFI CONTROL SYSTEM (GSL 2.0L/2.4L) (1)

SD313-1

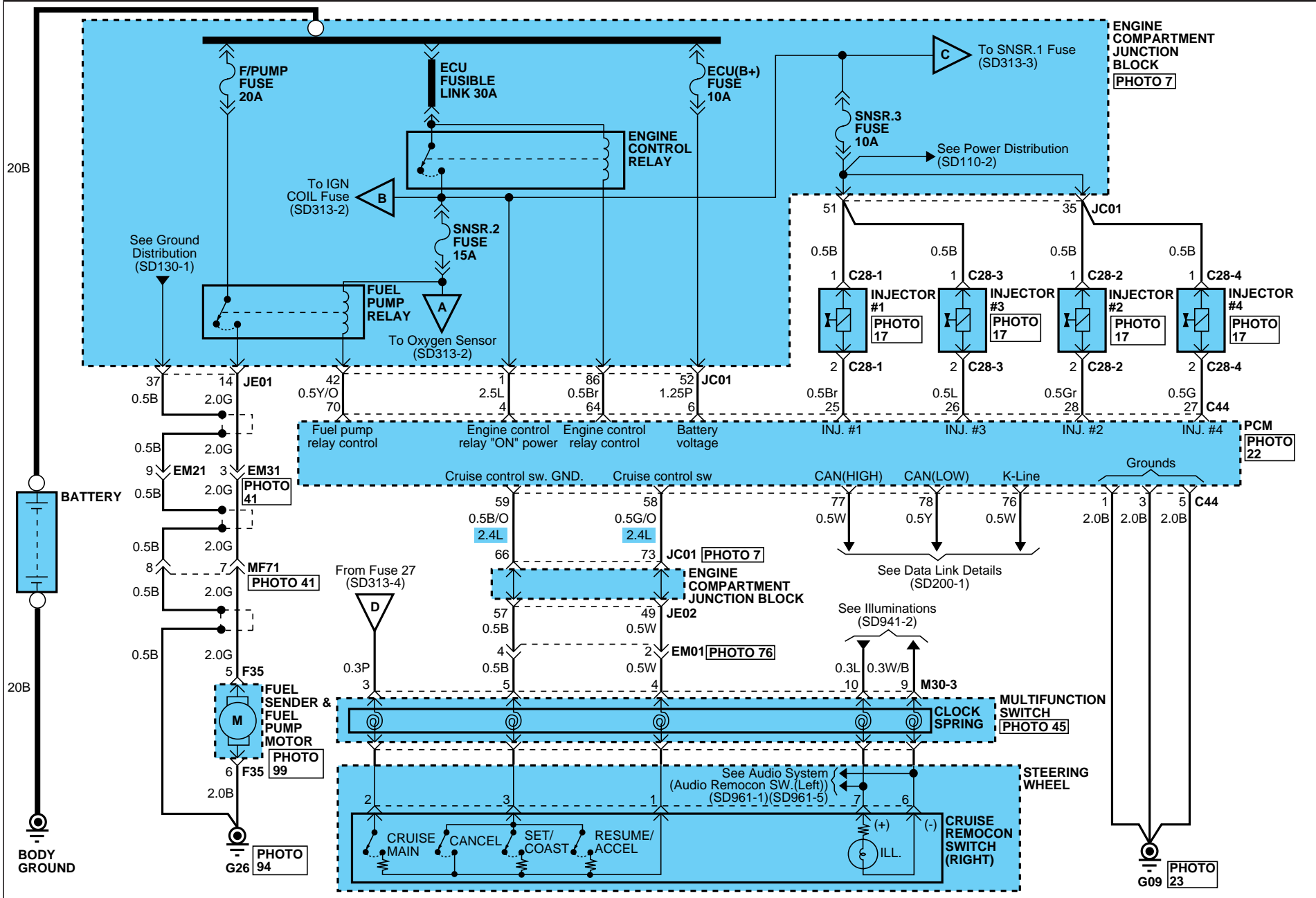

# MFI CONTROL SYSTEM

## MFI CONTROL SYSTEM (GSL 2.0L/2.4L) (2)

SD313-2

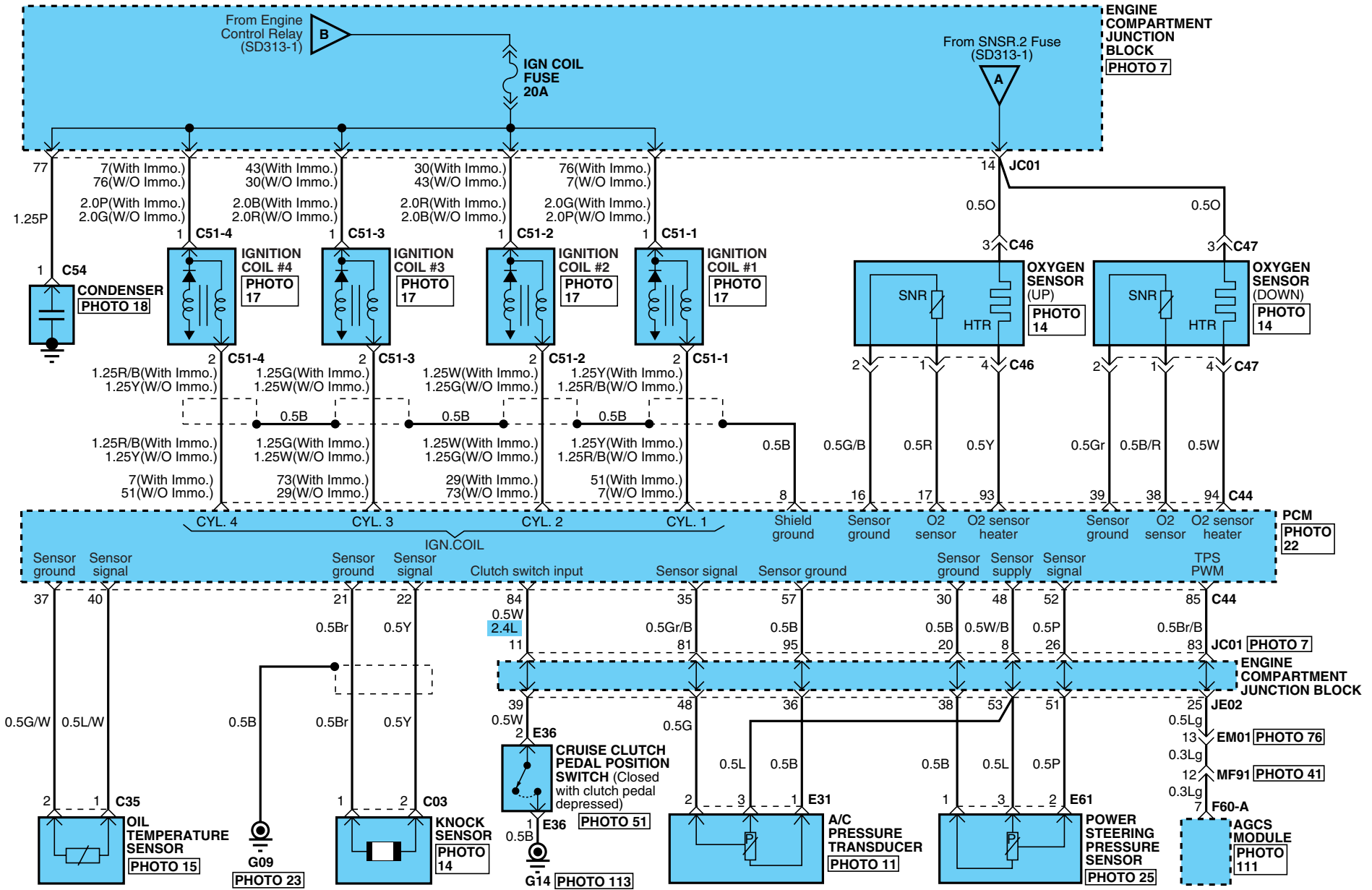

# MFI CONTROL SYSTEM

## MFI CONTROL SYSTEM (GSL 2.0L/2.4L) (3)

SD313-3

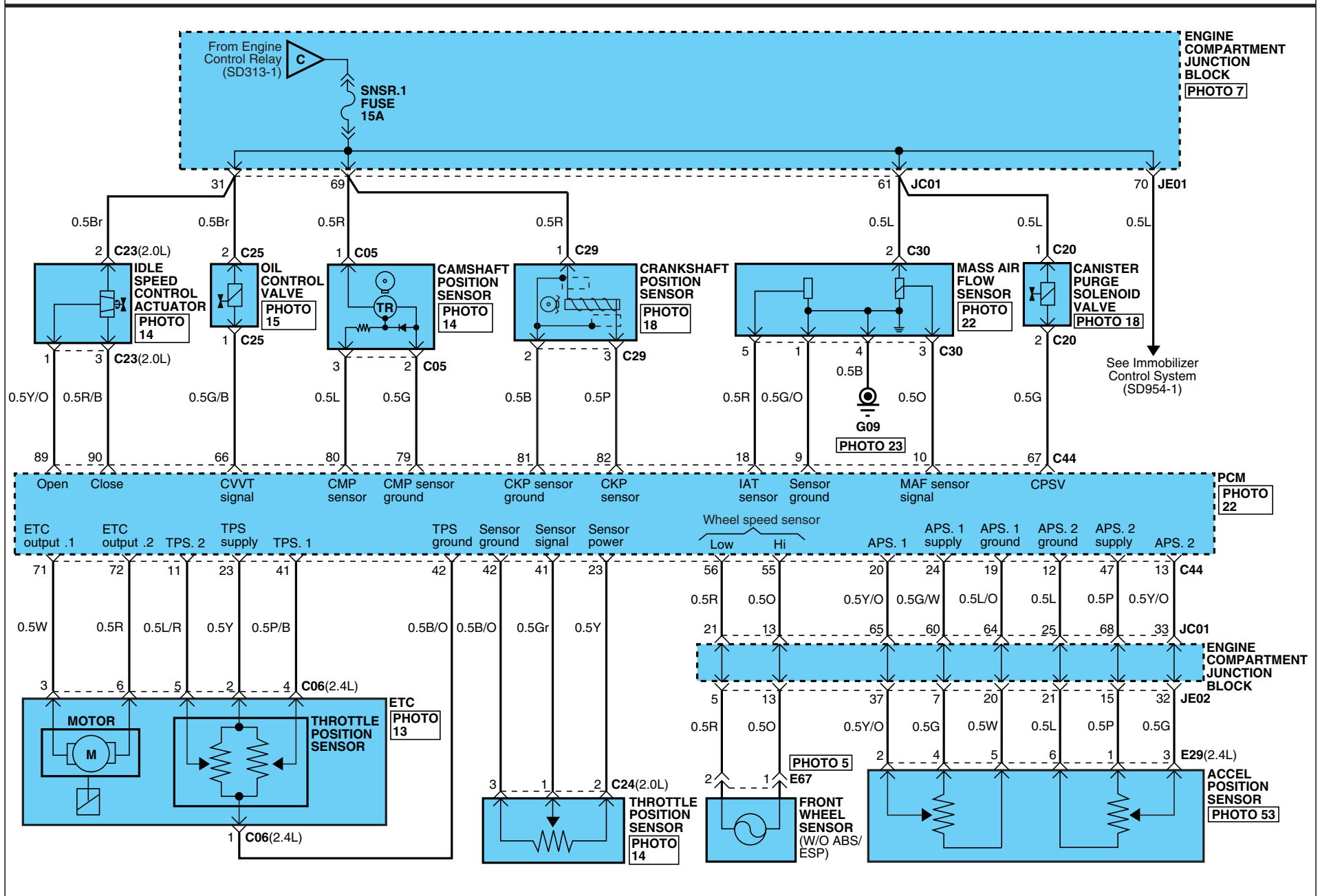





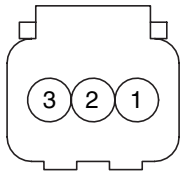
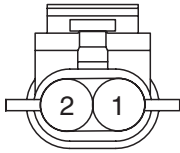
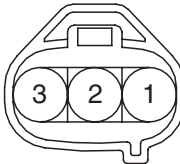
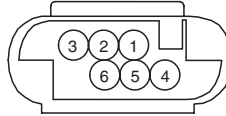
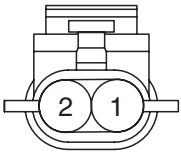
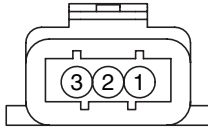
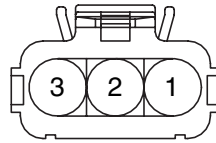

**MFI CONTROL SYSTEM**

**MFI CONTROL SYSTEM (GSL 2.0L/2.4L) (5)**

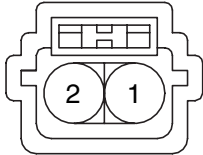
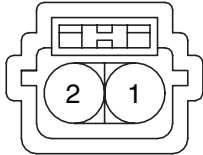
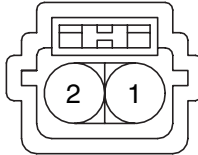
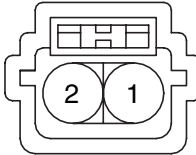
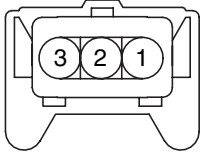
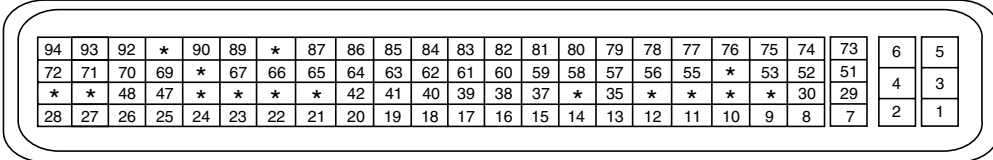
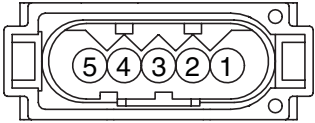
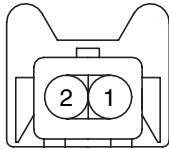
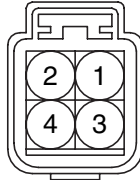
**SD313-5**



<p><b>C01</b></p>  <p>KUM_WTS_03F_B</p>	<p><b>C03</b></p>  <p>PKD_150WP_02F_GR</p>	<p><b>C05</b></p>  <p>SUM_090IWP_03F_GR_R</p>	<p><b>C06</b></p>  <p>AMP_MOSWP_06F_B_1</p>																																																																																																
<p><b>C20</b></p>  <p>PKD_MP150_02F_B</p>	<p><b>C23</b></p>  <p>BSH_ISA_03F_Gr</p>	<p><b>C24</b></p>  <p>AMP_JPT_03F_B_BOSCH</p>	<p><b>C25</b></p>  <p>KET_090WP_02F_B_L</p>																																																																																																
<p><b>C28-1</b></p>  <p>KUM_NDWP_02F_B</p>	<p><b>C28-2</b></p>  <p>KUM_NDWP_02F_B</p>	<p><b>C28-3</b></p>  <p>KUM_NDWP_02F_B</p>	<p><b>C28-4</b></p>  <p>KUM_NDWP_02F_B</p>																																																																																																
<p><b>C29</b></p>  <p>AMP_JPT_03F_B_S2</p>	<p><b>C44</b></p>  <table border="1" data-bbox="869 1082 1787 1171"> <tr> <td>94</td><td>93</td><td>92</td><td>*</td><td>90</td><td>89</td><td>*</td><td>87</td><td>86</td><td>85</td><td>84</td><td>83</td><td>82</td><td>81</td><td>80</td><td>79</td><td>78</td><td>77</td><td>76</td><td>75</td><td>74</td><td>73</td><td>6</td><td>5</td> </tr> <tr> <td>72</td><td>71</td><td>70</td><td>69</td><td>*</td><td>67</td><td>66</td><td>65</td><td>64</td><td>63</td><td>62</td><td>61</td><td>60</td><td>59</td><td>58</td><td>57</td><td>56</td><td>55</td><td>*</td><td>53</td><td>52</td><td>51</td><td>4</td><td>3</td> </tr> <tr> <td>*</td><td>*</td><td>48</td><td>47</td><td>*</td><td>*</td><td>*</td><td>*</td><td>42</td><td>41</td><td>40</td><td>39</td><td>38</td><td>37</td><td>*</td><td>35</td><td>*</td><td>*</td><td>*</td><td>*</td><td>30</td><td>29</td><td>2</td><td>1</td> </tr> <tr> <td>28</td><td>27</td><td>26</td><td>25</td><td>24</td><td>23</td><td>22</td><td>21</td><td>20</td><td>19</td><td>18</td><td>17</td><td>16</td><td>15</td><td>14</td><td>13</td><td>12</td><td>11</td><td>10</td><td>9</td><td>8</td><td>7</td><td></td><td></td> </tr> </table> <p>SIE_PCU_94F_B</p>			94	93	92	*	90	89	*	87	86	85	84	83	82	81	80	79	78	77	76	75	74	73	6	5	72	71	70	69	*	67	66	65	64	63	62	61	60	59	58	57	56	55	*	53	52	51	4	3	*	*	48	47	*	*	*	*	42	41	40	39	38	37	*	35	*	*	*	*	30	29	2	1	28	27	26	25	24	23	22	21	20	19	18	17	16	15	14	13	12	11	10	9	8	7		
94	93	92	*	90	89	*	87	86	85	84	83	82	81	80	79	78	77	76	75	74	73	6	5																																																																												
72	71	70	69	*	67	66	65	64	63	62	61	60	59	58	57	56	55	*	53	52	51	4	3																																																																												
*	*	48	47	*	*	*	*	42	41	40	39	38	37	*	35	*	*	*	*	30	29	2	1																																																																												
28	27	26	25	24	23	22	21	20	19	18	17	16	15	14	13	12	11	10	9	8	7																																																																														
<p><b>C30</b></p>  <p>KST_SLK2.8_05F_B_CODEB</p>	<p><b>C35</b></p>  <p>AMP_JPT_02F_B_CLIP</p>	<p><b>C46</b></p>  <p>KUM_NMWP_04F_B</p>	<p><b>C47</b></p>  <p>KET_090IWP_04F_B</p>																																																																																																



**MFI CONTROL SYSTEM**

**MFI CONTROL SYSTEM (GSL 2.0L/2.4L) (6)**

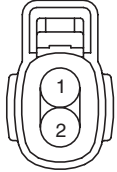
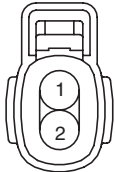
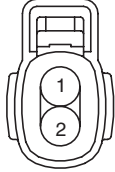
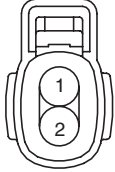
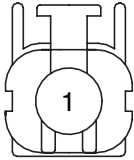
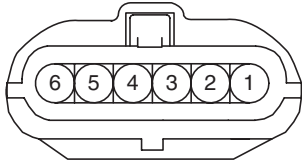
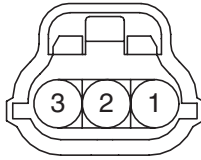
**SD313-6**

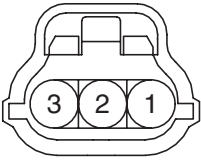
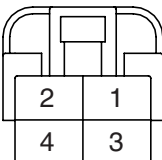
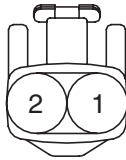
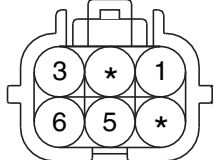
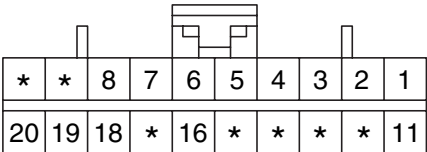
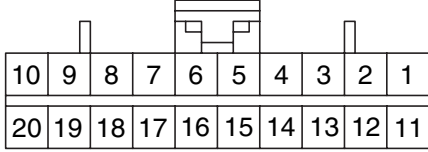
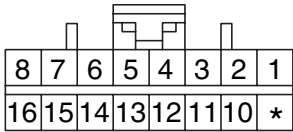
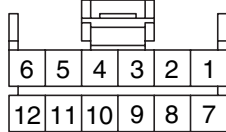
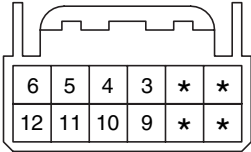
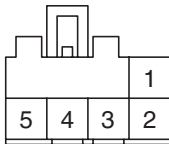
<p><b>C51-1</b></p>  <p>KET_090IWP_02F_Gr_VER</p>	<p><b>C51-2</b></p>  <p>KET_090IWP_02F_Gr_VER</p>	<p><b>C51-3</b></p>  <p>KET_090IWP_02F_Gr_VER</p>	<p><b>C51-4</b></p>  <p>KET_090IWP_02F_Gr_VER</p>
<p><b>C54</b></p>  <p>KET_58X_01F_B</p>	<p><b>E29</b></p>  <p>AMP_070WP_06F_W</p>	<p><b>E31</b></p>  <p>YAZ_040WP_03F_B</p>	<p><b>E36</b></p>  <p>KET_250DL_02F_W</p>
<p><b>E61</b></p>  <p>YAZ_040WP_03F_B</p>	<p><b>E62</b></p>  <p>KET_250DL_04F_W</p>	<p><b>E67</b></p>  <p>KET_090IWP_02F_B</p>	<p><b>F35</b></p>  <p>KET_SWP_06F_B</p>
<p><b>F60-A</b></p>  <p>AMP_040M2_20F_B</p>	<p><b>M08-1</b></p>  <p>AMP_040M2_20F_B</p>	<p><b>M08-2</b></p>  <p>AMP_040M2_16F_B</p>	<p><b>M08-3</b></p>  <p>AMP_040M1_12F_B</p>
<p><b>M30-3</b></p>  <p>AMP_025_12F_W</p>	<p><b>M72</b></p>  <p>KUM_CDR_05F_W</p>	<p><b>BLANK</b></p>	<p><b>BLANK</b></p>

# MFI CONTROL SYSTEM

## MFI CONTROL SYSTEM (GSL 3.3L) (1)

SD313-7

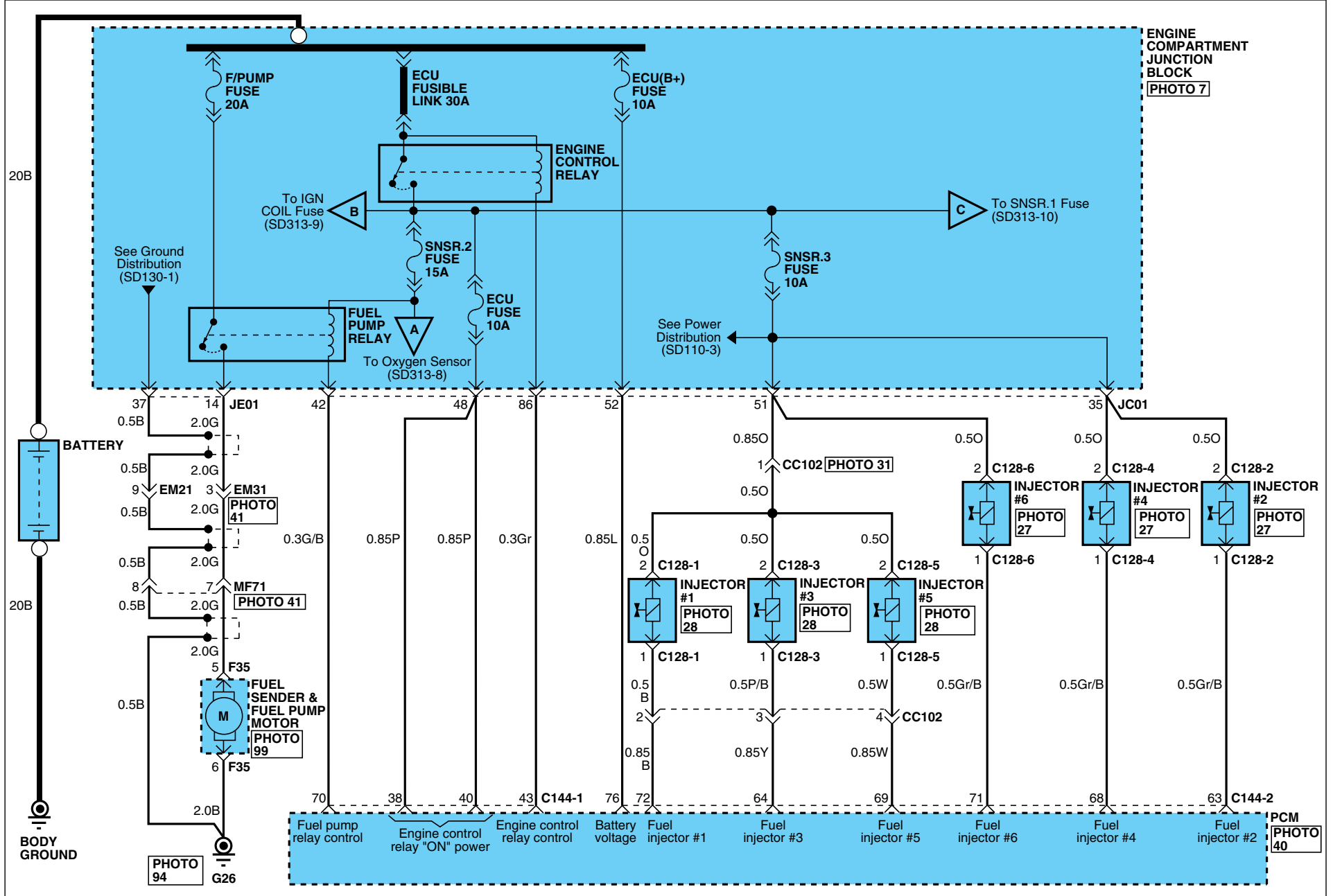

MFI CONTROL SYSTEM

MFI CONTROL SYSTEM (GSL 3.3L) (2)

SD313-8

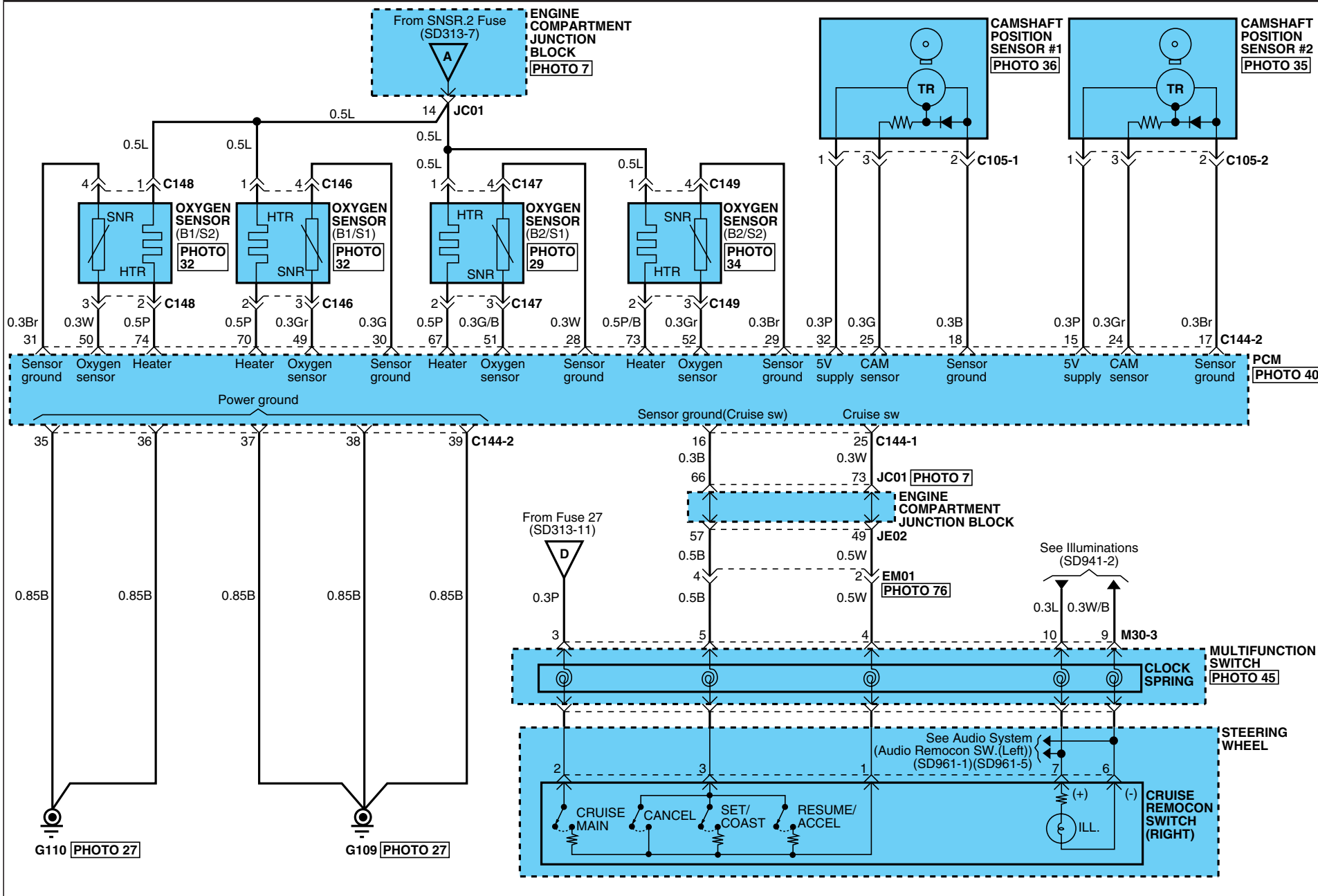

# MFI CONTROL SYSTEM

## MFI CONTROL SYSTEM (GSL 3.3L) (3)

SD313-9

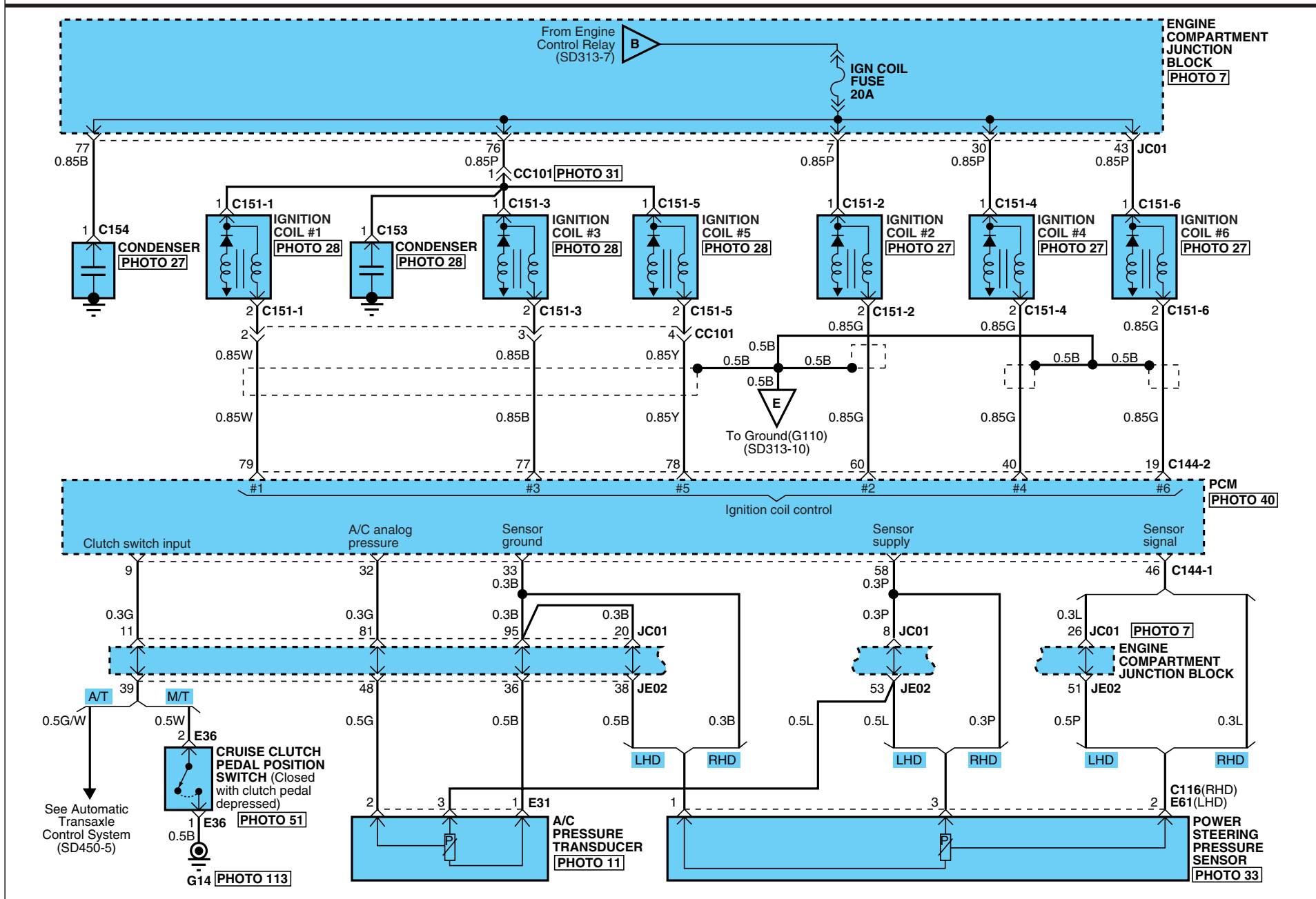

# MFI CONTROL SYSTEM

## MFI CONTROL SYSTEM (GSL 3.3L) (4)

SD313-10

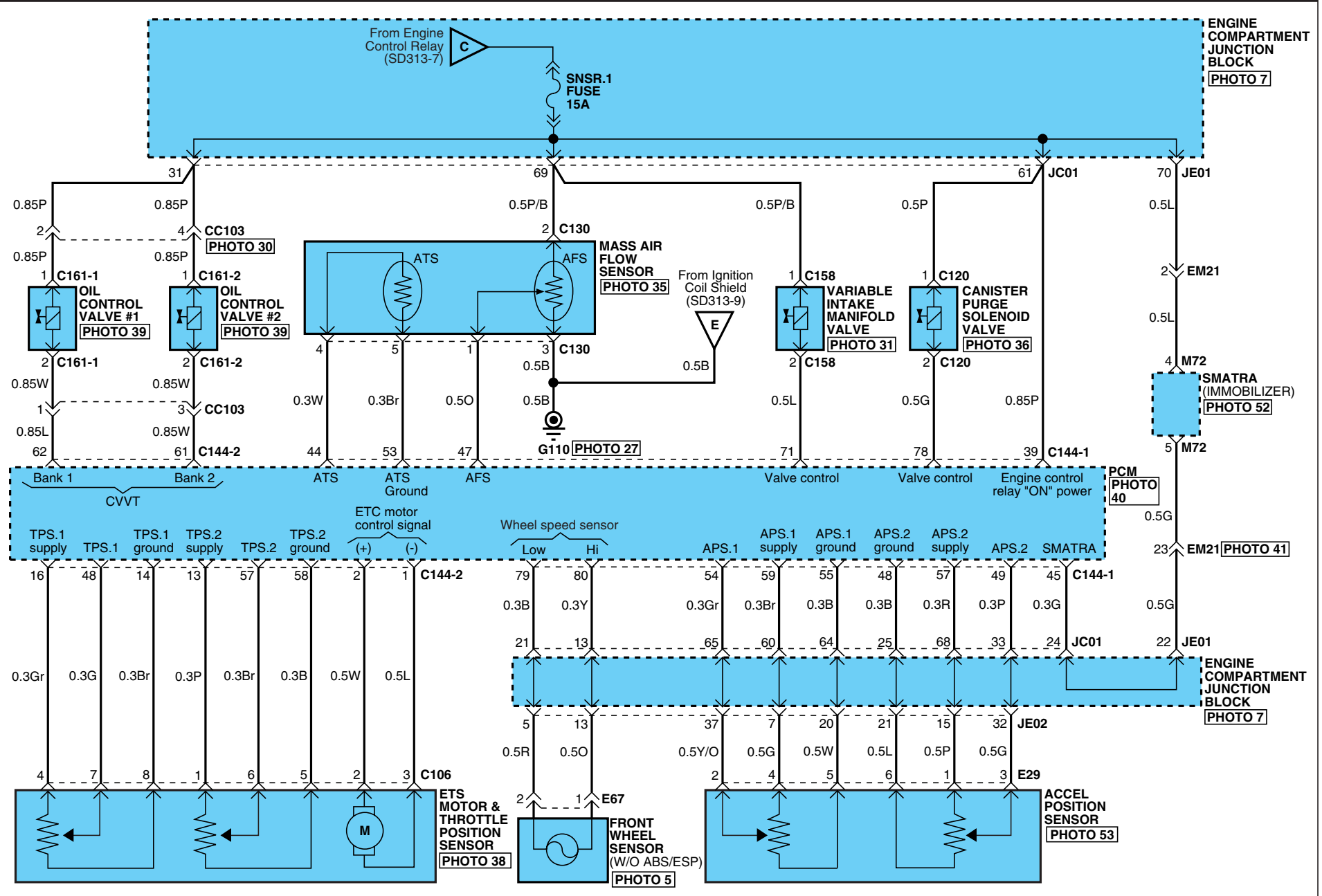

# MFI CONTROL SYSTEM

## MFI CONTROL SYSTEM (GSL 3.3L) (5)

SD313-11

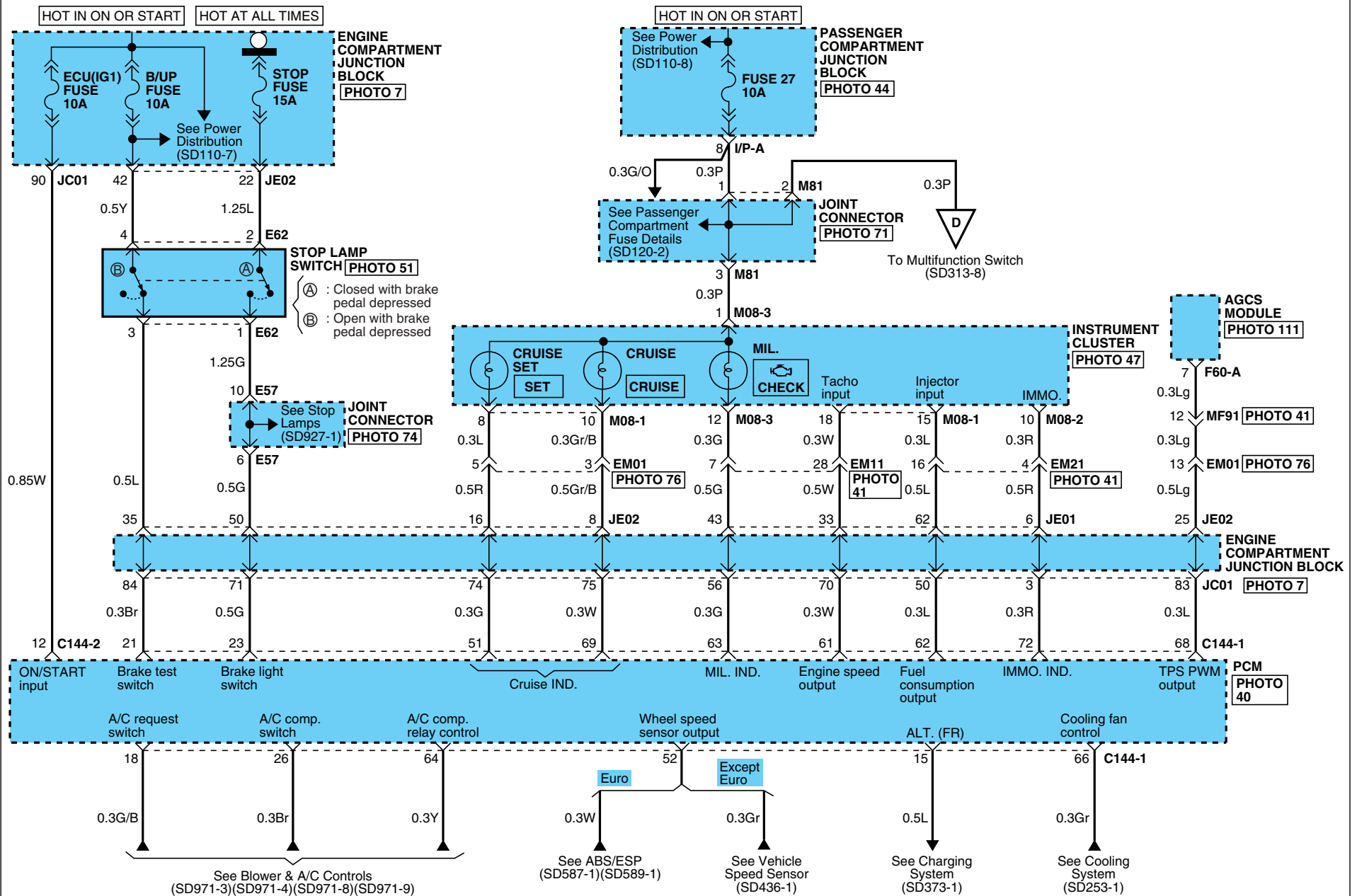

# MFI CONTROL SYSTEM

## MFI CONTROL SYSTEM (GSL 3.3L) (6)

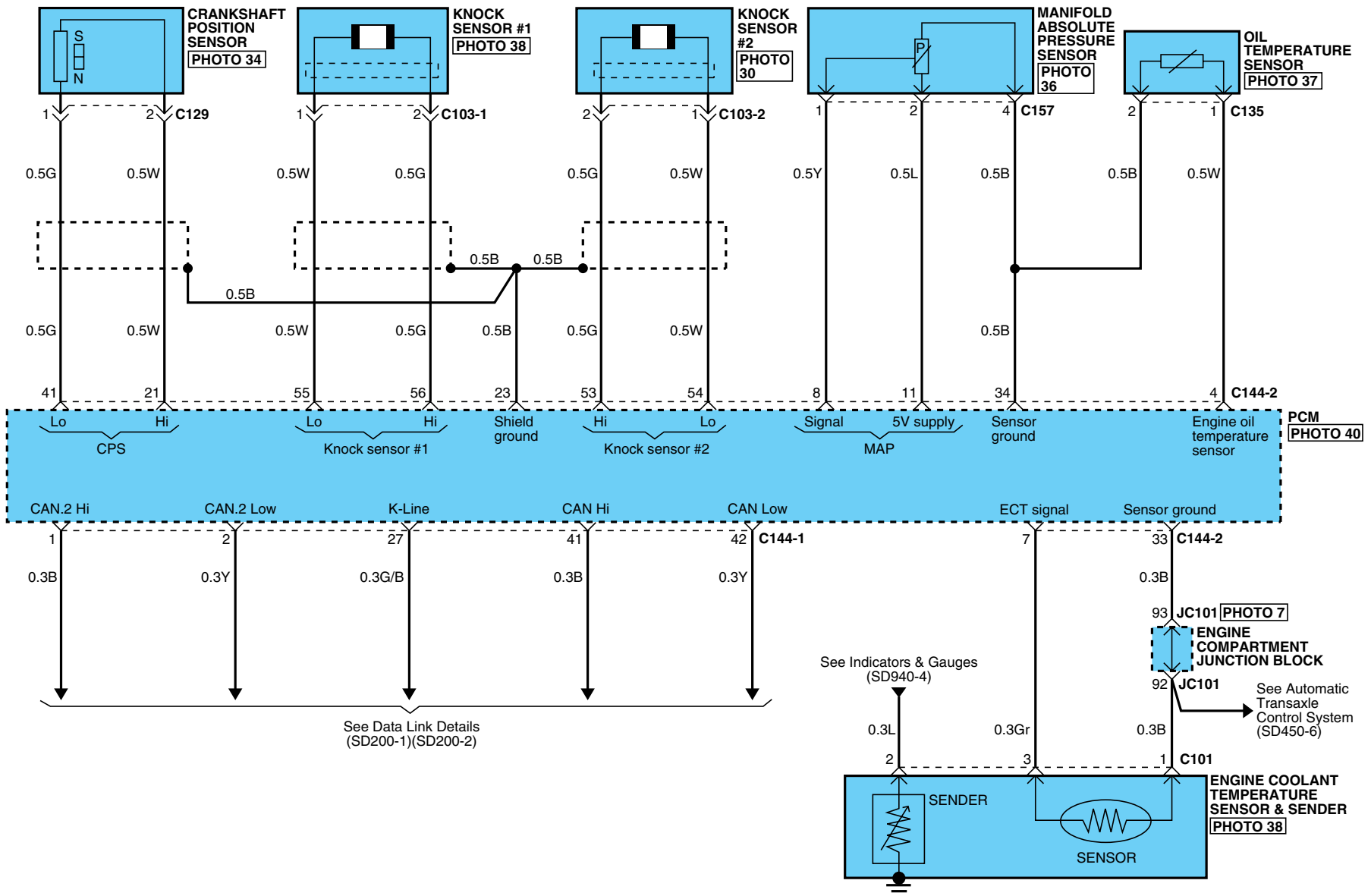

SD313-12



**MFI CONTROL SYSTEM**

**MFI CONTROL SYSTEM (GSL 3.3L) (7)**

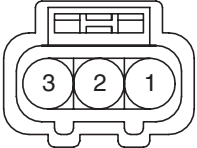
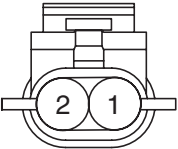
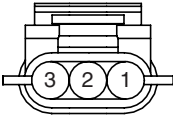
**SD313-13**

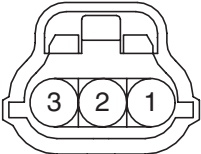
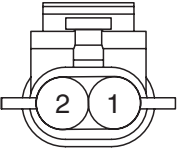
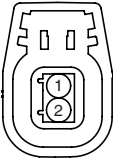
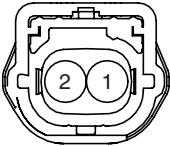
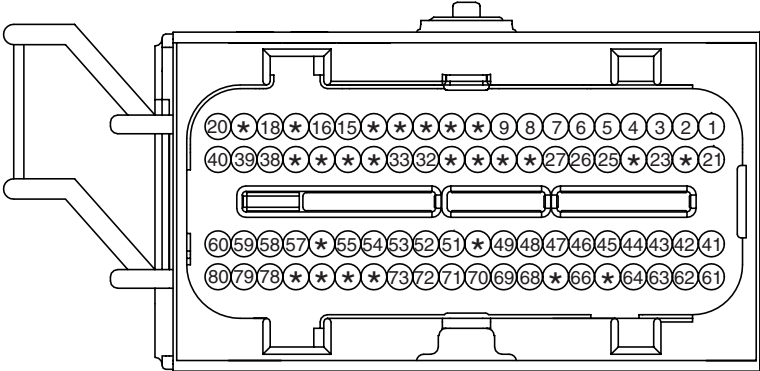
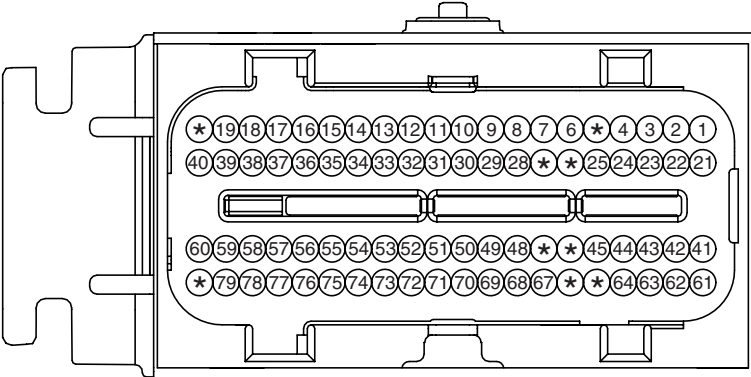
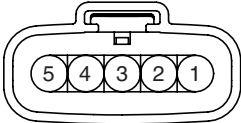
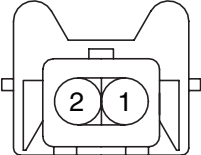
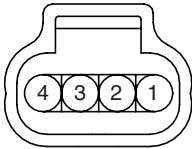
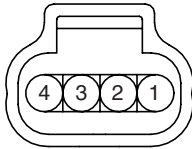

<p><b>C101</b></p>  <p>KUM_62Z_03F_B_WTS</p>	<p><b>C103-1,2</b></p>  <p>PKD_MP150_02F_GR</p>	<p><b>C105-1,2</b></p>  <p>PKD_150WP_03F_B_L</p>	<p><b>C106</b></p>  <p>PKD_GT150_08F_B</p>
<p><b>C116</b></p>  <p>YAZ_040WP_03F_B</p>	<p><b>C120</b></p>  <p>PKD_150WP_02F_B</p>	<p><b>C128-1,2,3,4,5,6</b></p>  <p>PKD_GT150_02F_B</p>	<p><b>C129</b></p>  <p>BSH_SENSOR_02F_B</p>
<p><b>C144-1</b></p>  <p>PKD_ECU_80F_Gr_1</p>		<p><b>C144-2</b></p>  <p>PKD_ECU_80F_B_2</p>	
<p><b>C130</b></p>  <p>PKD_GT150_05F_B</p>	<p><b>C135</b></p>  <p>AMP_JPT_02F_B_CLIP</p>	<p><b>C146/C149</b></p>  <p>PKD_GT150_04F_Gr</p>	<p><b>C147/C148</b></p>  <p>PKD_GT150_04F_B</p>



**MFI CONTROL SYSTEM**

**MFI CONTROL SYSTEM (GSL 3.3L) (8)**

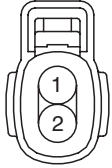
**SD313-14**

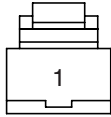
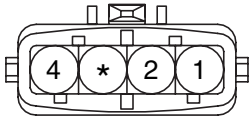
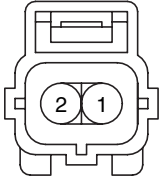
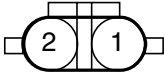
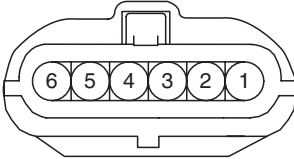
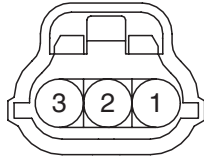
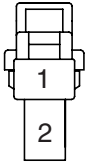
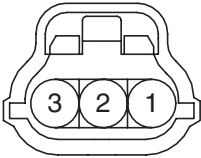
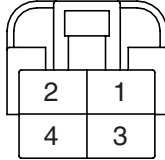
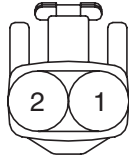
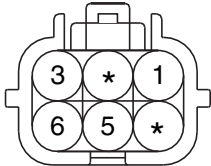
<p><b>C151-1,2,3,4,5,6</b></p>  <p>KET_090IWP_02F_Gr_VER</p>	<p><b>C153</b></p>  <p>CR01F021</p>	<p><b>C154</b></p>  <p>KET_250_01F_B_1</p>	<p><b>C157</b></p>  <p>AMP_JPT_04F_B_BOSCH</p>																																																
<p><b>C158</b></p>  <p>AMP_EJWP_02F_B</p>	<p><b>C161-1,2</b></p>  <p>CR02F134</p>	<p><b>E29</b></p>  <p>AMP_070WP_06F_B</p>	<p><b>E31</b></p>  <p>YAZ_040WP_03F_B</p>																																																
<p><b>E36</b></p>  <p>KET_250DL_02F_W</p>	<p><b>E61</b></p>  <p>YAZ_040WP_03F_B</p>	<p><b>E62</b></p>  <p>KET_250DL_04F_W</p>	<p><b>E67</b></p>  <p>KET_090IWP_02F_B</p>																																																
<p><b>F35</b></p>  <p>KET_SWP_06F_B</p>	<p><b>F60-A</b></p> <table border="1" data-bbox="663 1043 1088 1197"> <tr> <td>*</td><td>*</td><td>8</td><td>7</td><td>6</td><td>5</td><td>4</td><td>3</td><td>2</td><td>1</td> </tr> <tr> <td>20</td><td>19</td><td>18</td><td>*</td><td>16</td><td>*</td><td>*</td><td>*</td><td>*</td><td>11</td> </tr> </table> <p>AMP_040M2_20F_B</p>	*	*	8	7	6	5	4	3	2	1	20	19	18	*	16	*	*	*	*	11	<p><b>BLANK</b></p>	<p><b>M08-1</b></p> <table border="1" data-bbox="1615 1043 2040 1197"> <tr> <td>10</td><td>9</td><td>8</td><td>7</td><td>6</td><td>5</td><td>4</td><td>3</td><td>2</td><td>1</td> </tr> <tr> <td>20</td><td>19</td><td>18</td><td>17</td><td>16</td><td>15</td><td>14</td><td>13</td><td>12</td><td>11</td> </tr> </table> <p>AMP_040M2_20F_B</p>	10	9	8	7	6	5	4	3	2	1	20	19	18	17	16	15	14	13	12	11								
*	*	8	7	6	5	4	3	2	1																																										
20	19	18	*	16	*	*	*	*	11																																										
10	9	8	7	6	5	4	3	2	1																																										
20	19	18	17	16	15	14	13	12	11																																										
<p><b>M08-2</b></p> <table border="1" data-bbox="275 1331 517 1442"> <tr> <td>8</td><td>7</td><td>6</td><td>5</td><td>4</td><td>3</td><td>2</td><td>1</td> </tr> <tr> <td>16</td><td>15</td><td>14</td><td>13</td><td>12</td><td>11</td><td>10</td><td>*</td> </tr> </table> <p>AMP_040M2_16F_B</p>	8	7	6	5	4	3	2	1	16	15	14	13	12	11	10	*	<p><b>M08-3</b></p> <table border="1" data-bbox="763 1321 985 1453"> <tr> <td>6</td><td>5</td><td>4</td><td>3</td><td>2</td><td>1</td> </tr> <tr> <td>12</td><td>11</td><td>10</td><td>9</td><td>8</td><td>7</td> </tr> </table> <p>AMP_040M1_12F_B</p>	6	5	4	3	2	1	12	11	10	9	8	7	<p><b>M30-3</b></p> <table border="1" data-bbox="1223 1310 1471 1461"> <tr> <td>6</td><td>5</td><td>4</td><td>3</td><td>*</td><td>*</td> </tr> <tr> <td>12</td><td>11</td><td>10</td><td>9</td><td>*</td><td>*</td> </tr> </table> <p>AMP_025_12F_W</p>	6	5	4	3	*	*	12	11	10	9	*	*	<p><b>M72</b></p> <table border="1" data-bbox="1742 1318 1910 1458"> <tr> <td></td><td></td><td></td><td>1</td> </tr> <tr> <td>5</td><td>4</td><td>3</td><td>2</td> </tr> </table> <p>KUM_CDR_05F_W</p>				1	5	4	3	2
8	7	6	5	4	3	2	1																																												
16	15	14	13	12	11	10	*																																												
6	5	4	3	2	1																																														
12	11	10	9	8	7																																														
6	5	4	3	*	*																																														
12	11	10	9	*	*																																														
			1																																																
5	4	3	2																																																

MFI CONTROL SYSTEM (DIESEL) (1)

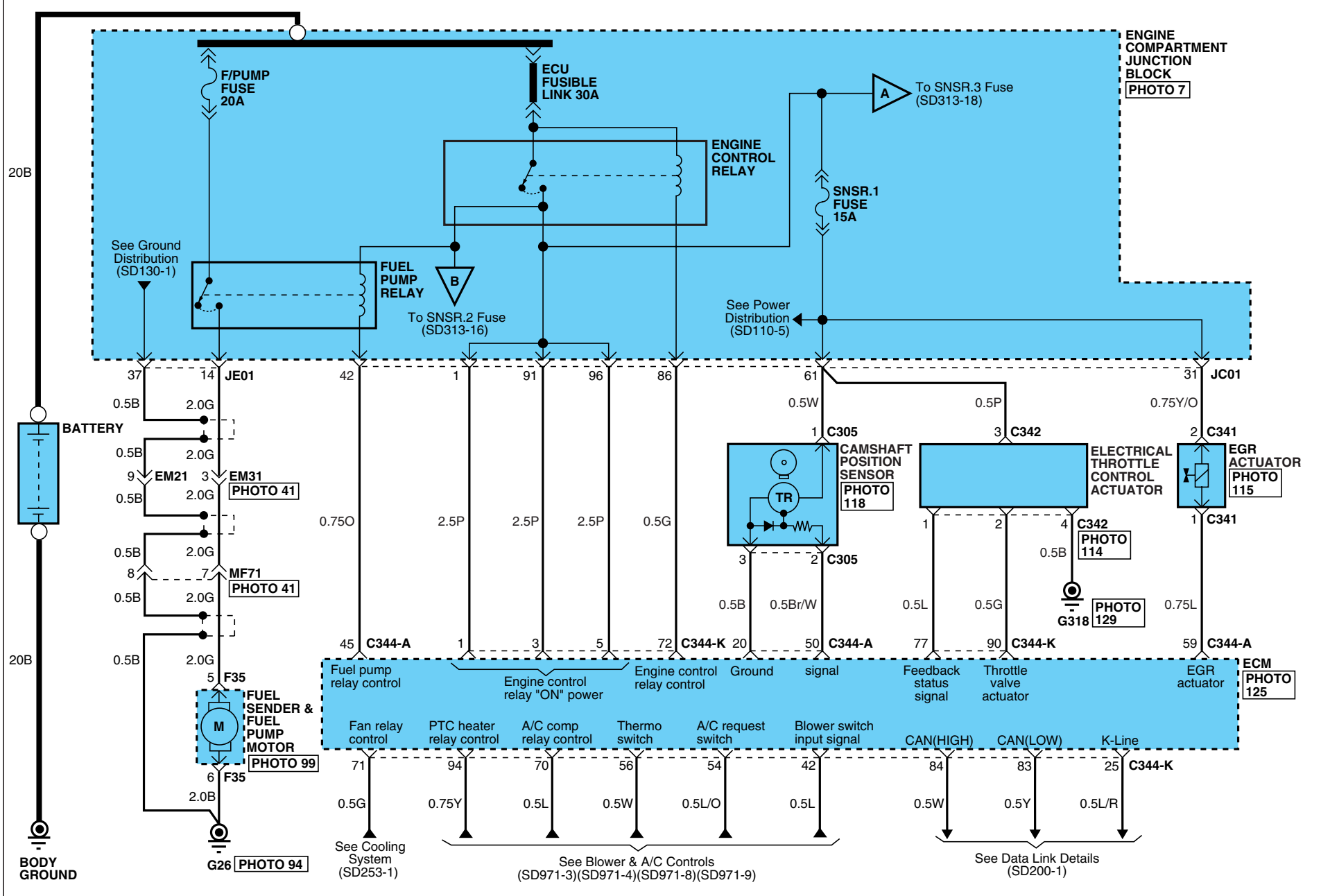

# MFI CONTROL SYSTEM

## MFI CONTROL SYSTEM (DIESEL) (2)

SD313-16

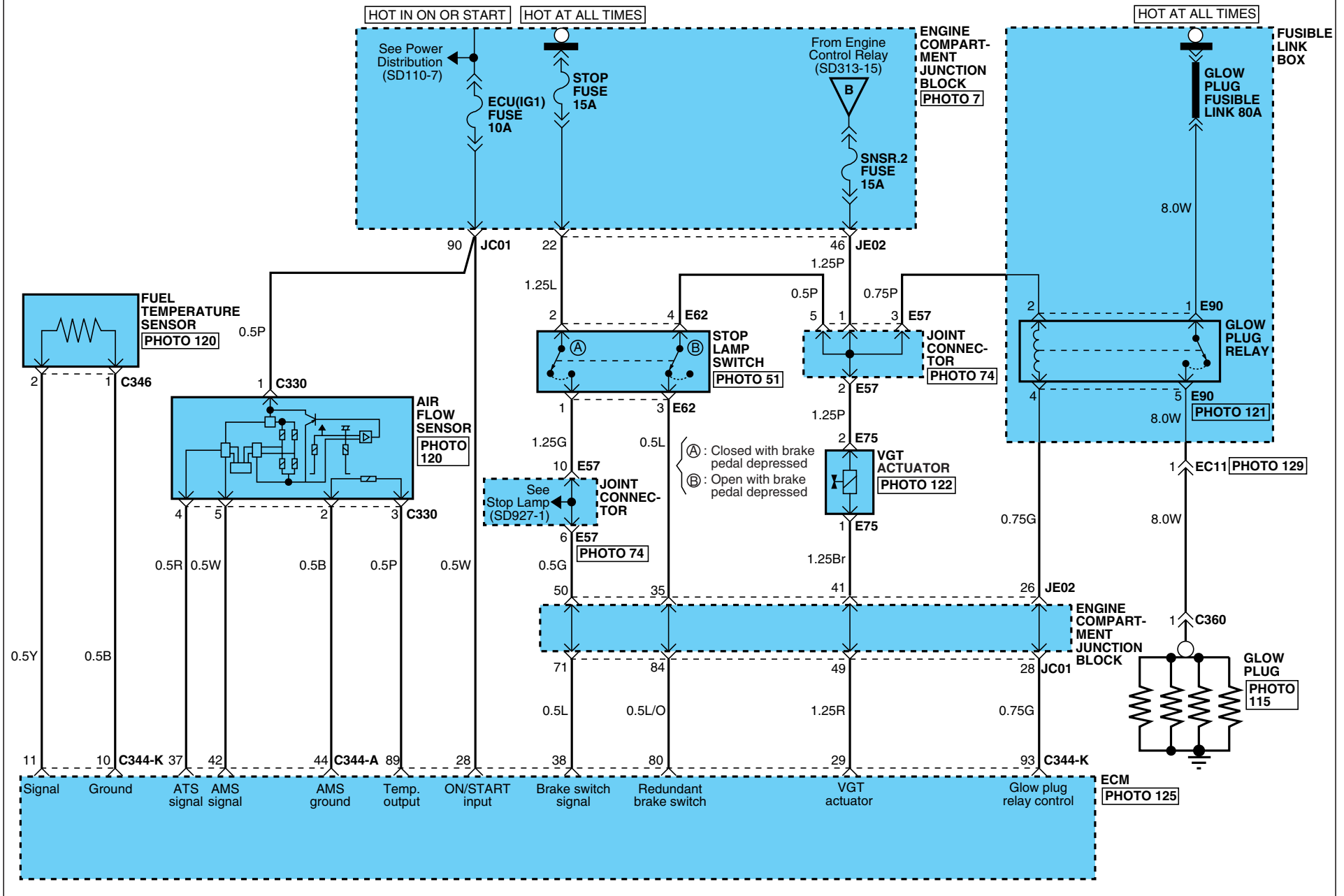

# MFI CONTROL SYSTEM

## MFI CONTROL SYSTEM (DIESEL) (3)

SD313-17

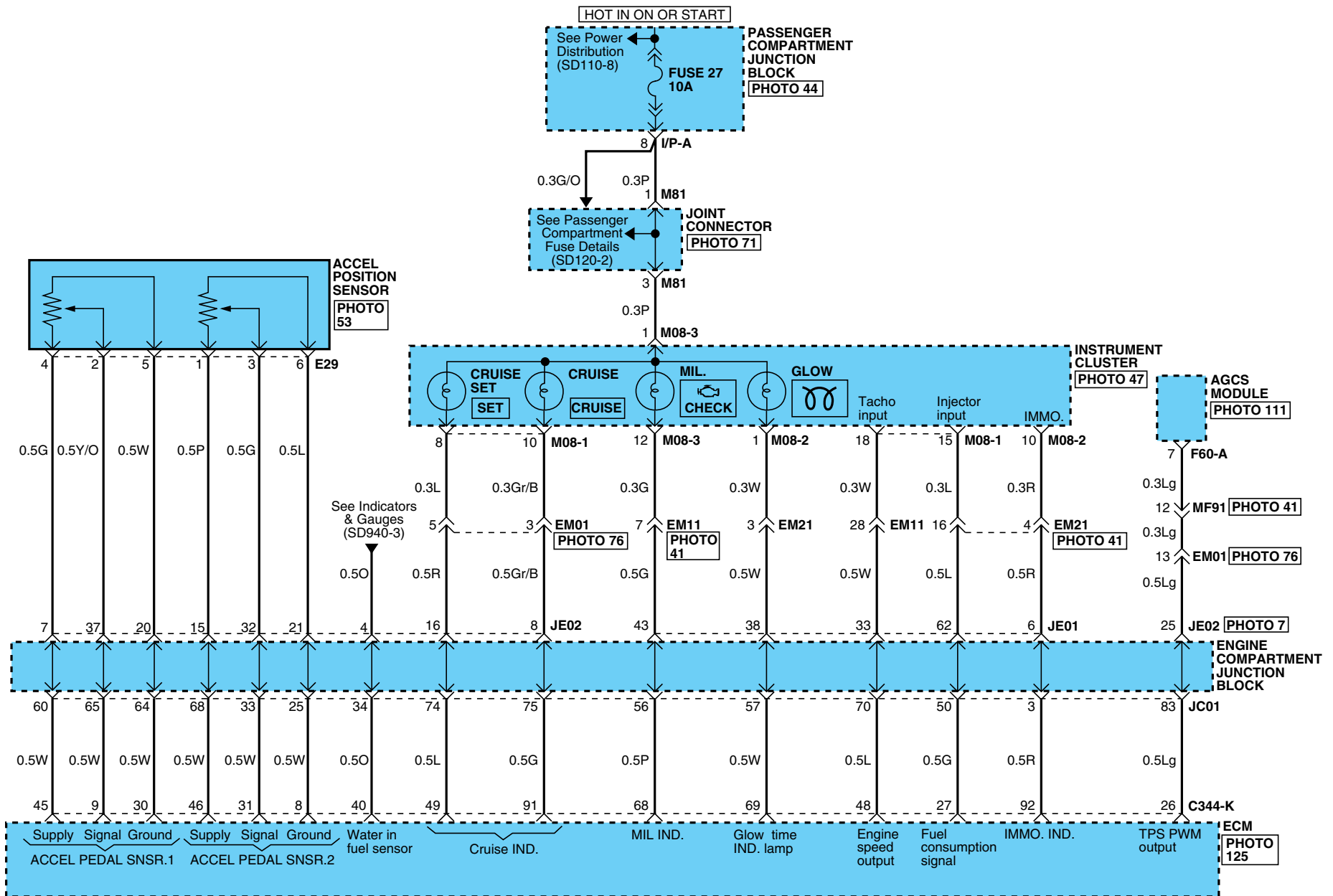

MFI CONTROL SYSTEM

MFI CONTROL SYSTEM (DIESEL) (4)

SD313-18

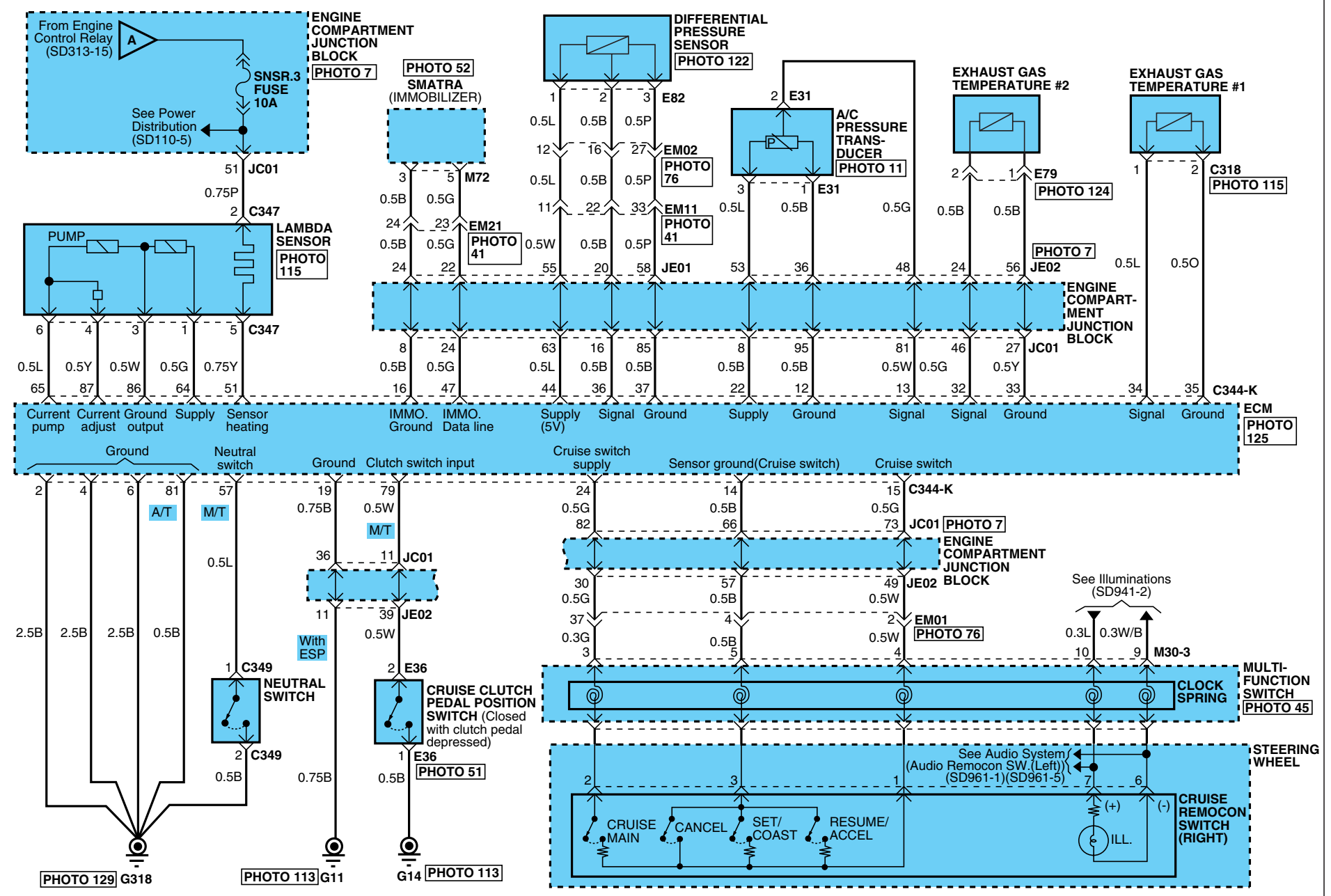

# MFI CONTROL SYSTEM

## MFI CONTROL SYSTEM (DIESEL) (5)



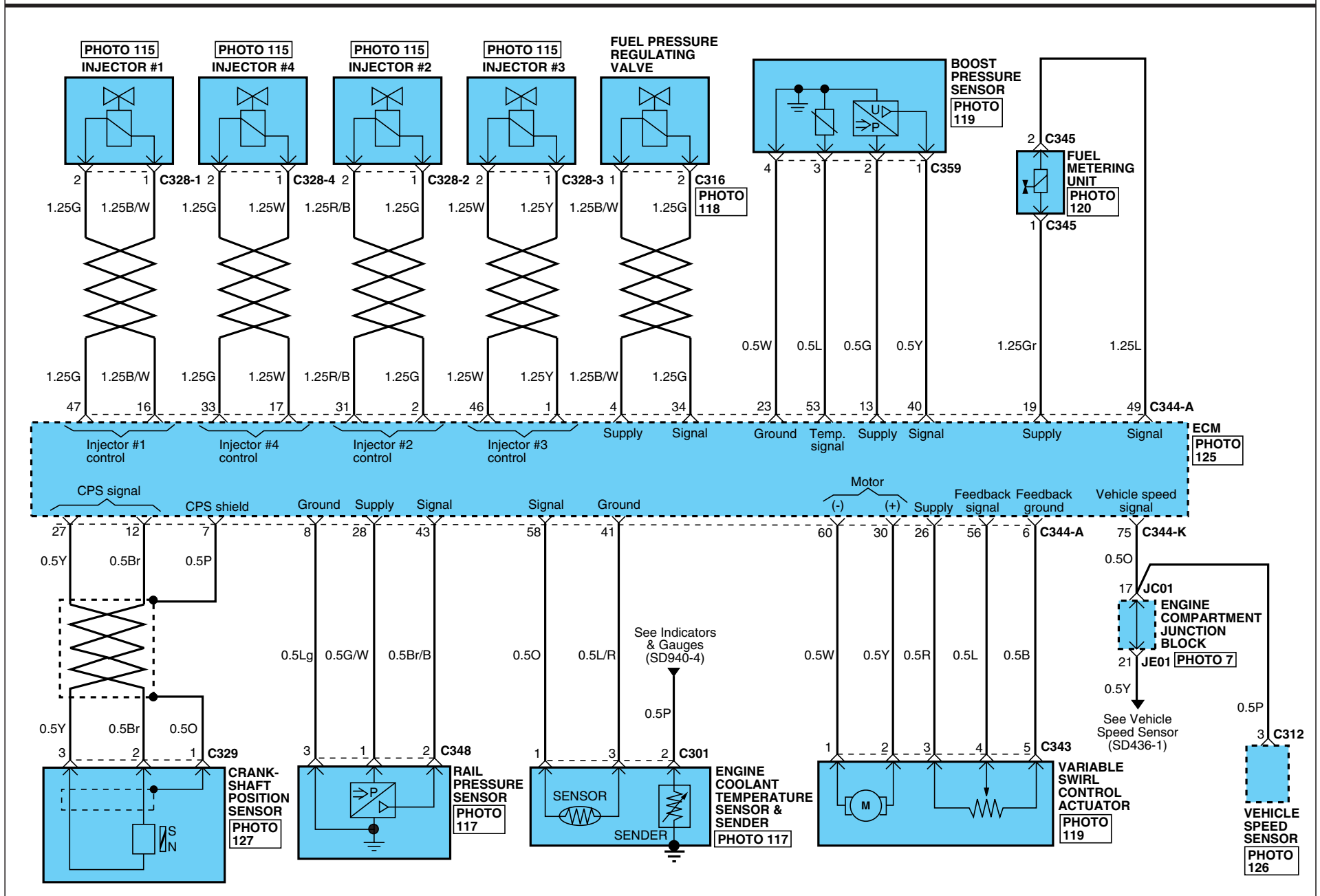



SD313-19

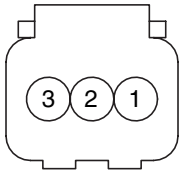

# MFI CONTROL SYSTEM

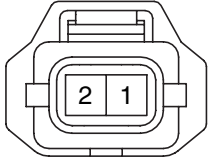
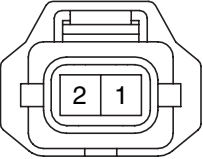
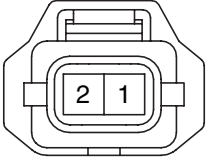
## MFI CONTROL SYSTEM (DIESEL) (6)

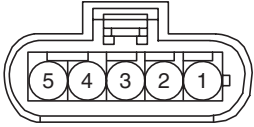
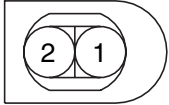
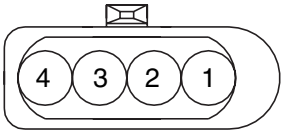
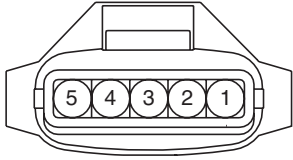
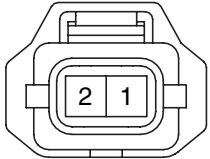
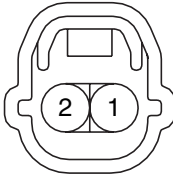

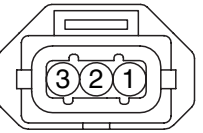
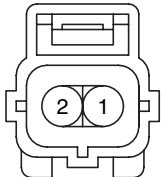
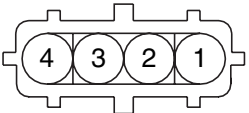
SD313-20

<p><b>C301</b></p>  <p>KUM_WTS_03F_B</p>	<p><b>C305</b></p>  <p>AMP_SFT_03F_B_1</p>	<p><b>C316</b></p>  <p>AMP_JPT_02F_BSH2_B</p>	<p><b>C318</b></p>  <p>AMP_JPT_02F_BSH2_B</p>																																																																																																
<p><b>C328-1/C328-2/C328-3/C328-4</b></p>  <p>AMP_JPT_02F_BSH2_B</p>	<p><b>C329</b></p>  <p>AMP_SFT_03F_B_1</p>	<p><b>C330</b></p>  <p>HSM_SENSOR_05F_B</p>	<p><b>C341</b></p>  <p>KST_SENSOR_02F_B_NF</p>																																																																																																
<p><b>C342</b></p>  <p>FEP_NFDSL_04F_N</p>	<p><b>C343</b></p>  <p>AMP_SFT_05F_B</p>	<p><b>C344-A</b></p> <table border="1" data-bbox="1301 794 1888 962"> <tr><td>60</td><td>59</td><td>58</td><td>*</td><td>56</td><td>*</td><td>*</td><td>53</td><td>*</td><td>*</td><td>50</td><td>49</td><td>*</td><td>47</td><td>46</td></tr> <tr><td>45</td><td>44</td><td>43</td><td>42</td><td>41</td><td>40</td><td>*</td><td>*</td><td>37</td><td>*</td><td>*</td><td>34</td><td>33</td><td>*</td><td>31</td></tr> <tr><td>30</td><td>*</td><td>28</td><td>27</td><td>26</td><td>*</td><td>*</td><td>23</td><td>*</td><td>*</td><td>20</td><td>19</td><td>*</td><td>17</td><td>16</td></tr> <tr><td>*</td><td>*</td><td>13</td><td>12</td><td>*</td><td>*</td><td>*</td><td>8</td><td>7</td><td>6</td><td>*</td><td>4</td><td>*</td><td>2</td><td>1</td></tr> </table> <p>AMP_ECU_60F_B</p>		60	59	58	*	56	*	*	53	*	*	50	49	*	47	46	45	44	43	42	41	40	*	*	37	*	*	34	33	*	31	30	*	28	27	26	*	*	23	*	*	20	19	*	17	16	*	*	13	12	*	*	*	8	7	6	*	4	*	2	1																																				
60	59	58	*	56	*	*	53	*	*	50	49	*	47	46																																																																																					
45	44	43	42	41	40	*	*	37	*	*	34	33	*	31																																																																																					
30	*	28	27	26	*	*	23	*	*	20	19	*	17	16																																																																																					
*	*	13	12	*	*	*	8	7	6	*	4	*	2	1																																																																																					
<p><b>C344-K</b></p> <table border="1" data-bbox="271 1062 999 1214"> <tr><td>94</td><td>93</td><td>92</td><td>91</td><td>90</td><td>89</td><td>*</td><td>87</td><td>86</td><td>*</td><td>84</td><td>83</td><td>*</td><td>81</td><td>80</td><td>79</td><td>*</td><td>77</td><td>*</td><td>75</td><td>*</td><td>*</td><td>6</td><td>5</td></tr> <tr><td>72</td><td>71</td><td>70</td><td>69</td><td>68</td><td>*</td><td>*</td><td>65</td><td>64</td><td>*</td><td>*</td><td>*</td><td>*</td><td>*</td><td>57</td><td>56</td><td>*</td><td>54</td><td>*</td><td>*</td><td>51</td><td></td><td>4</td><td>3</td></tr> <tr><td>*</td><td>49</td><td>48</td><td>47</td><td>46</td><td>45</td><td>44</td><td>*</td><td>42</td><td>*</td><td>40</td><td>*</td><td>38</td><td>37</td><td>36</td><td>35</td><td>34</td><td>33</td><td>32</td><td>31</td><td>30</td><td>29</td><td>2</td><td>1</td></tr> <tr><td>28</td><td>27</td><td>26</td><td>25</td><td>24</td><td>*</td><td>22</td><td>*</td><td>19</td><td>*</td><td>*</td><td>16</td><td>15</td><td>14</td><td>13</td><td>12</td><td>11</td><td>10</td><td>9</td><td>8</td><td>*</td><td></td><td></td><td></td></tr> </table> <p>AMP_ECU_94F_B</p>		94	93	92	91	90	89	*	87	86	*	84	83	*	81	80	79	*	77	*	75	*	*	6	5	72	71	70	69	68	*	*	65	64	*	*	*	*	*	57	56	*	54	*	*	51		4	3	*	49	48	47	46	45	44	*	42	*	40	*	38	37	36	35	34	33	32	31	30	29	2	1	28	27	26	25	24	*	22	*	19	*	*	16	15	14	13	12	11	10	9	8	*				<p><b>C345</b></p>  <p>AMP_JPT_02F_BSH2_B</p>	<p><b>C346</b></p>  <p>KET_SSD_02F_B</p>
94	93	92	91	90	89	*	87	86	*	84	83	*	81	80	79	*	77	*	75	*	*	6	5																																																																												
72	71	70	69	68	*	*	65	64	*	*	*	*	*	57	56	*	54	*	*	51		4	3																																																																												
*	49	48	47	46	45	44	*	42	*	40	*	38	37	36	35	34	33	32	31	30	29	2	1																																																																												
28	27	26	25	24	*	22	*	19	*	*	16	15	14	13	12	11	10	9	8	*																																																																															
<p><b>C347</b></p>  <p>BSH_SENSOR_06F_B_NF</p>	<p><b>C348</b></p>  <p>AMP_SFT_03F_B_2</p>	<p><b>C349</b></p>  <p>AMP_EJWP_02F_B</p>	<p><b>C359</b></p>  <p>BSH_SENSOR_04F_B_DSL</p>																																																																																																

# MFI CONTROL SYSTEM

## MFI CONTROL SYSTEM (DIESEL) (7)

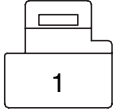
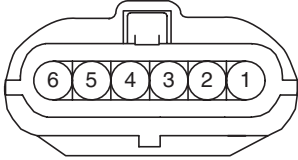
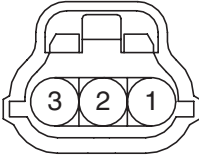
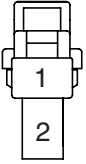
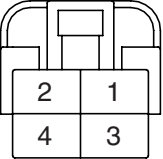
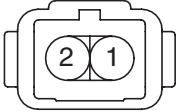
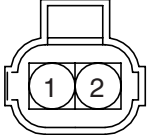
SD313-21

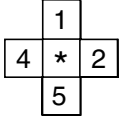
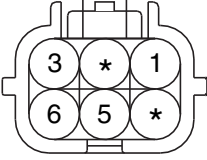
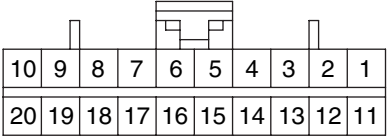
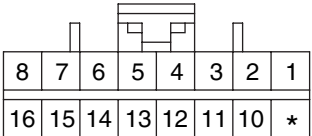
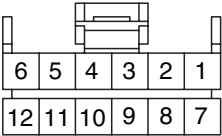
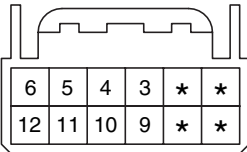
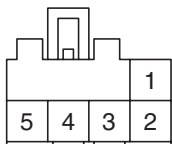
<p><b>C360</b></p>  <p>KET_58L_01F_B</p>	<p><b>E29</b></p>  <p>AMP_070WP_06F_B</p>	<p><b>E31</b></p>  <p>YAZ_040WP_03F_B</p>	<p><b>E36</b></p>  <p>KET_250DL_02F_W</p>
<p><b>E62</b></p>  <p>KET_250DL_04F_W</p>	<p><b>BLANK</b></p>	<p><b>E75</b></p>  <p>KET_ITC_02F_B</p>	<p><b>E79</b></p>  <p>SUM_SENSOR_02M_W</p>
<p><b>E82</b></p>  <p>SUM_090IWP_03F</p>	<p><b>E90</b></p>  <p>CR05F019</p>	<p><b>F35</b></p>  <p>KET_SWP_06F_B</p>	<p><b>M08-1</b></p>  <p>AMP_040M2_20F_B</p>
<p><b>M08-2</b></p>  <p>AMP_040M2_16F_B</p>	<p><b>M08-3</b></p>  <p>AMP_040M1_12F_B</p>	<p><b>M30-3</b></p>  <p>AMP_025_12F_W</p>	<p><b>M72</b></p>  <p>KUM_CDR_05F_W</p>
Empty row for additional connectors			



**MFI CONTROL SYSTEM**

**MFI CONTROL SYSTEM (DIESEL) (8)**

**SD313-22**

**MEMO**

STARTING SYSTEM (1)

SD360-1

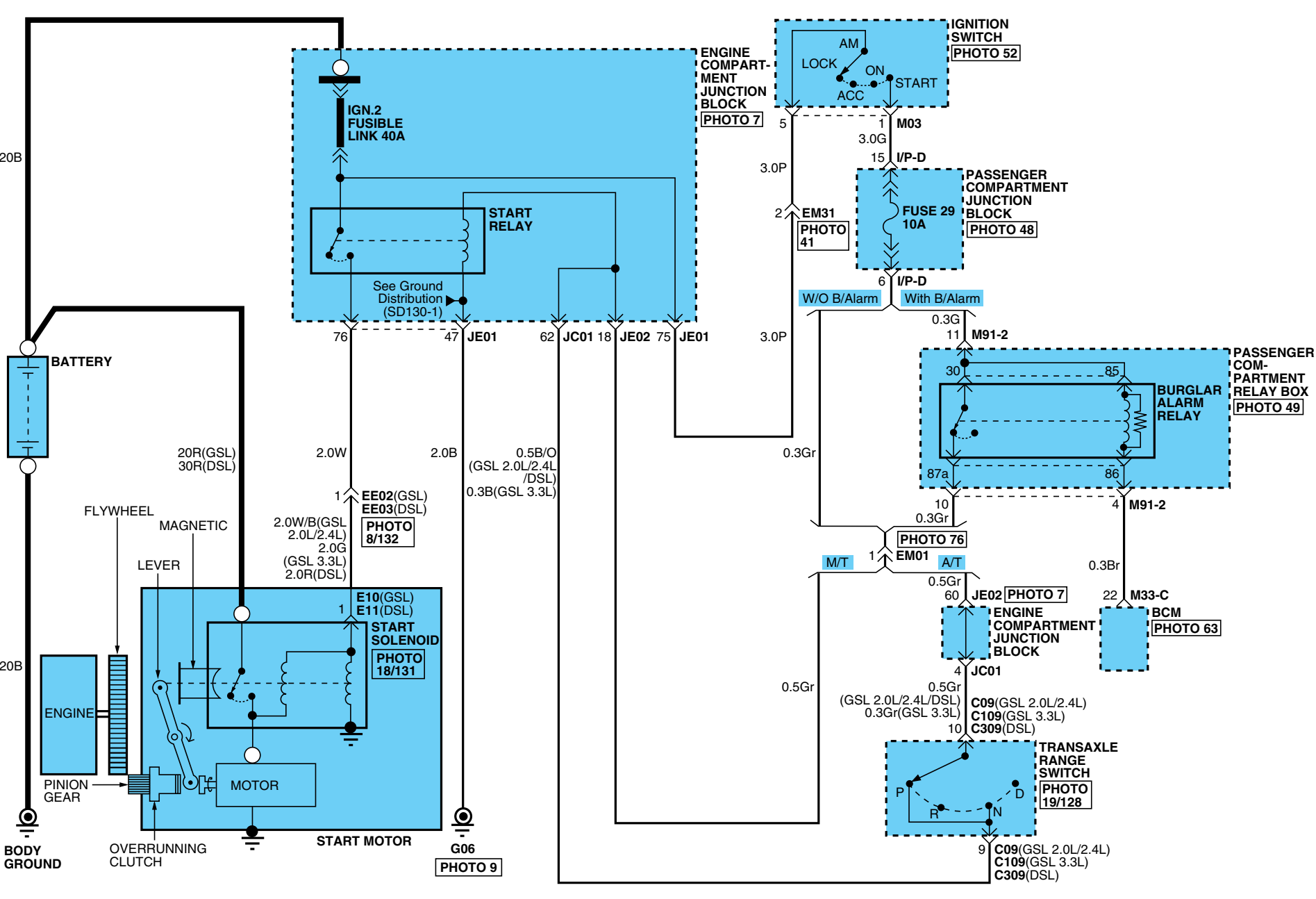

**STARTING SYSTEM**

**STARTING SYSTEM (2)**

**SD360-2**

**C09/C109**



KET\_SSD\_10F\_B\_A

**C309**



KET\_SSD\_10F\_B\_A

**E10**

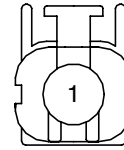

KET\_250WP58X\_01F\_B

**E11**

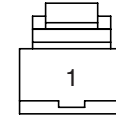

KET\_250\_01F\_B

**M03**

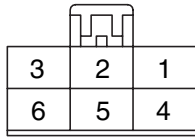

KUM\_DSD\_06F\_W

**M33-C**

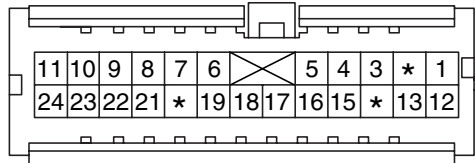

AMP\_040III\_24F\_GR

**M91-2**

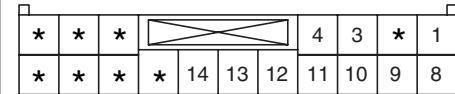

AMP\_0925\_18F\_W

FUEL FILTER HEATING SYSTEM (DIESEL) (1)

SD361-1

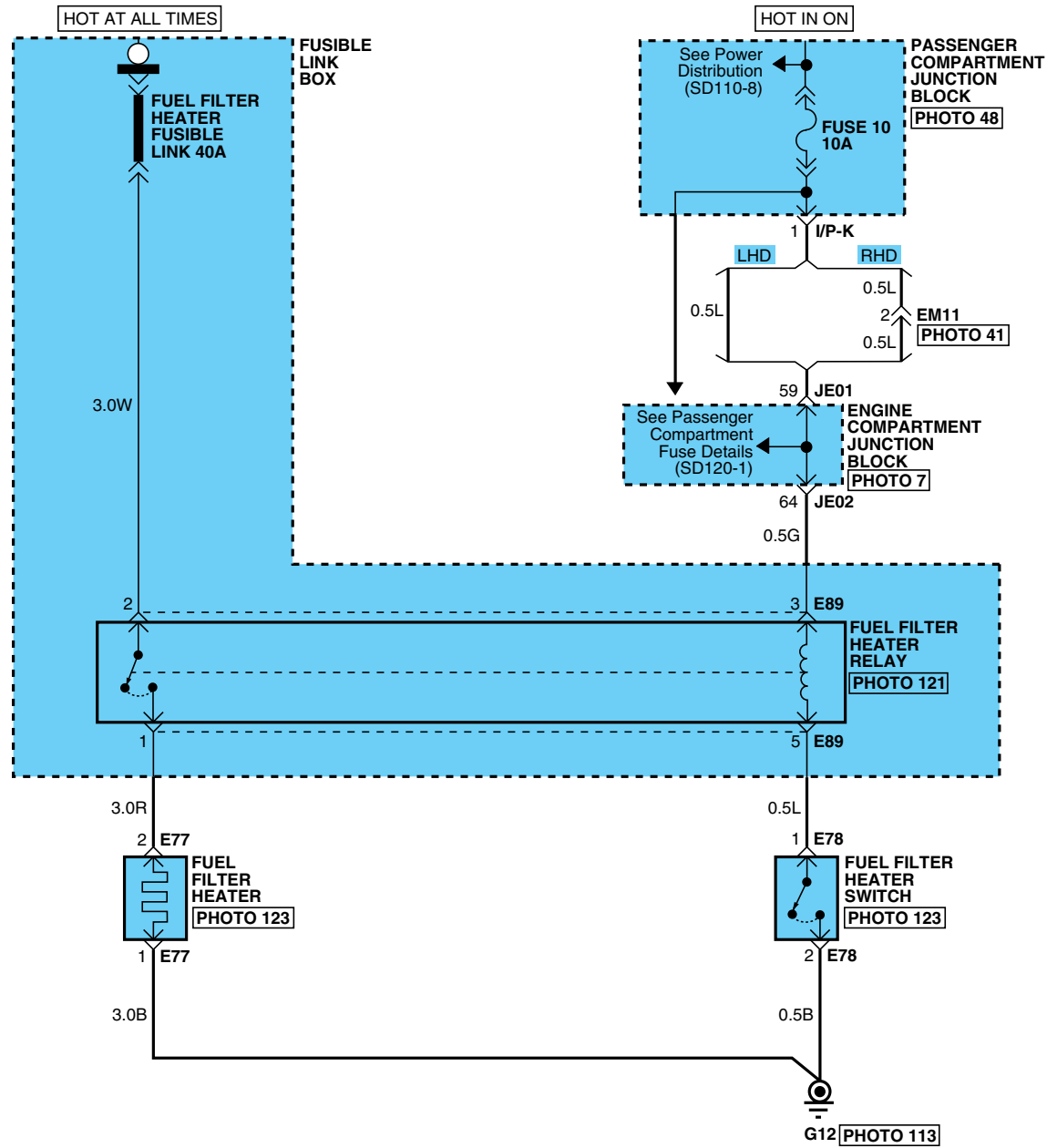

# FUEL FILTER HEATING SYSTEM

## FUEL FILTER HEATING SYSTEM (DIESEL) (2)

SD361-2

E77

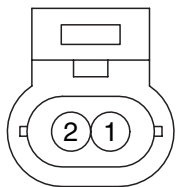

PKD\_280WP\_02F\_B

E78

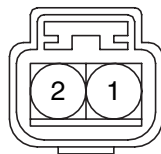

KUM\_NMWP\_02F\_B

E89

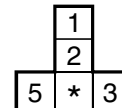

CR05F011

BLANK

CHARGING SYSTEM (1)

SD373-1

**GASOLINE**

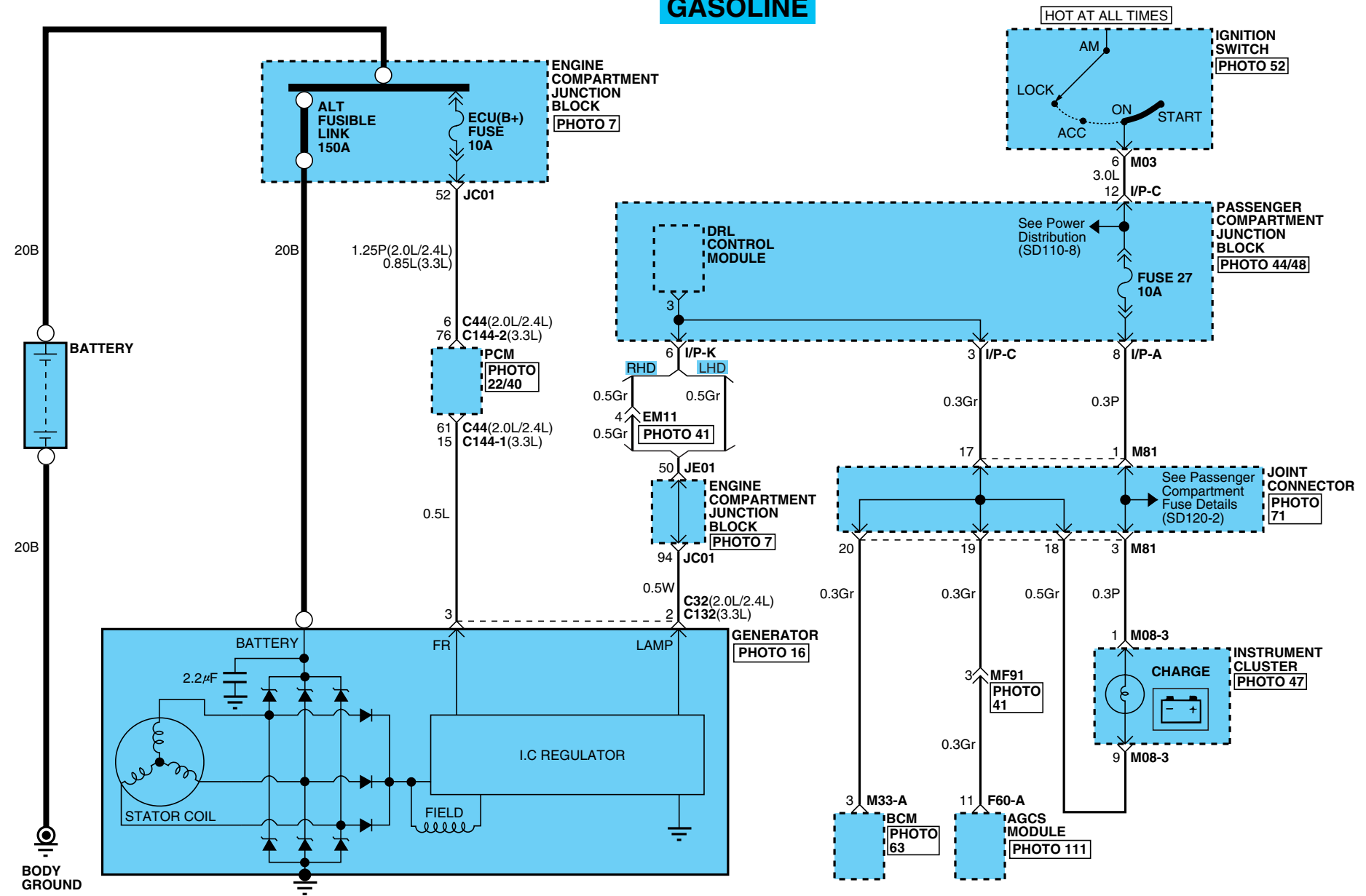

# CHARGING SYSTEM

## CHARGING SYSTEM (2)

SD373-2

**DIESEL**

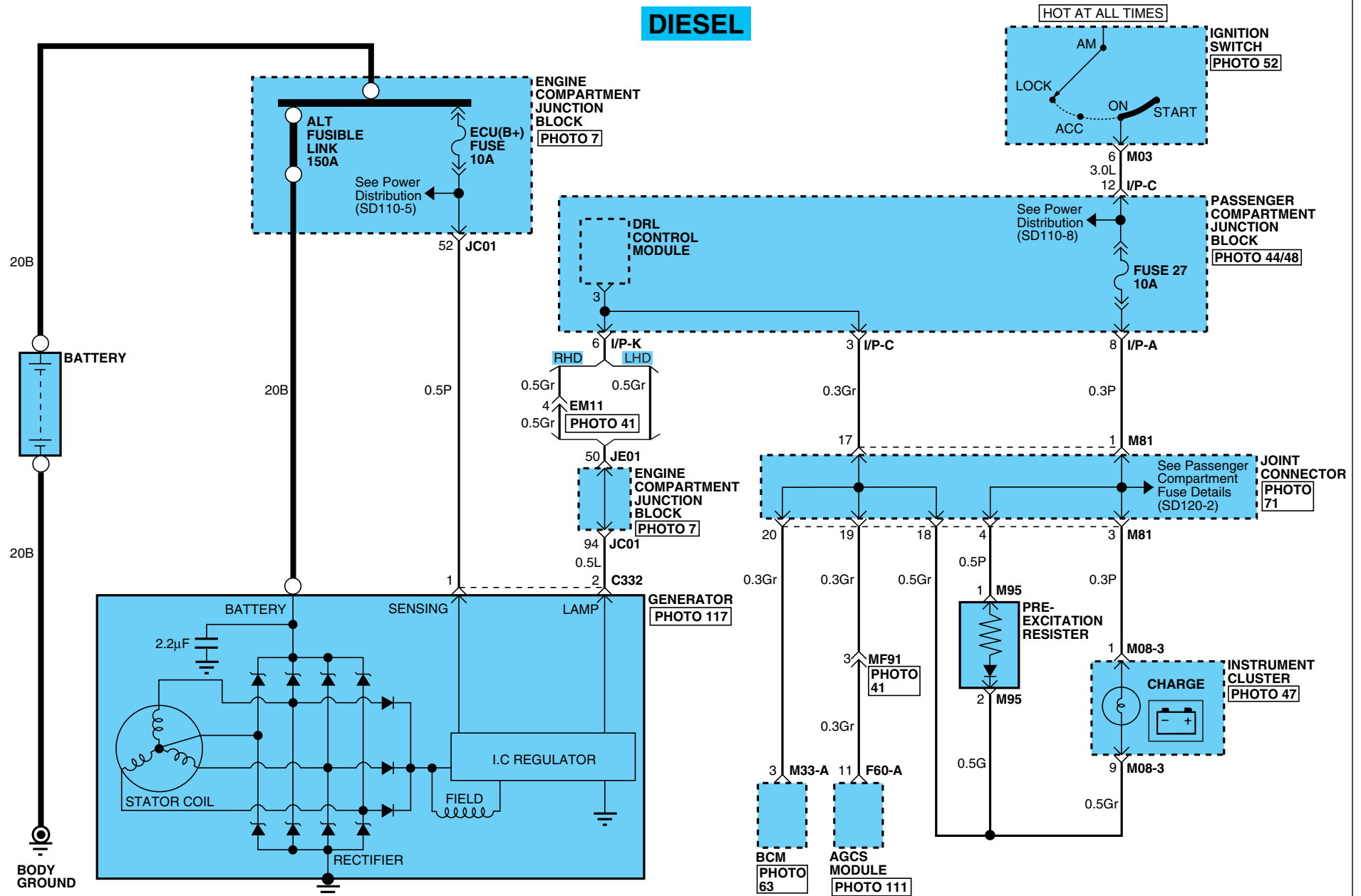

# CHARGING SYSTEM

## CHARGING SYSTEM (3)

SD373-3

**C32**

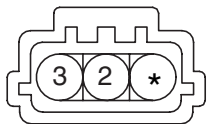

SUM\_ALTWP\_03F\_B

**C132**

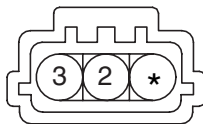

SUM\_ALTWP\_03F\_GR

**C332**

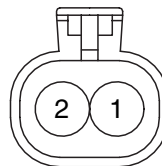

KET\_58X\_02F\_B

**F60-A**

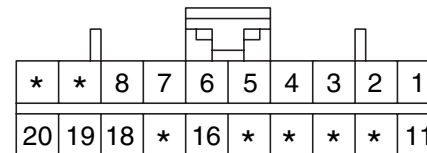

AMP\_040M2\_20F\_B

**M03**

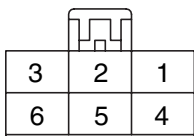

KUM\_DSD\_06F\_W

**M08-3**

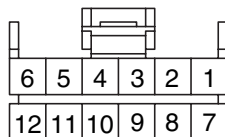

AMP\_040M1\_12F\_B

**M33-A**

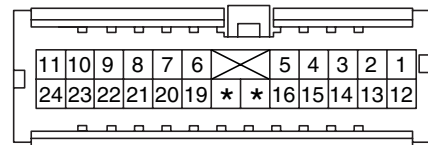

AMP\_040III\_24F\_W

**M95**

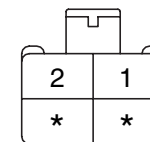

KET\_250\_04F\_W



**CHARGING SYSTEM**

**CHARGING SYSTEM (4)**

**SD373-4**

**MEMO**

VEHICLE SPEED SENSOR (1)

SD436-1

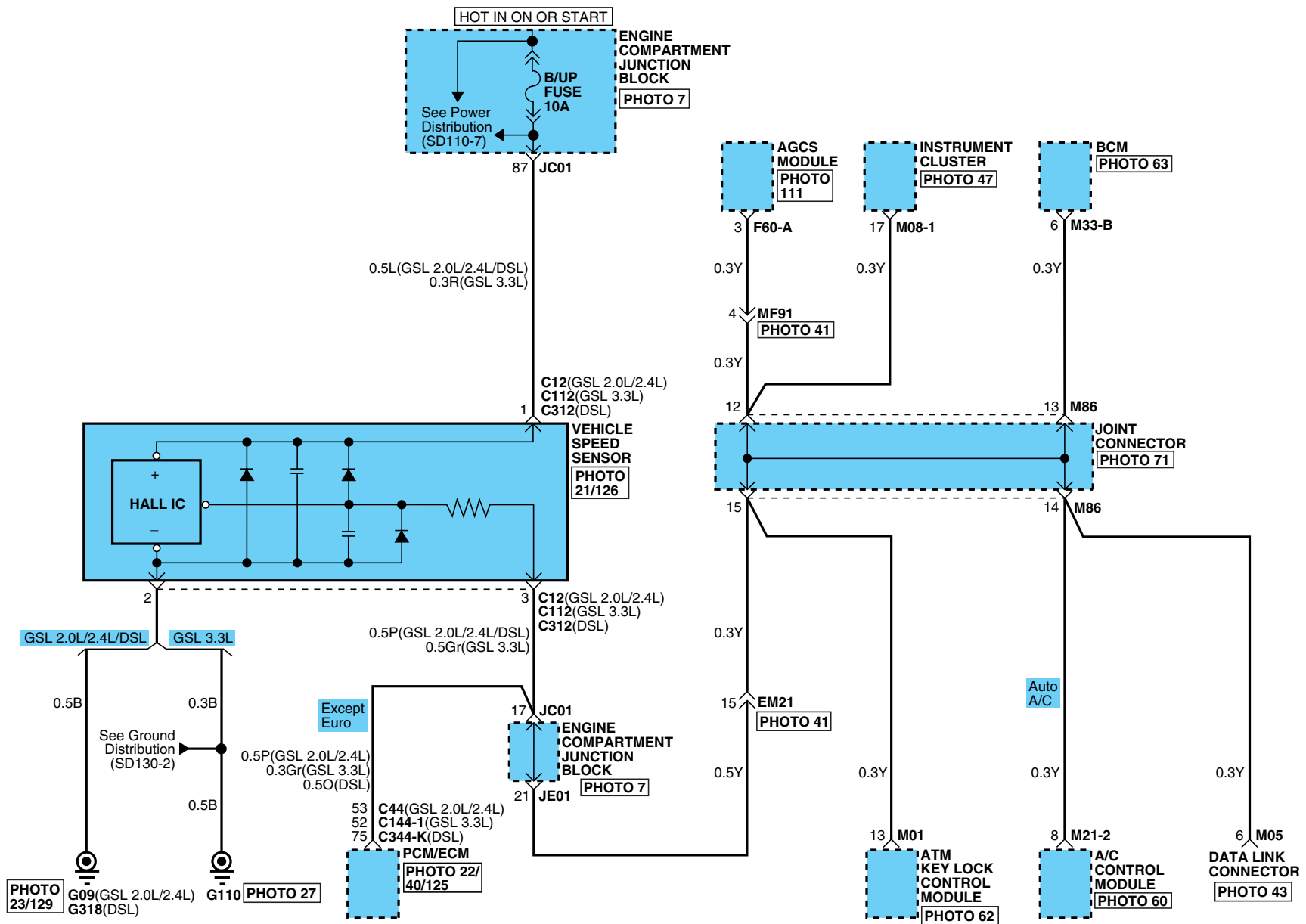

# VEHICLE SPEED SENSOR

## VEHICLE SPEED SENSOR (2)

SD436-2

**C12(A/T)**

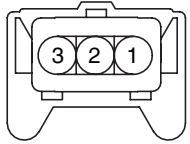

AMP\_JPT\_03F\_B\_S1

**C12(M/T)**

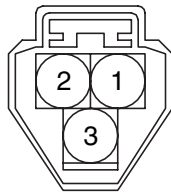

KUM\_NMWP\_03F\_B

**C112**

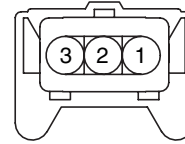

AMP\_JPT\_03F\_B\_S1

**C312**

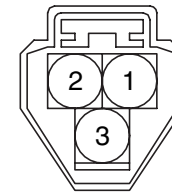

KUM\_NMWP\_03F\_B

**F60-A**

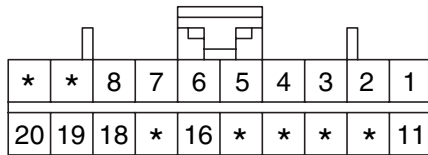

AMP\_040M2\_20F\_B

**M01**

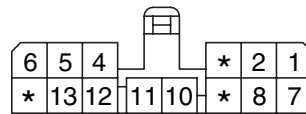

AMP\_070\_14F\_W

**M05**

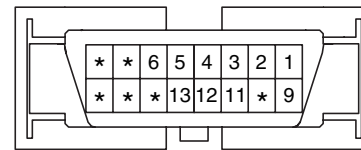

MLX\_OBDII\_16F\_B\_SIN

**M08-1**

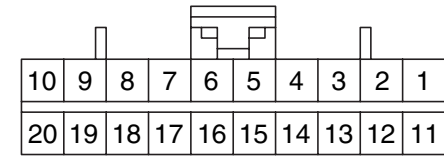

AMP\_040M2\_20F\_B

**M21-2**

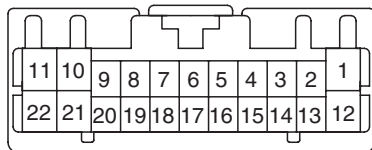

KET\_0407\_22F\_W

**M33-B**

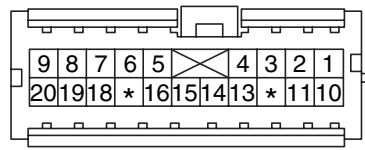

AMP\_040III\_20F\_W

**BLANK**

**BLANK**



# AUTOMATIC TRANSAXLE CONTROL SYSTEM

## AUTOMATIC TRANSAXLE CONTROL SYSTEM (GSL 2.0L/2.4L) (2)

SD450-2

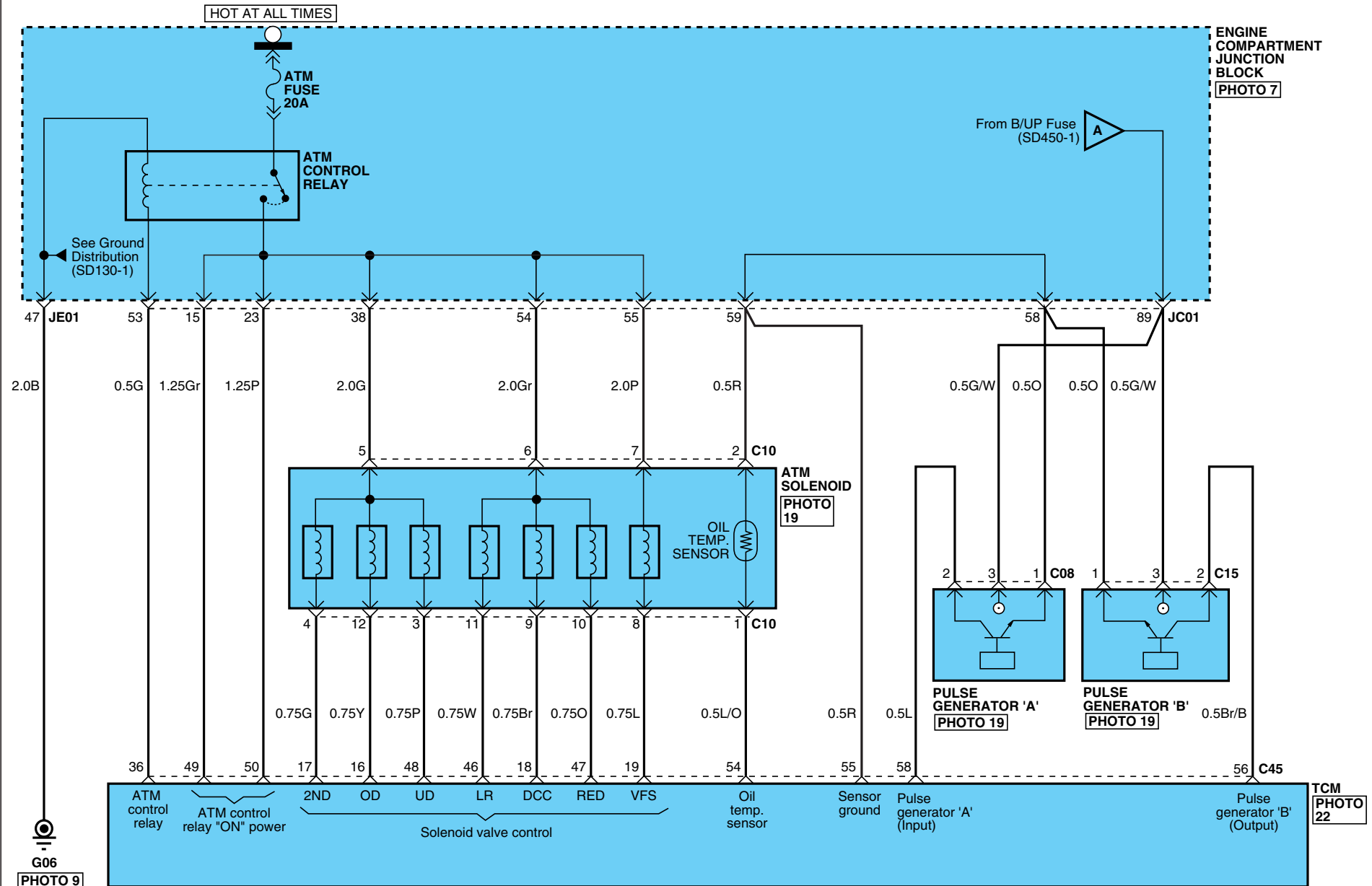

# AUTOMATIC TRANSAXLE CONTROL SYSTEM

## AUTOMATIC TRANSAXLE CONTROL SYSTEM (GSL 2.0L/2.4L) (3)

SD450-3

**C08**

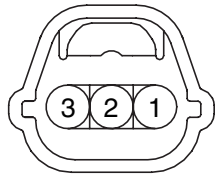

KET\_SSD\_03F\_B\_A

**C09**



KET\_SSD\_10F\_B\_A

**C10**



KET\_SSD\_12F\_B

**BLANK**

**C15**

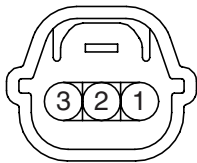

KET\_SSD\_03F\_Gr\_B

**C45**

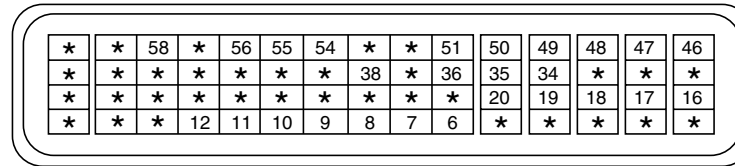

SIE\_TCU\_60F\_B

**M40**

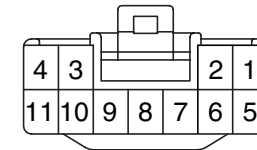

KET\_090II\_11F\_W

**AUTOMATIC TRANSAXLE CONTROL SYSTEM**

**AUTOMATIC TRANSAXLE CONTROL SYSTEM (GSL 2.0L/2.4L) (4)**

**SD450-4**

**MEMO**





# AUTOMATIC TRANSAXLE CONTROL SYSTEM

## AUTOMATIC TRANSAXLE CONTROL SYSTEM (GSL 3.3L) (2)

SD450-6

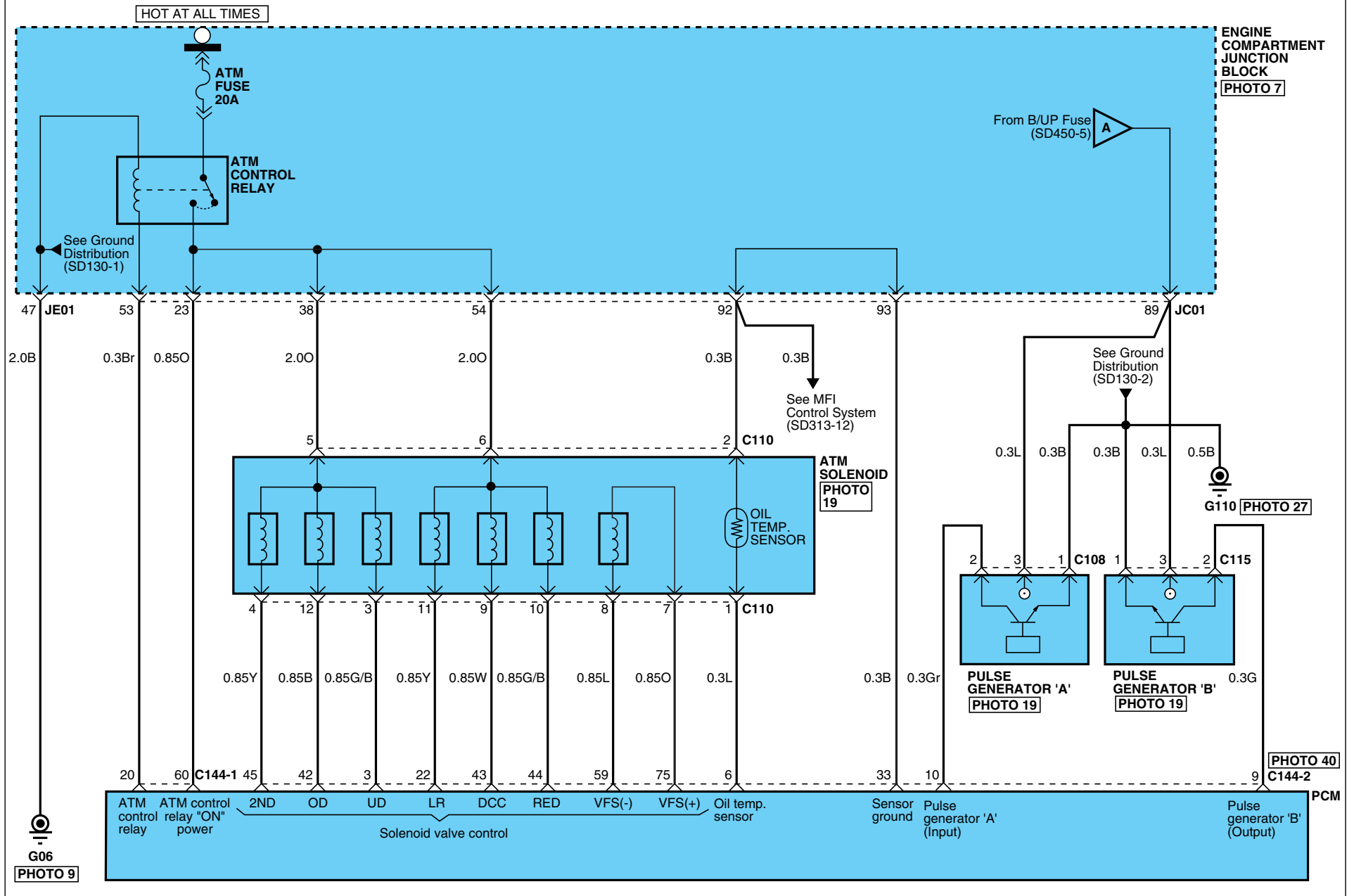

# AUTOMATIC TRANSAXLE CONTROL SYSTEM

## AUTOMATIC TRANSAXLE CONTROL SYSTEM (GSL 3.3L) (3)

SD450-7

**C108**

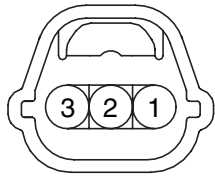

KET\_SSD\_03F\_B\_A

**C109**



KET\_SSD\_10F\_B\_A

**C110**



KET\_SSD\_12F\_B

**C115**

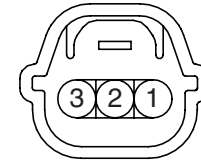

KET\_SSD\_03F\_Gr\_B

**C144-1**

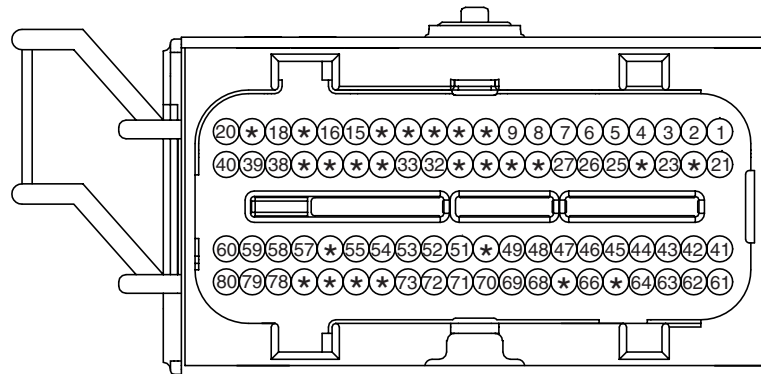

PKD\_ECU\_80F\_Gr\_1

**C144-2**

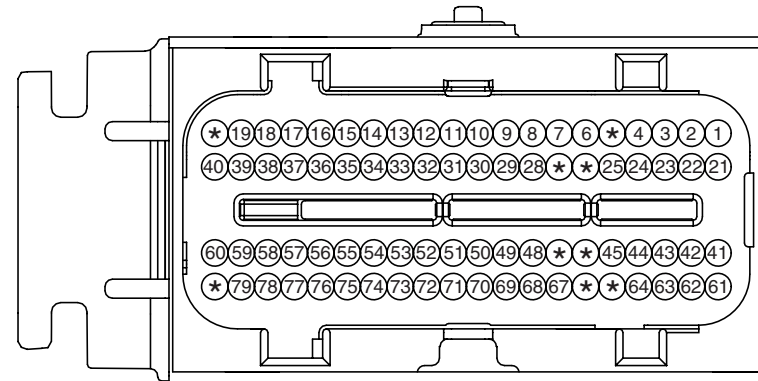

PKD\_ECU\_80F\_B\_2

**M40**

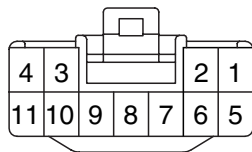

KET\_090II\_11F\_W

**BLANK**

**BLANK**

**BLANK**

**AUTOMATIC TRANSAXLE CONTROL SYSTEM**

**AUTOMATIC TRANSAXLE CONTROL SYSTEM (GSL 3.3L) (4)**

**SD450-8**

**MEMO**

# AUTOMATIC TRANSAXLE CONTROL SYSTEM E760A6ED

## AUTOMATIC TRANSAXLE CONTROL SYSTEM (DIESEL) (1)

SD450-9

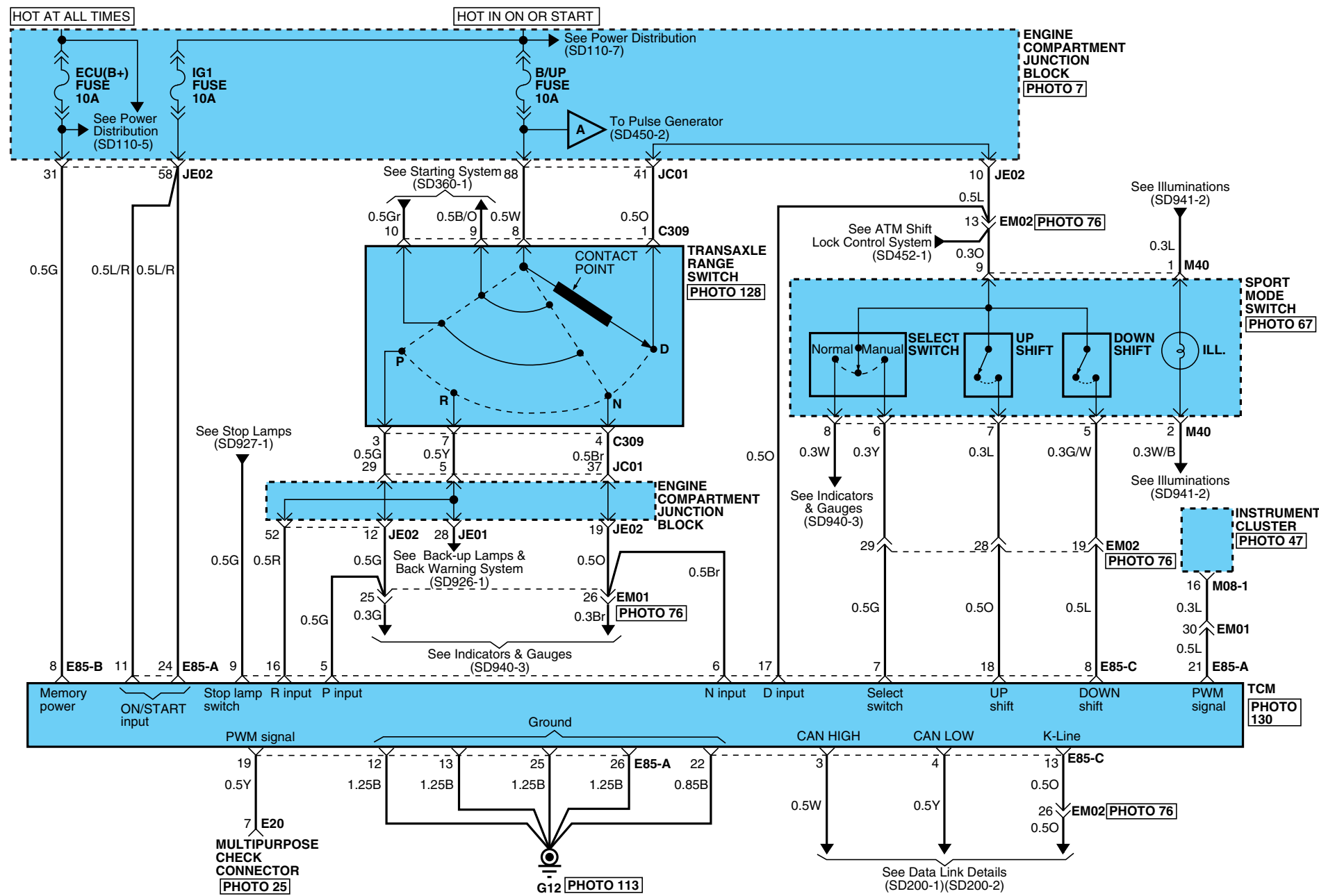

# AUTOMATIC TRANSAXLE CONTROL SYSTEM

## AUTOMATIC TRANSAXLE CONTROL SYSTEM (DIESEL) (2)

SD450-10

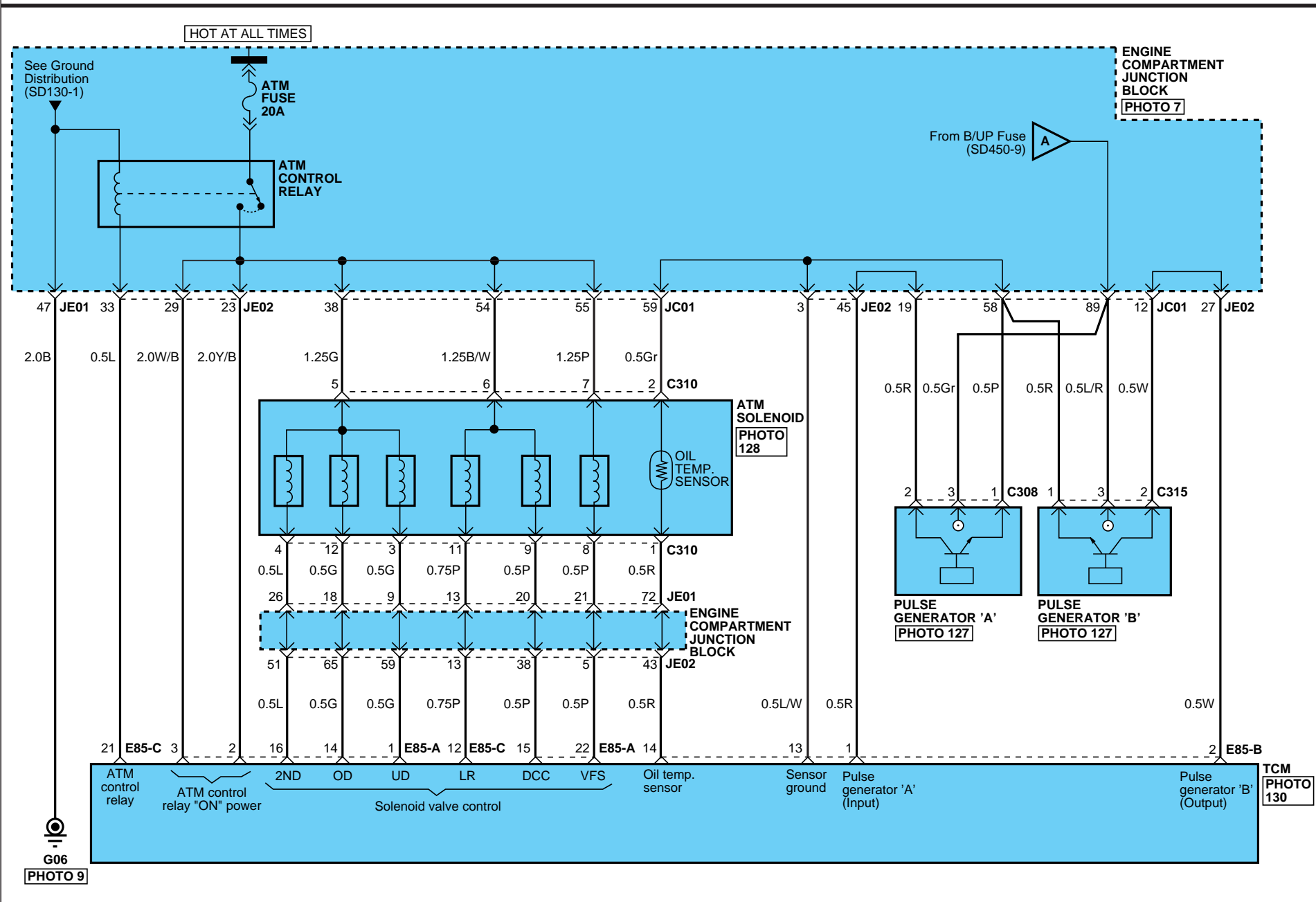

# AUTOMATIC TRANSAXLE CONTROL SYSTEM

## AUTOMATIC TRANSAXLE CONTROL SYSTEM (DIESEL) (3)

SD450-11

**C308**

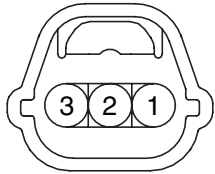

KET\_SSD\_03F\_B\_A

**C309**



KET\_SSD\_10F\_B\_A

**C310**



KET\_SSD\_12F\_B

**C315**

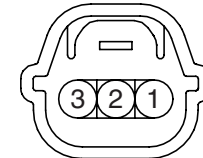

KET\_SSD\_03F\_Gr\_B

**E85-A**

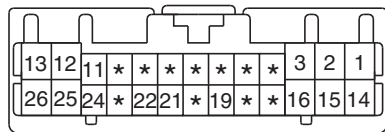

KET\_0407\_26F\_W

**E85-B**

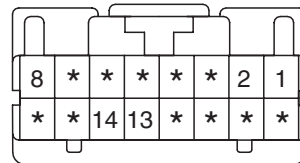

KET\_0407\_16F\_W

**E85-C**

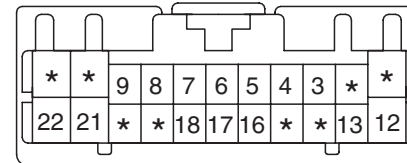

KET\_0407\_22F\_W

**M40**

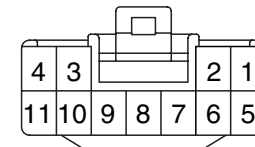

KET\_090II\_11F\_W

**AUTOMATIC TRANSAXLE CONTROL SYSTEM**

**AUTOMATIC TRANSAXLE CONTROL SYSTEM (DIESEL) (4)**

**SD450-12**

**MEMO**

ATM SHIFT LOCK CONTROL SYSTEM (1)

SD452-1

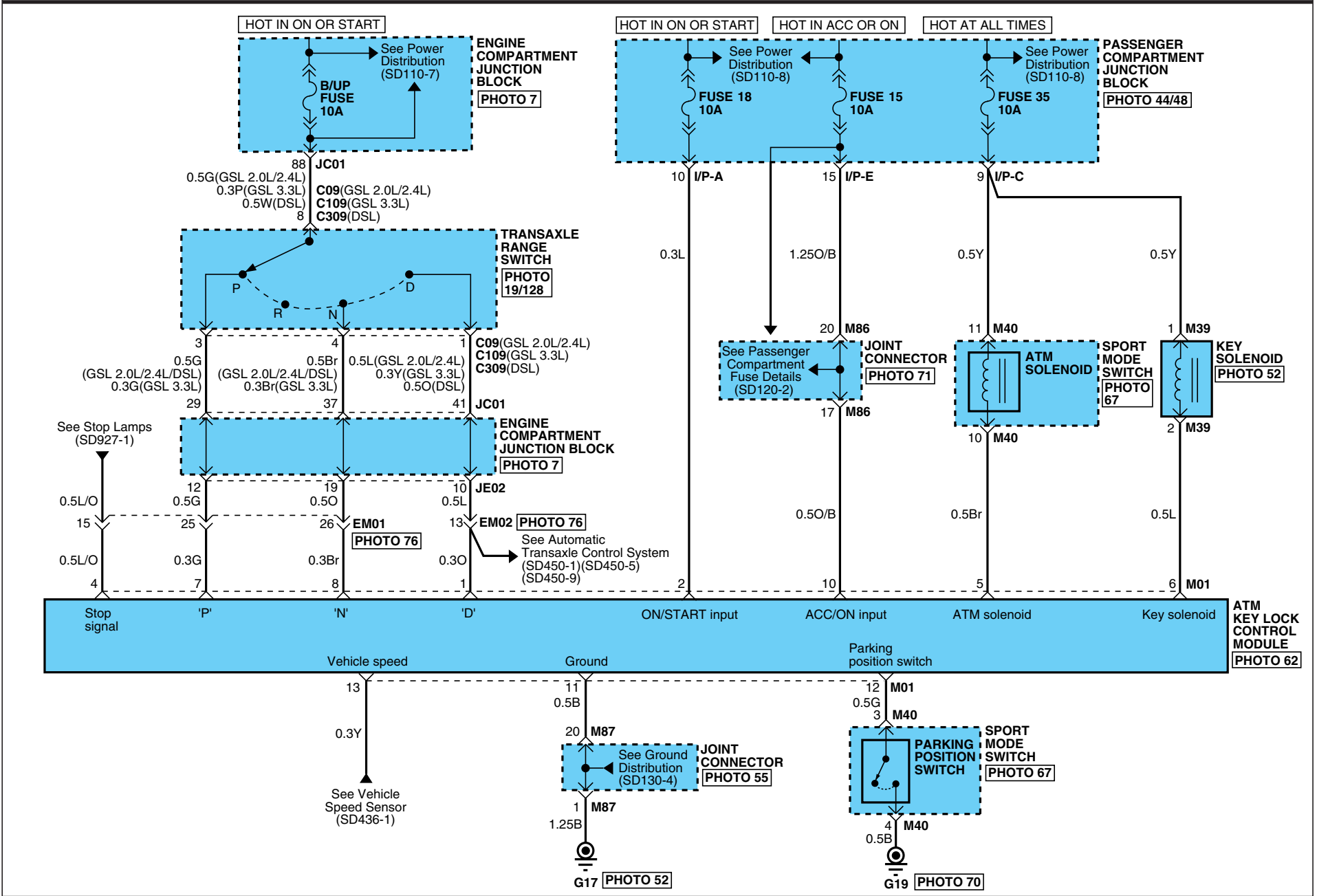



# ATM SHIFT LOCK CONTROL SYSTEM

## ATM SHIFT LOCK CONTROL SYSTEM (2)

SD452-2

C09/C109/C309



KET\_SSD\_10F\_B\_A

M01

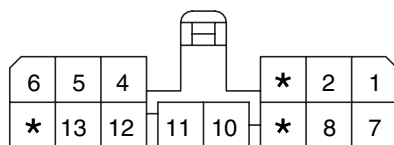

AMP\_070\_14F\_W

M39

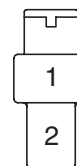

KET\_250\_02F\_W

M40

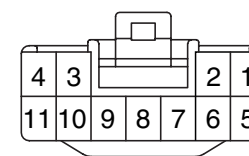

KET\_090I1\_11F\_W



# AIR BAG SYSTEM (SRS)

## AIR BAG SYSTEM (SRS) (2)

SD569-2

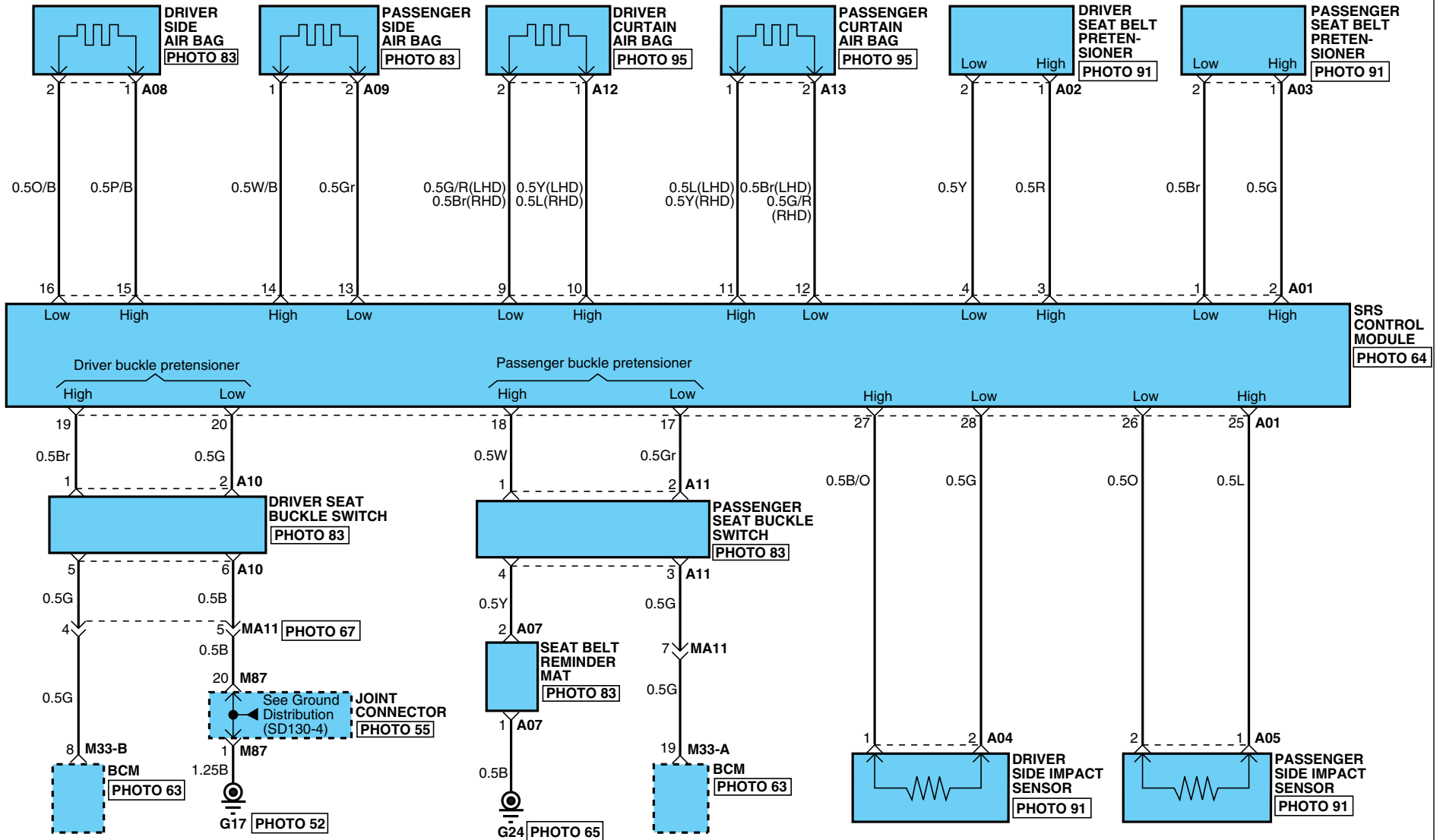

# AIR BAG SYSTEM (SRS)

## AIR BAG SYSTEM (SRS) (3)

SD569-3

**A01**

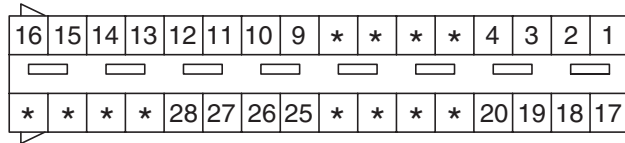

AMP\_ABG\_32F\_B\_ECU

**A02/A03**

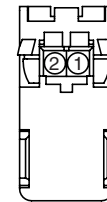

AMP\_ABAG\_02F\_Y

**A04/A05**

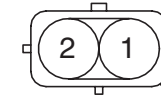

YAZ\_040\_02F\_Y

**A07**

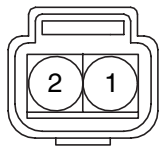

AMP\_MQSWP\_02F\_B

**A08/A09**

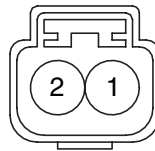

YAZ\_040WP\_02F\_Y\_GH

**A10**

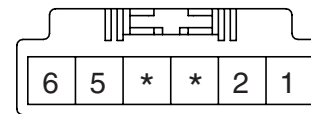

AMP\_ABAG\_06F\_Y

**A11**

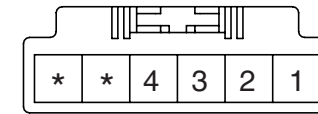

AMP\_ABAG\_06F\_Y

**A12/A13**

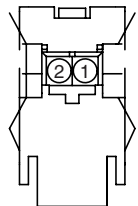

APL\_ABG\_02F\_Y

**BLANK**

**E17**

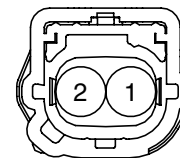

YAZ\_ABAG\_02F\_Y\_B

**E66**

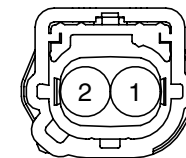

YAZ\_ABAG\_02F\_Y\_B

**M05**

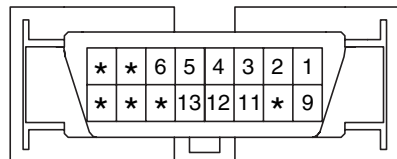

MLX\_OBDII\_16F\_B\_SIN

**M08-2**

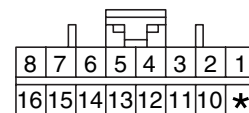

AMP\_040M2\_16F\_B

**M08-3**

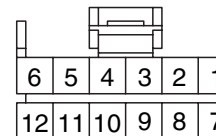

AMP\_040M1\_12F\_B

**M61**

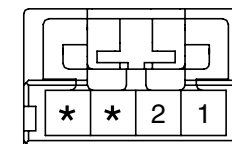

YAZ\_040\_04F\_Y

**M62**



YAZ\_040WP\_02F\_Y\_GH

**M64**

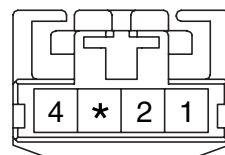

AMP\_MQS\_04F\_Y

**M66**

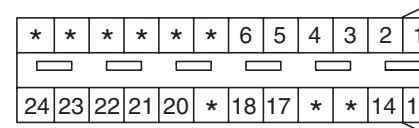

AMP\_ABG\_24F\_B\_ECU

**M93**

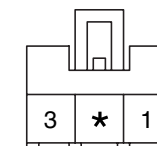

KUM\_CDR\_03F\_W

**AIR BAG SYSTEM (SRS)**

**AIR BAG SYSTEM (SRS) (4)**

**SD569-4**

**MEMO**

AGCS CONTROL SYSTEM (1)

SD583-1

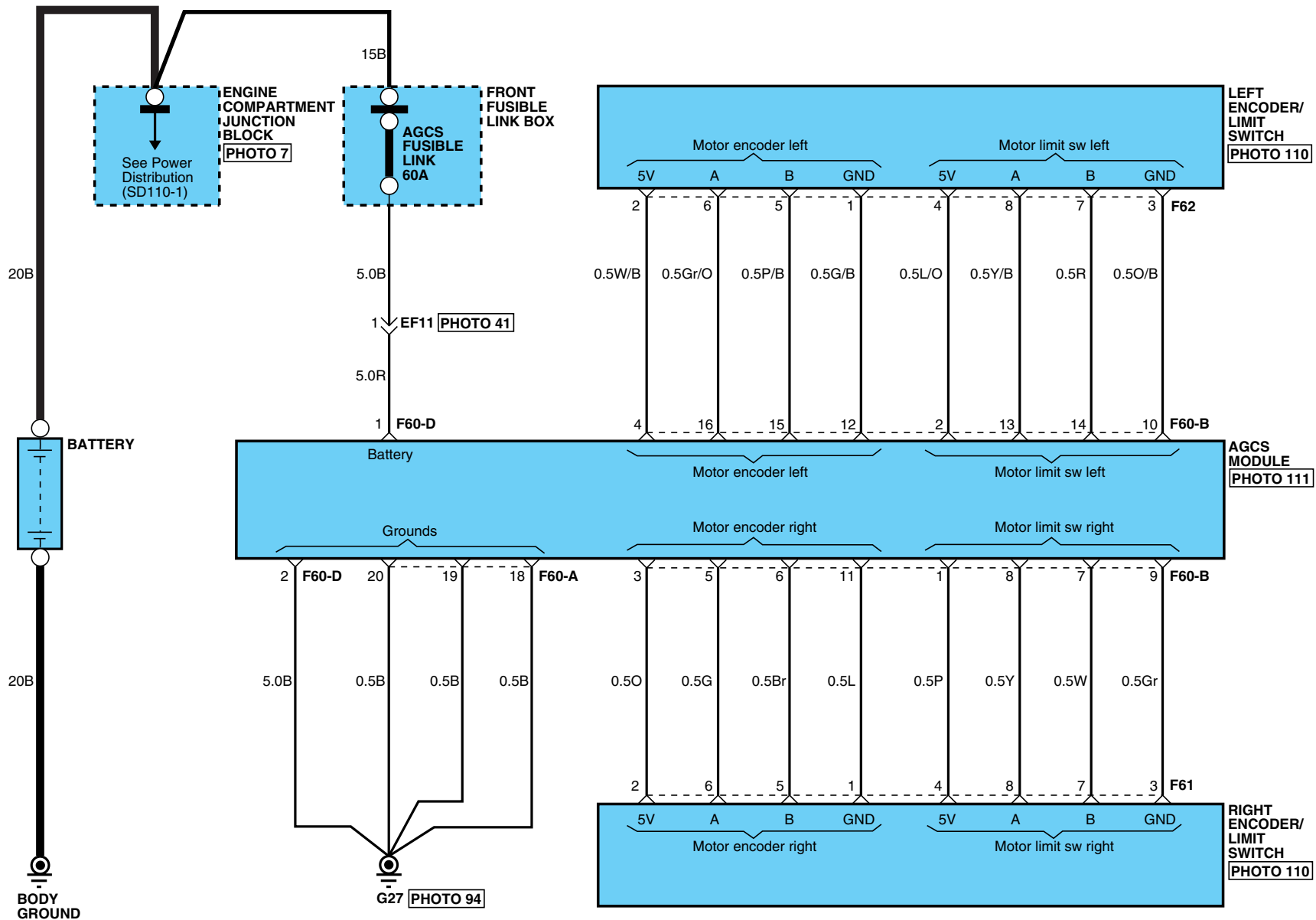

# AGCS CONTROL SYSTEM

## AGCS CONTROL SYSTEM (2)

SD583-2

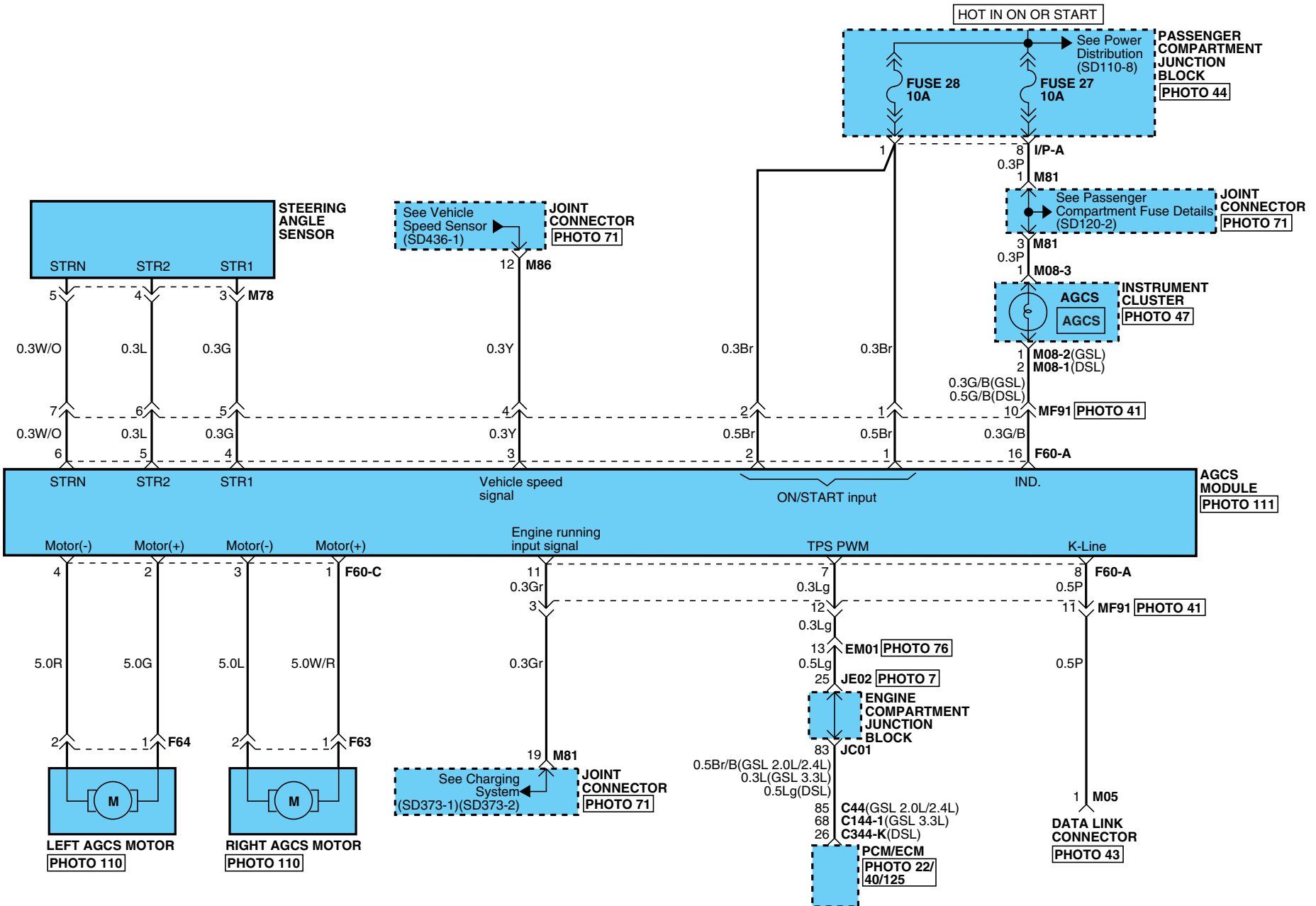

# AGCS CONTROL SYSTEM

## AGCS CONTROL SYSTEM (3)

SD583-3

**F60-A**

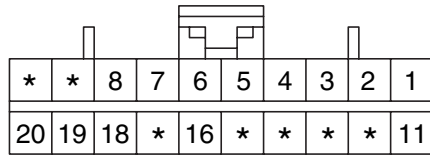

AMP\_040M2\_20F\_B

**F60-B**

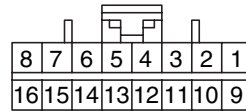

AMP\_040M2\_16F\_B

**F60-C**

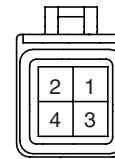

AMP\_MCP\_04F\_B

**F60-D**



AMP\_MCP\_02F\_B

**F61**



AMP\_EJWP\_08F\_Gr

**F62**



AMP\_EJWP\_08F\_B

**F63**

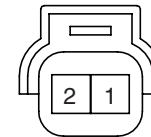

AMP\_312WP\_02F\_Gr

**F64**

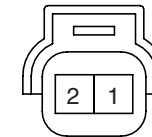

AMP\_312WP\_02F\_B

**M05**

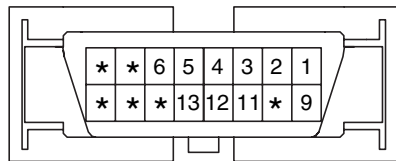

MLX\_OBDII\_16F\_B\_SIN

**M78**

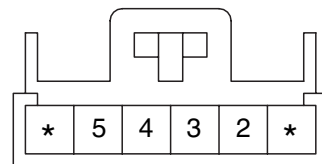

AMP\_070\_06F\_W\_1F

**BLANK**

**BLANK**



**AGCS CONTROL SYSTEM**

**AGCS CONTROL SYSTEM (4)**

**SD583-4**

**MEMO**

ANTI-LOCK BRAKE SYSTEM (ABS) (1)

SD587-1

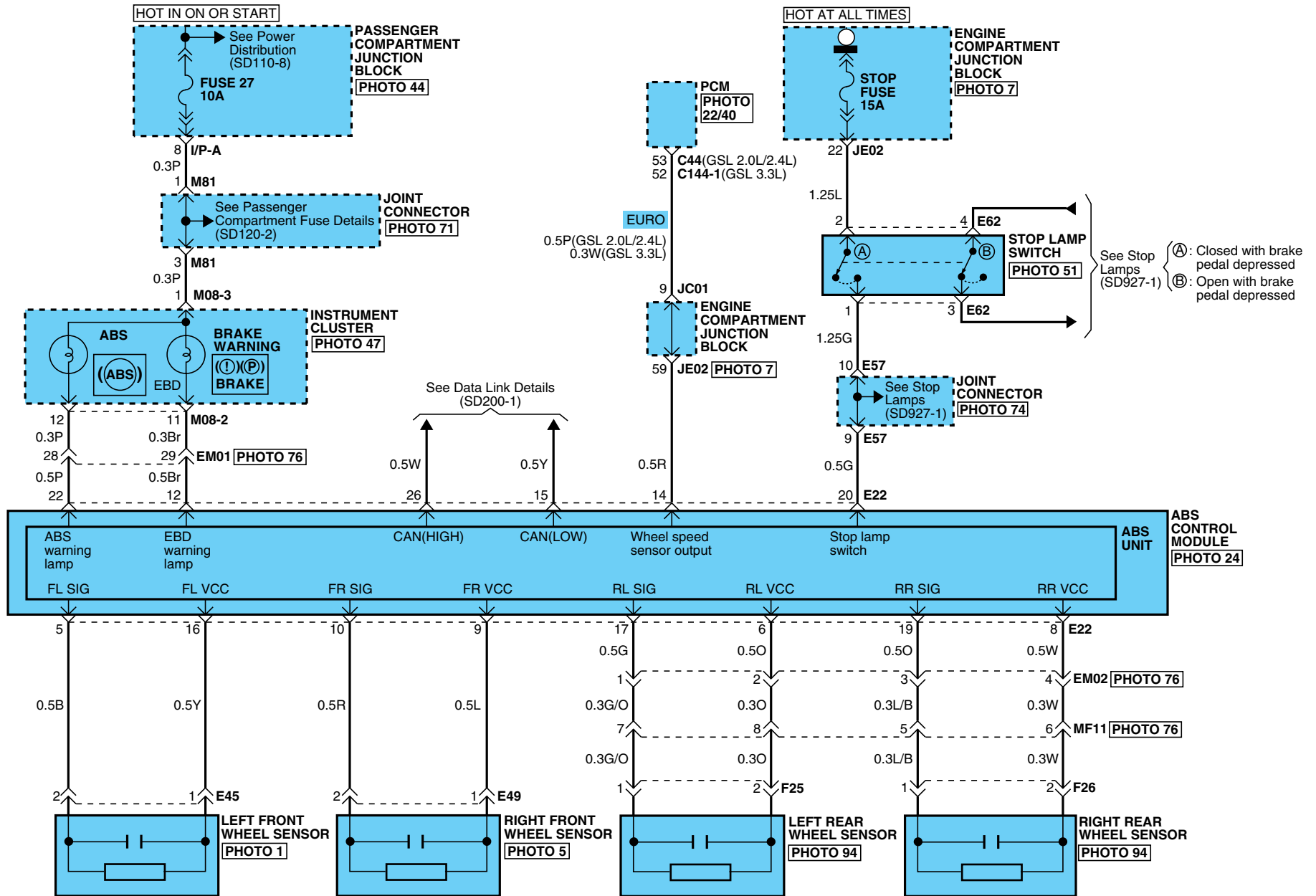

# ANTI-LOCK BRAKE SYSTEM (ABS)

## ANTI-LOCK BRAKE SYSTEM (ABS) (2)

SD587-2

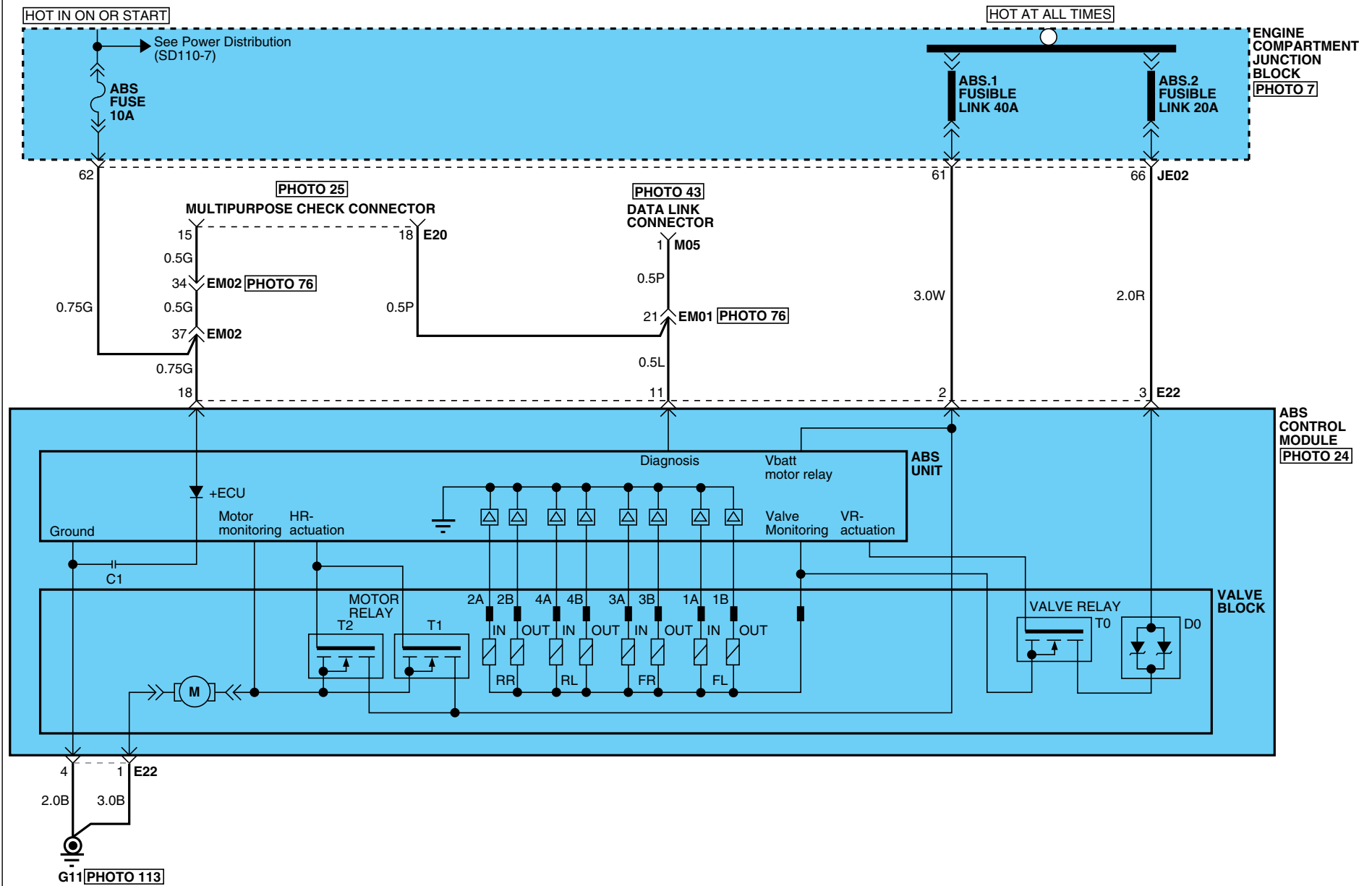

# ANTI-LOCK BRAKE SYSTEM (ABS)

## ANTI-LOCK BRAKE SYSTEM (ABS) (3)

SD587-3

**E20**

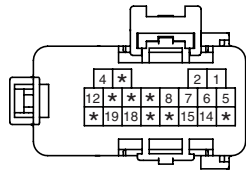

KET\_DIAG\_20F\_B\_BRK\_A

**E22**

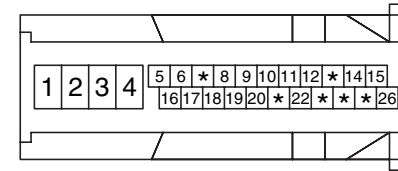

BOS\_ABS\_26F\_B\_L

**E45**

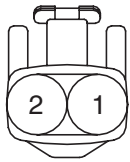

KET\_090IWP\_02F\_B

**E49**

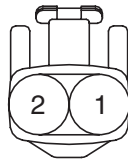

KET\_090IWP\_02F\_B

**E62**

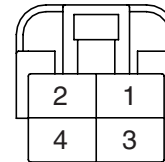

KET\_250DL\_04F\_W

**BLANK**

**F25**

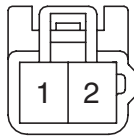

YAZ\_090II\_02M\_W\_L

**F26**

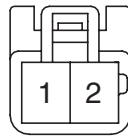

YAZ\_090II\_02M\_W\_L

**M05**

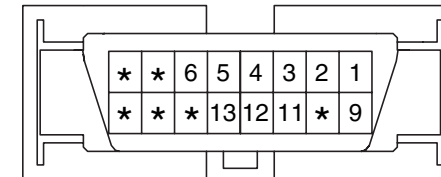

MLX\_OBDII\_16F\_B\_SIN

**M08-2**

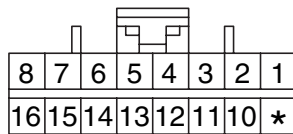

AMP\_040M2\_16F\_B

**M08-3**

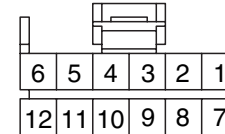

AMP\_040M1\_12F\_B

**BLANK**

**ANTI-LOCK BRAKE SYSTEM (ABS)**

**ANTI-LOCK BRAKE SYSTEM (ABS) (4)**

**SD587-4**

**MEMO**

ELECTRONIC STABILITY PROGRAM (ESP) SYSTEM (1)

SD589-1

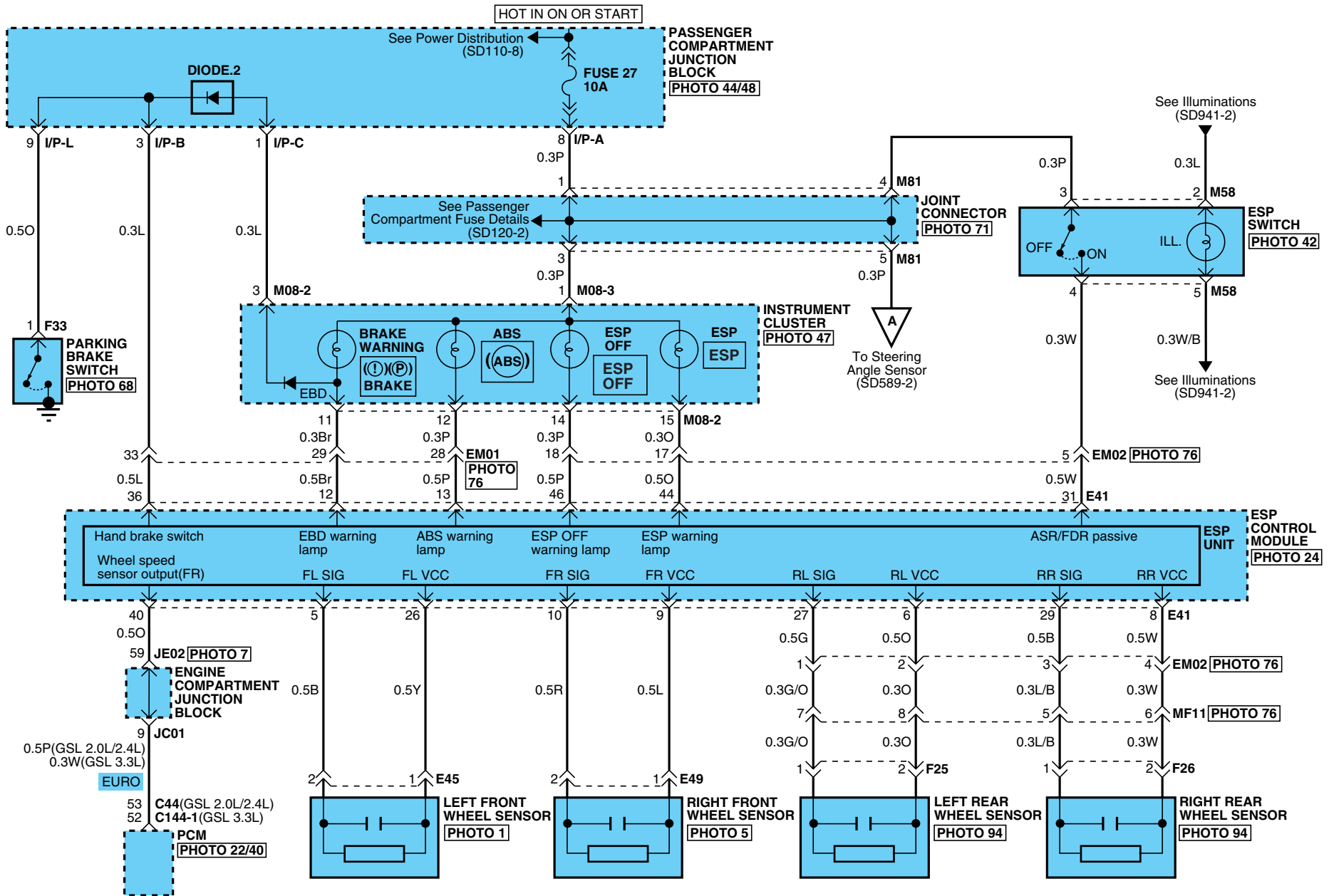

# ELECTRONIC STABILITY PROGRAM (ESP) SYSTEM

## ELECTRONIC STABILITY PROGRAM (ESP) SYSTEM (2)

SD589-2

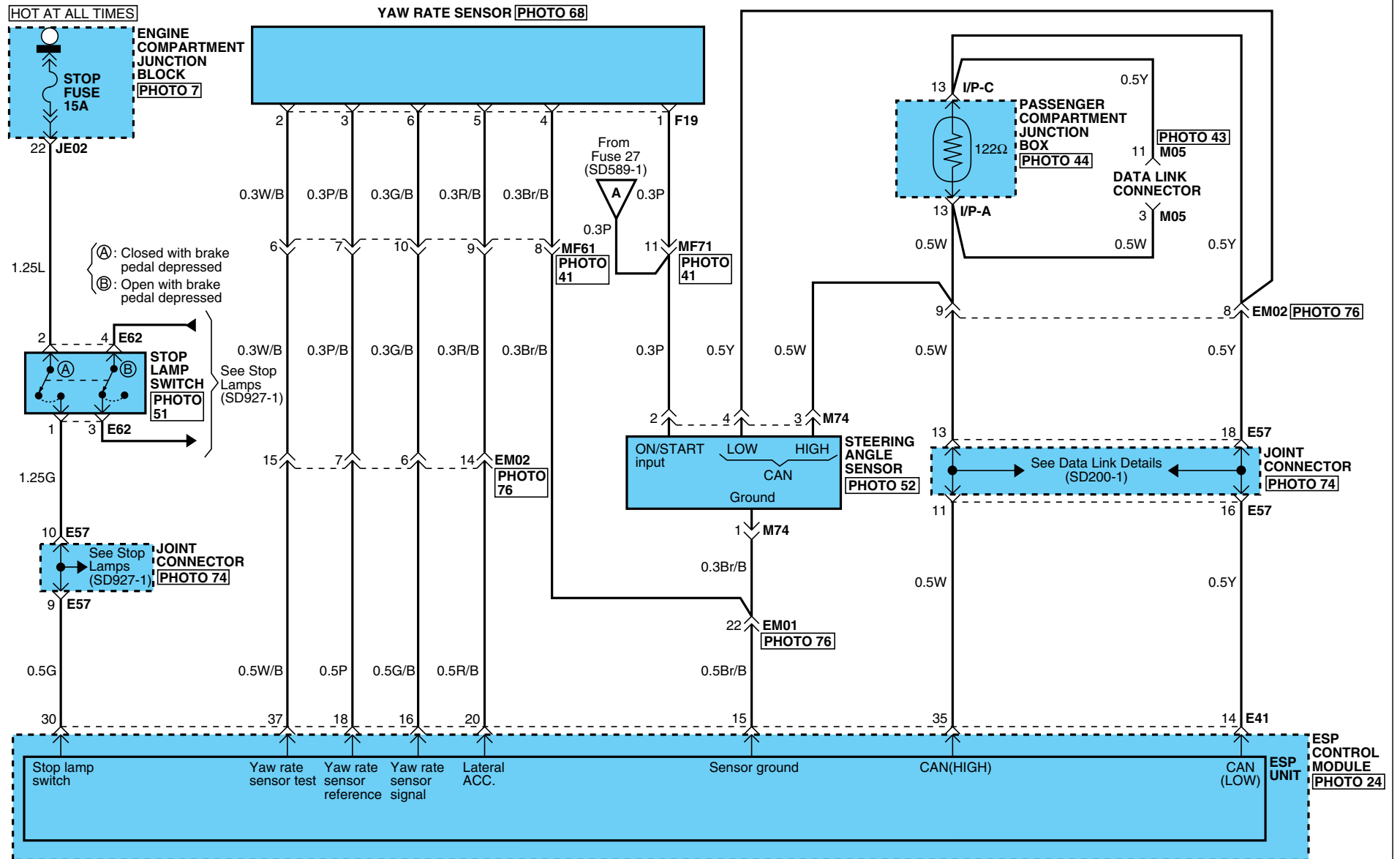

# ELECTRONIC STABILITY PROGRAM (ESP) SYSTEM

## ELECTRONIC STABILITY PROGRAM (ESP) SYSTEM (3)

SD589-3

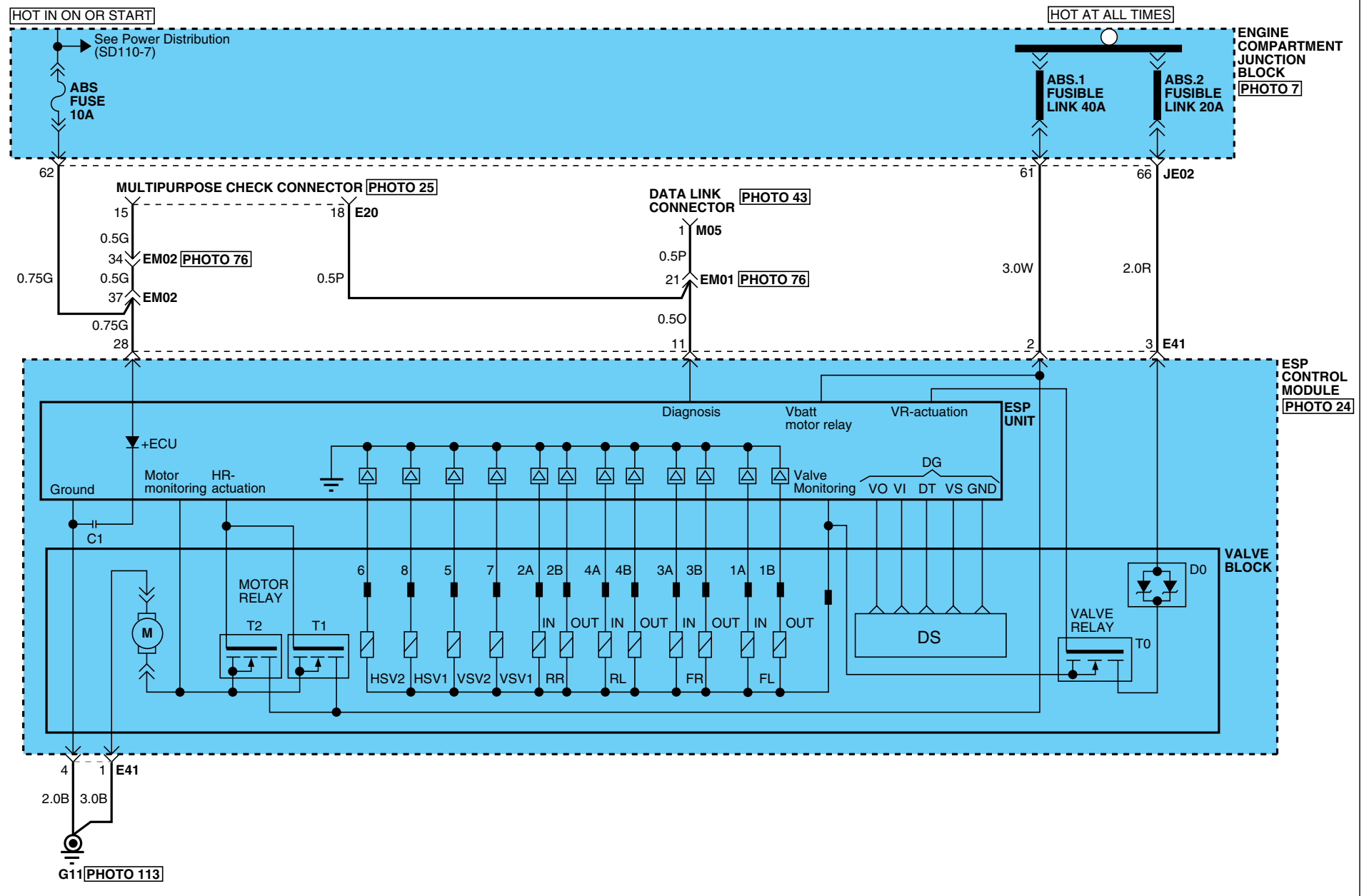



# ELECTRONIC STABILITY PROGRAM (ESP) SYSTEM

## ELECTRONIC STABILITY PROGRAM (ESP) SYSTEM (4)

SD589-4

**E20**

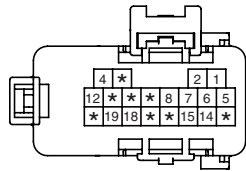

KET\_DIAG\_20F\_B\_BRK\_A

**E41**

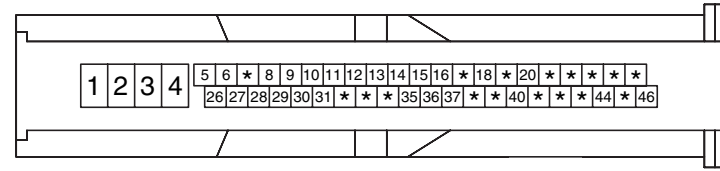

BOS\_ESP\_46F\_B\_L

**E45**

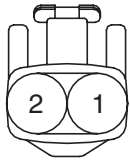

KET\_090IWP\_02F\_B

**E49**

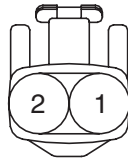

KET\_090IWP\_02F\_B

**E62**

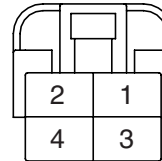

KET\_250DL\_04F\_W

**F19**

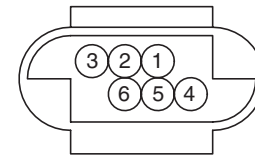

AMP\_MQSWP\_06F\_B\_1

**F25**

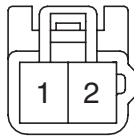

YAZ\_090II\_02M\_W\_L

**F26**

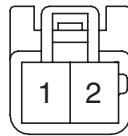

YAZ\_090II\_02M\_W\_L

**F33**

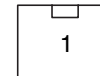

AMP\_PLM1\_01F\_B

**BLANK**

**M05**

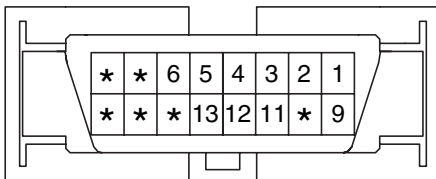

MLX\_OBDII\_16F\_B\_SIN

**M08-2**

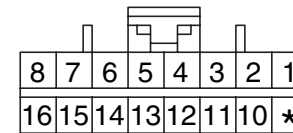

AMP\_040M2\_16F\_B

**M08-3**

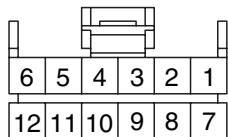

AMP\_040M1\_12F\_B

**M58**

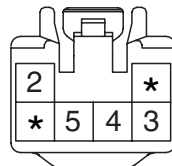

KET\_090III\_06F\_G

**M74**

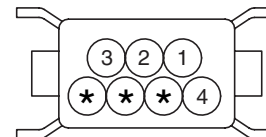

BSH\_040\_07F\_B

**BLANK**

FUEL FILLER DOOR & TRUNK LID OPENER (1)

SD812-1

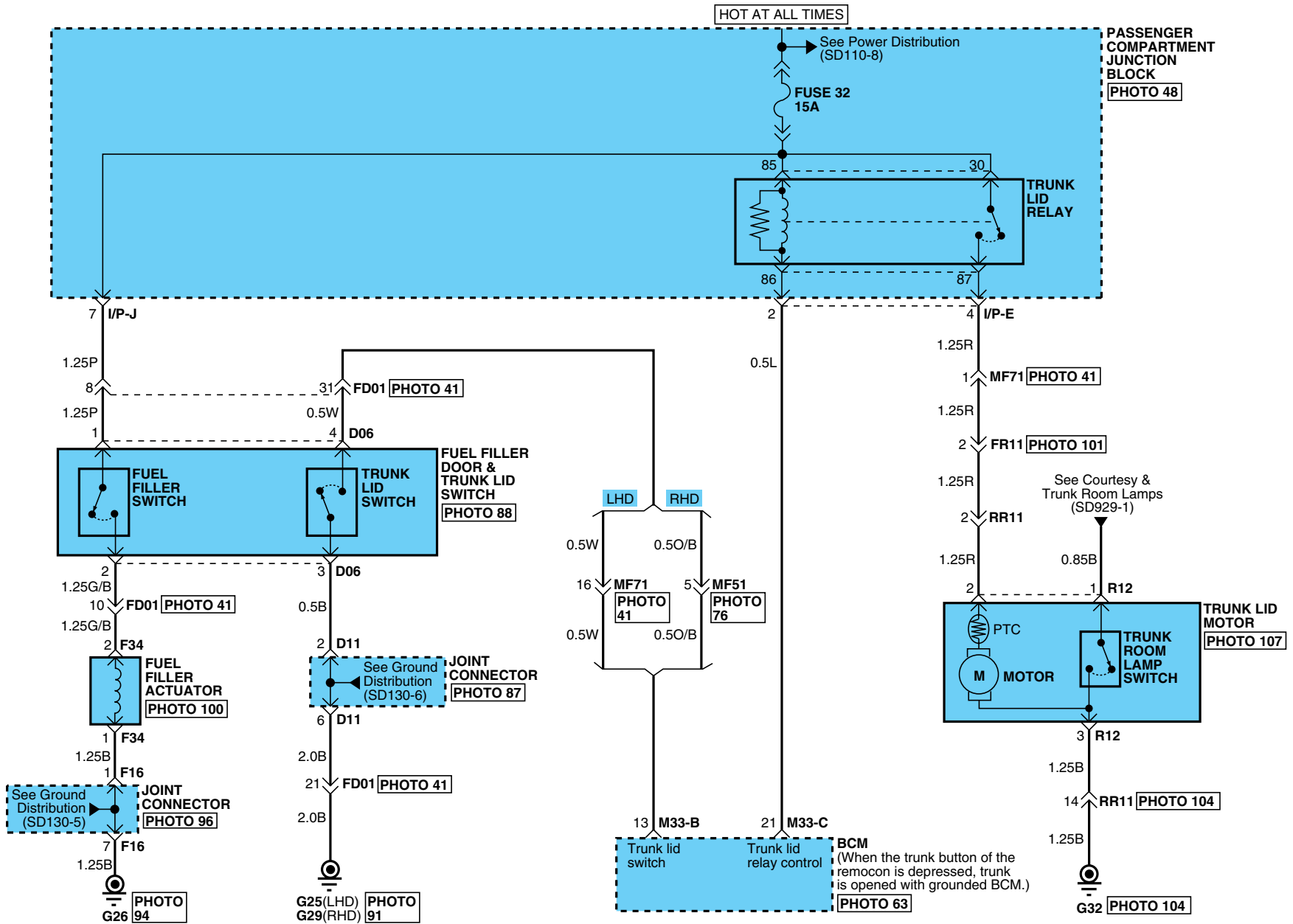

# FUEL FILLER DOOR & TRUNK LID OPENER

## FUEL FILLER DOOR & TRUNK LID OPENER (2)

SD812-2

**D06**

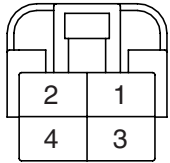

KET\_250DL\_04F\_W

**F34**



KET\_250\_02F\_W

**M33-B**

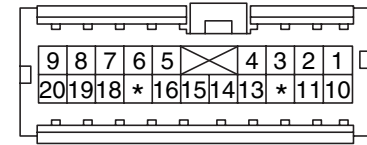

AMP\_040III\_20F\_W

**M33-C**

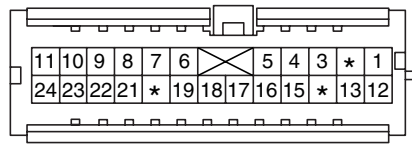

AMP\_040III\_24F\_GR

**R12**

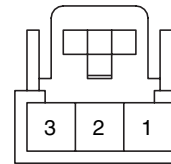

AMP\_070\_03F\_W

**BLANK**

POWER DOOR LOCKS (1)

SD813-1

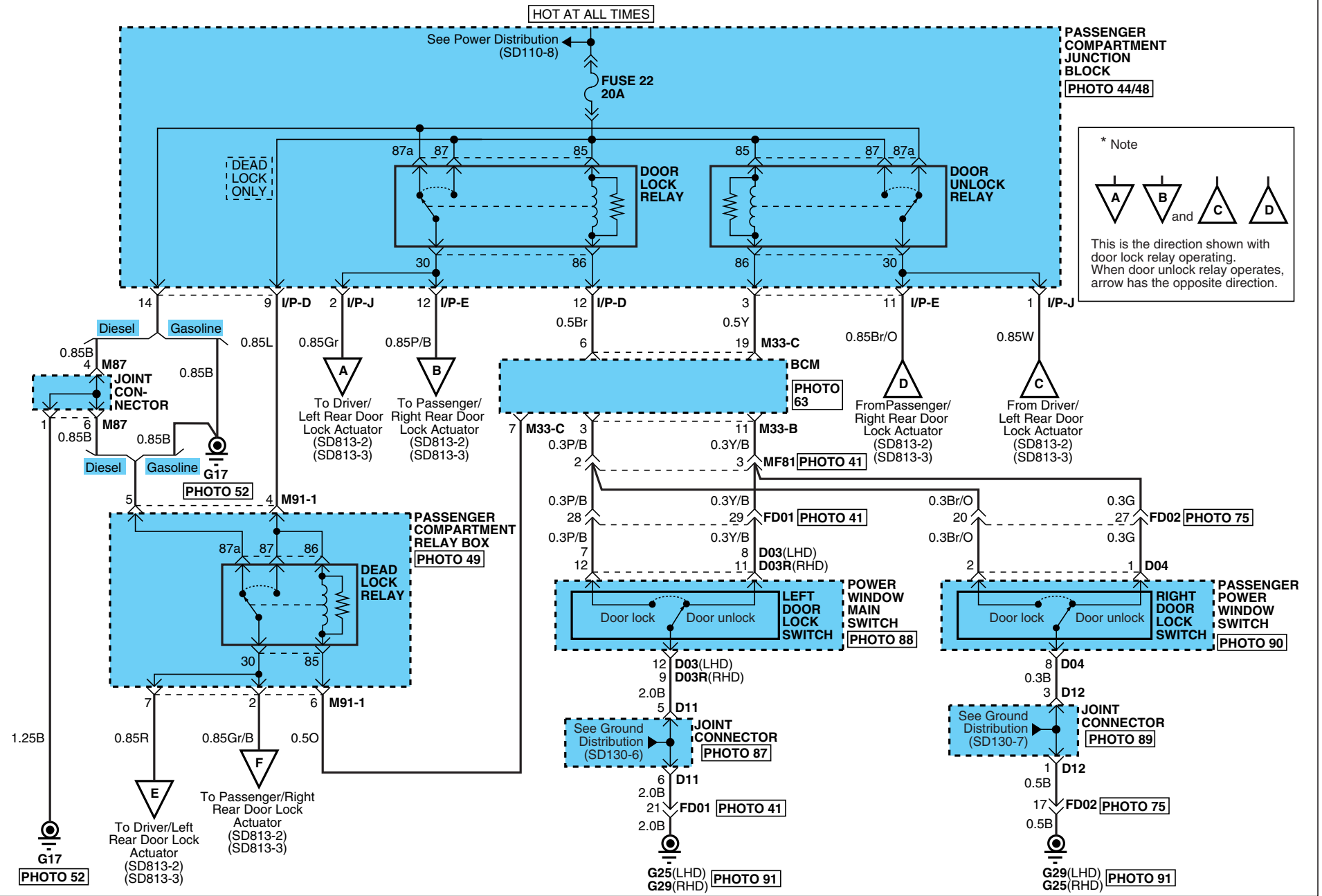

# POWER DOOR LOCKS

## POWER DOOR LOCKS (2)

SD813-2

**LHD**

BCM  
PHOTO 63

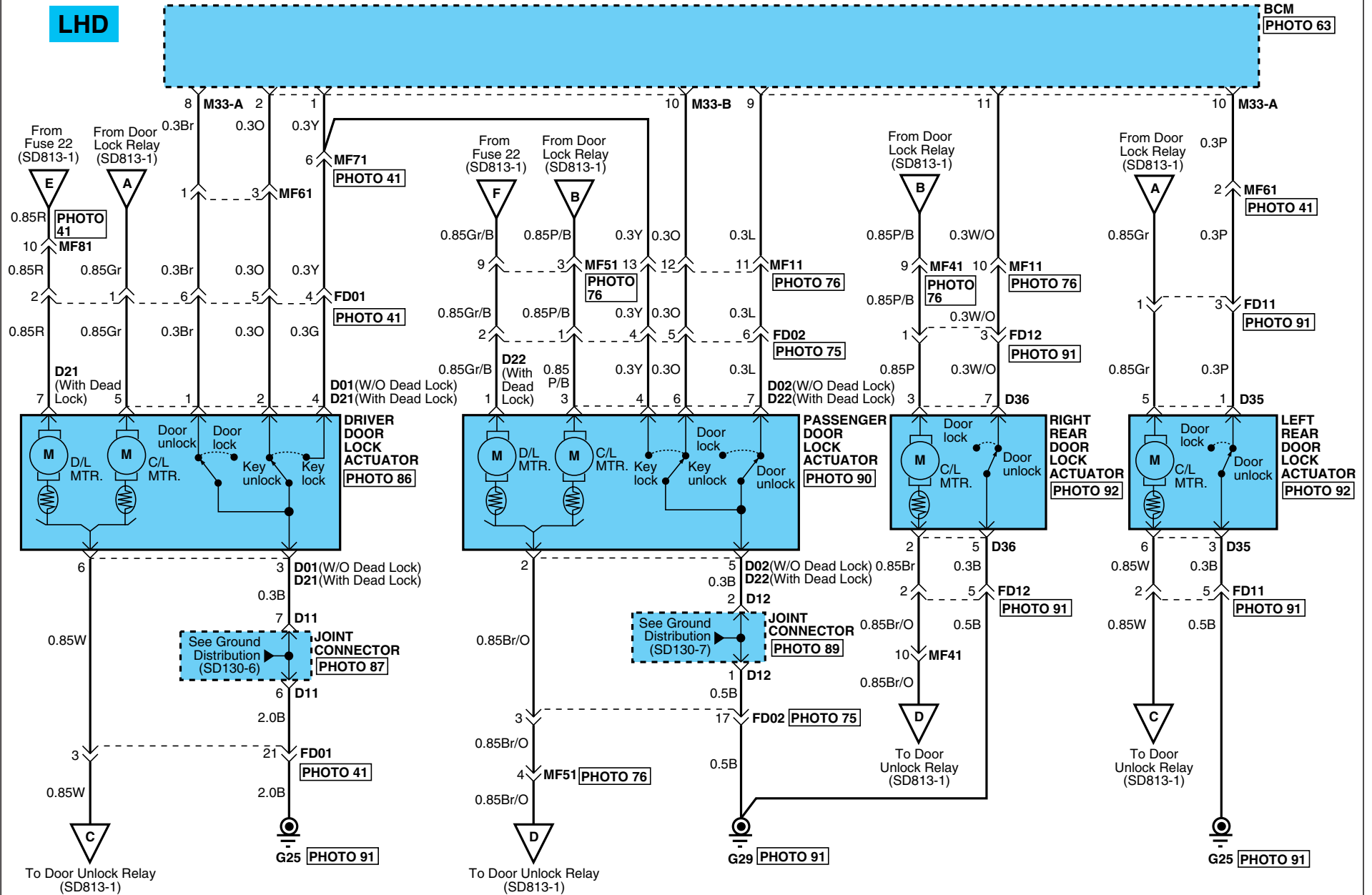

# POWER DOOR LOCKS

## POWER DOOR LOCKS (3)

SD813-3

RHD

BCM  
PHOTO 63

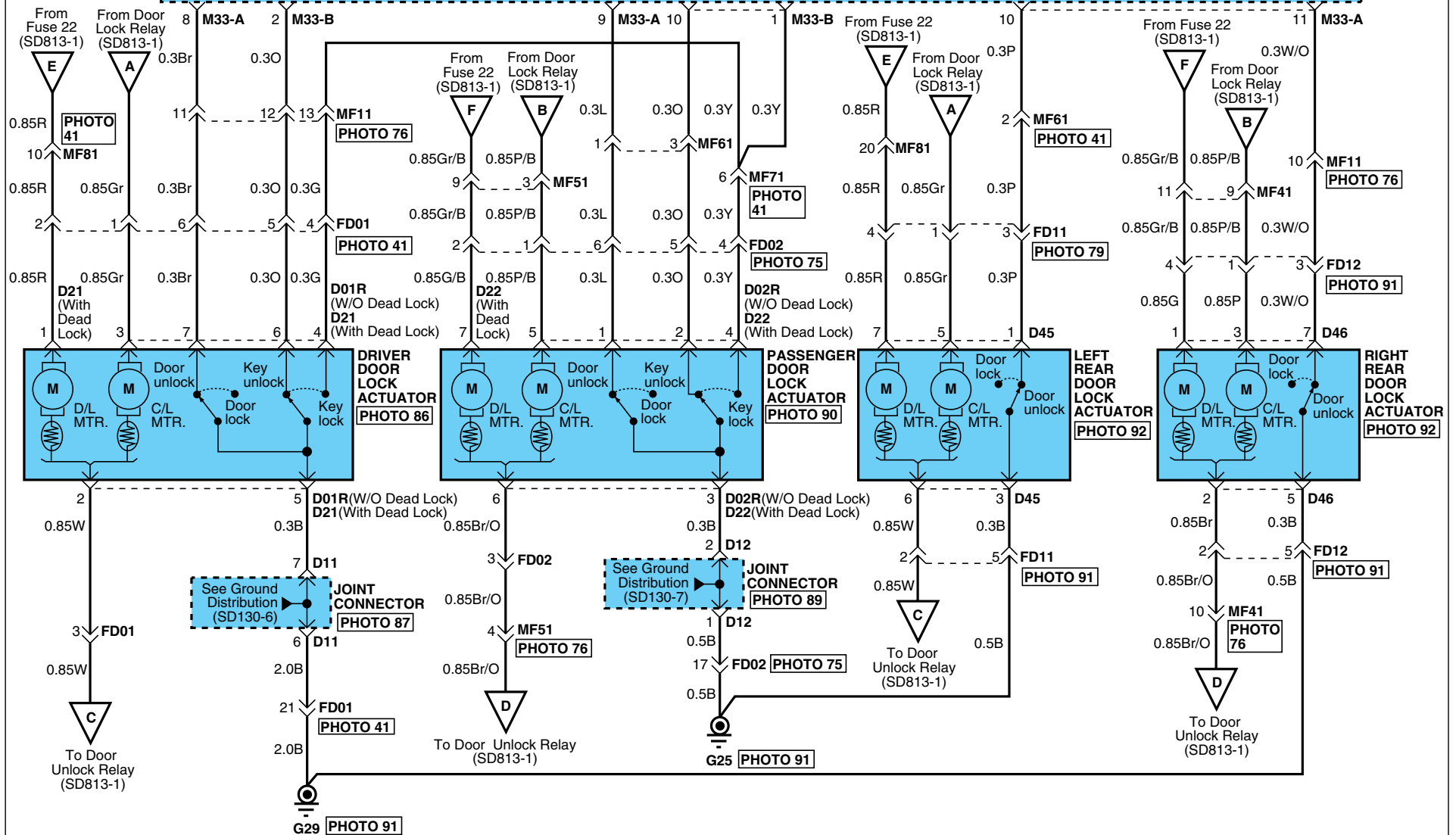

# POWER DOOR LOCKS

## POWER DOOR LOCKS (4)

SD813-4

**D01**

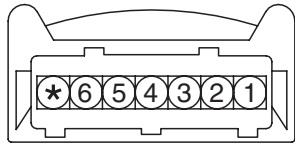

AMP\_110WP\_07F\_B\_DR

**D01R**

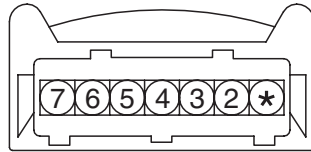

AMP\_110WP\_07F\_B\_DR

**D02**

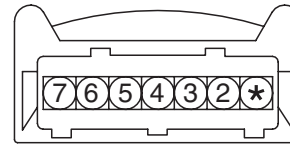

AMP\_110WP\_07F\_B\_DR

**D02R**

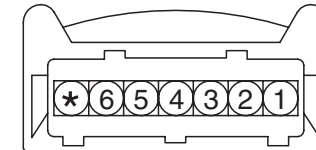

AMP\_110WP\_07F\_B\_DR

**D03/D03R**

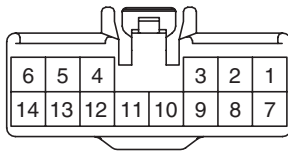

KET\_090III\_14F\_W

**D04**

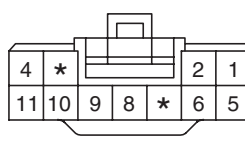

KET\_090II\_11F\_W

**D21**

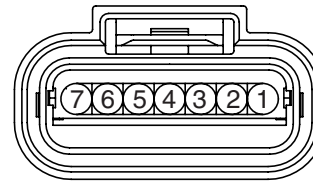

AMP\_025WP\_07F\_B

**D22**

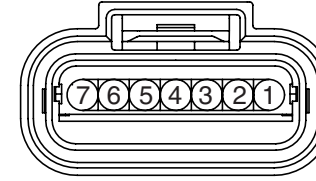

AMP\_025WP\_07F\_B

**D35**

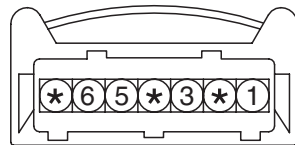

AMP\_110WP\_07F\_B\_DR

**D36**

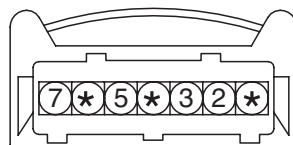

AMP\_110WP\_07F\_B\_DR

**D45**

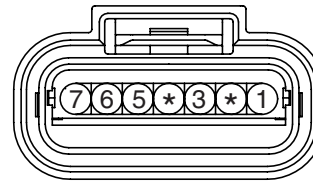

AMP\_025WP\_07F\_B

**D46**

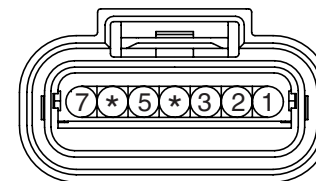

AMP\_025WP\_07F\_B

**M33-A**

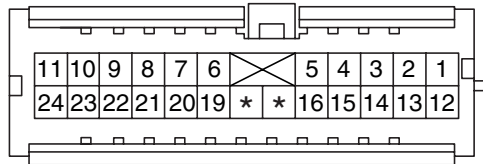

AMP\_040III\_24F\_W

**M33-B**

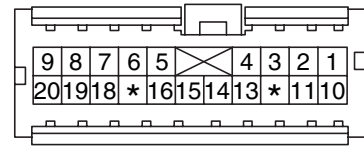

AMP\_040III\_20F\_W

**BLANK**

**M33-C**

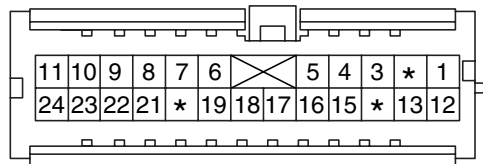

AMP\_040III\_24F\_GR

**M91-1**

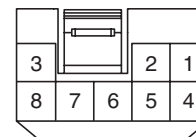

AMP\_090III\_08F\_W

**BLANK**

KEYLESS ENTRY & BURGLAR ALARM SYSTEM (1)

SD814-1

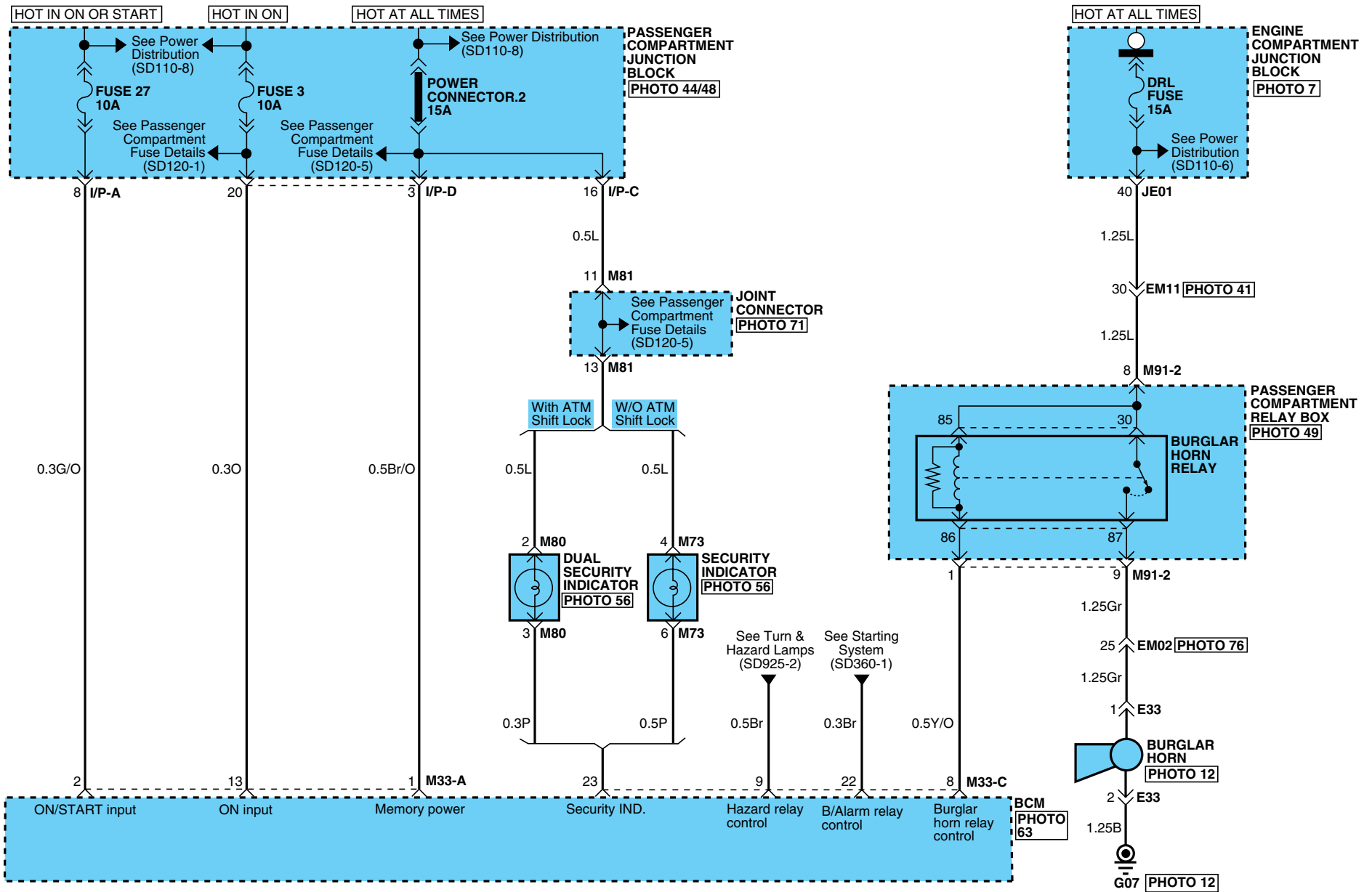



# KEYLESS ENTRY & BURGLAR ALARM SYSTEM

## KEYLESS ENTRY & BURGLAR ALARM SYSTEM (2)

SD814-2

**LHD**

BCM  
PHOTO 63

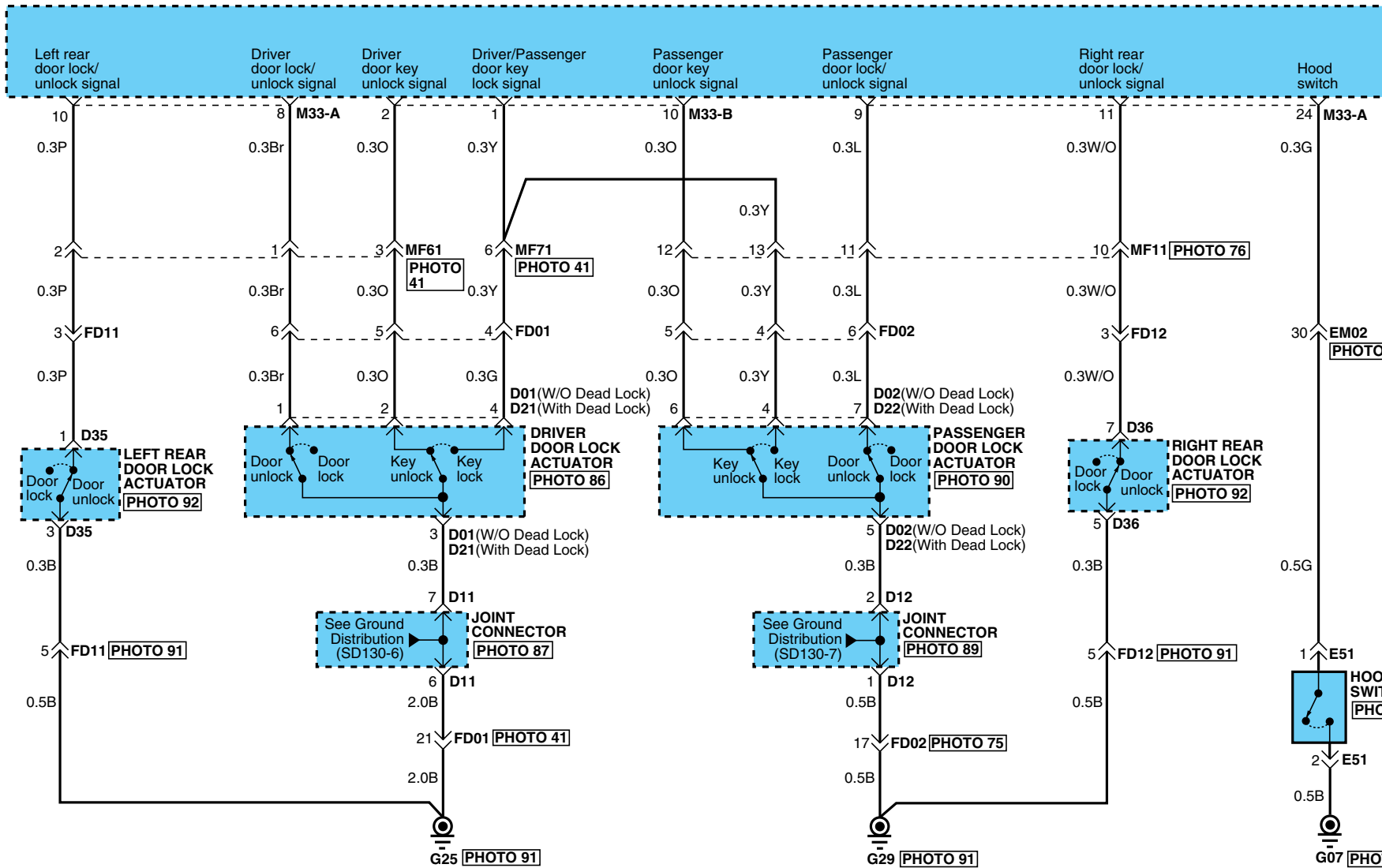

# KEYLESS ENTRY & BURGLAR ALARM SYSTEM

## KEYLESS ENTRY & BURGLAR ALARM SYSTEM (3)

SD814-3

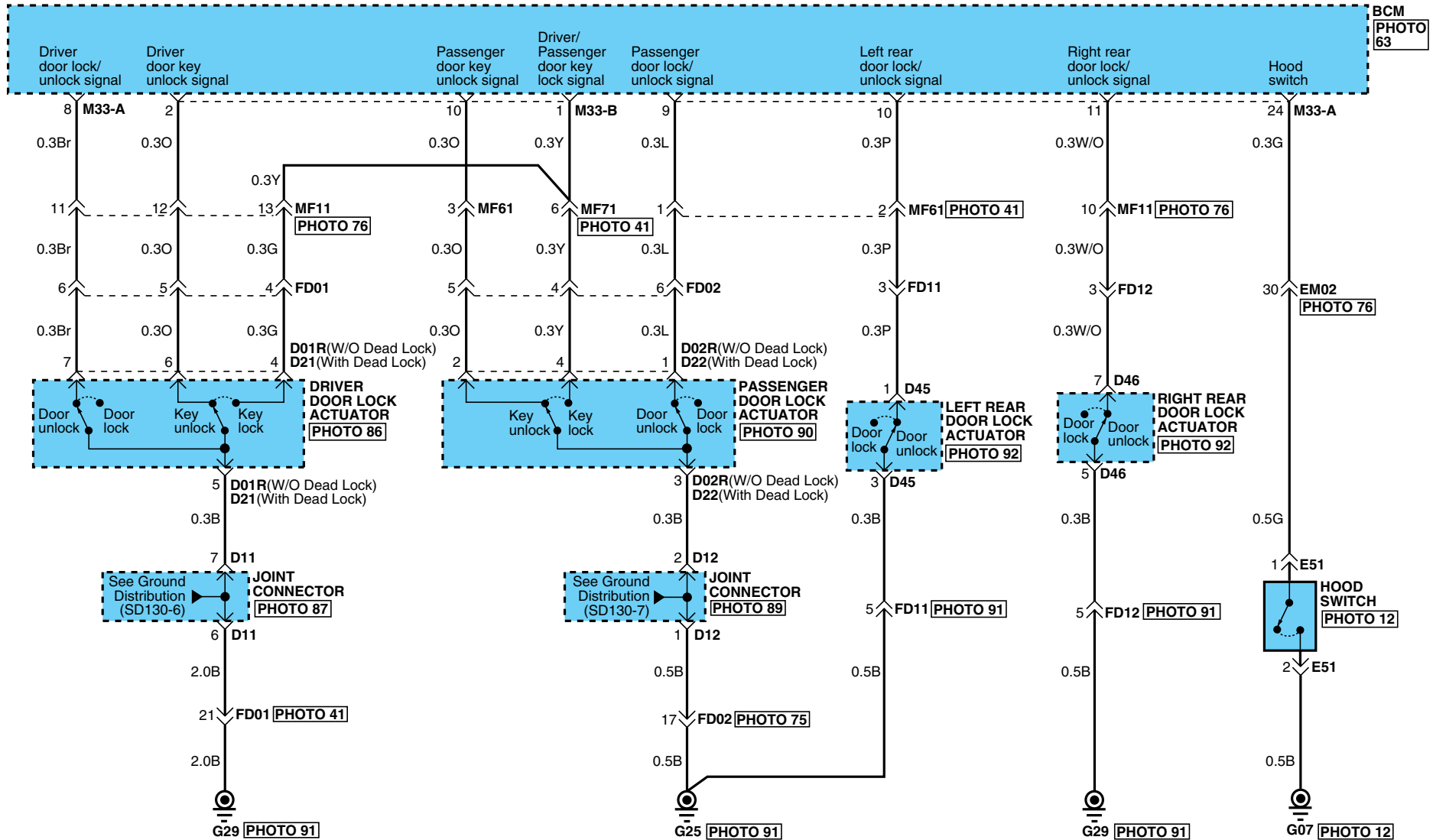

**RHD**



**KEYLESS ENTRY & BURGLAR ALARM SYSTEM**

**KEYLESS ENTRY & BURGLAR ALARM SYSTEM (4)**

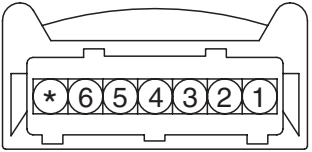
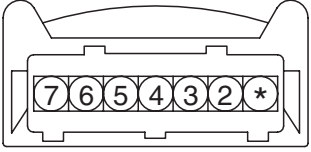
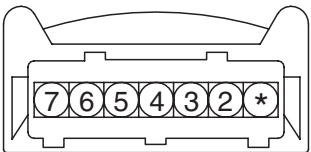
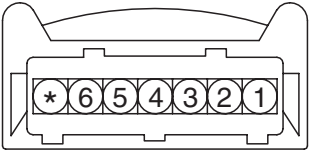
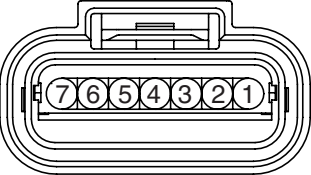
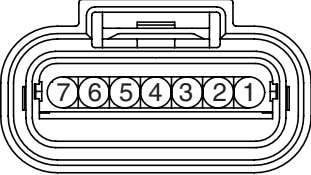
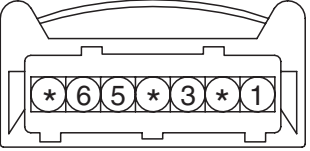
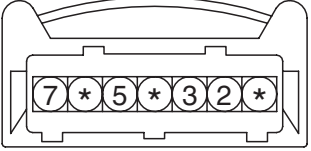
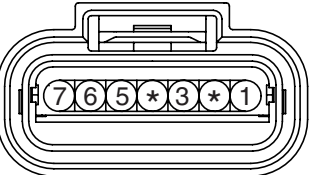
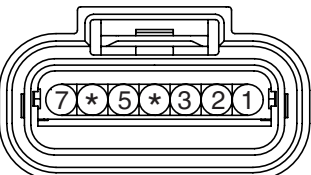
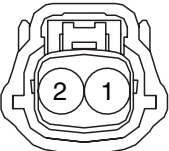
**SD814-4**

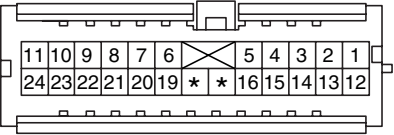
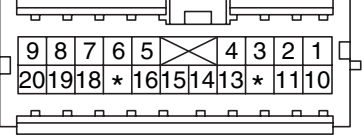
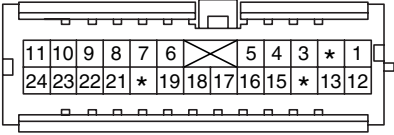
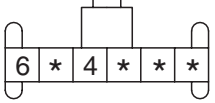
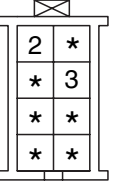
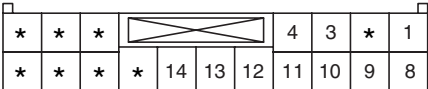
<p><b>D01</b></p>  <p>AMP_110WP_07F_B_DR</p>	<p><b>D01R</b></p>  <p>AMP_110WP_07F_B_DR</p>	<p><b>D02</b></p>  <p>AMP_110WP_07F_B_DR</p>	<p><b>D02R</b></p>  <p>AMP_110WP_07F_B_DR</p>
<p><b>D21</b></p>  <p>AMP_025WP_07F_B</p>	<p><b>D22</b></p>  <p>AMP_025WP_07F_B</p>	<p><b>D35</b></p>  <p>AMP_110WP_07F_B_DR</p>	<p><b>D36</b></p>  <p>AMP_110WP_07F_B_DR</p>
<p><b>D45</b></p>  <p>AMP_025WP_07F_B</p>	<p><b>D46</b></p>  <p>AMP_025WP_07F_B</p>	<p><b>E33</b></p>  <p>MLX_HORN_02F_B_FILT</p>	<p><b>E51</b></p>  <p>KET_090IWP_02F_B_FA</p>
<p><b>M33-A</b></p>  <p>AMP_040III_24F_W</p>	<p><b>M33-B</b></p>  <p>AMP_040III_20F_W</p>	<p><b>M33-C</b></p>  <p>AMP_040III_24F_GR</p>	<p><b>M73</b></p>  <p>YAZ_91A_06F_W</p>
<p><b>M80</b></p>  <p>KET_030_08F_GR</p>	<p><b>M91-2</b></p>  <p>AMP_0925_18F_W</p>	<p><b>BLANK</b></p>	<p><b>BLANK</b></p>

SUNROOF (1)

SD816-1

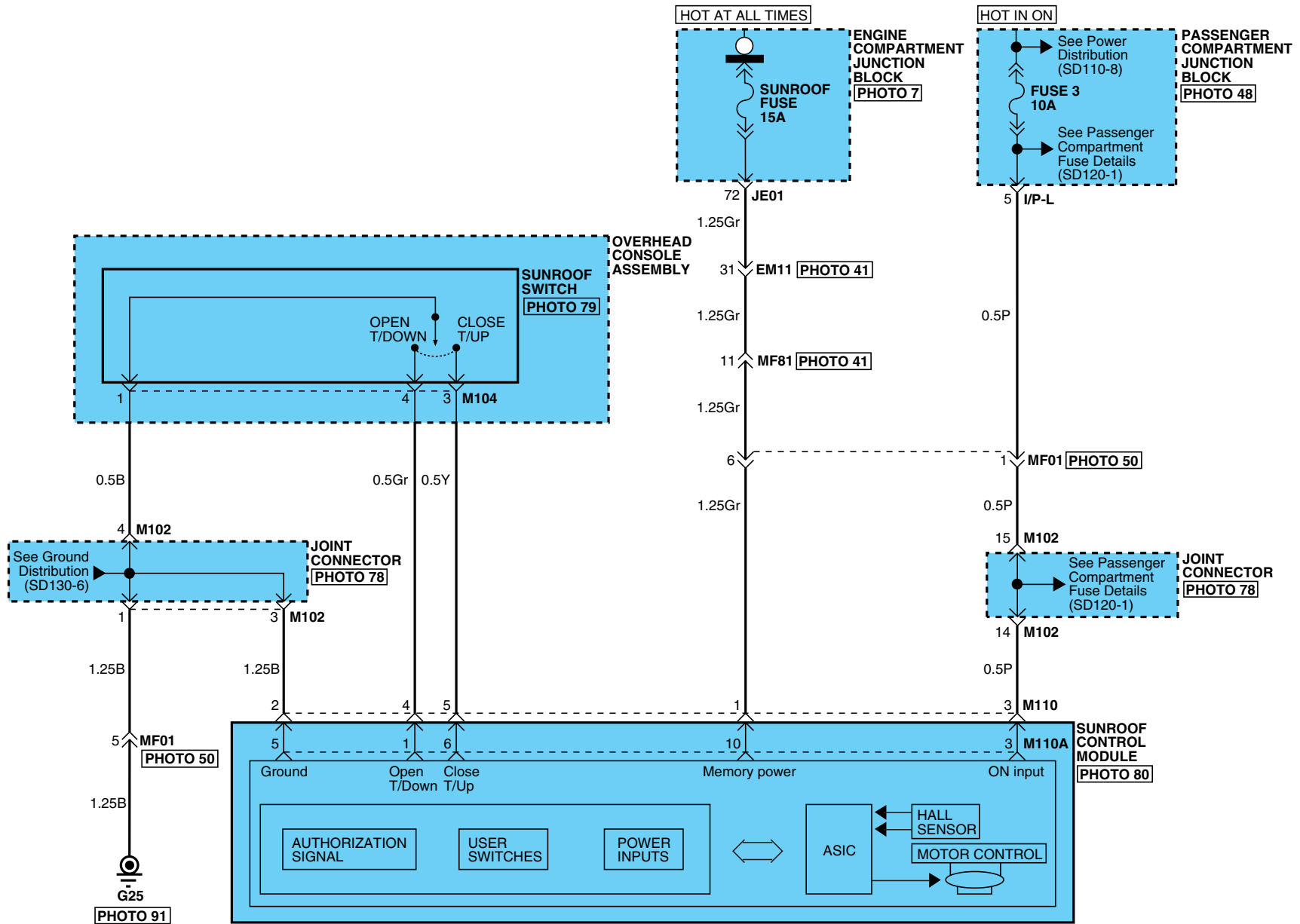

# SUNROOF

## SUNROOF (2)

SD816-2

M104

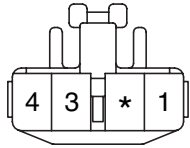

KET\_090III\_04F\_W

M110

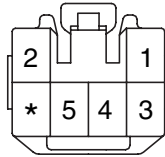

KET\_090II\_06F\_W

M110A

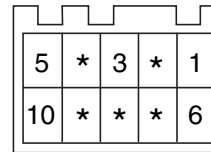

CR10F035

BLANK

POWER WINDOWS (1)

SD824-1

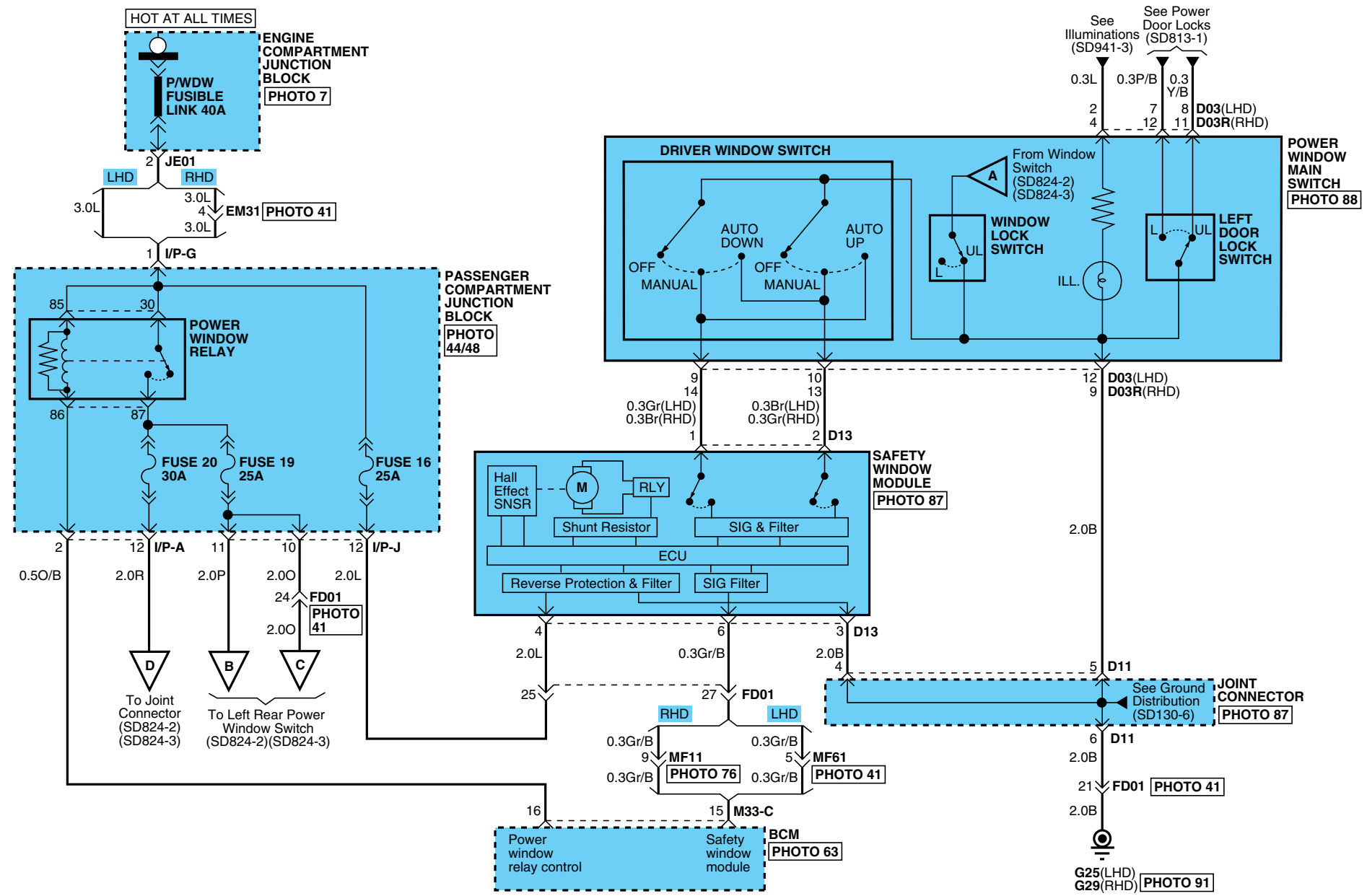

# POWER WINDOWS

## POWER WINDOWS (2)

SD824-2

**LHD**

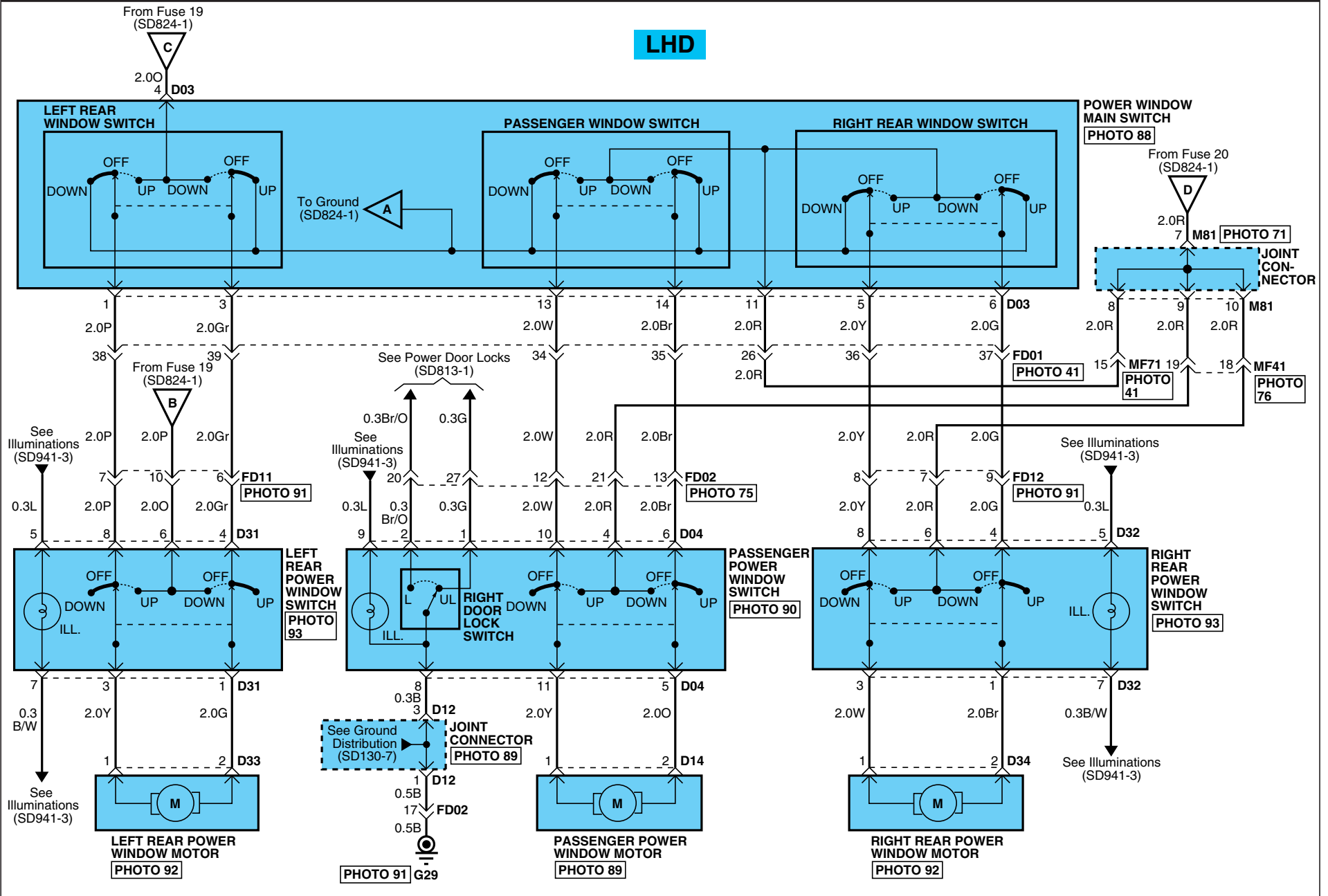

# POWER WINDOWS

## POWER WINDOWS (3)

SD824-3

**RHD**

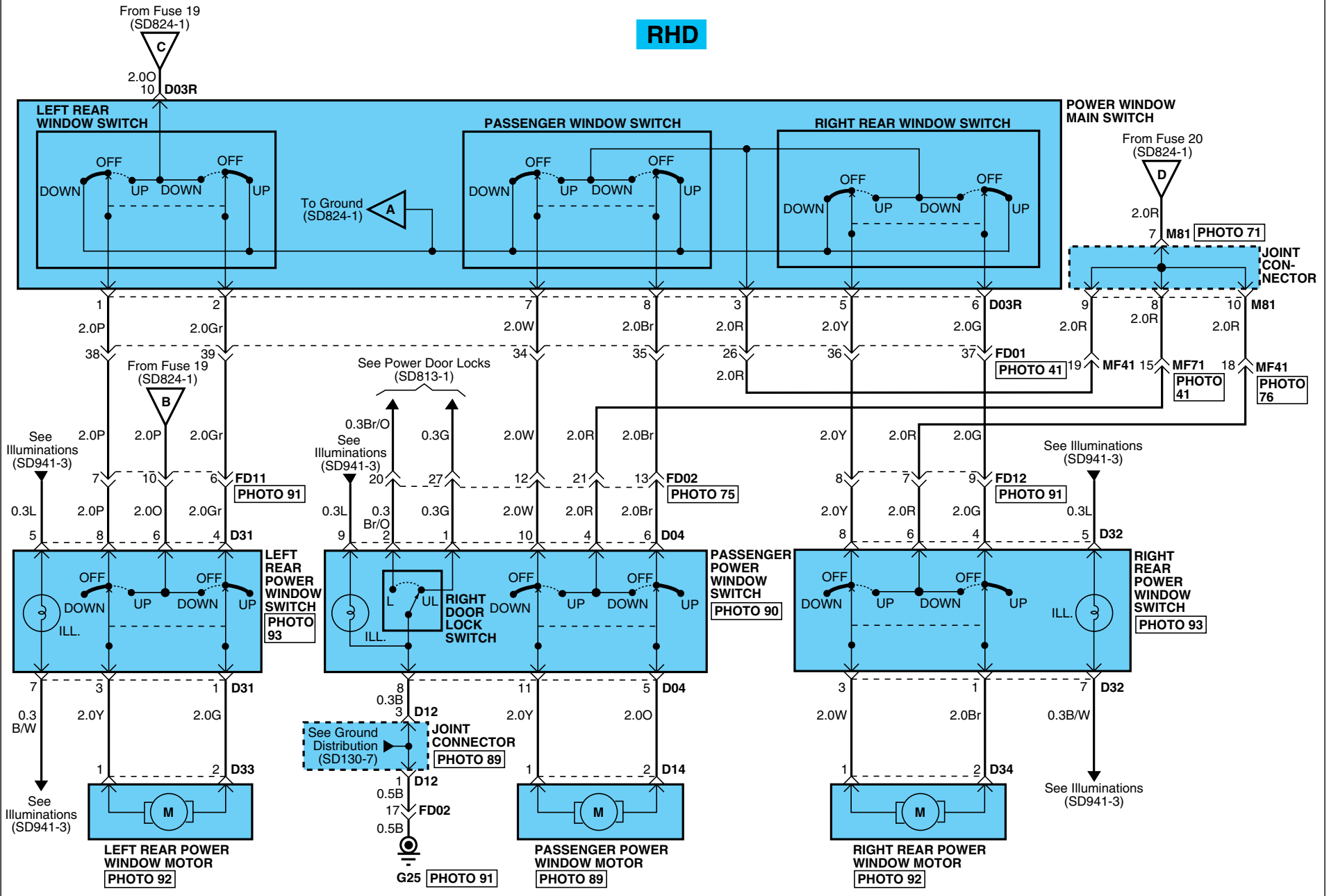



**POWER WINDOWS**

**POWER WINDOWS (4)**

**SD824-4**

**D03/D03R**

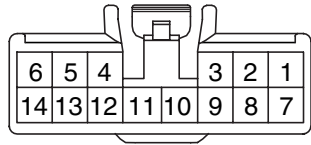

KET\_090III\_14F\_W

**D04**

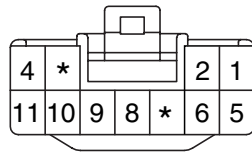

KET\_090II\_11F\_W

**D13**

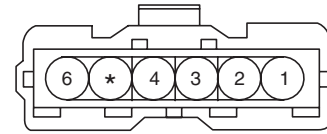

FCI\_SENSOR\_06F\_B

**D14**

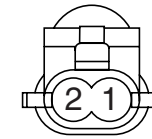

FCI\_SENSOR\_02F

**D31**

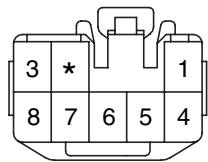

KET\_090III\_08F\_W

**D32**

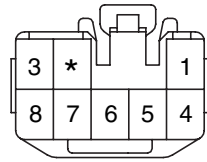

KET\_090III\_08F\_W

**D33**

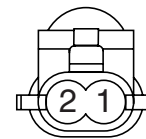

FCI\_SENSOR\_02F

**D34**

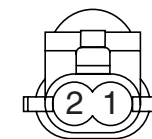

FCI\_SENSOR\_02F

**M33-C**

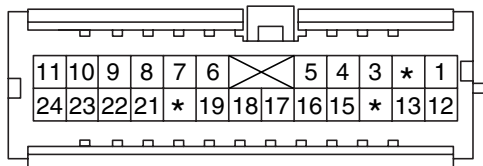

AMP\_040III\_24F\_GR

**BLANK**

**BLANK**

ELECTRO CHROME MIRROR (1)

SD851-1

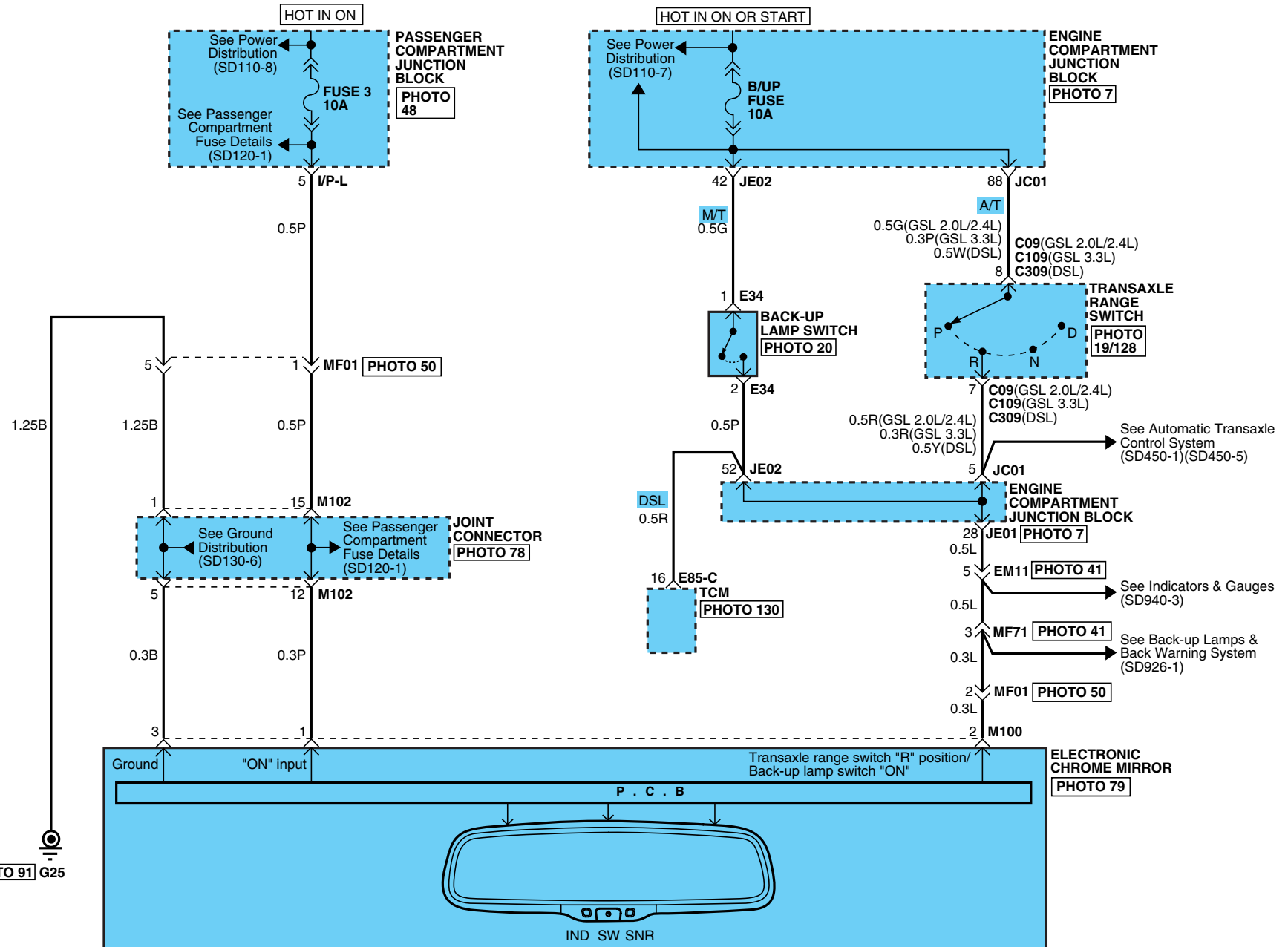

# ELECTRO CHROME MIRROR

## ELECTRO CHROME MIRROR (2)

SD851-2

C09/C109



KET\_SSD\_10F\_B\_A

C309

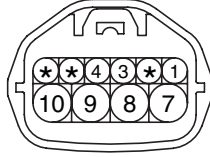

KET\_SSD\_10F\_B\_A

E34

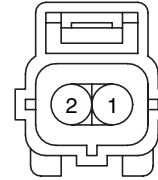

AMP\_EJWP\_02F\_B

M100

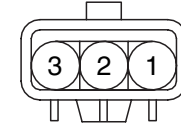

KET\_TLCWP\_03F\_W

POWER OUTSIDE MIRRORS (1)

SD876-1

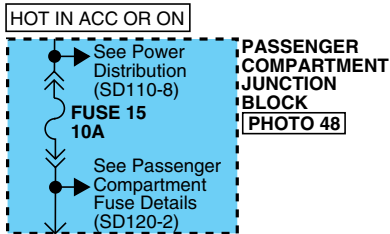

**TABLE**

MIRROR SELECT SWITCH	SELECTOR SWITCH POSITION	POSITION	Pin No. ( ):RHD						
			7 (1)	8 (4)	1 (7)	4 (8)	5	3	6
LEFT	UP	UP	○	○	○	○	○	○	○
	DOWN	DOWN	○	○	○	○	○	○	○
	OFF	OFF	○	○	○	○	○	○	○
RIGHT	UP	UP	○	○	○	○	○	○	○
	DOWN	DOWN	○	○	○	○	○	○	○
	OFF	OFF	○	○	○	○	○	○	○
	LEFT	LEFT	○	○	○	○	○	○	○
	RIGHT	RIGHT	○	○	○	○	○	○	○

See Power Outside Mirror Folding System (SD878-1)

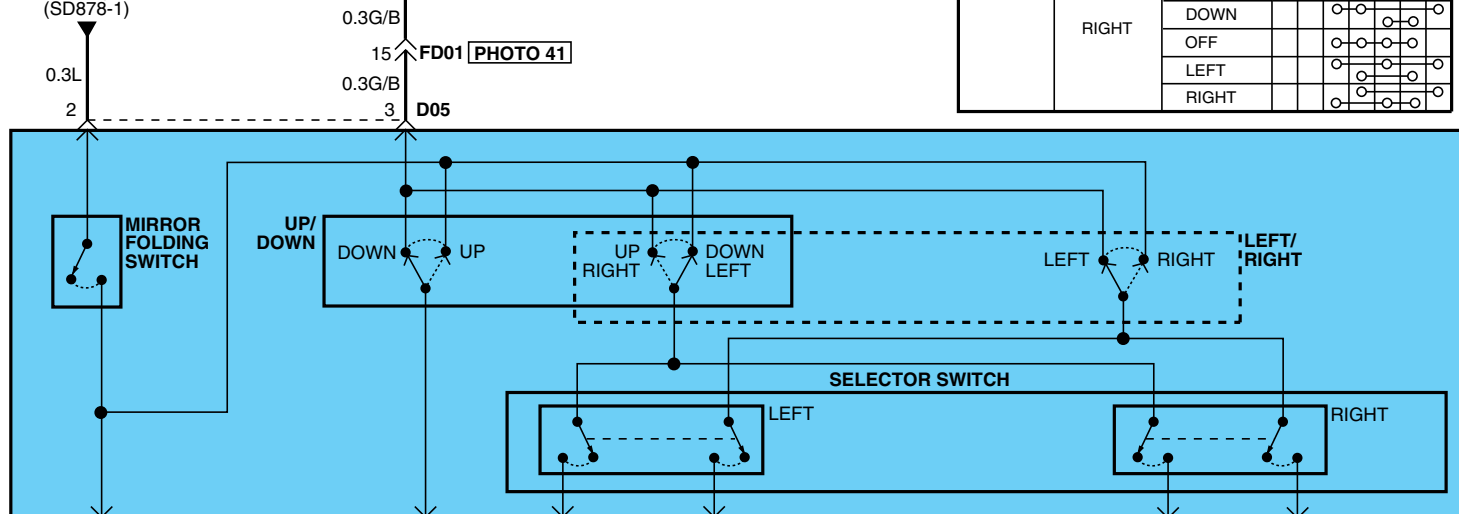

**POWER OUTSIDE MIRROR & MIRROR FOLDING SWITCH**  
(Refer to the table above for continuity between terminals)  
PHOTO 88

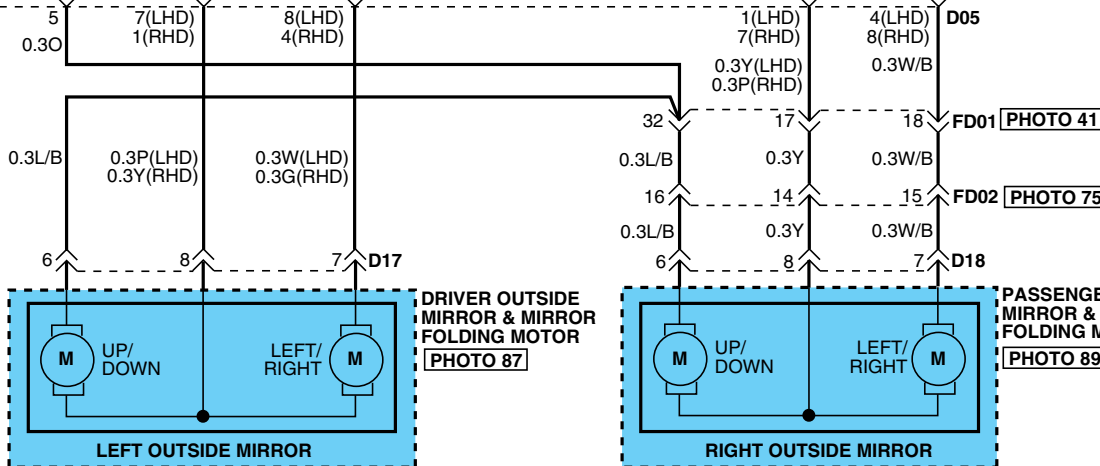
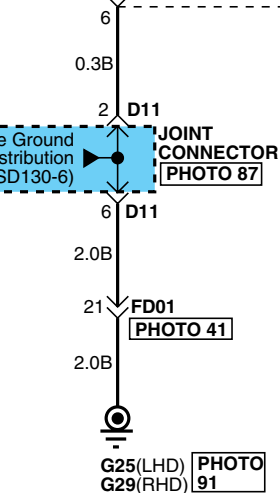

# POWER OUTSIDE MIRRORS

## POWER OUTSIDE MIRRORS (2)

SD876-2

D05

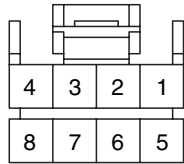

AMP\_040M1\_08F\_B

BLANK

D17

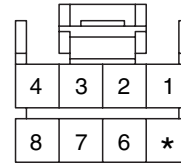

AMP\_040M1\_08F\_B

D18

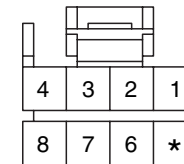

AMP\_040M1\_08F\_B

POWER OUTSIDE MIRROR FOLDING SYSTEM (1)

SD878-1

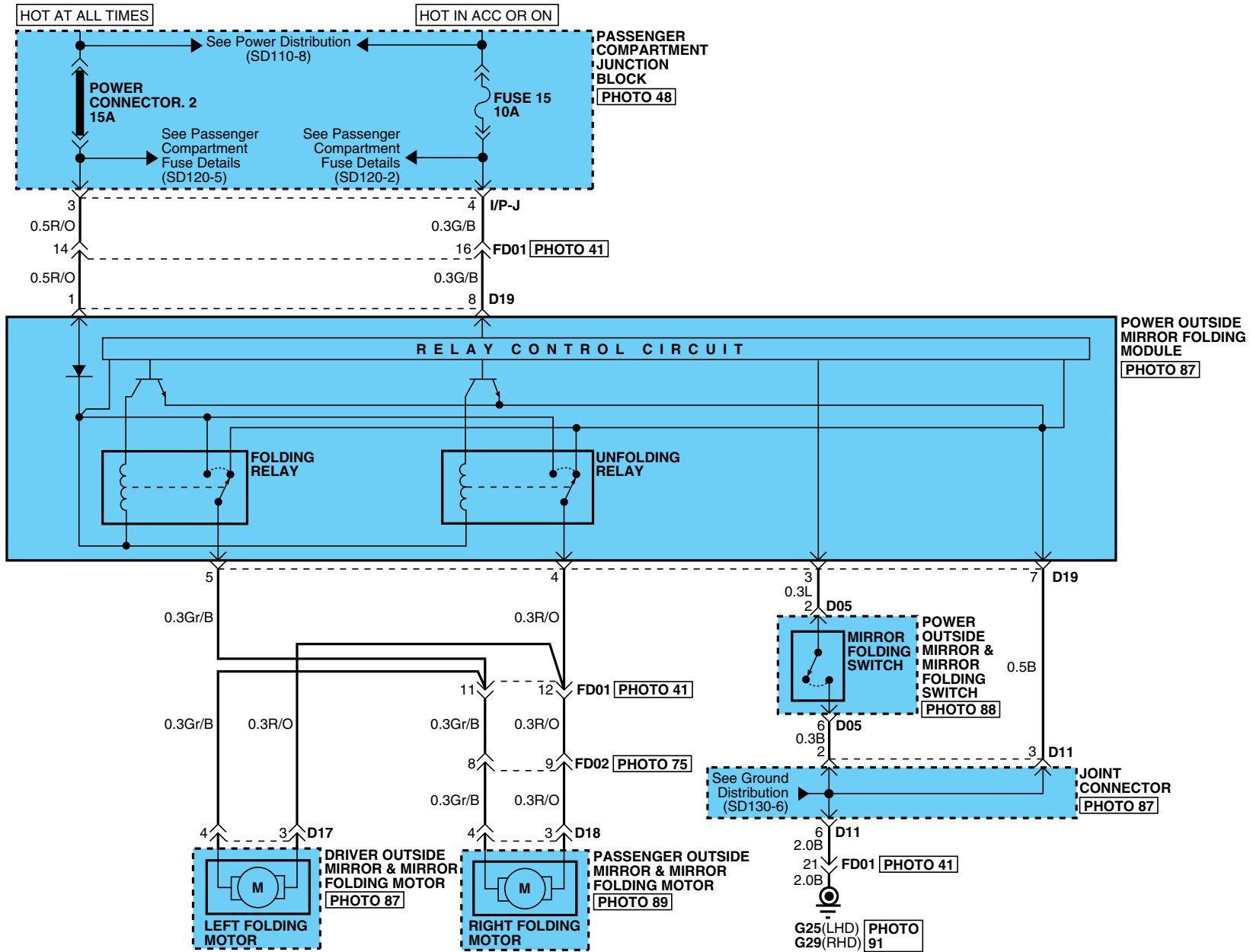

# POWER OUTSIDE MIRROR FOLDING SYSTEM

## POWER OUTSIDE MIRROR FOLDING SYSTEM (2)

SD878-2

D05

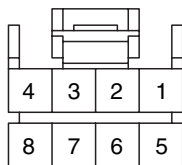

AMP\_040M1\_08F\_B

D17

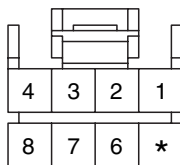

AMP\_040M1\_08F\_B

D18

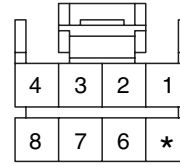

AMP\_040M1\_08F\_B

D19

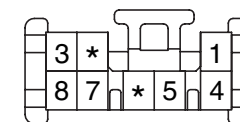

KET\_070II\_08F\_W\_PCB

GLASS & OUTSIDE MIRROR DEFOGGER (1)

SD879-1

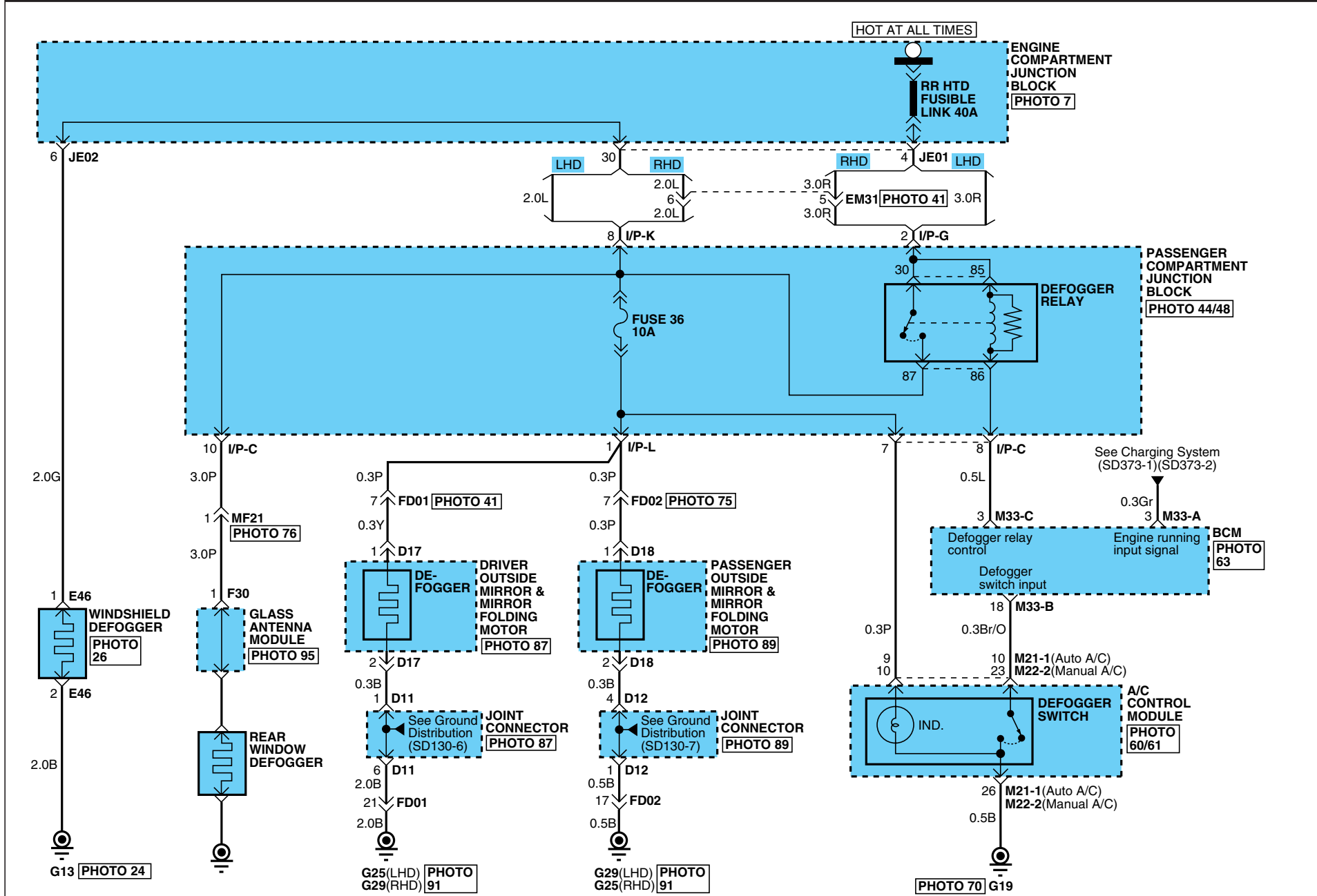



**GLASS & OUTSIDE MIRROR DEFOGGER**

**GLASS & OUTSIDE MIRROR DEFOGGER (2)**

**SD879-2**

**D17**

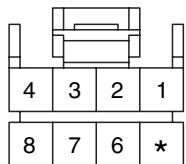

AMP\_040M1\_08F\_B

**D18**

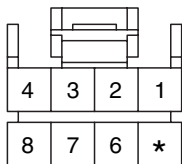

AMP\_040M1\_08F\_B

**E46**

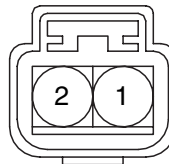

KUM\_NMWP\_02F\_B

**F30**



KET\_GLASS\_02F\_B\_ANT

**M21-1**

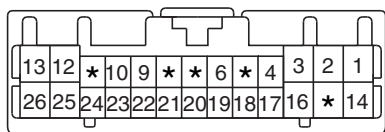

KET\_0407\_26F\_W

**M22-2**

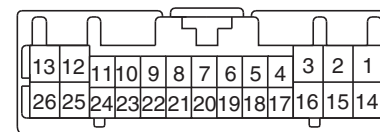

KET\_0407\_26F\_W

POWER SEAT (1)

SD880-1

DRIVER

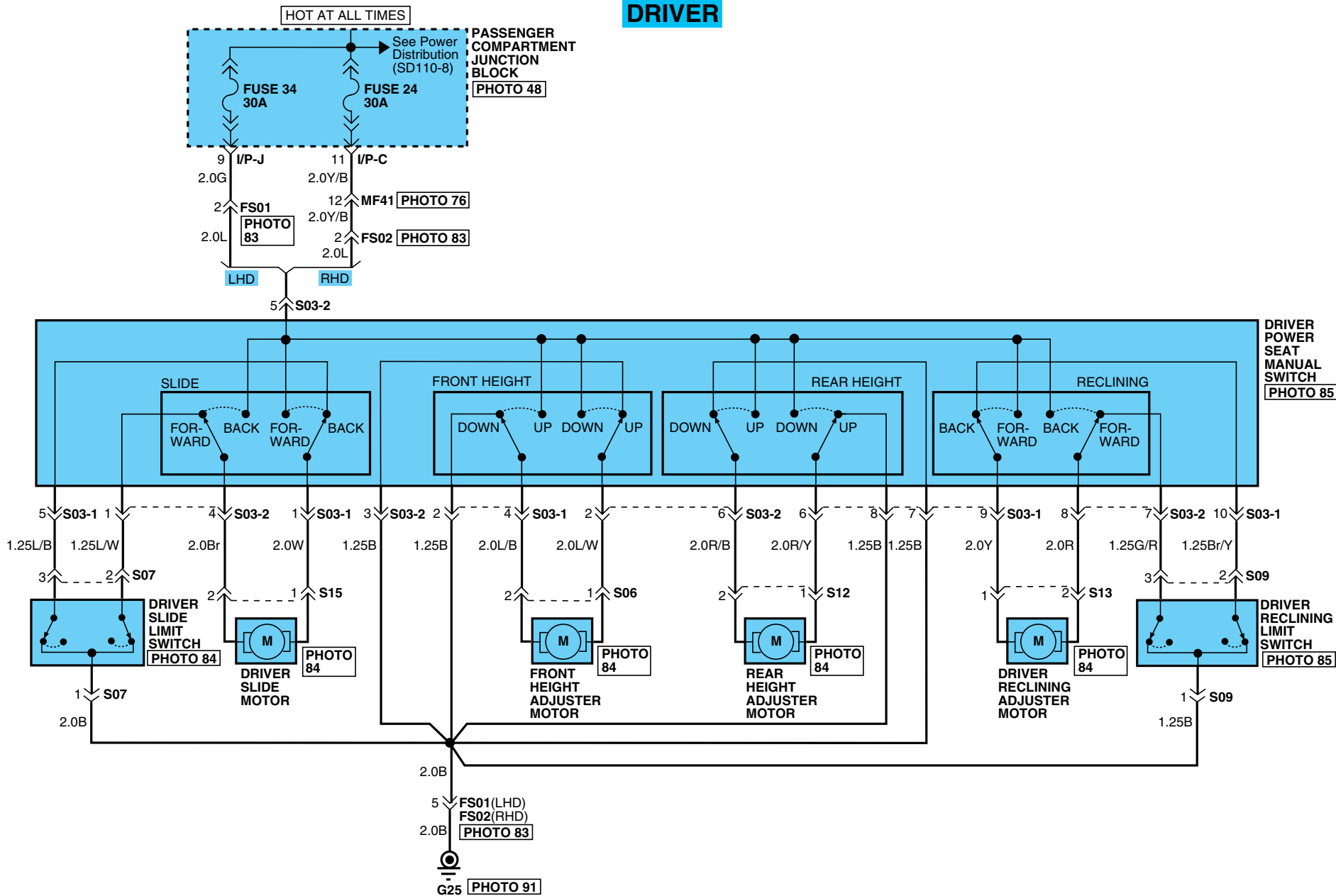

**PASSENGER**

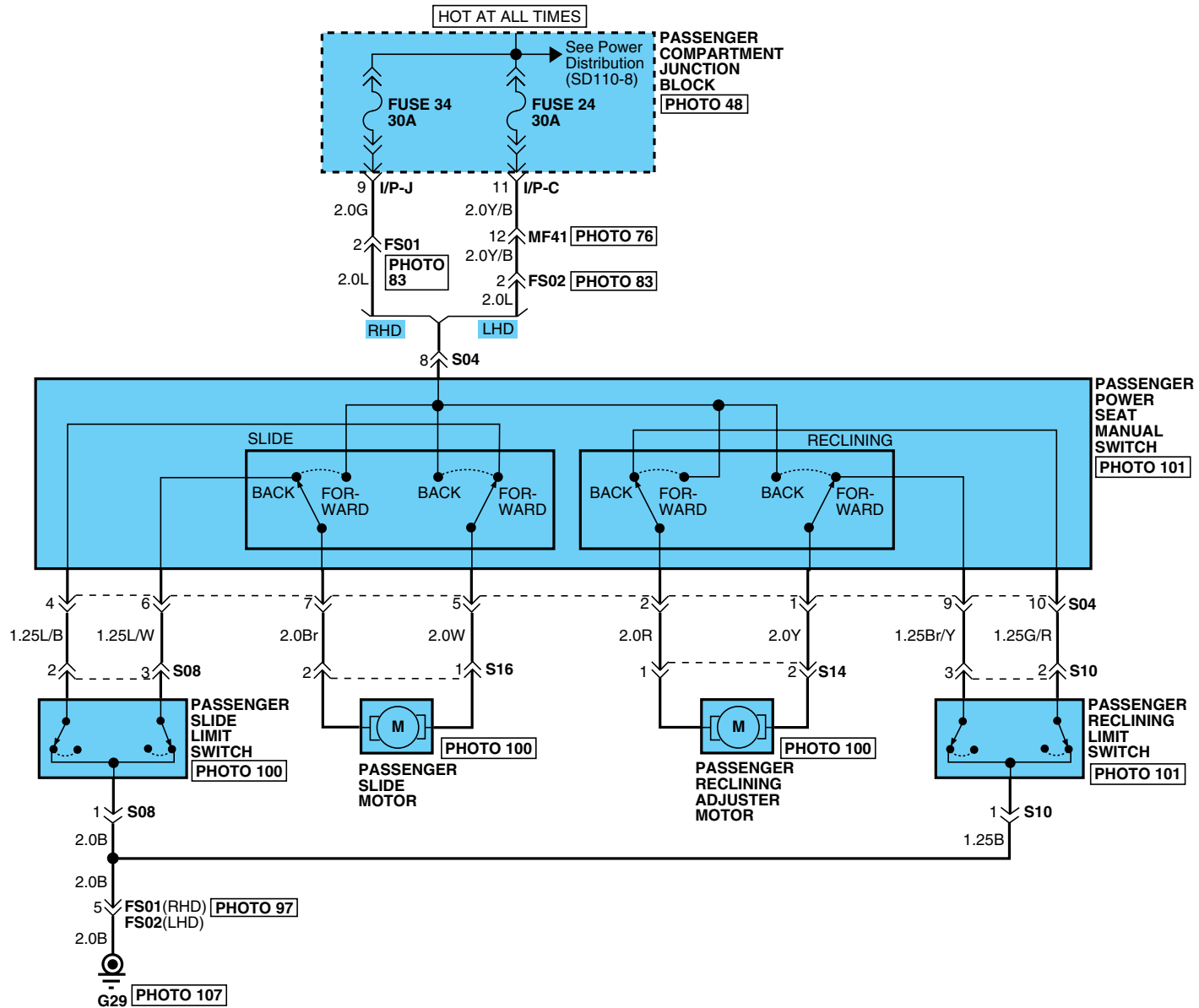

**POWER SEAT**

POWER SEAT (3)			SD880-3																															
<p><b>S03-1</b></p> <table border="1"> <tr> <td>4</td> <td>*</td> <td>▽</td> <td>2</td> <td>1</td> </tr> <tr> <td>10</td> <td>9</td> <td>8</td> <td>7</td> <td>6</td> <td>5</td> </tr> </table> <p>CR10F003</p>	4	*	▽	2	1	10	9	8	7	6	5	<p><b>S03-2</b></p> <table border="1"> <tr> <td>3</td> <td>2</td> <td>▽</td> <td>1</td> </tr> <tr> <td>8</td> <td>7</td> <td>6</td> <td>5</td> <td>4</td> </tr> </table> <p>CR08F004</p>	3	2	▽	1	8	7	6	5	4	<p><b>BLANK</b></p>	<p><b>S04</b></p> <table border="1"> <tr> <td>4</td> <td>*</td> <td>▽</td> <td>2</td> <td>1</td> </tr> <tr> <td>10</td> <td>9</td> <td>8</td> <td>7</td> <td>6</td> <td>5</td> </tr> </table> <p>CR10F003</p>	4	*	▽	2	1	10	9	8	7	6	5
4	*	▽	2	1																														
10	9	8	7	6	5																													
3	2	▽	1																															
8	7	6	5	4																														
4	*	▽	2	1																														
10	9	8	7	6	5																													
<p><b>S06</b></p> <p>CR02F012</p>	<p><b>S07</b></p> <p>CR03F005</p>	<p><b>S08</b></p> <p>CR03F005</p>	<p><b>S09</b></p> <p>CR03F005</p>																															
<p><b>S10</b></p> <p>CR03F005</p>	<p><b>BLANK</b></p>	<p><b>S12</b></p> <p>CR02M053</p>	<p><b>S13</b></p> <p>CR02M053</p>																															
<p><b>S14</b></p> <p>CR02M053</p>	<p><b>S15</b></p> <p>CR02F012</p>	<p><b>S16</b></p> <p>CR02F012</p>	<p><b>BLANK</b></p>																															

**POWER SEAT**

**POWER SEAT (4)**

**SD880-4**

**MEMO**

SEAT WARMER (1)

SD889-1

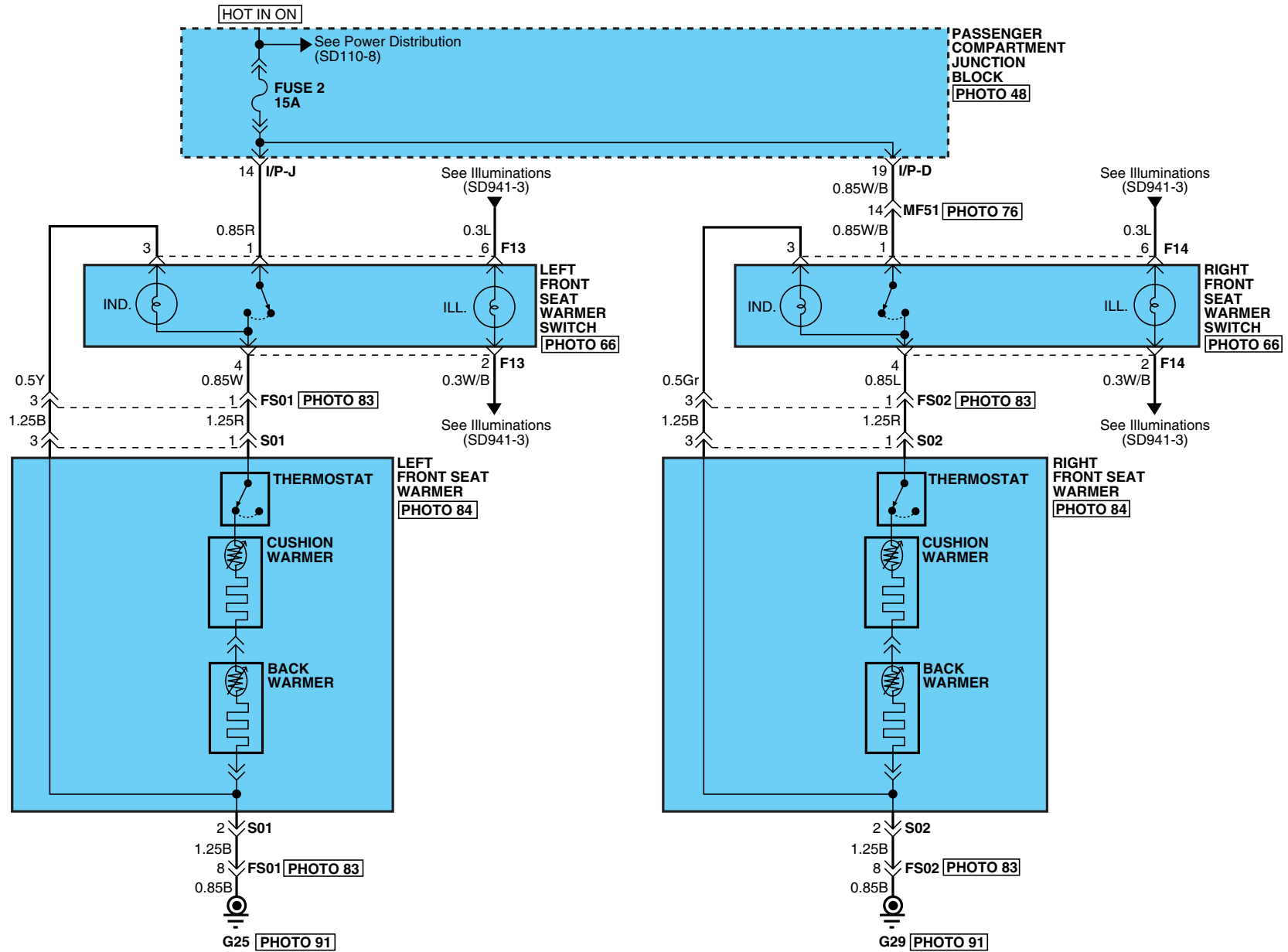

# SEAT WARMER

## SEAT WARMER (2)

SD889-2

F13

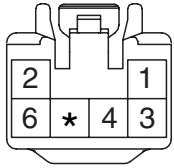

KET\_090III\_06F\_Y

F14

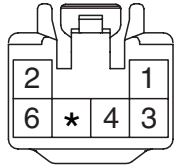

KET\_090III\_06F\_L

S01

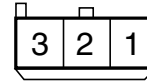

CR03F026

S02

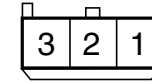

CR03F026

HEAD LAMPS (1)

SD921-1

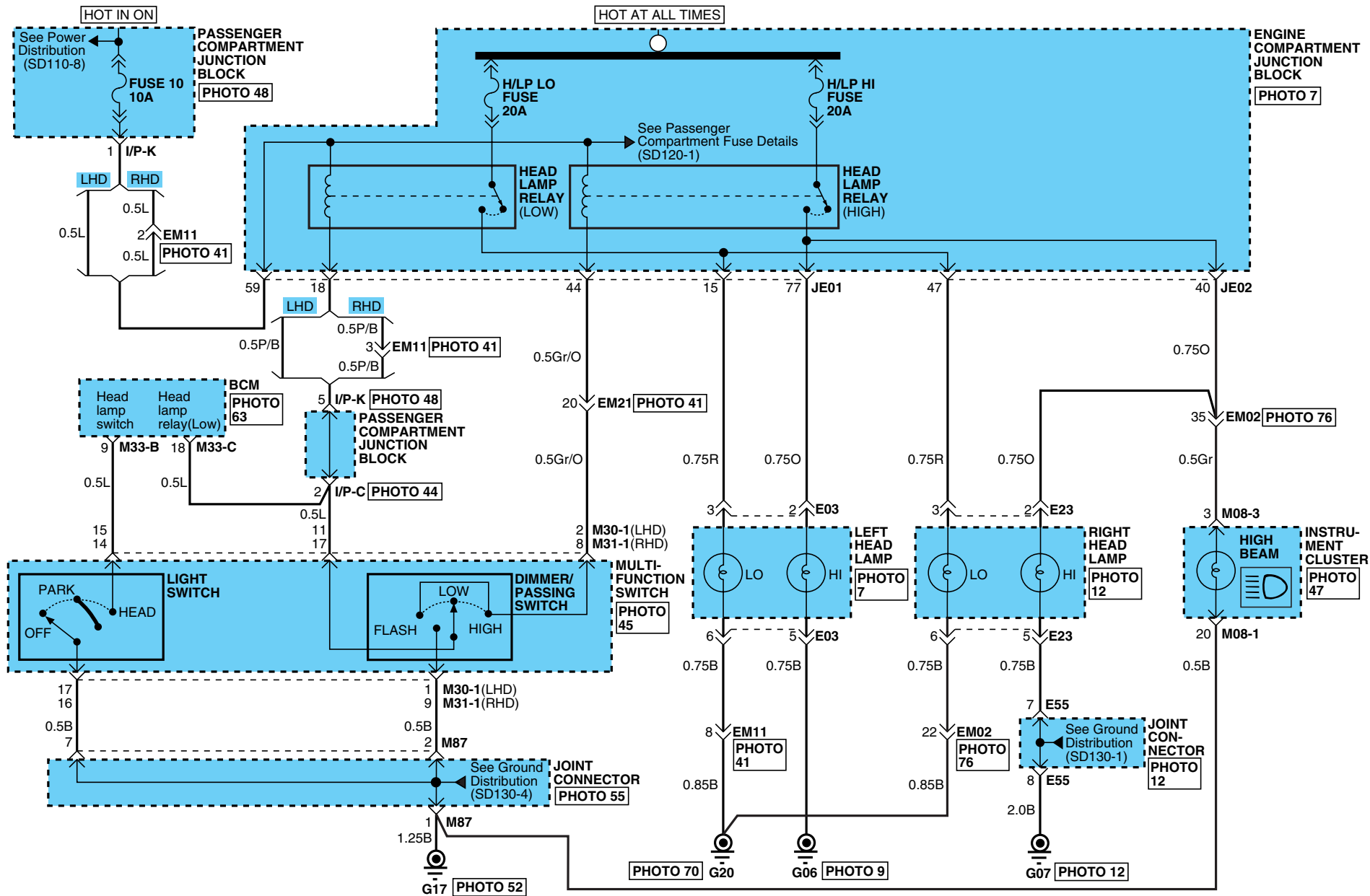



# HEAD LAMPS

## HEAD LAMPS (2)

SD921-2

**E03**



KUM\_NMWP\_06F\_B

**E23**

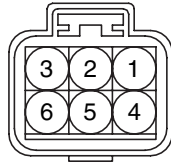

KUM\_NMWP\_06F\_B

**M08-1**

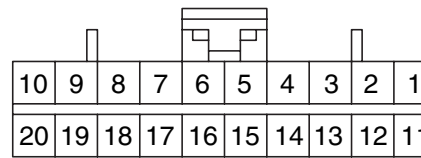

AMP\_040M2\_20F\_B

**M08-3**

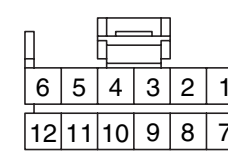

AMP\_040M1\_12F\_B

**M30-1**

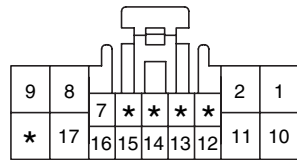

KET\_0509\_18F\_W

**M31-1**

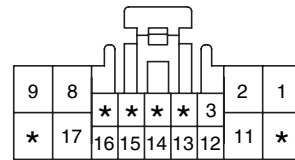

KET\_0509\_18F\_W

**M33-B**

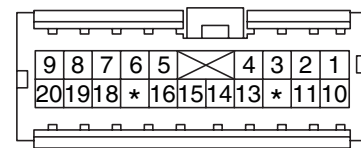

AMP\_040III\_20F\_W

**M33-C**

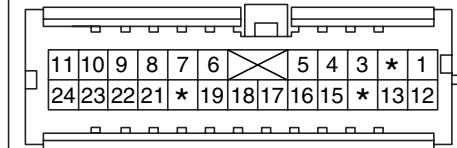

AMP\_040III\_24F\_GR

HEAD LAMP LEVELING DEVICE (1)

SD922-1

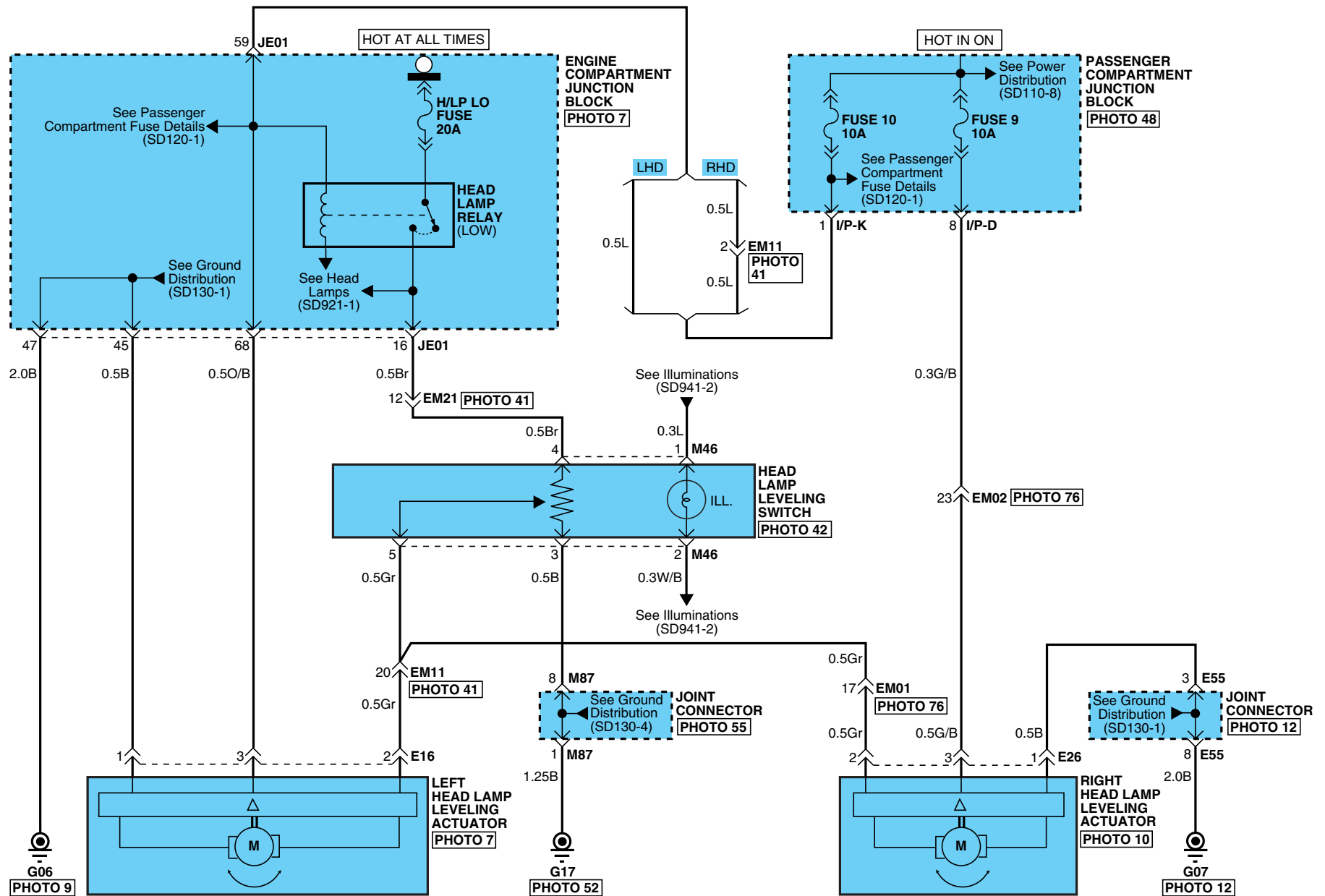

# HEAD LAMP LEVELING DEVICE

## HEAD LAMP LEVELING DEVICE (2)

SD922-2

**E16**

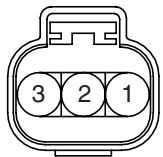

AMP\_025WP\_03F\_B

**E26**

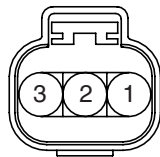

AMP\_025WP\_03F\_B

**M46**

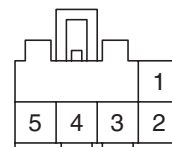

KUM\_CDR\_05F\_W

**BLANK**

HEAD LAMP WASHER (1)

SD923-1

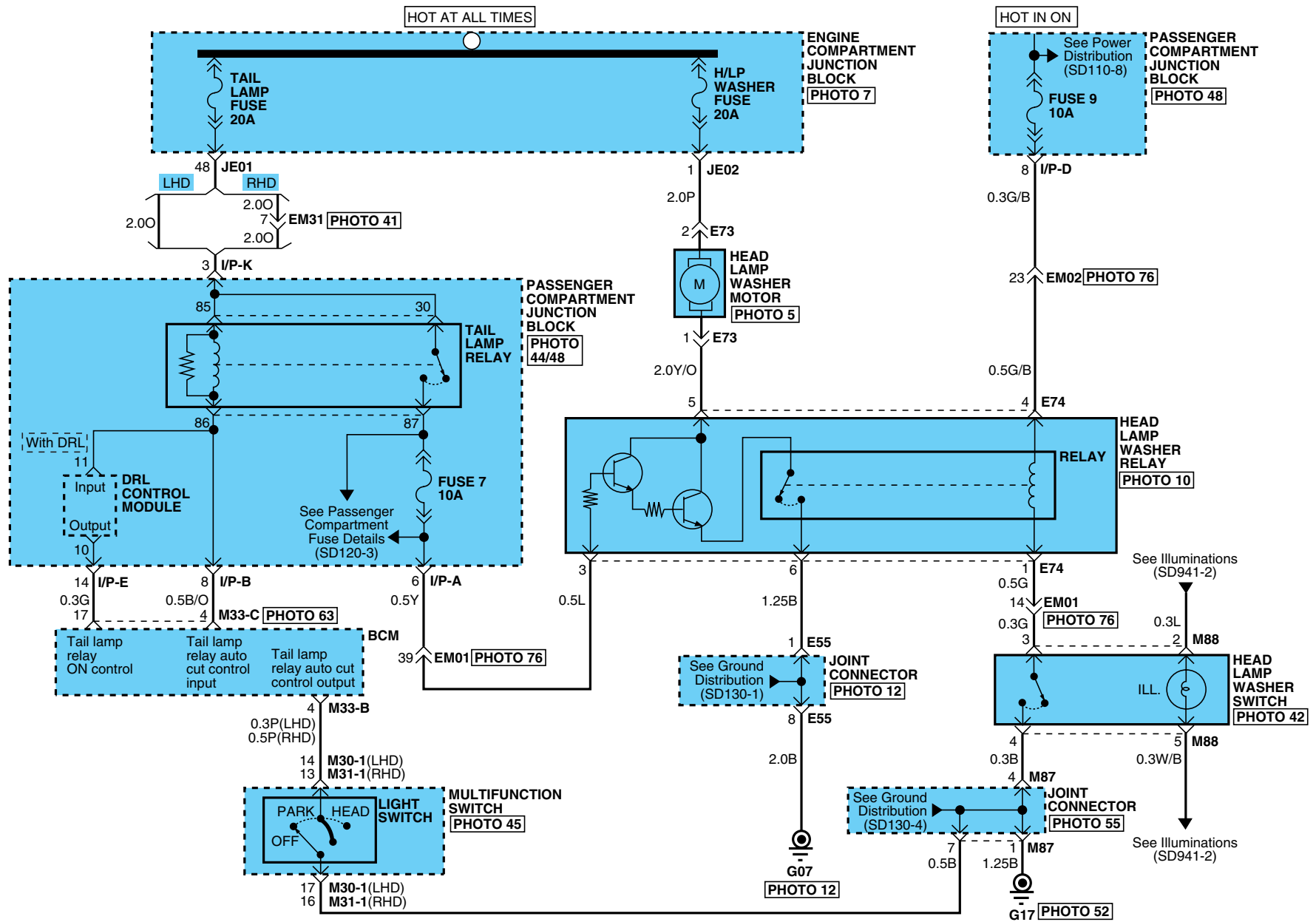

# HEAD LAMP WASHER

## HEAD LAMP WASHER (2)

SD923-2

**E73**

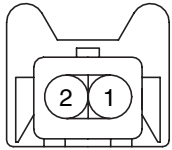

AMP\_JPT\_02F\_B

**E74**

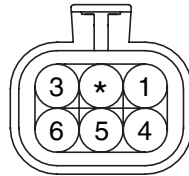

KET\_58W\_06F\_W

**M30-1**

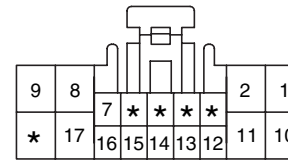

KET\_0509\_18F\_W

**M31-1**

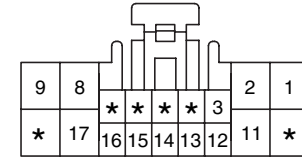

KET\_0509\_18F\_W

**M33-B**

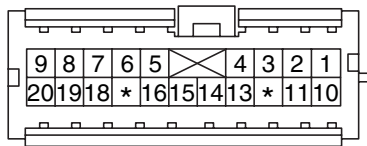

AMP\_040III\_20F\_W

**M33-C**

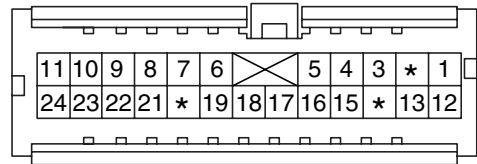

AMP\_040III\_24F\_GR

**M88**

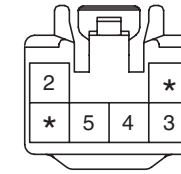

KET\_090III\_06F\_GR

FRONT FOG & REAR FOG LAMPS (1)

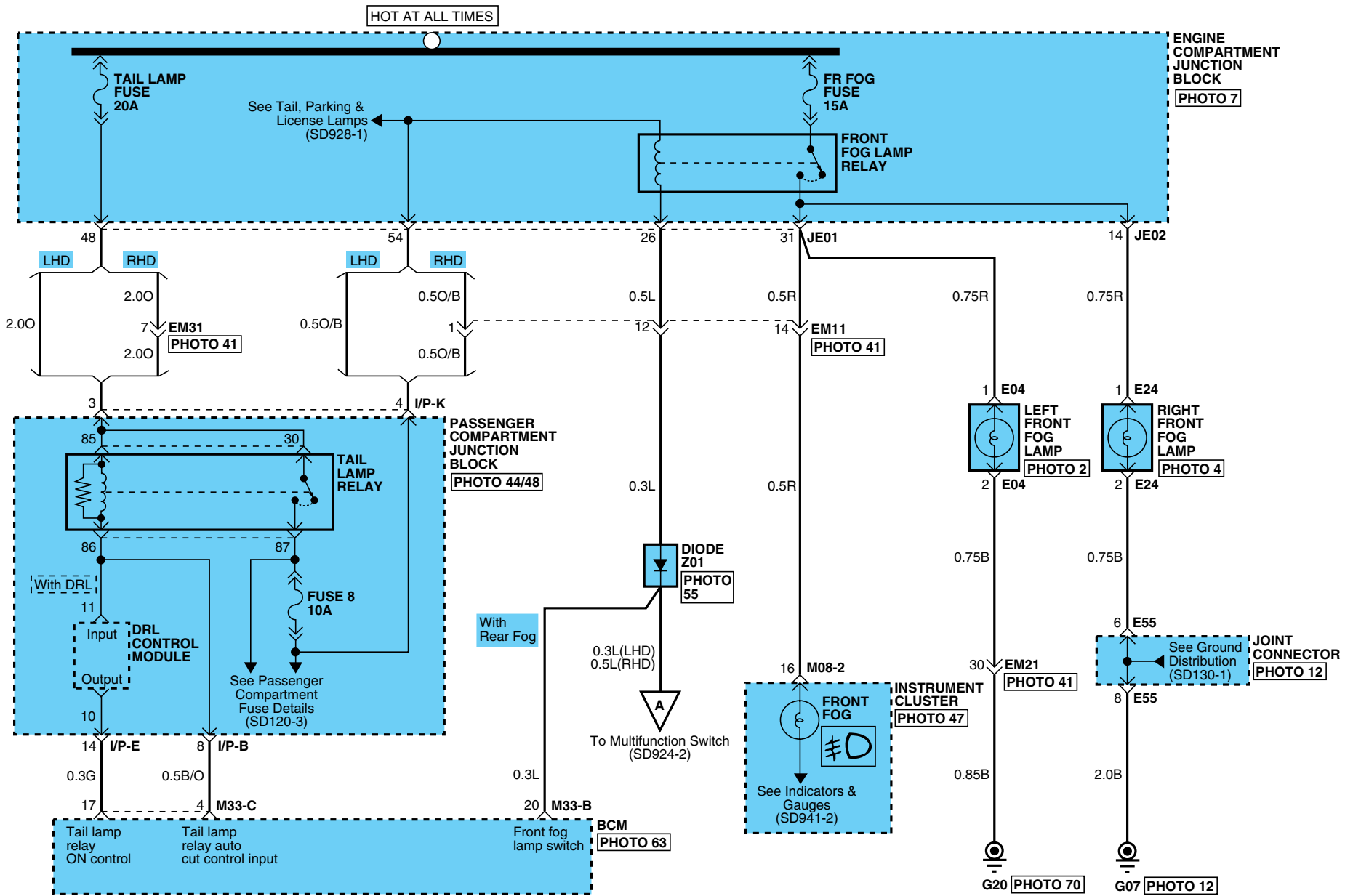

# FRONT FOG & REAR FOG LAMPS

## FRONT FOG & REAR FOG LAMPS (2)

SD924-2

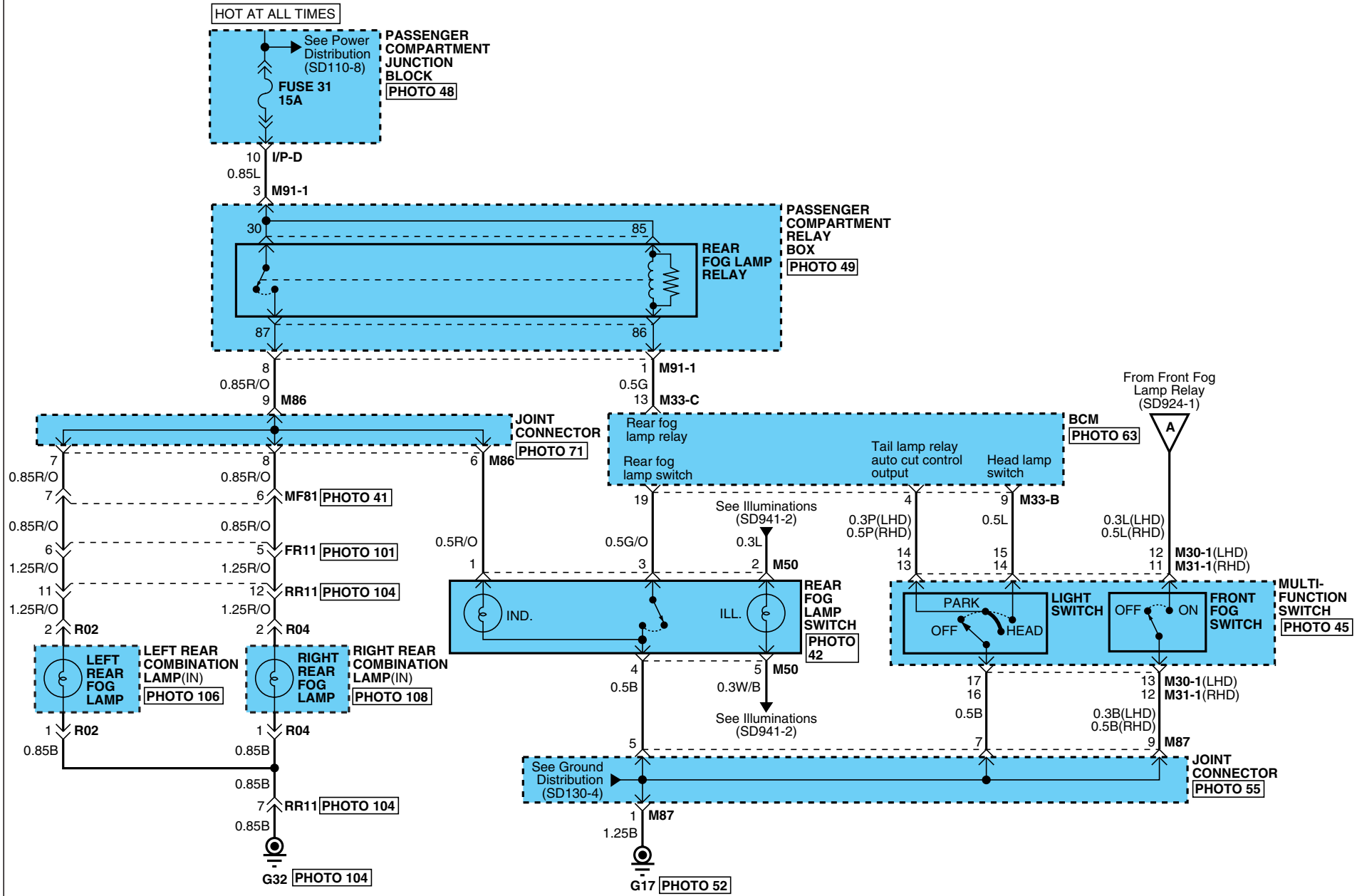

# FRONT FOG & REAR FOG LAMPS

## FRONT FOG & REAR FOG LAMPS (3)

SD924-3

**E04**



KET\_110WP\_02F\_B\_FOG

**E24**



KET\_110WP\_02F\_B\_FOG

**M08-2**

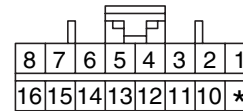

AMP\_040M2\_16F\_B

**M30-1**

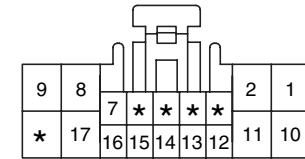

KET\_0509\_18F\_W

**M31-1**

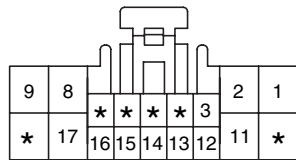

KET\_0509\_18F\_W

**M33-B**

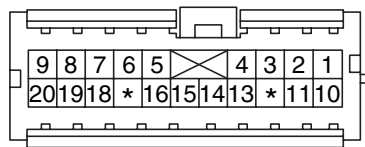

AMP\_040III\_20F\_W

**M33-C**

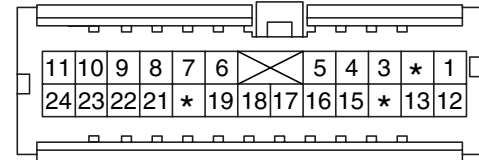

AMP\_040III\_24F\_GR

**M50**

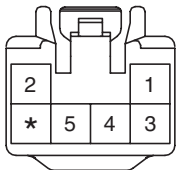

KET\_090III\_06F\_BR

**M91-1**

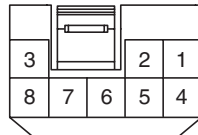

AMP\_090III\_08F\_W

**R02**

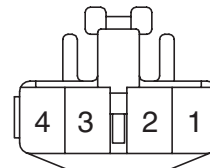

KET\_090III\_04F\_W

**R04**

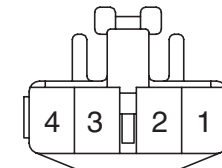

KET\_090III\_04F\_W



**FRONT FOG & REAR FOG LAMPS**

**FRONT FOG & REAR FOG LAMPS (4)**

**SD924-4**

**MEMO**

TURN & HAZARD LAMPS (1)

SD925-1

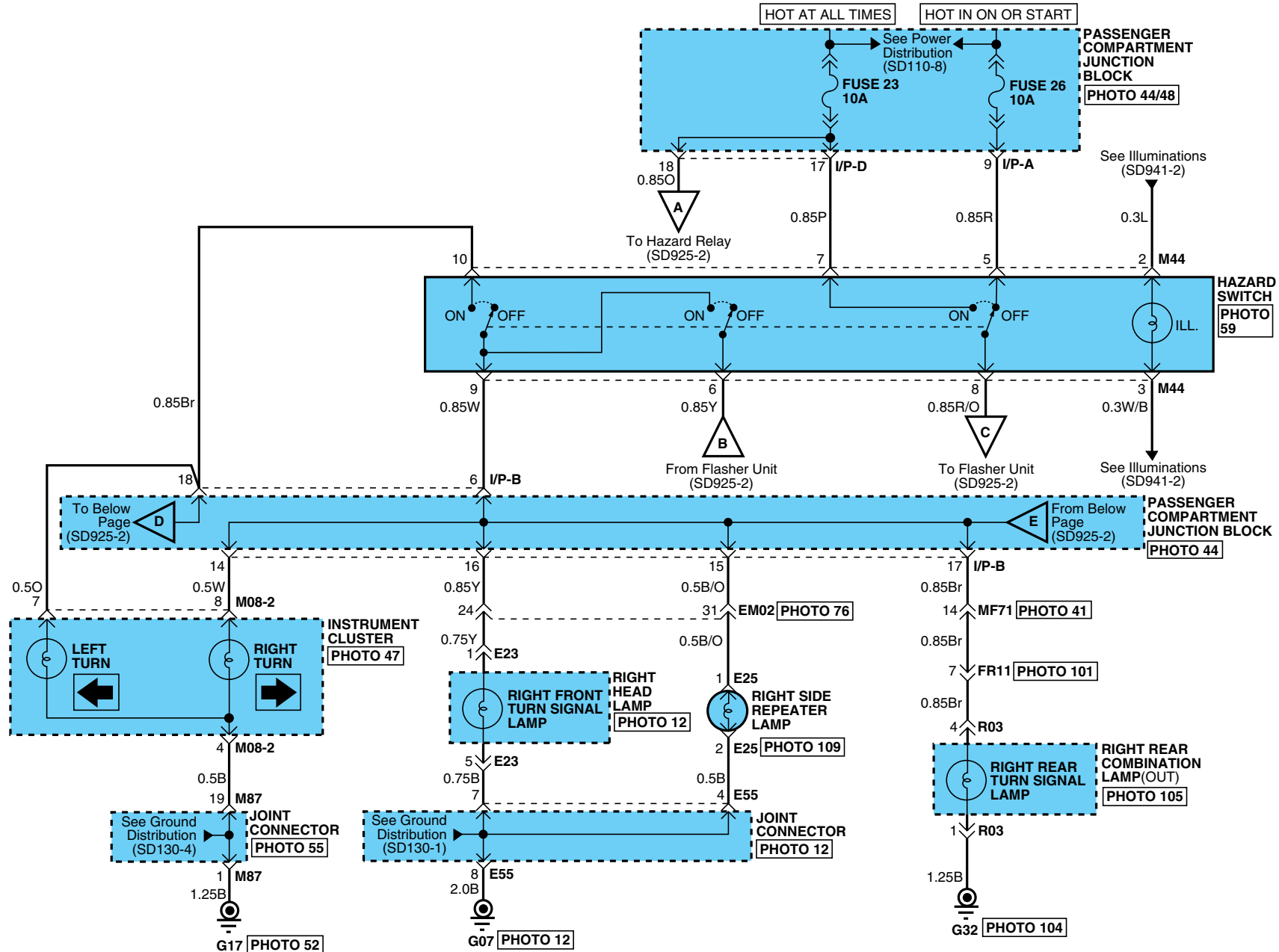

# TURN & HAZARD LAMPS

## TURN & HAZARD LAMPS (2)

SD925-2

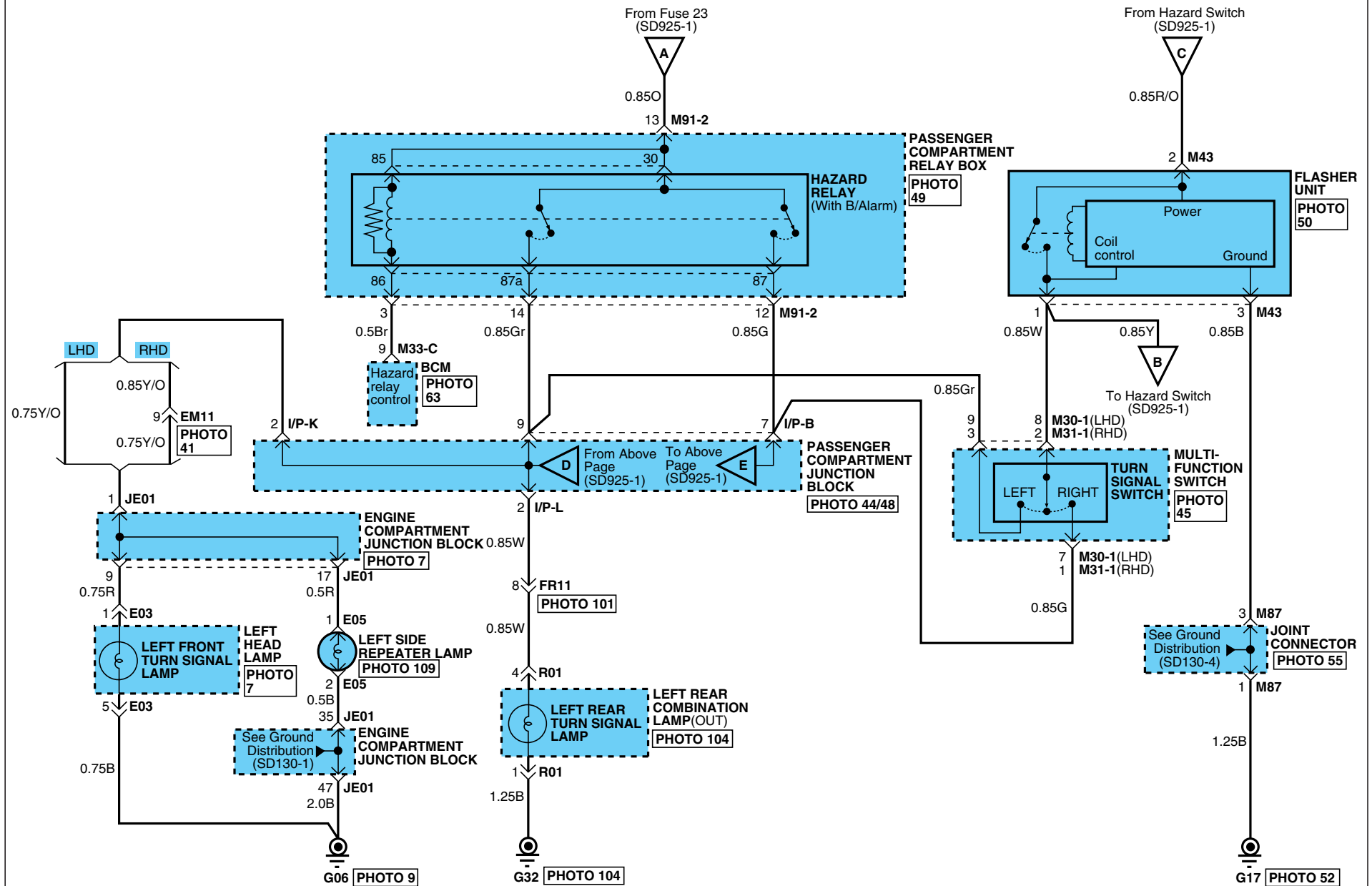

# TURN & HAZARD LAMPS

## TURN & HAZARD LAMPS (3)

SD925-3

**E03**



KUM\_NMWP\_06F\_B

**E05**

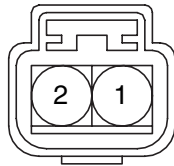

KUM\_NMWP\_02F\_B

**E23**

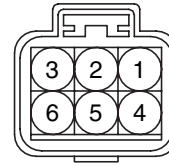

KUM\_NMWP\_06F\_B

**E25**

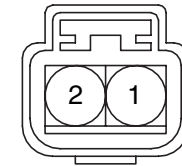

KUM\_NMWP\_02F\_B

**M08-2**

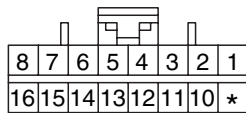

AMP\_040M2\_16F\_B

**M30-1**

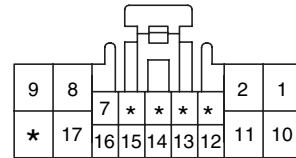

KET\_0509\_18F\_W

**M31-1**

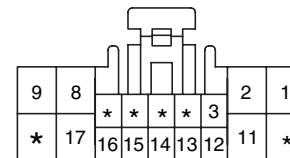

KET\_0509\_18F\_W

**M43**

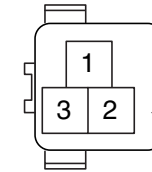

AMP\_187\_03F\_B\_RLY

**M44**

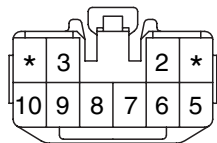

KET\_090III\_10F\_W

**M91-2**

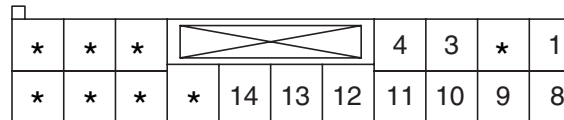

AMP\_0925\_18F\_W

**R01**

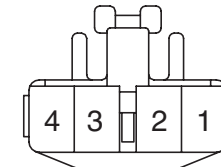

KET\_090III\_04F\_W

**R03**

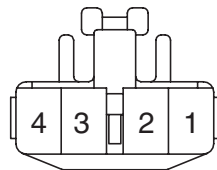

KET\_090III\_04F\_W

**BLANK**

**BLANK**

**BLANK**

**TURN & HAZARD LAMPS**

**TURN & HAZARD LAMPS (4)**

**SD925-4**

**MEMO**

BACK-UP LAMPS & BACK WARNING SYSTEM (1)

SD926-1

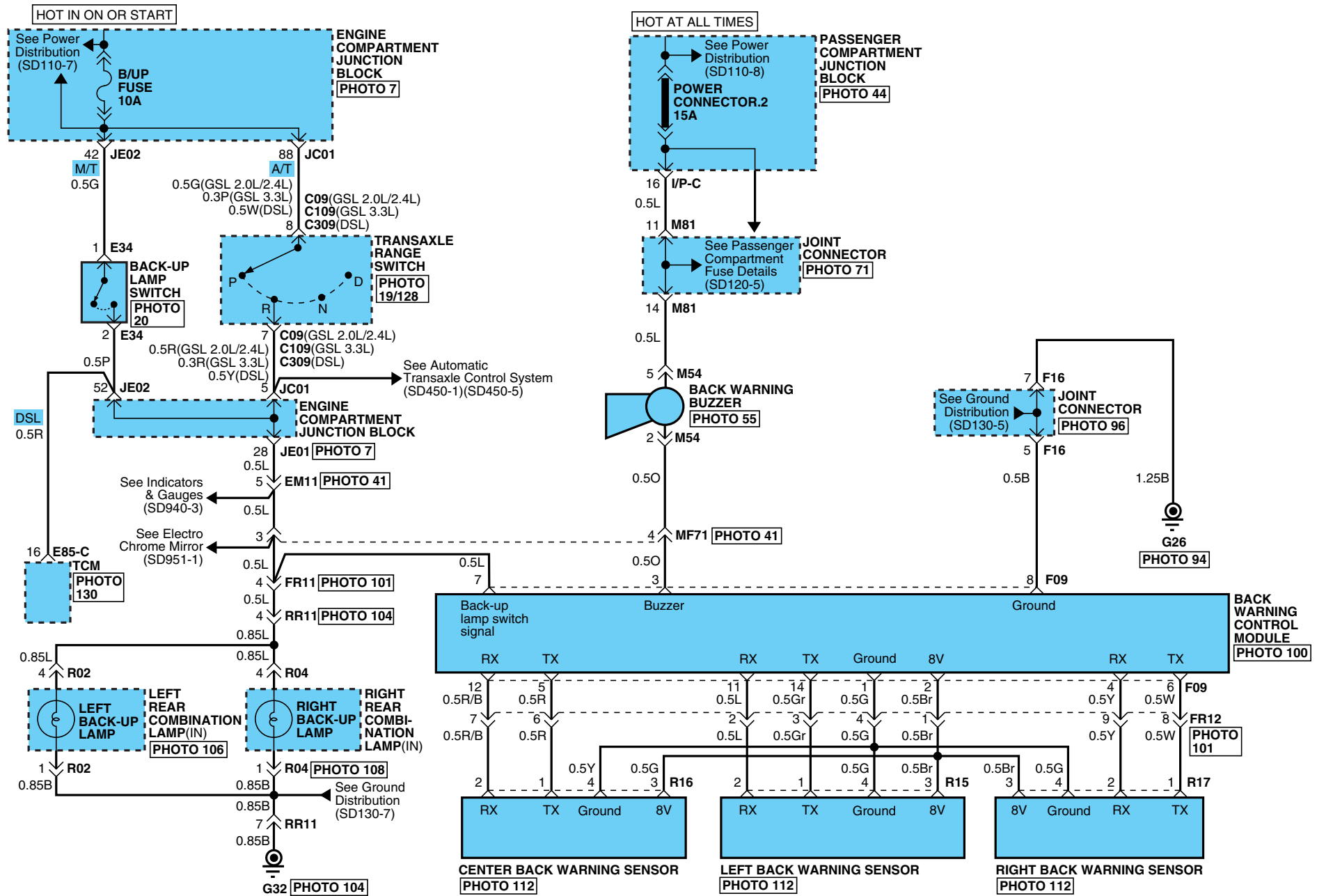

**BACK-UP LAMPS & BACK WARNING SYSTEM**

**BACK-UP LAMPS & BACK WARNING SYSTEM (2)**

**SD926-2**

**C09/C109/C309**



KET\_SSD\_10F\_B\_A

**E34**

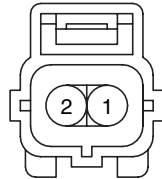

AMP\_EJWP\_02F\_B

**F09**

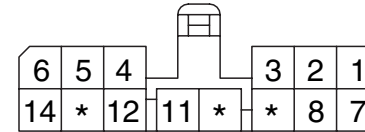

AMP\_070\_14F\_W

**M54**

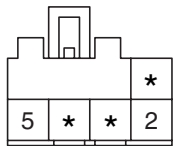

KUM\_CDR\_05F\_W

**BLANK**

**R02**

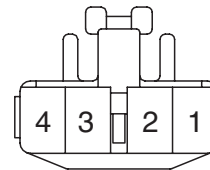

KET\_090III\_04F\_W

**R04**

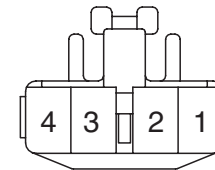

KET\_090III\_04F\_W

**BLANK**

**R15**

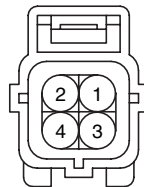

AMP\_EJWP\_04F\_B

**R16**

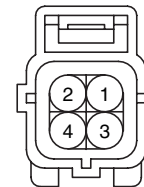

AMP\_EJWP\_04F\_B

**R17**

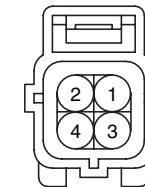

AMP\_EJWP\_04F\_B

STOP LAMPS (1)

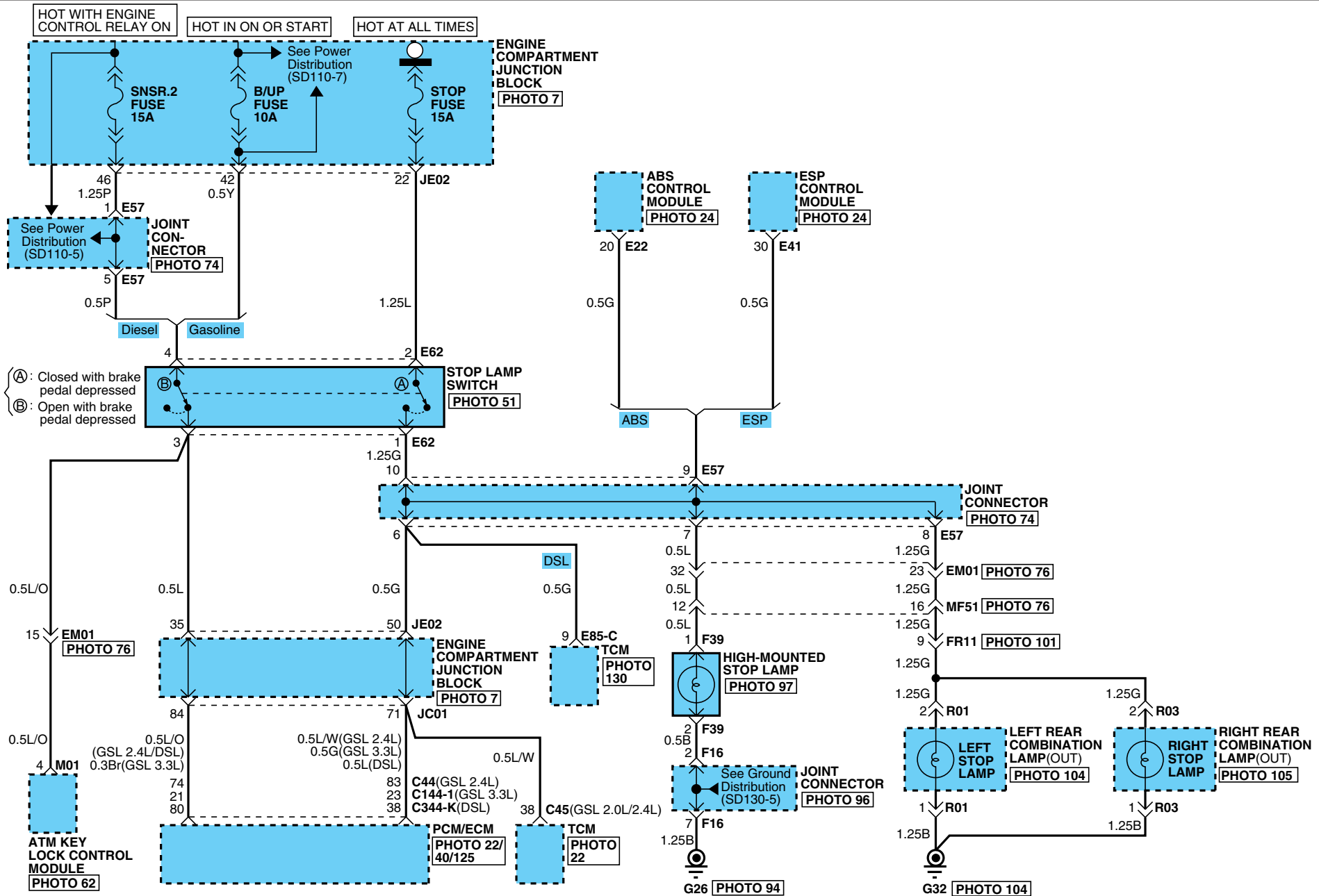



# STOP LAMPS

## STOP LAMPS (2)

SD927-2

**E62**

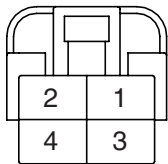

KET\_250DL\_04F\_W

**F39**

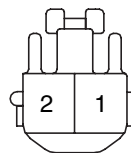

KET\_090III\_02F\_W\_L

**R01**

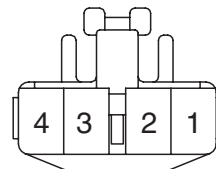

KET\_090III\_04F\_W

**R03**

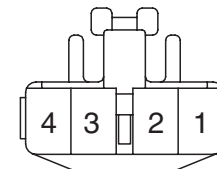

KET\_090III\_04F\_W

TAIL, PARKING & LICENSE LAMPS (1)

SD928-1

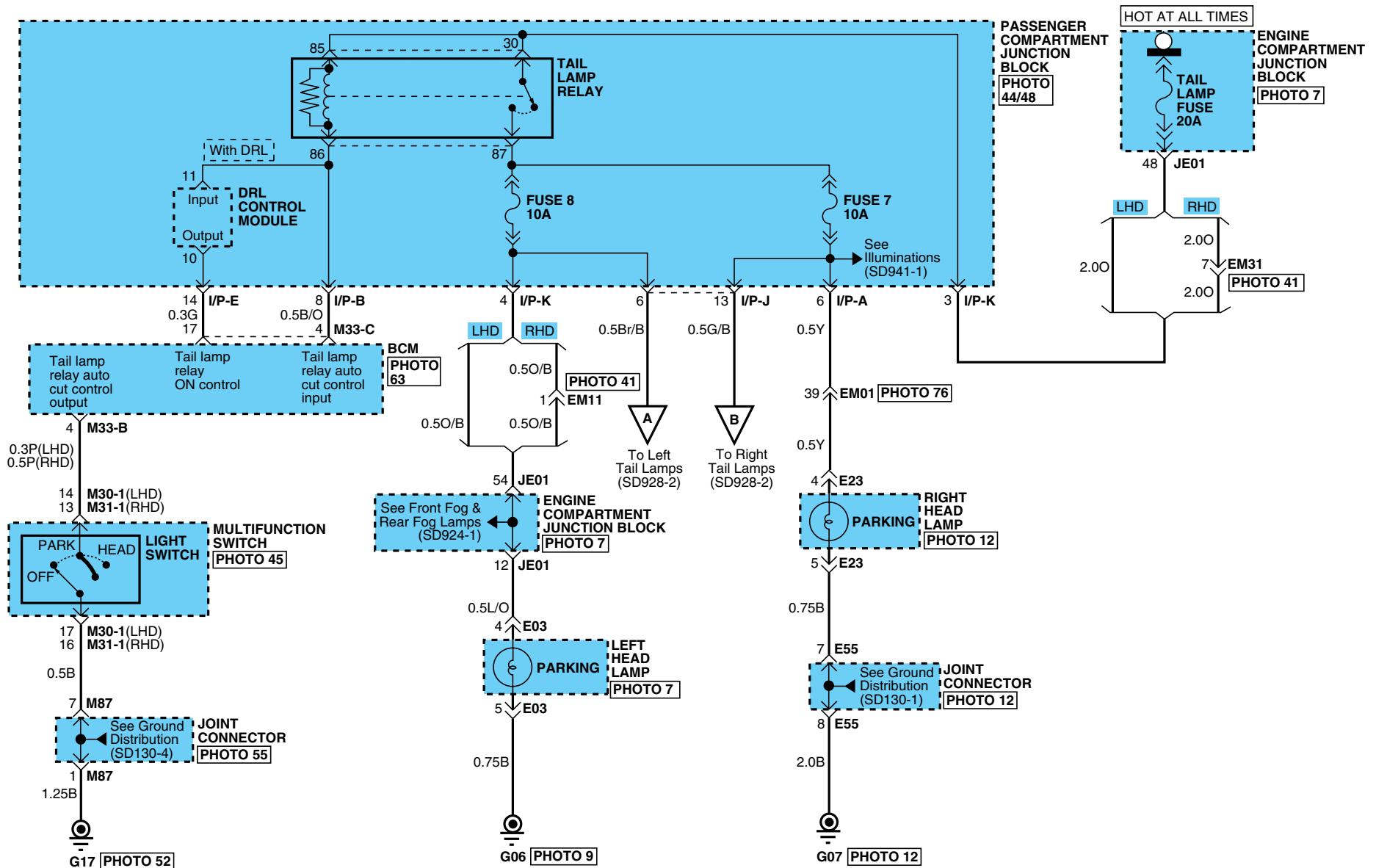

# TAIL, PARKING & LICENSE LAMPS

## TAIL, PARKING & LICENSE LAMPS (2)

SD928-2

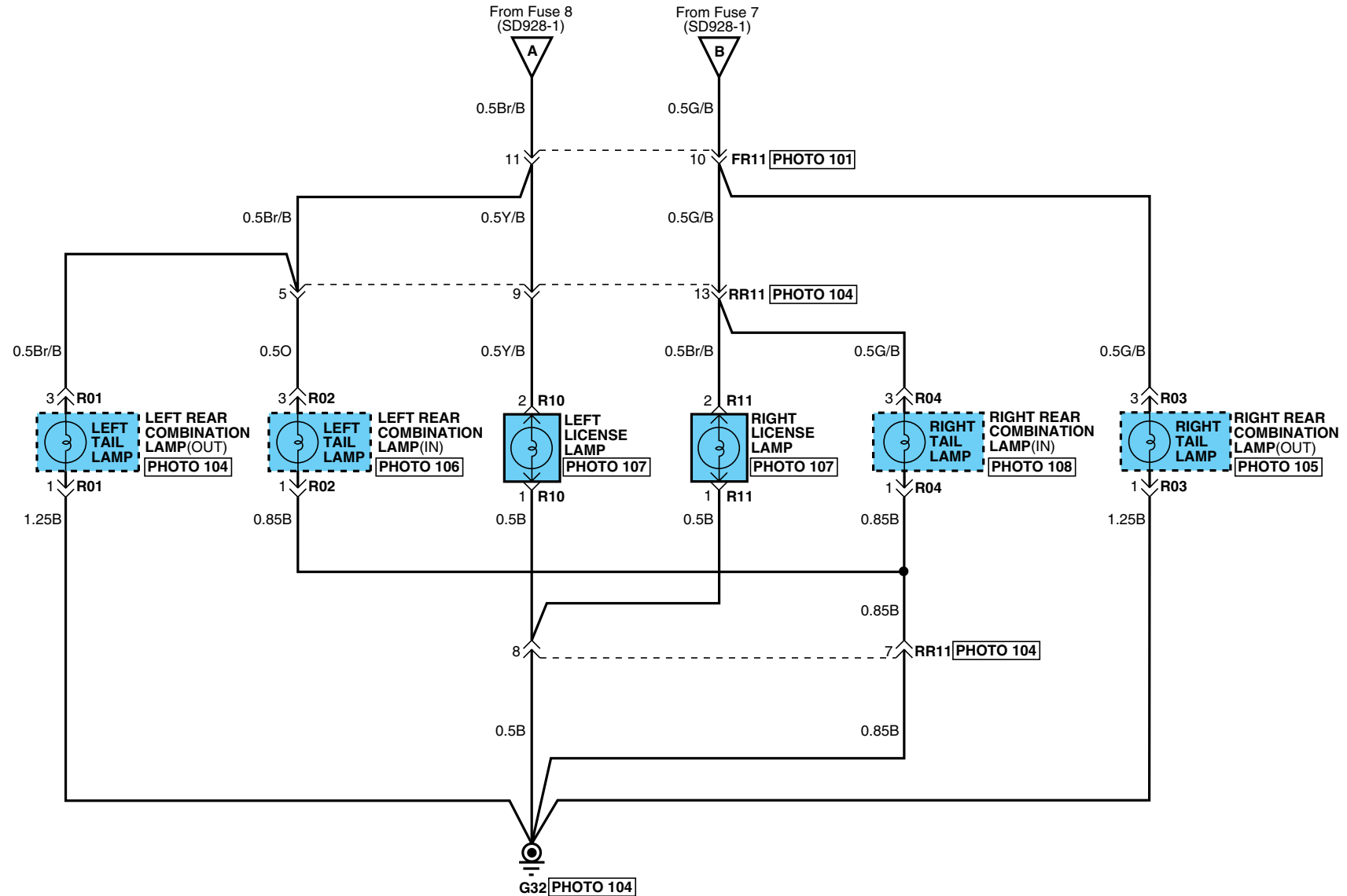

# TAIL, PARKING & LICENSE LAMPS

## TAIL, PARKING & LICENSE LAMPS (3)

SD928-3

**E03**



KUM\_NMWP\_06F\_B

**E23**

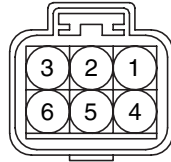

KUM\_NMWP\_06F\_B

**M30-1**

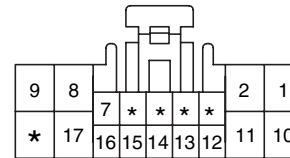

KET\_0509\_18F\_W

**M31-1**

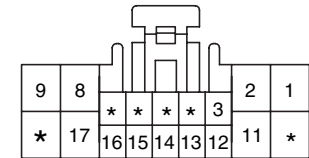

KET\_0509\_18F\_W

**M33-B**

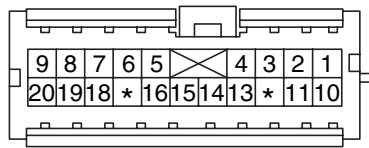

AMP\_040III\_20F\_W

**M33-C**

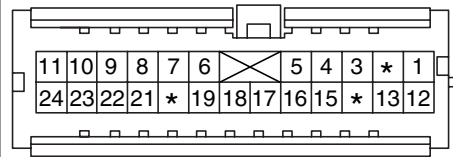

AMP\_040III\_24F\_GR

**R01**

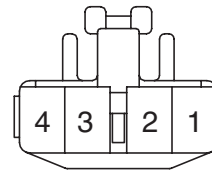

KET\_090III\_04F\_W

**R02**

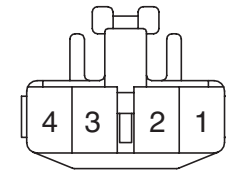

KET\_090III\_04F\_W

**R03**

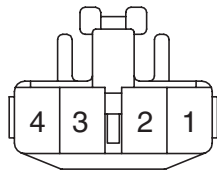

KET\_090III\_04F\_W

**R04**

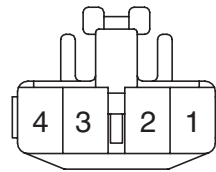

KET\_090III\_04F\_W

**R10**

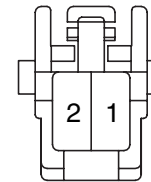

KET\_050\_02F\_W

**R11**

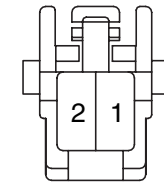

KET\_050\_02F\_W

**TAIL, PARKING & LICENSE LAMPS**

**TAIL, PARKING & LICENSE LAMPS (4)**

**SD928-4**

**MEMO**

COURTESY & TRUNK ROOM LAMPS (1)

SD929-1

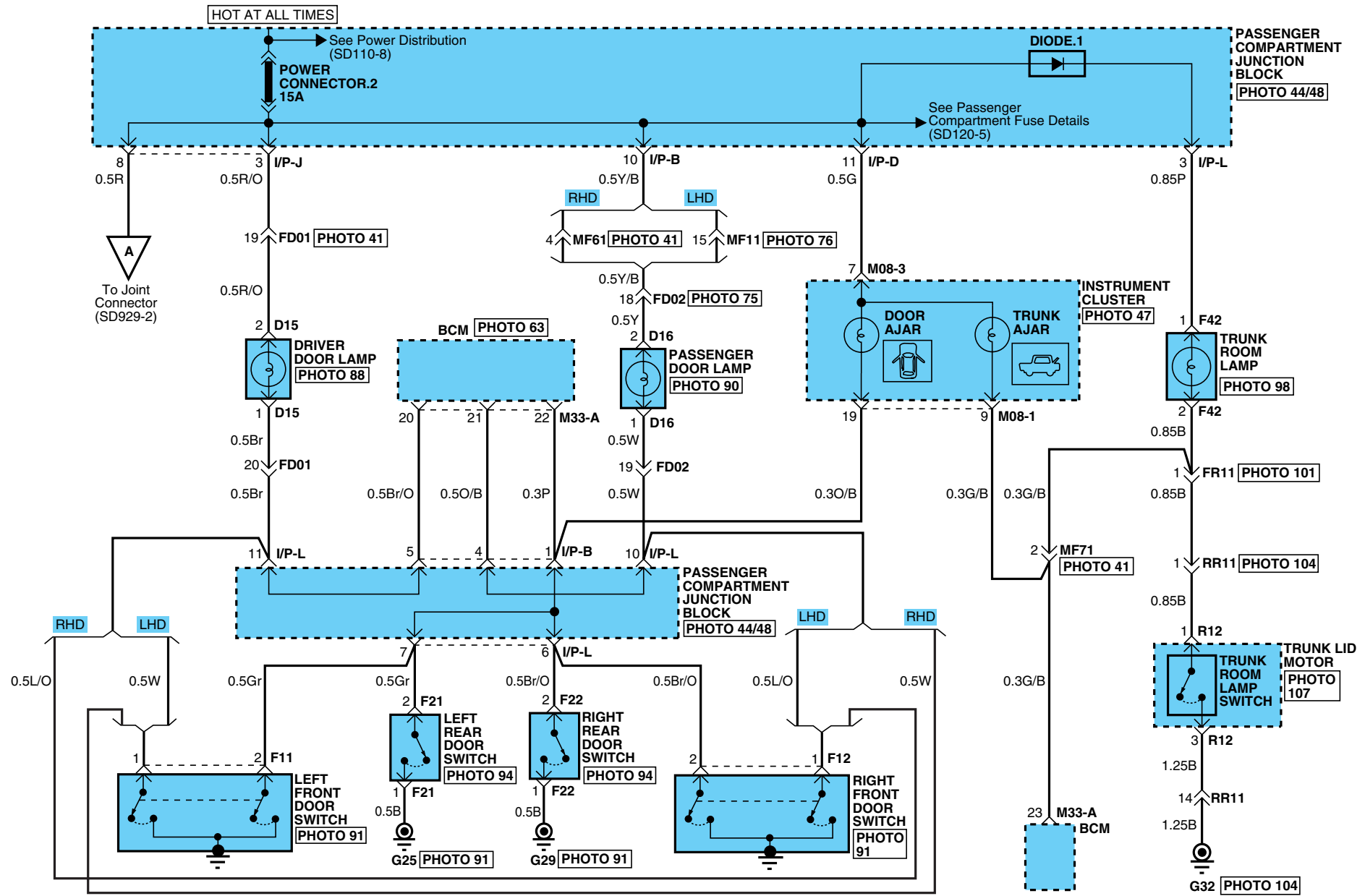

# COURTESY & TRUNK ROOM LAMPS

## COURTESY & TRUNK ROOM LAMPS (2)

SD929-2

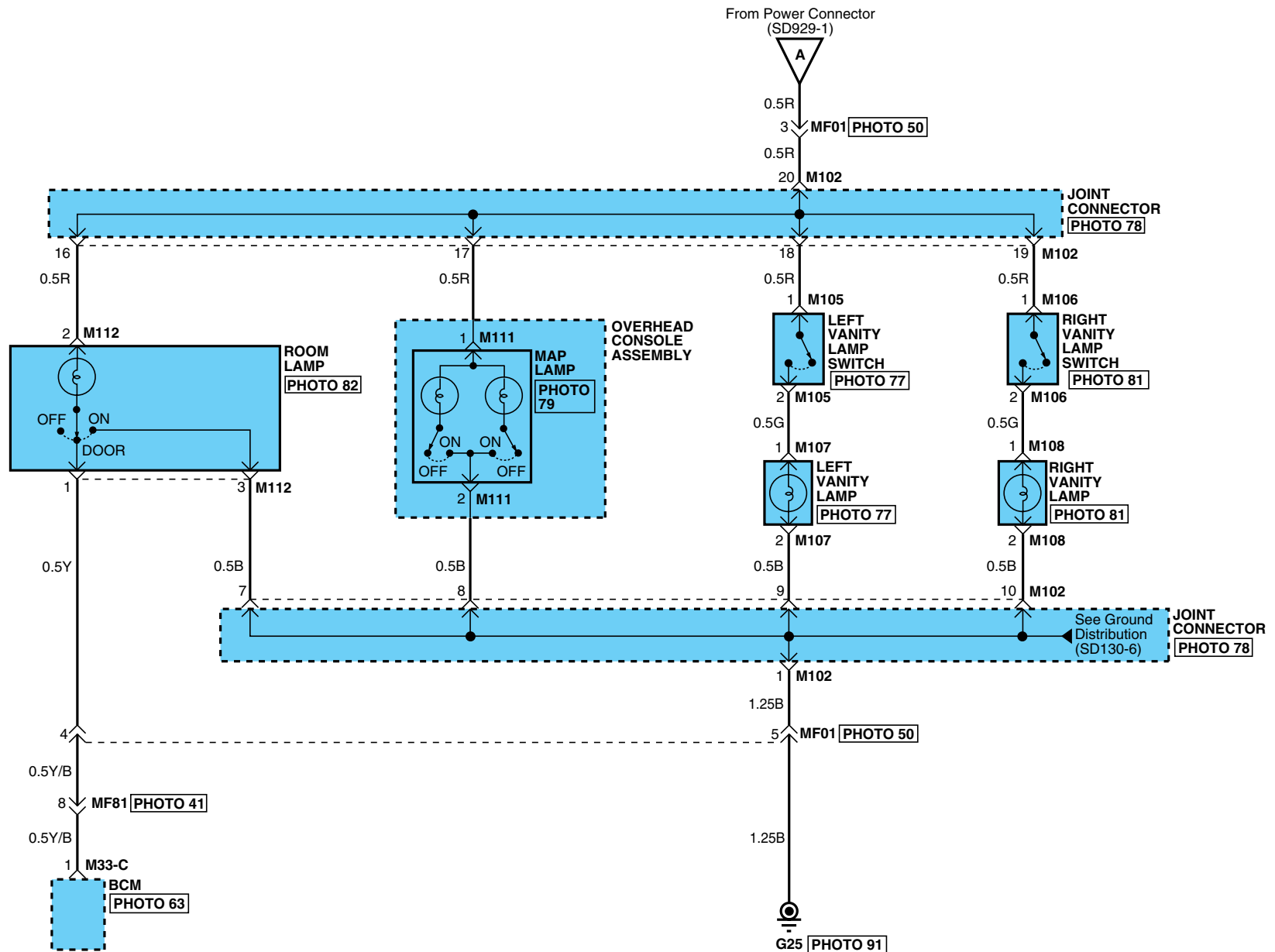

**COURTESY & TRUNK ROOM LAMPS**

**COURTESY & TRUNK ROOM LAMPS (3)**

**SD929-3**

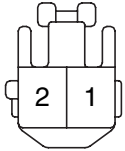
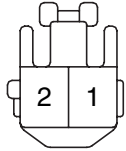
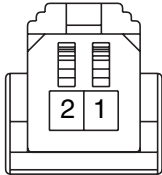
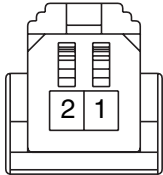
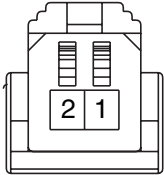
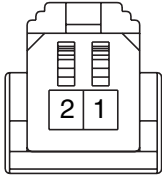
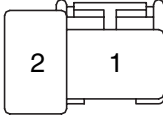
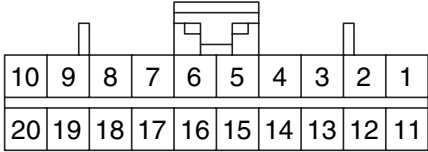
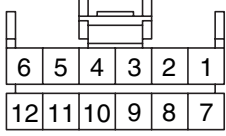
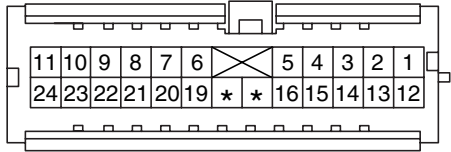
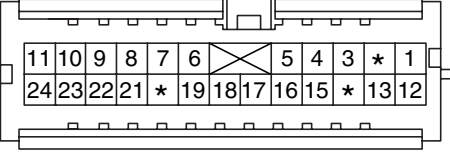
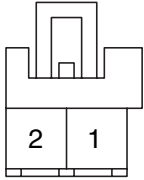
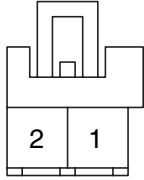
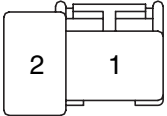
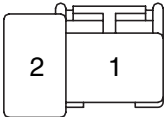
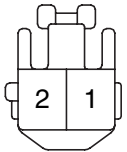
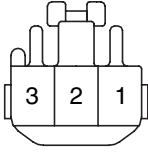
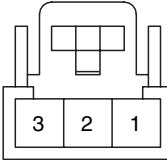
<p><b>D15</b></p>  <p>KET_090III_02F_W_L</p>	<p><b>D16</b></p>  <p>KET_090III_02F_W_L</p>	<p><b>F11</b></p>  <p>AMP_040M1_02F_W</p>	<p><b>F12</b></p>  <p>AMP_040M1_02F_W</p>
<p><b>F21</b></p>  <p>AMP_040M1_02F_W</p>	<p><b>F22</b></p>  <p>AMP_040M1_02F_W</p>	<p><b>F42</b></p>  <p>AMP_PLM2_02F_B</p>	<p><b>BLANK</b></p>
<p><b>M08-1</b></p>  <p>AMP_040M2_20F_B</p>	<p><b>M08-3</b></p>  <p>AMP_040M1_12F_B</p>	<p><b>M33-A</b></p>  <p>AMP_040III_24F_W</p>	<p><b>M33-C</b></p>  <p>AMP_040III_24F_GR</p>
<p><b>BLANK</b></p>	<p><b>M105</b></p>  <p>KUM_CDR_02F_B</p>	<p><b>M106</b></p>  <p>KUM_CDR_02F_B</p>	<p><b>M107</b></p>  <p>AMP_PLM2_02F_B</p>
<p><b>M108</b></p>  <p>AMP_PLM2_02F_B</p>	<p><b>M111</b></p>  <p>KET_090III_02F_W_L</p>	<p><b>M112</b></p>  <p>KET_090III_03F_W</p>	<p><b>R12</b></p>  <p>AMP_070_03F_W</p>



**COURTESY & TRUNK ROOM LAMPS**

**COURTESY & TRUNK ROOM LAMPS (4)**

**SD929-4**

**MEMO**

INDICATORS & GAUGES (1)

SD940-1

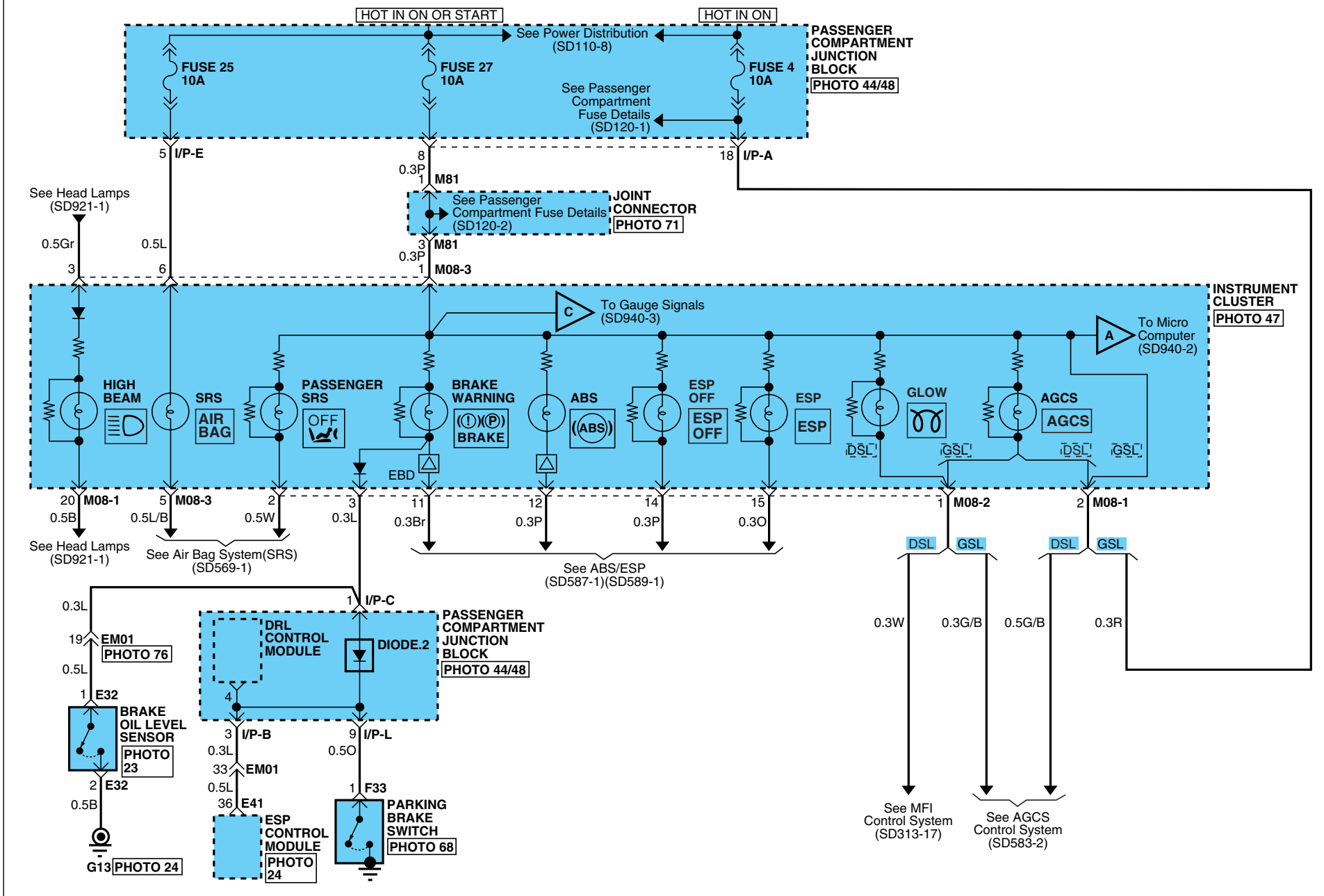

# INDICATORS & GAUGES

## INDICATORS & GAUGES (2)

SD940-2

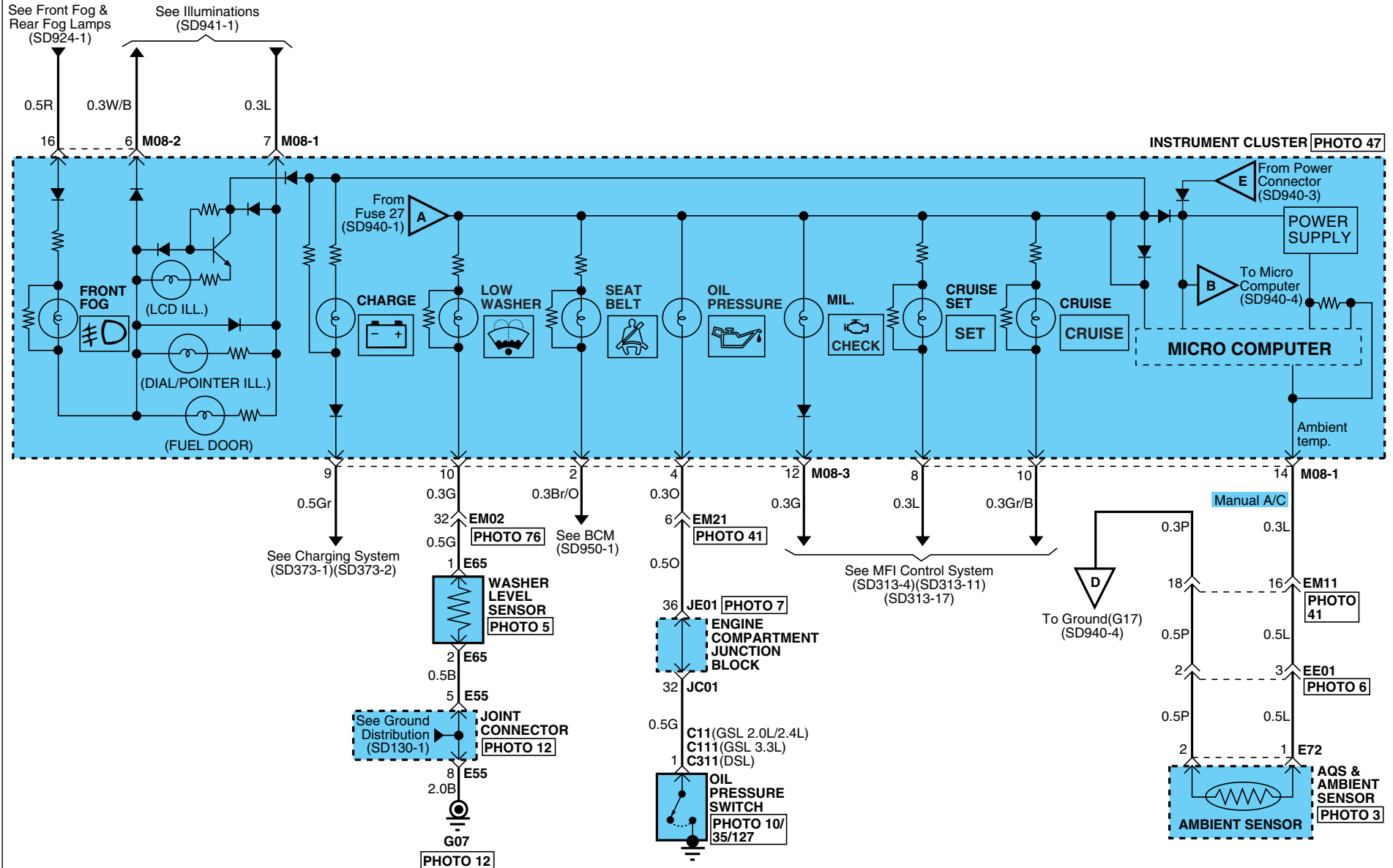

# INDICATORS & GAUGES

## INDICATORS & GAUGES (3)

SD940-3

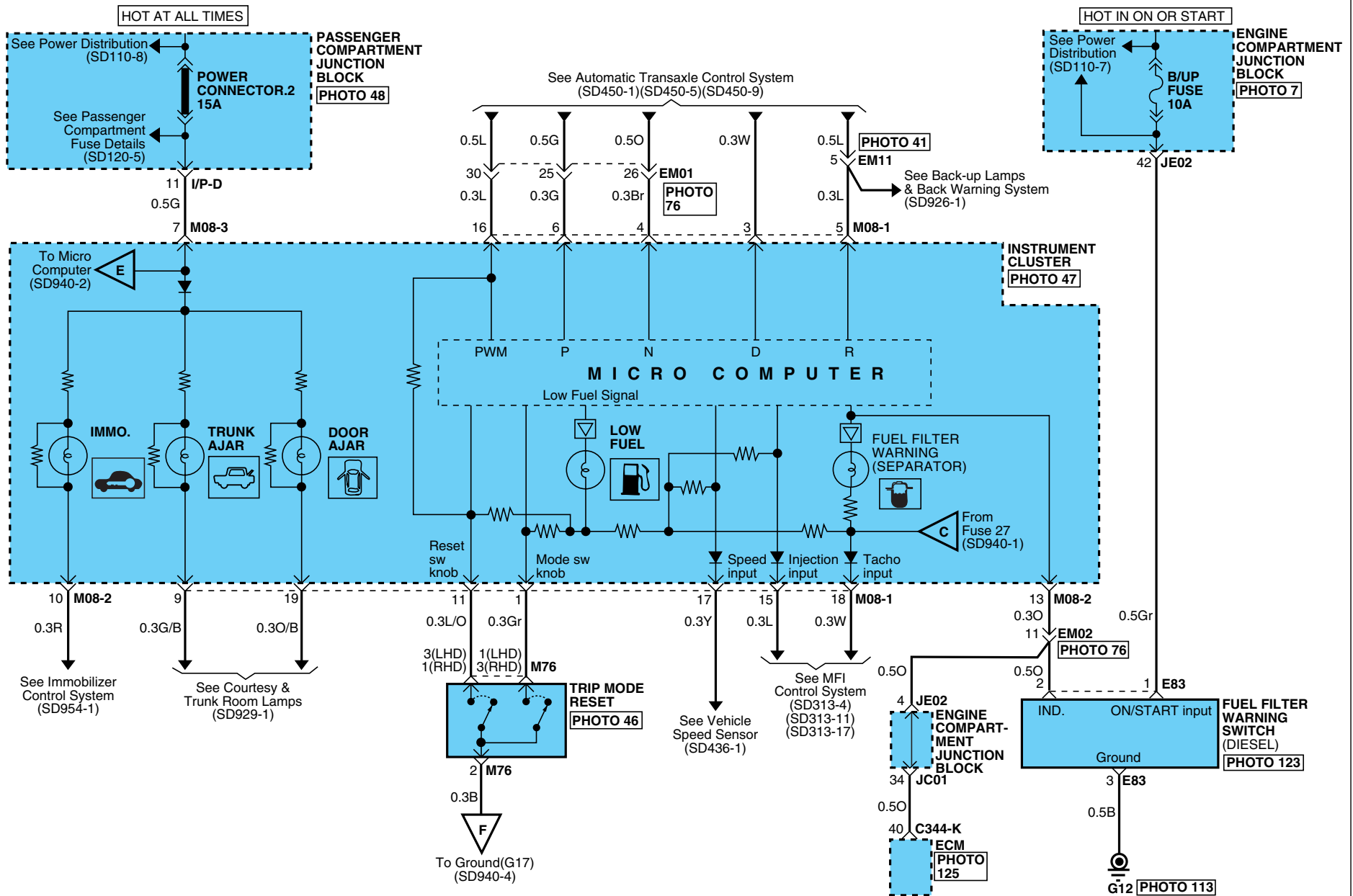





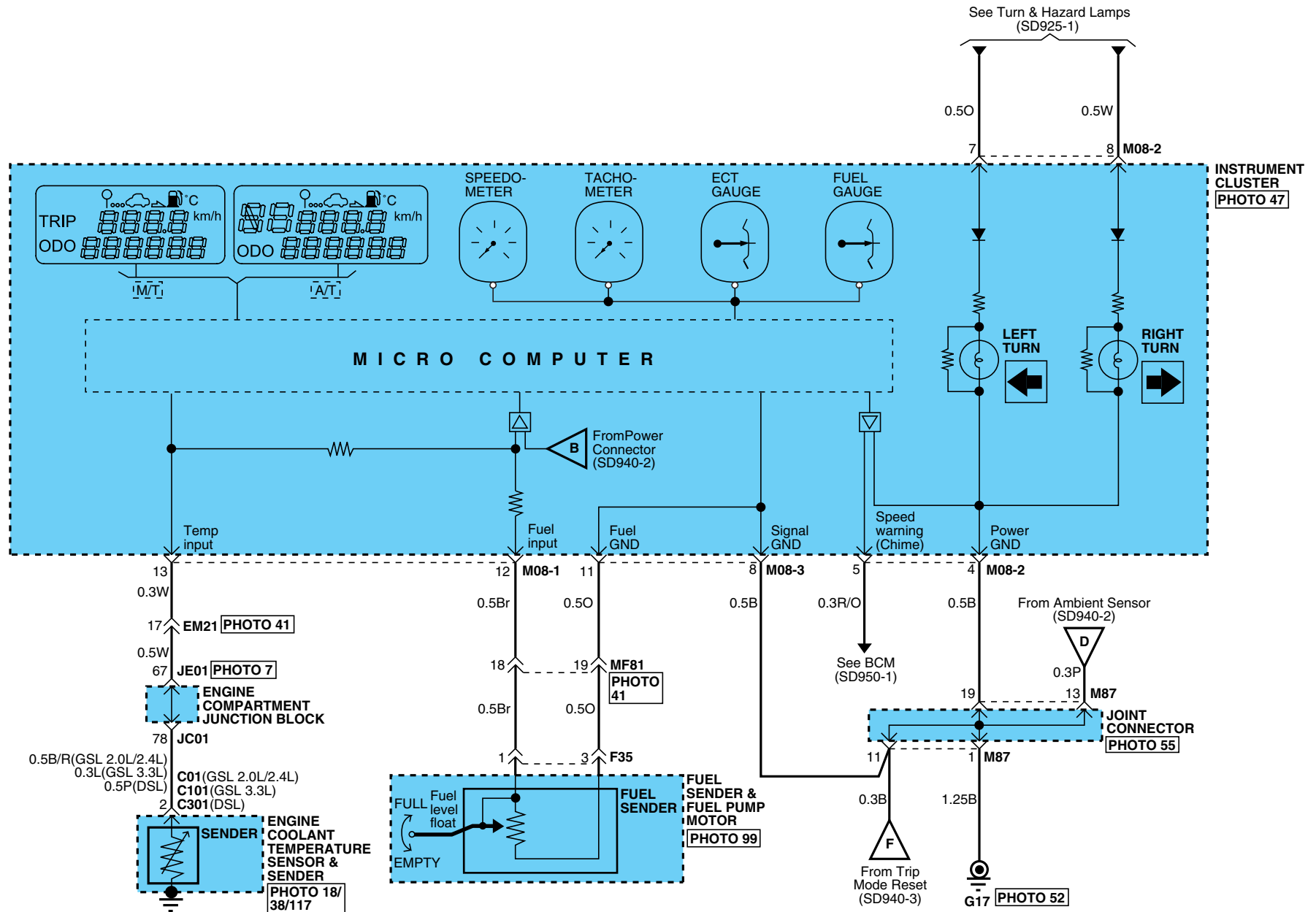

INDICATORS & GAUGES

INDICATORS & GAUGES (4)

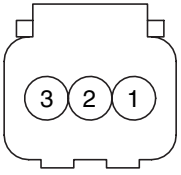
SD940-4

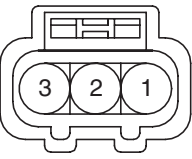

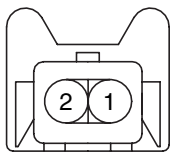
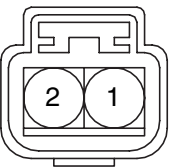
**INDICATORS & GAUGES**

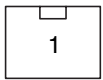
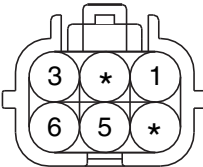
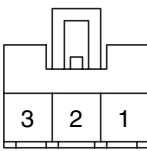
INDICATORS & GAUGES (5)			SD940-5																																				
<p><b>C01/C301</b></p>  <p>KUM_WTS_03F_B</p>	<p><b>C11/C111</b></p>  <p>KUM_NMWP_01F_B</p>	<p><b>C101</b></p>  <p>KUM_62Z_03F_B_WTS</p>	<p><b>C311</b></p>  <p>KUM_NMWP_01F_B</p>																																				
<p><b>E32</b></p>  <p>AMP_JPT_02F_B_CLIP</p>	<p><b>E65</b></p>  <p>KUM_NMWP_02F_B</p>	<p><b>E72</b></p>  <p>KET_090IWP_06F_B</p>	<p><b>E83</b></p>  <p>AMP_090WP_03F_B</p>																																				
<p><b>F33</b></p>  <p>AMP_PLM1_01F_B</p>	<p><b>F35</b></p>  <p>KET_SWP_06F_B</p>	<p><b>M08-1</b></p> <table border="1" data-bbox="1131 790 1556 949"> <tr> <td>10</td><td>9</td><td>8</td><td>7</td><td>6</td><td>5</td><td>4</td><td>3</td><td>2</td><td>1</td> </tr> <tr> <td>20</td><td>19</td><td>18</td><td>17</td><td>16</td><td>15</td><td>14</td><td>13</td><td>12</td><td>11</td> </tr> </table> <p>AMP_040M2_20F_B</p>	10	9	8	7	6	5	4	3	2	1	20	19	18	17	16	15	14	13	12	11	<p><b>M08-2</b></p> <table border="1" data-bbox="1702 821 1948 933"> <tr> <td>8</td><td>7</td><td>6</td><td>5</td><td>4</td><td>3</td><td>2</td><td>1</td> </tr> <tr> <td>16</td><td>15</td><td>14</td><td>13</td><td>12</td><td>11</td><td>10</td><td>*</td> </tr> </table> <p>AMP_040M2_16F_B</p>	8	7	6	5	4	3	2	1	16	15	14	13	12	11	10	*
10	9	8	7	6	5	4	3	2	1																														
20	19	18	17	16	15	14	13	12	11																														
8	7	6	5	4	3	2	1																																
16	15	14	13	12	11	10	*																																
<p><b>M08-3</b></p> <table border="1" data-bbox="291 1069 515 1212"> <tr> <td>6</td><td>5</td><td>4</td><td>3</td><td>2</td><td>1</td> </tr> <tr> <td>12</td><td>11</td><td>10</td><td>9</td><td>8</td><td>7</td> </tr> </table> <p>AMP_040M1_12F_B</p>	6	5	4	3	2	1	12	11	10	9	8	7	<p><b>M76</b></p>  <p>KUM_CDR_03F_W</p>	<p><b>BLANK</b></p>	<p><b>BLANK</b></p>																								
6	5	4	3	2	1																																		
12	11	10	9	8	7																																		

**INDICATORS & GAUGES**

**INDICATORS & GAUGES (6)**

**SD940-6**

**MEMO**

ILLUMINATIONS (1)

SD941-1

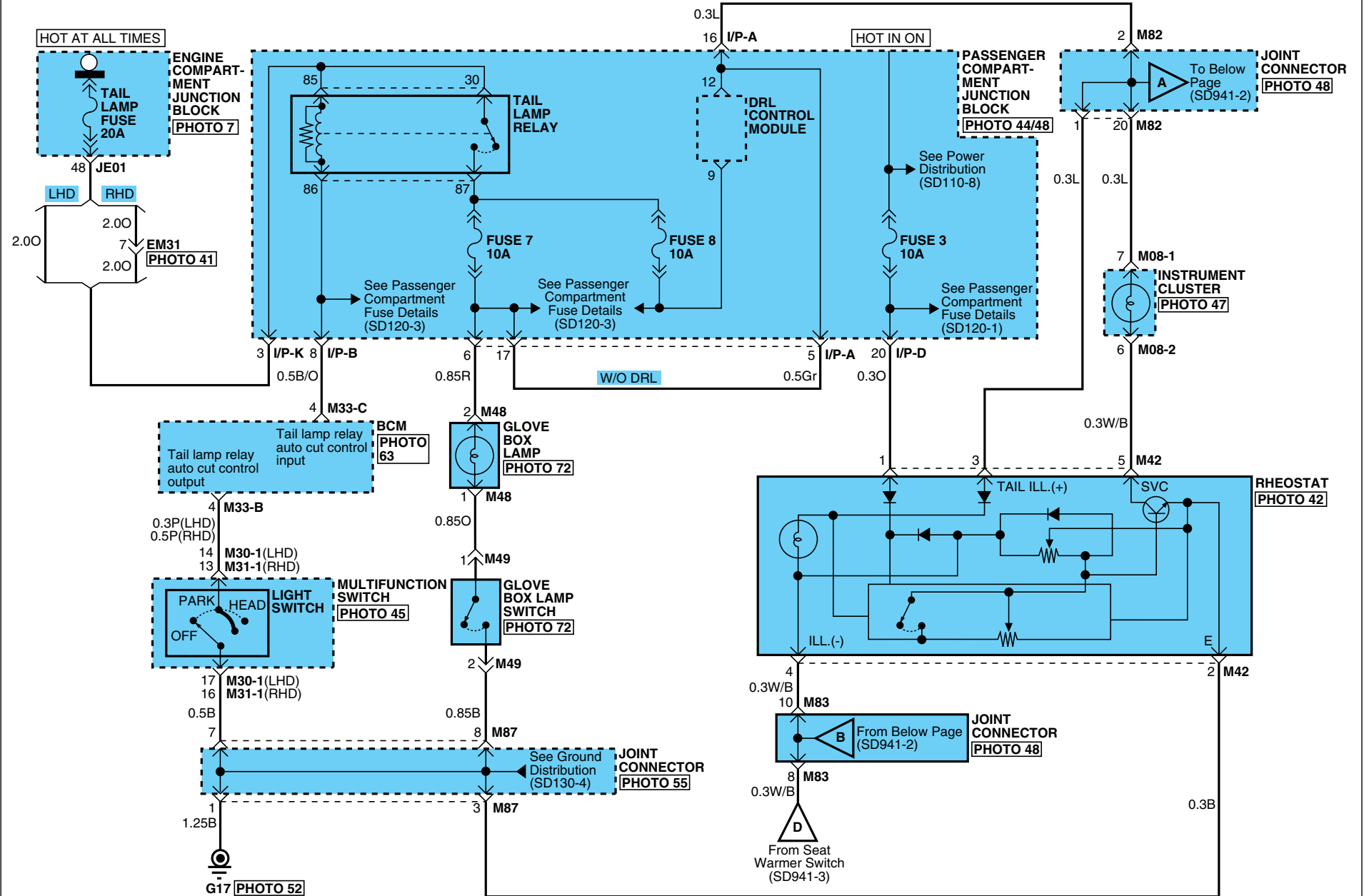



# ILLUMINATIONS

## ILLUMINATIONS (2)

SD941-2

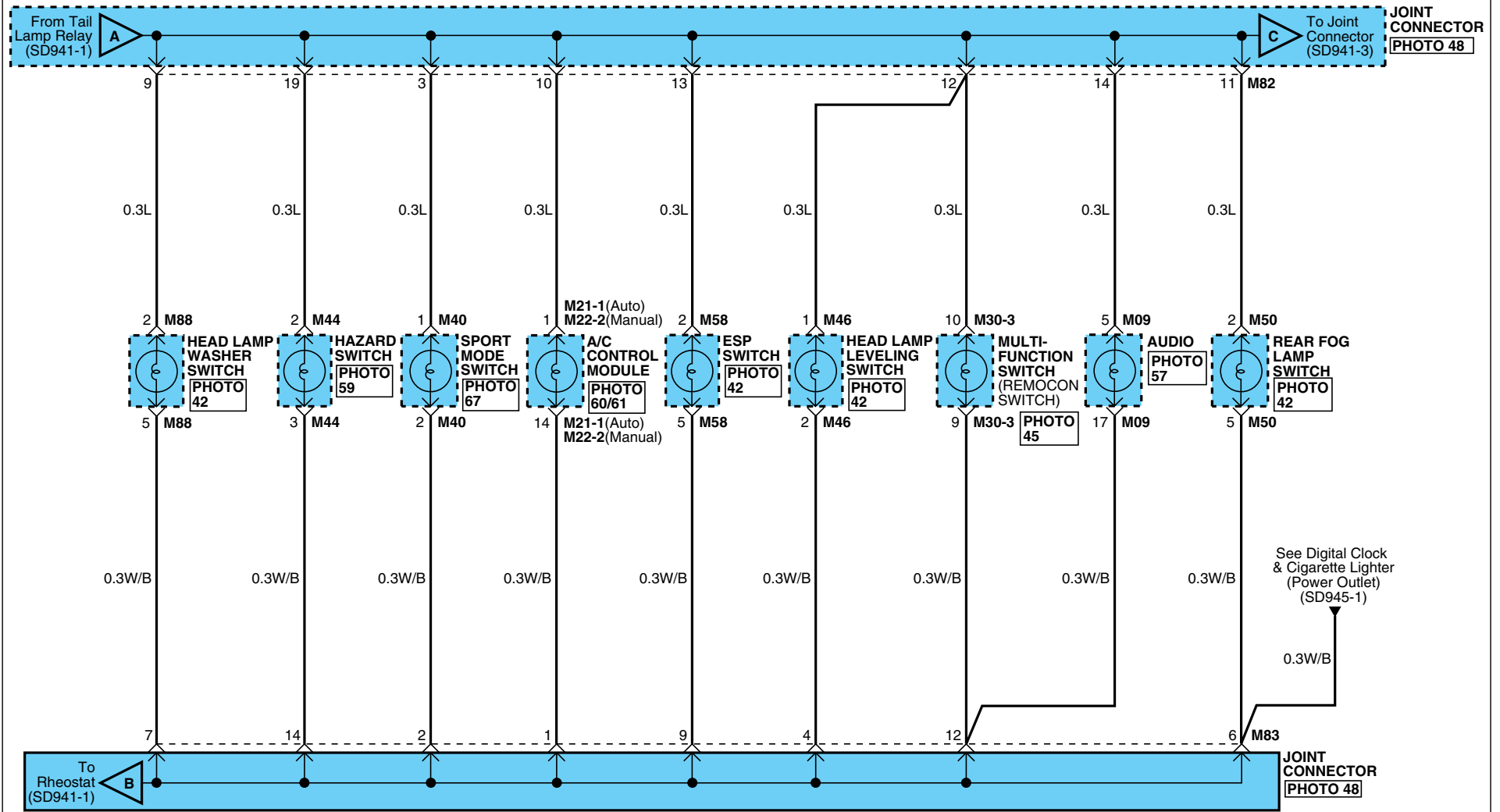

# ILLUMINATIONS

## ILLUMINATIONS (3)

SD941-3

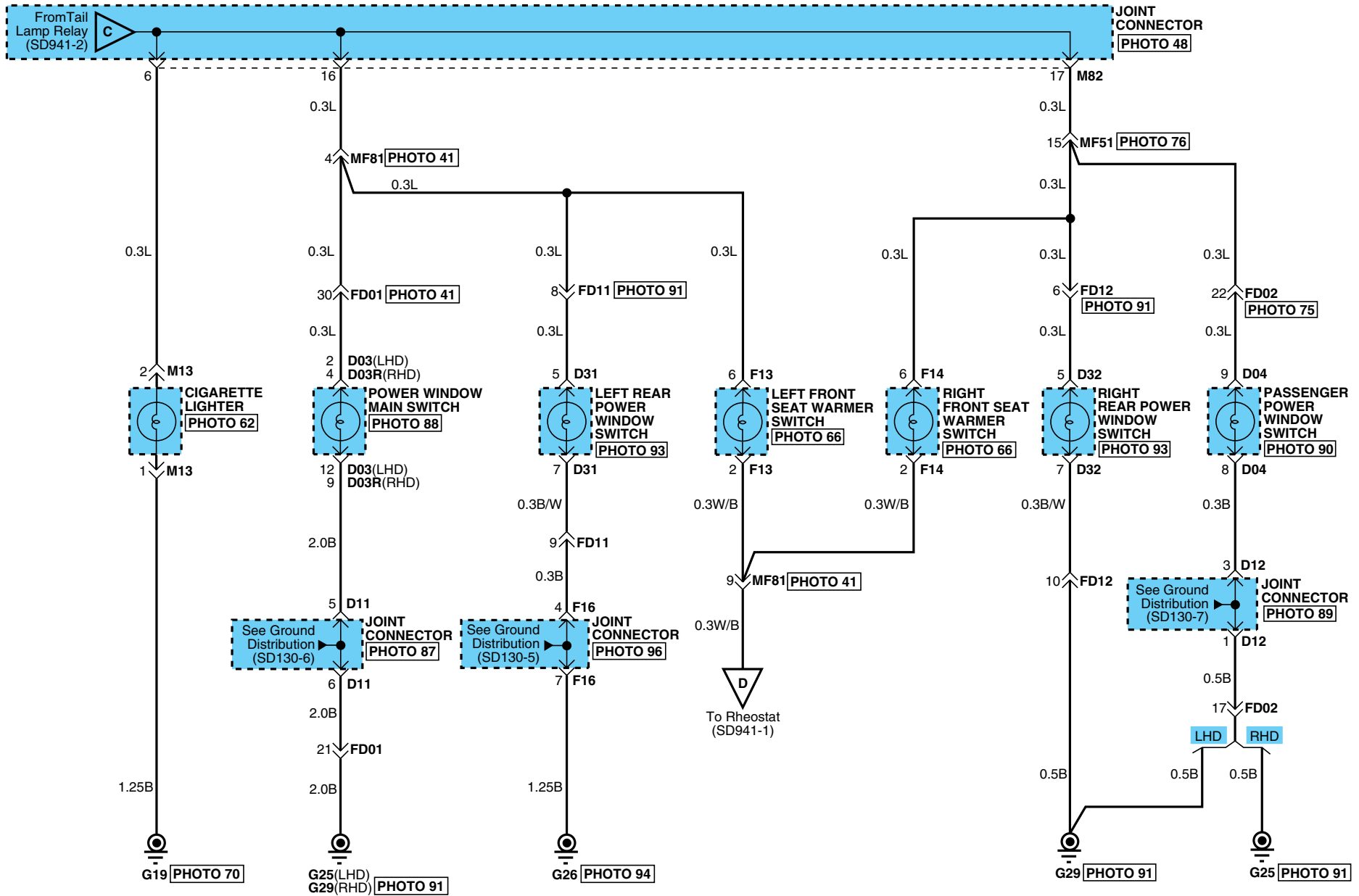

# ILLUMINATIONS

ILLUMINATIONS (4)			SD941-4
<p><b>D03/D03R</b></p> <p>KET_090III_14F_W</p>	<p><b>D04</b></p> <p>KET_090II_11F_W</p>	<p><b>D31/D32</b></p> <p>KET_090III_08F_W</p>	<p><b>F13</b></p> <p>KET_090III_06F_Y</p>
<p><b>F14</b></p> <p>KET_090III_06F_L</p>	<p><b>M09</b></p> <p>KET_0409_24F_W</p>	<p><b>M13</b></p> <p>KET_090III_03F_W</p>	<p><b>M30-1</b></p> <p>KET_0509_18F_W</p>
<p><b>M30-3</b></p> <p>AMP_025_12F_W</p>	<p><b>M31-1</b></p> <p>KET_0509_18F_W</p>	<p><b>M40</b></p> <p>KET_090II_11F_W</p>	<p><b>M42</b></p> <p>KET_090III_06F_B</p>
<p><b>M44</b></p> <p>KET_090III_10F_W</p>	<p><b>M46</b></p> <p>KUM_CDR_05F_W</p>	<p><b>M48</b></p> <p>AMP_PLM2_02F_B</p>	<p><b>M49</b></p> <p>KET_187_02F_W</p>
<p><b>M50</b></p> <p>KET_090III_06F_Br</p>	<p><b>M58</b></p> <p>KET_090III_06F_G</p>	<p><b>M88</b></p> <p>KET_090III_06F_Gr</p>	<p><b>BLANK</b></p>

DIGITAL CLOCK & CIGARETTE LIGHTER (POWER OUTLET) (1)

SD945-1

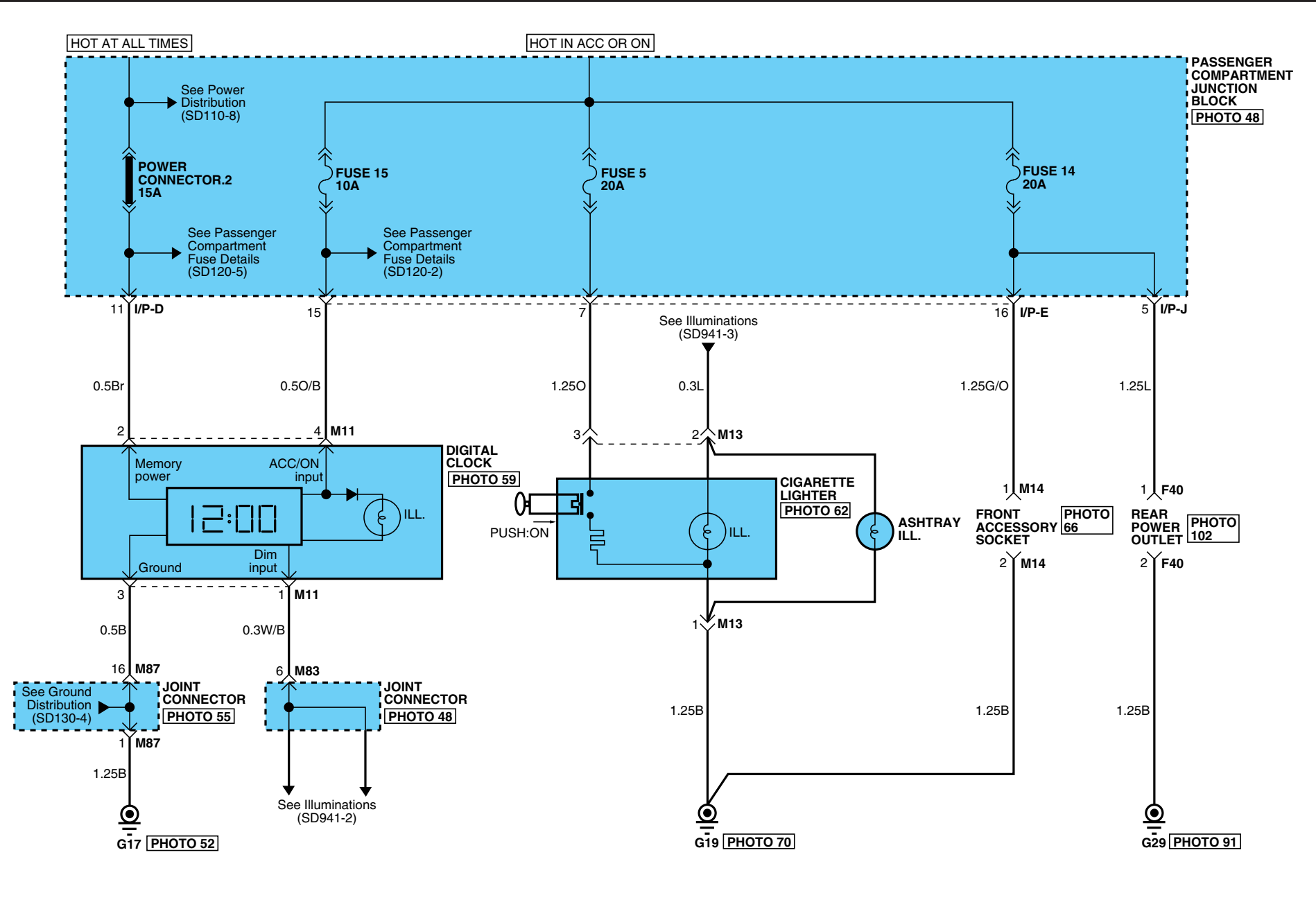

**DIGITAL CLOCK & CIGARETTE LIGHTER (POWER OUTLET)**

**DIGITAL CLOCK & CIGARETTE LIGHTER (POWER OUTLET) (2)**

**SD945-2**

**F40**

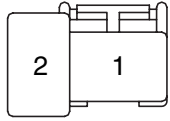

AMP\_PLM2\_02F\_B

**M11**

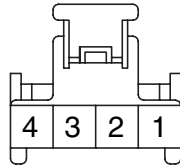

KUM\_AR\_04F\_W

**M13**

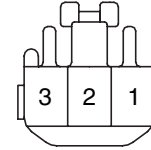

KET\_090III\_03F\_W

**M14**

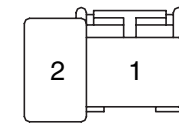

AMP\_PLM2\_02F\_B

**BODY CONTROL MODULE (BCM) SYSTEM** E98FEB2F

**BODY CONTROL MODULE (BCM) SYSTEM (1)**

**SD950-1**

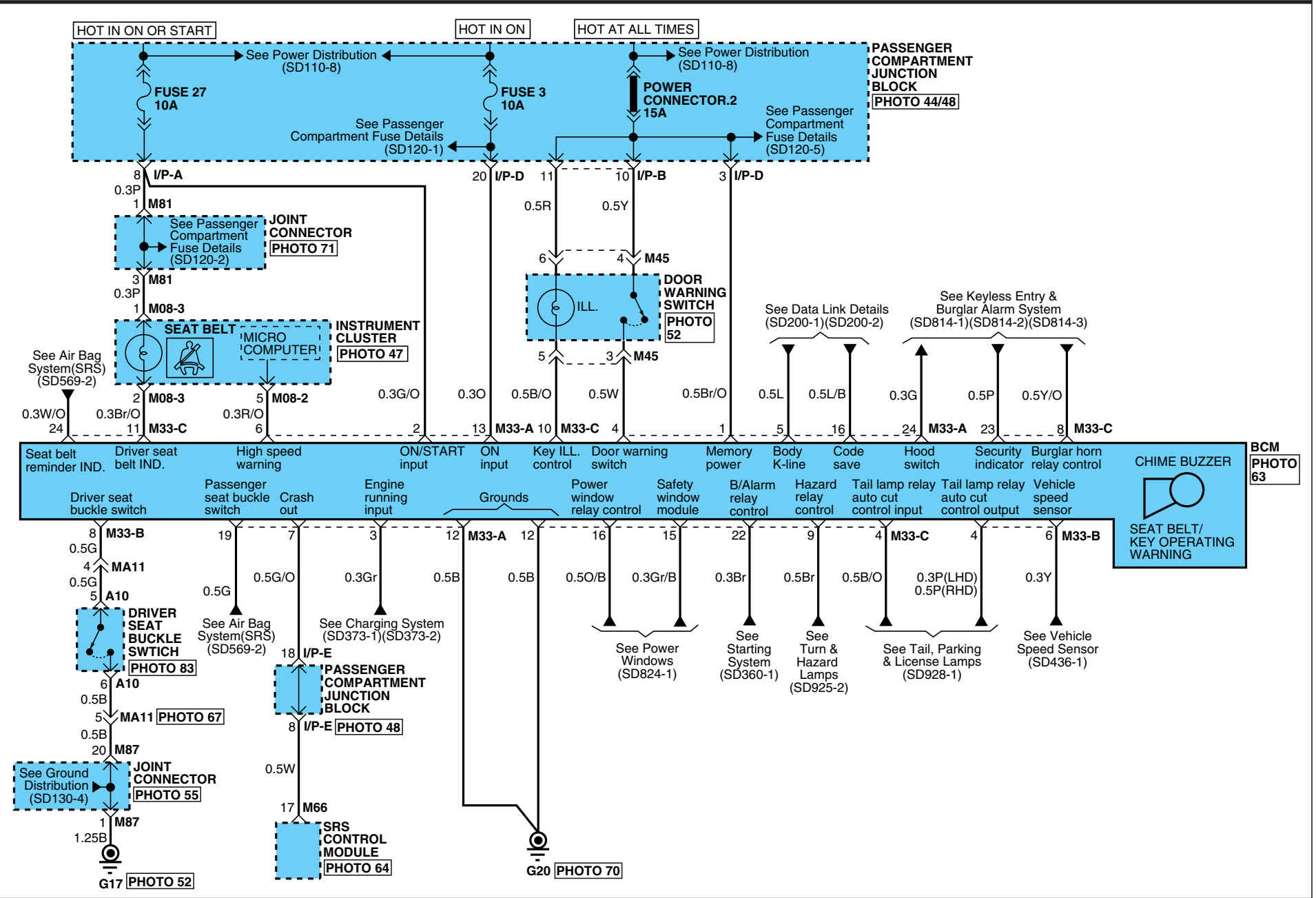

# BODY CONTROL MODULE (BCM) SYSTEM

## BODY CONTROL MODULE (BCM) SYSTEM (2)

SD950-2

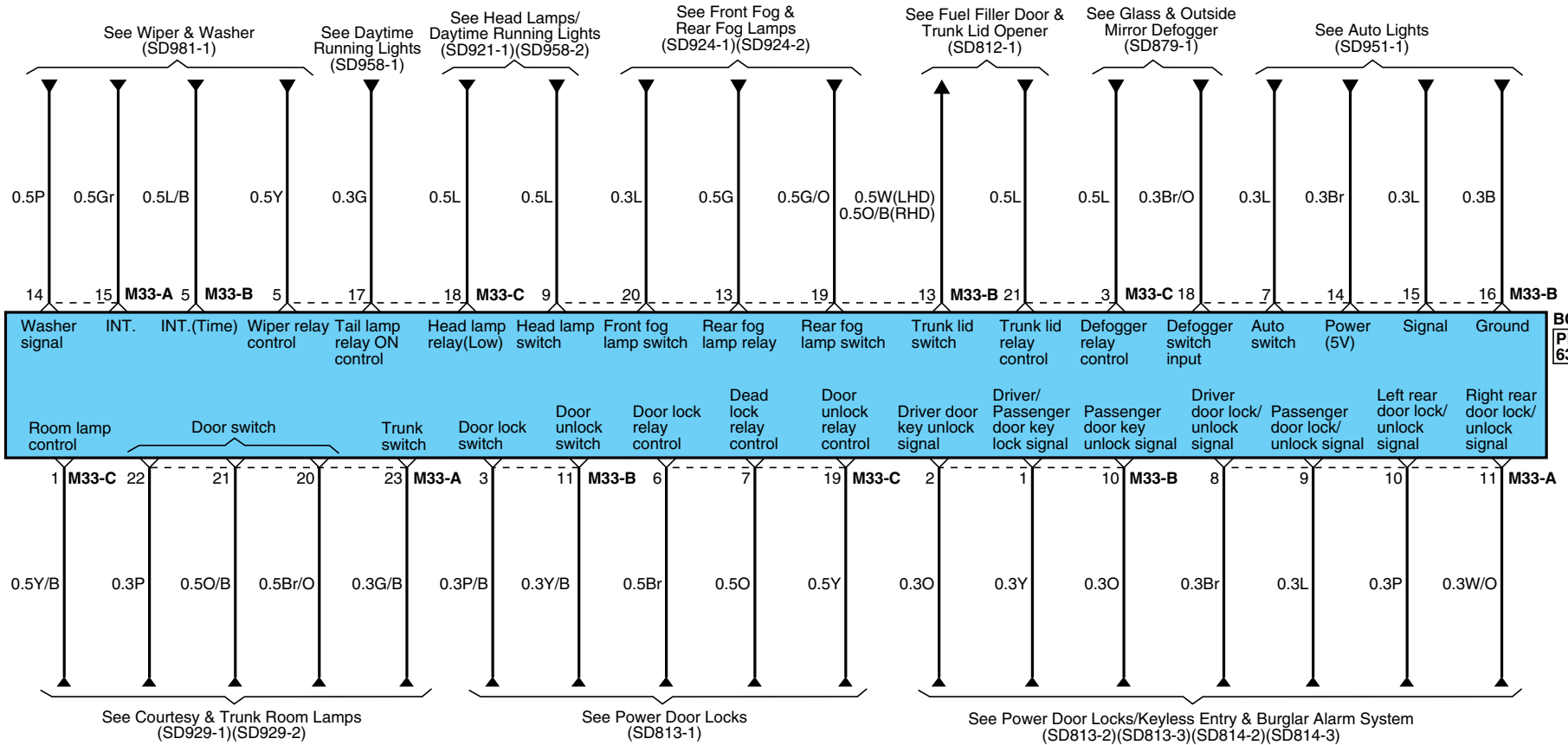

BCM  
PHOTO  
63

# BODY CONTROL MODULE (BCM) SYSTEM

## BODY CONTROL MODULE (BCM) SYSTEM (3)

SD950-3

**A10**

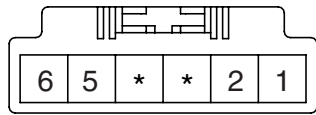

AMP\_ABAG\_06F\_Y

**M08-2**

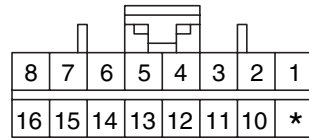

AMP\_040M2\_16F\_B

**M08-3**

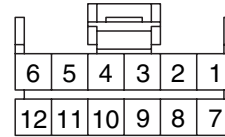

AMP\_040M1\_12F\_B

**M33-A**

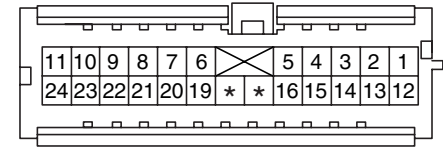

AMP\_040III\_24F\_W

**M33-B**

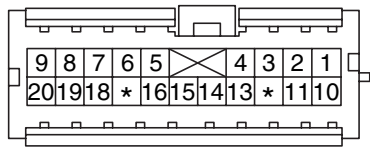

AMP\_040III\_20F\_W

**M33-C**

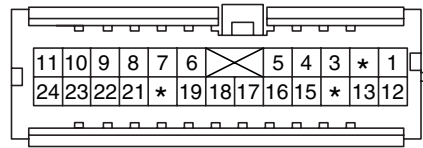

AMP\_040III\_24F\_GR

**M45**

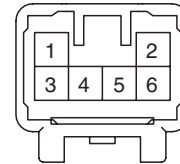

KET\_090III\_06M\_W

**M66**

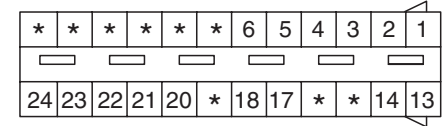

AMP\_ABG\_24F\_B\_ECU



## BODY CONTROL MODULE (BCM) SYSTEM

BODY CONTROL MODULE (BCM) SYSTEM (4)

SD950-4

MEMO

AUTO LIGHTS (1)

SD951-1

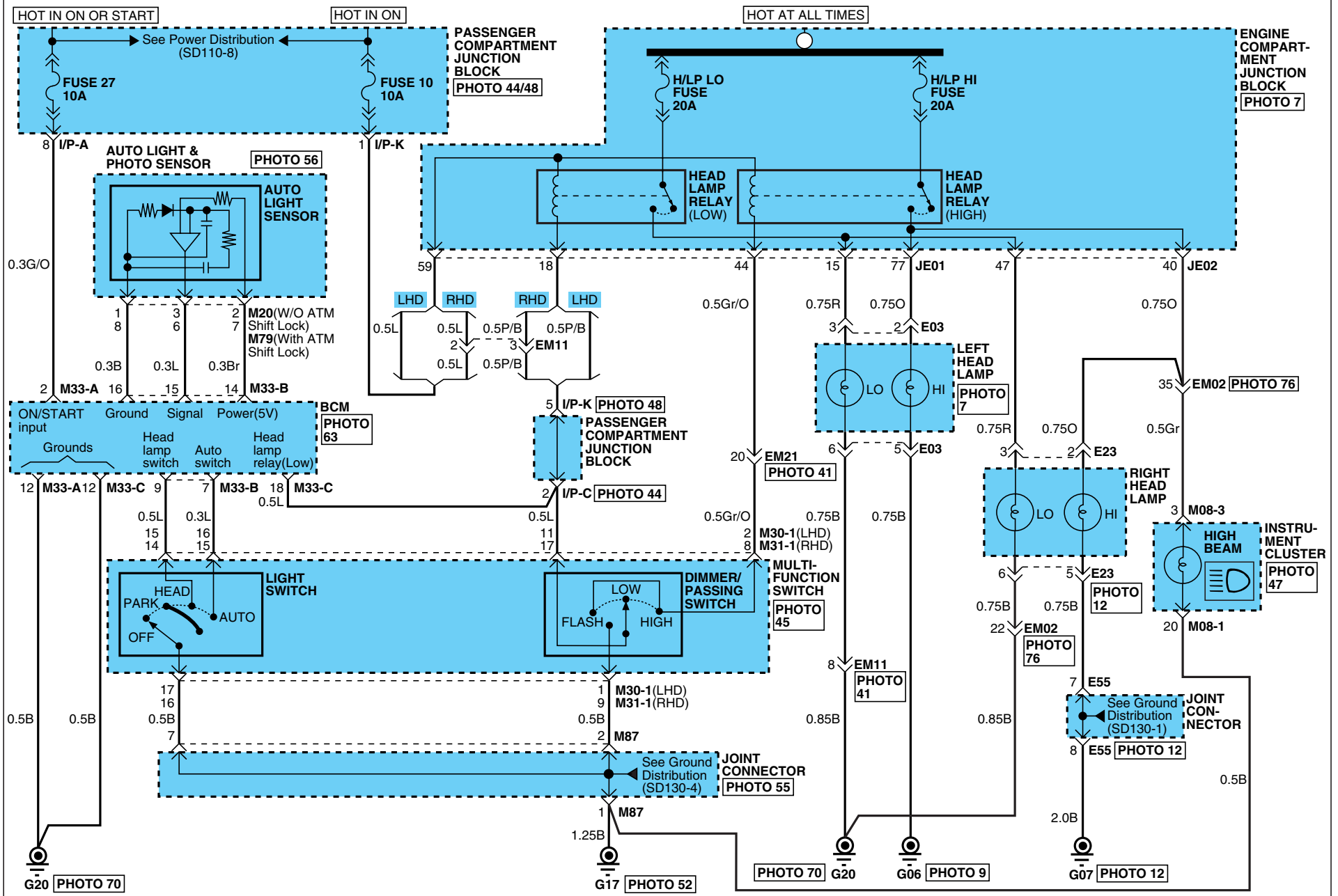

# AUTO LIGHTS

## AUTO LIGHTS (2)

SD951-2

**E03**

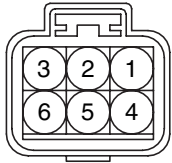

KUM\_NMWP\_06F\_B

**E23**



KUM\_NMWP\_06F\_B

**M08-1**

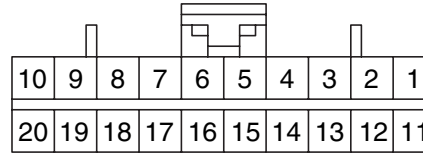

AMP\_040M2\_20F\_B

**M08-3**

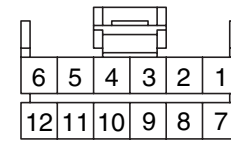

AMP\_040M1\_12F\_B

**M20**

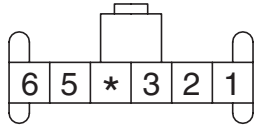

KET\_91A\_06F\_W

**M30-1**

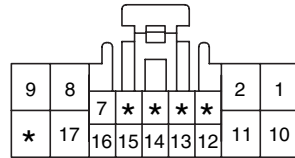

KET\_0509\_18F\_W

**M31-1**

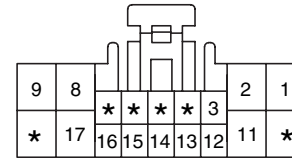

KET\_0509\_18F\_W

**M33-A**

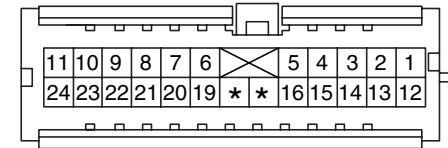

AMP\_040III\_24F\_W

**M33-B**

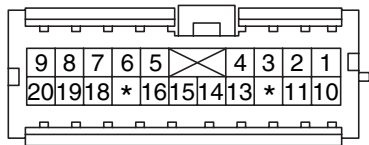

AMP\_040III\_20F\_W

**M33-C**

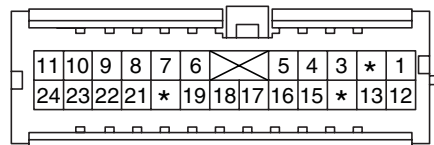

AMP\_040III\_24F\_GR

**M79**

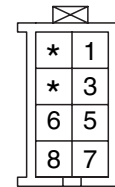

KET\_030\_08F\_GR

**BLANK**

IMMOBILIZER CONTROL SYSTEM (1)

SD954-1

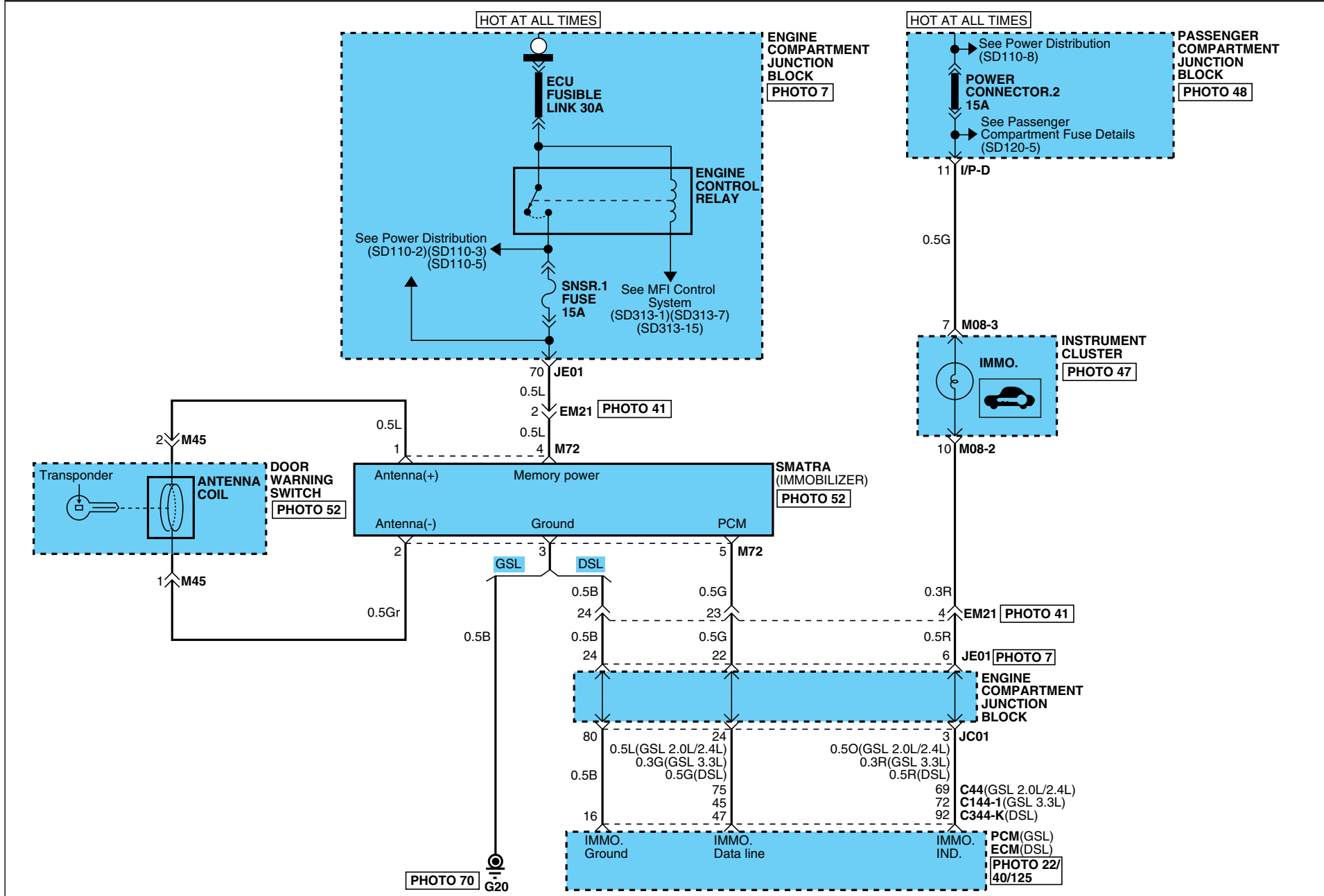

# IMMOBILIZER CONTROL SYSTEM

## IMMOBILIZER CONTROL SYSTEM (2)

SD954-2

**M08-2**

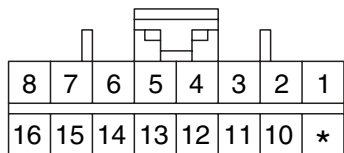

AMP\_040M2\_16F\_B

**M08-3**

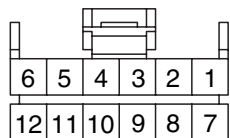

AMP\_040M1\_12F\_B

**M45**

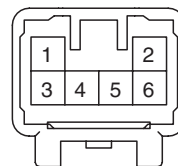

KET\_090III\_06M\_W

**M72**

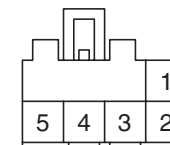

KUM\_CDR\_05F\_W

DAYTIME RUNNING LIGHTS (1)

SD958-1

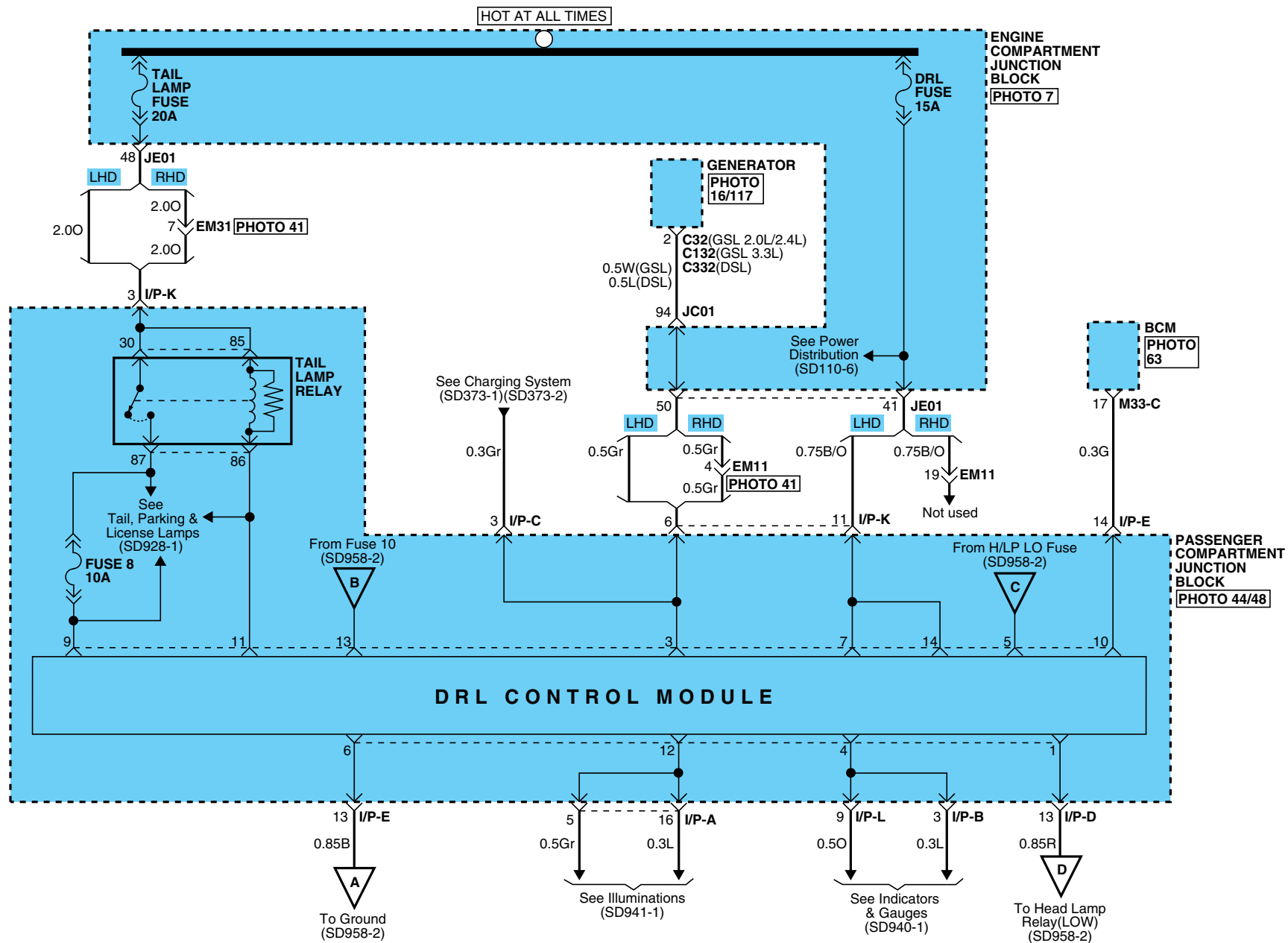



# DAYTIME RUNNING LIGHTS

## DAYTIME RUNNING LIGHTS (3)

SD958-3

**C32/C132**

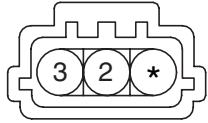

SUM\_ALTWP\_03F\_B

**C332**

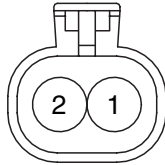

KET\_58X\_02F\_B

**E03**

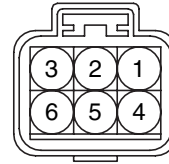

KUM\_NMWP\_06F\_B

**E23**

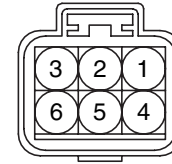

KUM\_NMWP\_06F\_B

**M08-1**

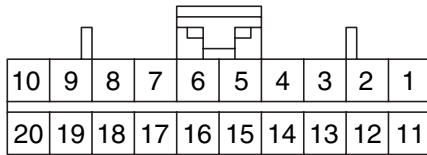

AMP\_040M2\_20F\_B

**M08-3**

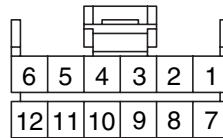

AMP\_040M1\_12F\_B

**M30-1**

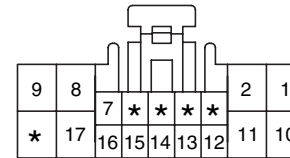

KET\_0509\_18F\_W

**M31-1**

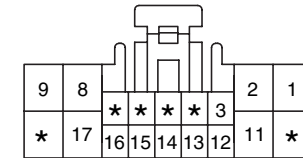

KET\_0509\_18F\_W

**M33-B**

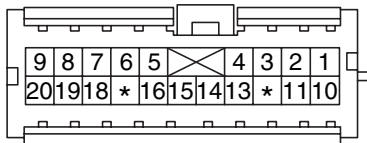

AMP\_040III\_20F\_W

**M33-C**

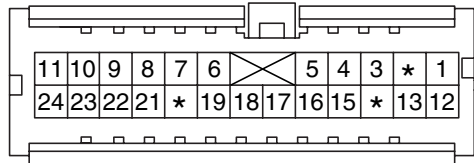

AMP\_040III\_24F\_GR

**BLANK**



**DAYTIME RUNNING LIGHTS**

**DAYTIME RUNNING LIGHTS (4)**

**SD958-4**

**MEMO**

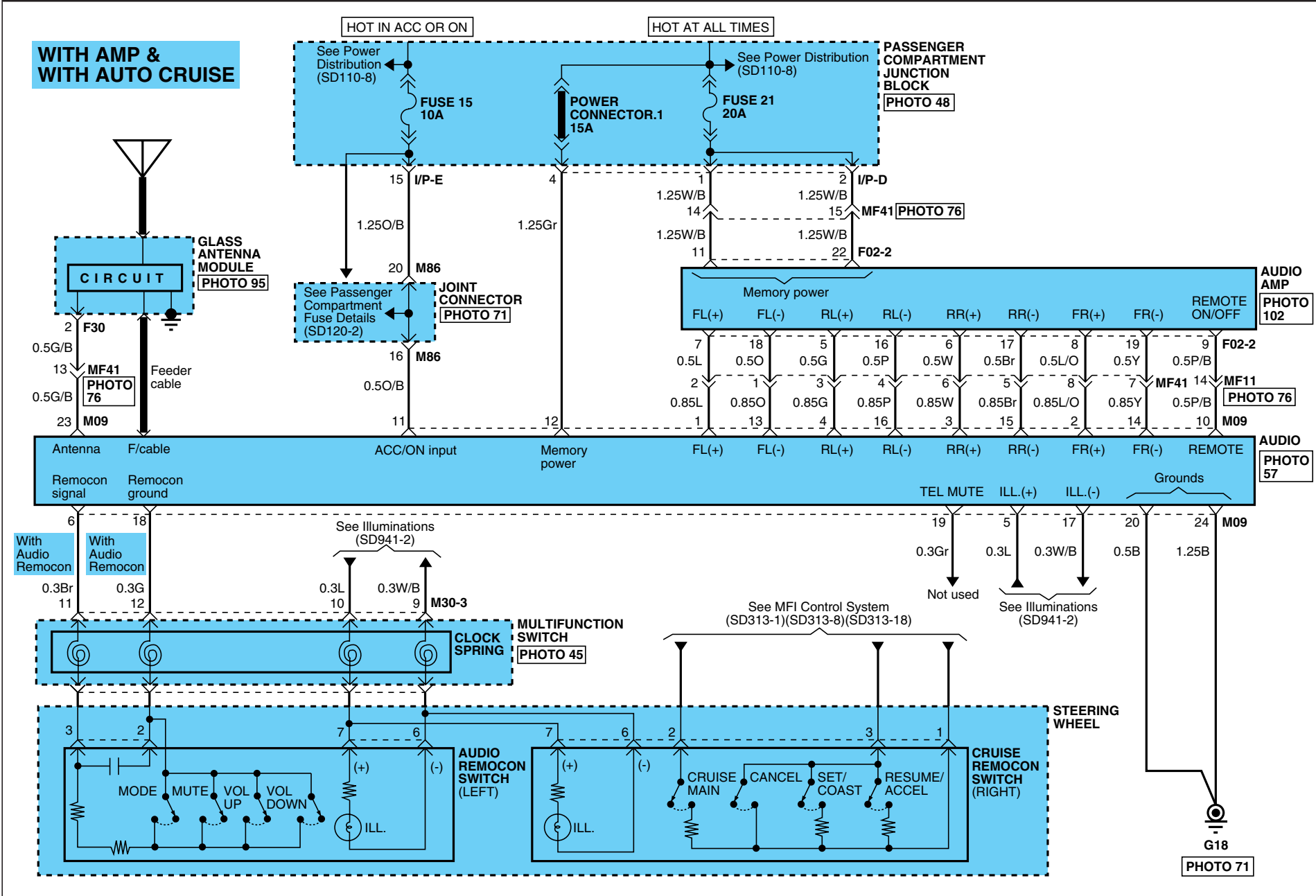

# AUDIO SYSTEM

## AUDIO SYSTEM (2)

SD961-2

**WITH AMP &  
WITH AUTO CRUISE**

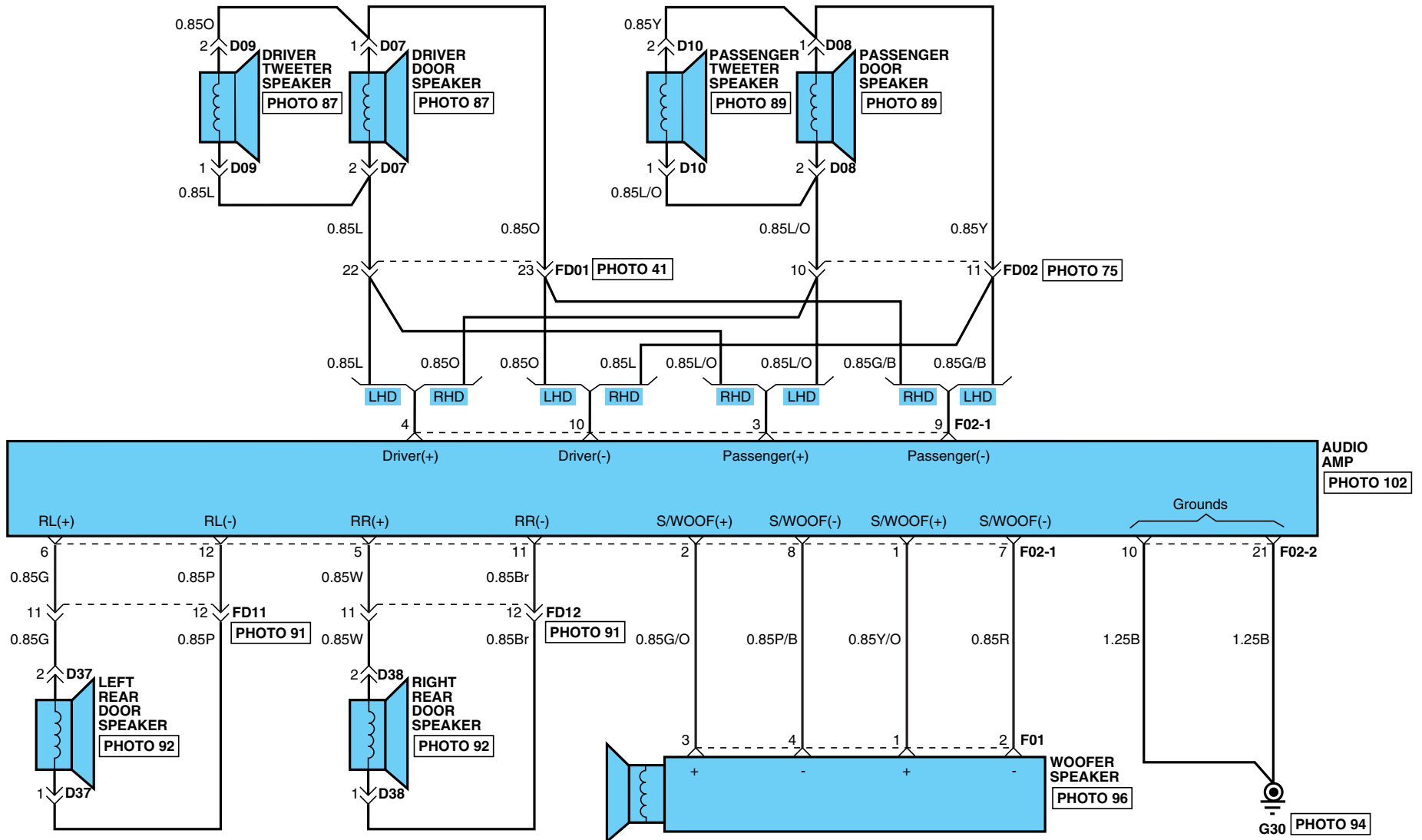

# AUDIO SYSTEM

## AUDIO SYSTEM (3)

SD961-3

**WITH AMP & W/O AUTO CRUISE**

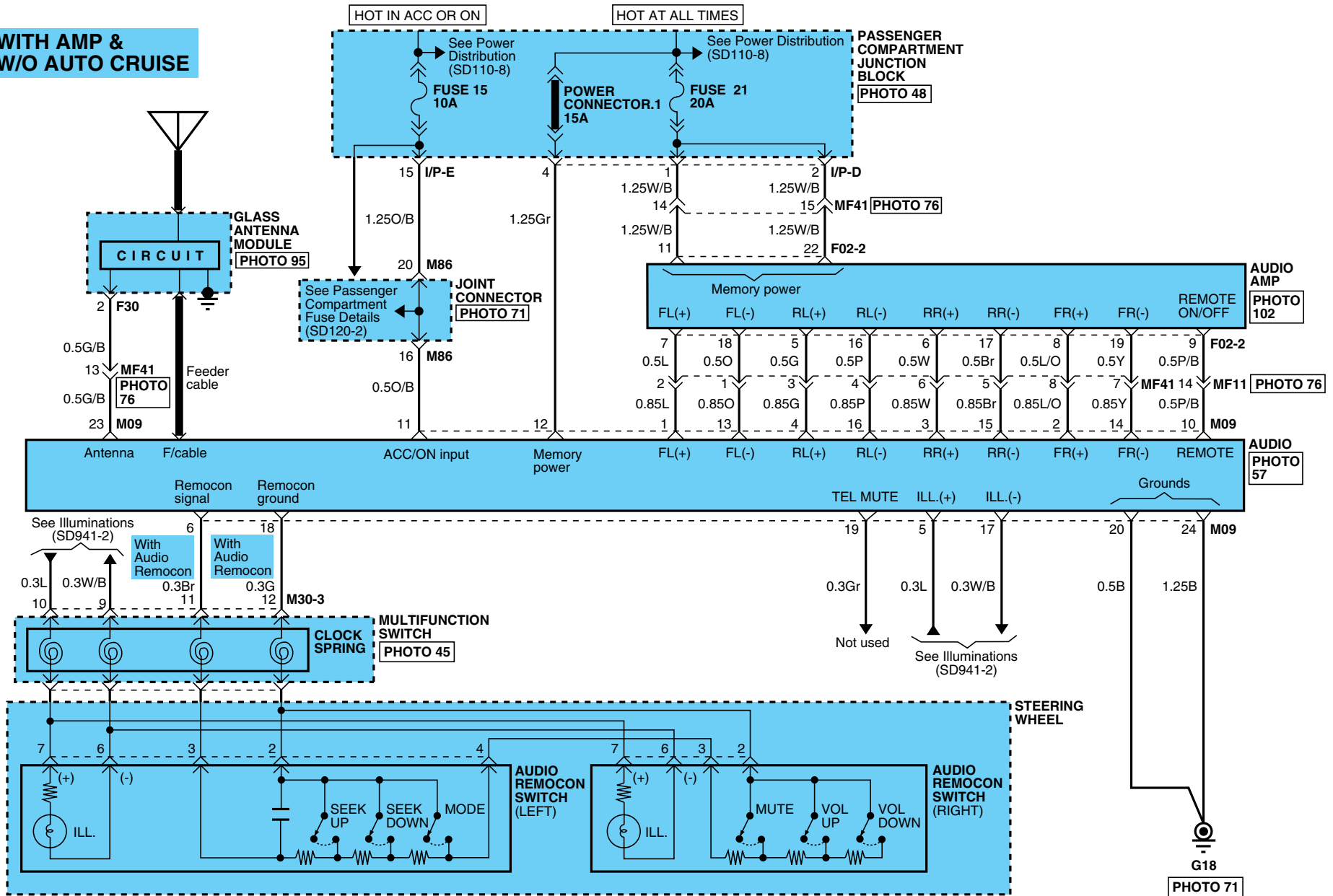

# AUDIO SYSTEM

## AUDIO SYSTEM (4)

SD961-4

**WITH AMP &  
W/O AUTO CRUISE**

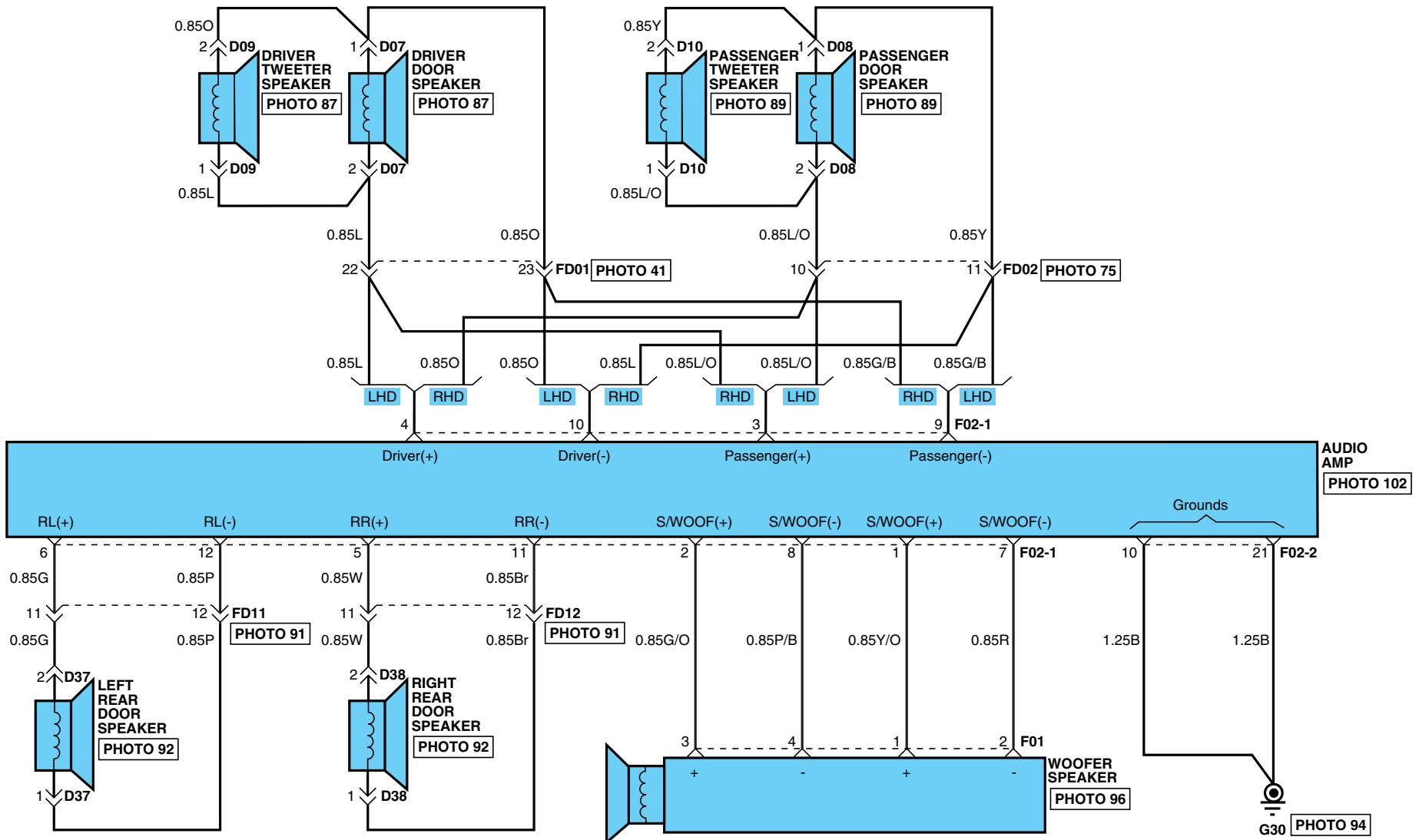

# AUDIO SYSTEM

## AUDIO SYSTEM (5)

SD961-5

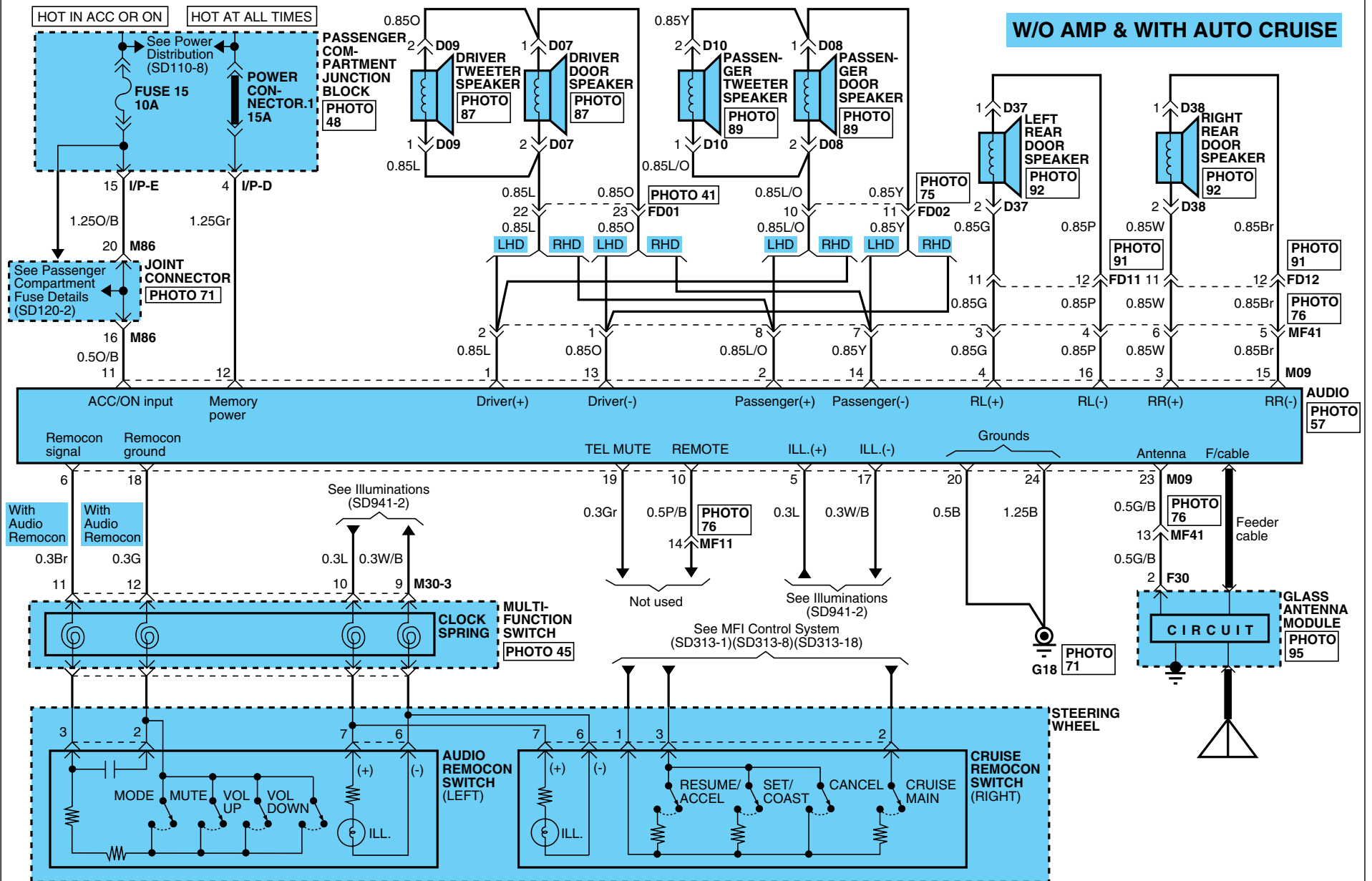

AUDIO SYSTEM

AUDIO SYSTEM (6)

SD961-6

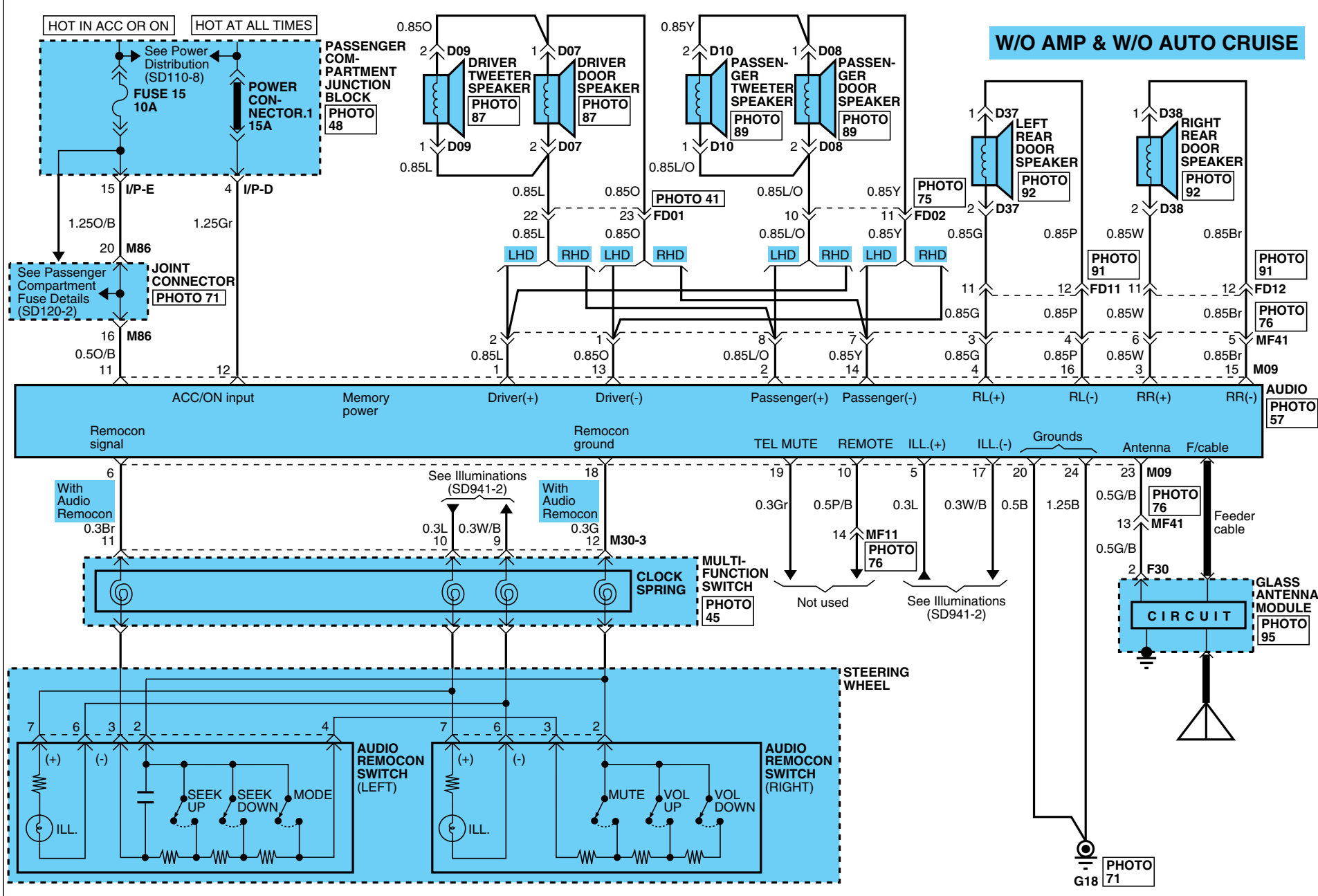

W/O AMP & W/O AUTO CRUISE

# AUDIO SYSTEM

## AUDIO SYSTEM (7)

SD961-7

**D07/D08**

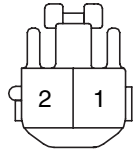

KET\_090III\_02F\_W\_L

**D09/D10**

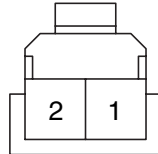

AMP\_070\_02F\_W

**D37/D38**

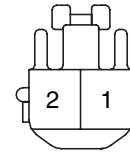

KET\_090III\_02F\_W\_L

**F01**

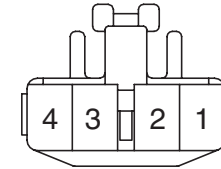

KET\_090III\_04F\_W

**F02-1**

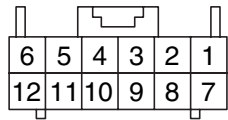

AMP\_0407\_12F\_W\_070

**F02-2**

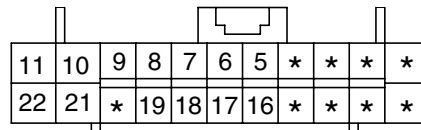

AMP\_0407\_22F\_W\_HD

**F30**

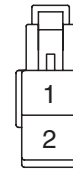

KET\_GLASS\_02F\_B\_ANT

**M09**

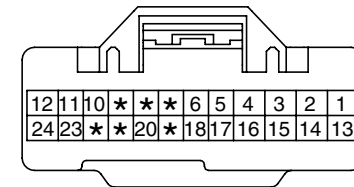

KET\_0409\_24F\_W

**M30-3**

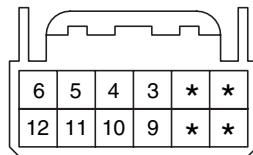

AMP\_025\_12F\_W

**BLANK**

**BLANK**

**BLANK**



**AUDIO SYSTEM**

**AUDIO SYSTEM (8)**

**SD961-8**

**MEMO**

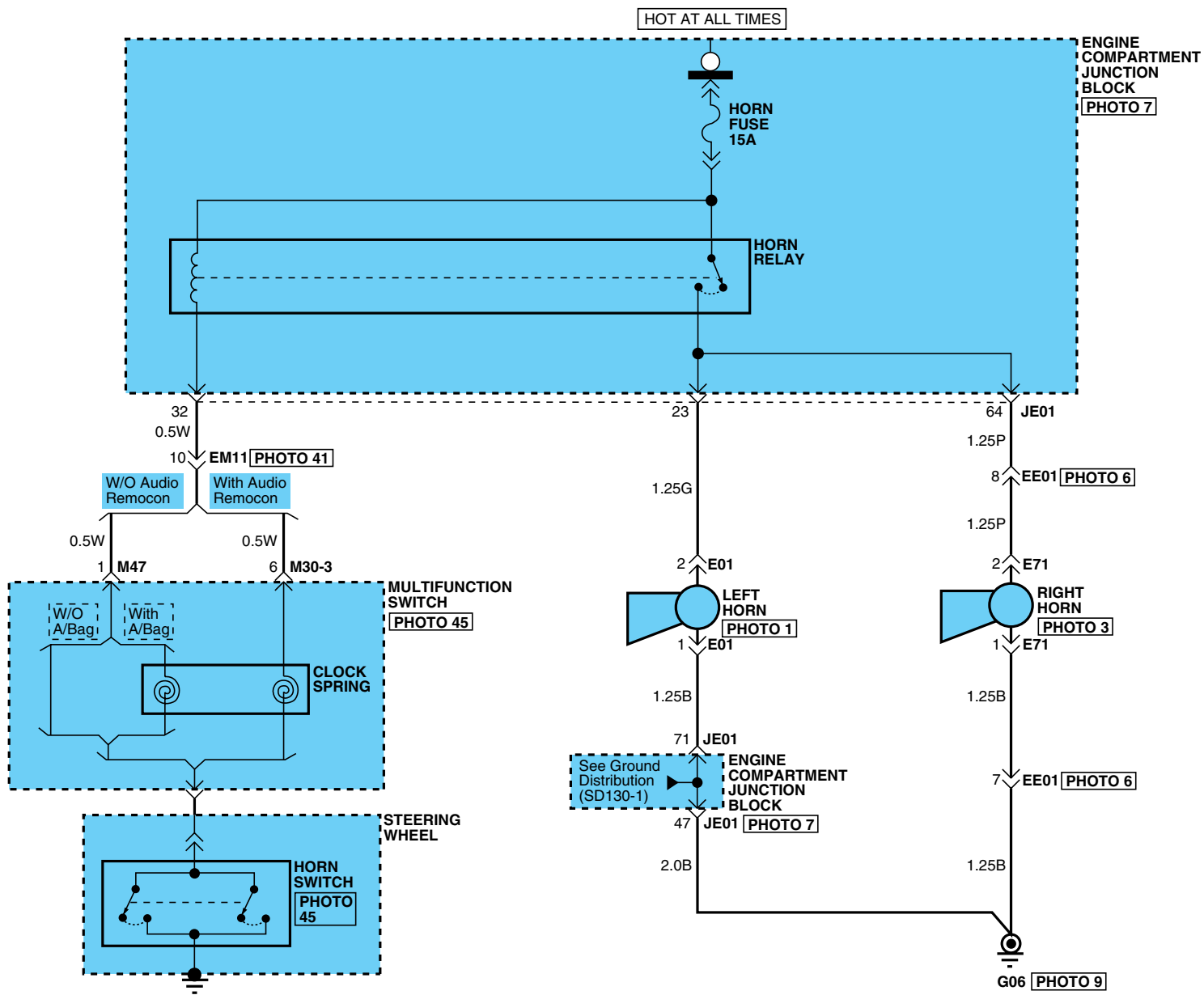

# HORNS

## HORNS (2)

SD968-2

E01

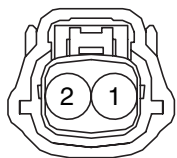

MLX\_HORN\_02F\_B\_FILT

E71

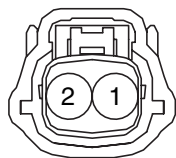

MLX\_HORN\_02F\_B\_FILT

M30-3

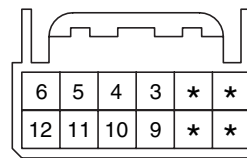

AMP\_025\_12F\_W

M47

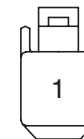

KET\_090II\_01F\_W

BLOWER & A/C CONTROLS (AUTO) (1)

SD971-1

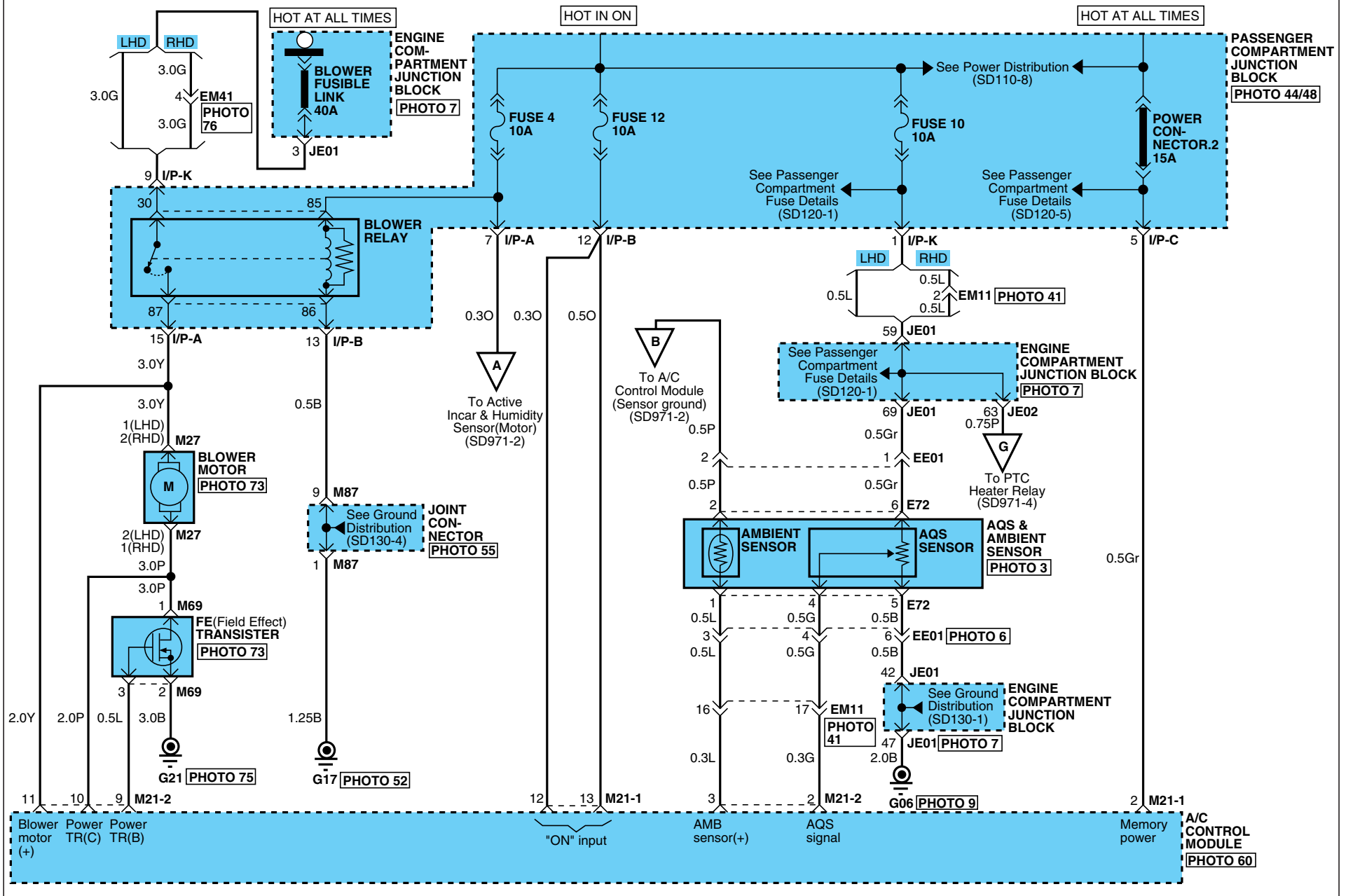

# BLOWER & A/C CONTROLS

## BLOWER & A/C CONTROLS (AUTO) (2)

SD971-2

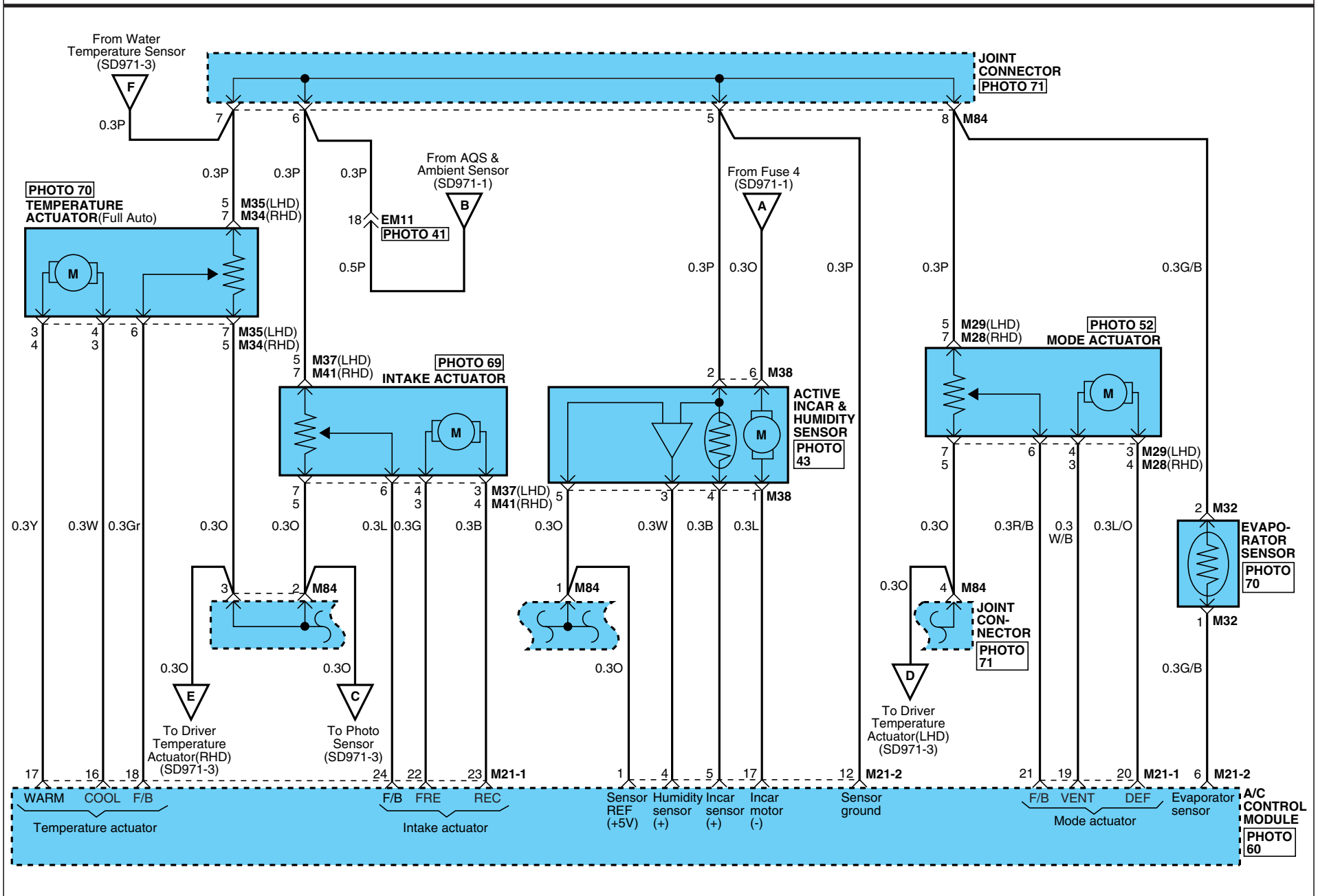

# BLOWER & A/C CONTROLS

## BLOWER & A/C CONTROLS (AUTO) (3)

SD971-3

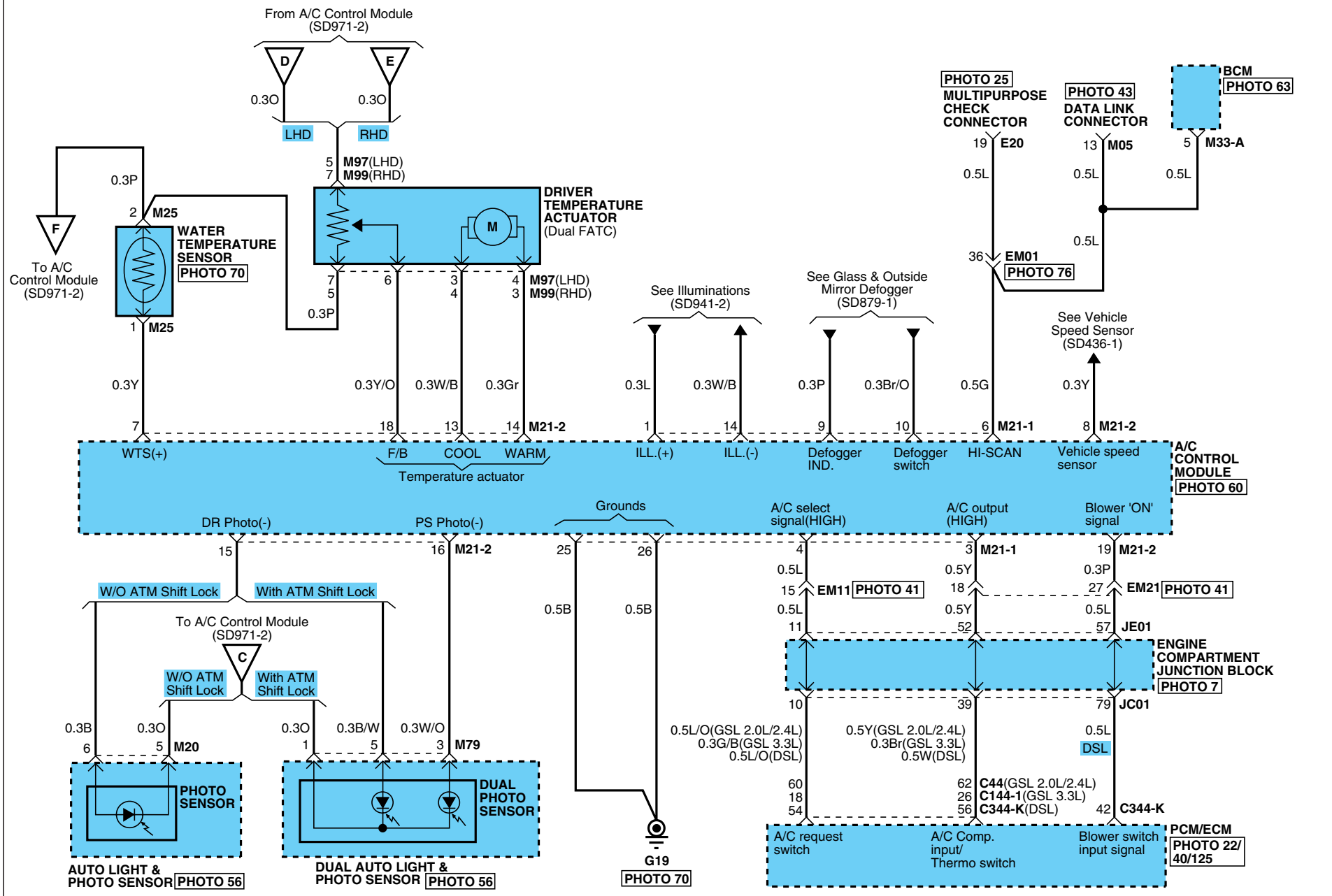

# BLOWER & A/C CONTROLS

## BLOWER & A/C CONTROLS (AUTO) (4)

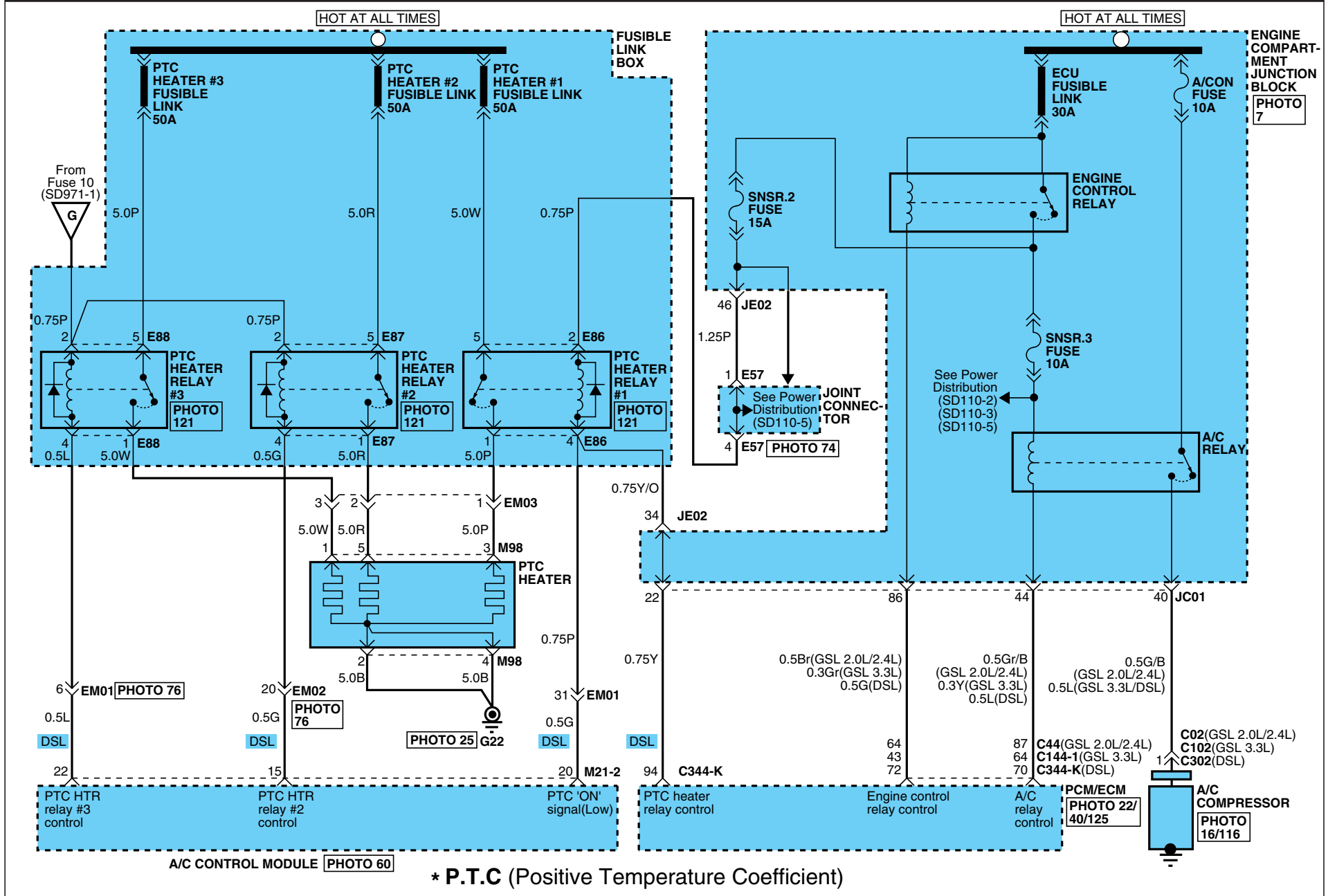

SD971-4



# BLOWER & A/C CONTROLS

## BLOWER & A/C CONTROLS (AUTO) (5)

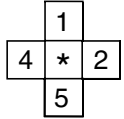
SD971-5

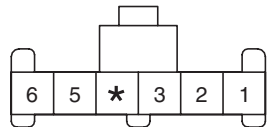
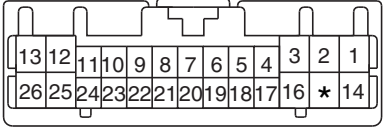
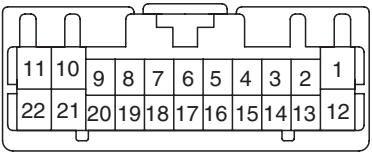
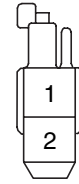
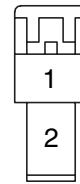
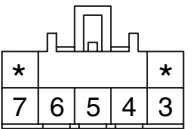
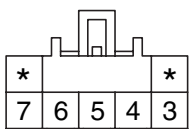
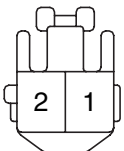
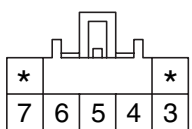
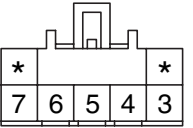
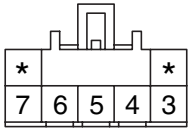
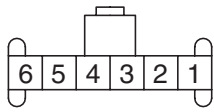
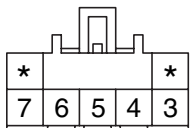
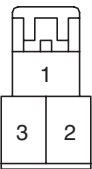
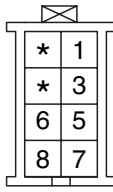
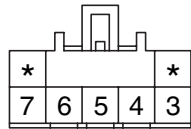
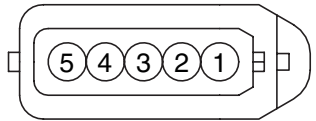
<p><b>C02/C102/C302</b></p>  <p>KUM_NMWP_01F_B</p>	<p><b>E86/E87/E88</b></p>  <p>CR05F019</p>	<p><b>E72</b></p>  <p>KET_090IWP_06F_B</p>	<p><b>M20</b></p>  <p>KET_91A_06F_W</p>
<p><b>M21-1</b></p>  <p>KET_0407_26F_W</p>	<p><b>M21-2</b></p>  <p>KET_0407_22F_W</p>	<p><b>M25</b></p>  <p>KET_090II_02F_W_SPK</p>	<p><b>M27</b></p>  <p>KUM_DSD_02F_W</p>
<p><b>M28</b></p>  <p>KUM_CDR_07F_L</p>	<p><b>M29</b></p>  <p>KUM_CDR_07F_L</p>	<p><b>M32</b></p>  <p>KET_090II_02F_W_L</p>	<p><b>M34</b></p>  <p>KUM_CDR_07F_W</p>
<p><b>M35</b></p>  <p>KUM_CDR_07F_W</p>	<p><b>M37</b></p>  <p>KUM_CDR_07F_L</p>	<p><b>M38</b></p>  <p>AKET_91A_06F_W</p>	<p><b>M41</b></p>  <p>KUM_CDR_07F_W</p>
<p><b>M69</b></p>  <p>KUM_DSD_03F_B</p>	<p><b>M79</b></p>  <p>KET_030_08F_GR</p>	<p><b>M97/M99</b></p>  <p>KUM_CDR_07F_W</p>	<p><b>M98</b></p>  <p>AMP_375_05F_B</p>



**BLOWER & A/C CONTROLS**

**BLOWER & A/C CONTROLS (AUTO) (6)**

**SD971-6**

**MEMO**

BLOWER & A/C CONTROLS (MANUAL) (1)

SD971-7

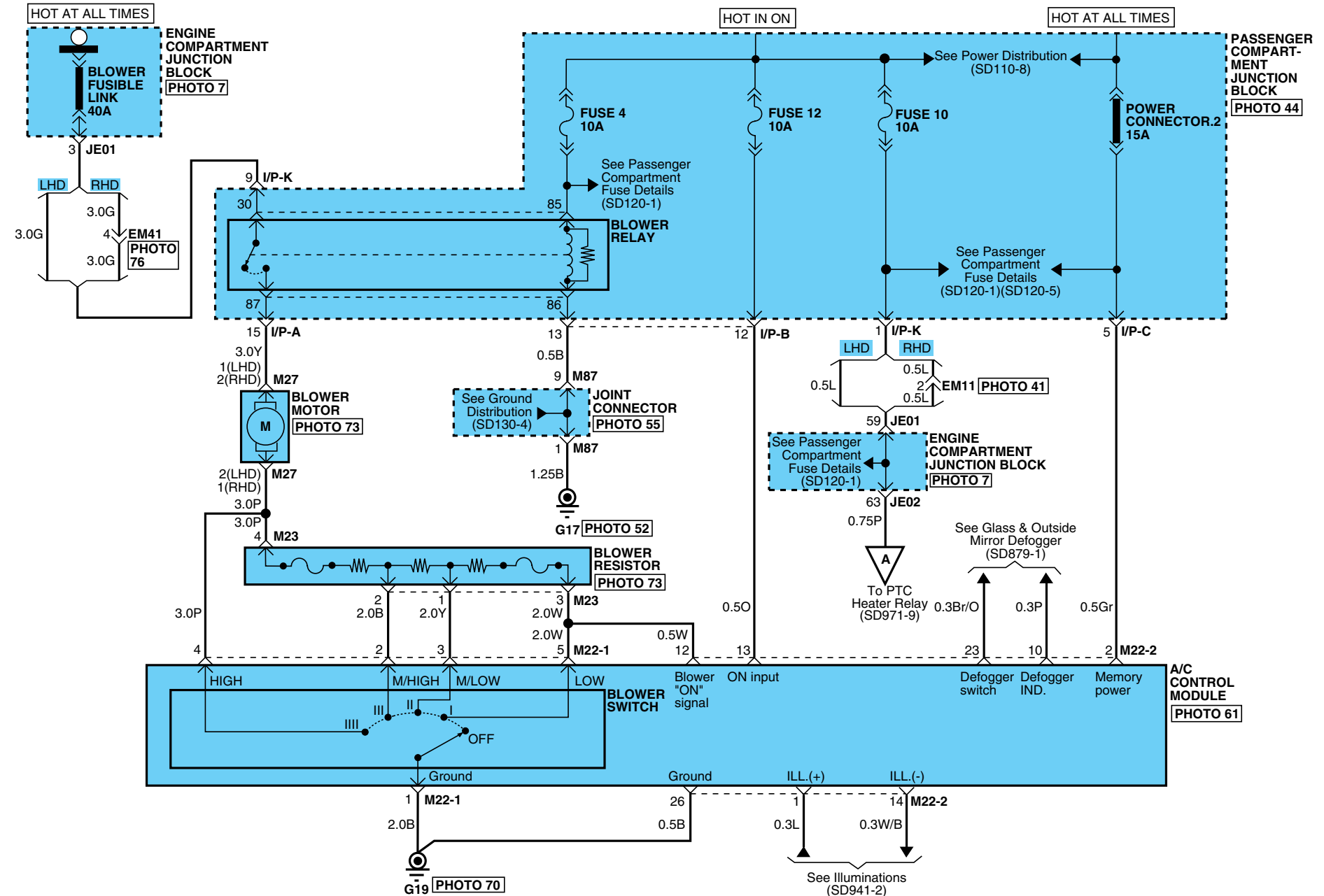

# BLOWER & A/C CONTROLS

## BLOWER & A/C CONTROLS (MANUAL) (2)

SD971-8

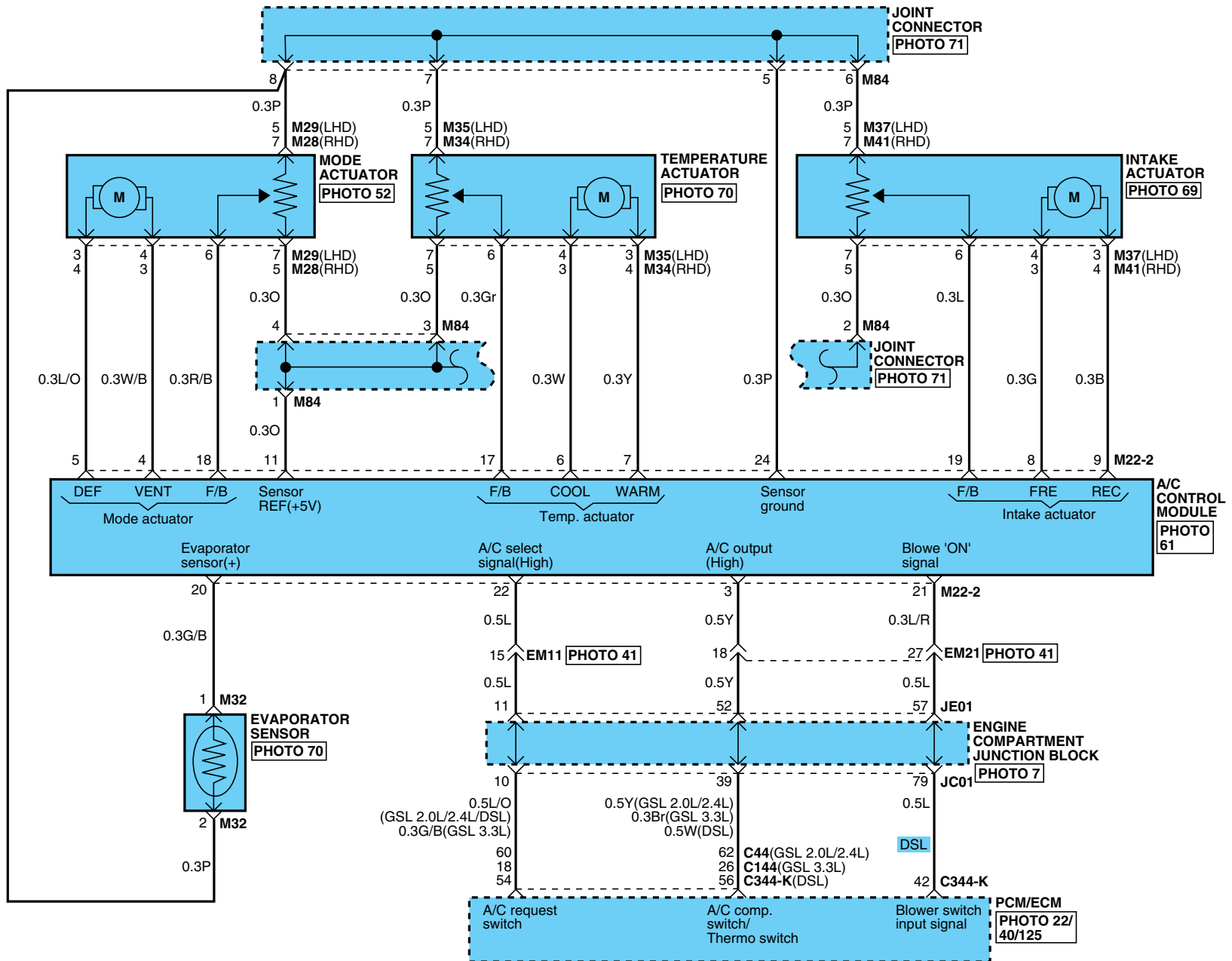

# BLOWER & A/C CONTROLS

## BLOWER & A/C CONTROLS (MANUAL) (3)

SD971-9

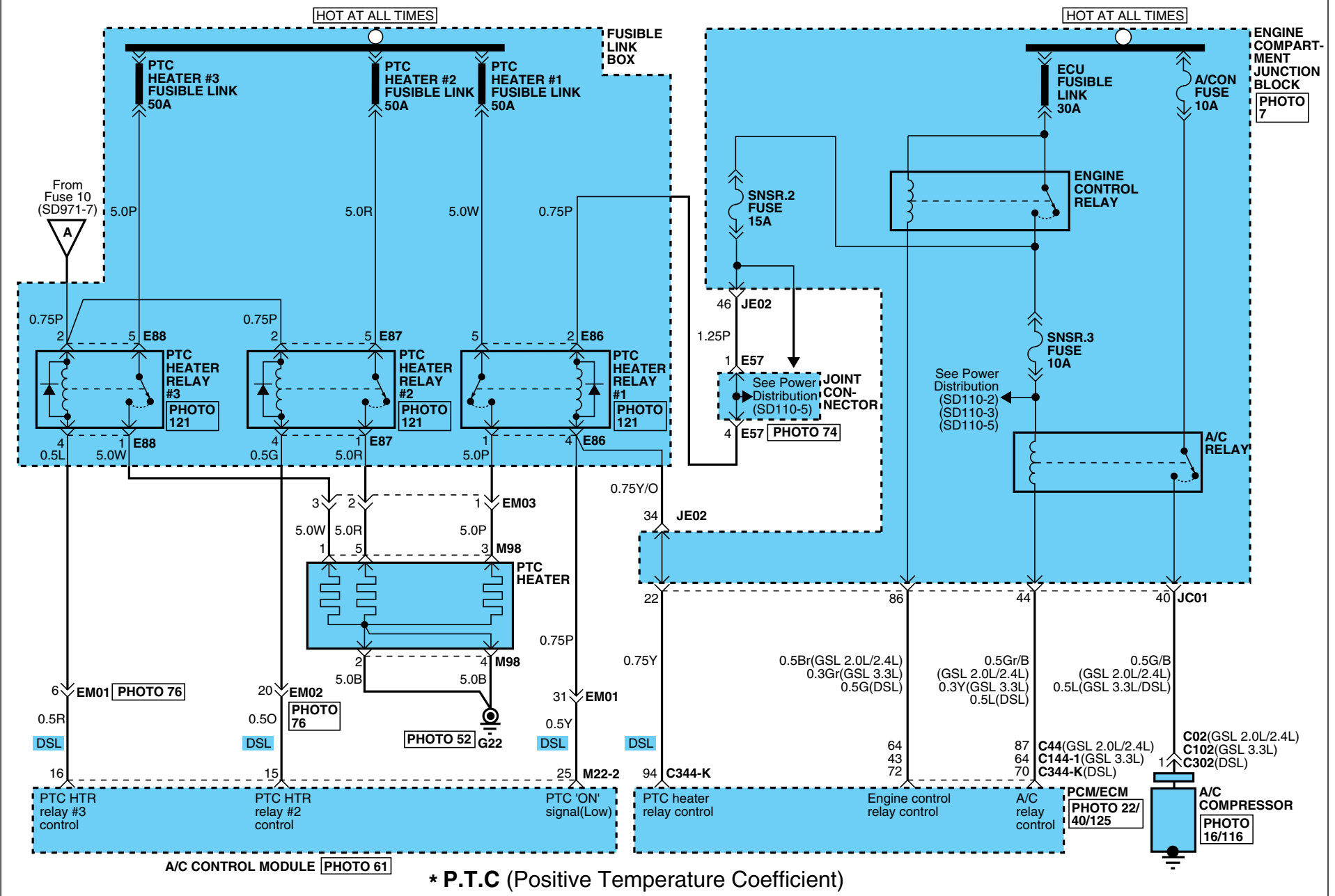





\* P.T.C (Positive Temperature Coefficient)

# BLOWER & A/C CONTROLS

## BLOWER & A/C CONTROLS (MANUAL) (4)

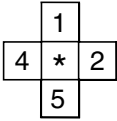
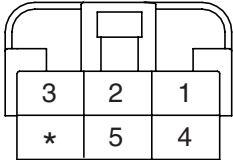
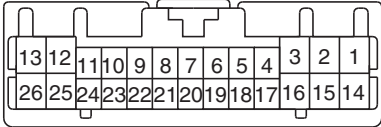
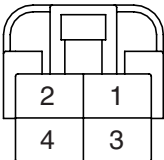
SD971-10

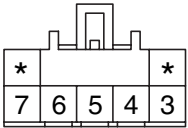
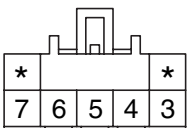
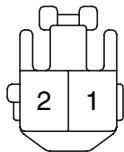
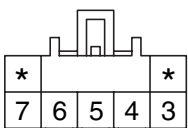
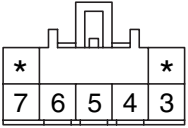
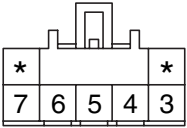
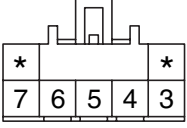
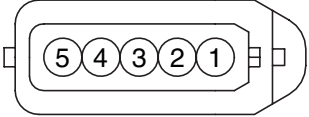
<p><b>C02</b></p>  <p>KUM_NMWP_01F_B</p>	<p><b>C102</b></p>  <p>KUM_NMWP_01F_B</p>	<p><b>C302</b></p>  <p>KUM_NMWP_01F_B</p>	<p><b>E86/E87/E88</b></p>  <p>CR05F019</p>
<p><b>M22-1</b></p>  <p>KET_250DL_06F_W</p>	<p><b>M22-2</b></p>  <p>KET_0407_26F_W</p>	<p><b>M23</b></p>  <p>KET_250DL_04F_W</p>	<p><b>M27</b></p>  <p>KUM_DSD_02F_W</p>
<p><b>M28</b></p>  <p>KUM_CDR_07F_L</p>	<p><b>M29</b></p>  <p>KUM_CDR_07F_L</p>	<p><b>M32</b></p>  <p>KET_090II_02F_W_L</p>	<p><b>M34</b></p>  <p>KUM_CDR_07F_W</p>
<p><b>M35</b></p>  <p>KUM_CDR_07F_W</p>	<p><b>M37</b></p>  <p>KUM_CDR_07F_L</p>	<p><b>M41</b></p>  <p>KUM_CDR_07F_L</p>	<p><b>M98</b></p>  <p>AMP_375_05F_B</p>

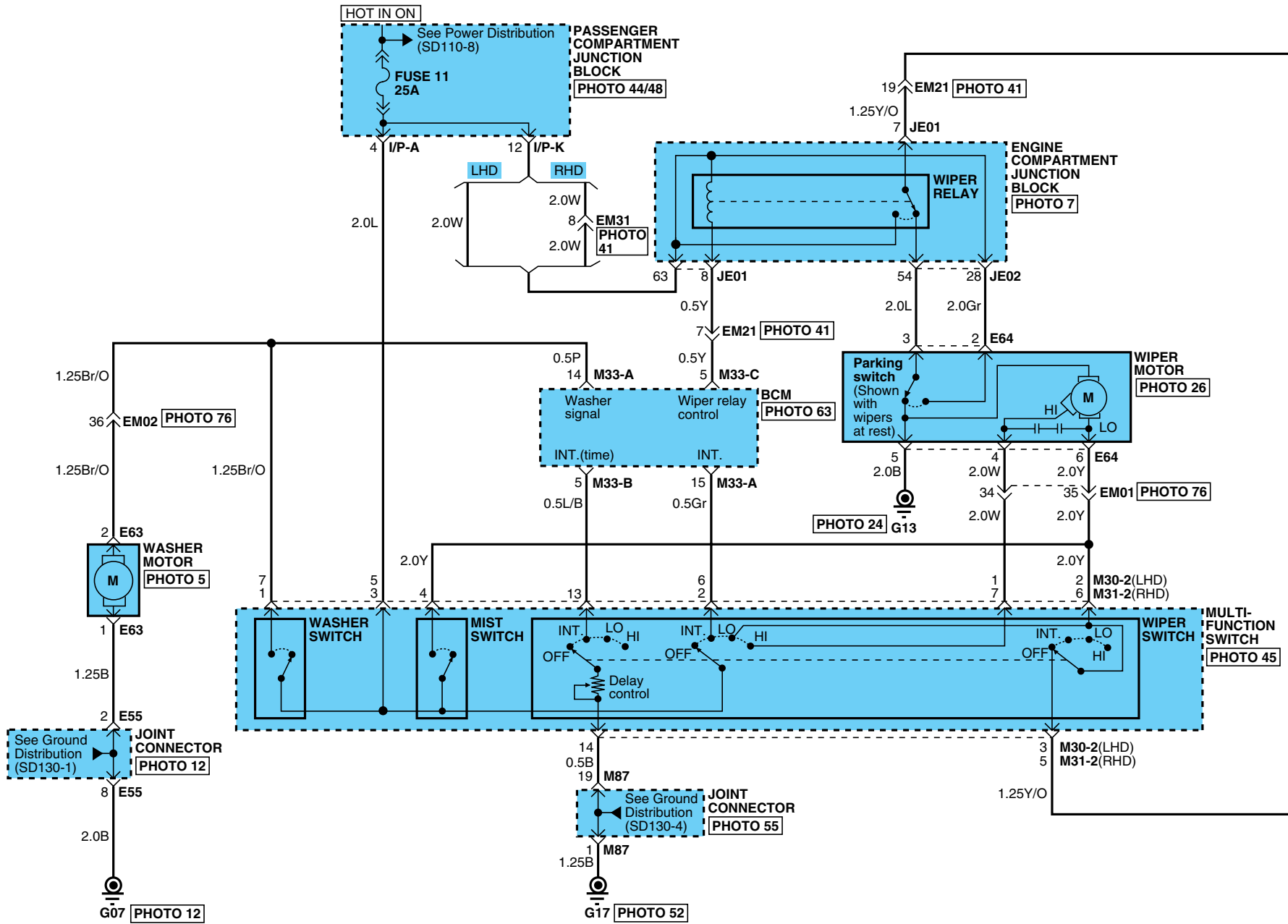

# WIPER & WASHER

## WIPER & WASHER (2)

SD981-2

**E63**

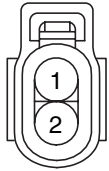

KET\_090WP\_02F\_B\_SIDE

**E64**

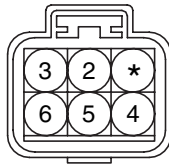

KUM\_NMWP\_06F\_B

**M30-2**

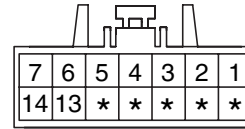

KET\_090II\_14F\_W\_SW

**M31-2**

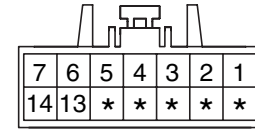

KET\_090II\_14F\_W\_SW

**M33-A**

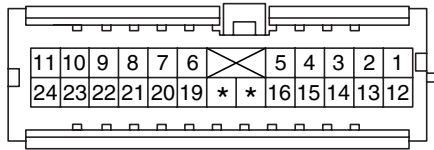

AMP\_040III\_24F\_W

**M33-B**

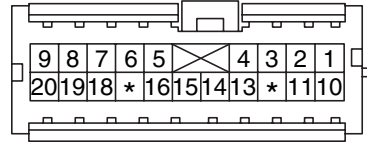

AMP\_040III\_20F\_W

**M33-C**

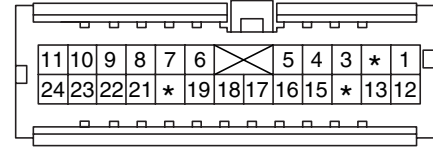

AMP\_040III\_24F\_GR

**BLANK**

COMPONENT LOCATIONS (1)

CL-1

PHOTO.1

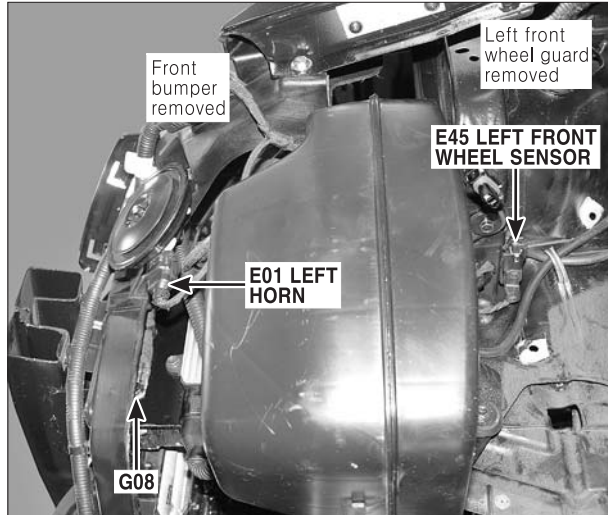

PHOTO.2

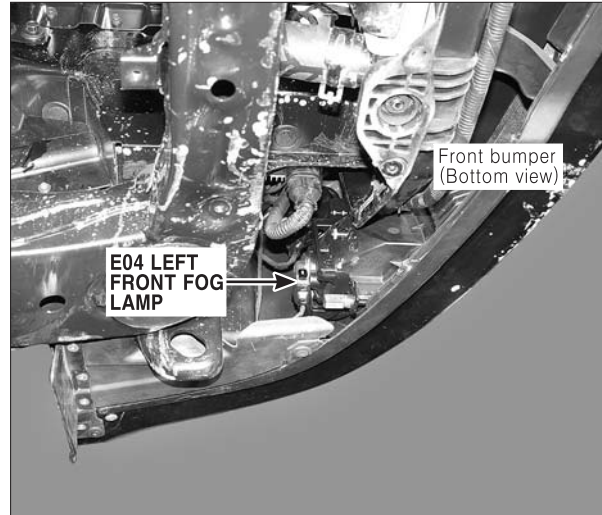

PHOTO.3

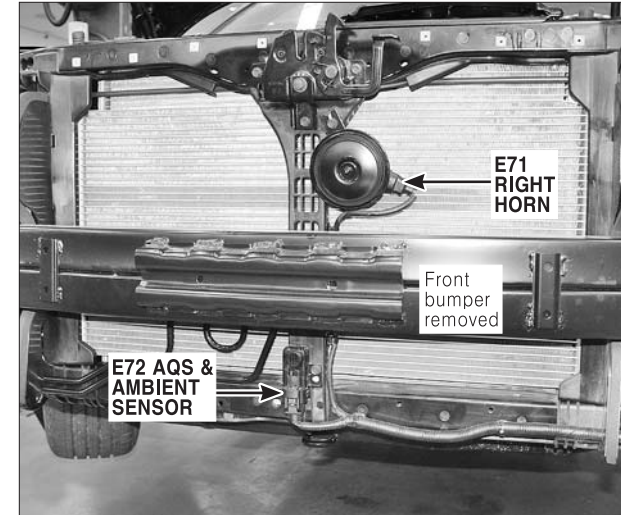

PHOTO.4

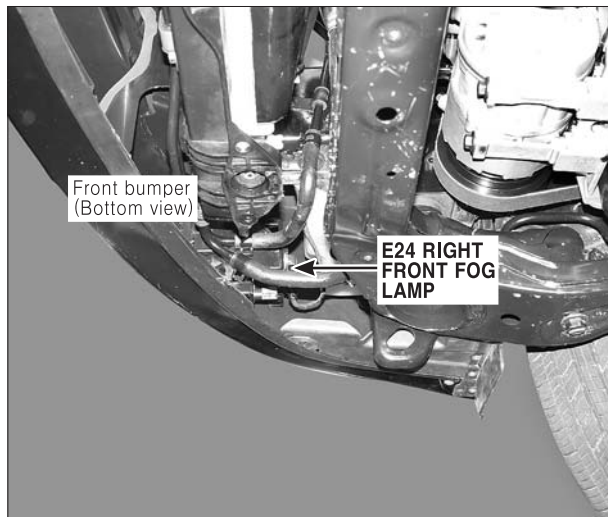

PHOTO.5

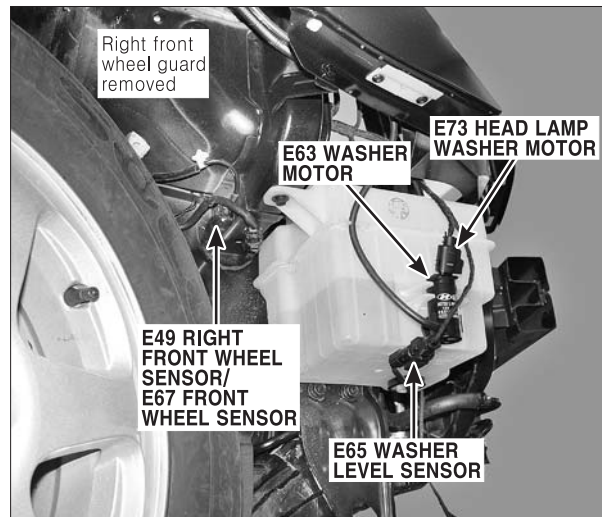
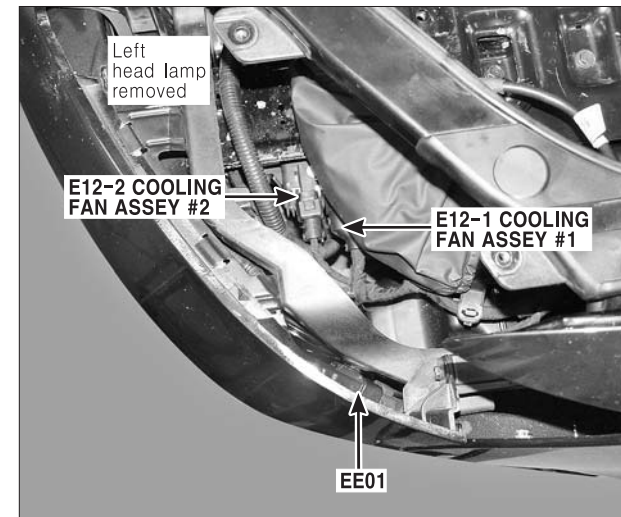

PHOTO.6





# COMPONENT LOCATIONS

## COMPONENT LOCATIONS (2)

CL-2

PHOTO.7

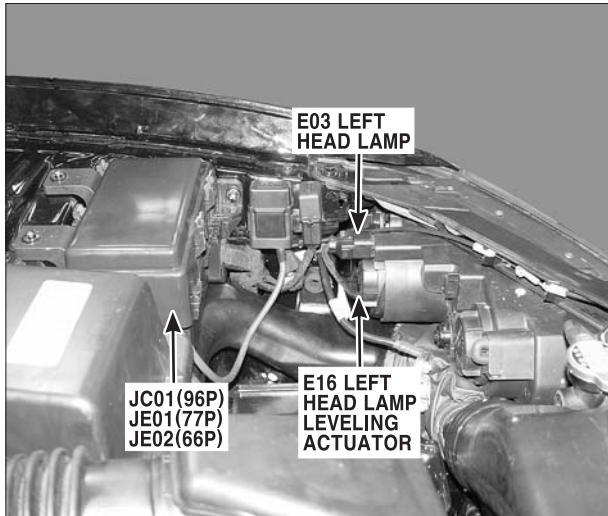

PHOTO.8

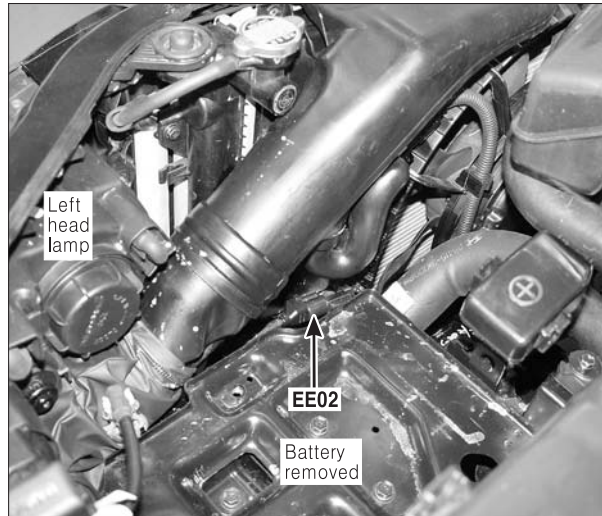

PHOTO.9

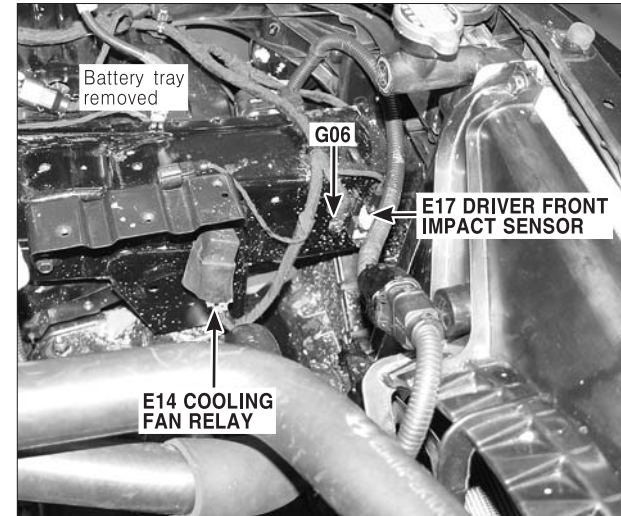

PHOTO.10

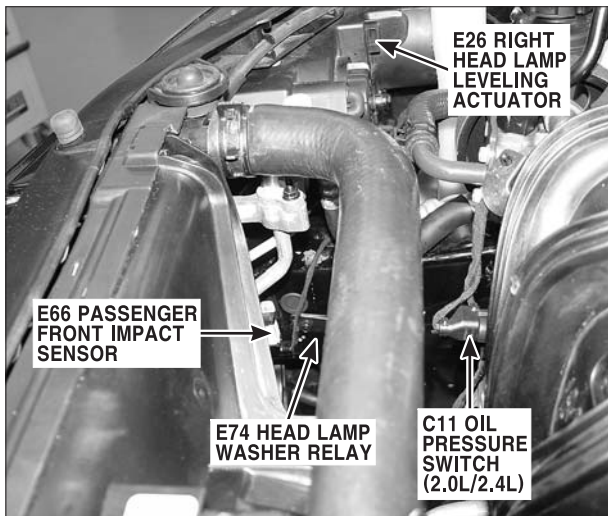
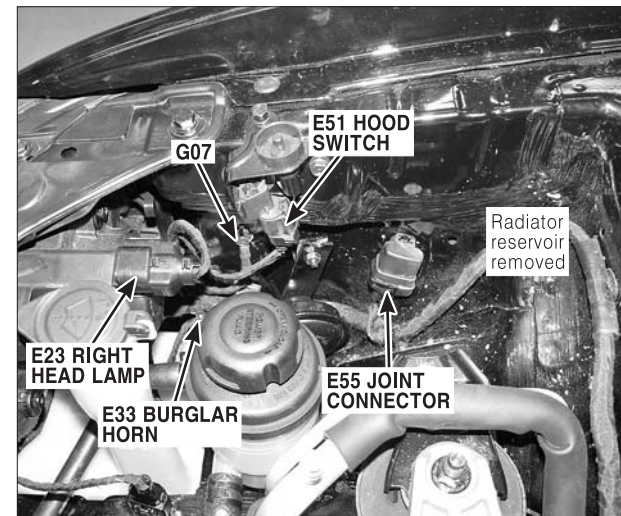

PHOTO.11



PHOTO.12



# COMPONENT LOCATIONS

## COMPONENT LOCATIONS (3)

CL-3

PHOTO.13

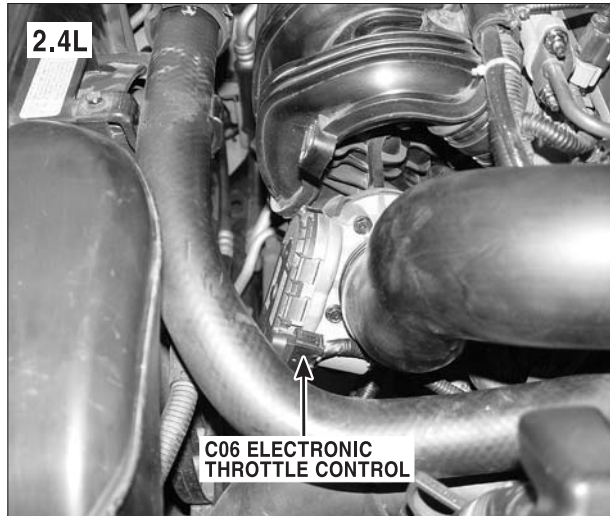

PHOTO.14

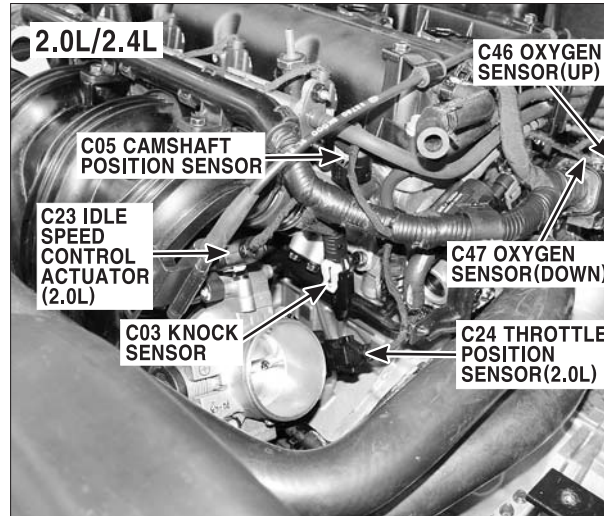

PHOTO.15

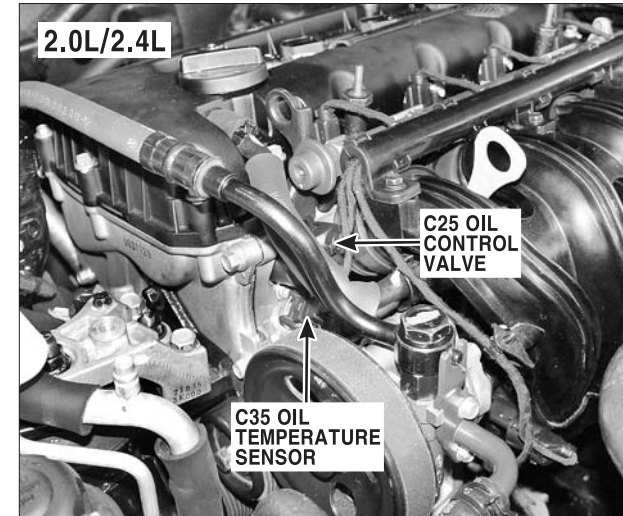

PHOTO.16

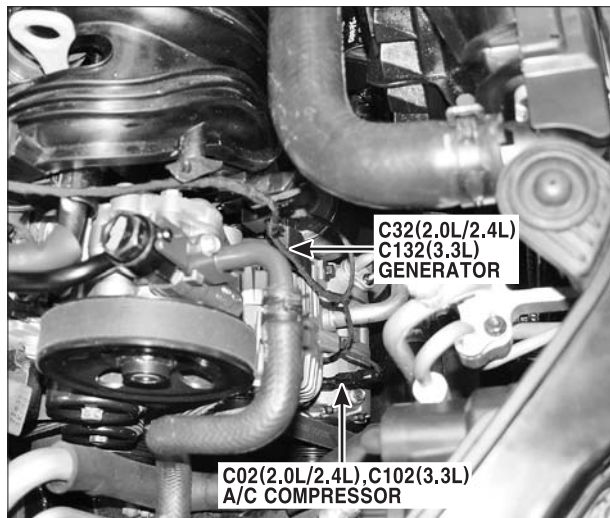

PHOTO.17

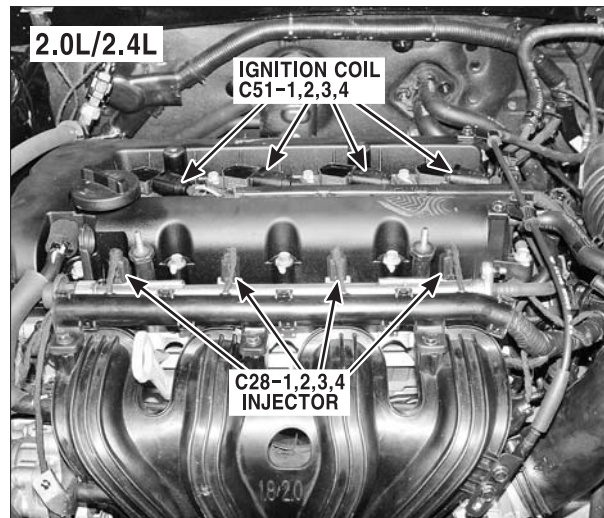
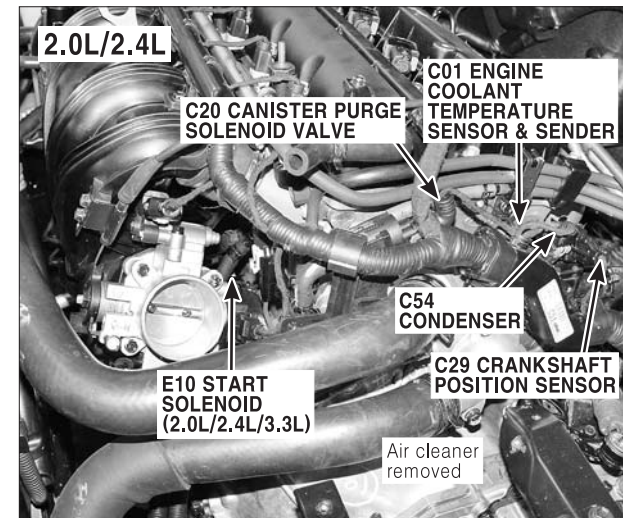

PHOTO.18



# COMPONENT LOCATIONS

## COMPONENT LOCATIONS (4)

CL-4

PHOTO.19

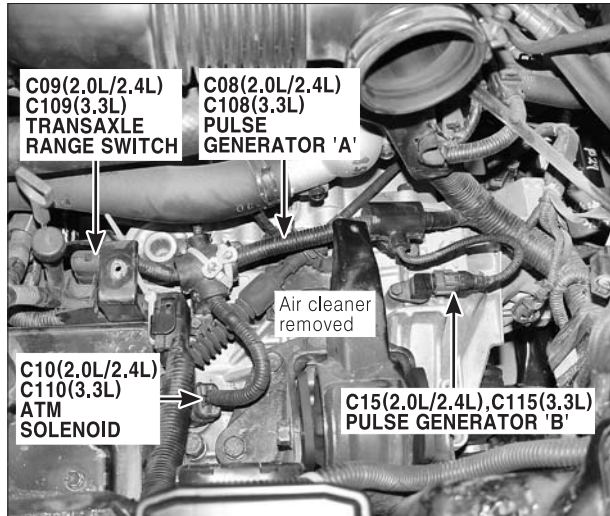

PHOTO.20

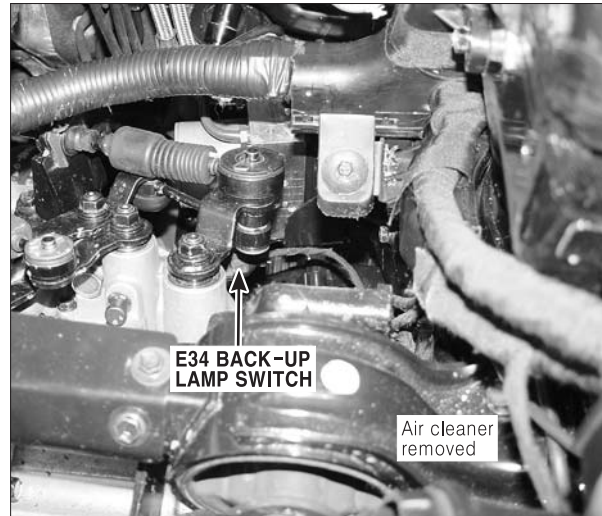

PHOTO.21

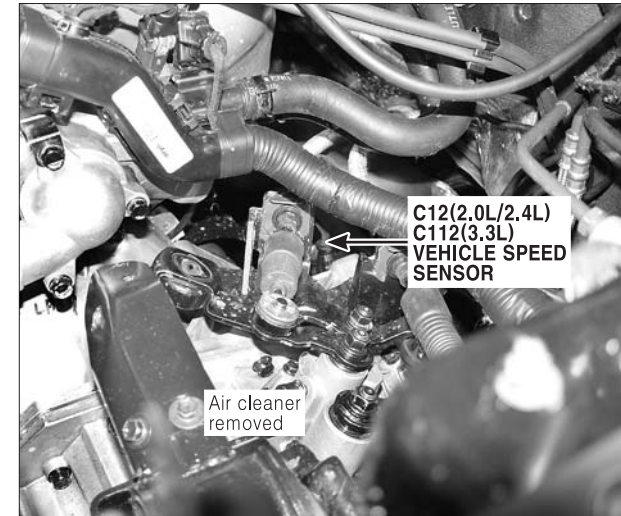

PHOTO.22

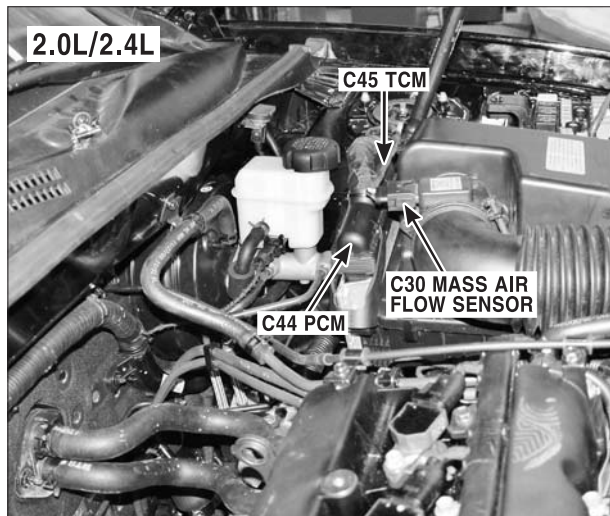

PHOTO.23

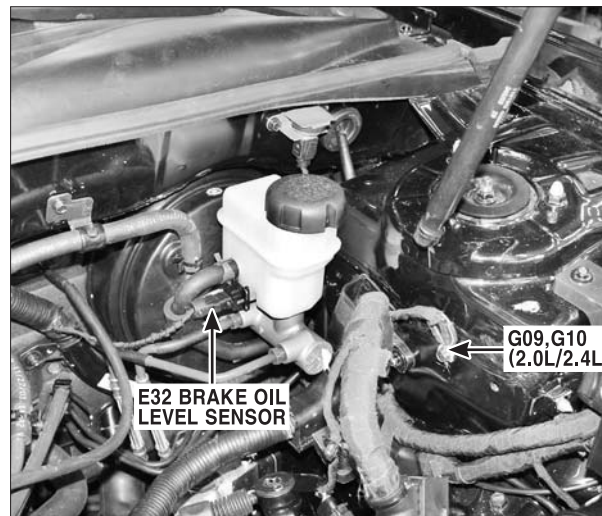

PHOTO.24



# COMPONENT LOCATIONS

## COMPONENT LOCATIONS (5)

CL-5

PHOTO.25

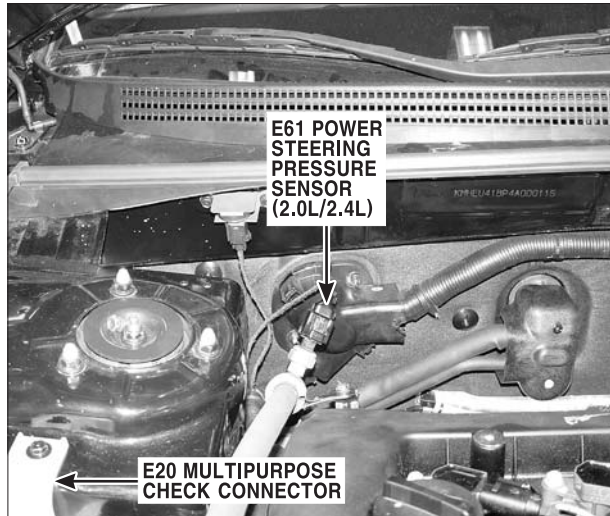

PHOTO.26



PHOTO.27

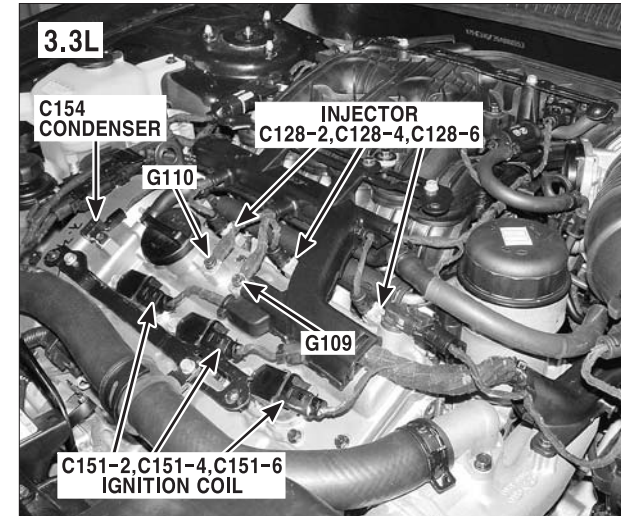

PHOTO.28

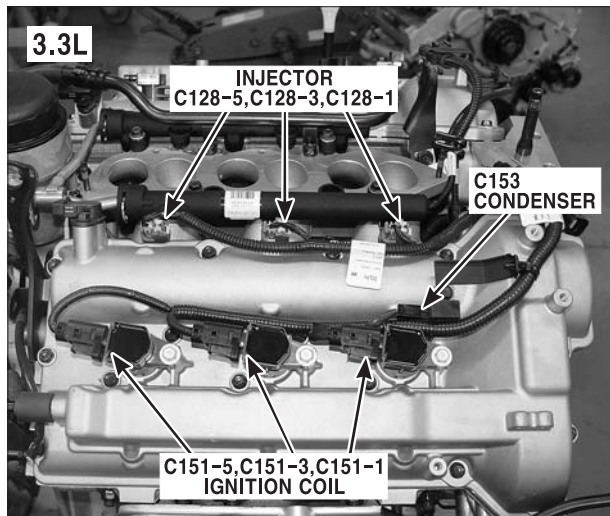

PHOTO.29

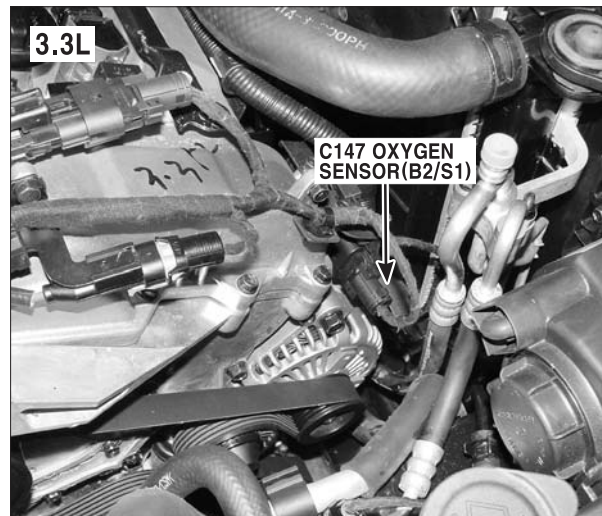
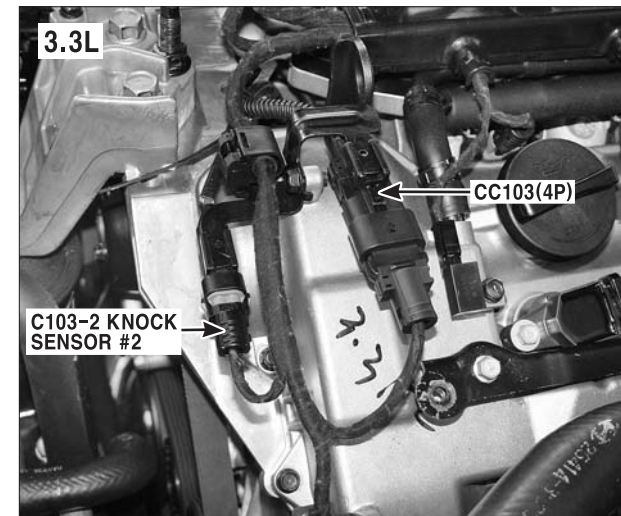

PHOTO.30



# COMPONENT LOCATIONS

## COMPONENT LOCATIONS (6)

CL-6

PHOTO.31

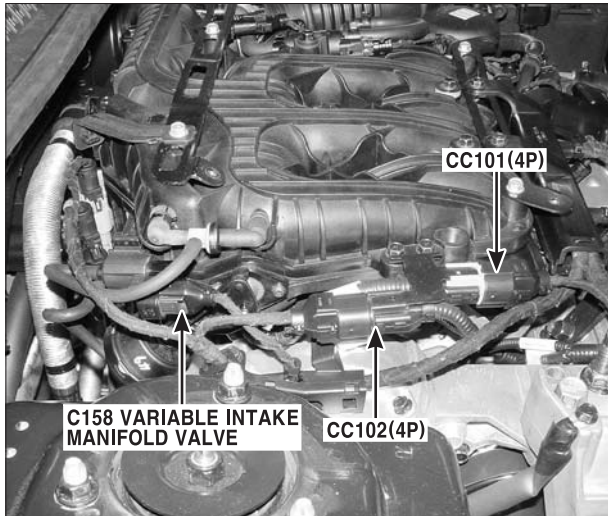

PHOTO.32

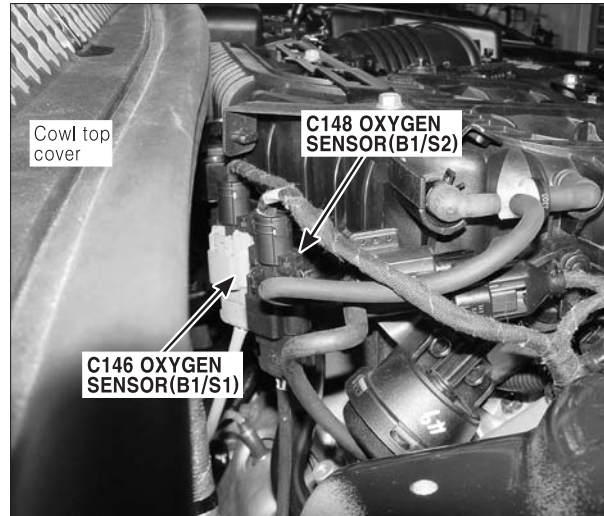

PHOTO.33

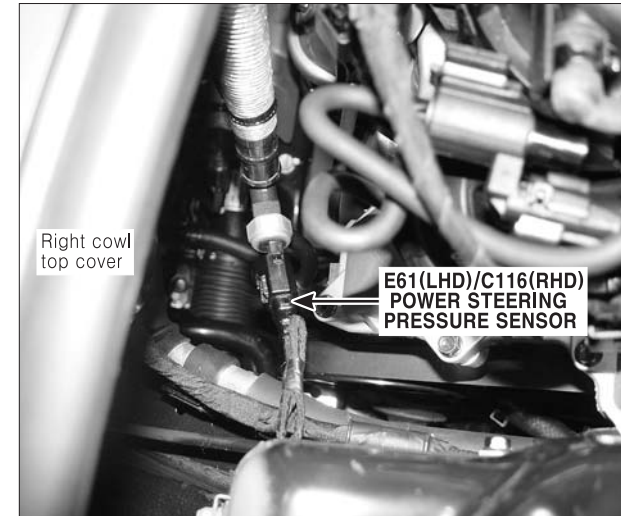

PHOTO.34

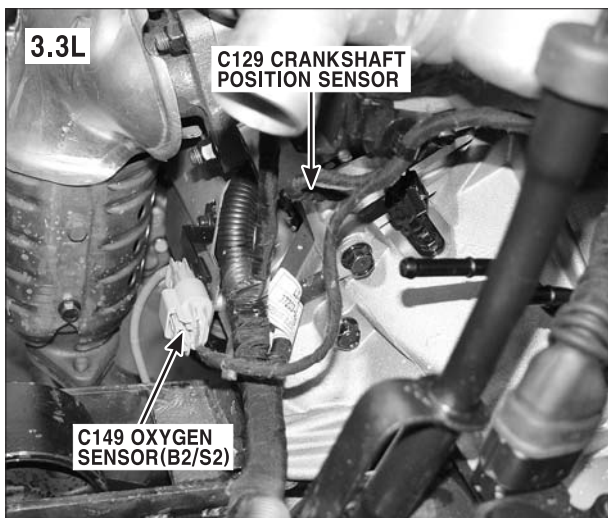

PHOTO.35

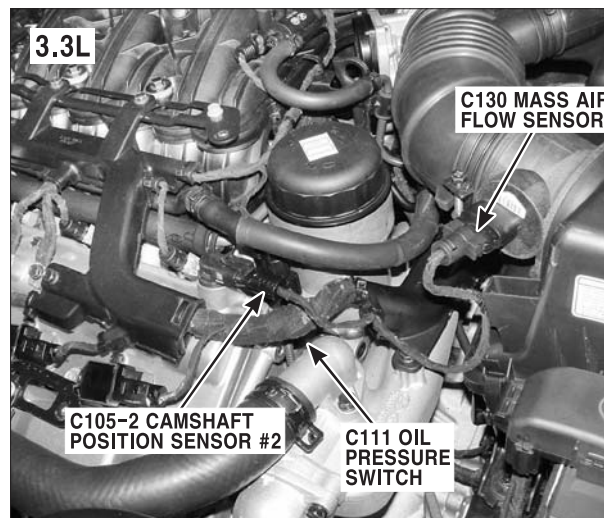
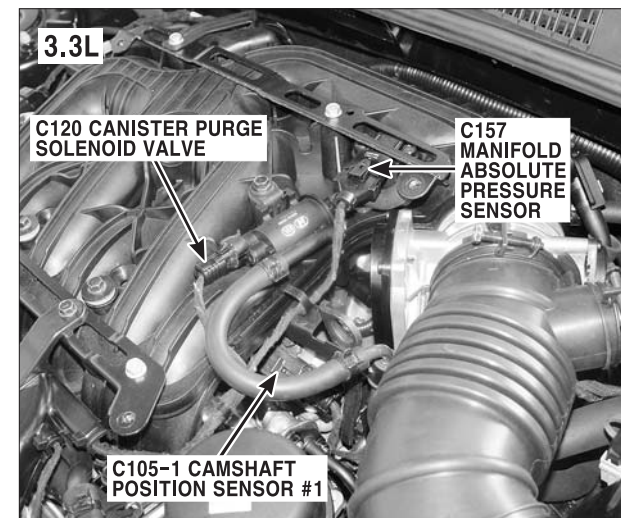

PHOTO.36



**COMPONENT LOCATIONS**

**COMPONENT LOCATIONS (7)**

**CL-7**

**PHOTO.37**

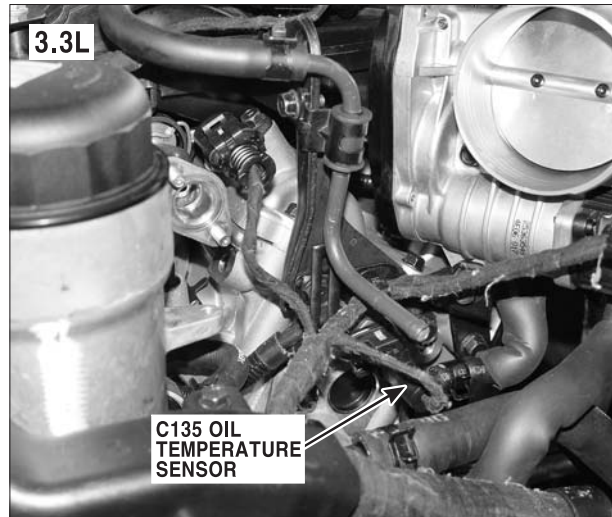

**PHOTO.38**

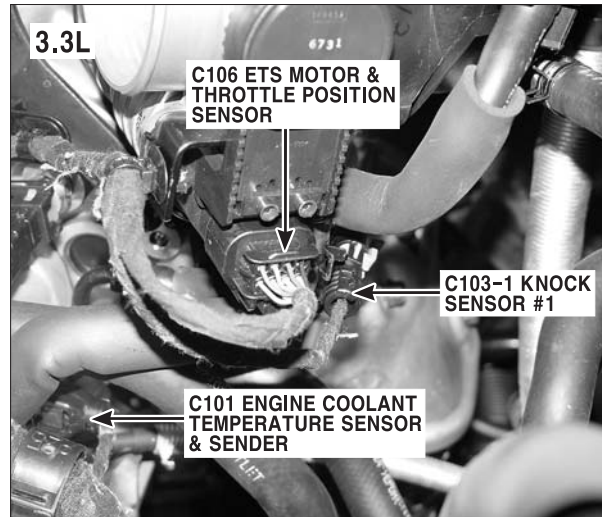

**PHOTO.39**

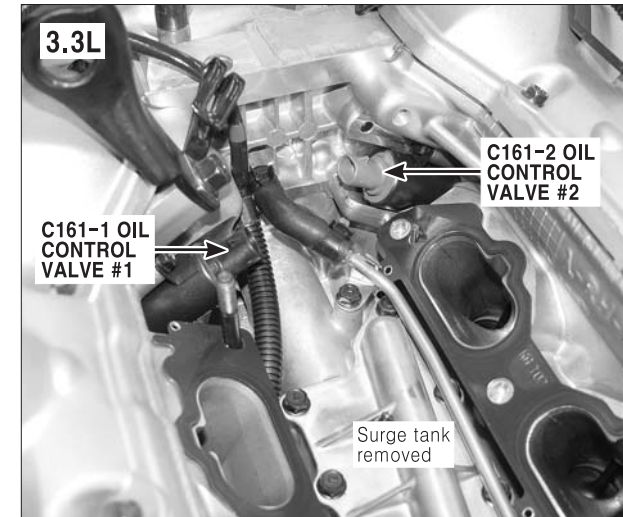

**PHOTO.40**

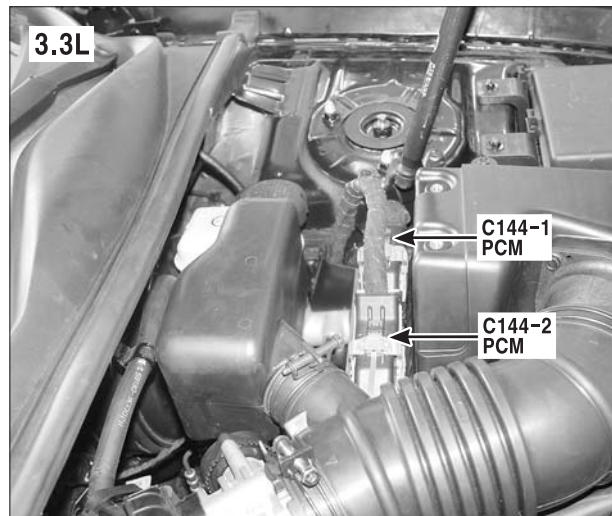

**PHOTO.41**

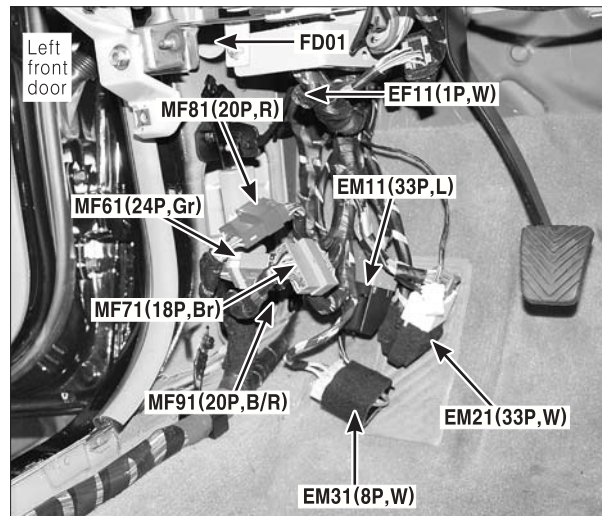

**PHOTO.42**

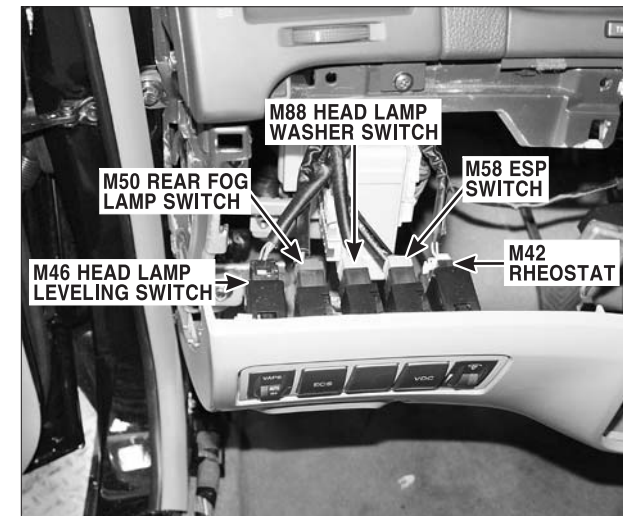

# COMPONENT LOCATIONS

## COMPONENT LOCATIONS (8)

CL-8

PHOTO.43

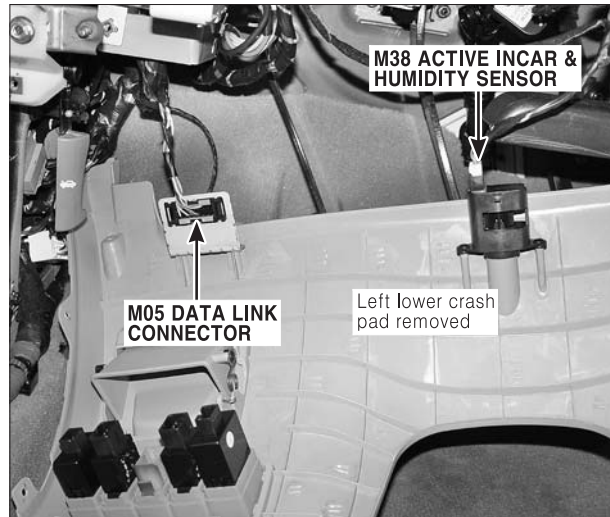

PHOTO.44

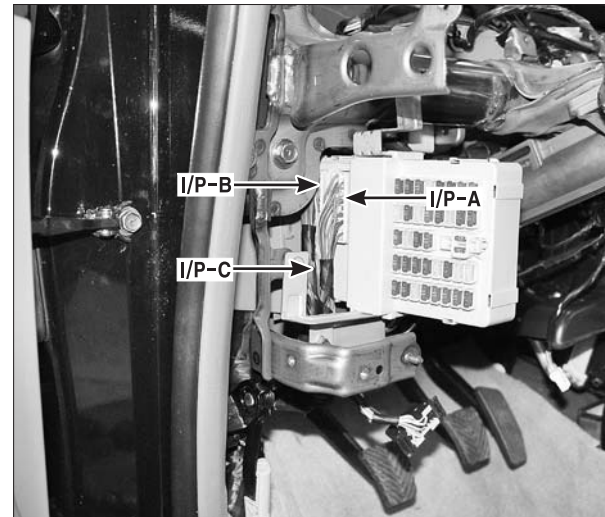

PHOTO.45

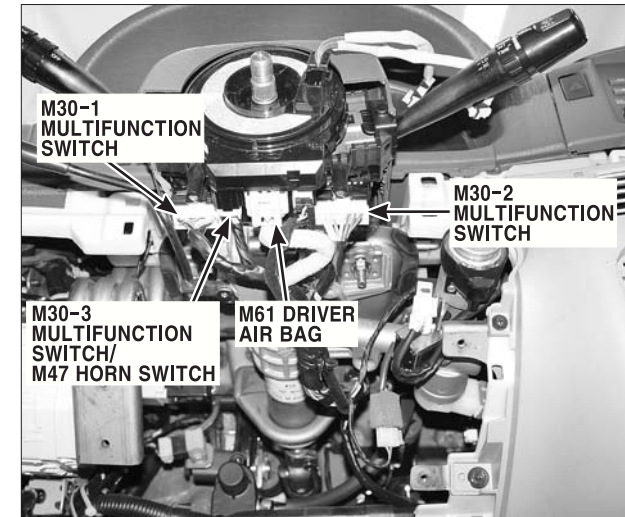

PHOTO.46

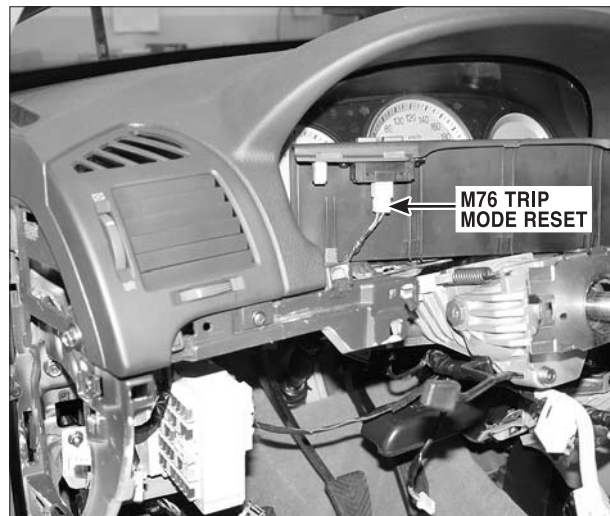
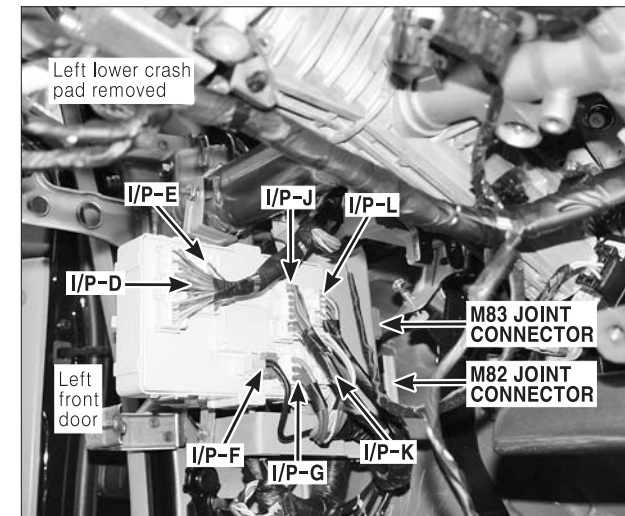

PHOTO.47



PHOTO.48



**COMPONENT LOCATIONS**

**COMPONENT LOCATIONS (9)**

**CL-9**

**PHOTO.49**

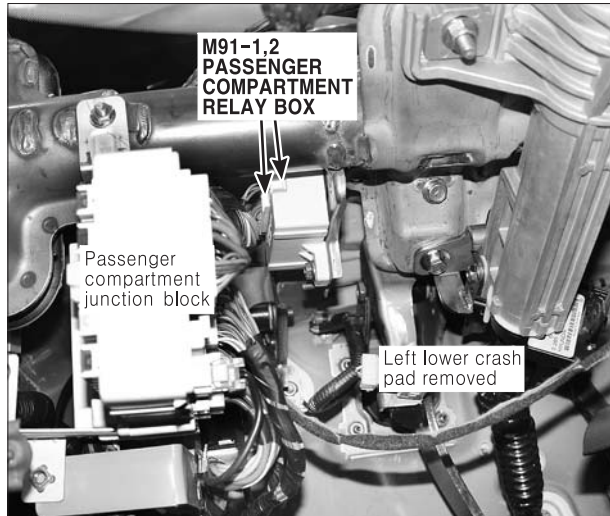

**PHOTO.50**

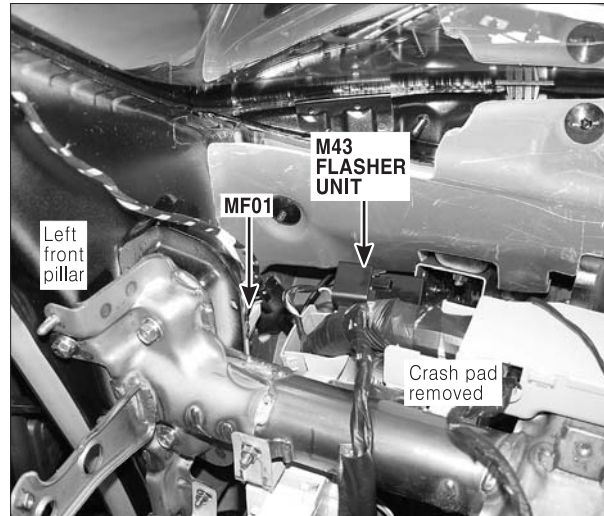

**PHOTO.51**

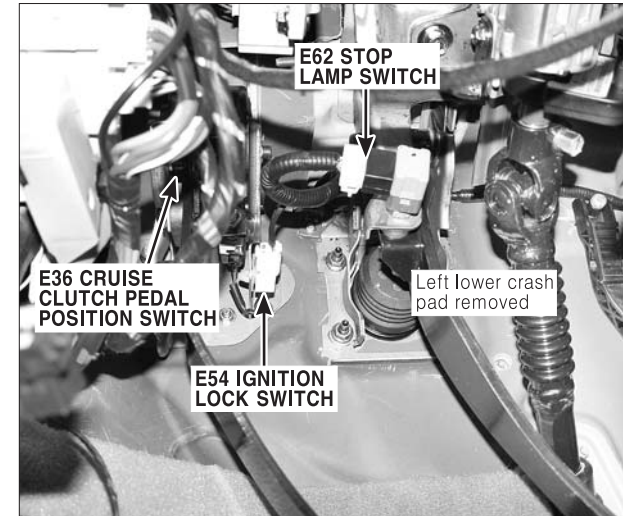

**PHOTO.52**

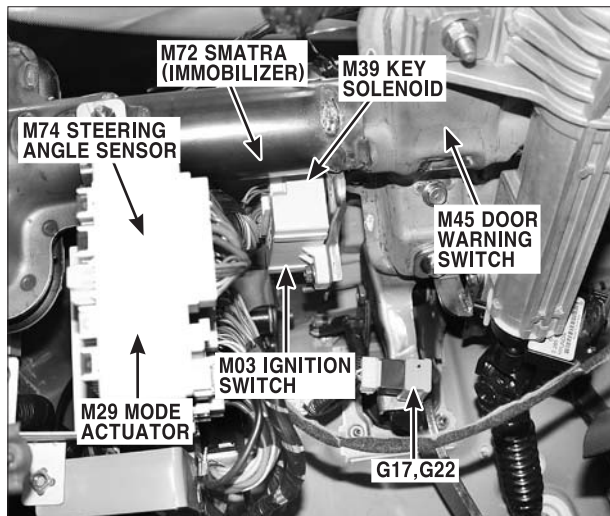

**PHOTO.53**

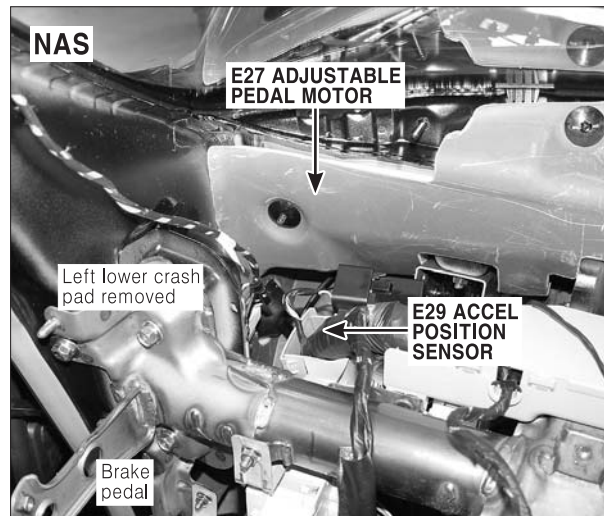

**PHOTO.54**

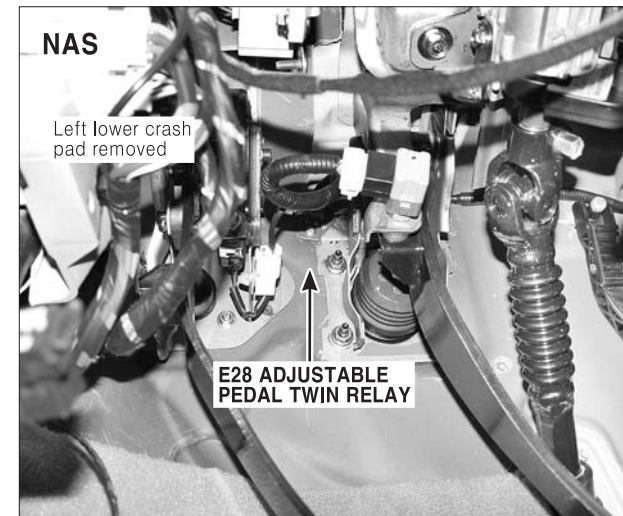



# COMPONENT LOCATIONS

## COMPONENT LOCATIONS (10)

CL-10

PHOTO.55

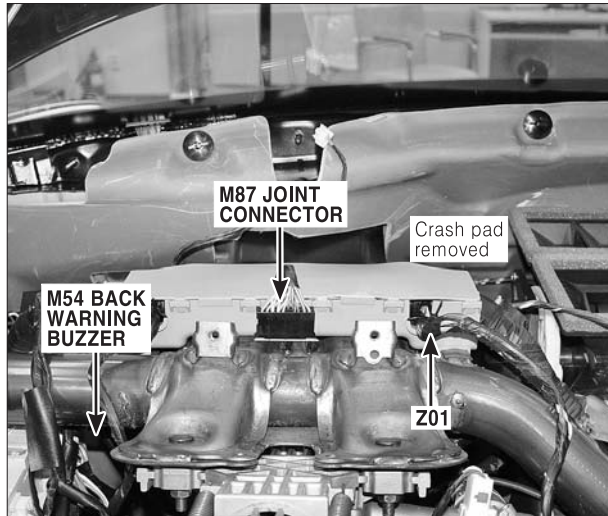

PHOTO.56

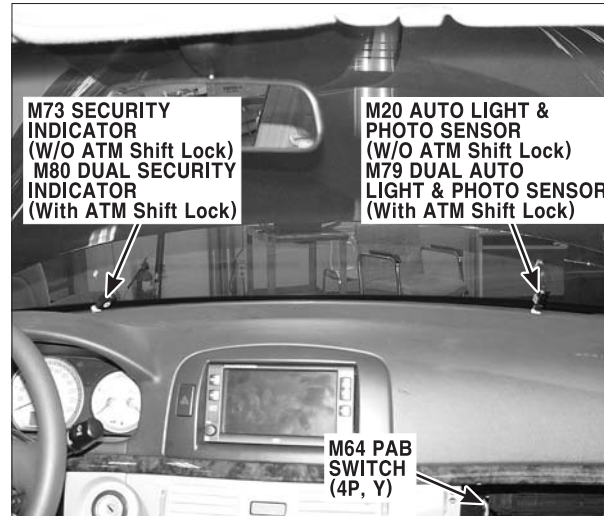

PHOTO.57



PHOTO.58

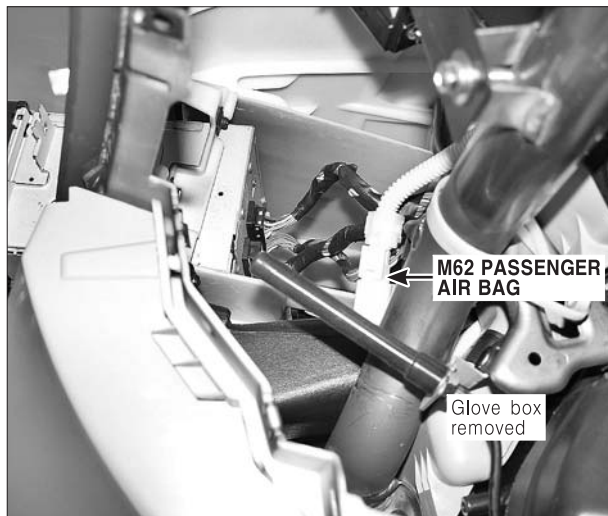

PHOTO.59

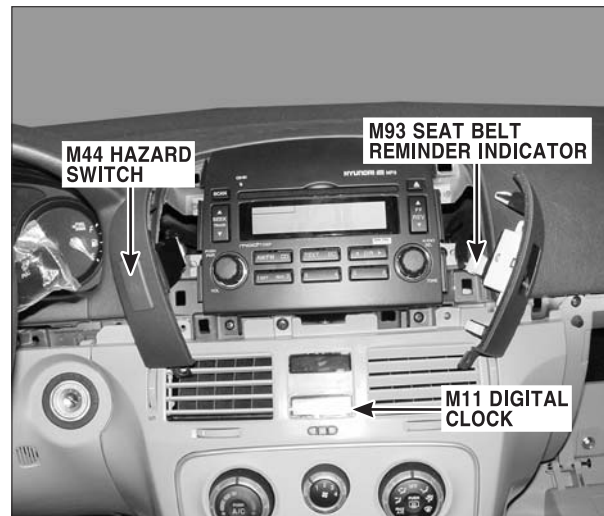
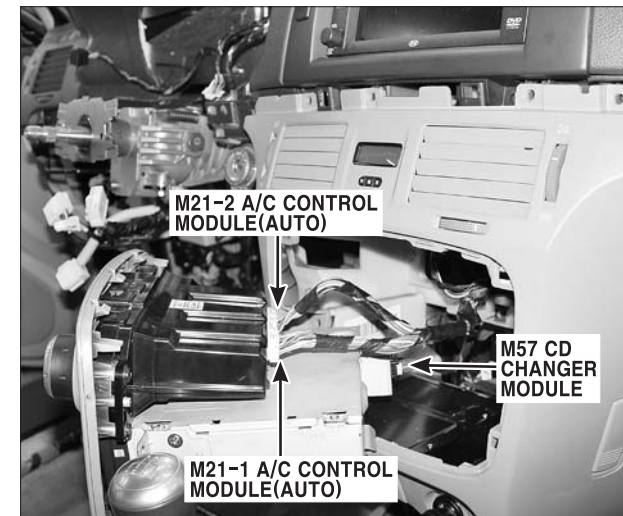

PHOTO.60



# COMPONENT LOCATIONS

## COMPONENT LOCATIONS (11)

CL-11

PHOTO.61

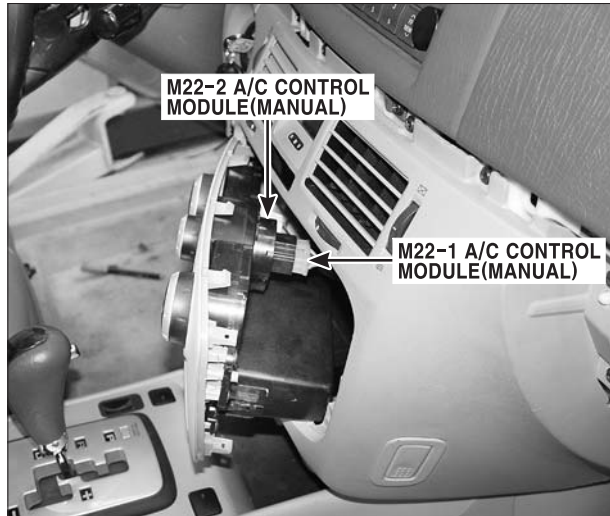

PHOTO.62

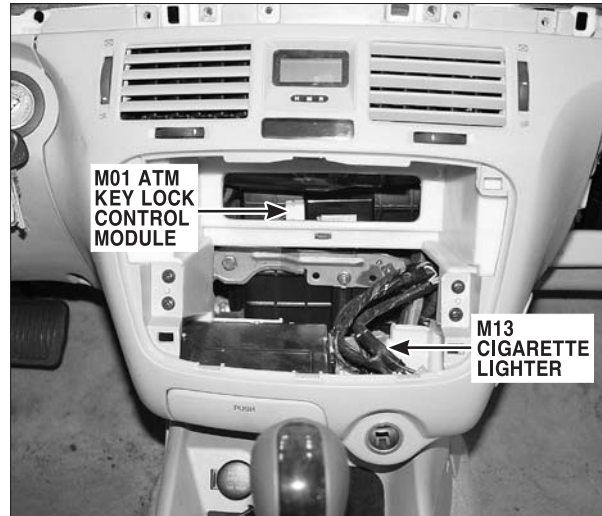

PHOTO.63

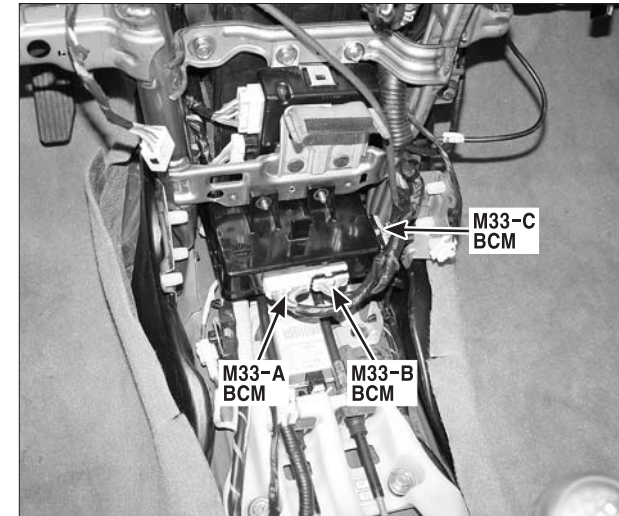

PHOTO.64

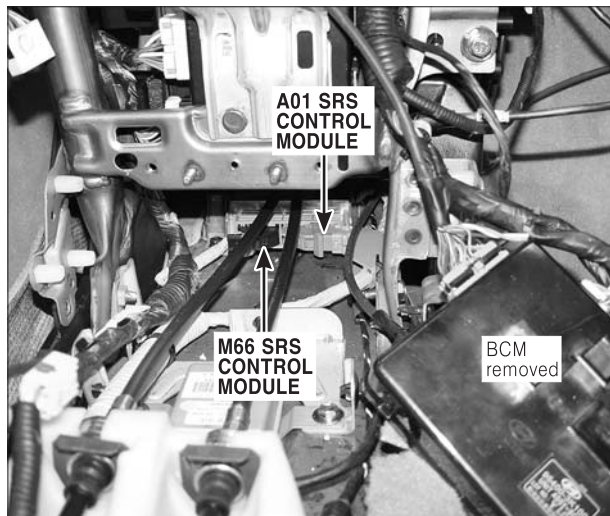

PHOTO.65

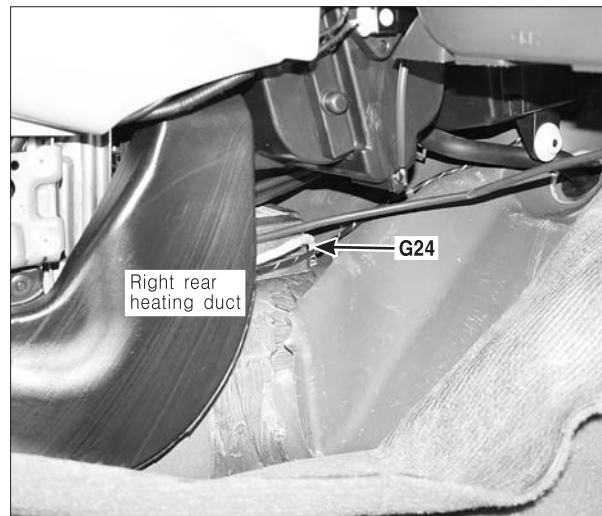
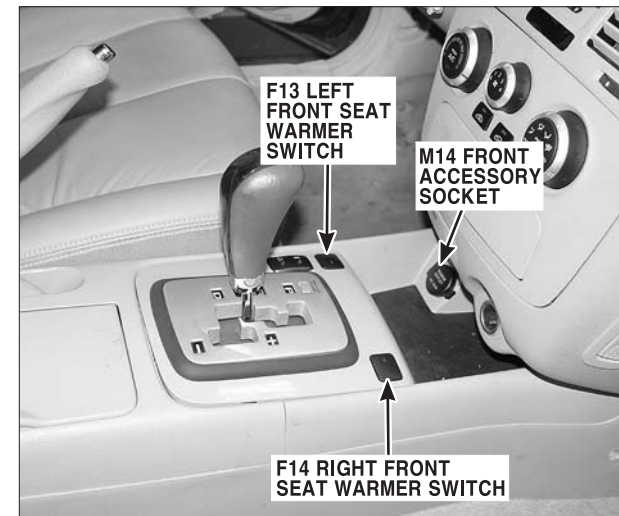

PHOTO.66



# COMPONENT LOCATIONS

## COMPONENT LOCATIONS (12)

CL-12

PHOTO.67

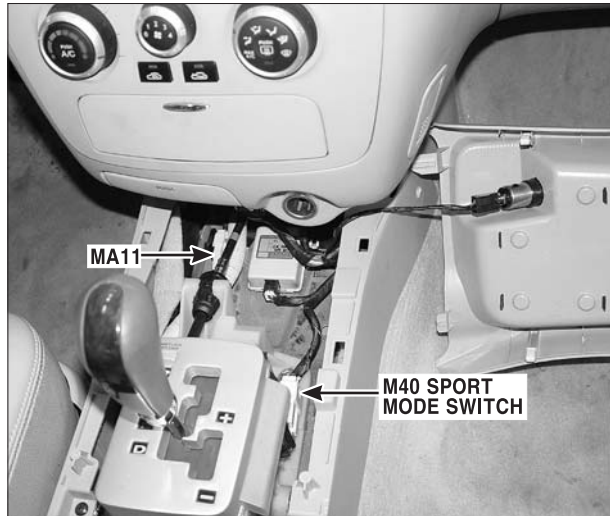

PHOTO.68

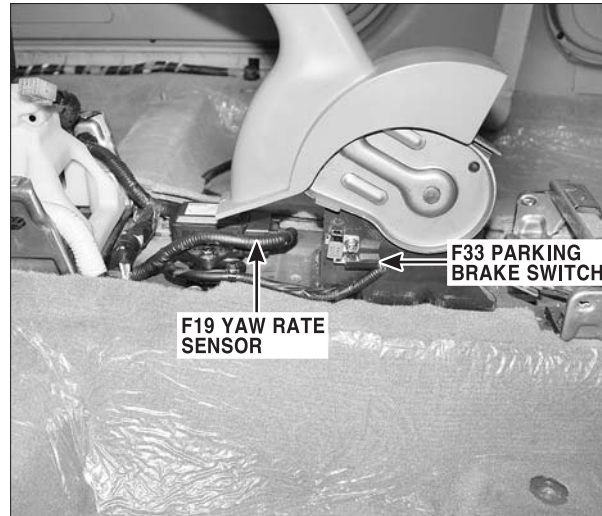

PHOTO.69



PHOTO.70

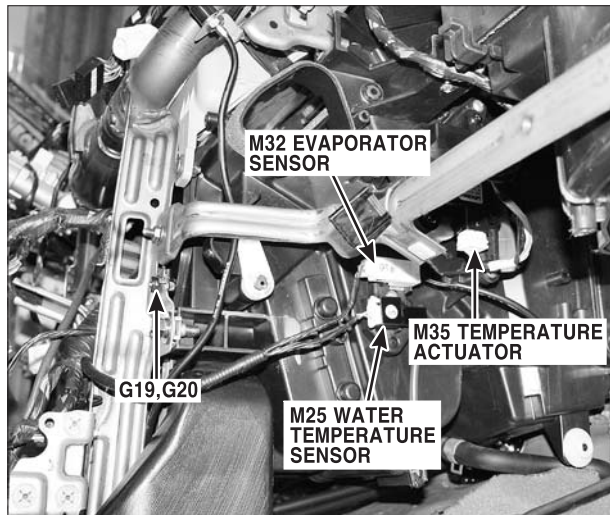

PHOTO.71

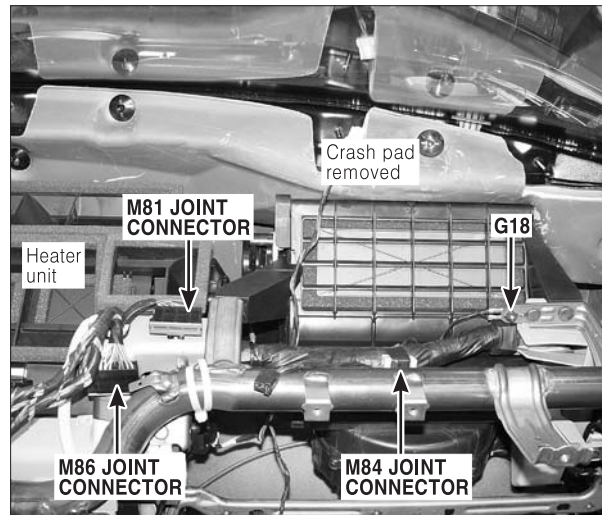
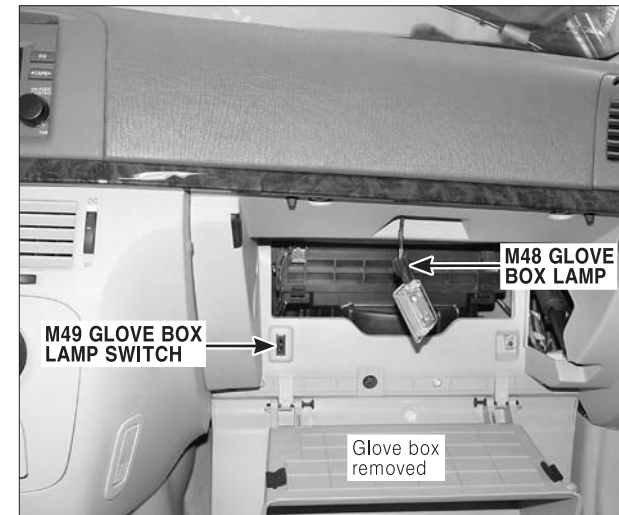

PHOTO.72



# COMPONENT LOCATIONS

## COMPONENT LOCATIONS (13)

CL-13

PHOTO.73

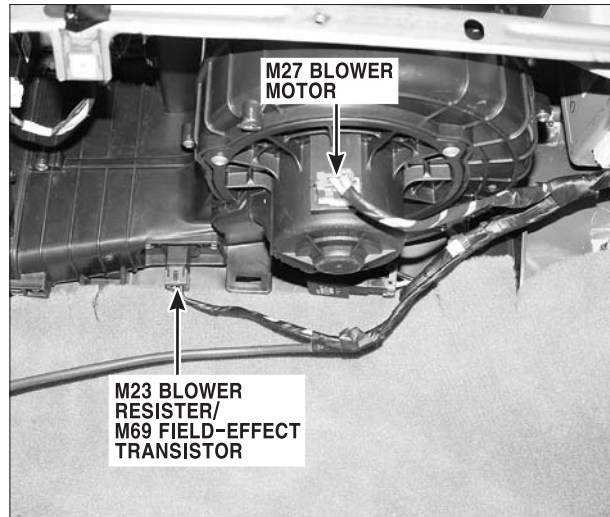

PHOTO.74

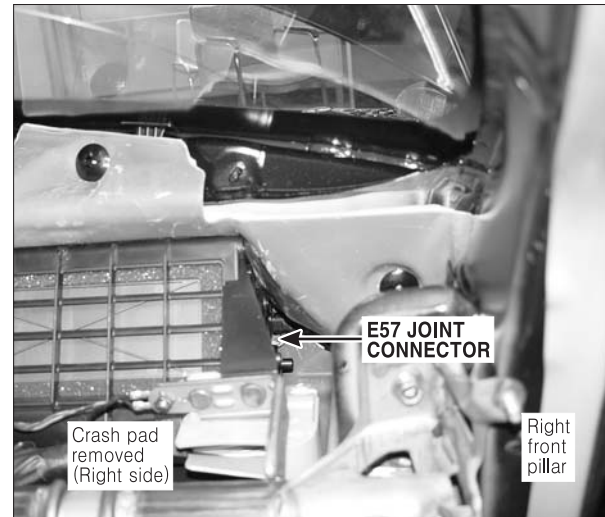

PHOTO.75

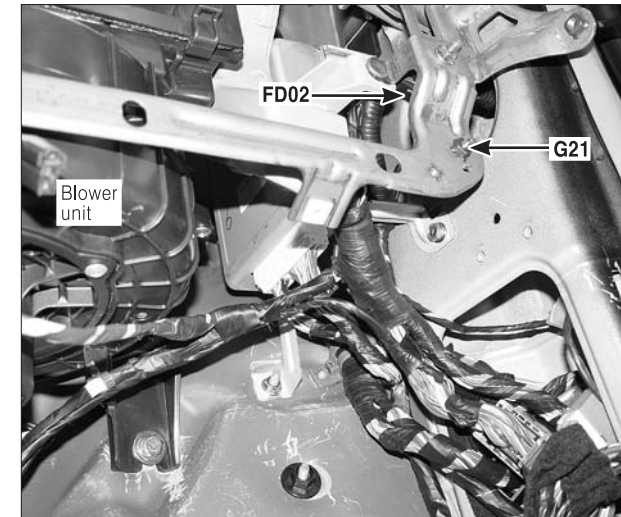

PHOTO.76

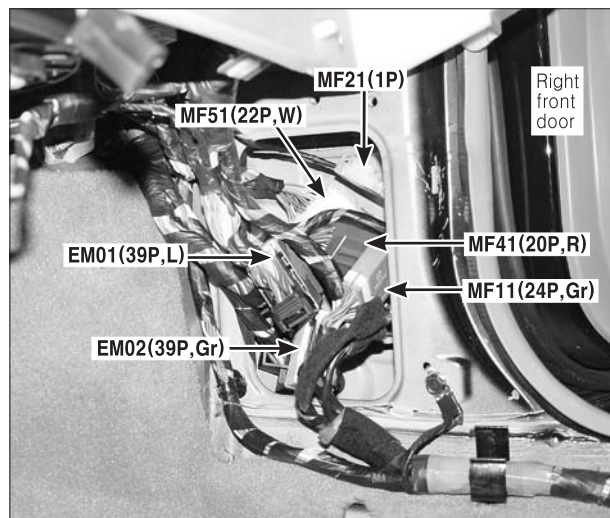
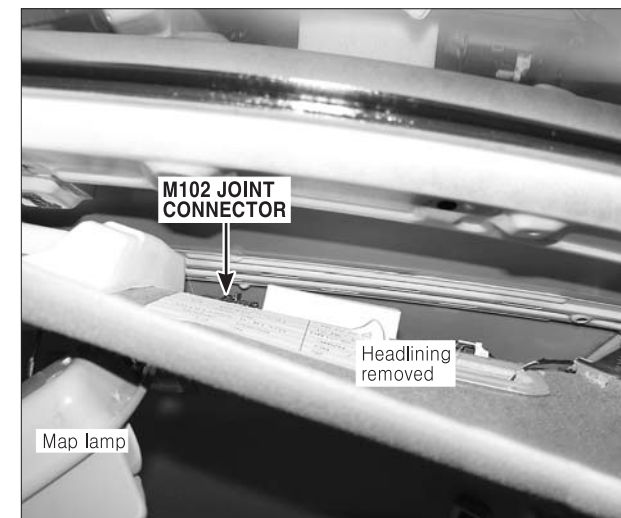

PHOTO.77



PHOTO.78



# COMPONENT LOCATIONS

## COMPONENT LOCATIONS (14)

CL-14

PHOTO.79



PHOTO.80



PHOTO.81

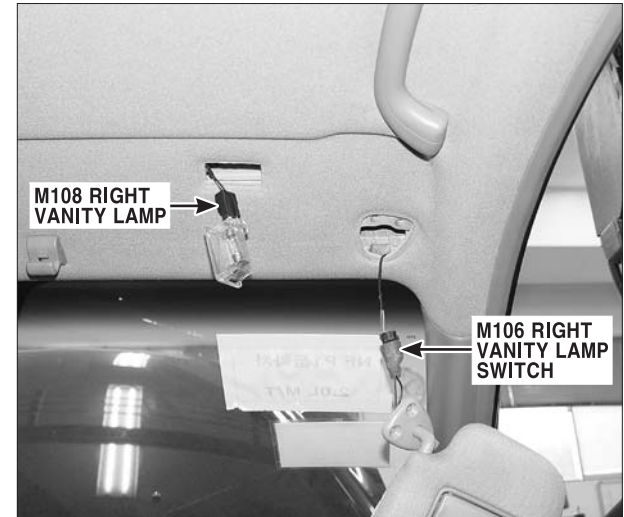

PHOTO.82



PHOTO.83

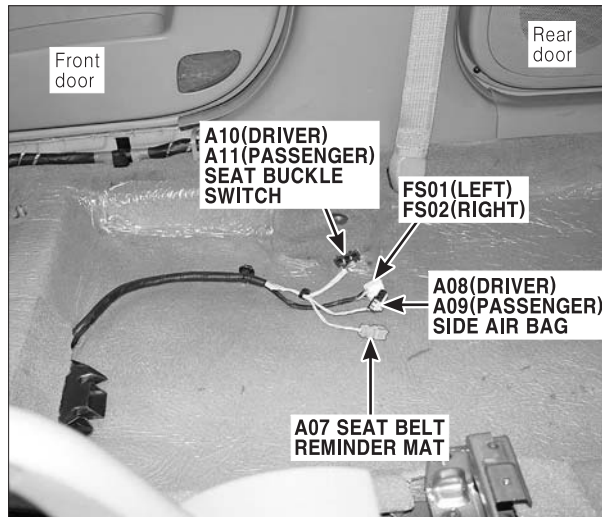
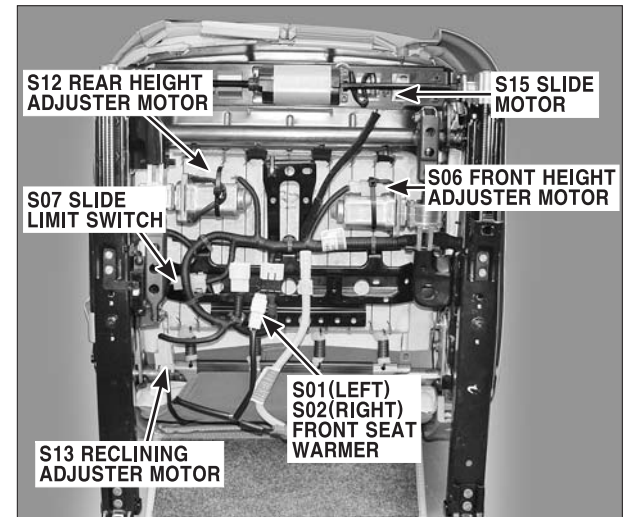

PHOTO.84



# COMPONENT LOCATIONS

## COMPONENT LOCATIONS (15)

CL-15

PHOTO.85

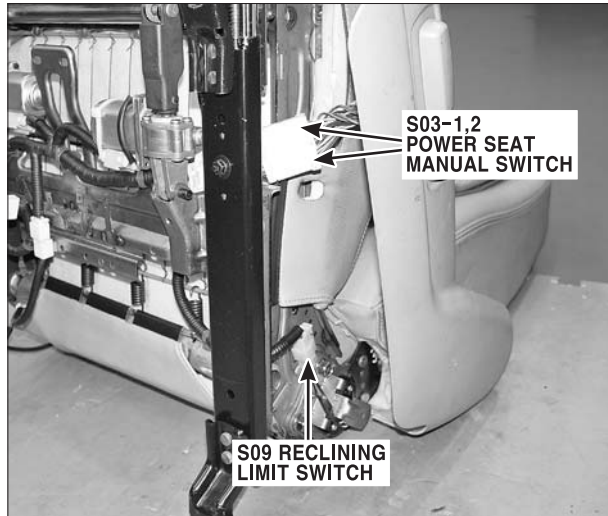

PHOTO.86

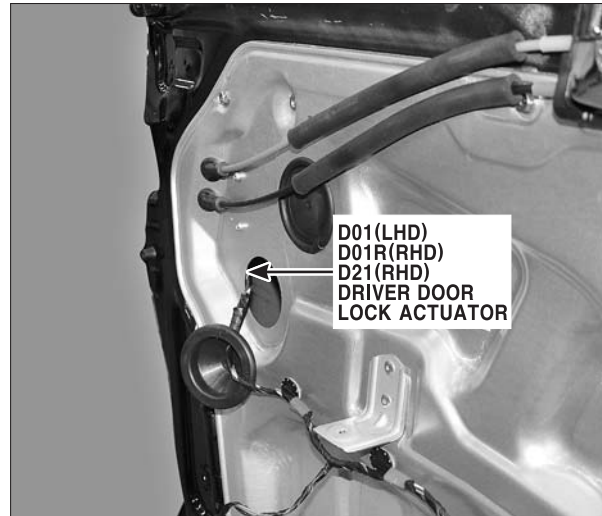

PHOTO.87

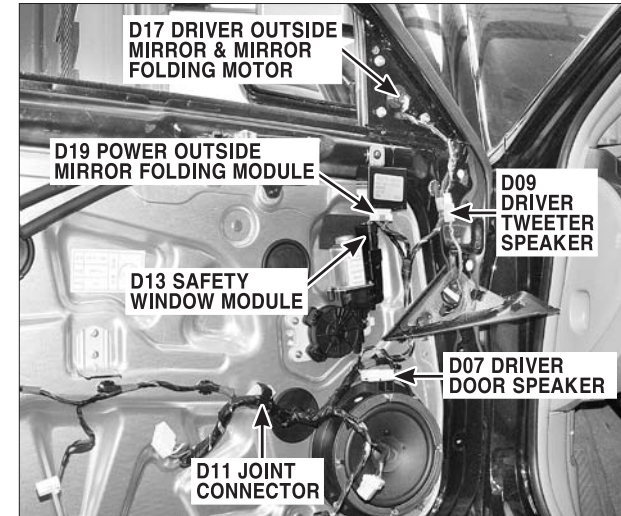

PHOTO.88

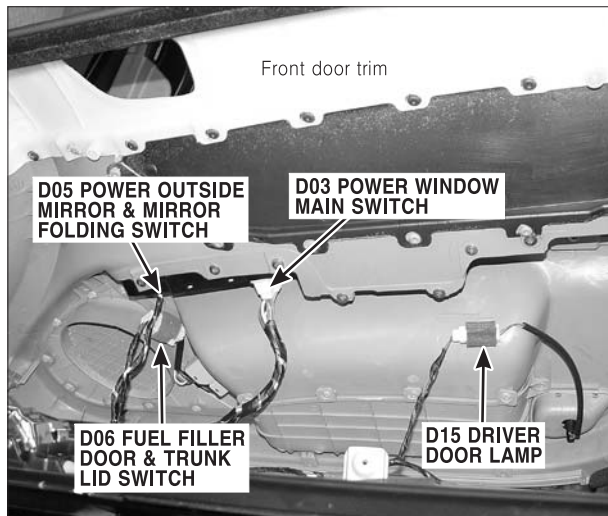

PHOTO.89

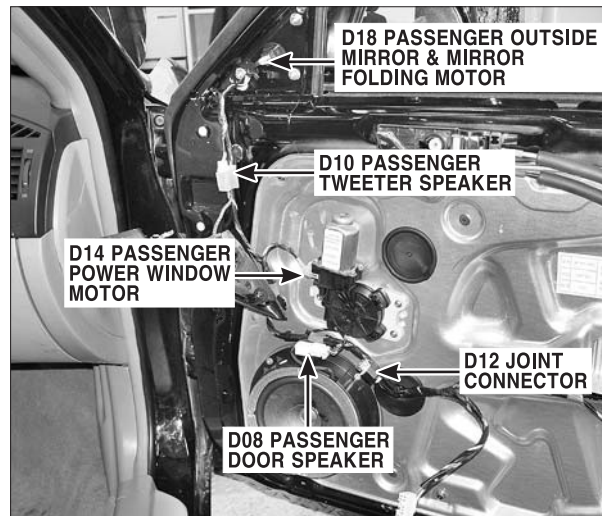
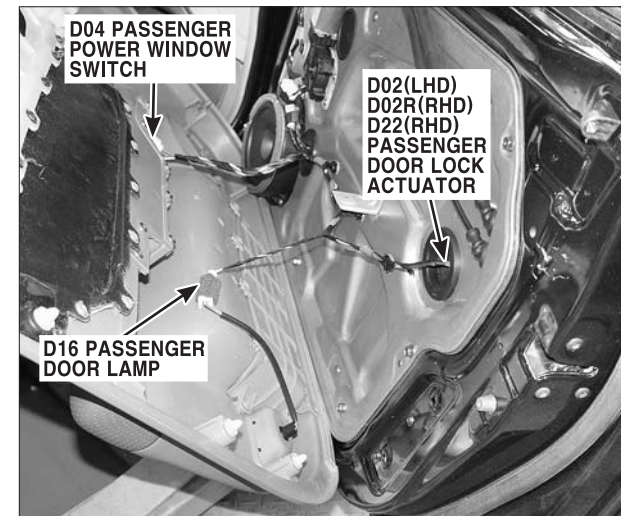

PHOTO.90



**COMPONENT LOCATIONS**

**COMPONENT LOCATIONS (16)**

**CL-16**

**PHOTO.91**

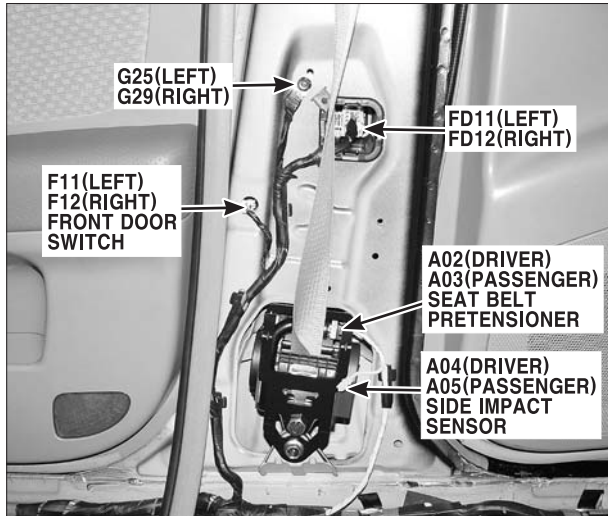

**PHOTO.92**

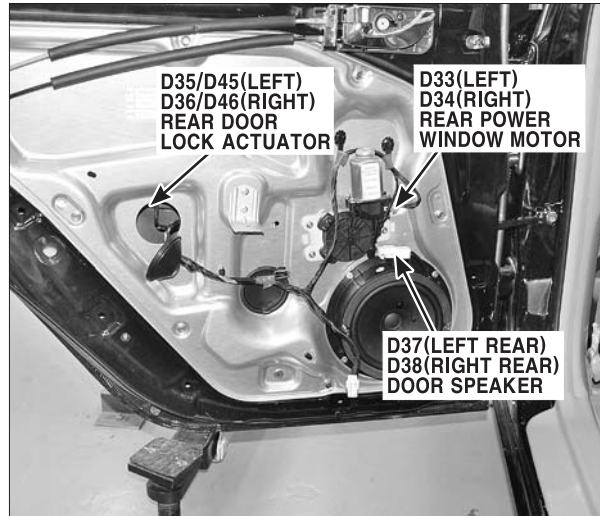

**PHOTO.93**

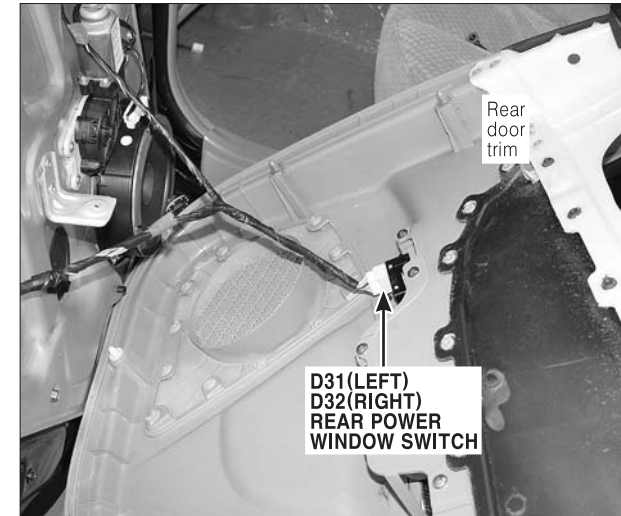

**PHOTO.94**

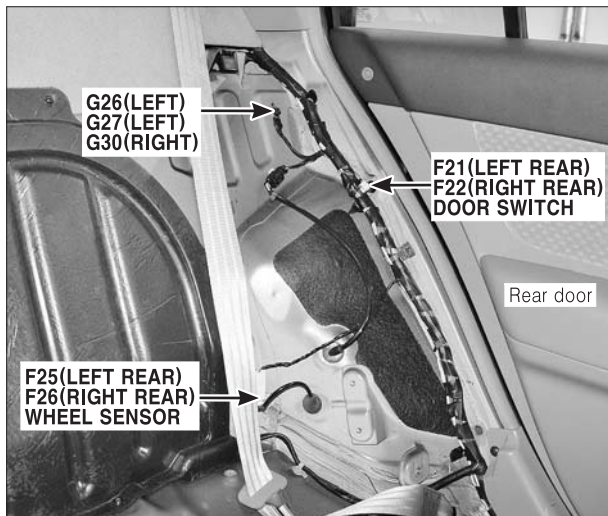

**PHOTO.95**

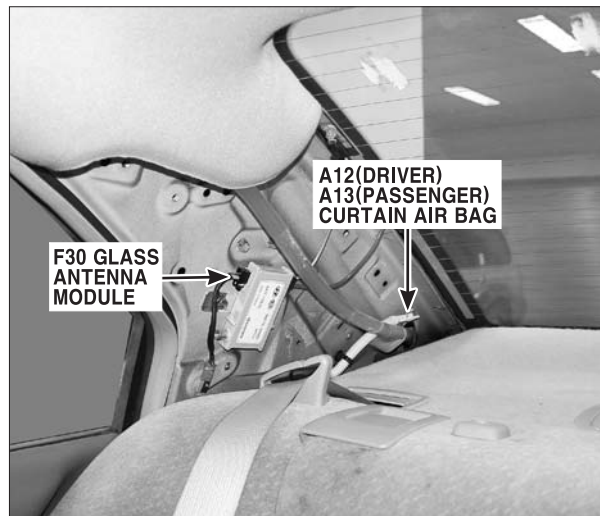

**PHOTO.96**

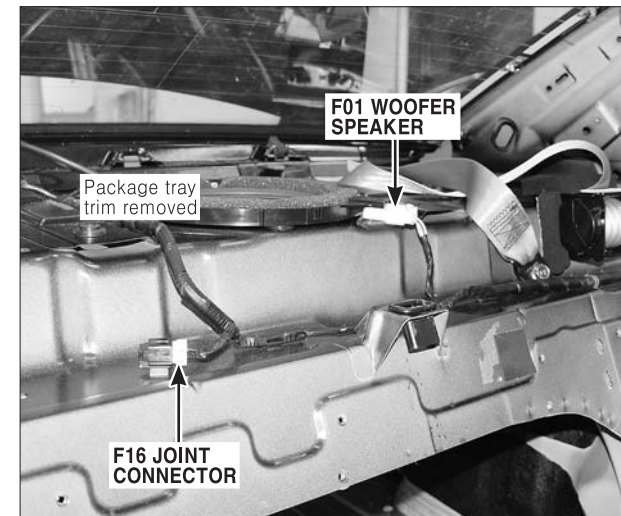

**COMPONENT LOCATIONS**

**COMPONENT LOCATIONS (17)**

**CL-17**

**PHOTO.97**

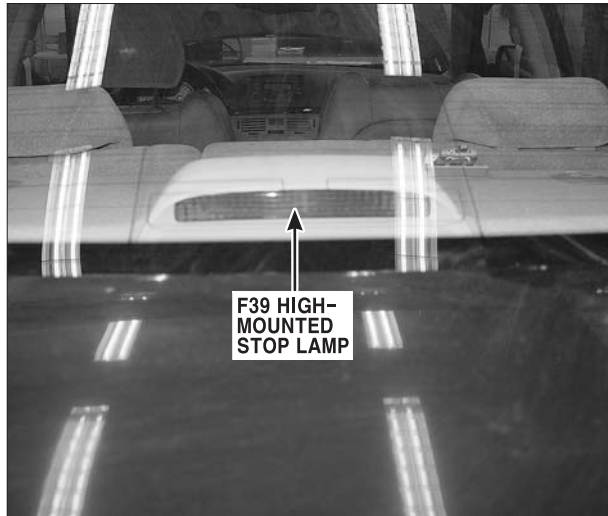

**PHOTO.98**



**PHOTO.99**

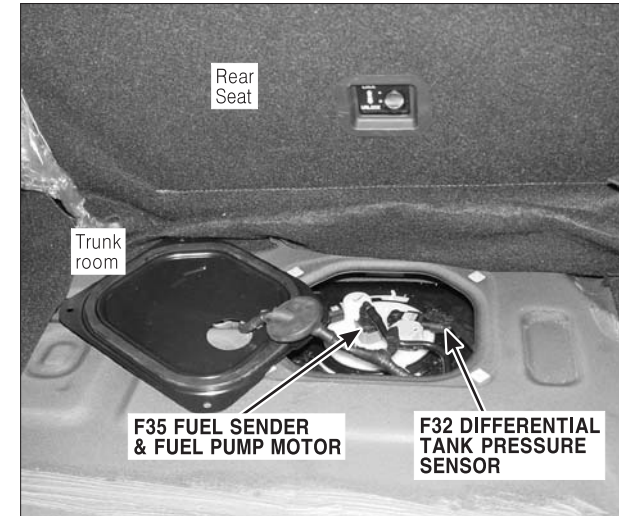

**PHOTO.100**

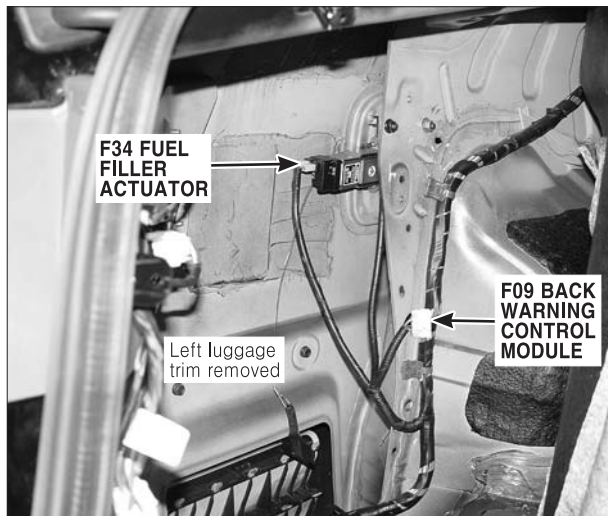

**PHOTO.101**

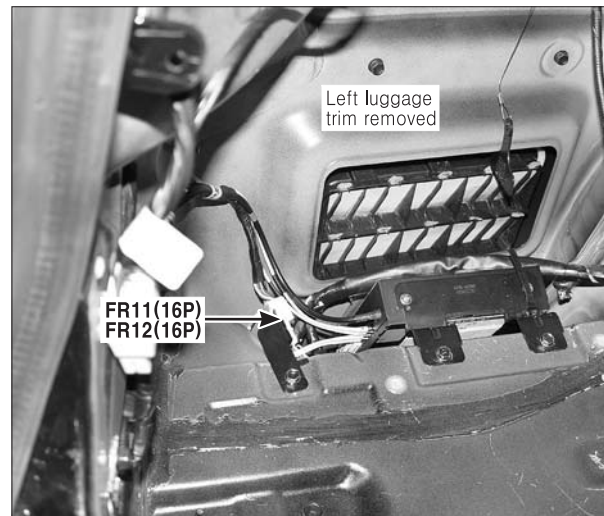

**PHOTO.102**

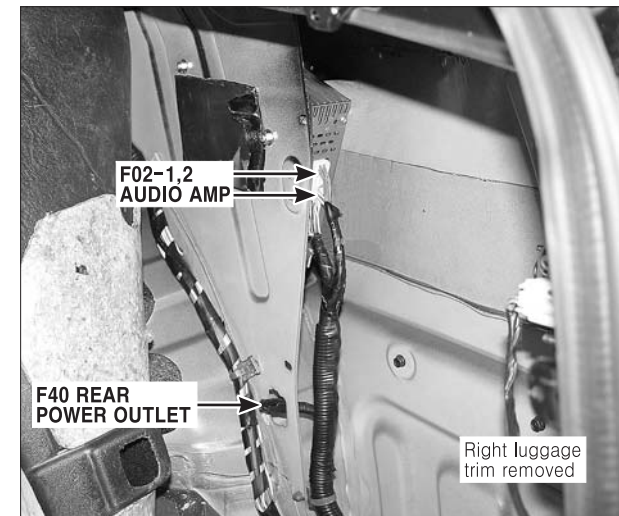



# COMPONENT LOCATIONS

## COMPONENT LOCATIONS (18)

CL-18

PHOTO.103

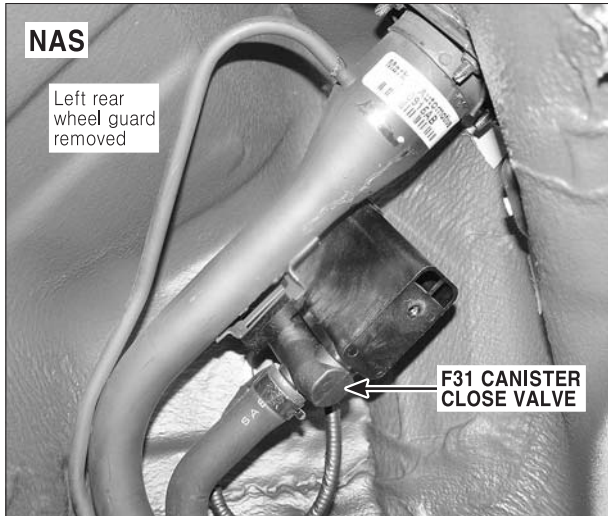

PHOTO.104

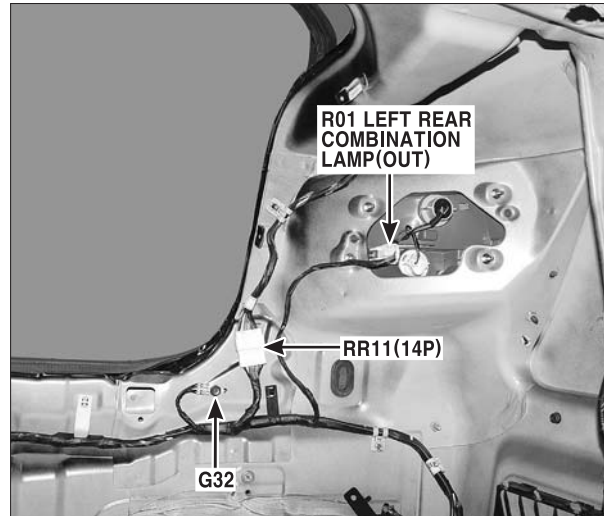

PHOTO.105

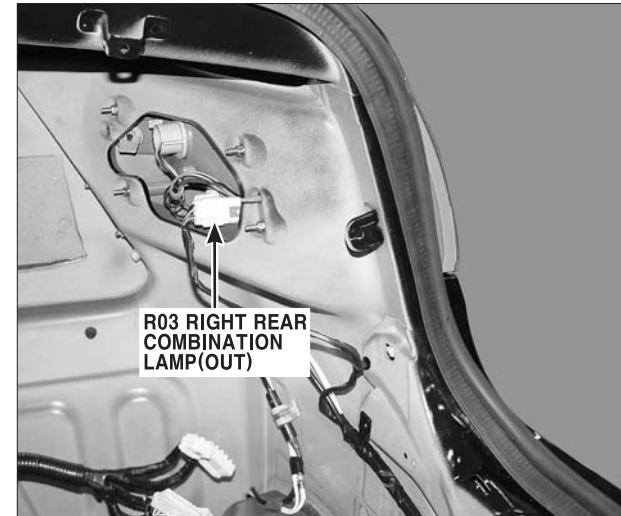

PHOTO.106

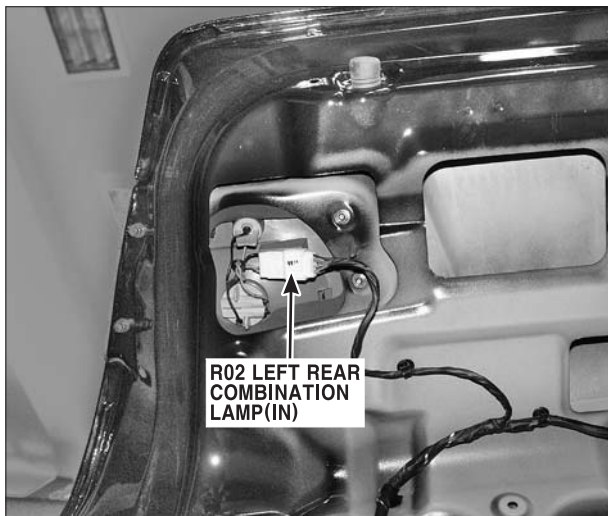

PHOTO.107

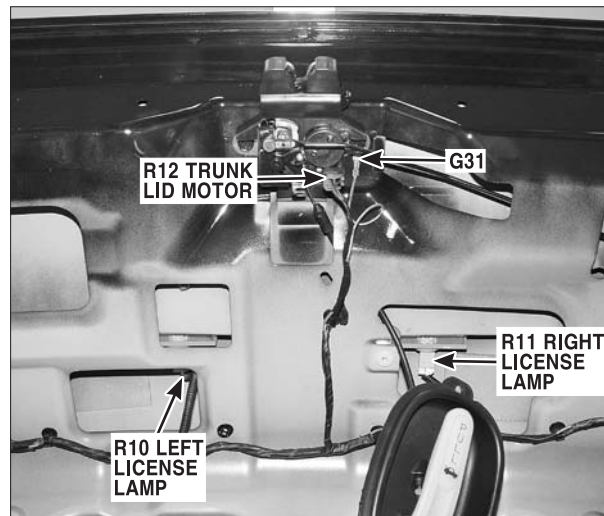
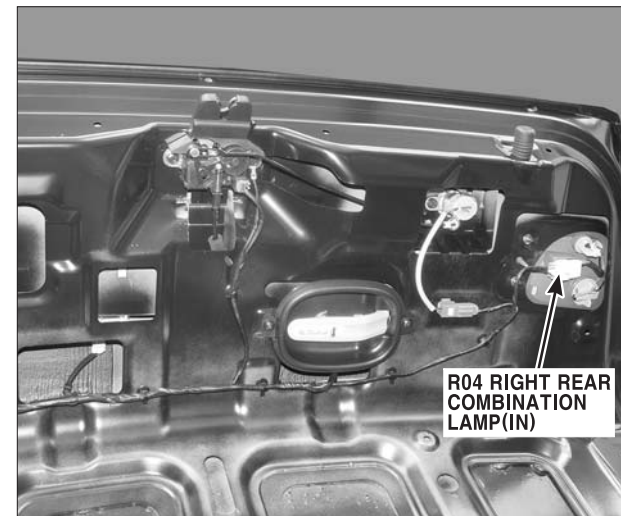

PHOTO.108



# COMPONENT LOCATIONS

## COMPONENT LOCATIONS (19)

CL-19

PHOTO.109



PHOTO.110

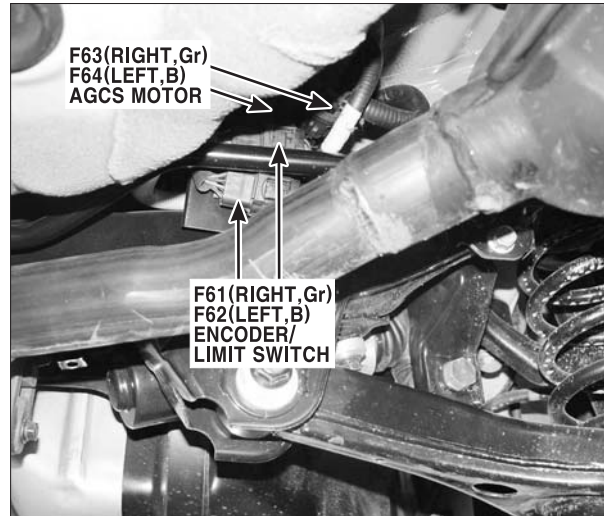

PHOTO.111

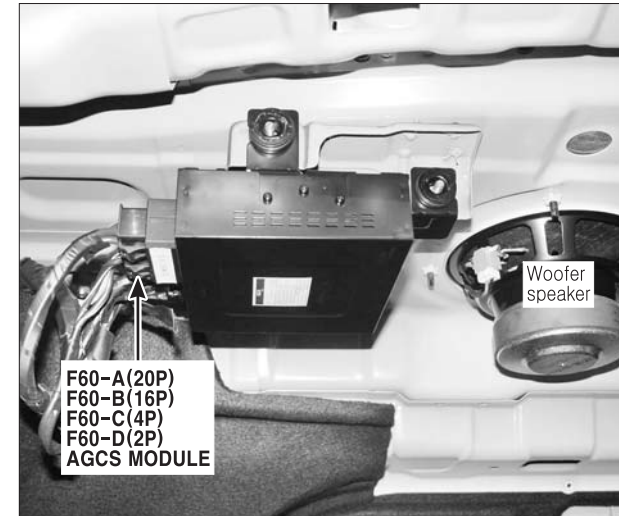

PHOTO.112

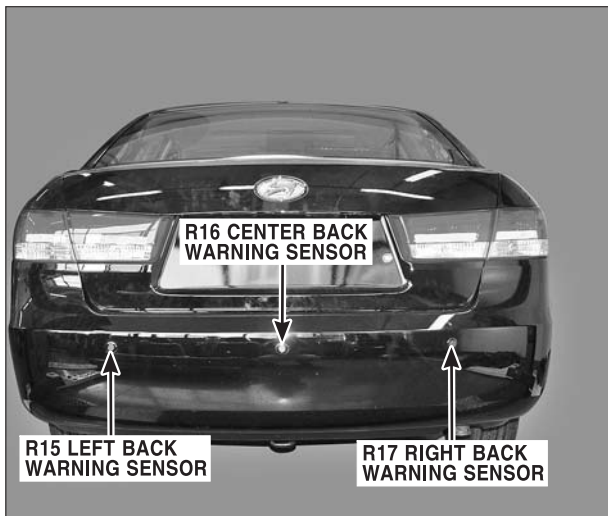

PHOTO.113

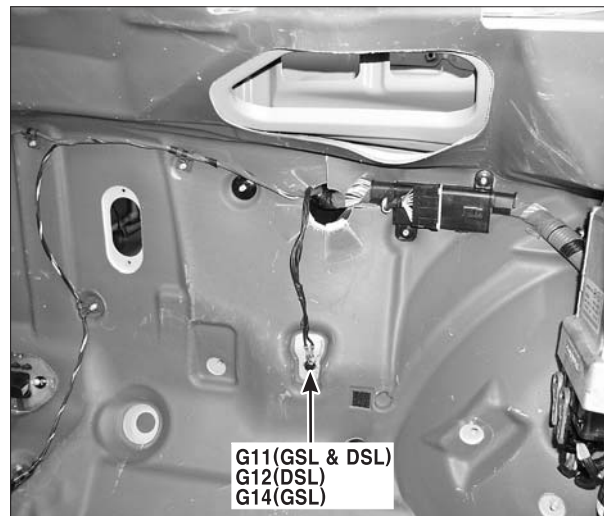
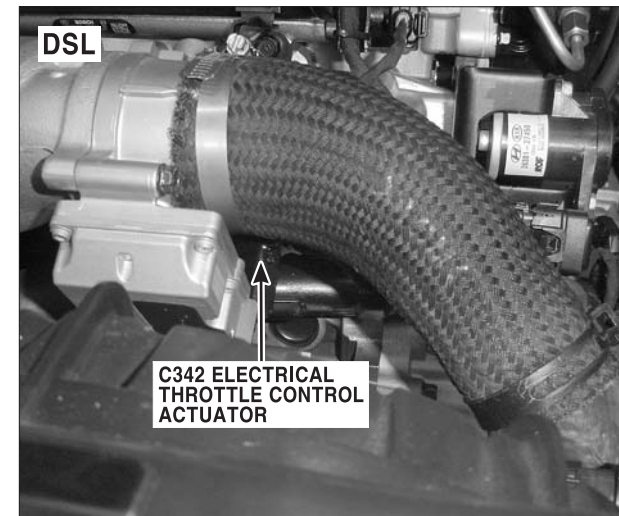

PHOTO.114



# COMPONENT LOCATIONS

## COMPONENT LOCATIONS (20)

CL-20

PHOTO.115

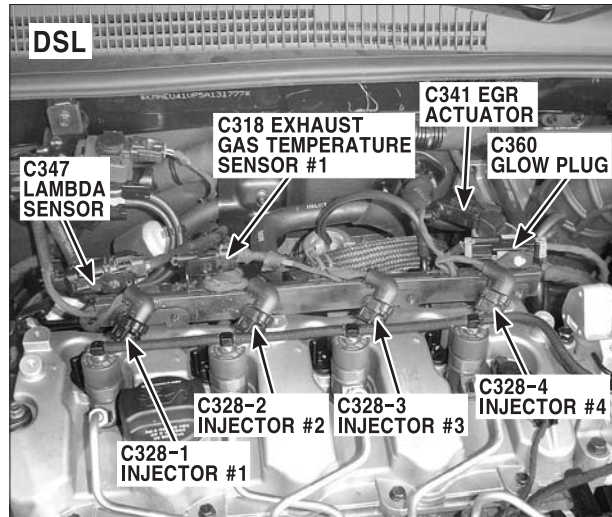

PHOTO.116

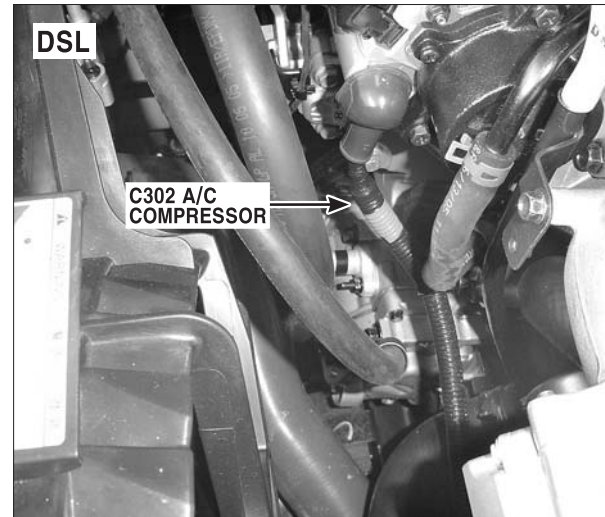

PHOTO.117

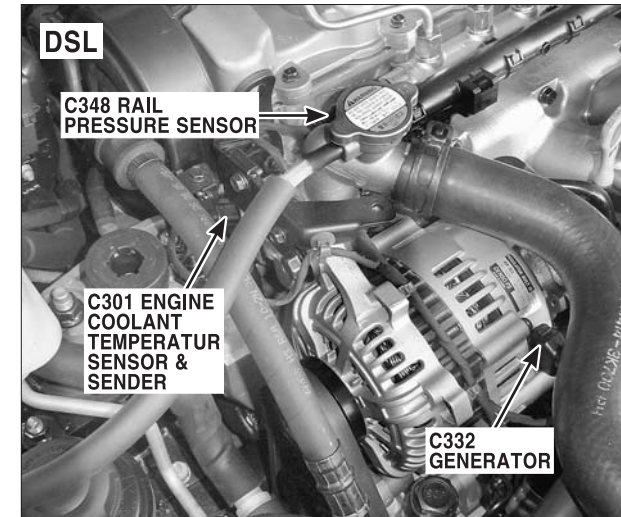

PHOTO.118

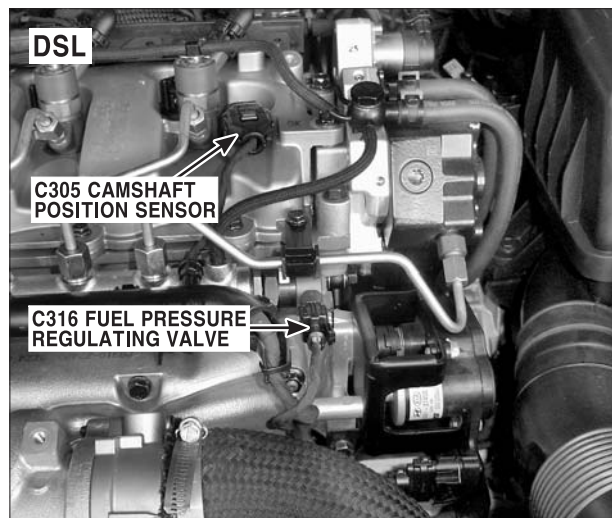

PHOTO.119

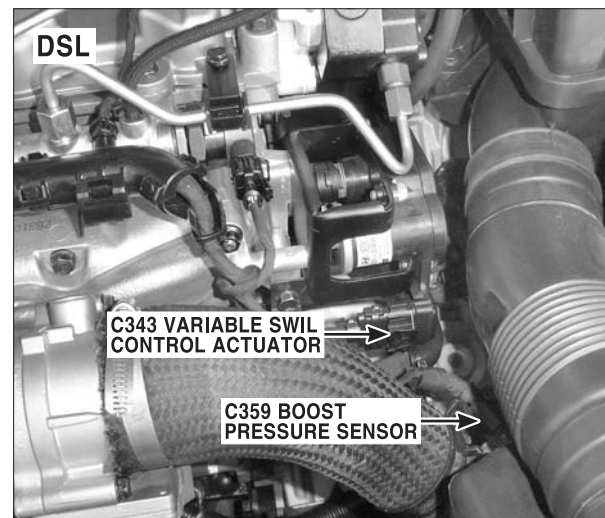
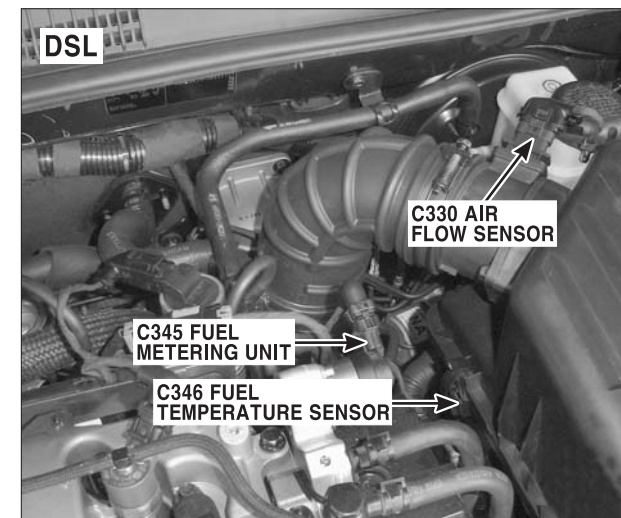

PHOTO.120



# COMPONENT LOCATIONS

## COMPONENT LOCATIONS (21)

CL-21

PHOTO.121

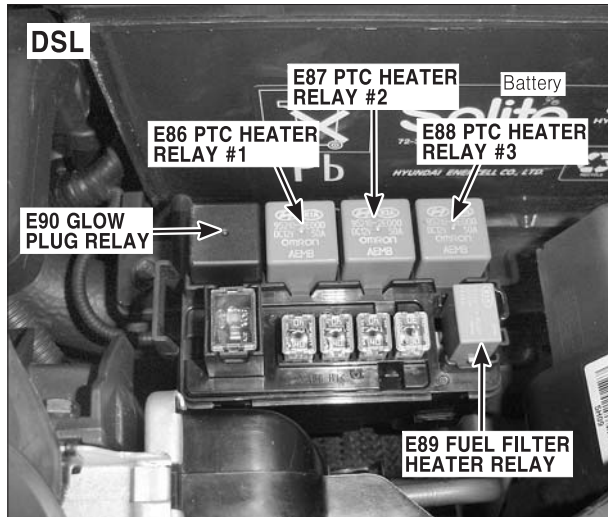

PHOTO.122

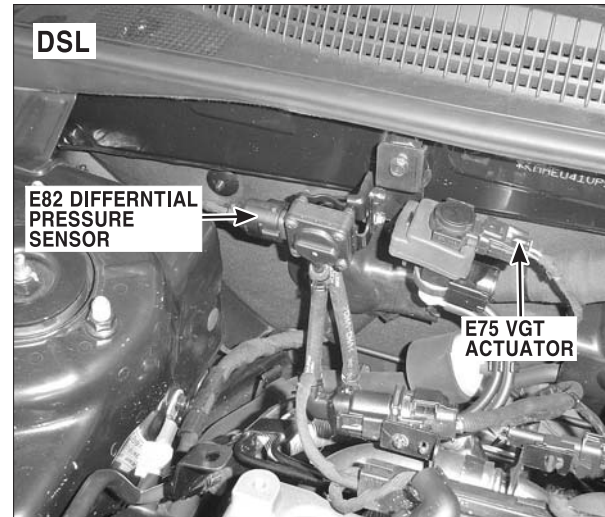

PHOTO.123

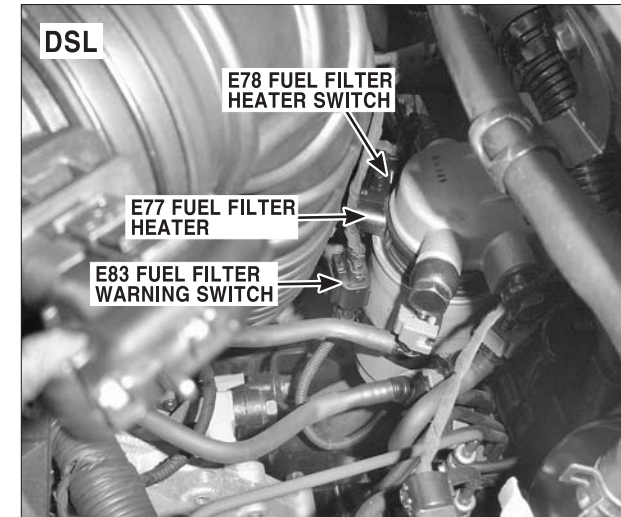

PHOTO.124



PHOTO.125

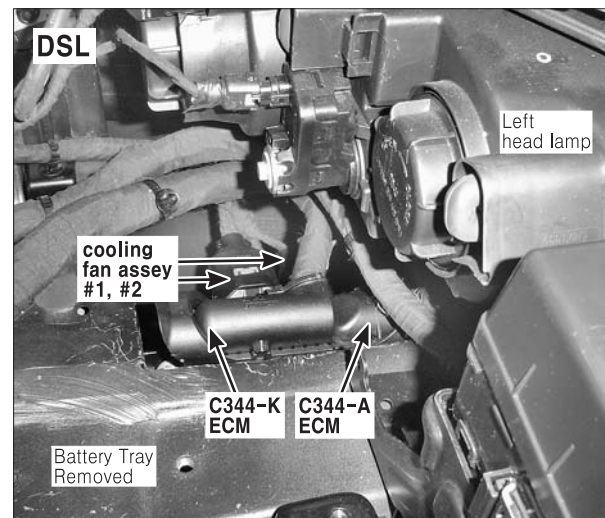
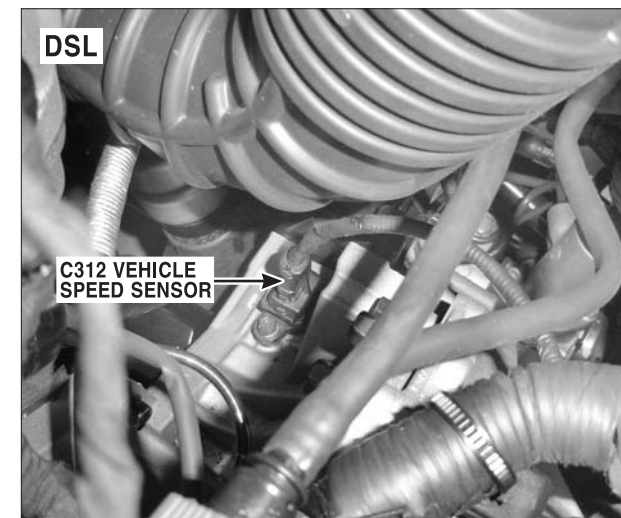

PHOTO.126



# COMPONENT LOCATIONS

## COMPONENT LOCATIONS (22)

CL-22

PHOTO.127

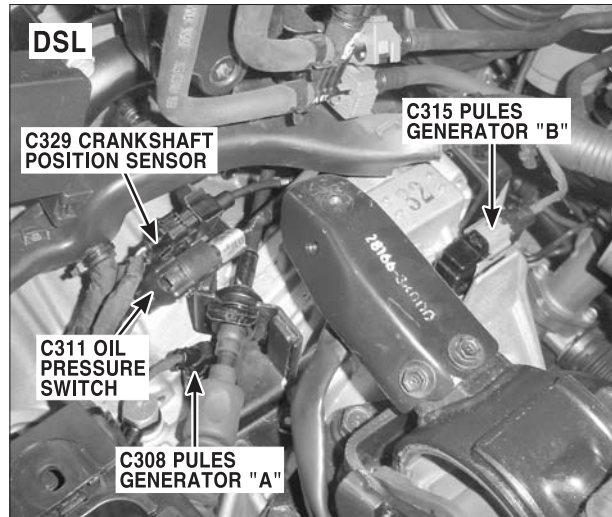

PHOTO.128

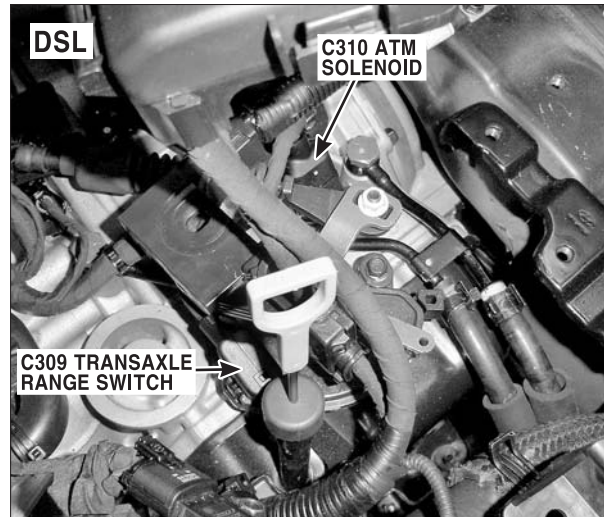

PHOTO.129

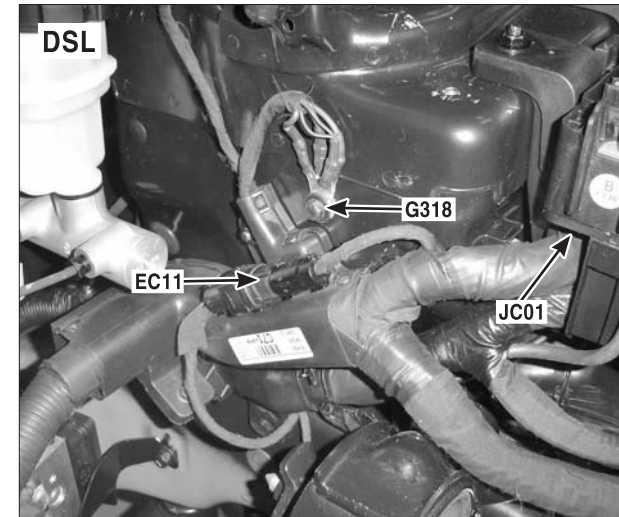

PHOTO.130



PHOTO.131

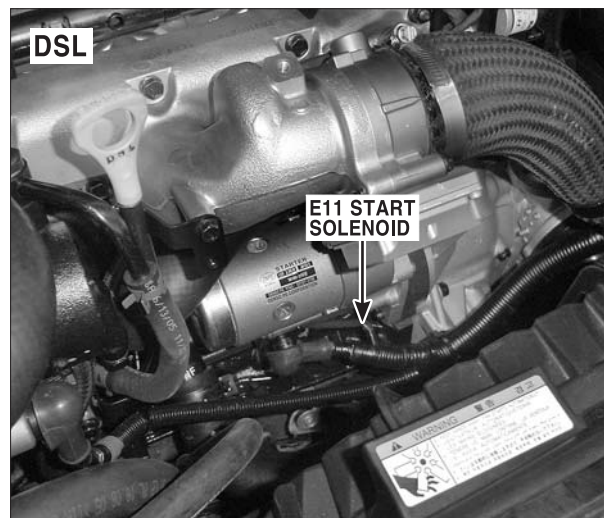
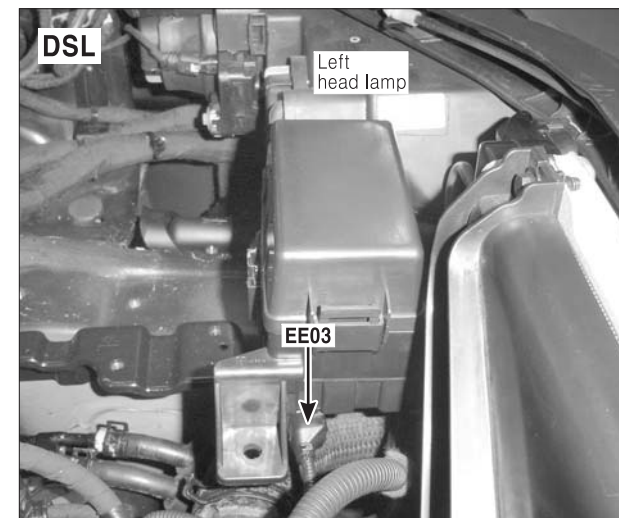

PHOTO.132



# HARNESS CONNECTOR EC81986B

HARNESS CONNECTOR (1)		CC-1
<p><b>CC101</b></p> <p>KUM_KNMWP_04F_Gr CR04M045</p>	<p><b>CC102</b></p> <p>KUM_NMWP_04F_B CR04M046</p>	<p><b>CC103</b></p> <p>PKD_GT150_04F_Gr CR04M047</p>
<p><b>EC11</b></p> <p>KET_312IWP_01F_B KET_312IWP_01M_B</p>	<p><b>EE01</b></p> <p>KUM_NMWP_08F_B KUM_NMWP_08M_B</p>	<p><b>EE02</b></p> <p>KUM_NMWP_01F_B CR01M002</p>
<p><b>EE03</b></p> <p>CR01F020 KUM_NMWP_01M_B</p>	<p><b>EF11</b></p> <p>KET_58L_01F_W KET_58L_01M_W</p>	<p><b>EM03</b></p> <p>KET_312II_04F_B KET_312II_04M_B</p>
<p><b>EM01</b></p> <p>KET_LIF0409_39F_L</p>		<p>KET_LIF0409_39M_L</p>
<p>KET_LIF0409_39F_Gr</p>		<p>KET_LIF0409_39M_Gr</p>

# HARNES CONNECTOR

## HARNES CONNECTOR (2)

CC-2

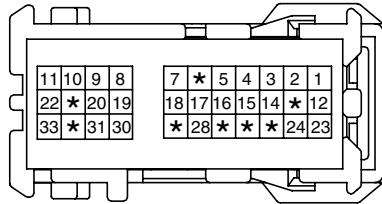

KET\_LIF0409\_33F\_B

EM11

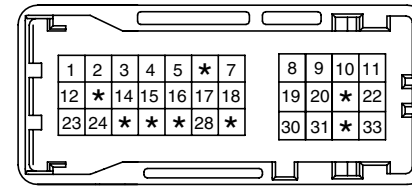

KET\_LIF0409\_33M\_B

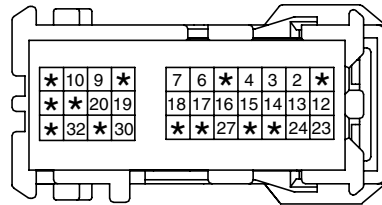

KET\_LIF0409\_33F\_W

EM21

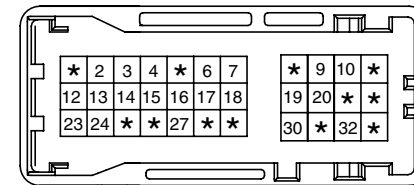

KET\_LIF0409\_33M\_W

EM31

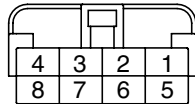

KET\_250DL\_08F\_W

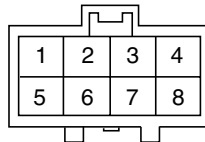

KET\_250DL\_08M\_W

EM41

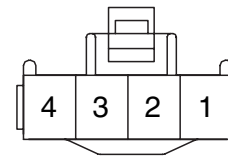

KET\_312II\_04F\_W

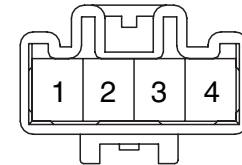

KET\_312II\_04M\_W

FD01

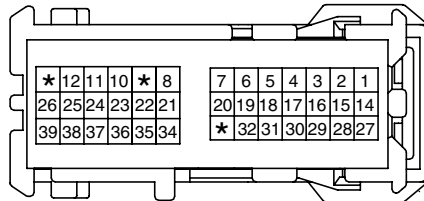

KET\_LIF0409\_39F\_W

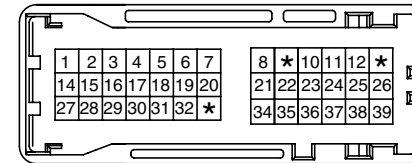

KET\_LIF0409\_39M\_W

FD02

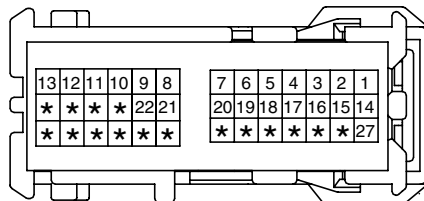

KET\_LIF0409\_39F\_W

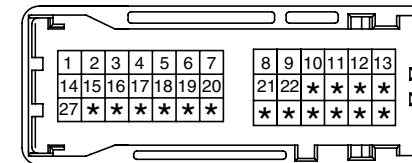

KET\_LIF0409\_39M\_W

# HARNESS CONNECTOR

## HARNESS CONNECTOR (3)

CC-3

### FD11

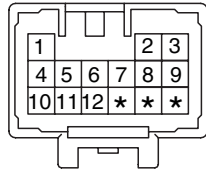

KET\_090III\_15M\_W

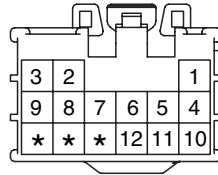

KET\_090III\_15F\_W

### FD12

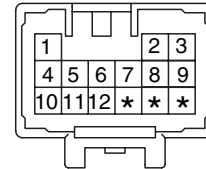

KET\_090III\_15M\_W

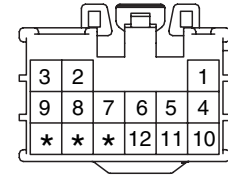

KET\_090III\_15F\_W

### FR11

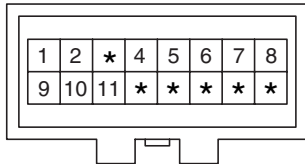

AMP\_090III\_16M\_W

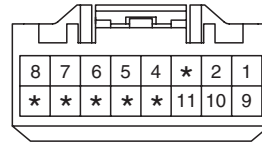

AMP\_090III\_16F\_W

### FR12

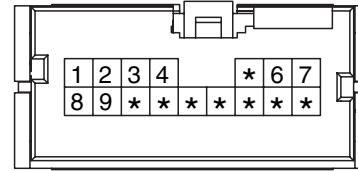

AMP\_040III\_16M\_W

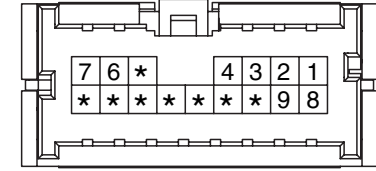

AMP\_040III\_16F\_W

### FS01

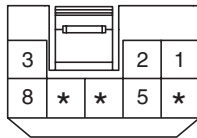

AMP\_090III\_08F\_W

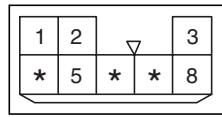

CR08M007

### FS02

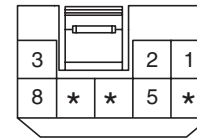

AMP\_090III\_08F\_W

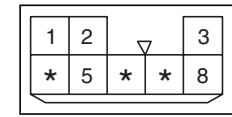

CR08M007

### MA11

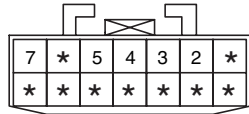

AMP\_MQS\_14F\_Y

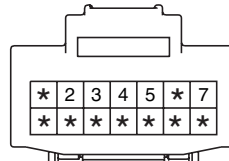

AMP\_MQS\_14M\_Y

### MF01

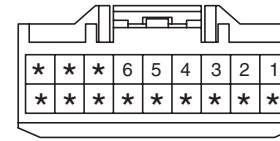

AMP\_090III\_18F\_W

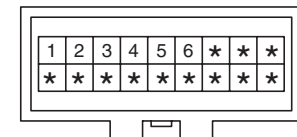

AMP\_090III\_18M\_W

### MF11

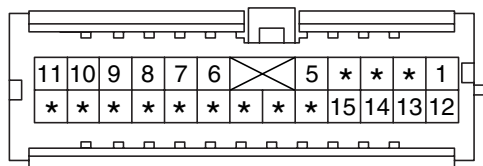

AMP\_040III\_24F\_GR

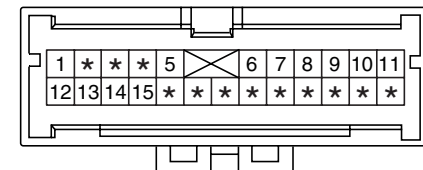

AMP\_040III\_24M\_GR



# HARNESS CONNECTOR

## HARNESS CONNECTOR (4)

CC-4

### MF21

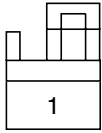

KET\_250DL\_01F\_W

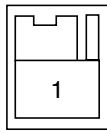

KET\_250DL\_01M\_W

### MF41

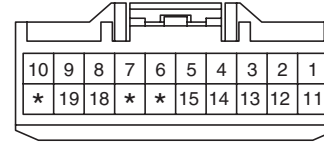

AMP\_090III\_20F\_R

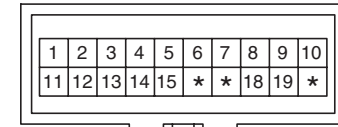

AMP\_090III\_20M\_R

### MF51

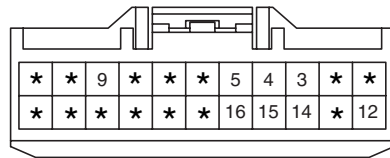

AMP\_090III\_22F\_W

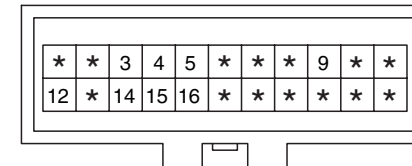

AMP\_090III\_22M\_W

### MF61

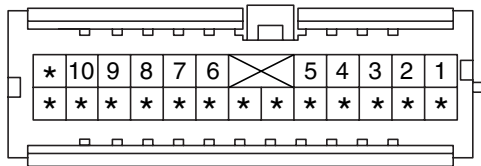

AMP\_040III\_24F\_GR

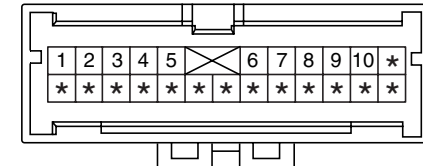

AMP\_040III\_24M\_GR

### MF71

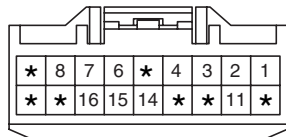

AMP\_090III\_18F\_BR

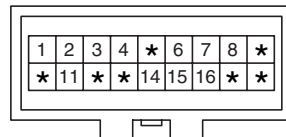

AMP\_090III\_18M\_BR

### MF81

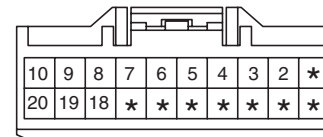

AMP\_090III\_20F\_R

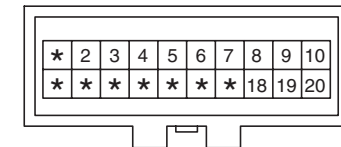

AMP\_090III\_20M\_R

### MF91

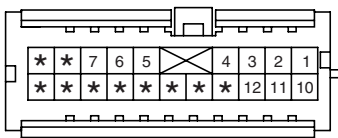

AMP\_040III\_20F\_BR

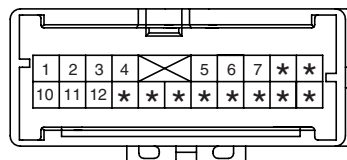

AMP\_040III\_20M\_BR

### RR11

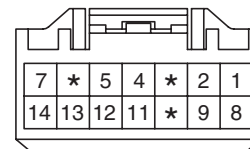

AMP\_090III\_14F\_W

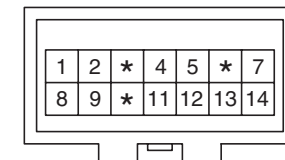

AMP\_090III\_14M\_W

ENGINE COMPARTMENT JUNCTION BLOCK (1)

**GASOLINE**

JC01

JE01

JE02

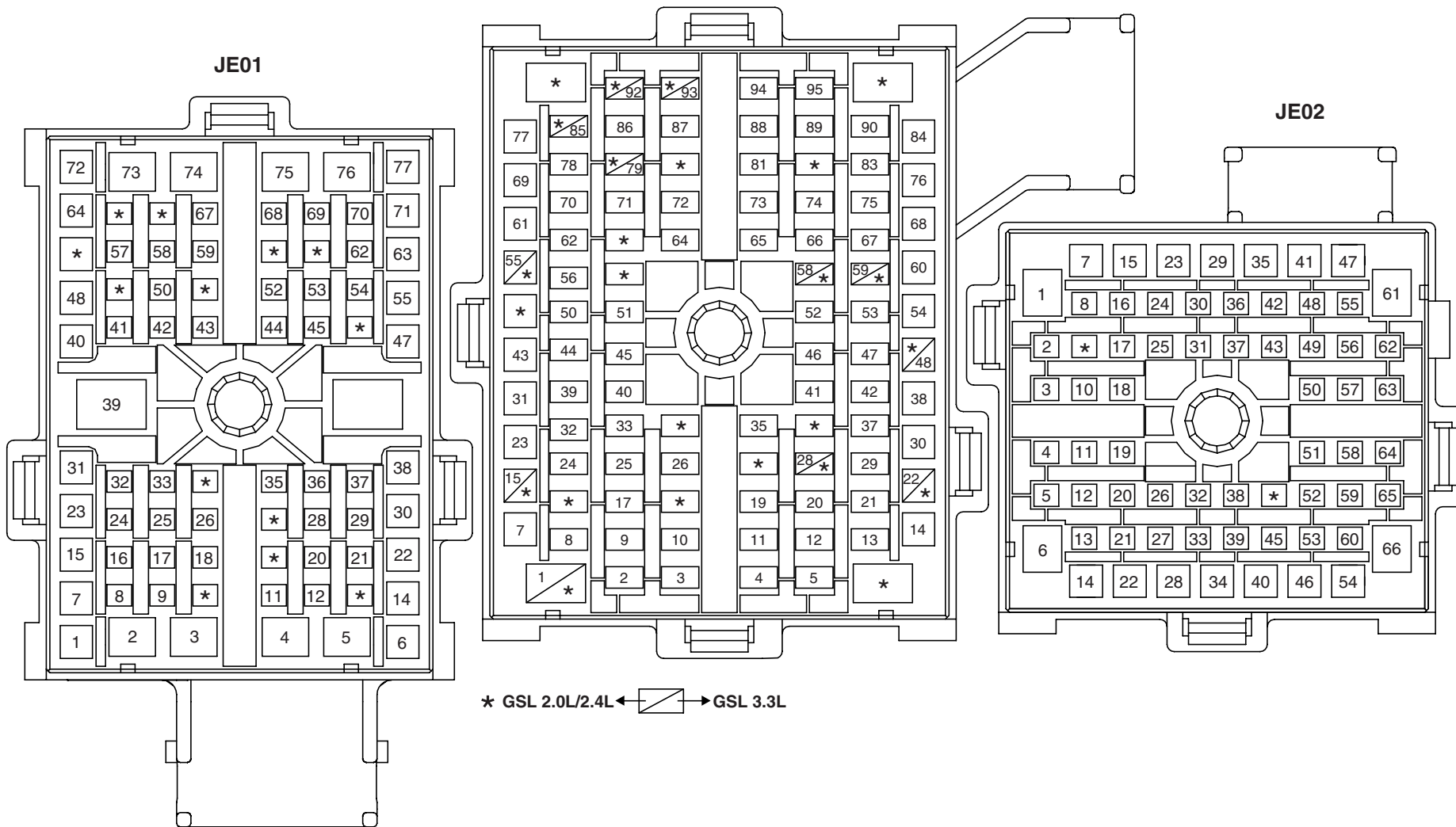

AMP\_MULBOX\_77F\_B

AMP\_MULBOX\_96F\_B

AMP\_MULBOX\_66F\_B\_C

# ENGINE COMPARTMENT JUNCTION BLOCK

## ENGINE COMPARTMENT JUNCTION BLOCK (2)

CC-6

**DIESEL**

JC01

JE01

JE02

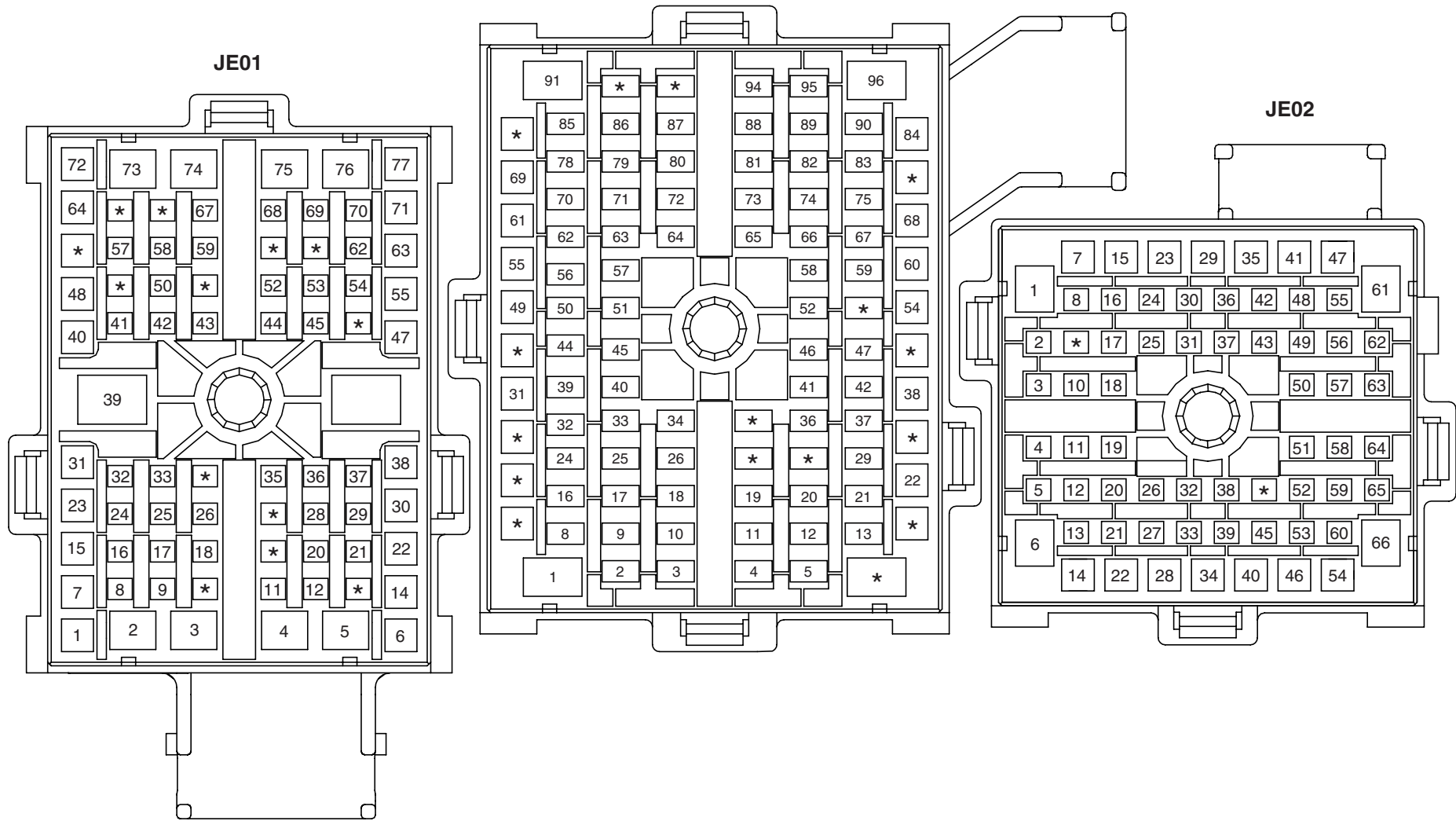

AMP\_MULBOX\_77F\_B

AMP\_MULBOX\_96F\_B

AMP\_MULBOX\_66F\_B\_C

**PASSENGER COMPARTMENT JUNCTION BLOCK** E18F365B

<b>PASSENGER COMPARTMENT JUNCTION BLOCK (1)</b>			<b>CC-7</b>
<p style="text-align: center;"><b>I/P-A</b></p> <p style="text-align: right; font-size: small;">AMP_0925_18F_W</p>	<p style="text-align: center;"><b>I/P-B</b></p> <p style="text-align: right; font-size: small;">AMP_090III_18F_W</p>	<p style="text-align: center;"><b>I/P-C</b></p> <p style="text-align: right; font-size: small;">AMP_0925_16F_W</p>	
<p style="text-align: center;"><b>I/P-D</b></p> <p style="text-align: right; font-size: small;">AMP_0925_20F_W</p>	<p style="text-align: center;"><b>I/P-E</b></p> <p style="text-align: right; font-size: small;">AMP_090III_20F_W</p>	<p style="text-align: center;"><b>I/P-F</b></p> <p style="text-align: right; font-size: small;">KET_58L_01F_W</p>	
<p style="text-align: center;"><b>I/P-G</b></p> <p style="text-align: right; font-size: small;">AMP_250_04F_W_SPT</p>	<p style="text-align: center;"><b>I/P-J</b></p> <p style="text-align: right; font-size: small;">AMP_0925_14F_W</p>	<p style="text-align: center;"><b>I/P-K(LHD)</b></p> <p style="text-align: right; font-size: small;">AMP_0925_12F_W</p>	
<p style="text-align: center;"><b>I/P-K(RHD)</b></p> <p style="text-align: right; font-size: small;">AMP_0925_12F_W</p>	<p style="text-align: center;"><b>I/P-L</b></p> <p style="text-align: right; font-size: small;">AMP_090III_12F_W</p>	<p style="font-size: large; font-weight: bold;">BLANK</p>	

**JOINT CONNECTOR (1)** **CC-8**

**D11**

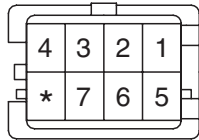

KET\_070\_08F\_W\_JCH

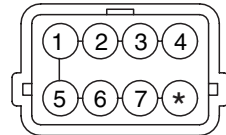

KET\_070\_8P\_CAP

**D12**

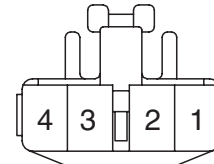

KET\_090II\_04F\_W

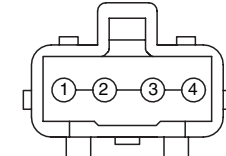

KET\_090II\_4P\_CAP

**E55**

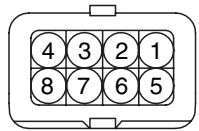

KET\_090IWP\_08F\_B\_JCH

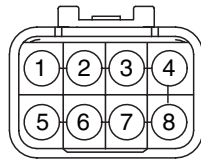

KET\_090IWP\_08M\_B\_JCH

**BLANK**

**E57**

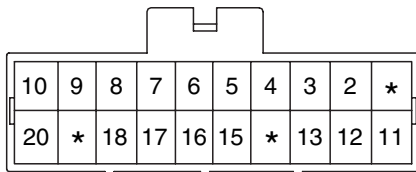

KET\_090II\_20F\_B\_JCH

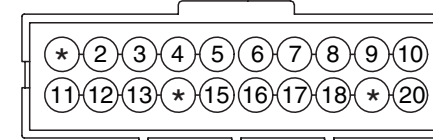

KET\_090II\_20P\_CAP\_Gr

**F16**

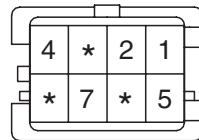

KET\_070\_08F\_W\_JCH

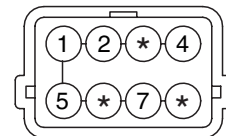

KET\_070\_8P\_CAP

**M81**

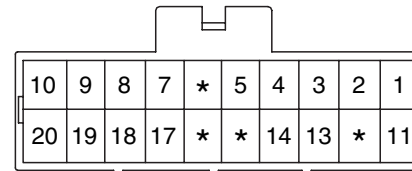

KET\_090II\_20F\_B\_JCH

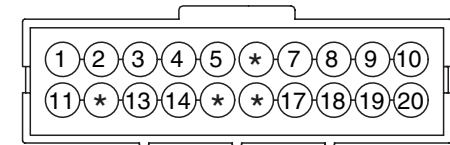

KET\_090II\_20P\_CAP\_GR

**M82**

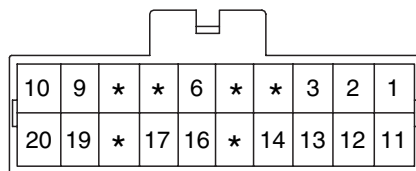

KET\_090II\_20F\_B\_JCH

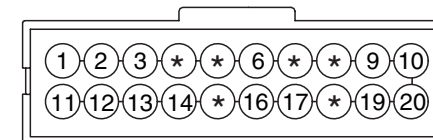

KET\_090II\_20P\_CAP\_G

# JOINT CONNECTOR

## JOINT CONNECTOR (2)

CC-9

### M83

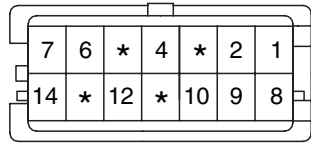

KET\_070\_14F\_W\_JCH

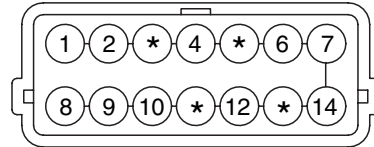

KET\_070\_14P\_CAP

### M84

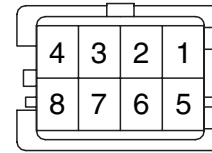

KET\_070\_08F\_B\_JCH

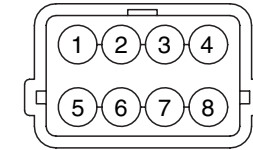

KET\_070\_08P\_CAP

### M86

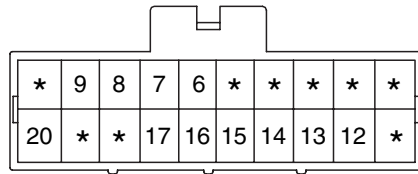

KET\_090II\_20F\_Y\_JCH

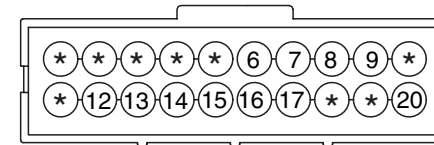

KET\_090II\_20P\_CAP\_Gr

### M87

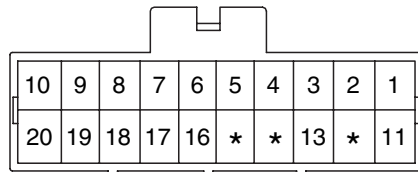

KET\_090II\_20F\_B\_JCH

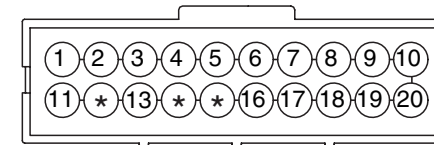

KET\_090II\_20P\_CAP\_G

### M102

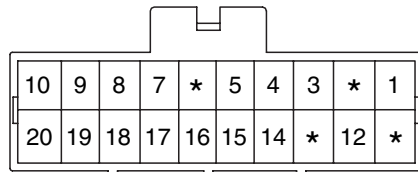

KET\_090II\_20F\_B\_JCH

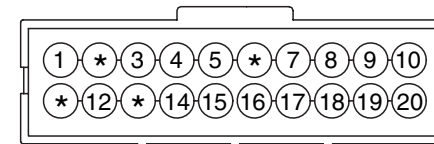

KET\_090II\_20P\_CAP\_Or

MAIN HARNESS (1)

HL-1

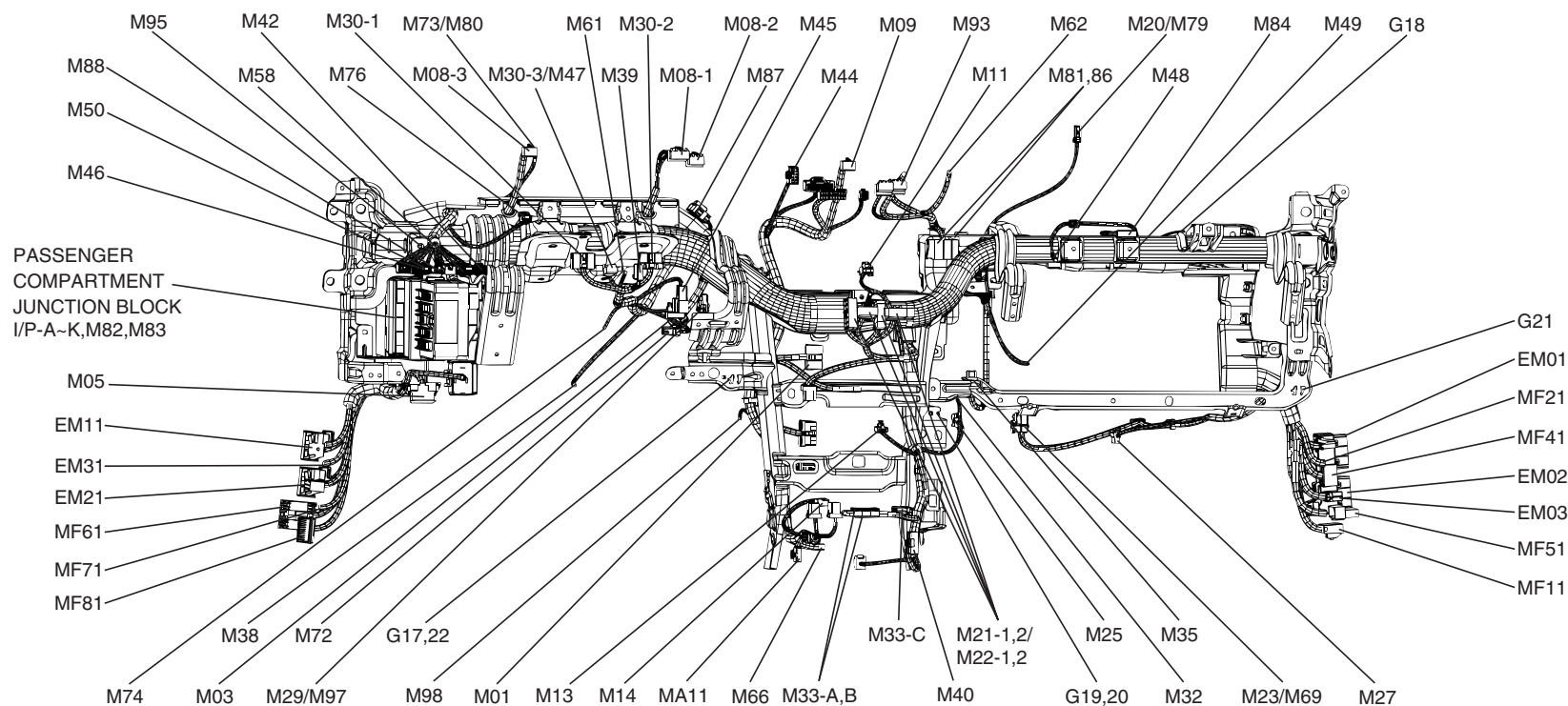

CONNECTOR BOX

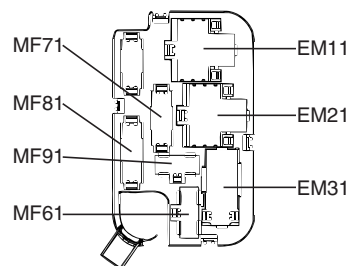

(LEFT)

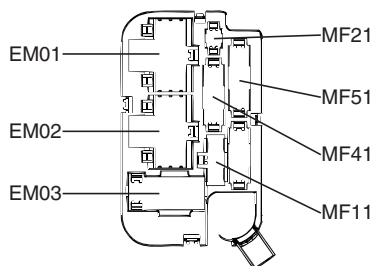

(RIGHT)

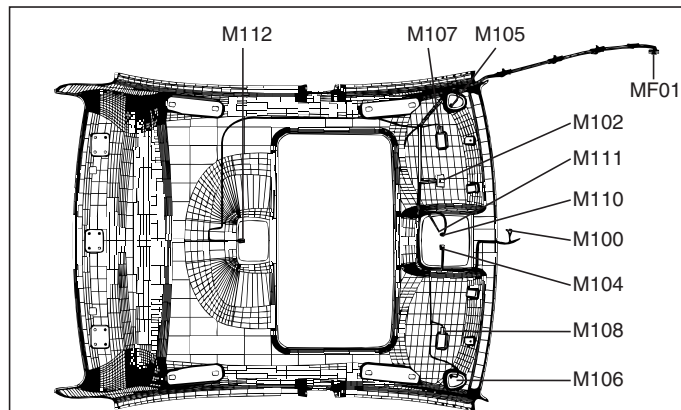

## MAIN HARNESS

### MAIN HARNESS (2)

HL-2

M01	ATM Key lock control module	M49	Glove box lamp switch	MA11	Connection with AIR BAG harness
M03	Ignition switch	M50	Rear fog lamp switch	MF11	Connection with FLOOR harness
M05	Data link connector	M54	Back warning buzzer	MF21	Connection with FLOOR harness
M08-1	Instrument cluster	M58	ESP switch	MF41	Connection with FLOOR harness
M08-2	Instrument cluster	M61	Driver air bag	MF51	Connection with FLOOR harness
M08-3	Instrument cluster	M62	Passenger air bag	MF61	Connection with FLOOR harness
M09	Audio	M64	PAB switch	MF71	Connection with FLOOR harness
M11	Digital clock	M66	SRS control module	MF81	Connection with FLOOR harness
M13	Cigarette lighter	M69	FE(Field-Effect) transistor	MF91	Connection with FLOOR harness
M14	Front accessory socket	M72	SMATRA (Immobilizer)	G17	Ground
M20	Auto light & Photo sensor (W/O ATM Shift Lock)	M73	Security indicator (W/O ATM Shift Lock)	G18	Ground
M21-1	A/C control module (Auto)	M74	Steering angle sensor (ESP)	G19	Ground
M21-2	A/C control module (Auto)	M76	Trip mode reset	G20	Ground
M22-1	A/C control module (Manual)	M78	Steering angle sensor (AGCS)	G21	Ground
M22-2	A/C control module (Manual)	M79	Dual Auto light & Photo sensor (With ATM Shift Lock)	G22	Ground
M23	Blower resister	M80	Dual security indicator (With ATM Shift Lock)	Z01	Diode (Fog lamp)
M25	Water temperature sensor	M81	Joint connector	<b>ROOF HARNESS</b>	
M27	Blower motor	M82	Joint connector	M100	Electronic chrome mirror
M28	Mode actuator (RHD)	M83	Joint connector	M102	Joint connector
M29	Mode actuator (LHD)	M84	Joint connector	M104	Sunroof switch
M30-1	Multifunction switch (LHD)	M86	Joint connector	M105	Left vanity lamp switch
M30-2	Multifunction switch (LHD)	M87	Joint connector	M106	Right vanity lamp switch
M30-3	Multifunction switch	M88	Head lamp washer switch	M107	Left vanity lamp
M31-1	Multifunction switch (RHD)	M91-1	Passenger compartment relay box	M108	Right vanity lamp
M31-2	Multifunction switch (RHD)	M91-2	Passenger compartment relay box	M110	Sunroof control module
M32	Evaporator sensor	M93	Seat belt reminder indicator	M111	Map lamp
M33-A	BCM	M95	Pre-Excitation resister (DSL)	M112	Room lamp
M33-B	BCM	M97	Driver temperature actuator (Dual FATC, LHD)	MF01	Connection with FLOOR harness
M33-C	BCM	M98	PTC heater (DSL)		
M34	Temperature actuator (Full Auto, RHD)	M99	Driver temperature actuator (Dual FATC, RHD)		
M35	Temperature actuator (Full Auto, LHD)	EM01	Connection with ENGINE ROOM harness		
M37	Intake actuator (LHD)	EM02	Connection with ENGINE ROOM harness		
M38	Active incar & humidity sensor	EM03	Connection with ENGINE ROOM harness		
M39	Key solenoid	EM11	Connection with ENGINE FRONT harness		
M40	Sport mode switch	EM21	Connection with ENGINE FRONT harness		
M41	Intake actuator (RHD)	EM31	Connection with ENGINE FRONT harness		
M42	Rheostat	EM41	Connection with ENGINE FRONT harness (RHD)		
M43	Flasher unit	I/P-A	Connection with PASSENGER COMPARTMENT JUNCTION BLOCK		
M44	Hazard switch	I/P-B	Connection with PASSENGER COMPARTMENT JUNCTION BLOCK		
M45	Door warning switch	I/P-C	Connection with PASSENGER COMPARTMENT JUNCTION BLOCK		
M46	Head lamp leveling switch	I/P-D	Connection with PASSENGER COMPARTMENT JUNCTION BLOCK		
M47	Horn switch	I/P-E	Connection with PASSENGER COMPARTMENT JUNCTION BLOCK		
M48	Glove box lamp	I/P-F	Connection with PASSENGER COMPARTMENT JUNCTION BLOCK (RHD)		
		I/P-G	Connection with PASSENGER COMPARTMENT JUNCTION BLOCK (RHD)		
		I/P-K	Connection with PASSENGER COMPARTMENT JUNCTION BLOCK (RHD)		



FLOOR HARNESS (1)

HL-3

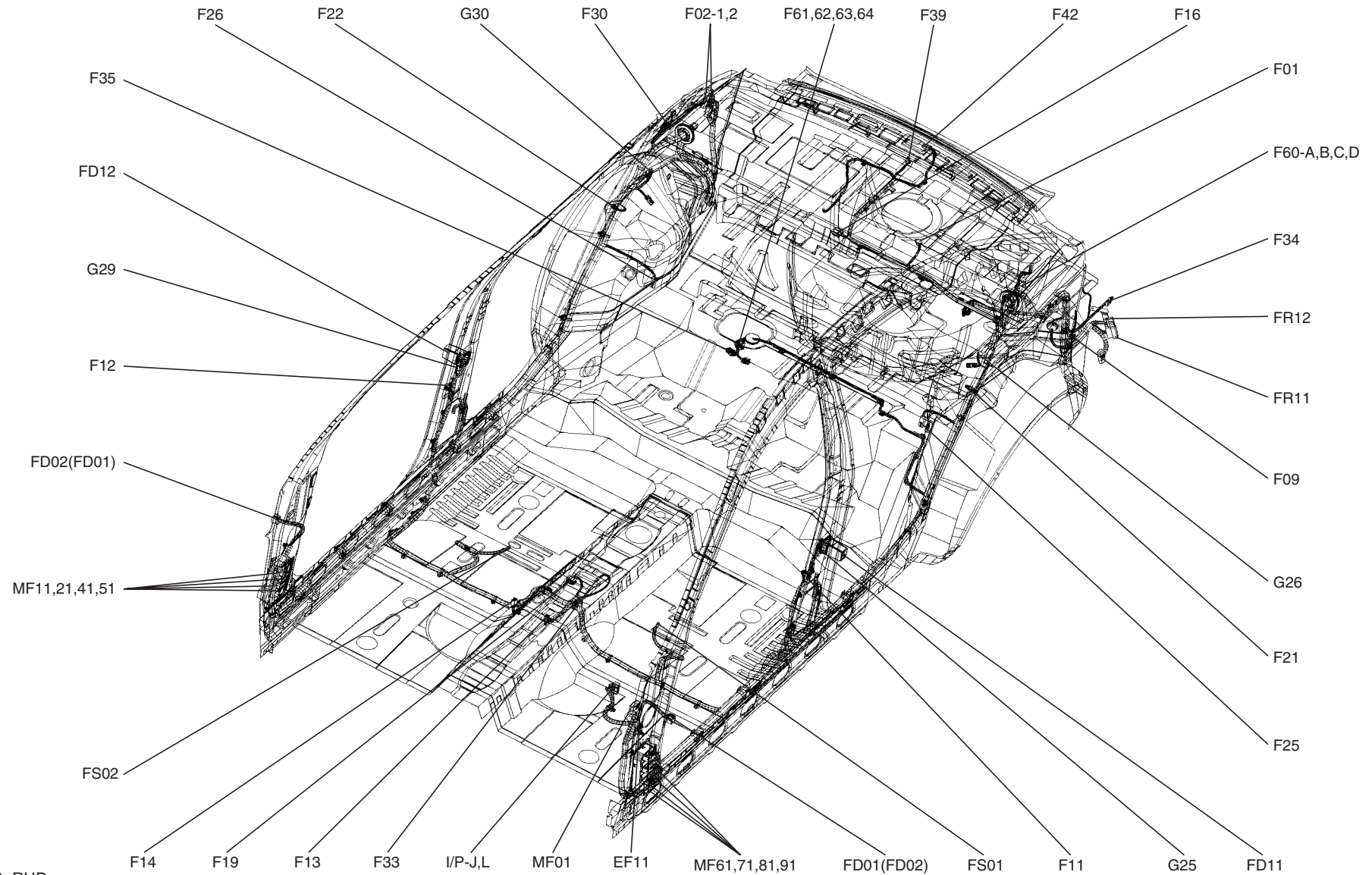

( ): RHD

## FLOOR HARNESS

### FLOOR HARNESS (2)

HL-4

F01	Woofers speaker	MF51	Connection with MAIN harness
F02-1	Audio amp	MF61	Connection with MAIN harness
F02-2	Audio amp	MF71	Connection with MAIN harness
F09	Back warning control module	MF81	Connection with MAIN harness
F11	Left front door switch	MF91	Connection with MAIN harness
F12	Right front door switch	G25	Ground
F13	Left front seat warmer switch	G26	Ground
F14	Right front seat warmer switch	G27	Ground
F16	Joint connector	G29	Ground
F19	Yaw rate sensor	G30	Ground
F21	Left rear door switch		
F22	Right rear door switch		
F25	Left rear wheel sensor		
F26	Right rear wheel sensor		
F30	Glass antenna module		
F33	Parking brake switch		
F34	Fuel filler actuator		
F35	Fuel sender & Fuel pump motor		
F39	High mounted stop lamp		
F40	Rear power outlet		
F42	Trunk room lamp		
F60-A	Active geometry control suspension (AGCS) module		
F60-B	Active geometry control suspension (AGCS) module		
F60-C	Active geometry control suspension (AGCS) module		
F60-D	Active geometry control suspension (AGCS) module		
F61	Right encoder/Limit switch		
F62	Left encoder/Limit switch		
F63	Right active geometry control suspension (AGCS) motor		
F64	Left active geometry control suspension (AGCS) motor		
EF11	Connection with FRONT harness		
FD01	Connection with DRIVER DOOR harness		
FD02	Connection with PASSENGER DOOR harness		
FD11	Connection with LH REAR DOOR harness		
FD12	Connection with RH REAR DOOR harness		
FR11	Connection with TRUNK ROOM harness		
FR12	Connection with BACK WARNING EXT. harness		
FS01	Connection with FRONT POWER SEAT harness (Driver)		
FS02	Connection with FRONT POWER SEAT harness (Passenger)		
I/P-J	Connection with PASSENGER COMPARTMENT JUNCTION BLOCK		
I/P-L	Connection with PASSENGER COMPARTMENT JUNCTION BLOCK		
MF01	Connection with ROOF harness		
MF11	Connection with MAIN harness		
MF21	Connection with MAIN harness		
MF41	Connection with MAIN harness		

ENGINE HARNESS (1)

HL-5

ENGINE FRONT HARNESS

ENGINE ROOM HARNESS

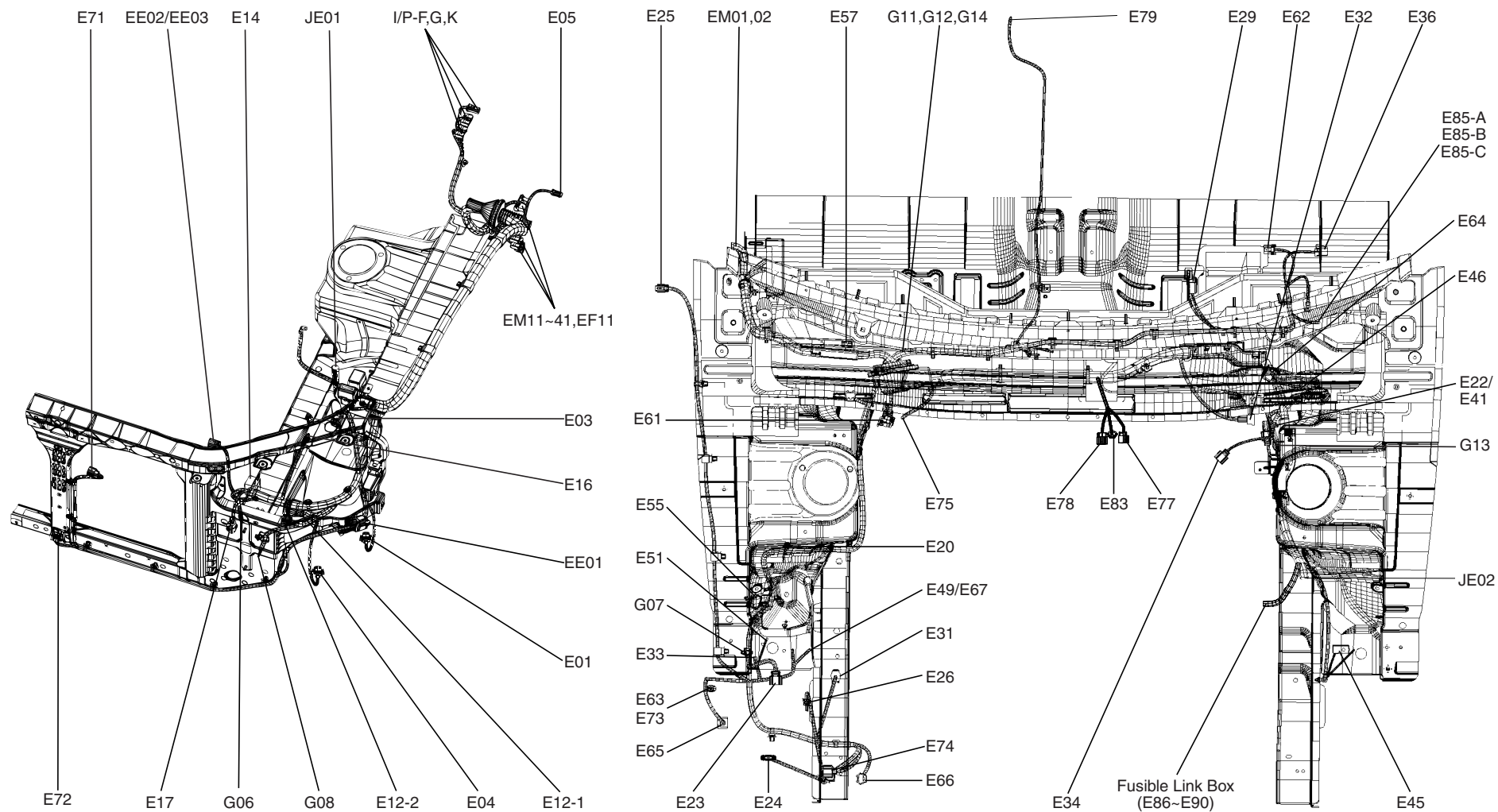

## ENGINE HARNESS

### ENGINE HARNESS (2)

HL-6

#### ENGINE FRONT HARNESS

E01	Left horn
E03	Left head lamp
E04	Left front fog lamp
E05	Left side repeater lamp
E12-1	Cooling fan assey #1
E12-2	Cooling fan assey #2
E14	Cooling fan relay
E16	Left head lamp leveling actuator
E17	Driver front impact sensor
EE01	Connection with ENGINE FRONT END MODULE harness
EE02	Connection with BATTERY harness (GSL)
EE03	Connection with BATTERY harness (DSL)
EF11	Connection with FLOOR harness
EM11	Connection with MAIN harness
EM21	Connection with MAIN harness
EM31	Connection with MAIN harness
EM41	Connection with MAIN harness (RHD)
I/P-F	Connection with PASSENGER COMPARTMENT JUNCTION BLOCK (LHD)
I/P-G	Connection with PASSENGER COMPARTMENT JUNCTION BLOCK (LHD)
I/P-K	Connection with PASSENGER COMPARTMENT JUNCTION BLOCK (LHD)
JE01	Connection with ENGINE COMPARTMENT JUNCTION BLOCK
G06	Ground
G08	Ground

#### ENGINE FRONT END MODULE HARNESS

E71	Right horn
E72	AQS & Ambient sensor
EE01	Connection with ENGINE FRONT harness

#### BATTERY HARNESS

E10	Start solenoid (GSL)
E11	Start solenoid (DSL)
EE02	Connection with ENGINE FRONT harness (GSL)
EE03	Connection with ENGINE FRONT harness (DSL)

#### ENGINE ROOM HARNESS

E20	Multipurpose check connector	EM01	Connection with MAIN harness
E22	ABS control module	EM02	Connection with MAIN harness
E23	Right head lamp	EM03	Connection with MAIN harness
E24	Right front fog lamp	JE02	Connection with ENGINE COMPARTMENT JUNCTION BLOCK
E25	Right side repeater lamp	G07	Ground
E26	Right head lamp leveling actuator	G11	Ground
E29	Accel position sensor	G12	Ground
E31	A/C pressure transducer	G13	Ground
E32	Brake oil level sensor	G14	Ground
E33	Burglar horn		
E34	Back-up lamp switch		
E36	Cruise clutch pedal position switch		
E41	ESP control module		
E45	Left front wheel sensor		
E46	Windshield defogger		
E49	Right front wheel sensor		
E51	Hood switch		
E55	Joint connector		
E57	Joint connector		
E61	Power steering pressure sensor (LHD)		
E62	Stop lamp switch		
E63	Washer motor		
E64	Wiper motor		
E65	Washer level sensor		
E66	Passenger front impact sensor		
E67	Front wheel sensor		
E73	Head lamp washer motor		
E74	Head lamp washer relay		
E75	VGT actuator (DSL)		
E77	Fuel filter heater (DSL)		
E78	Fuel filter heater switch (DSL)		
E79	Exhaust gas temperature sensor #2 (DSL)		
E82	Differential pressure sensor (DSL)		
E83	Fuel filter warning switch (DSL)		
E85-A	TCM (DSL)		
E85-B	TCM (DSL)		
E85-C	TCM (DSL)		
E86	PTC heater relay #1 (DSL)		
E87	PTC heater relay #2 (DSL)		
E88	PTC heater relay #3 (DSL)		
E89	Fuel filter heater relay (DSL)		
E90	Glow plug relay (DSL)		
EC11	Connection with CONTROL harness (DSL)		

AIR BAG HARNESS (1)

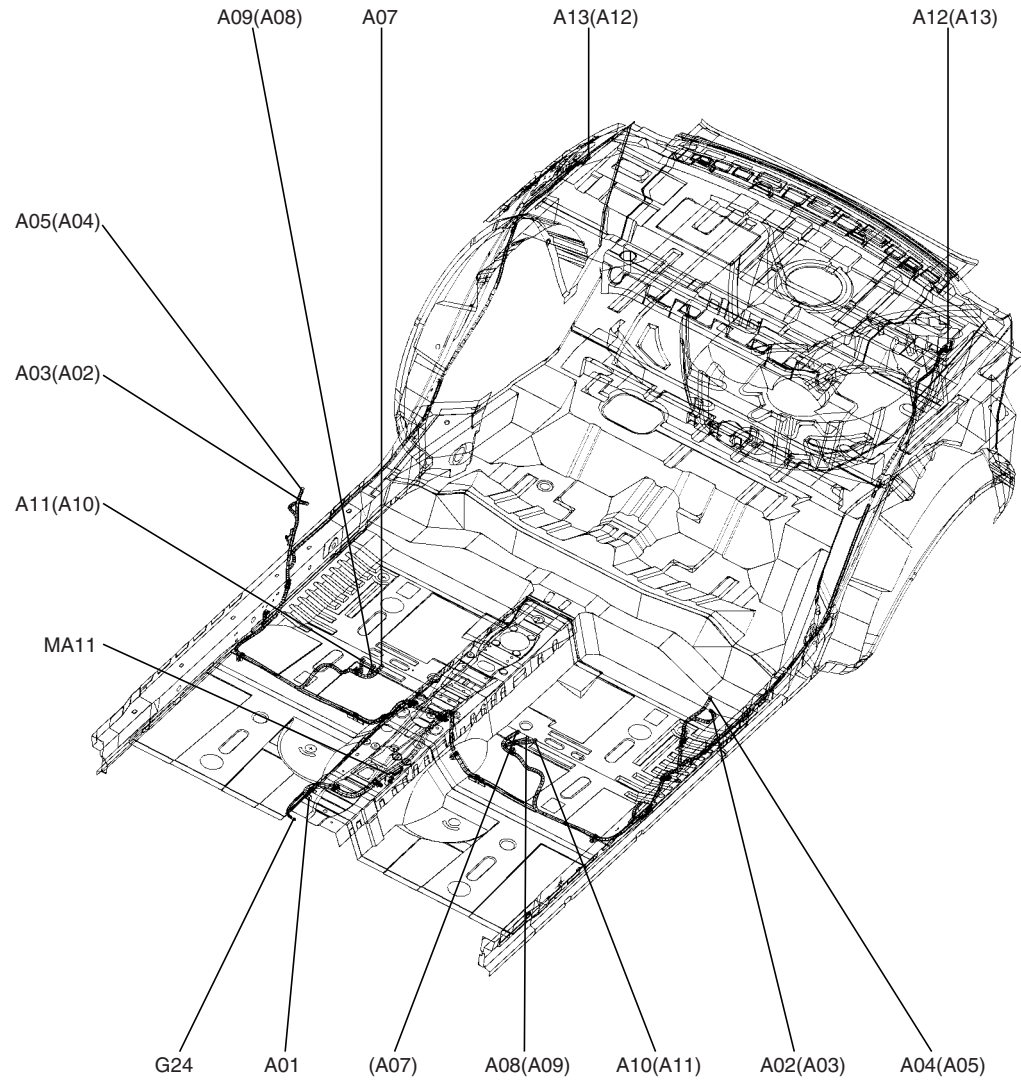

AIR BAG HARNESS

- A01 SRS control module
- A02 Driver seat belt pretensioner
- A03 Passenger seat belt pretensioner
- A04 Driver side impact sensor
- A05 Passenger side impact sensor
- A07 Seat belt reminder mat
- A08 Driver side air bag
- A09 Passenger side air bag
- A10 Driver seat buckle switch
- A11 Passenger seat buckle switch
- A12 Driver curtain air bag
- A13 Passenger curtain air bag
- MA11 Connection with MAIN harness
- G24 Ground

( ): RHD

CONTROL HARNESS (1)

GSL 2.0L/2.4L

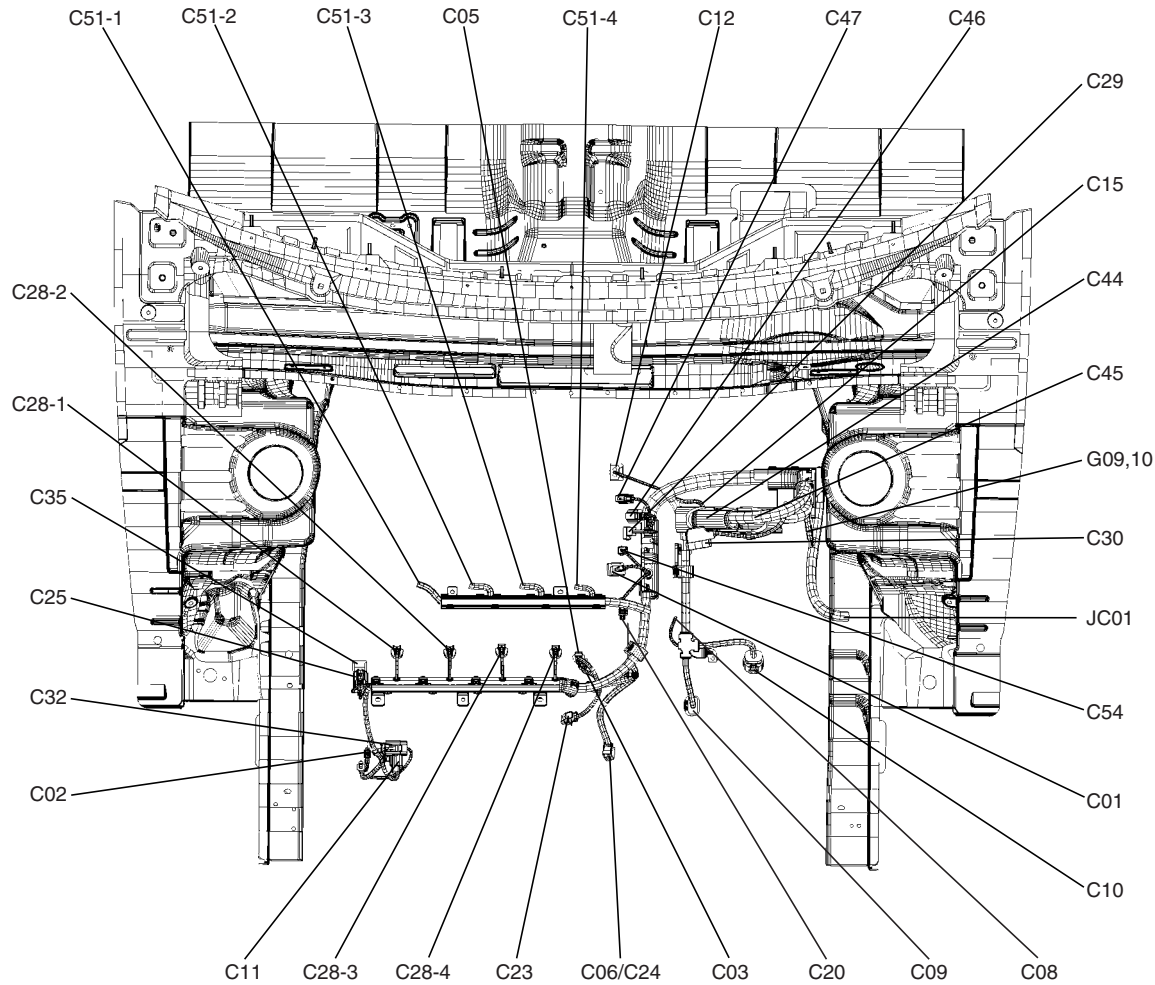

CONTROL HARNESS (GSL 2.0L/2.4L)

- C01 Engine coolant temperature sensor & Sender
- C02 A/C compressor
- C03 Knock sensor
- C05 Camshaft position sensor
- C06 ETC (Electronic throttle control) (2.4L)
- C08 Pulse generator 'A'
- C09 Transaxle range switch
- C10 ATM solenoid
- C11 Oil pressure switch
- C12 Vehicle speed sensor
- C15 Pulse generator 'B'
- C20 Canister purge solenoid valve
- C23 Idle speed control actuator (2.0L)
- C24 Throttle position sensor (2.0L)
- C25 Oil control valve
- C28-1 Injector #1
- C28-2 Injector #2
- C28-3 Injector #3
- C28-4 injector #4
- C29 Crankshaft position sensor
- C30 Mass air flow sensor
- C32 Generator
- C35 Oil temperature sensor
- C44 PCM
- C45 TCM
- C46 Oxygen sensor (UP)
- C47 Oxygen sensor (DOWN)
- C51-1 Ignition coil #1
- C51-2 Ignition coil #2
- C51-3 Ignition coil #3
- C51-4 Ignition coil #4
- C54 Condenser
- JC01 Connection with ENGINE COMPARTMENT JUNCTION BLOCK
- G09 Ground
- G10 Ground

# CONTROL HARNESS

## CONTROL HARNESS (2)

HL-9

### GSL 3.3L

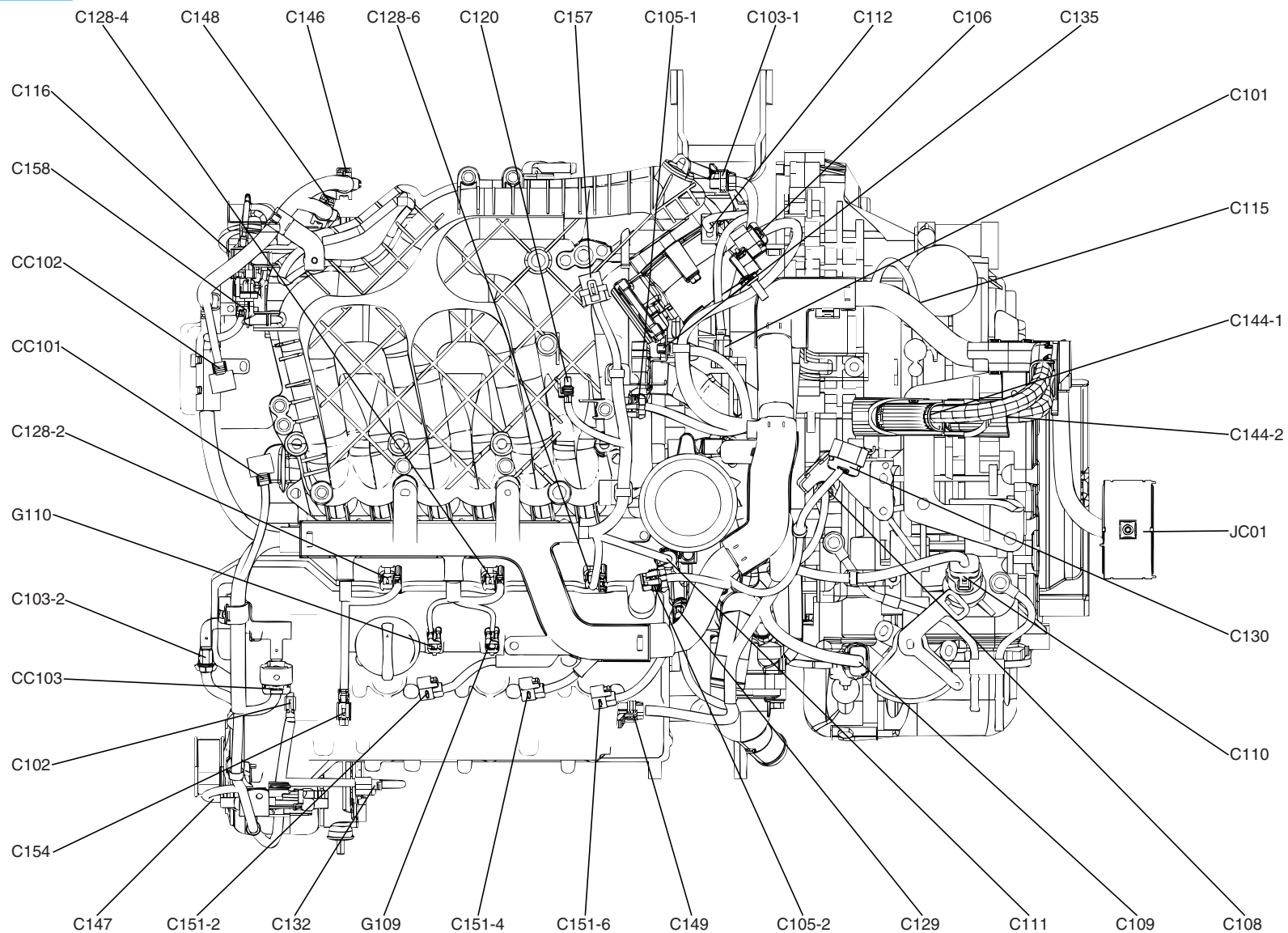

## CONTROL HARNESS

### CONTROL HARNESS (3)

HL-10

#### CONTROL HARNESS (GSL 3.3L)

C101	Engine coolant temperature sensor & Sender
C102	A/C compressor
C103-1	Knock sensor #1
C103-2	Knock sensor #2
C105-1	Camshaft position sensor #1
C105-2	Camshaft position sensor #2
C106	ETS motor & Throttle position sensor
C108	Pulse generator 'A'
C109	Transaxle range switch
C110	ATM solenoid
C111	Oil pressure switch
C112	Vehicle speed sensor
C115	Pulse generator 'B'
C116	Power steering pressure sensor (RHD)
C120	Canister purge solenoid valve
C128-2	Injector #2
C128-4	Injector #4
C128-6	Injector #6
C129	Crankshaft position sensor
C130	Mass air flow sensor
C132	Generator
C135	Oil temperature sensor
C144-1	PCM
C144-2	PCM
C146	Oxygen sensor (B1/S1)
C147	Oxygen sensor (B2/S1)
C148	Oxygen sensor (B1/S2)
C149	Oxygen sensor (B2/S2)
C151-2	Ignition coil #2
C151-4	Ignition coil #4
C151-6	Ignition coil #6
C154	Condenser
C157	Manifold absolute pressure sensor
C158	Variable intake manifold valve
CC101	Connection with IGNITION COIL harness
CC102	Connection with INJECTOR harness
CC103	Connection with OIL CONTROL VALVE harness
JC01	Connection with ENGINE COMPARTMENT JUNCTION BLOCK
G109	Ground
G110	Ground

#### INJECTOR HARNESS

C128-1	Injector #1
C128-3	Injector #3
C128-5	Injector #5
CC102	Connection with CONTROL harness

#### IGNITION COIL HARNESS

C151-1	Ignition coil #1
C151-3	Ignition coil #3
C151-5	Ignition coil #5
C153	Condenser
CC101	Connection with CONTROL harness

#### OIL CONTROL VALVE HARNESS

C161-1	Oil control valve #1
C161-2	Oil control valve #2
CC103	Connection with CONTROL harness



# CONTROL HARNESS

## CONTROL HARNESS (4)

HL-11

### DIESEL

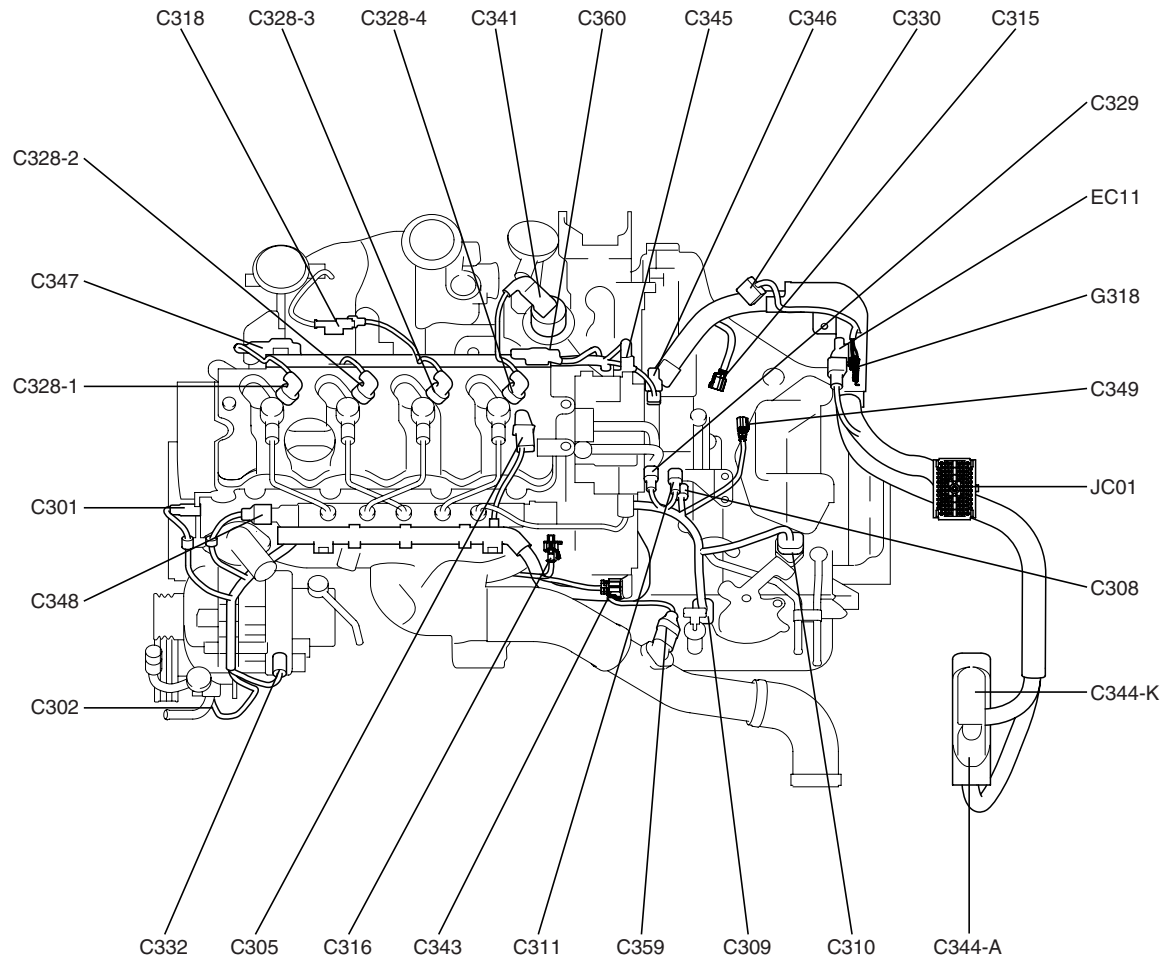

### CONTROL HARNESS (DIESEL)

- C301 Engine coolant temperature sensor & Sender
- C302 A/C compressor
- C305 Camshaft position sensor
- C308 Pulse generator 'A'
- C309 Transaxle range switch
- C310 ATM solenoid
- C311 Oil pressure switch
- C312 Vehicle speed sensor
- C315 Pulse generator 'B'
- C316 Fuel pressure regulating valve
- C318 Exhaust gas temperature sensor #1
- C328-1 Injector #1
- C328-2 Injector #2
- C328-3 Injector #3
- C328-4 Injector #4
- C329 Crankshaft position sensor
- C330 Air flow sensor
- C332 Generator
- C341 EGR actuator
- C342 Electrical throttle control actuator
- C343 Variable swirl control actuator
- C344-A ECM
- C344-K ECM
- C345 Fuel metering unit
- C346 Fuel temperature sensor
- C347 Lambda sensor
- C348 Rail pressure sensor
- C349 Neutral switch
- C359 Boost pressure sensor
- C360 Glow plug
- EC11 Connection with ENGINE ROOM harness
- JC01 Connection with ENGINE COMPARTMENT JUNCTION BLOCK
- G318 Ground

DOOR HARNESS (1)

HL-12

FRONT DOOR

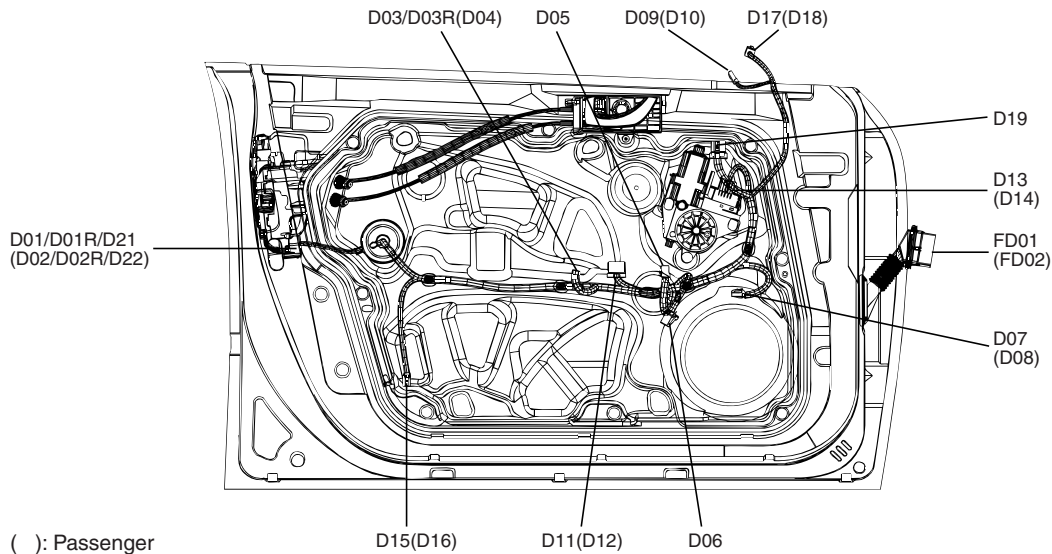

( ): Passenger

REAR DOOR

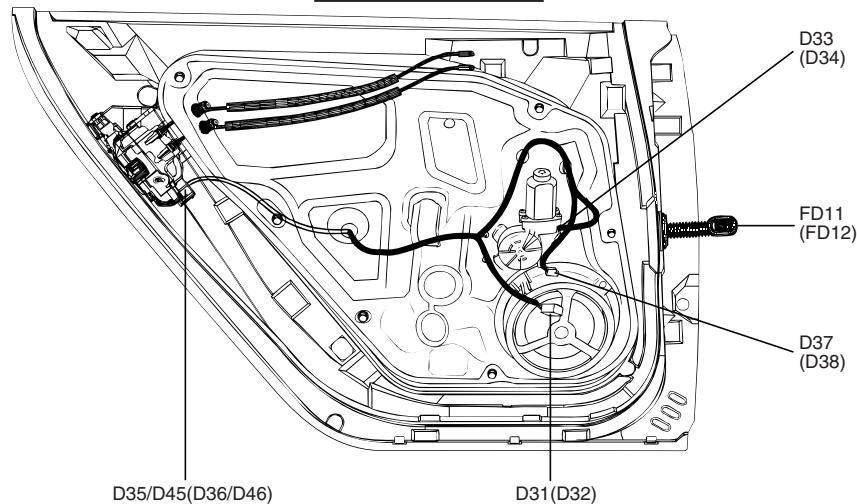

( ): Right

DRIVER DOOR HARNESS

- D01 Driver door lock actuator
- D01R Driver door lock actuator (RHD)
- D03 Power window main switch
- D03R Power window main switch (RHD)
- D05 Power outside mirror & mirror folding switch
- D06 Fuel filler door & Trunk lid switch
- D07 Driver door speaker
- D09 Driver tweeter speaker
- D11 Joint connector
- D13 Safty window module
- D15 Driver door lamp
- D17 Driver outside mirror & mirror folding motor
- D19 Power outside mirror folding module
- D21 Driver door lock actuator (Dead Lock, RHD)
- FD01 Connection with FLOOR harness

PASSENGER DOOR HARNESS

- D02 Passenger door lock actuator
- D02R Passenger door lock actuator (RHD)
- D04 Passenger power window switch
- D08 Passenger door speaker
- D10 Passenger tweeter speaker
- D12 Joint connector
- D14 Passenger power window motor
- D16 Passenger door lamp
- D18 Passenger outside mirror & mirror folding motor
- D22 Passenger door lock actuator (Dead Lock, RHD)
- FD02 Connection with FLOOR harness

LH REAR DOOR HARNESS

- D31 Left rear power window switch
- D33 Left rear power window motor
- D35 Left rear door lock actuator
- D37 Left rear door speaker
- D45 Left rear door lock actuator (Dead Lock, RHD)
- FD11 Connection with FLOOR harness

RH REAR DOOR HARNESS

- D32 Right rear power window switch
- D34 Right rear power window motor
- D36 Right rear door lock actuator
- D38 Right rear door speaker
- D46 Right rear door lock actuator (Dead Lock, RHD)
- FD12 Connection with FLOOR harness

REAR HARNESS (1)

TRUNK LID

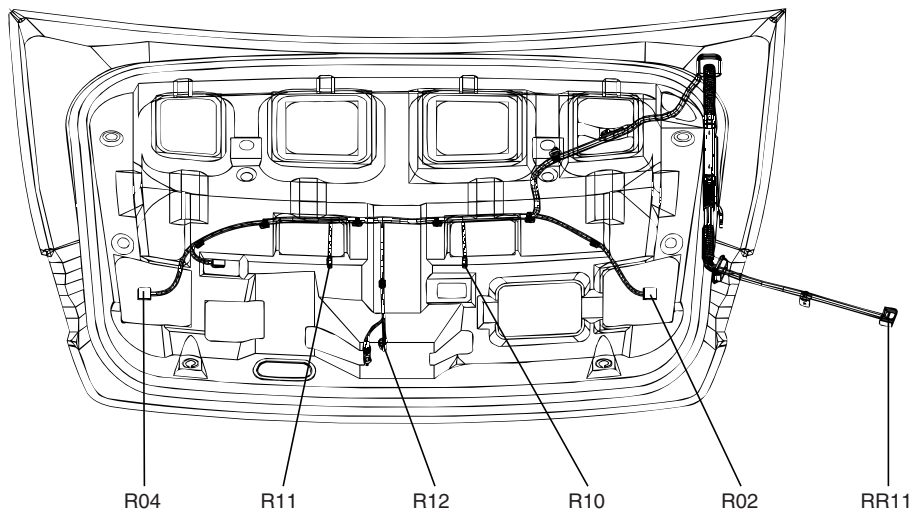

TRUNK LID HARNESS

- R02 Left rear combination lamp (IN)
- R04 Right rear combination lamp (IN)
- R10 Left license lamp
- R11 Right license lamp
- R12 Trunk lid motor
- RR11 Connection with TRUNK ROOM harness

BACK WARNING EXT. HARNESS

- R15 Left back warning sensor
- R16 Center back warning sensor
- R17 Right back warning sensor
- FR12 Connection with FLOOR harness

TRUNK ROOM HARNESS

- R01 Left rear combination lamp (OUT)
- R03 Right rear combination lamp (OUT)
- RR11 Connection with TRUNK LID harness
- FR11 Connection with FLOOR harness
- G32 Ground

TRUNK ROOM

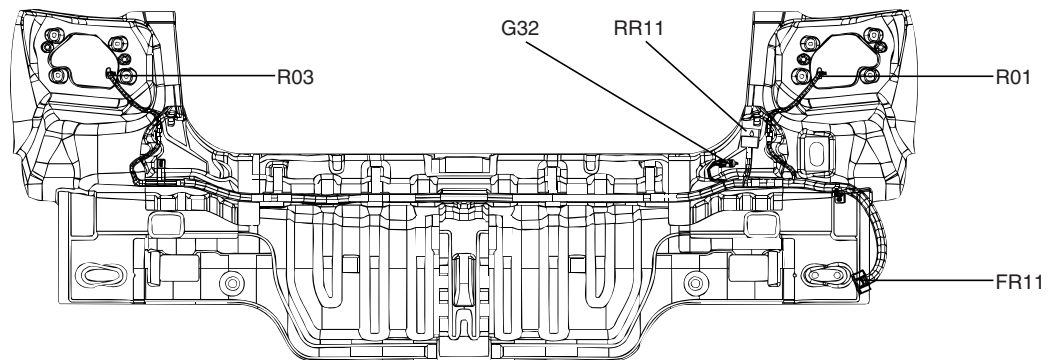

SEAT HARNESS (1)

**DRIVER**

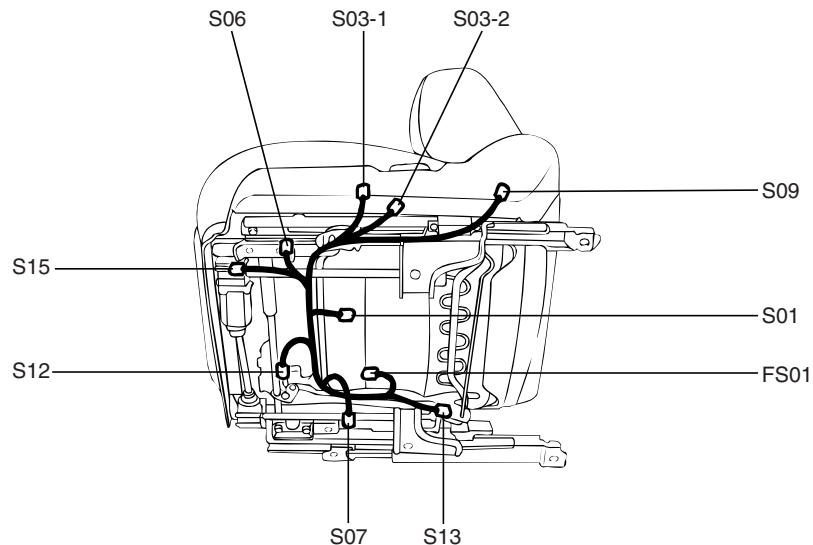

**FRONT POWER SEAT HARNESS**

- S01 Left front seat warmer
- S02 Right front seat warmer
- S03-1 Driver power seat manual switch
- S03-2 Driver power seat manual switch
- S04 Passenger power seat manual switch
- S06 Front height adjuster motor
- S07 Driver slide limit switch
- S08 Passenger slide limit switch
- S09 Driver reclining limit switch
- S10 Passenger reclining limit switch
- S12 Rear height adjuster motor
- S13 Driver reclining adjuster motor
- S14 Passenger reclining adjuster motor
- S15 Driver slide motor
- S16 Passenger slide motor
- FS01 Connection with FLOOR harness (Driver)
- FS02 Connection with FLOOR harness (Passenger)

**PASSENGER**

