

INTRODUCTION (1)

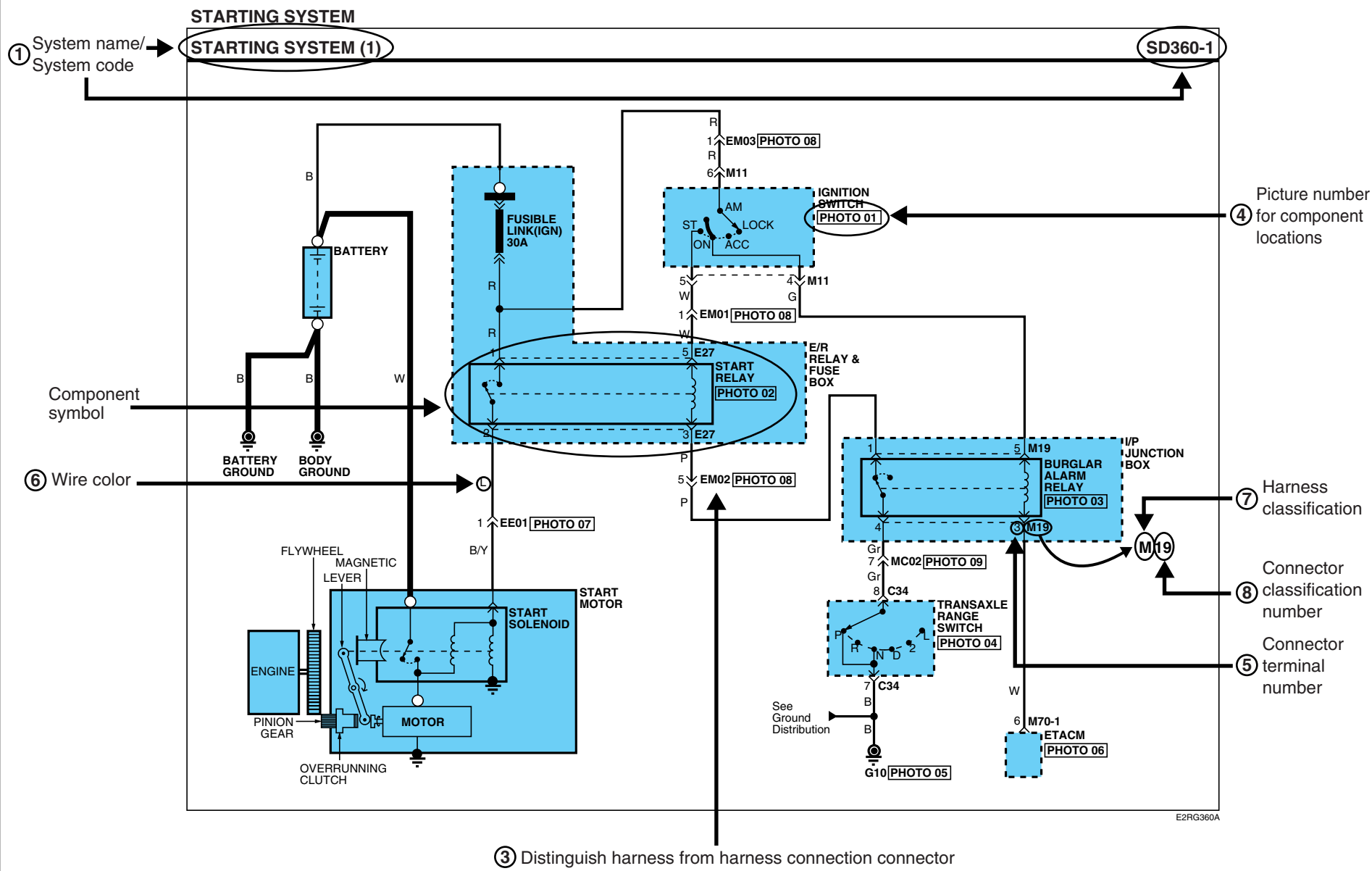

# INTRODUCTION

## INTRODUCTION (2)

GI-2

### STARTING SYSTEM

#### STARTING SYSTEM (2)

SD360-2

② Connector configurations (components)

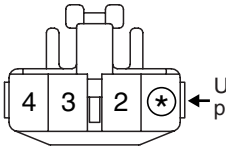
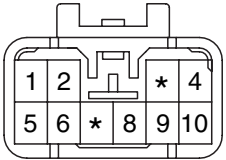
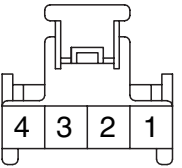
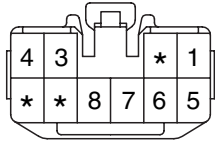
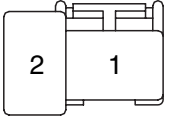
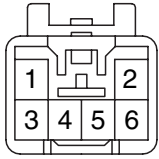
<p><b>M05</b></p>  <p>KET_090II_04F_W</p>	<p><b>M06</b></p>  <p>KET_090II_10M_W</p>	<p><b>M11</b></p>  <p>KUM_AR_04F_W</p>	<p><b>M13</b></p>  <p>KET_090II_10F_W</p>
<p><b>M67</b></p>  <p>AMP_PLM2_02F_B</p>	<p><b>M81</b></p>  <p>KET_090II_06M_W</p>	<p><b>BLANK</b></p>	<p><b>BLANK</b></p>

E2RG360B

Explanation of connector code

### M05

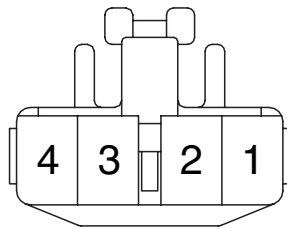

KET\_090II\_04F\_W

a b c d e

a : Connector manufacturer

b : Terminal series number

c : The number of connector terminals

d : Connector distinguishing

- Female Pin : F
- Male Pin : M

e : Connector color abbreviations

- B (Black)
- Br (Brown)
- G (Green)
- Gr (Gray)
- L (Blue)
- R (Red)
- W (White)
- Y (Yellow)

① Pages by system/ Name of Schematic diagram

- Each page is consisted of circuits by system. This schematic diagram includes the path of electricity flow, connection condition for each switch, and the function of other relevant circuits at once. It is applicable to real service work.
- It is very important to understand relevant circuits exactly before troubleshooting diagnosis.
- Circuits by system depends upon part number and are indicated on schematic diagram index.

② Connector configuration (components)

- The connector figure of components in the schematic diagram by system is indicated on the last page of schematic diagram.
- It shows the front of the connector on the harness side when not to the harness connector. The terminal number on each connector can be obtained by following the pattern used in ⑤ connector view and numbering order. Unused terminals are marked with an asterisk (\*).

③ Connector configurations (connection between harnesses)

- When connecting the harness with connector between harnesses, it shows female and male connectors and indicates them on the connector configurations group.

EM02

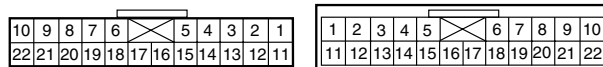

④ Component locations

- To find the components easily, a component locations diagram is indicated with "PHOTO NO" on the lower portion of the component name.
- To make it easy to distinguish connectors, the connector in the picture is indicated being installed in the vehicle.

PHOTO 03

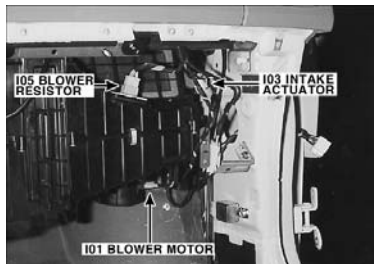

⑤ CONNECTOR VIEW AND NUMBERING ORDER

Female	Male	Remarks
		<p>It is not the shape of the connector housing, but the connector pin that distinguishes between male or female connectors. When numbering female and male connectors, refer to the numbering order in the following table. Some connectors may not follow this method of numbering order. For individual detailed numbering, refer to the CONNECTOR CONFIGURATIONS.</p>
		<p>Numbered in order from upper right to lower left</p> <p>Numbered in order from upper left to lower right</p>

NOTE

UNLESS OTHERWISE STATED, ALL CONNECTOR VIEWS ARE FROM THE TERMINAL SIDE OF THE CONNECTOR.

# INTRODUCTION

## INTRODUCTION (4)

GI-4

### ⑥ WIRE COLOR ABBREVIATIONS

The following abbreviations are used to identify wire colors in the circuit schematics.

Symbol	Color of wire	Symbol	Color of wire
B	Black	O	Orange
Br	Brown	P	Pink
G	Green	R	Red
Gr	Gray	W	White
L	Blue	Y	Yellow
Lg	Light Green	Pp	Purple
T	Tan	LI	Light Blue

\* **(Y)**/**(B)**: Black stripe with yellow ground (2 colors)

↑                      ↑  
the color of        the color of  
background        stripe

### ⑦ HARNESS CLASSIFICATION

Electrical wiring connectors are classified according to the wiring parts in the Harness Layouts.

Symbol	Harness name	Location
A	Air bag harness	Floor
C	Control, Injector, Ignition harness	Engine compartment
D	Door harness	Door
E	Engine front, Engine front, Battery, Engine front end harness	Engine compartment Passenger compartment
F	Floor, Console EXT. harness	Floor
M	Main harness	Passenger compartment
R	Trunk lid, Trunk room harness Back warning, Roof harness	Trunk, Rear bumper, Roof
S	Seat harness	Seat

\* It depends on vehicles, it is necessary to check the harness name symbol on the harness layouts for detailed symbol.

### ⑧ CONNECTOR IDENTIFICATION

A connector identification symbol consists of a wiring harness location classification symbol corresponding to a wiring harness location and number corresponding to the connector. These connector locations can be found in the HARNESS LAYOUTS.

For example:

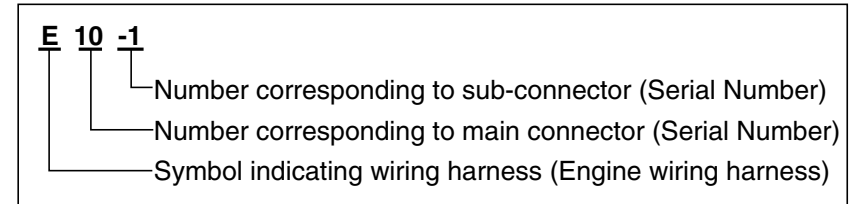

#### NOTE

**Connectors which connect each wiring harness are represented by the following symbols.**

For example:

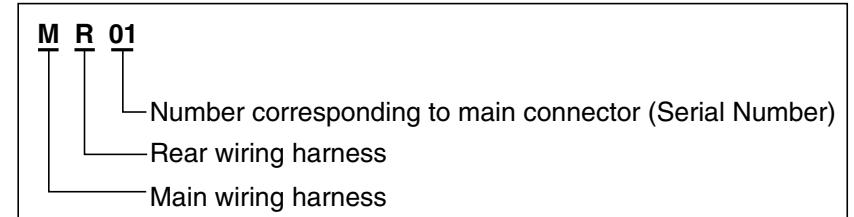

### JUNCTION BLOCK IDENTIFICATION

A junction block identification symbol consists of a wiring harness location classification symbol corresponding to a wiring harness location and number corresponding to the connector in the junction block.

For example:

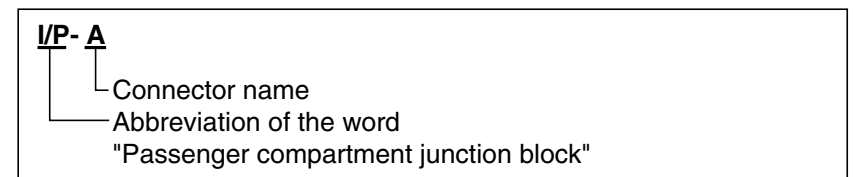

**HARNESS LAYOUTS**

Harness layouts show the routing of the major wiring harnesses, the in-line connectors and the splices between the major harnesses. These layouts will make electrical troubleshooting easier.

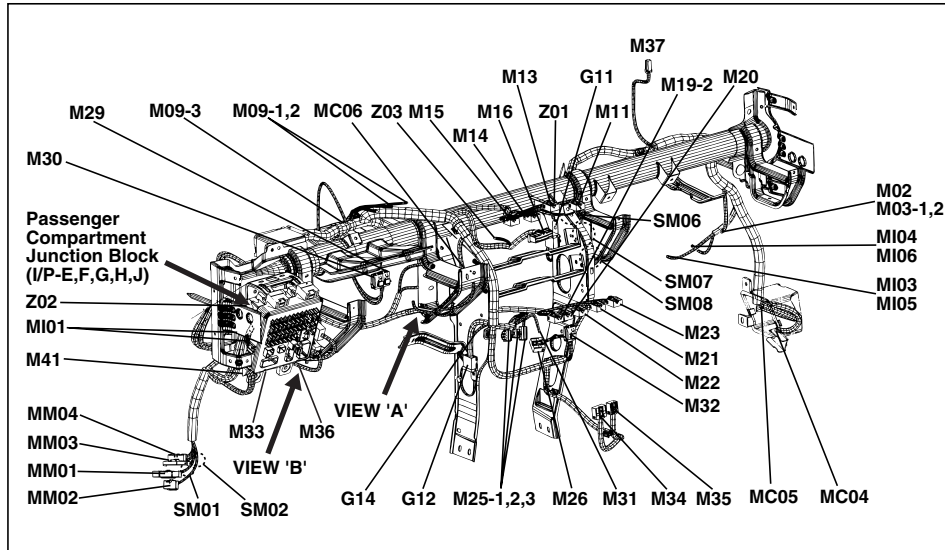









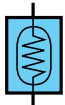
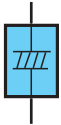

SYMBOLS (1)

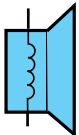
Section	Symbol	Meaning	Section	Symbol	Meaning	Section	Symbol	Meaning	Section	Symbol	Meaning
C O M P O N E N T		A solid line means the entire component is shown.	C O N N E C T O R		Shows the name of each connector on the component location index for reference.	S H I E L D W I R E		This represents RFI (Radio Frequency Interference) Shielding around a wire. The shielding is always connected to ground.	L A M P		Double filament
		A broken line indicates only part of the component is shown.			Indicates the number of corresponding terminal. (Only relevant terminal on the corresponding schematic diagram).			Single filament			
		This means the connector connects directly to the component.	W I R E		A wavy line means the wire is broken but is to be continued.	J O I N T C O N N E C T O R		This is a connector showing the joining wires.	D I O D E		Diode
		This indicates the connector connects to a lead (pigtail), wired directly to the component.			Wire insulation is yellow with a red strip.			Led diode			
		This indicates a screw terminal on the component.	S P L I C E S		Current path is continued on the same page or another page. The arrow shows the direction of current flow. You should look for the "A" in the marked position.	S O W B L O W		Power supplied at all times. Name Capacity	T R		NPN
		This ground symbol (dot and 3 lines overlapping the component) means the housing of the component is attached to a metal part of the vehicle.			A wire connects to another circuit. The wire is shown again on that circuit which the arrow is pointing.			PNP			
		This indicates a screw terminal on the component.	G R O U N D		Wire choices for options or different models are labeled and shown with a "choice" bracket like this.	F U S E		This means power is supplied with the ignition on position. This means the short bar connects to other fuses. Identification Current rating	G E N E R A L C O M P O N E N T S Y M B O L		These switches move together: a dashed line shows a mechanical connection between them.
		The name of the component appears next to its upper right corner.			Splices are numbered and shown as a dot with circle. The exact location and connection of these splices may vary among vehicles.			This means power is supplied with the ignition on position.			Switch (1 contact point)
	Shows the number of pictures for component location.			This symbol means the end of the wire is attached to a metal part of the vehicle.			Control battery power at all times			Heater	

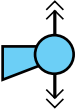
# SYMBOLS

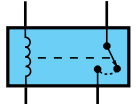
## SYMBOLS (2)

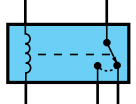
GI-7

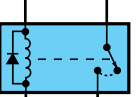
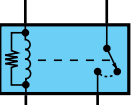
Section	Symbol	Meaning	Section	Symbol	Meaning
GENERAL COMPONENTS SYMBOL		Sensor	GENERAL COMPONENTS SYMBOL		Condenser
		Sender			Speaker
		Injector			Horn, Buzzer, Siren, Chime Bell
		Solenoid	RELAY		Normally open contact
		Motor			This is a relay shown with no current flowing through its coil. When a current flows through coil, contact will toggle.
	Battery			Diode interior relay	
				Resistance interior relay	

## TROUBLESHOOTING INSTRUCTIONS (1)

GI-8

## TROUBLESHOOTING INSTRUCTIONS

## TROUBLESHOOTING PROCEDURES

The following five-step troubleshooting procedure is recommended.

**1. Verify the customer's complaints**

Turn on all the components in the problem circuit to check the accuracy of the customer's complaints. Note the symptoms.

Do not begin disassembly or testing until you have narrowed down the probable causes.

**2. Read and analyze the schematic diagram**

Locate the schematic for the problem circuit. Determine how the circuit is supposed to work by tracing the current paths from the power source through the system components to ground. If you do not understand how the circuit should work, read the circuit operation text. Also check other circuits that share with the problem circuit. The name of circuits that share the same fuse, ground, or switch, for example, are referred to on each diagram. Try to operate any shared circuits you did not check in step 1. If the shared circuit works, the shared wiring is okay, and the cause must be within the wiring used only by the problem circuit.

If several circuits fail at the same time, the fuse or ground is a likely cause.

**3. Inspect the circuit/ component with the problem isolated**

Make a circuit test to check the diagnosis you made in step 2. Remember that a logical, simple procedure is the key to efficient troubleshooting. Narrow down the probable causes using the troubleshooting hints and system diagnosis charts.

Test for the most likely cause of failure first.

Try to make tests at points that are easily accessible.

**4. Repair the problem**

Once the problem is found, make the necessary repairs.

**5. Make sure the circuit works**

Repeat the system check to be sure you have repaired the problem. If the problem was a blown fuse, be sure to test all of the circuits on that fuse.

## TROUBLESHOOTING EQUIPMENT

**VOLTMETER AND TEST LAMP**

Use a test lamp or a voltmeter on circuits without solidstate units and use a test lamp to check for voltage. A test lamp is made up of a 12-volt light bulb with a pair of leads attached. After grounding one lead, touch the other lead to various points along the circuit where voltage should be present.

When the bulb goes on, there is voltage at the point being tested.

**CAUTION**

**A number of circuits include solid-state modules, such as the Engine Control Module(ECM), used with computer command control injection. Voltage in these circuits should be tested only with a 10-megaohm or higher impedance digital multimeter. Never use a test lamp on circuits that contain solid state modules. Damage to the modules may result.**

A voltmeter can be used in place of a test lamp. While a test lamp shows whether the voltage is present or not, a voltmeter indicates how much voltage is present.

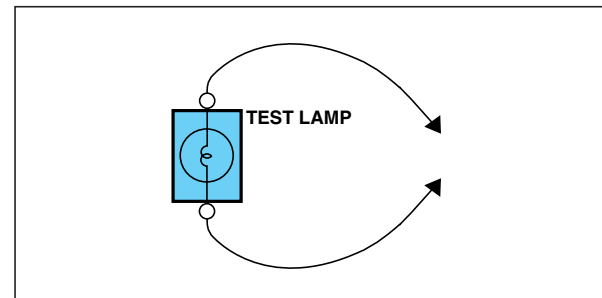
**SELF-POWERED TEST LAMP AND OHMMETER**

Use a self-powered test lamp or an ohmmeter to check for continuity.

The ohmmeter shows how much resistance there is between two points along a circuit. Low resistance means good continuity.



## TROUBLESHOOTING INSTRUCTIONS

### TROUBLESHOOTING INSTRUCTIONS (2)

GI-9

#### CAUTION

**Never use a self-powered test lamp on circuits that contain solid state modules. Damage to these modules may result.**

An ohmmeter can be used in place of a self-powered test lamp. The ohmmeter shows how much resistance there is between two points along a circuit. Low resistance means good continuity.

Circuits which include any solid-state devices should be tested only with a 10-megaohm or higher impedance digital multimeter. When measuring resistance with a digital multimeter, the battery negative terminal should be disconnected. Otherwise, there may be incorrect readings. Diodes and solid-state devices in a circuit can make an ohmmeter give a false reading. To find out if a component is affecting a measurement, take one reading, reverse the leads and take a second reading. If different the solid-state device is affecting the measurement.

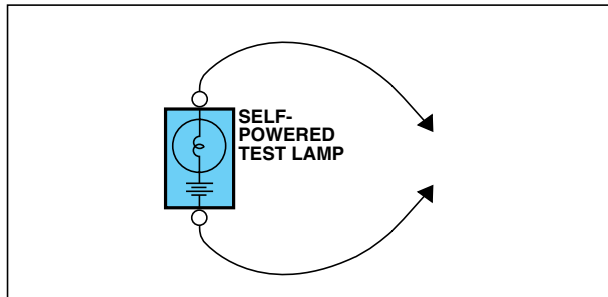

#### JUMPER WIRE WITH FUSE

Use a jumper wire with a fuse to by-pass an open circuit.

A jumper wire is made up of an in-line fuse holder connected to a set of test leads. This tool is available with small clamp connectors providing adaption to most connectors without damage.

#### CAUTION

**Do not use a fuse with a higher rating than the specified fuse that protects the circuit being tested. Do not use this tool in any situation to substitute an input or output at the solid-state control module, such as ECM, TCM, etc.**

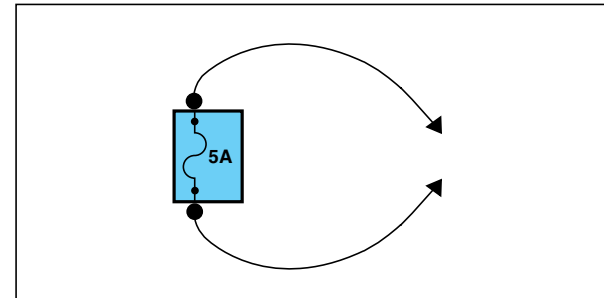

#### SHORT FINDER

A short finder is available to locate a short to ground. The short finder creates a pulsing magnetic field in the shorted circuit and shows you the location of the short through body trim or sheet metal.

#### TROUBLESHOOTING TEST

##### 1. TESTING FOR VOLTAGE

This test measures voltage in a circuit. When testing for voltage at a connector, you do not have to separate the two halves of the connector. Instead, probe the connector from the back(backprobe). Always check both sides of the connector because dirt and corrosion between its contact surfaces can cause electrical problems.

- A. Connect one lead of a test lamp or voltmeter to a ground. If you are using a voltmeter, be sure it is the voltmeter's negative test lead you have connected to ground.
- B. Connect the other lead of the test lamp or voltmeter to a selected test point(connector or terminal).
- C. If the test lamp glows, there is voltage present. If you are using a voltmeter, note the voltage reading. A loss of more than 1 volt from specification indicates a problem.

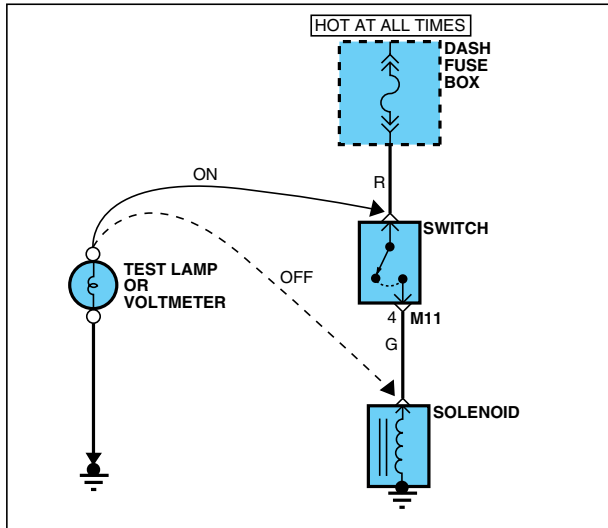

**2. TESTING FOR CONTINUITY**

- A. Disconnect the battery negative terminal.
- B. Connect one lead of a self-powered test lamp or ohmmeter to one end of the part of the circuit you wish to test. If you are using an ohmmeter, hold the leads together and adjust the ohmmeter to read zero ohms.
- C. Connect the other lead to the other end.
- D. If the self-power test lamp glows, there is continuity. If you are using an ohmmeter, low or zero resistance means good continuity.

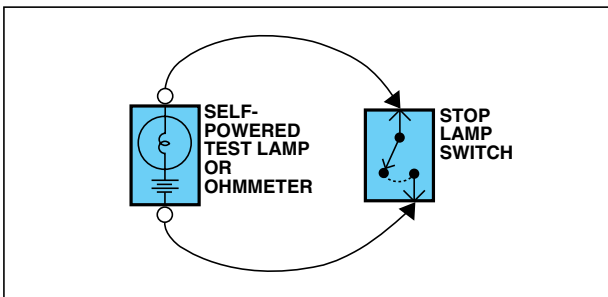

**3. TESTING FOR SHORT TO GROUND**

- A. Disconnect the battery negative terminal.
- B. Connect one lead of a self-powered test lamp or an ohmmeter to the fuse terminal on the load side.
- C. Connect the other lead to a ground.
- D. Beginning near the fuse block move the harness from side to side. Continue this procedure (about six inches apart) while watching the self-powered test lamp or ohmmeter.
- E. When the self-powered test lamp glows, or ohmmeter registers, there is a short to a ground in the wiring near that point.

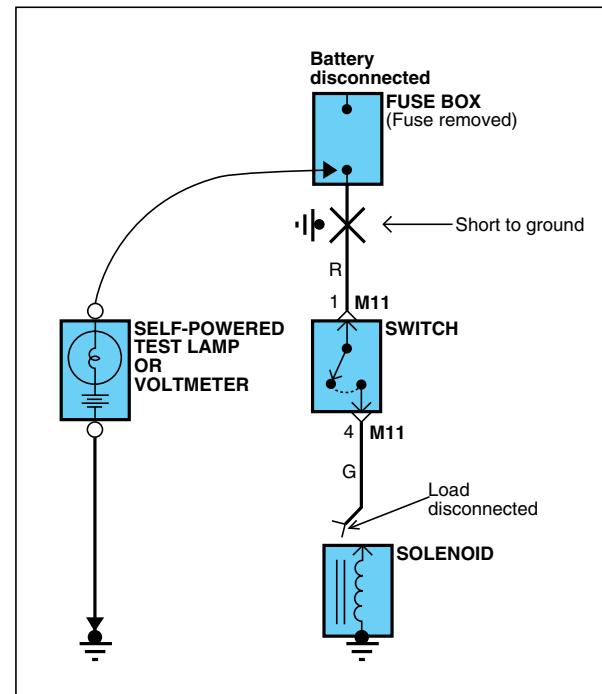

## 4. TESTING FOR A SHORT WITH A SHORT FINDER

- A. Remove the blown fuse. Leave the battery connected.
- B. Connect the short finder across the fuse terminals.
- C. Close all switches in series in the circuit that is being testing.
- D. Turn on the short circuit locator. It sends pulses of current to the short.  
This creates a pulsing magnetic field around the wiring between the fuse box and the short.
- E. Beginning at the fuse box, slowly move the short finder along the circuit wiring. The meter will show current pulses through sheet metal and body trim. As long as the meter is between the fuse and the short, the needle will move with each current pulse. Once the meter is moved past the point of the short, the needle will stop moving. Check around this area to locate the cause of the short circuit.

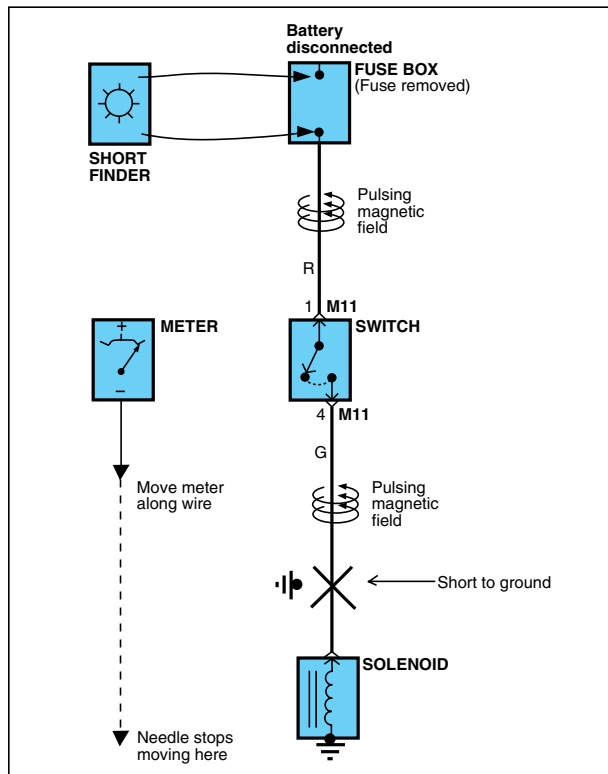

**\* REFERENCE SERVICE TOOLS**

Tool Number	Tool Name
TRK00A	Wiring Repair Kit (Standard Kit)
TRK001	Wire Stripper Set
TRK002	Remover Tool Set
TRK003	Terminal Tension Gauge Set
TRK004	Cable Tie Set
TRK005	Shrink Tube Set
TRK006	Jump Connector Kit(A)
TRK007~10	General Connector Kit(B~E)
TRK011	Terminal With Lead Wire Kit(F)
TRK012	Composition Kit(G)
TRK013	Lead Wire Set
TRK014	Carrying Case
TRK015	User's Guide & Parts Information
TRK016	Inner Box(Large)
TRK017	Inner Box(Small)
TRK018	Solder

\* For more details, refer to the User's guide & parts Information of the Wiring Repair Kit (Pub. No. : OSG200208).

**\* Wiring Repair Kit**

[Standard Kit (TRK00A)]

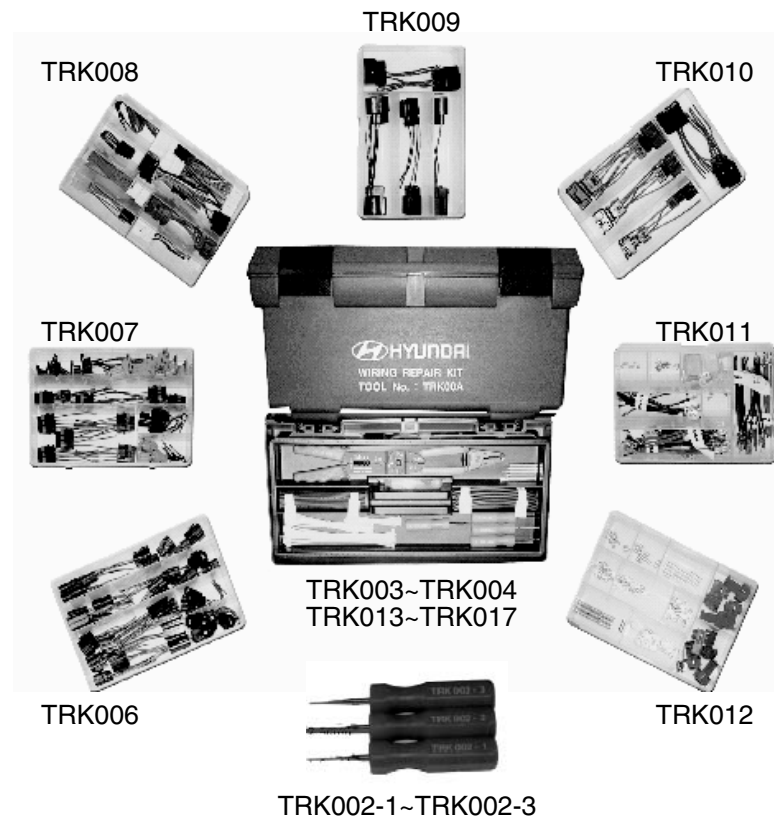

**\* Optional Items**



**REWORK PROCEDURE**

**1. Use of Wire stripper set (TRK001)**

- 1) Disconnect the battery cable.
- 2) Choose the correct clamping slot for the wire and strip off the wire coat.
- ◎ If the incorrect crimping slot is used, the terminal may be damaged and may not fit into the connector.

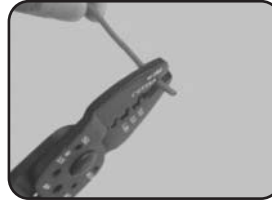

**2. Use of Remover tool set (TRK002)**

► **Flat tip type** : Removal of single locking male/female terminal from the connector.

- 1) Remove the front or rear retainer (holder, stopper) of the connector.



- 2) Ensure that the tip of the tool is inserted into the gap between the elastic arm of key and terminal.



- 3) Remove the terminal and check the terminal condition, if there is a damaged, replace it with a new terminal.

► **Double tip type** : Removal of double locking male/female terminal from the connector.



**3. Use of Terminal tension gauge set (TRK003)**

- 1) Select the tension gauge that matches the female terminal to be checked.



- 2) Insert a tension gauge into the female terminal and check the terminal condition. (as shown in the photograph)



◎ If the tension of female terminal is not tight enough, remove it and replace the terminal and wire assembly (including seal).



### 4. Use of Ring terminal (TRK012-4)

1) Strip off about 5mm of the wire coat at the end of the wire.



2) Joint the stripped wire with ring terminal and crimp using wire stripper.

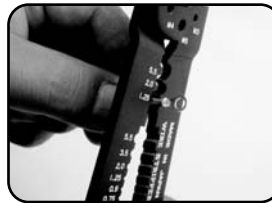

3) Put the shrink tube over the connection area and shrink the tube using electrical hot gun.



### 5. Use of Inline solder (TRK012-5) and Shrink tube set (TRK005)

1) Strip off about 5mm of the wire coat at the end of the wires.



2) Insert each wire into the opposite ends of the inline solder and crimp using wire stripper.



3) Put the shrink tube over the connection area and shrink the tube using electrical hot gun.



◎ Shrink tube should be securely wrapped around the inline solder area.

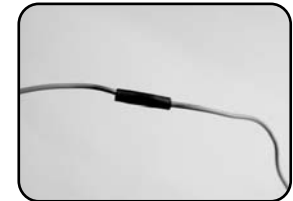

**6. Use of Terminal with lead wire kit (TRK011)**

- 1) Remove the damaged connector and terminal using remover tool.



- 2) Select the right wire, which is fitted with the terminal specification from terminal with lead wire box and cut of the end of wire using wire stripper.

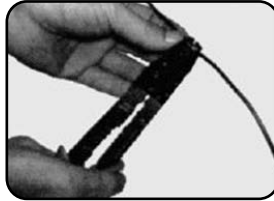

- 3) Put the end of each cut off wire in the middle of the splice joint terminal and compress using wire stripper.



- 4) Put the shrink tube over the connection area and shrink the tube using electrical hot gun.

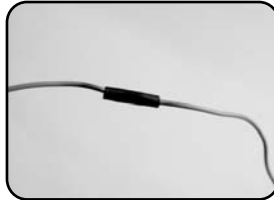

- 5) Insert the terminal with lead wire into the connector.



FUSE & RELAY INFORMATION (1)

SD100-1

PASSENGER COMPARTMENT JUNCTION BLOCK LAYOUT

< FRONT >

< REAR >

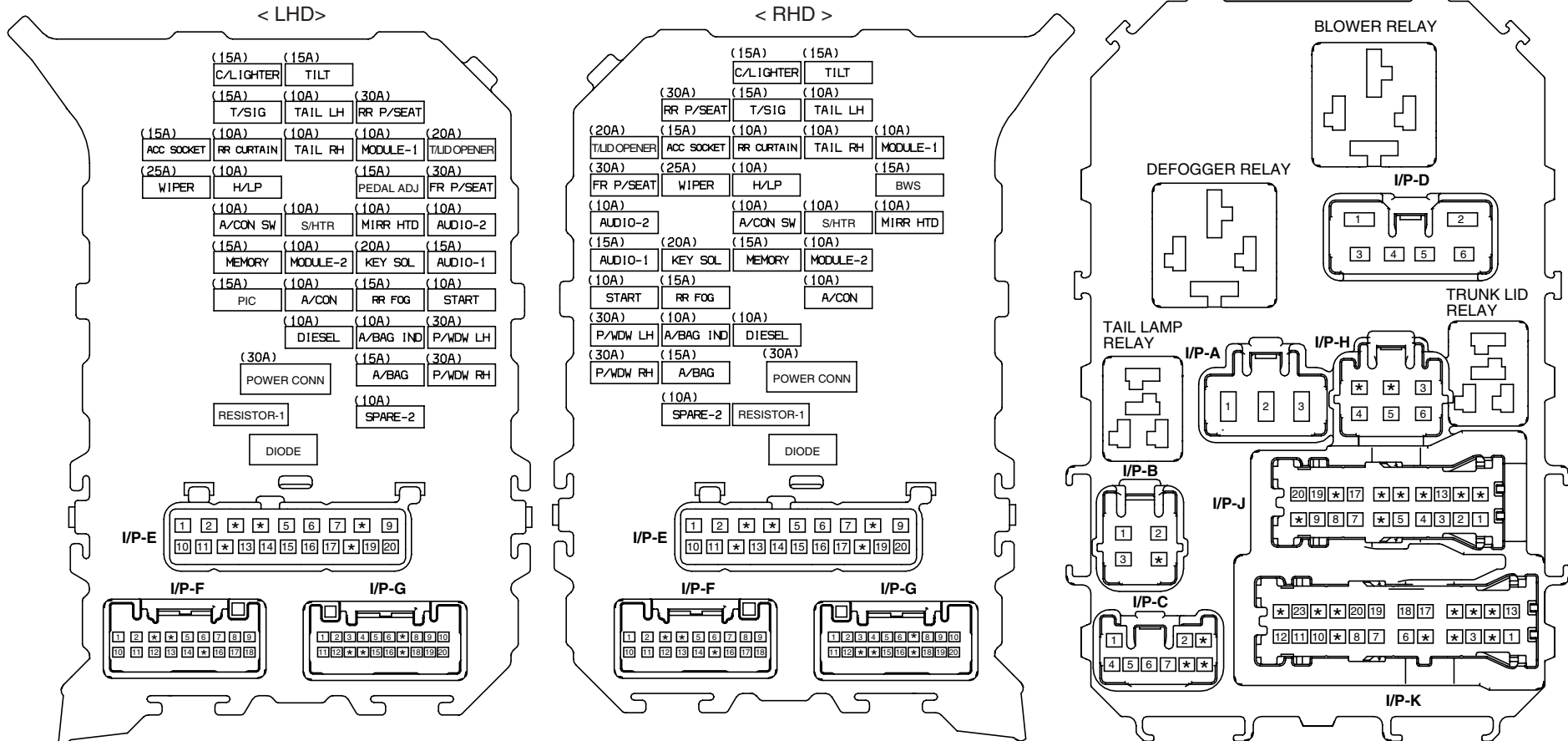

※ USE THE DESIGNATED FUSE ONLY



## FUSE & RELAY INFORMATION

### FUSE & RELAY INFORMATION (2)

SD100-2

#### CIRCUIT

FUSE	(A)	Circuit Protected
T/LID OPENER	20A	Fuel lid opener & Trunk lid switch
FR P/SEAT	30A	Front lumbar support switch, IMS control module, Driver/Passenger seat manual switch
AUDIO-2	10A	ATM key lock control module, Audio, IMS switch, Accessory relay, BCM, Digital clock & Passenger seat belt indicator
AUDIO-1	15A	Audio
START	10A	Transaxle range switch, Burglar alarm relay
P/WDW LH	30A	Left front safety window module, Left rear power window switch
P/WDW RH	30A	Right front safety window module, Right rear power window switch
RR P/SEAT	30A	Not used.
MODULE-1	10A	Instrument cluster, BCM, Rear curtain module, Rain sensor, IMS control module, Power window main switch
PEDAL ADJ(LHD) BWS(RHD)	15A	Back warning buzzer
MIRR HTD	10A	Left/Right outside mirror & Mirror folding motor, A/C control module
KEY SOL	20A	Key solenoid, Power window main switch
RR FOG	15A	Rear fog lamp relay
A/BAG IND	10A	Instrument cluster
A/BAG	15A	Air bag cut off switch, SRS control module
TILT	15A	Tilt & Telescopic module, Sport mode switch
TAIL LH	10A	Front fog lamp relay, Left rear combination lamp, License lamp, Left head lamp
TAIL RH	10A	Right rear combination lamp, License lamp, Right head lamp, Rheostat
S/HTR	10A	Driver/Passenger seat warmer switch
MODULE-2	10A	Instrument cluster, ESP switch, BCM, ATM key lock control module, YAW rate sensor, Multifunction switch
A/CON	10A	A/C control module, Tilt & Telescopic module, Rheostat, Electro chrome mirror, Sunroof motor, AQS & Ambient sensor
DIESEL	10A	PTC heater relay, Fuel filter relay
C/LIGHTER	15A	Cigarette lighter
T/SIG	15A	BCM
RR CURTAIN	10A	Rear curtain module
H/LP	10A	Head lamp relay, HID relay, Head lamp leveling actuator, Head lamp washer relay
A/CON SW	10A	A/C control module, Blower relay, Blower motor
MEMORY	15A	Data link connector, A/C control module, Instrument cluster, Multifunction switch, Tilt & Telescopic module, BCM, Door warning switch, Room lamp, Left/Right foot lamp, Door lamp, IMS control module
ACC SOCKET	15A	Rear power outlet
WIPER	25A	Washer relay, Wiper relay(High), Wiper motor
PIC(LHD)	15A	Not used.
POWER CONN	30A	Fuse(MEMORY 15A, AUDIO-1 15A)

# FUSE & RELAY INFORMATION

## FUSE & RELAY INFORMATION (3)

SD100-3

### ENGINE COMPARTMENT JUNCTION BLOCK LAYOUT

< FRONT >

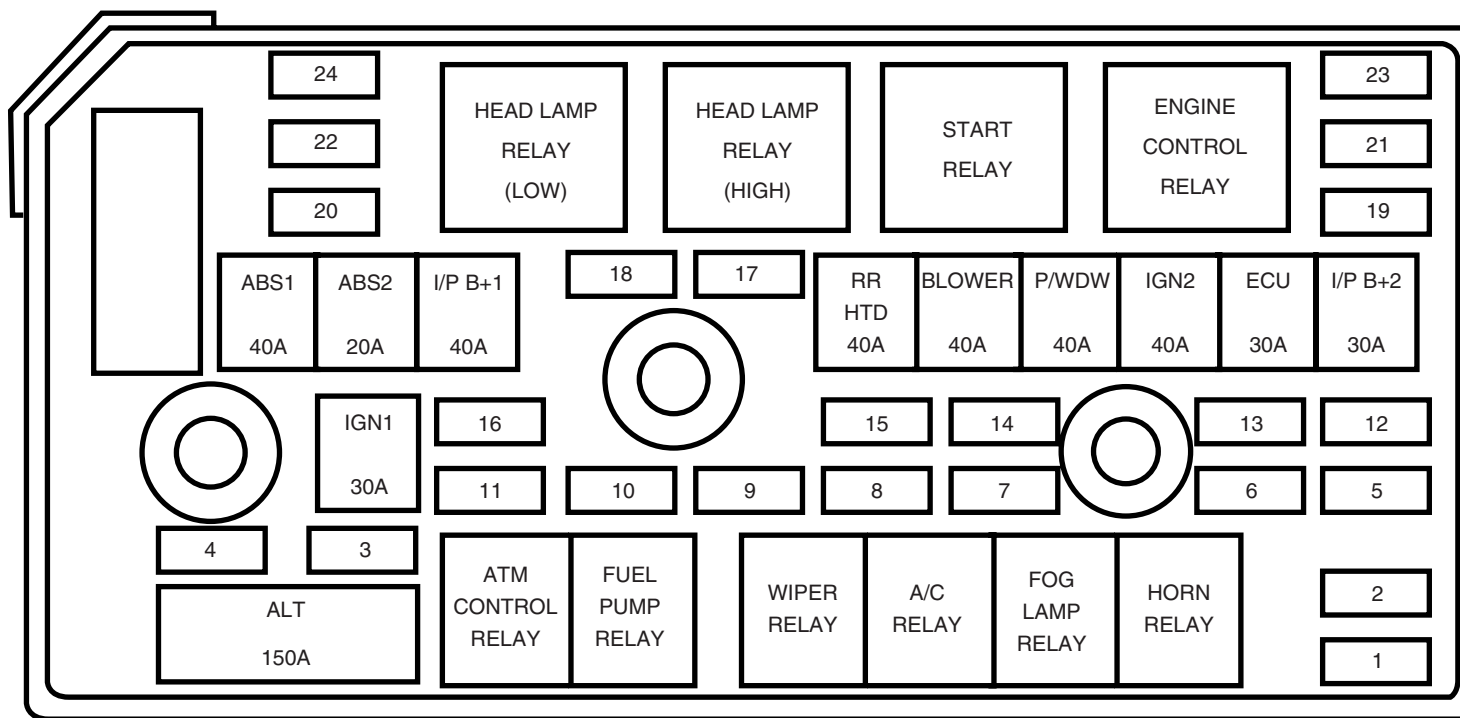

※ USE THE DESIGNATED FUSE ONLY

## FUSE & RELAY INFORMATION

### FUSE & RELAY INFORMATION (4)

SD100-4

#### CIRCUIT

FUSIBLE LINK & FUSE	(A)	Circuit Protected	
ABS1	40A	ABS control module, ESP module, Multipurpose check connector	
ABS2	20A	ABS control module, ESP module, Multipurpose check connector	
I/P B+1	40A	Fuse(FR P/SEAT, T/LID OPENER, T/SIG, TILT, PEDAL ADJ, BWS, RR CURTAIN)	
RR HTD	40A	Defogger relay	
BLOWER	40A	Blower relay	
P/WDW	40A	Fuse(P/WDW LH, P/WDW RH)	
IGN2	40A	Ignition switch(IG2, START), Start relay	
ECU	30A	Engine control relay, PCM, ECM	
I/P B+2	30A	Fuse(KEY SOL, RR FOG), Power connector	
IGN1	30A	Ignition switch(ACC, IG1)	
ALT	150A	Fusible link(ABS1, ABS2, RR HTD, BLOWER)	
1	HORN	15A	Horn relay
2	TAIL	20A	Tail lamp relay
3	ECU	10A	PCM(Gasoline)
4	IG1	10A	TCM(Diesel)
5	DRL	15A	Burglar alarm horn relay, DRL relay
6	FR FOG	15A	Front fog lamp relay
7	A/CON	10A	A/C relay
8	F/PUMP	20A	Fuel pump relay
9	Diode	-	Not used
10	ATM	20A	ATM control relay
11	STOP	15A	Stop lamp switch
12	H/LP LO RH	15A	HID relay
13	SUN ROOF	15A	Overhead console lamp(Sunroof motor)
14	H/LP WASHER	20A	Head lamp washer relay
15	H/LP HI	20A	Head lamp relay(HIGH)
16	ECU(B+)	10A	PCM, TCM, Generator
17	SNSR3	10A	Injector, A/C relay, Cooling fan relay, Lambda sensor
18	SNSR1	15A	Mass air flow sensor, PCM, Immobilizer module, Oil control valve, Variable intake manifold valve, Camshaft position sensor, EGR actuator
19	SNSR2	15A	O <sub>2</sub> sensor, Fuel pump relay, PCM, VGT actuator
20	B/UP	10A	Stop lamp switch, Transaxle range switch, Pulse generator, Vehicle speed sensor
21	IGN COIL	20A	Ignition coil(Gasoline), Condenser(Gasoline)
22	ECU(IG1)	10A	PCM, ECM, Air flow sensor
23	H/LP LO	20A	Head lamp relay(LOW)
24	ABS	10A	ABS control module, Multipurpose check connector, ESP module

**※ USE THE DESIGNATED FUSE ONLY**

# FUSE & RELAY INFORMATION

## FUSE & RELAY INFORMATION (5)

SD100-5

### ENGINE COMPARTMENT JUNCTION BLOCK LAYOUT

< REAR >

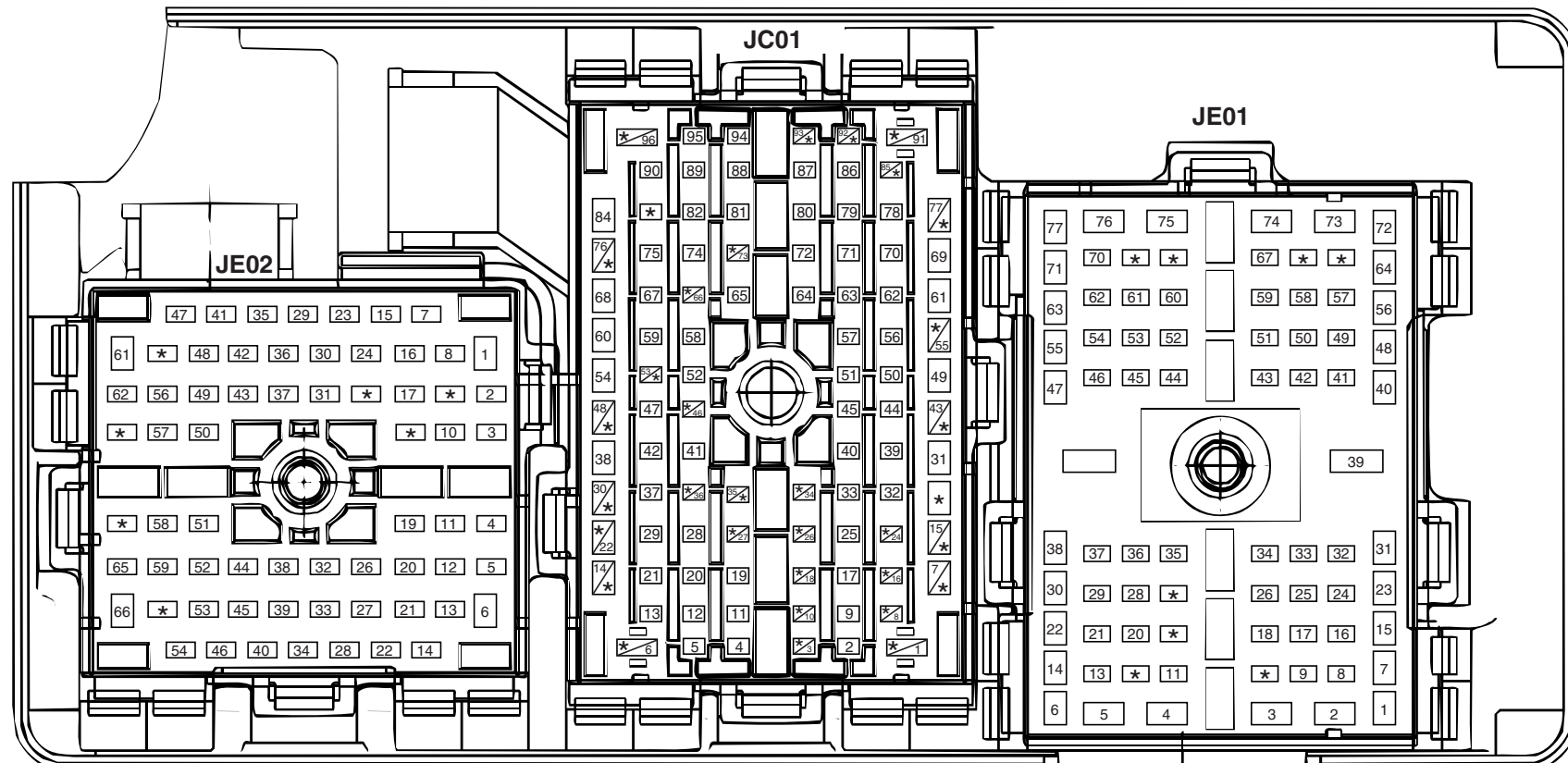

※ GSL ← → DSL

# FUSE & RELAY INFORMATION

## FUSE & RELAY INFORMATION (6)

SD100-6

### ICM RELAY BOX LAYOUT

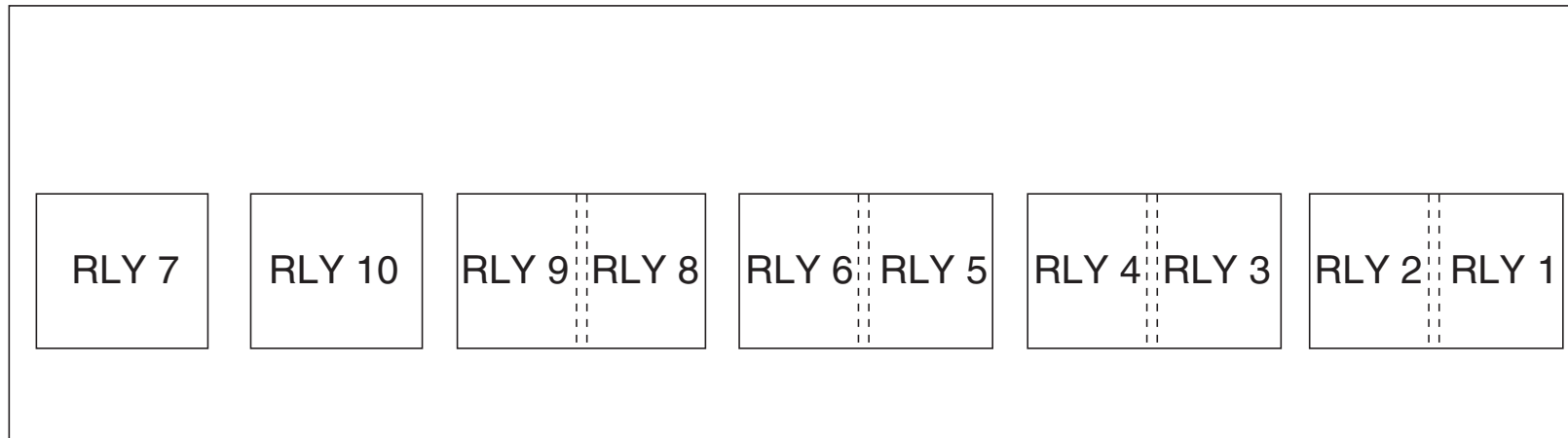

### RELAY NAME

NO	NAME	NO	NAME
1	Burglar alarm relay	6	Head lamp washer relay
2	Burglar alarm horn relay	7	DRL relay
3	Wiper relay(High)	8	Accessory relay
4	Washer relay	9	Not used
5	Not used	10	Rear fog lamp relay

## FUSE & RELAY INFORMATION

### FUSE & RELAY INFORMATION (7)

SD100-7

#### FRONT FUSE BOX(GASOLINE)

#### LAYOUT

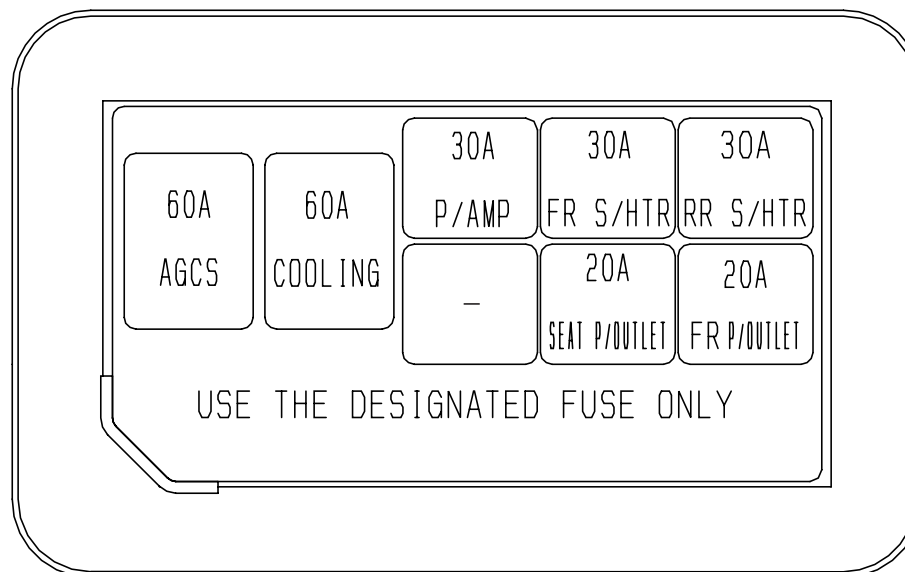

FUSIBLE LINK & FUSE	(A)	Circuit Protected
AGCS	60A	Not used
COOLING	60A	Cooling fan relay
P/AMP	30A	Premium amp
FR S/HTR	30A	Driver/Passenger seat warmer module
RR S/HTR	30A	Not used
SEAT P/OUTLET	20A	Not used
FR P/OUTLET	20A	Accessory relay

**※ USE THE DESIGNATED FUSE ONLY**

# FUSE & RELAY INFORMATION

## FUSE & RELAY INFORMATION (8)

SD100-8

### FRONT FUSE BOX(DIESEL)

#### LAYOUT

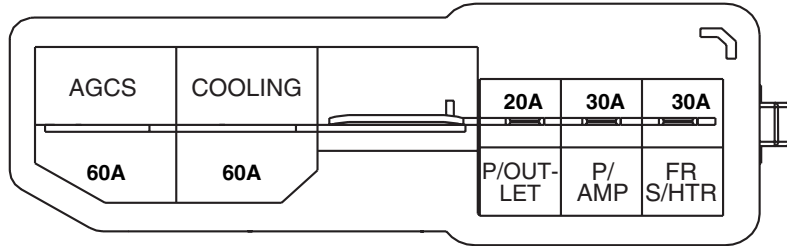

FUSIBLE LINK & FUSE	(A)	Circuit Protected
AGCS	60A	Not used
COOLING	60A	Cooling fan relay
P/AMP	30A	Premium amp
FR S/HTR	30A	Driver/Passenger seat warmer module
P/OUTLET	20A	Accessory relay

### FUSIBLE LINK BOX(DIESEL)

#### LAYOUT

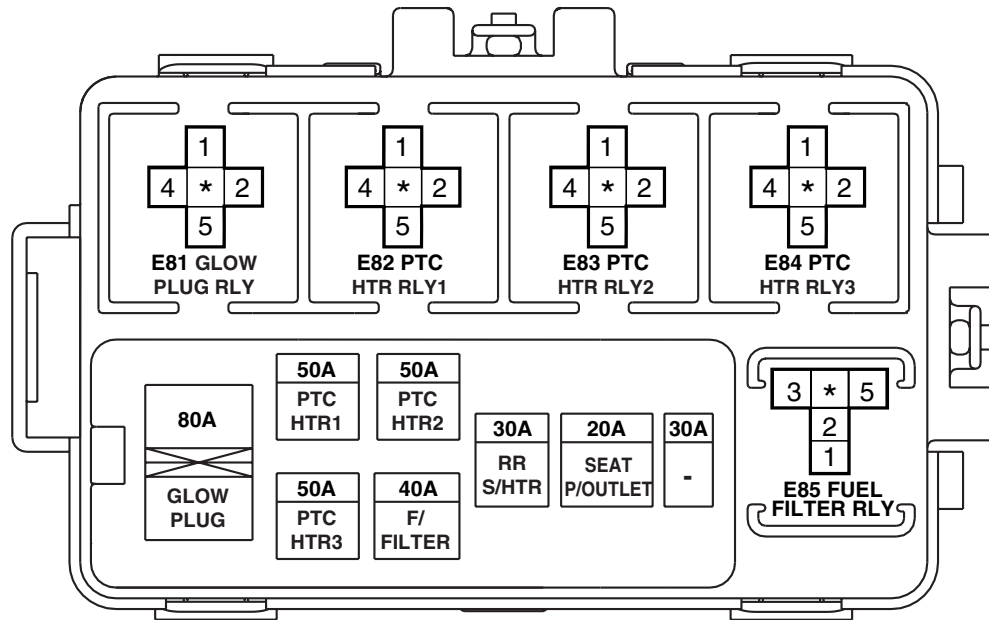

FUSIBLE LINK & FUSE	(A)	Circuit Protected
GLOW PLUG	80A	Glow plug relay
PTC HTR #1	50A	PTC heater relay #1
PTC HTR #2	50A	PTC heater relay #2
PTC HTR #3	50A	PTC heater relay #3
F/FILTER	40A	Fuel filter relay
RR S/HTR	30A	Not used
SEAT P/OUTLET	20A	Not used

⌘ USE THE DESIGNATED FUSE ONLY

POWER DISTRIBUTION (1)

SD110-1

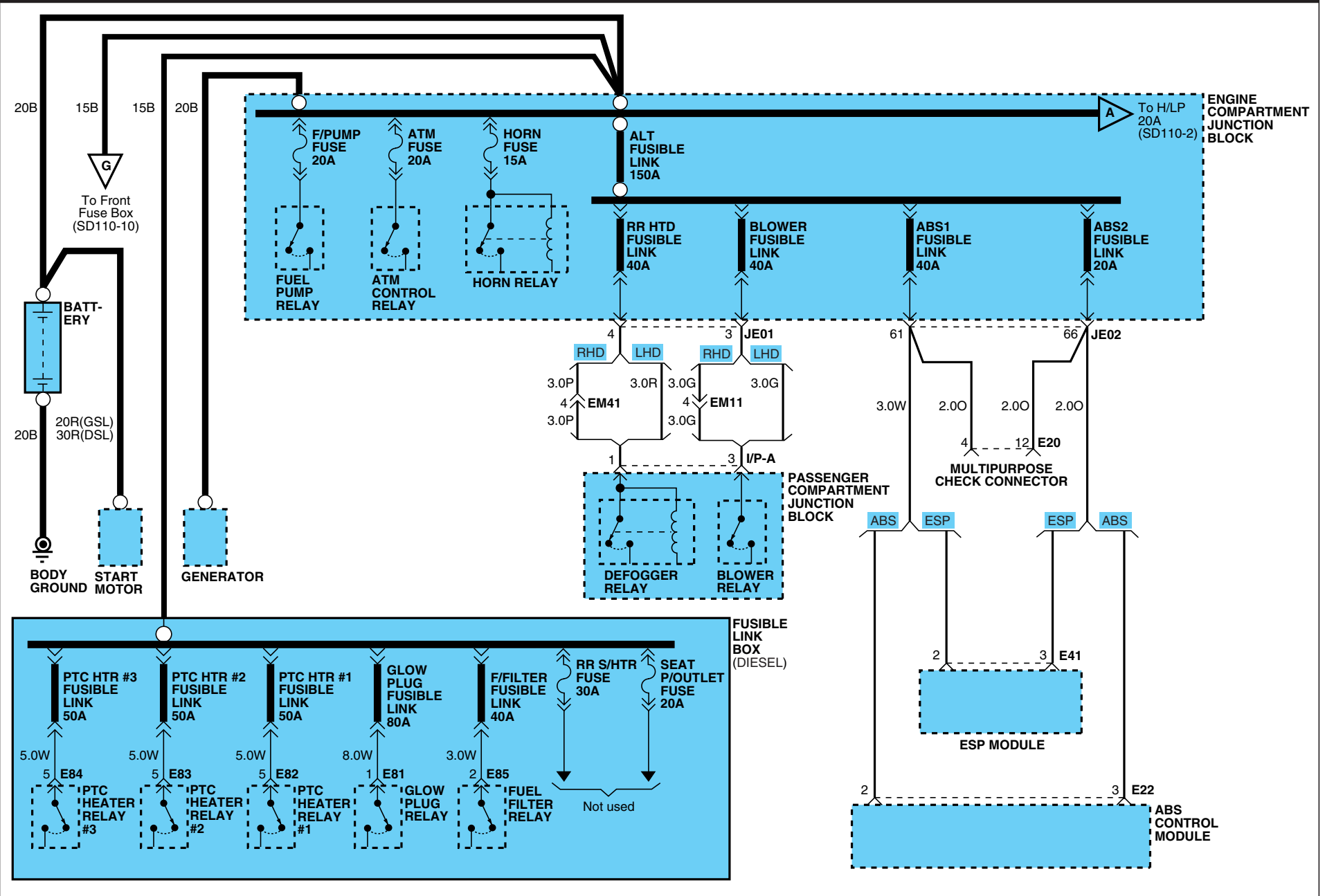



# POWER DISTRIBUTION

## POWER DISTRIBUTION (2)

SD110-2

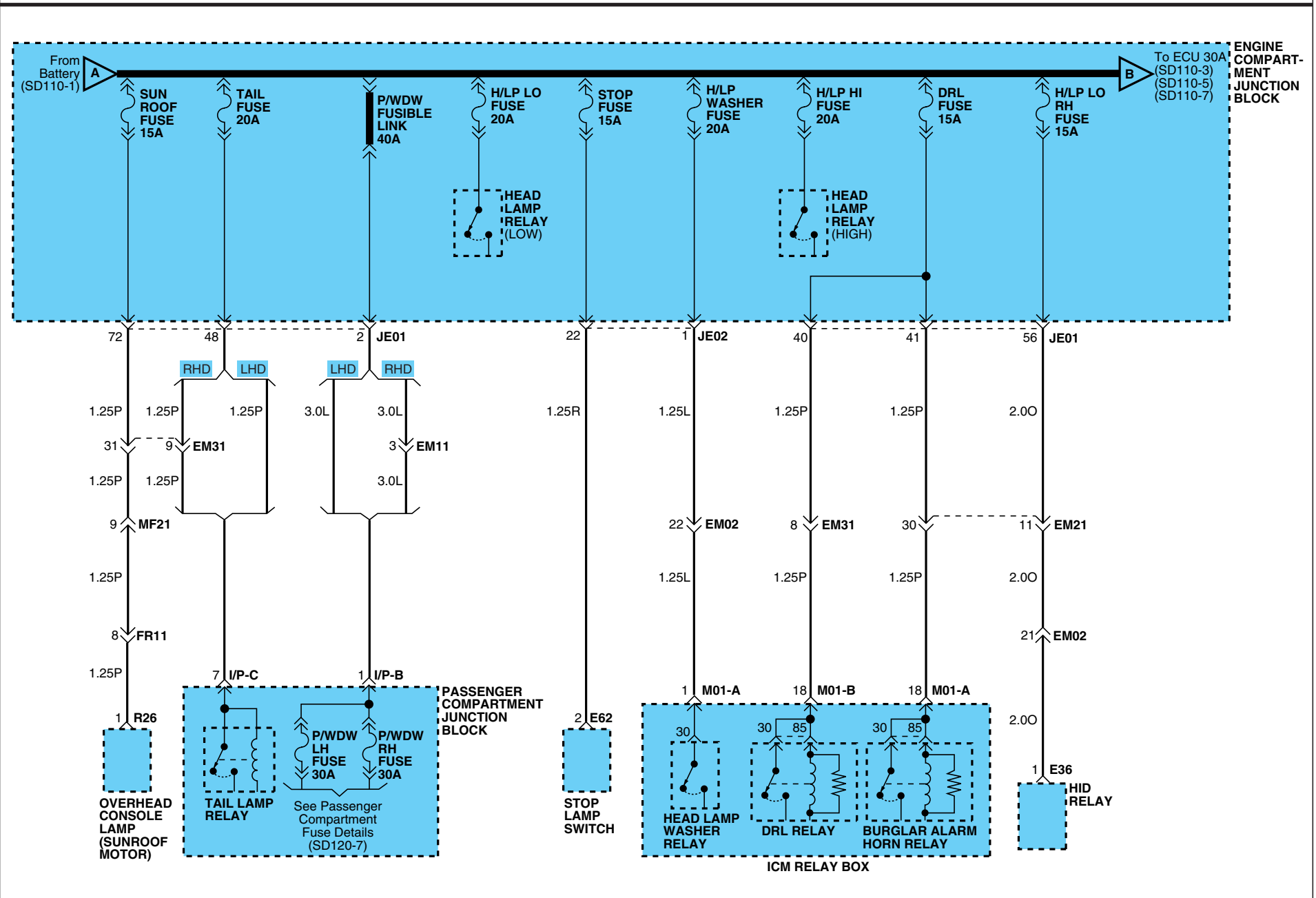

# POWER DISTRIBUTION

## POWER DISTRIBUTION (3)

SD110-3

### GSL 2.7L

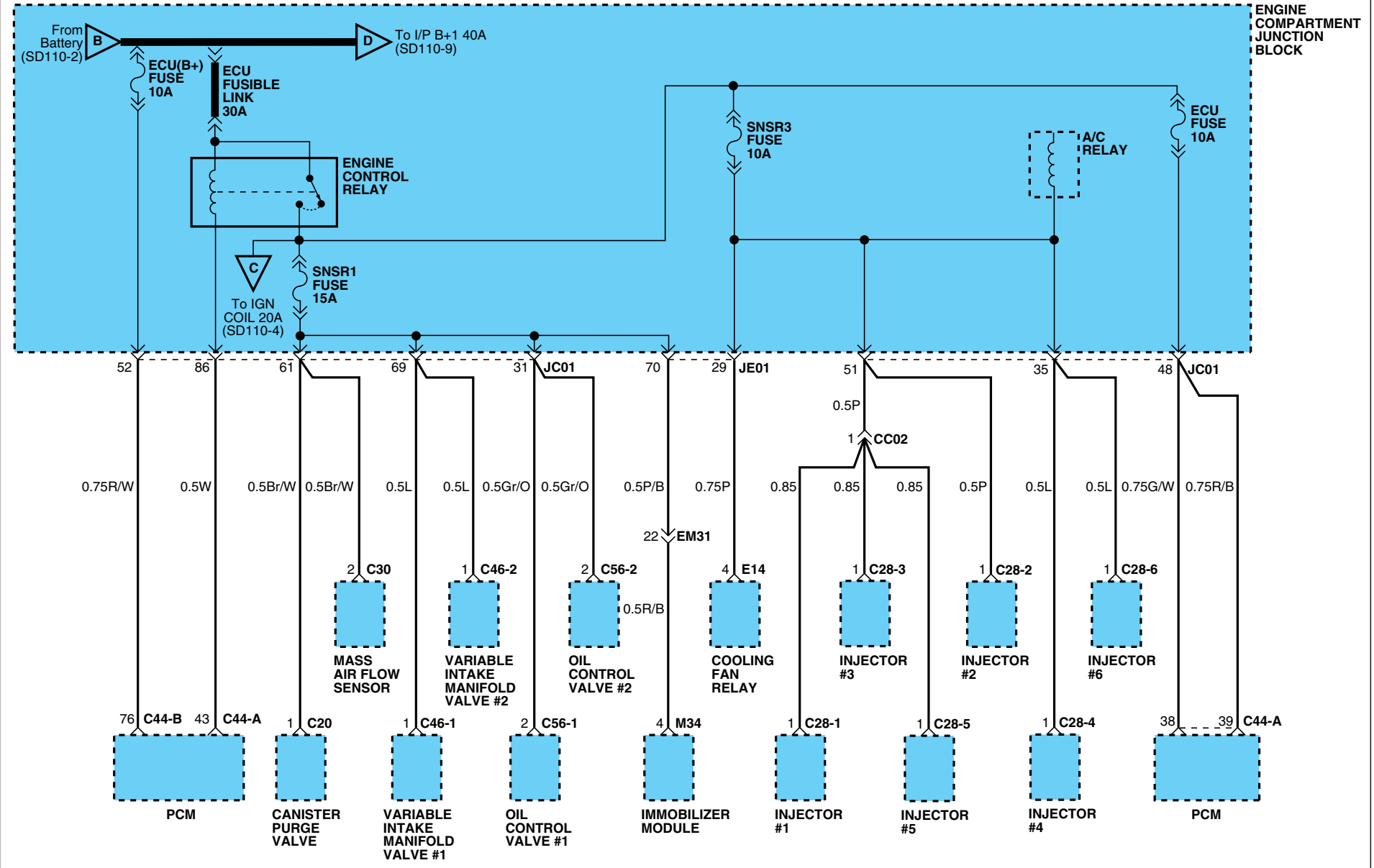

# POWER DISTRIBUTION

## POWER DISTRIBUTION (4)

SD110-4

### GSL 2.7L

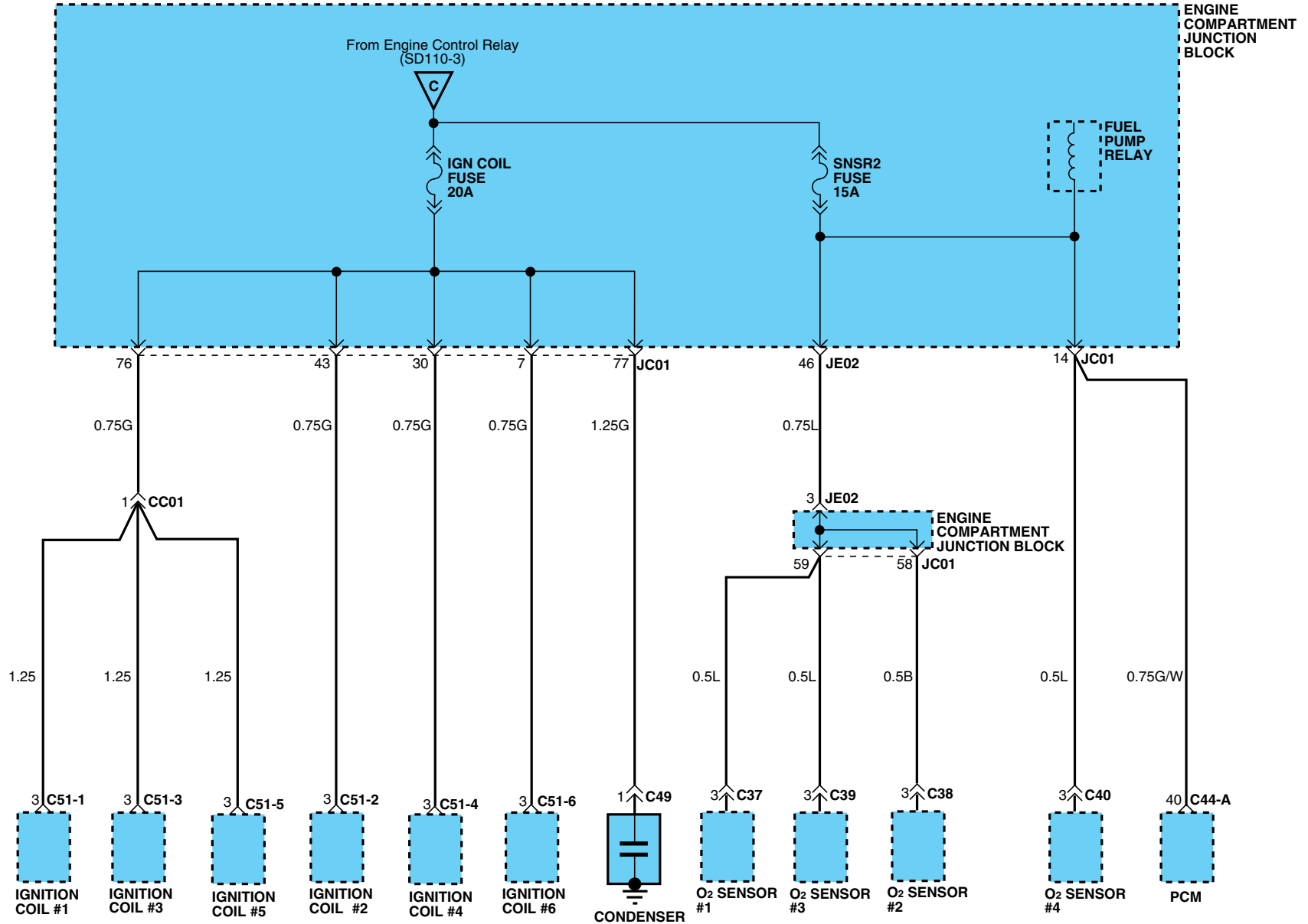

**POWER DISTRIBUTION**

**POWER DISTRIBUTION (5)**

**SD110-5**

**GSL 3.3L/3.8L**

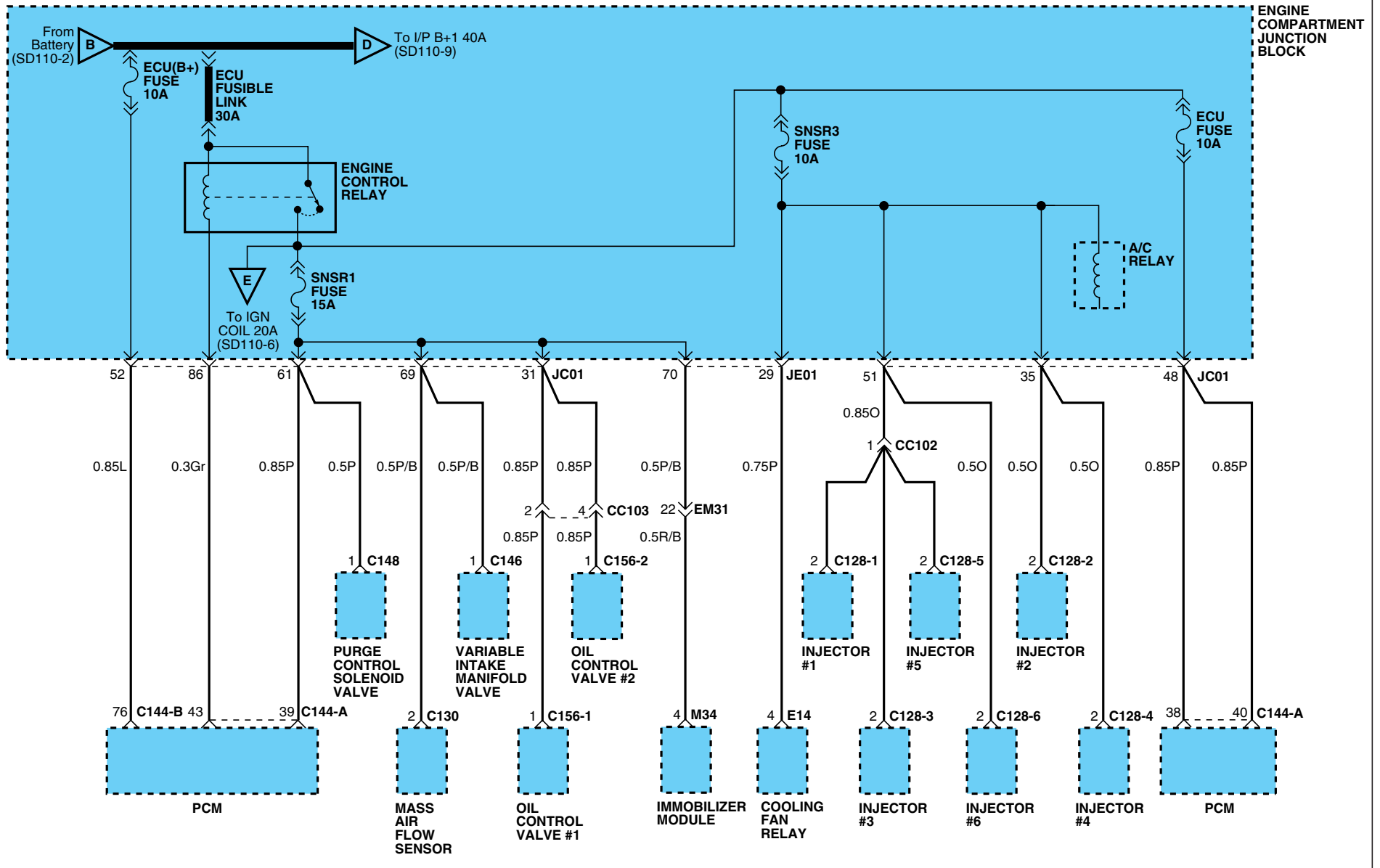

# POWER DISTRIBUTION

## POWER DISTRIBUTION (6)

SD110-6

### GSL 3.3L/3.8L

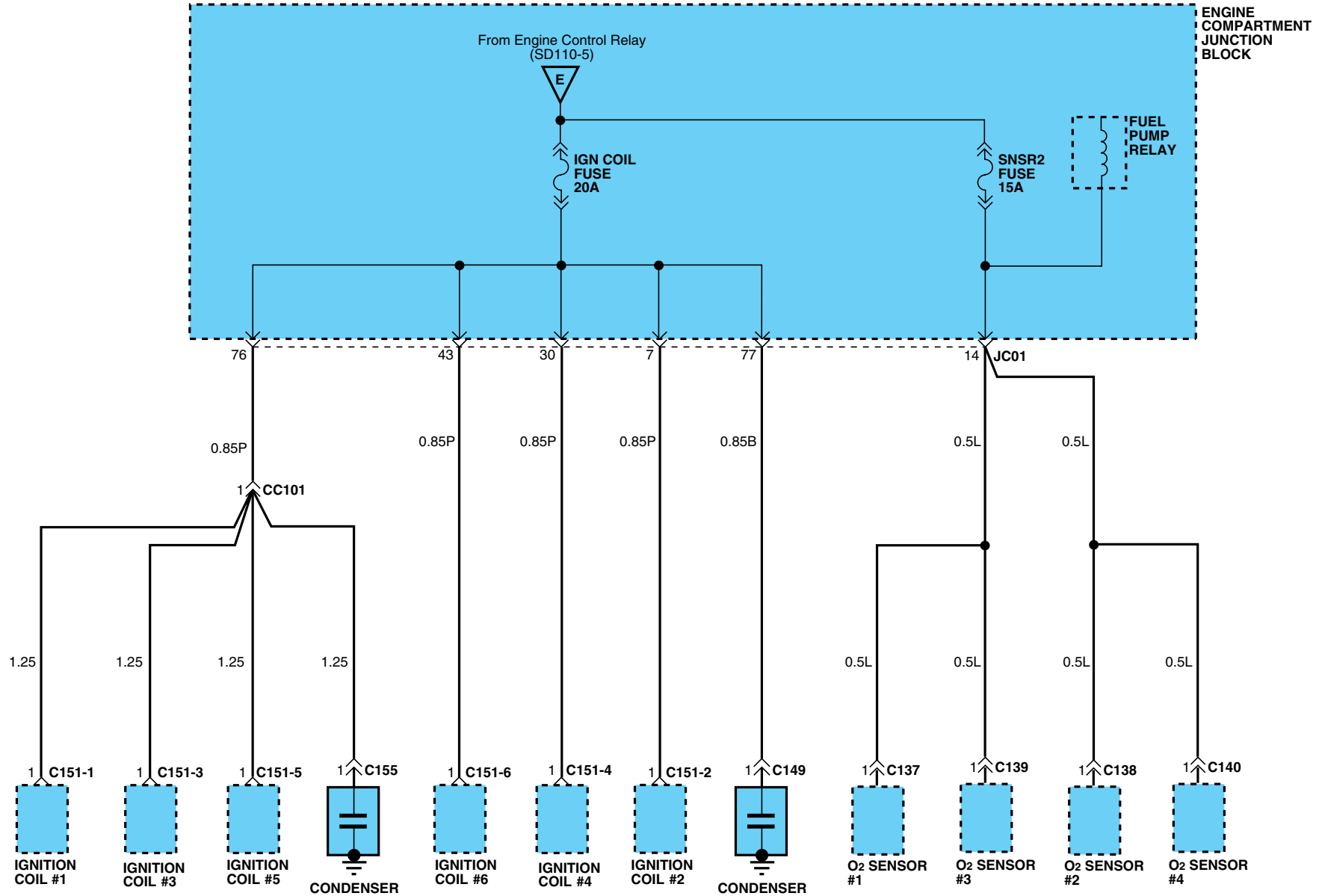

# POWER DISTRIBUTION

## POWER DISTRIBUTION (7)

SD110-7

### DIESEL

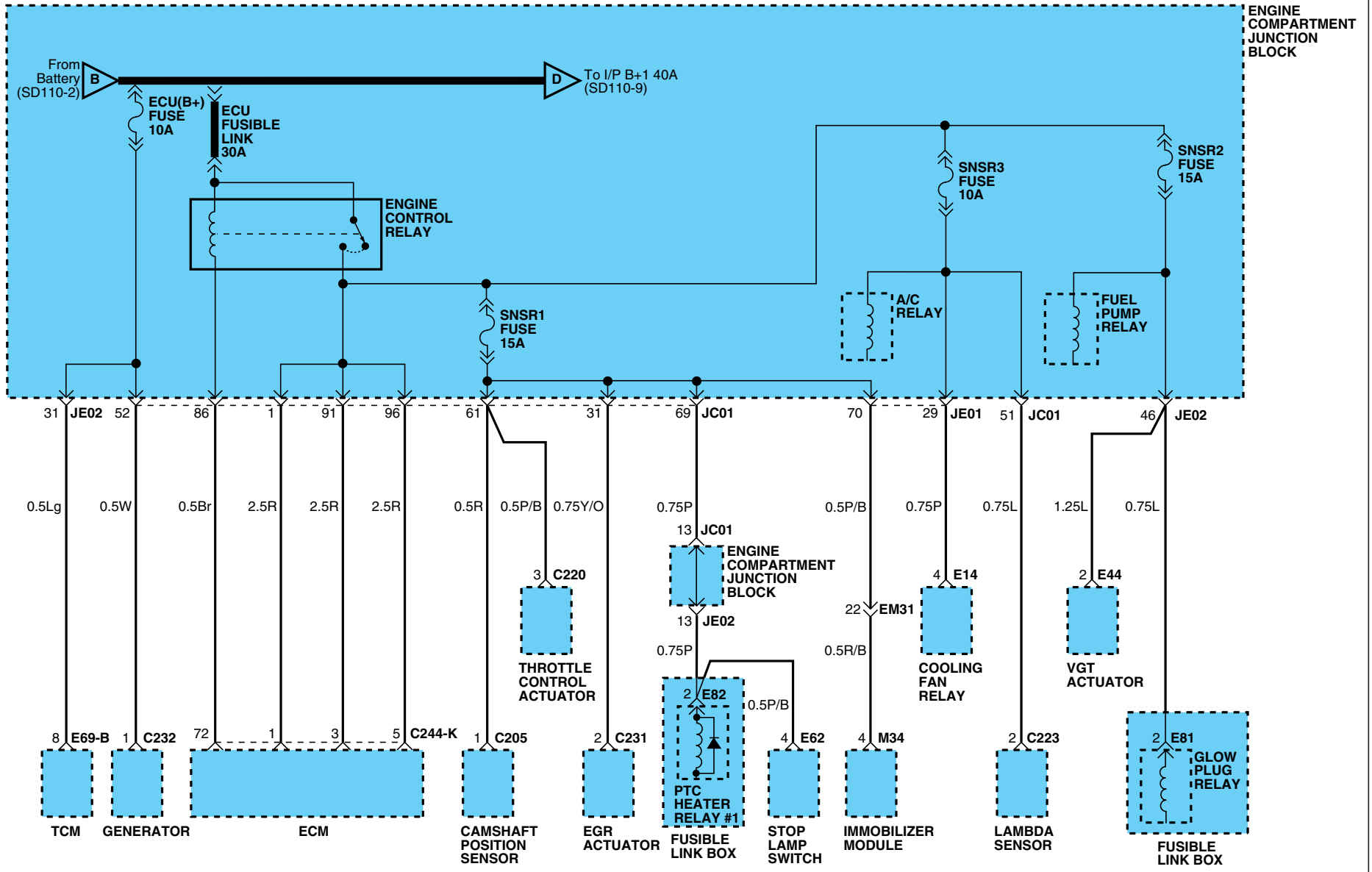

# POWER DISTRIBUTION

## POWER DISTRIBUTION (8)

SD110-8

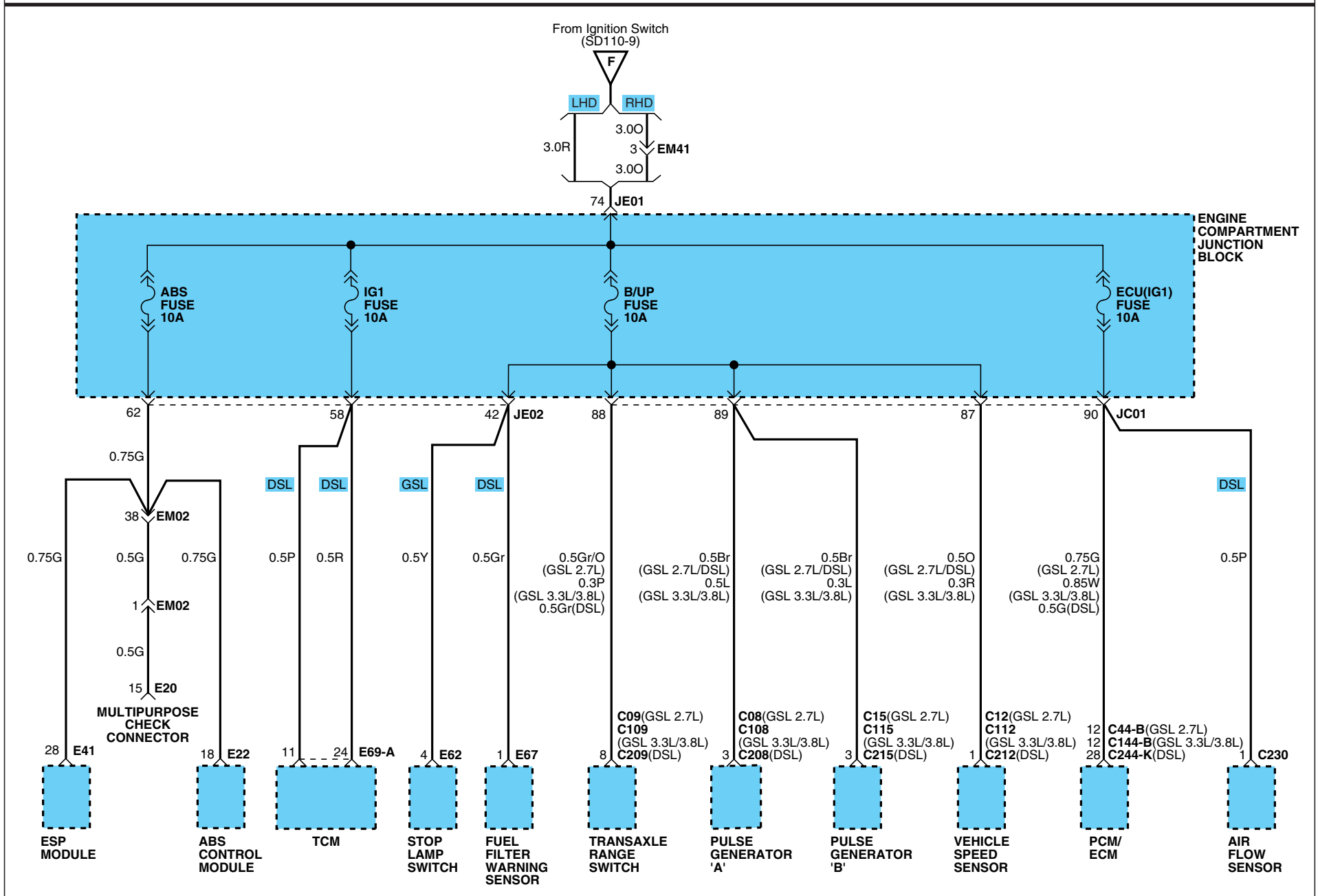

# POWER DISTRIBUTION

## POWER DISTRIBUTION (9)

SD110-9

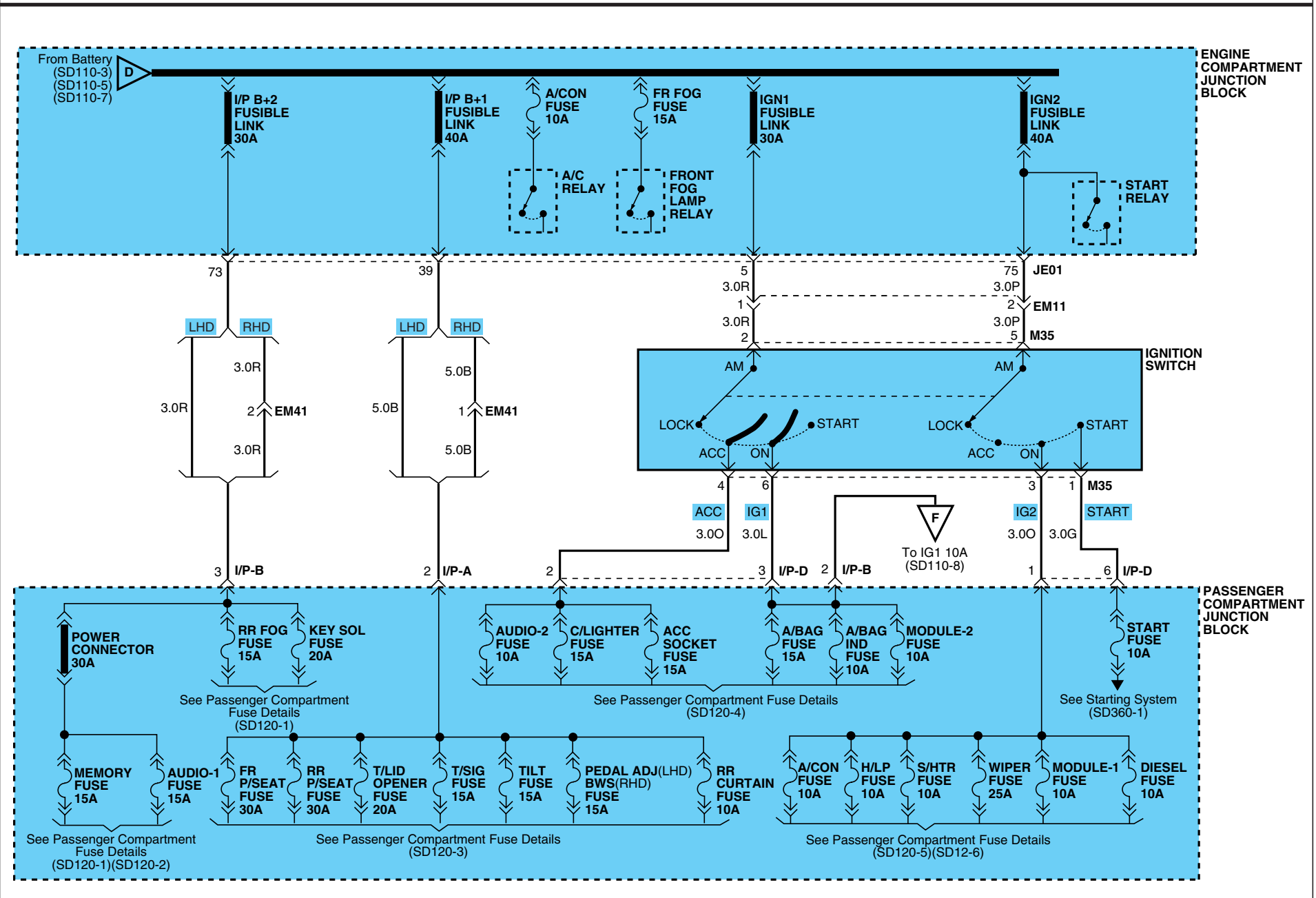



# POWER DISTRIBUTION

## POWER DISTRIBUTION (10)

SD110-10

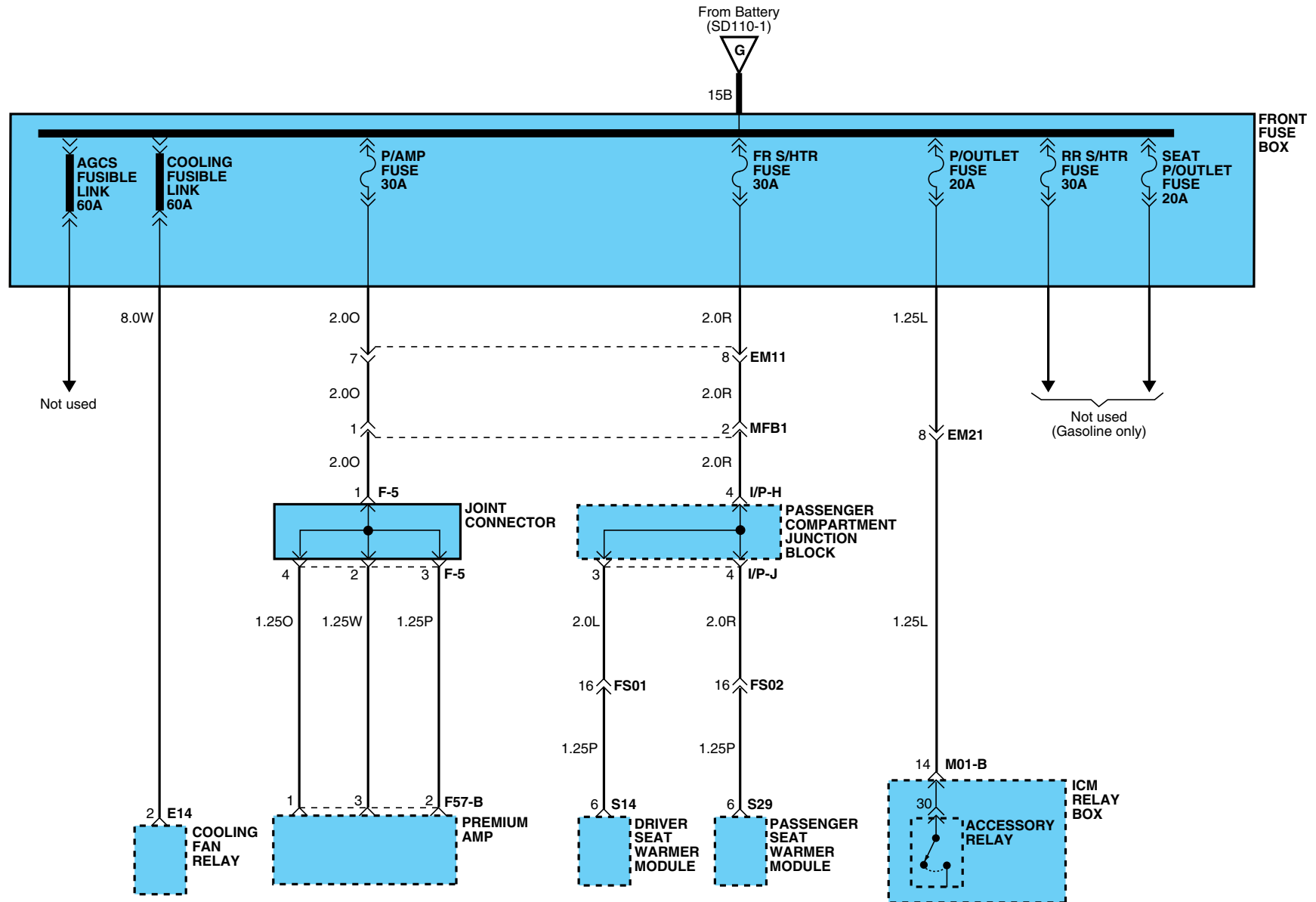

PASSENGER COMPARTMENT FUSE DETAILS (1)

SD120-1

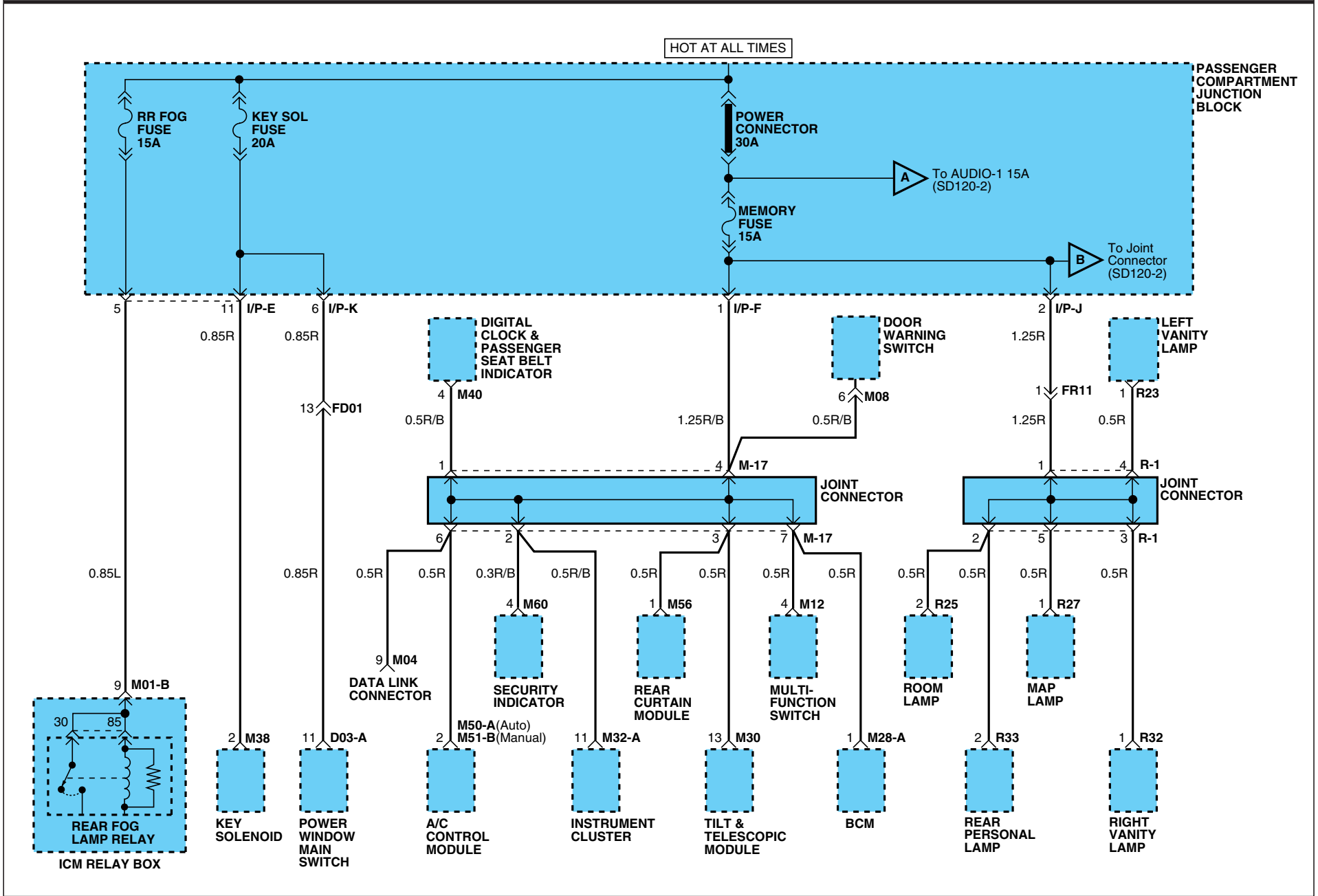

# PASSENGER COMPARTMENT FUSE DETAILS

## PASSENGER COMPARTMENT FUSE DETAILS (2)

SD120-2

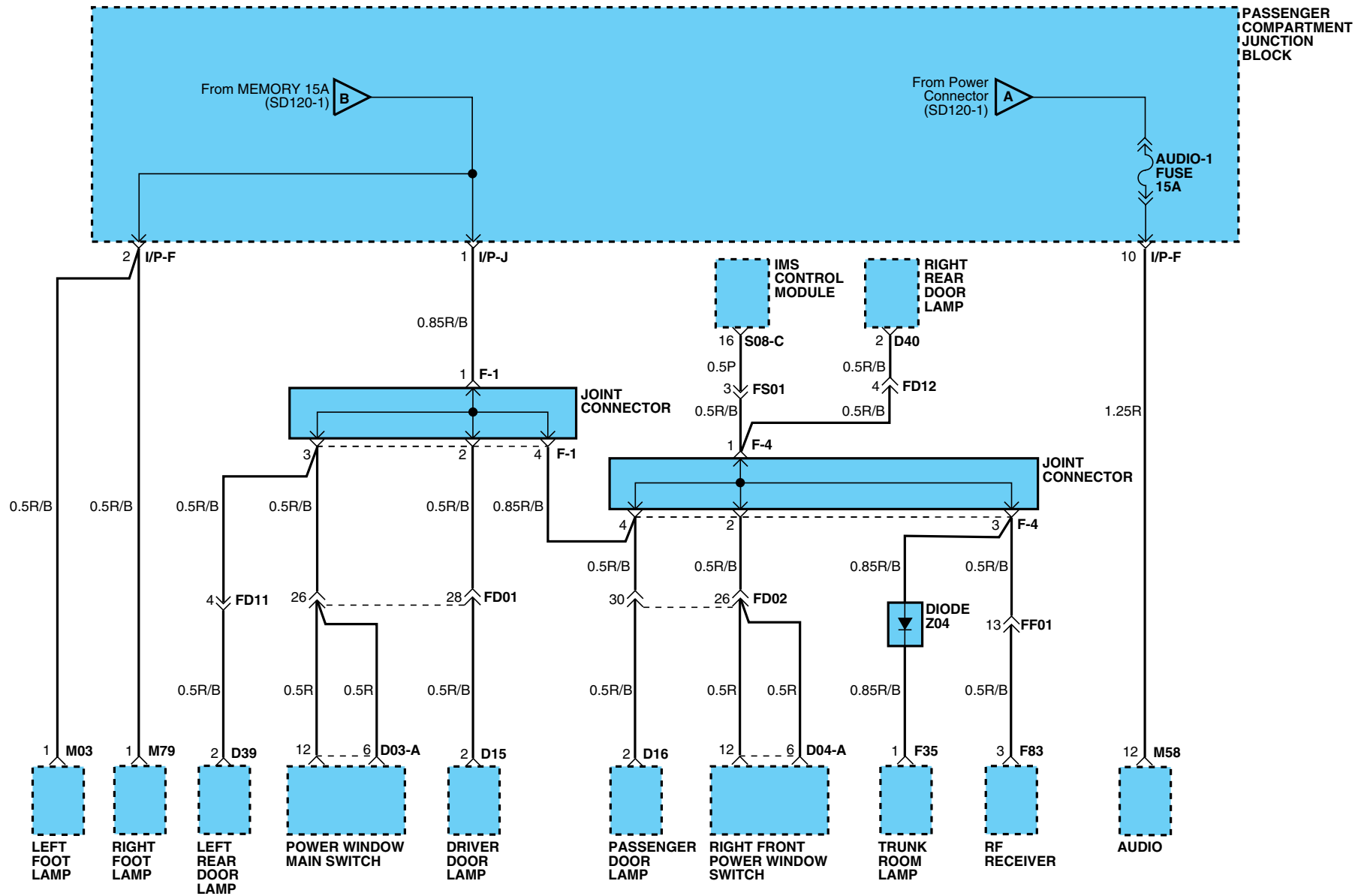

# PASSENGER COMPARTMENT FUSE DETAILS

## PASSENGER COMPARTMENT FUSE DETAILS (3)

SD120-3

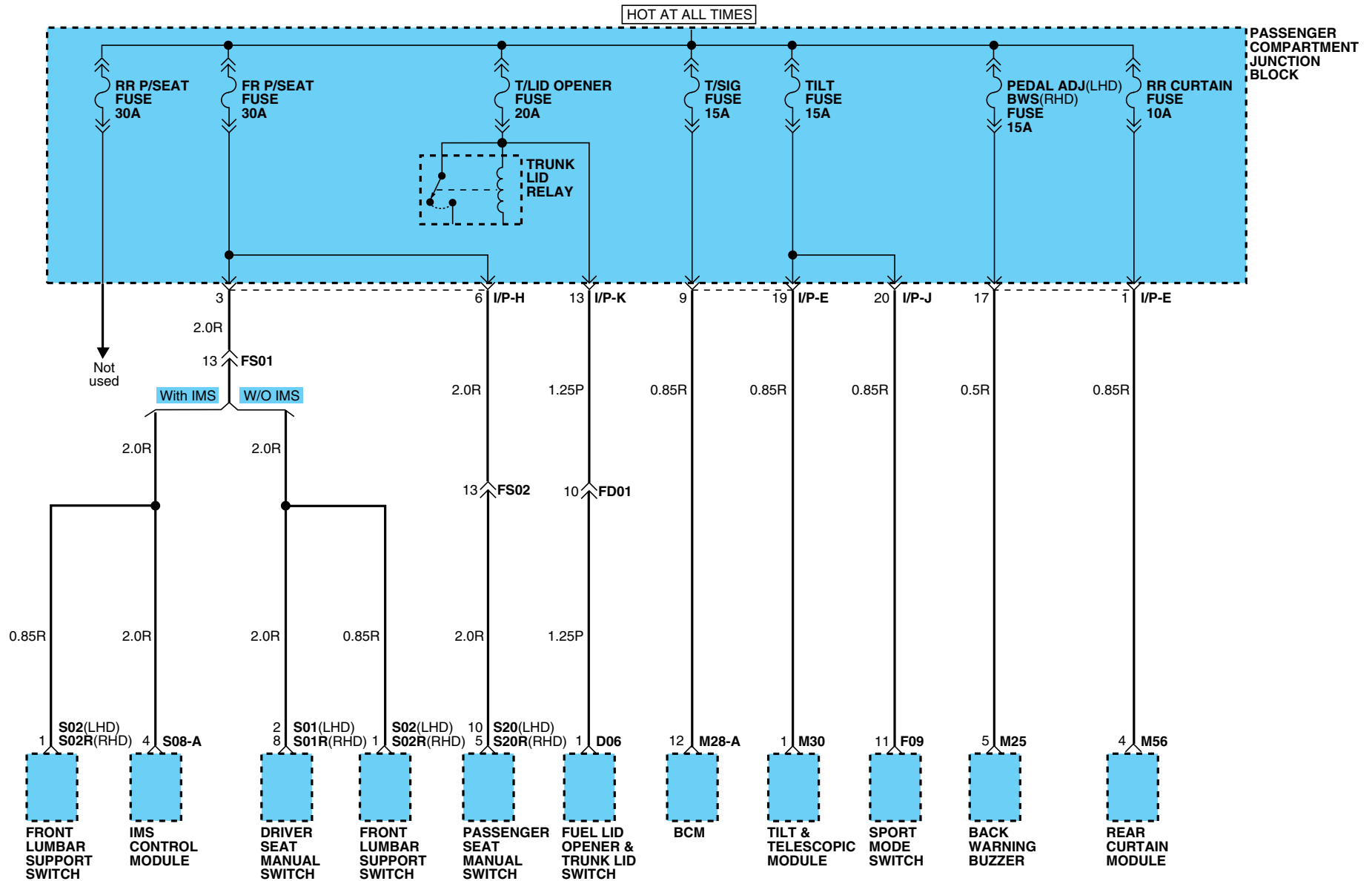

# PASSENGER COMPARTMENT FUSE DETAILS

## PASSENGER COMPARTMENT FUSE DETAILS (4)

SD120-4

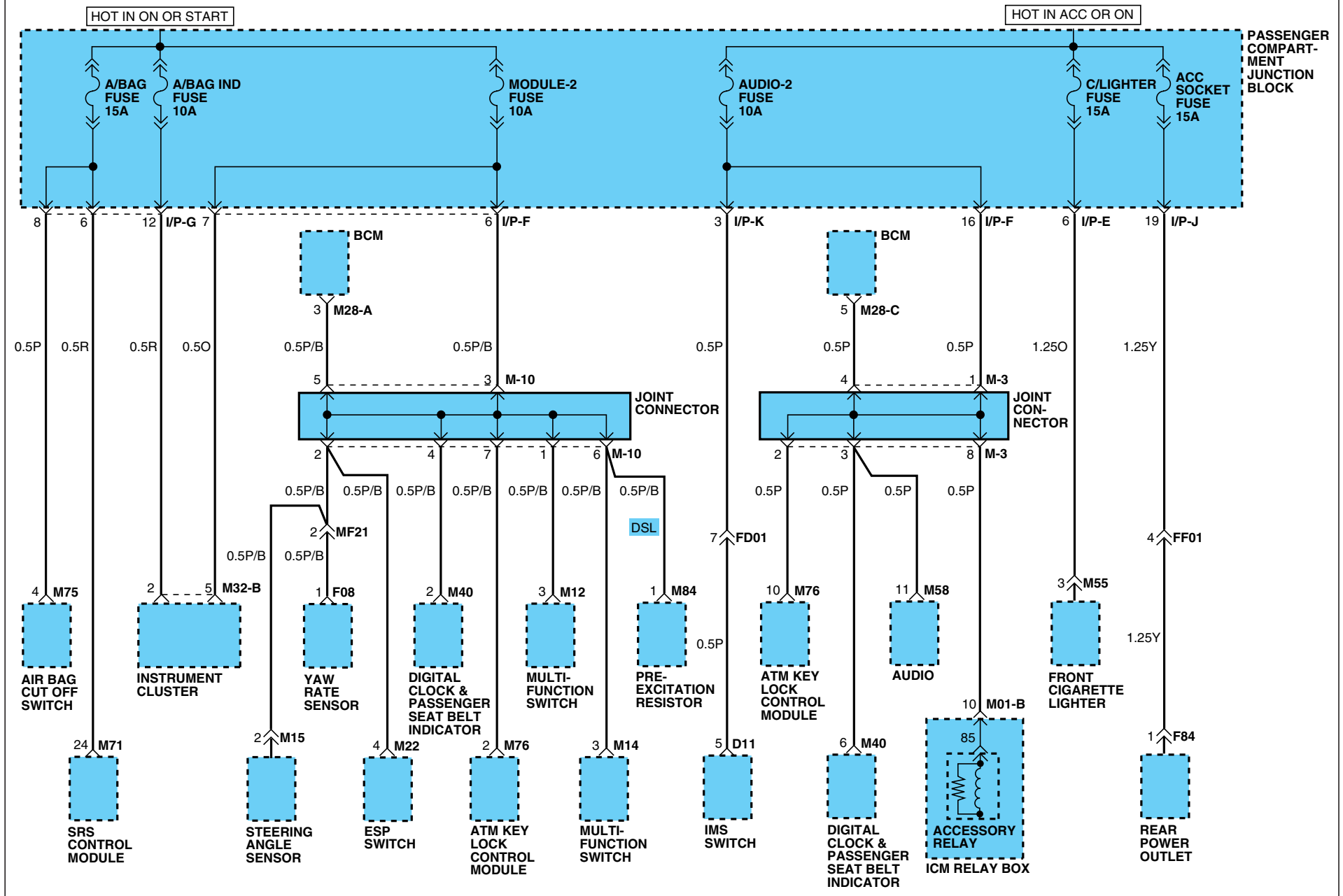

# PASSENGER COMPARTMENT FUSE DETAILS

## PASSENGER COMPARTMENT FUSE DETAILS (5)

SD120-5

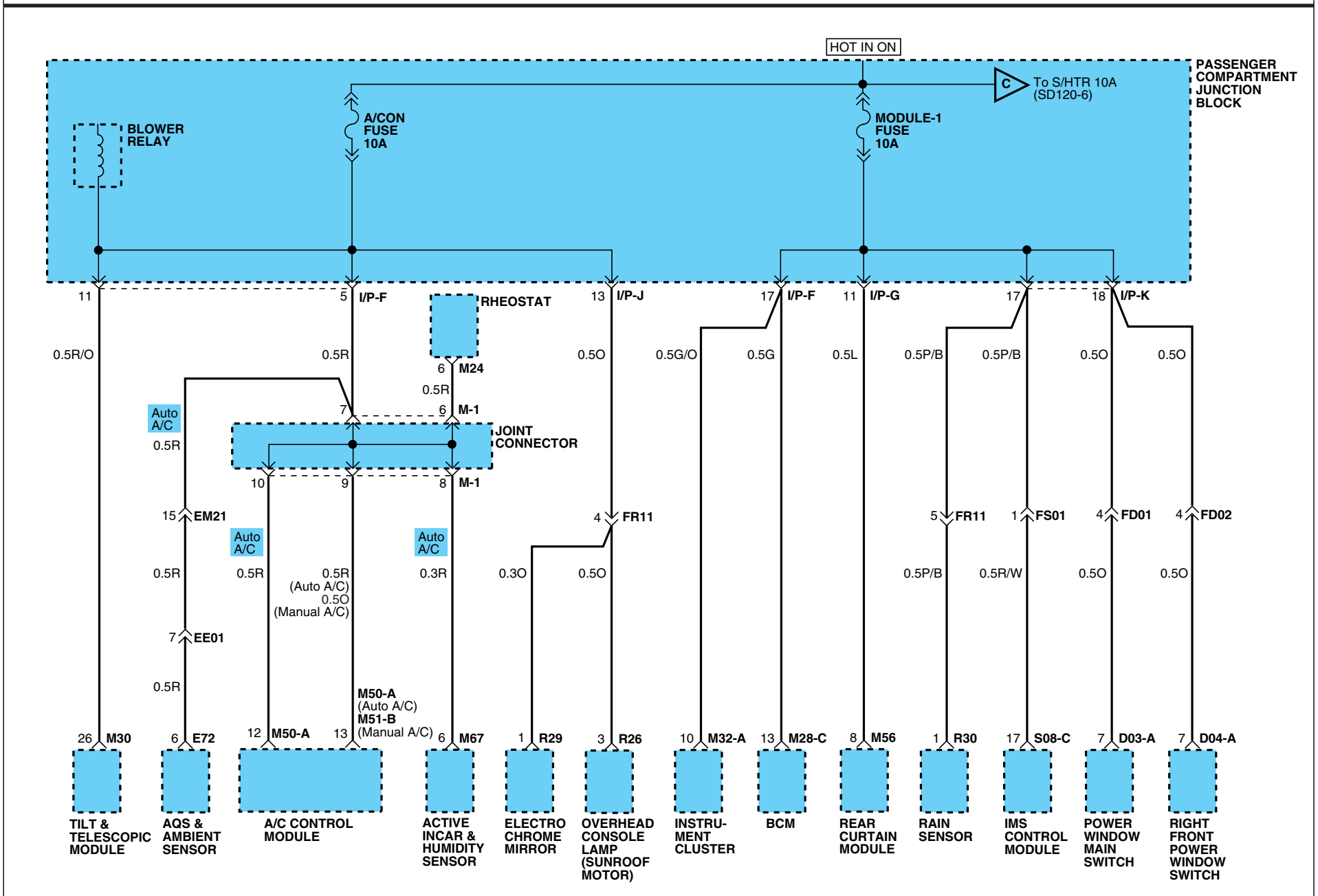

# PASSENGER COMPARTMENT FUSE DETAILS

## PASSENGER COMPARTMENT FUSE DETAILS (6)

SD120-6

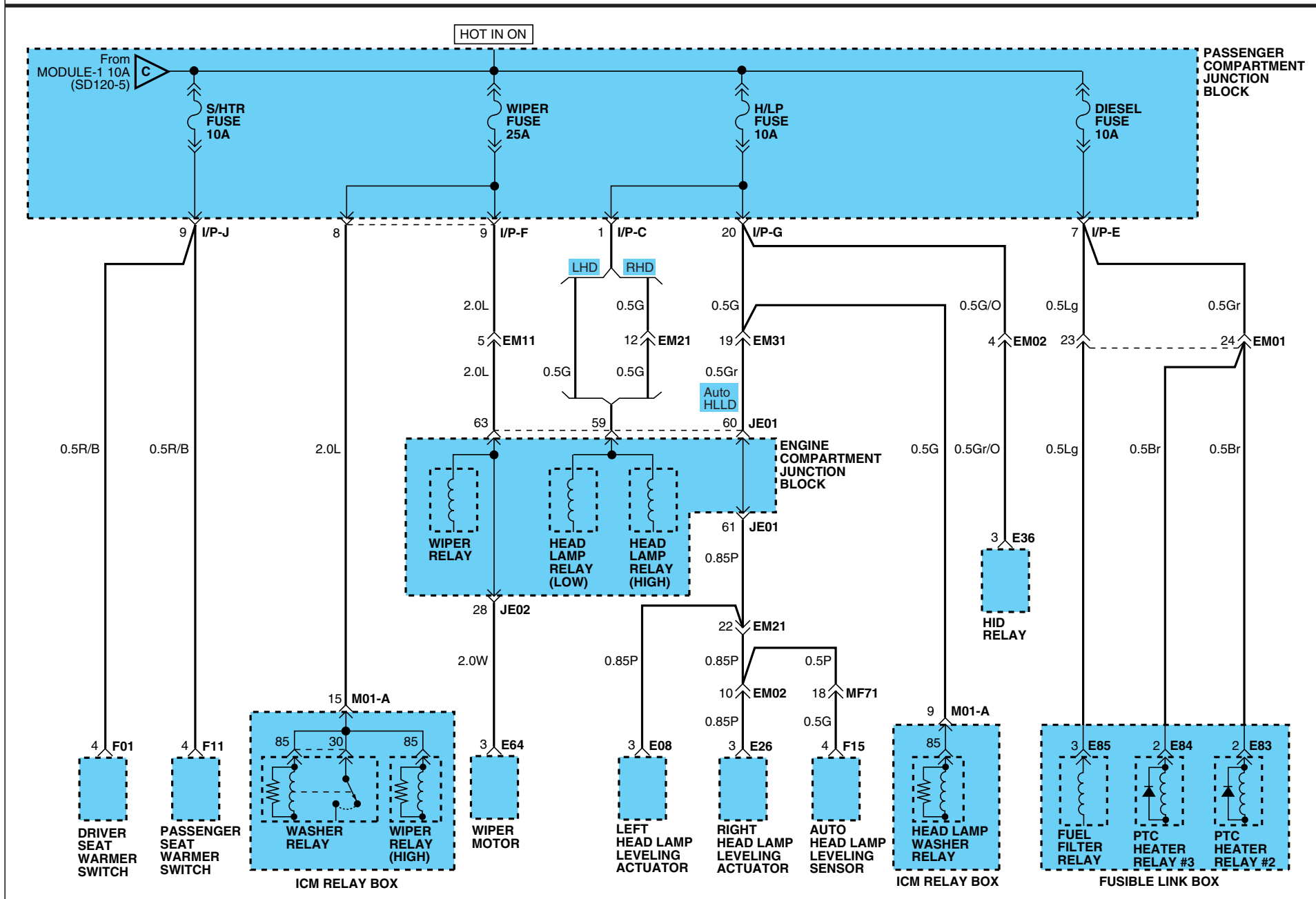

# PASSENGER COMPARTMENT FUSE DETAILS

## PASSENGER COMPARTMENT FUSE DETAILS (7)

SD120-7

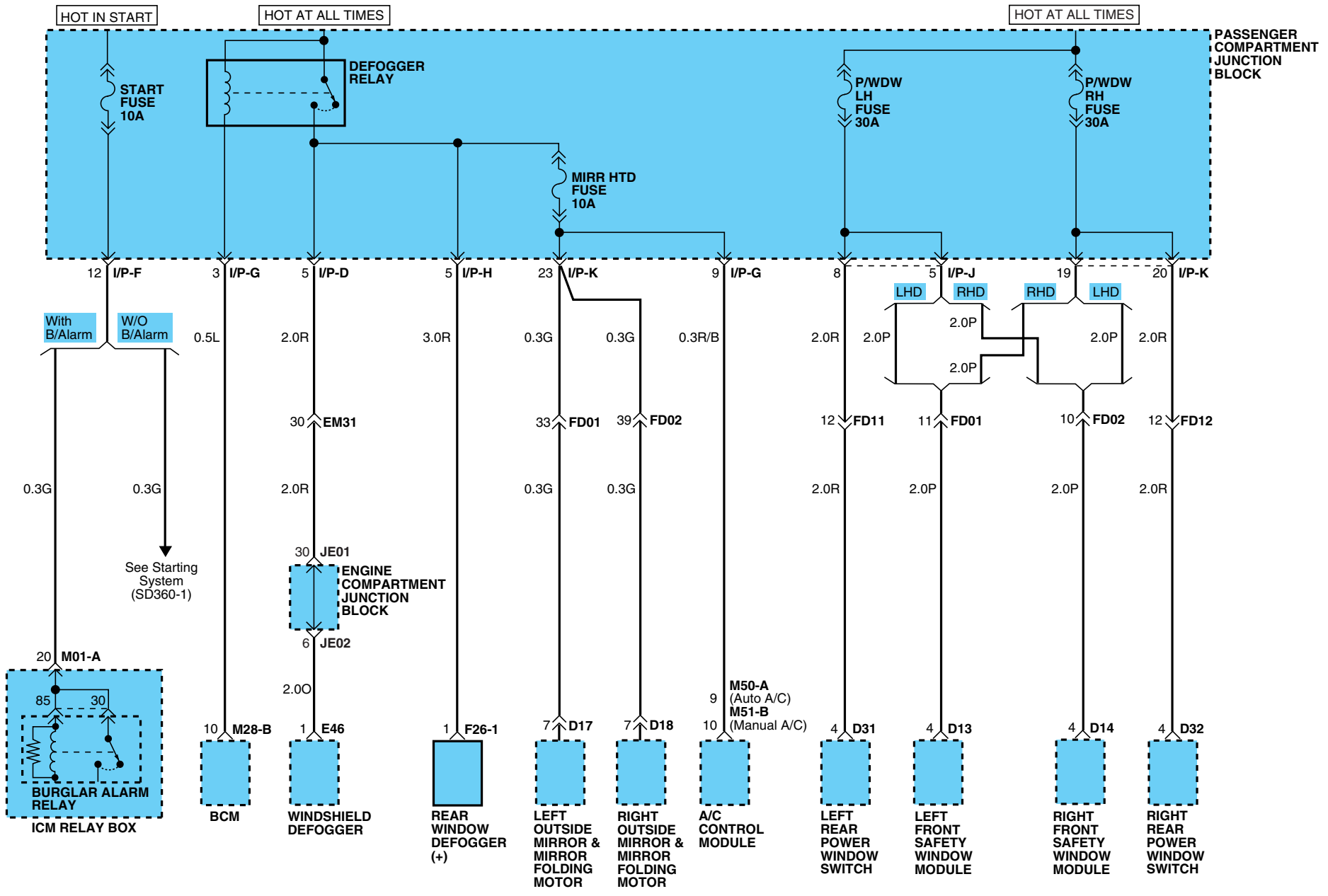



# PASSENGER COMPARTMENT FUSE DETAILS

## PASSENGER COMPARTMENT FUSE DETAILS (8)

SD120-8

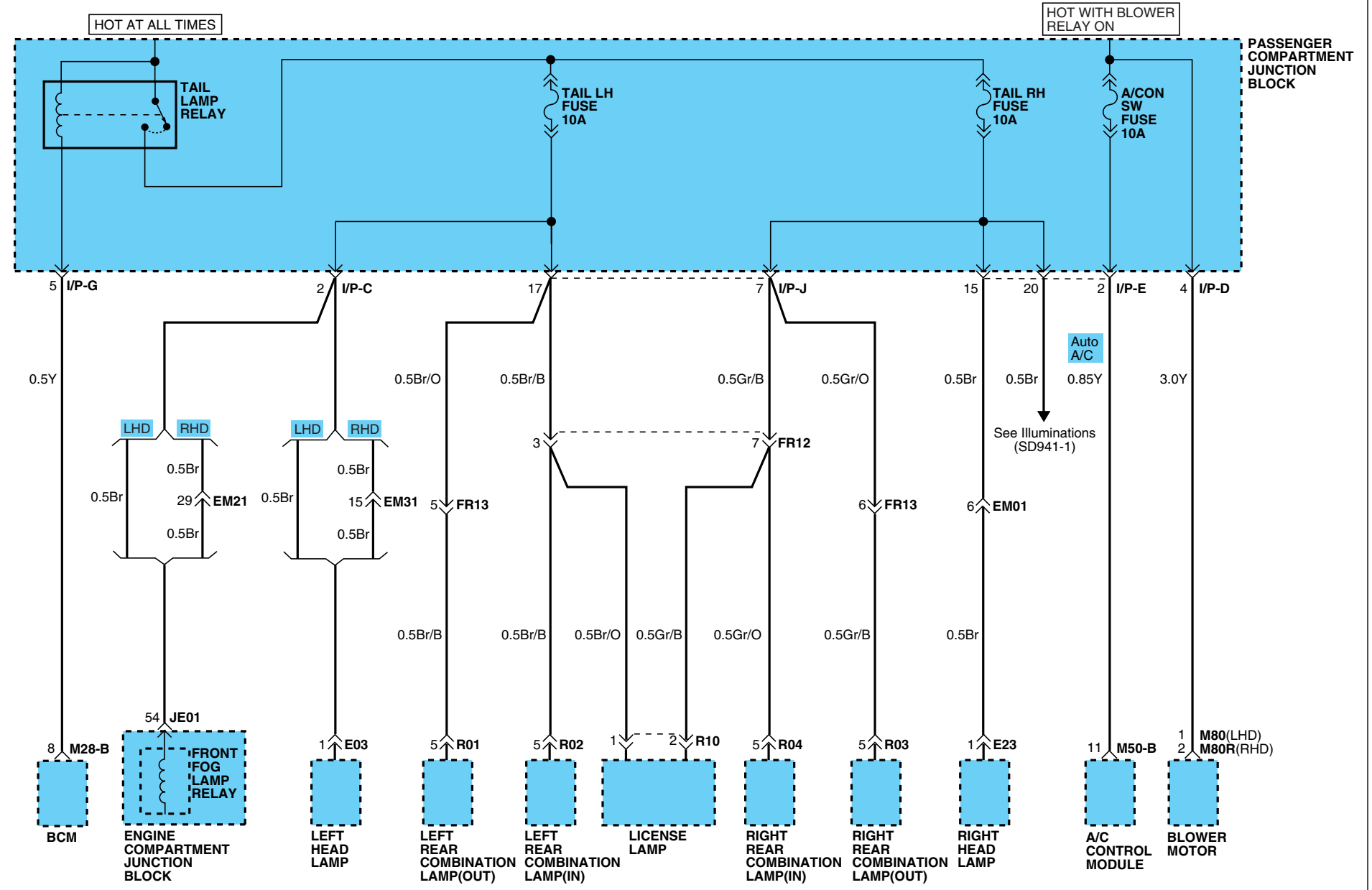

GROUND DISTRIBUTION (1)

SD130-1

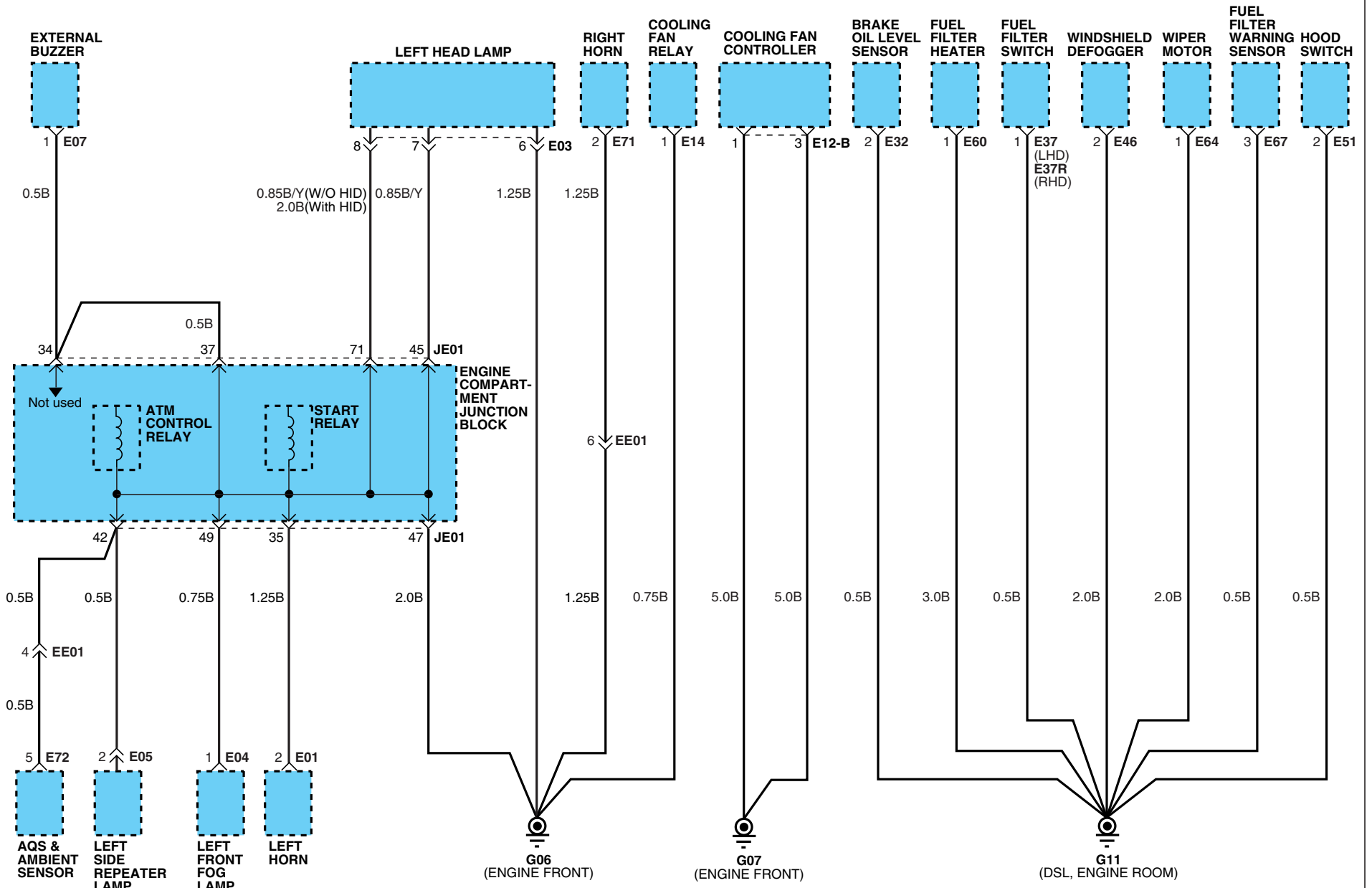

# GROUND DISTRIBUTION

## GROUND DISTRIBUTION (2)

SD130-2

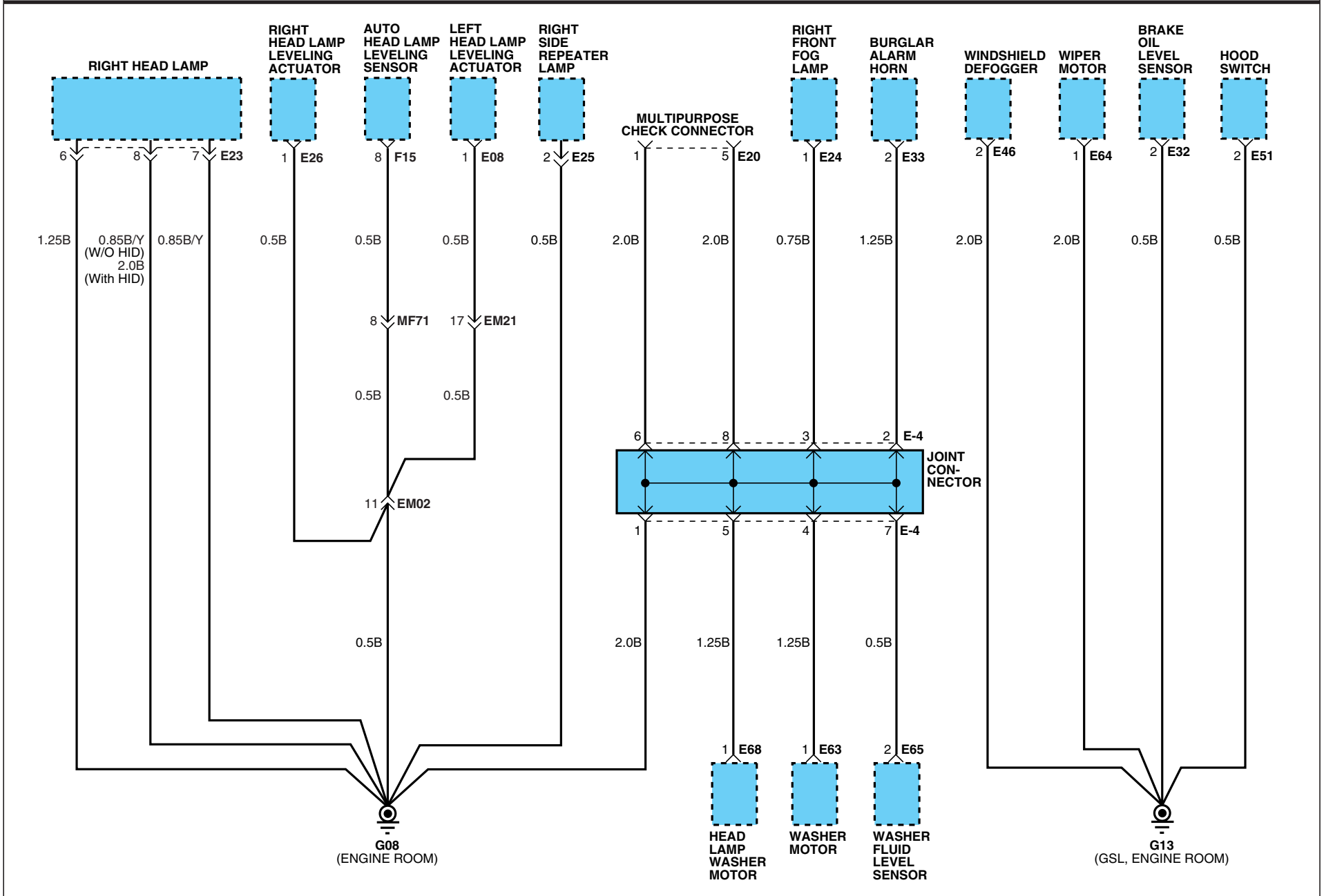

# GROUND DISTRIBUTION

## GROUND DISTRIBUTION (3)

SD130-3

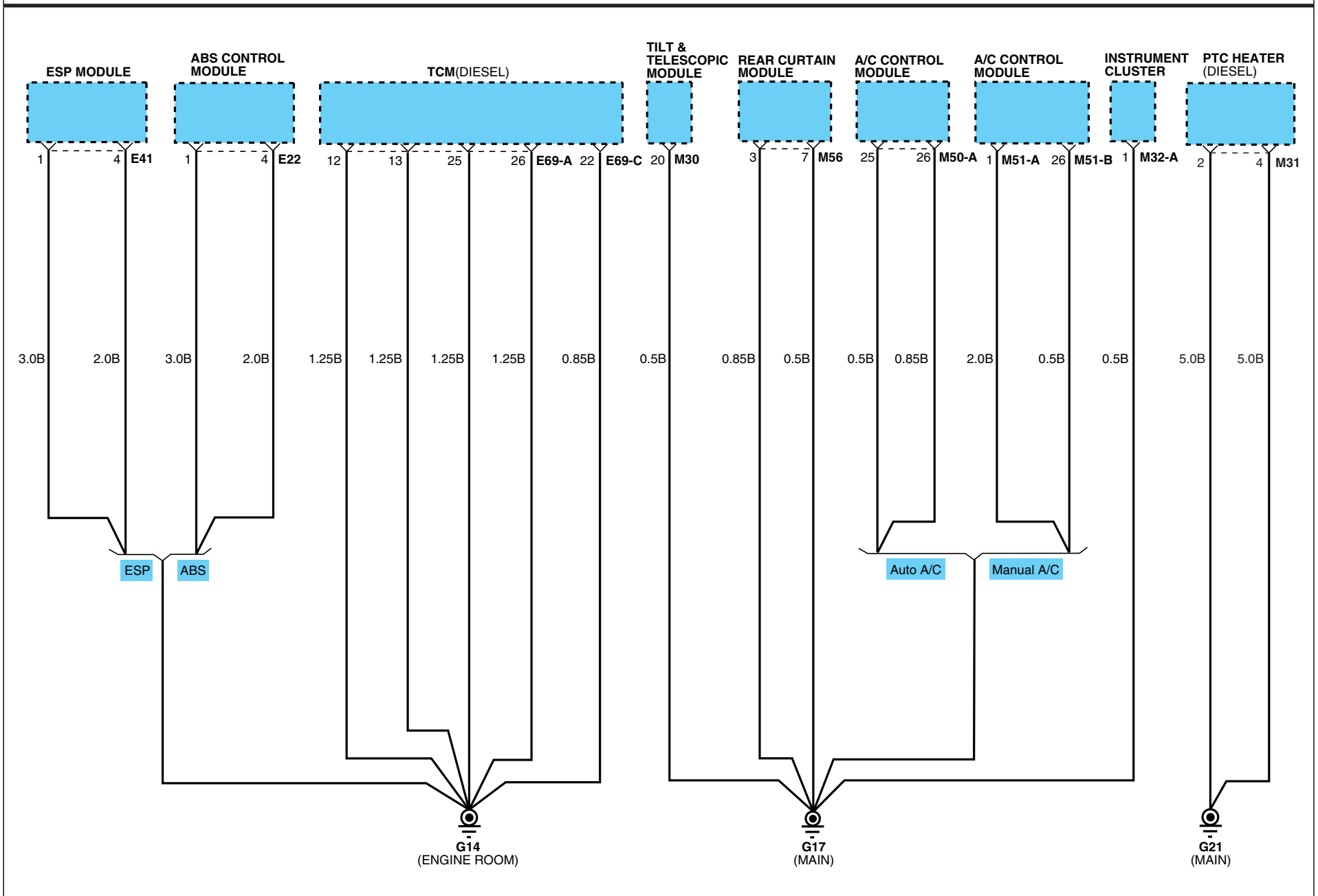

# GROUND DISTRIBUTION

## GROUND DISTRIBUTION (4)

SD130-4

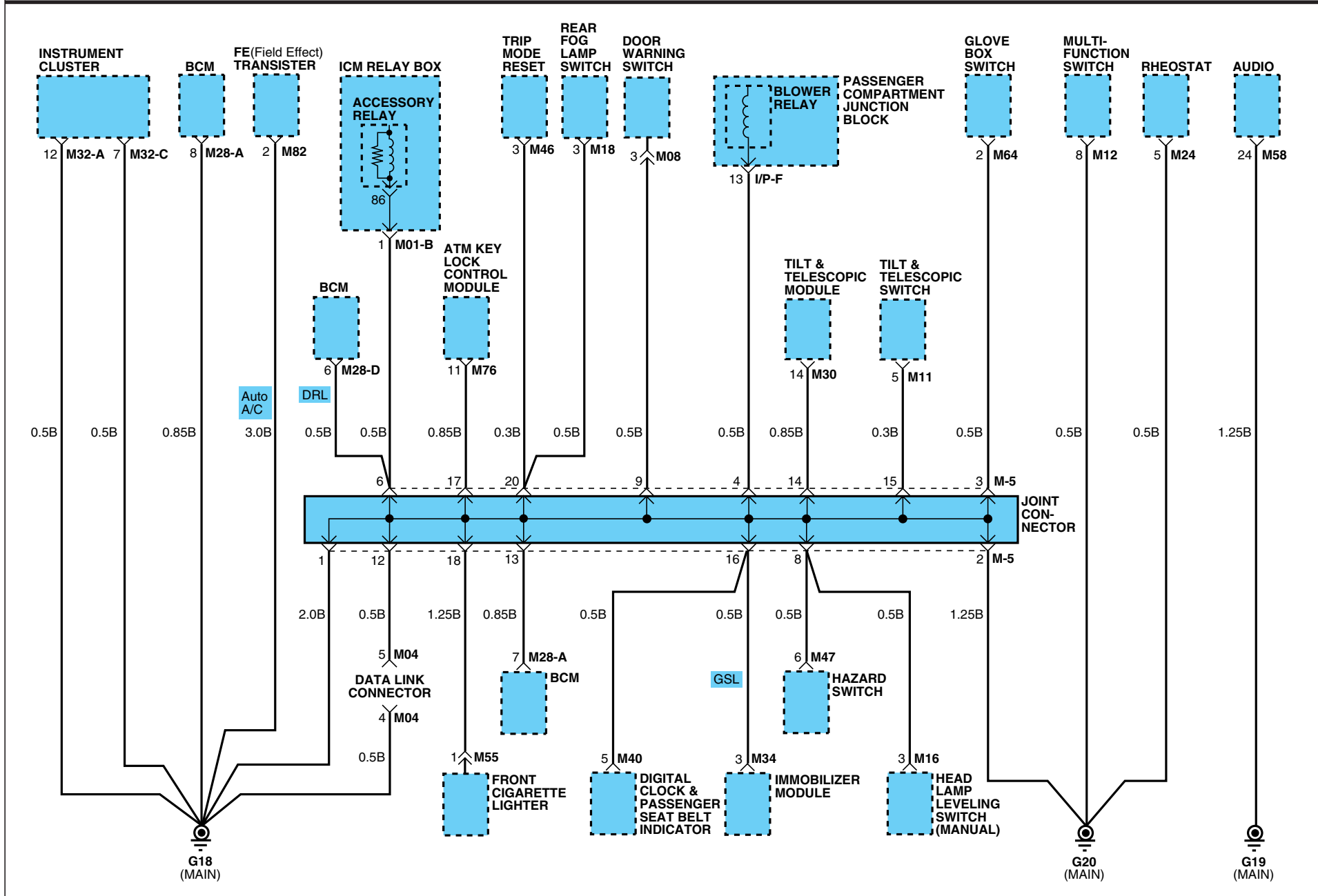

# GROUND DISTRIBUTION

## GROUND DISTRIBUTION (5)

SD130-5

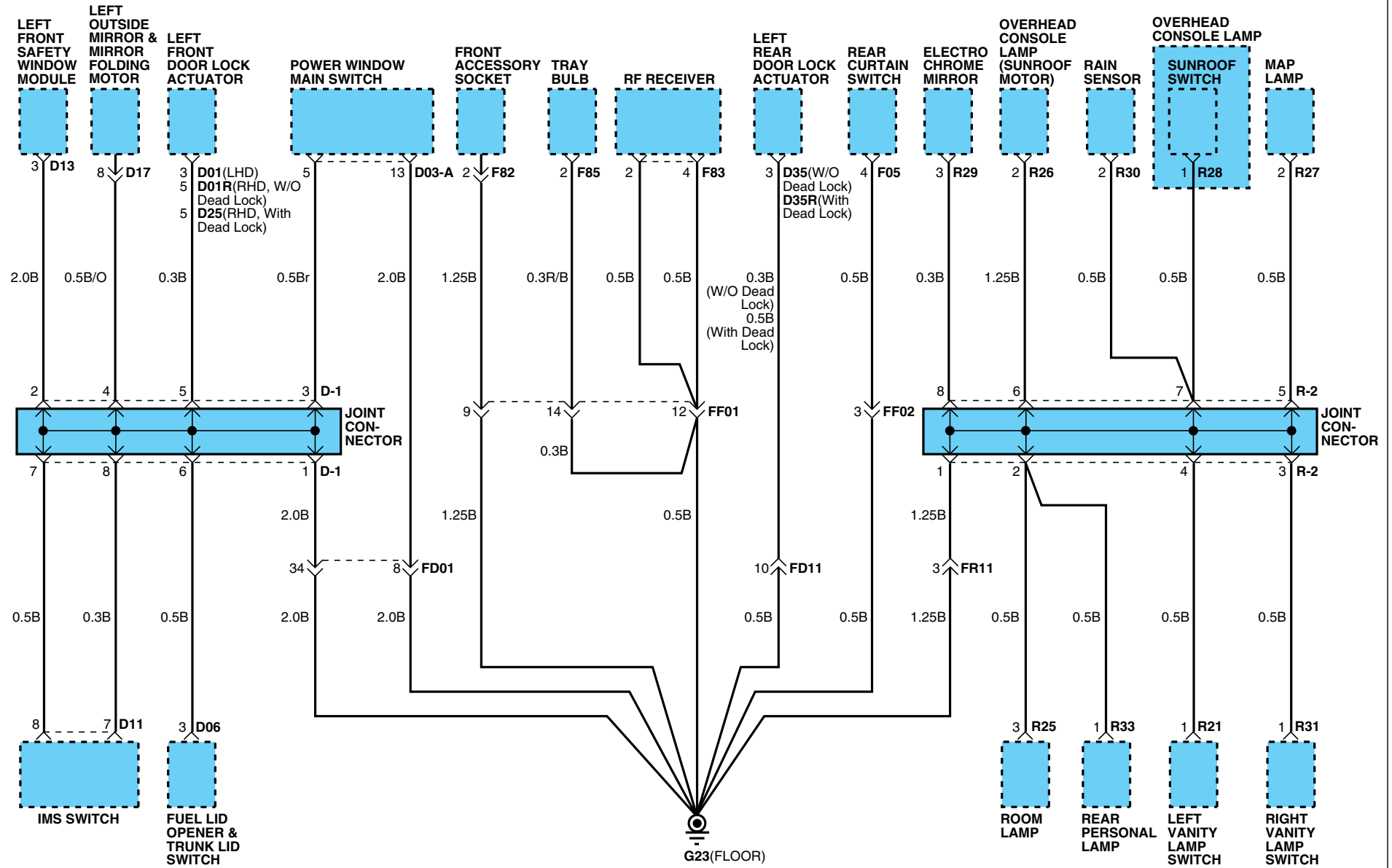

# GROUND DISTRIBUTION

## GROUND DISTRIBUTION (6)

SD130-6

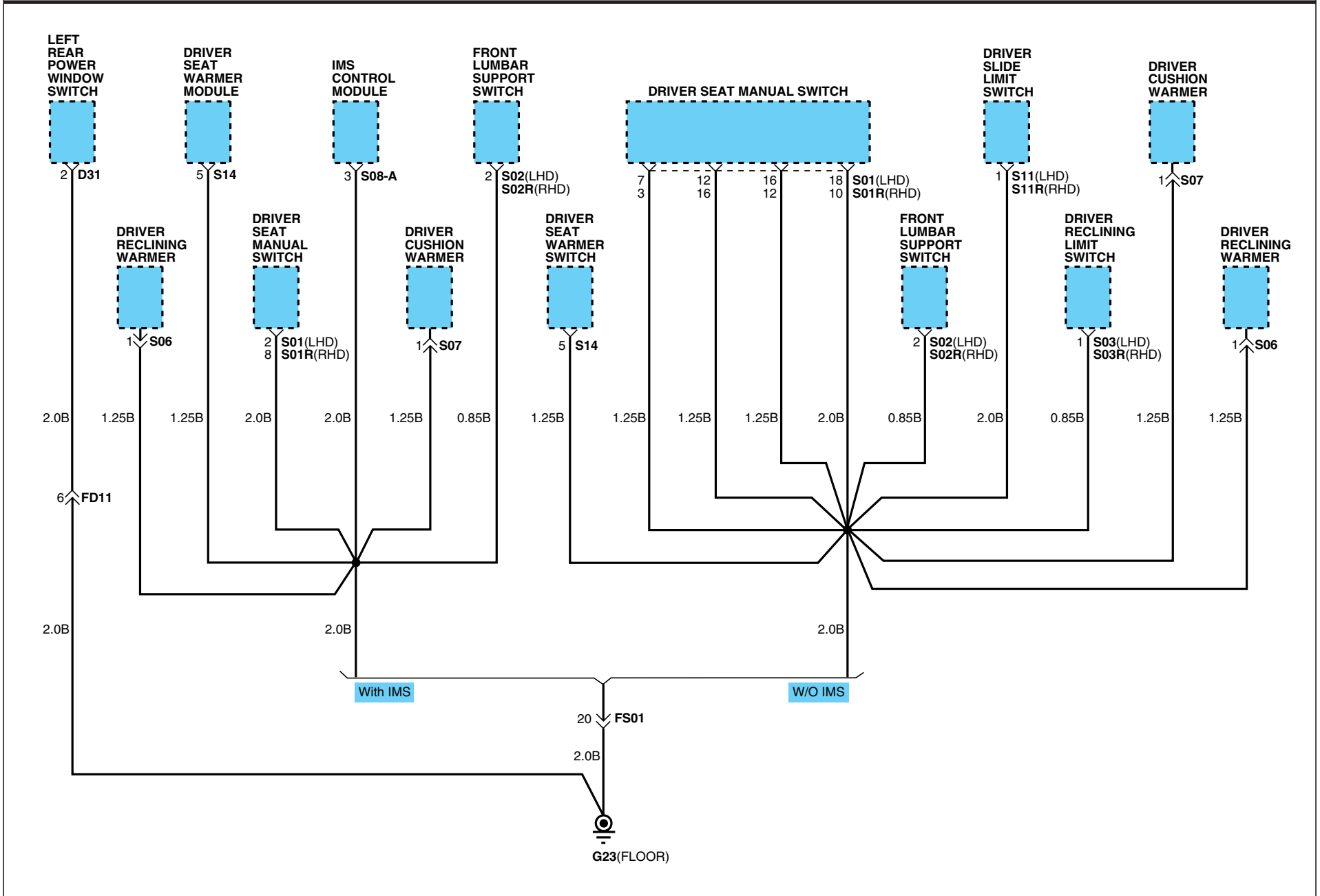

# GROUND DISTRIBUTION

## GROUND DISTRIBUTION (7)

SD130-7

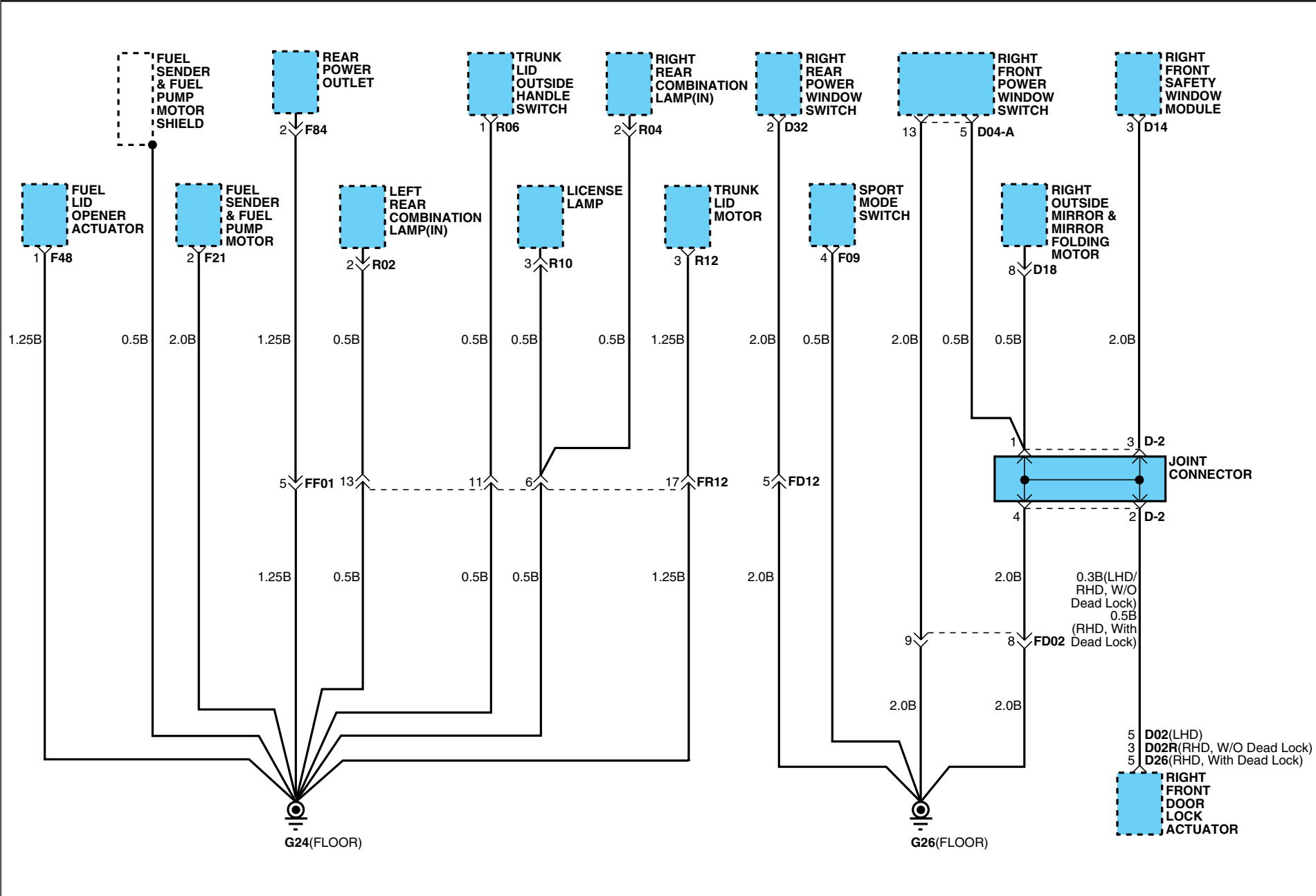



# GROUND DISTRIBUTION

## GROUND DISTRIBUTION (8)

SD130-8

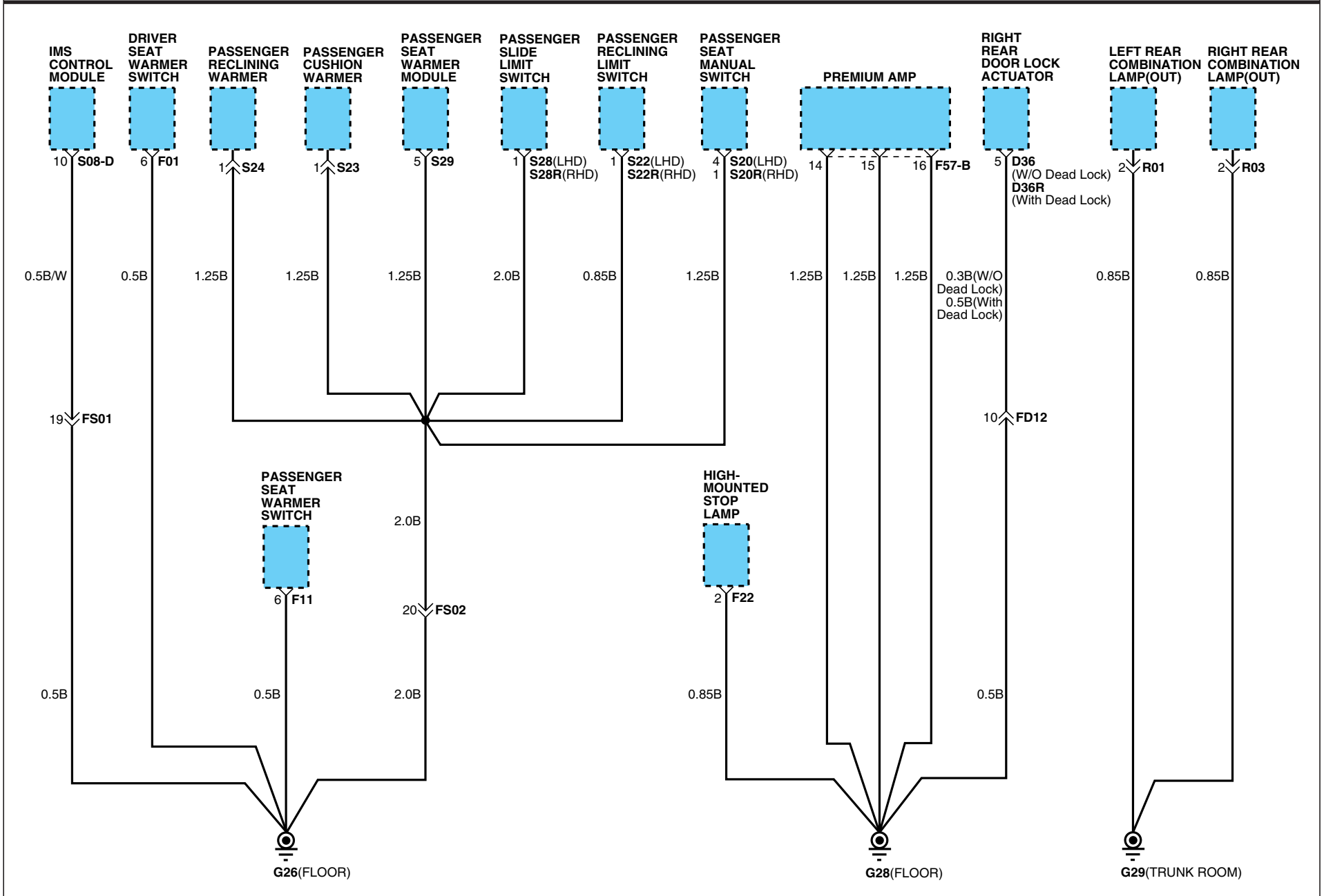

# GROUND DISTRIBUTION

## GROUND DISTRIBUTION (9)

SD130-9

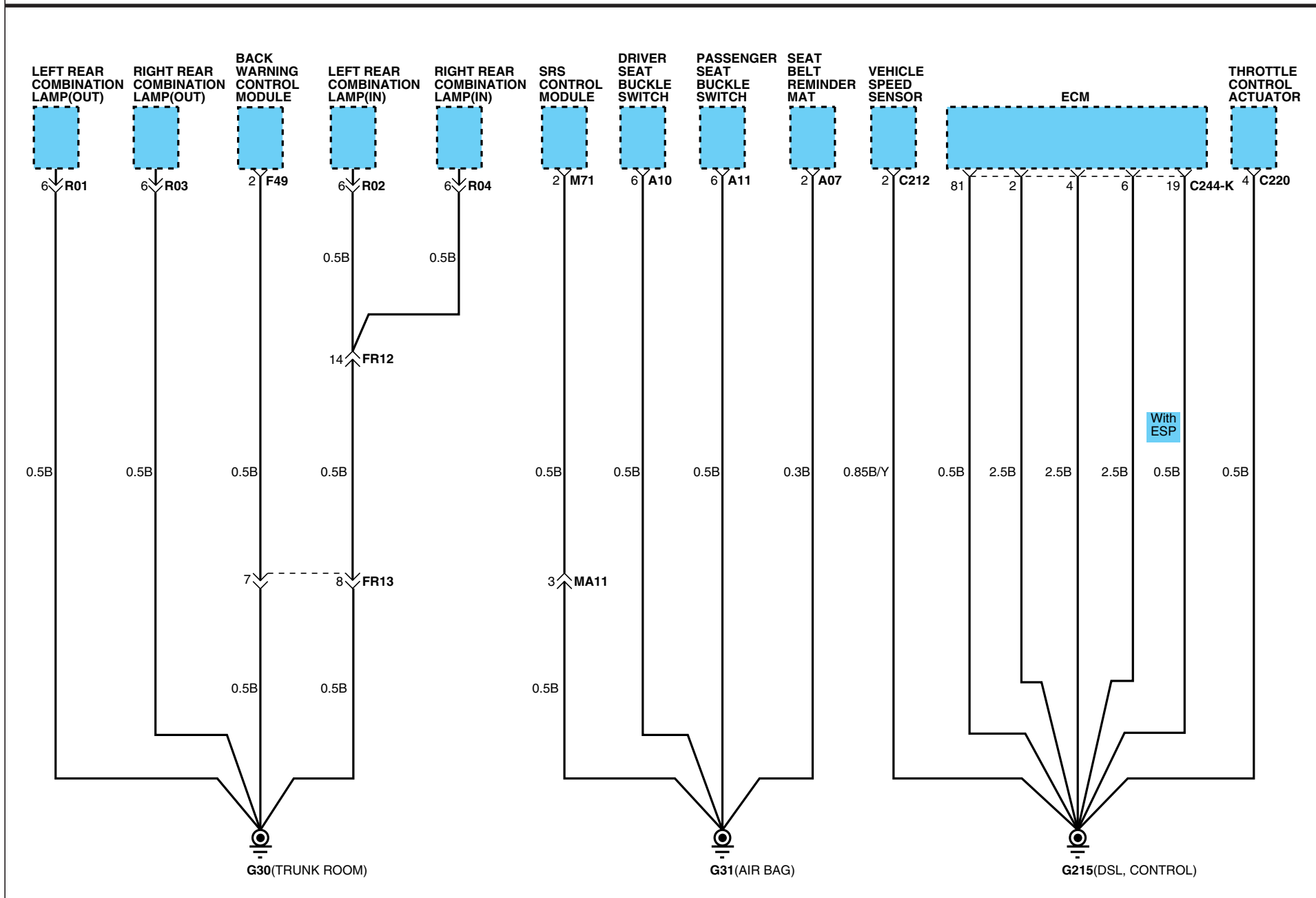

# GROUND DISTRIBUTION

## GROUND DISTRIBUTION (10)

SD130-10

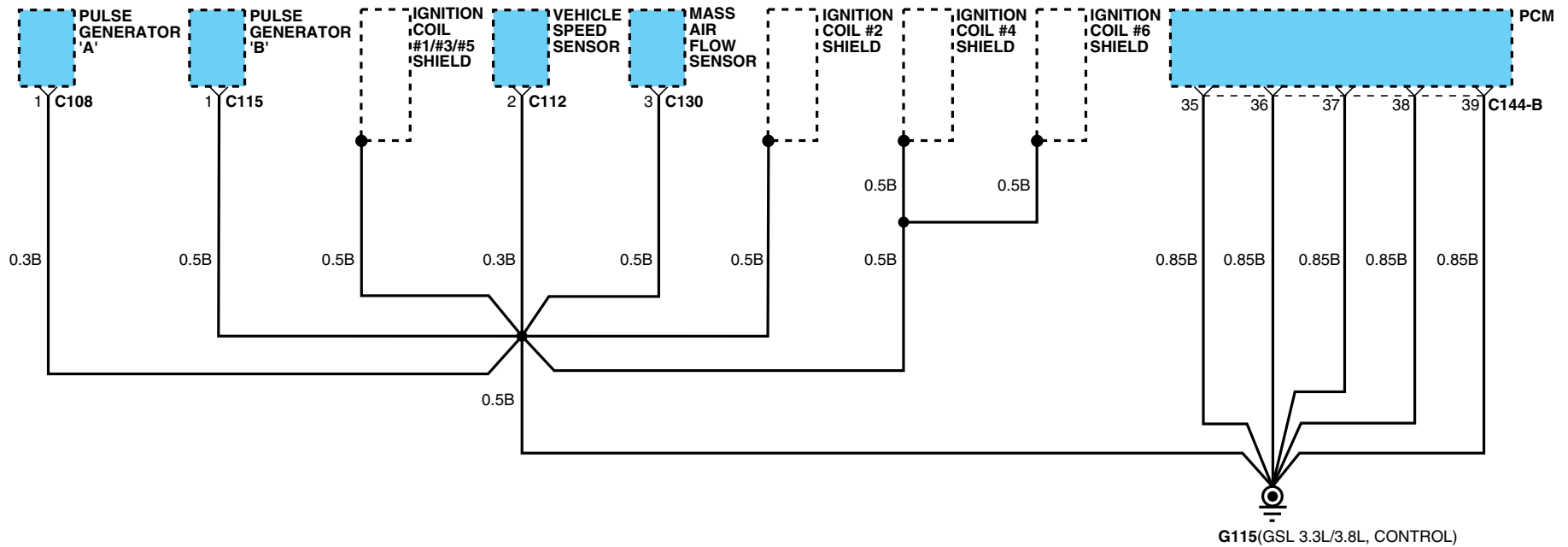
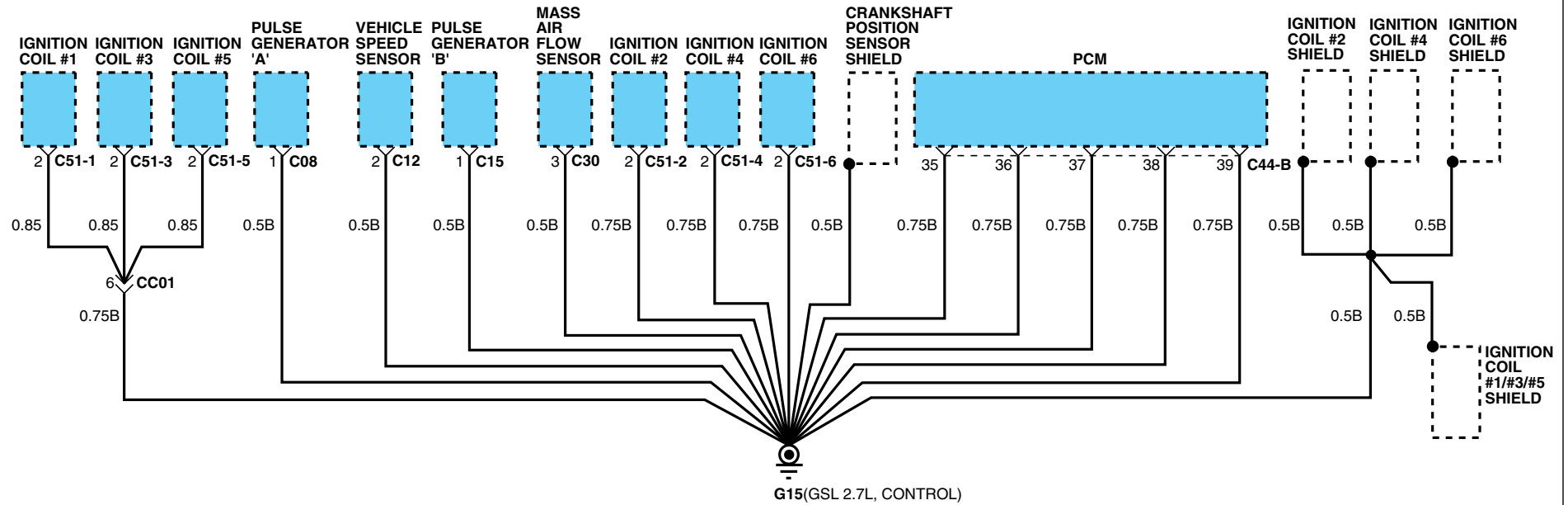

DATA LINK DETAILS (1)

SD200-1

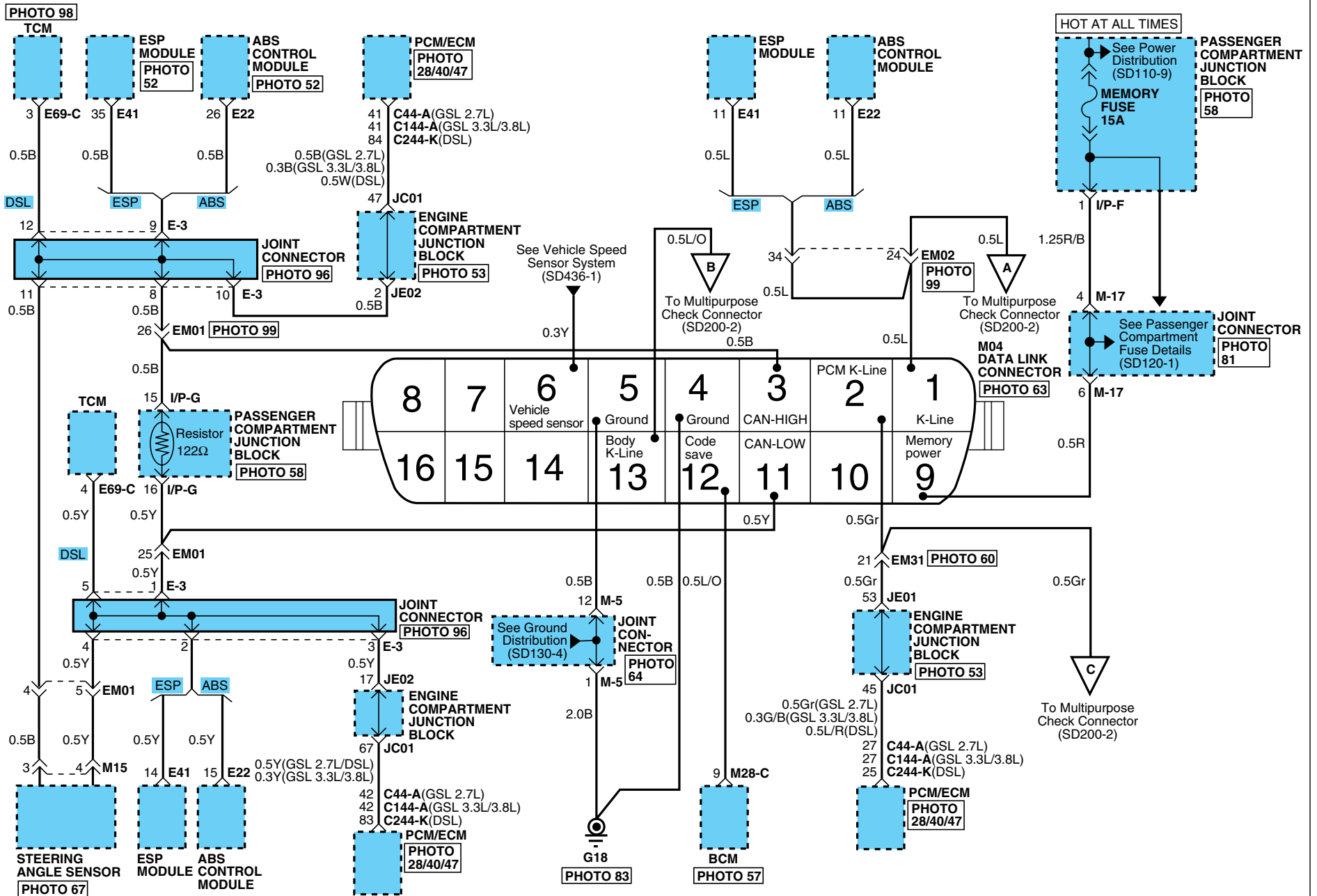

DATA LINK DETAILS

DATA LINK DETAILS (2)

SD200-2

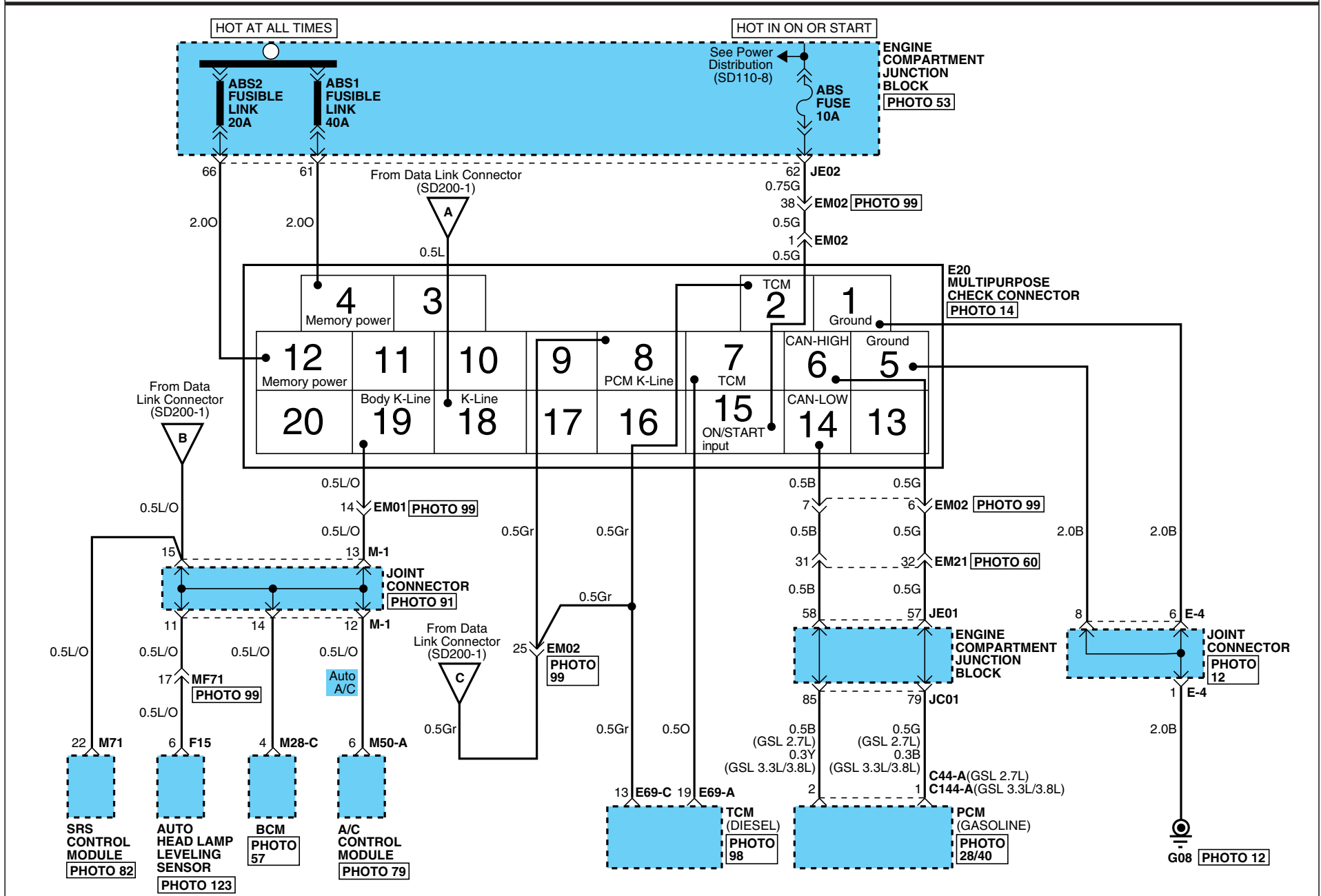

**DATA LINK DETAILS**

**DATA LINK DETAILS (3)**

**SD200-3**

**C44-A**

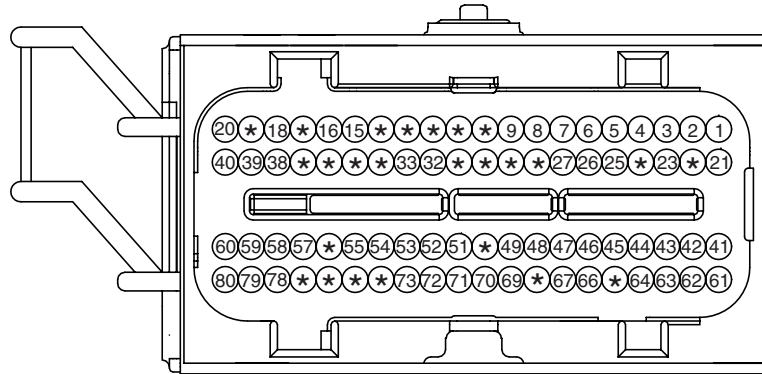

PKD\_ECU\_80F\_Gr\_1

**C144-A**

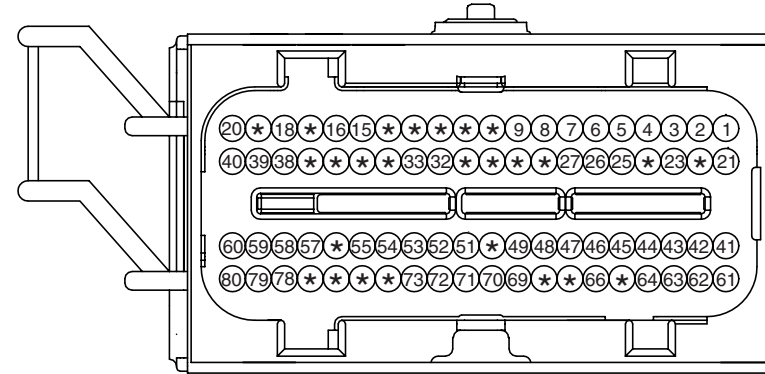

PKD\_ECU\_80F\_B\_1

**C244-K**

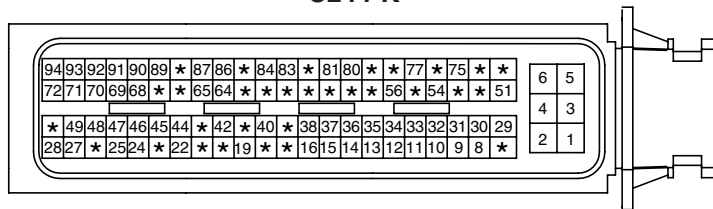

AMP\_ECU\_94F\_B

**E20**

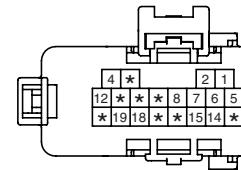

KET\_DIAG\_20F\_B\_BRK\_A

**E22**

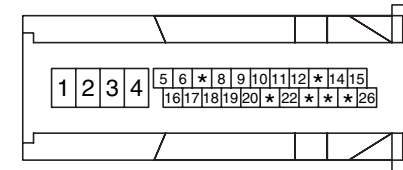

BOS\_ABS\_26F\_B\_L

**E41**

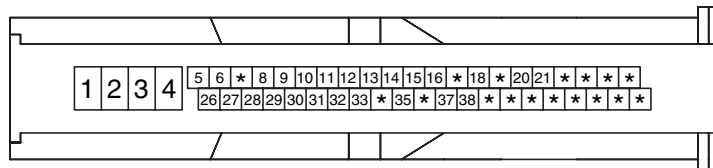

BOS\_ESP\_46F\_B\_L

**E69-A**

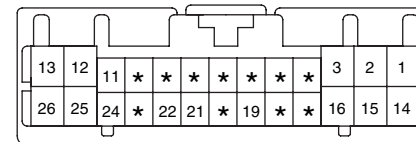

KET\_0407\_26F\_W

**E69-C**

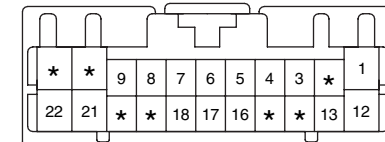

KET\_0407\_22F\_W

**F15**

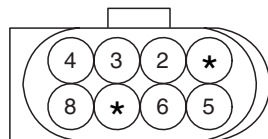

AMP\_DEV\_08F\_B

**M04**

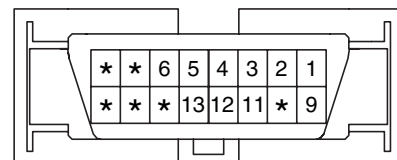

MLX\_OBDII\_16F\_B\_SIN

**M15**

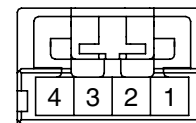

AMP\_MQS\_04F\_Y\_040

**M28-C**

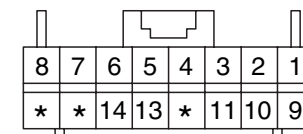

AMP\_0407\_16F\_W\_040

# DATA LINK DETAILS

## DATA LINK DETAILS (4)

SD200-4

M50-A

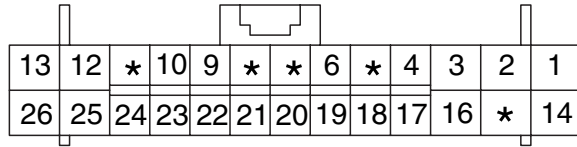

AMP\_0407\_26F\_W\_HD

M71

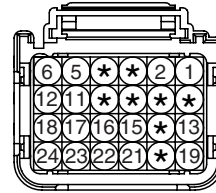

AMP\_ACU\_24F\_B

BLANK

COOLING SYSTEM (1)

SD253-1

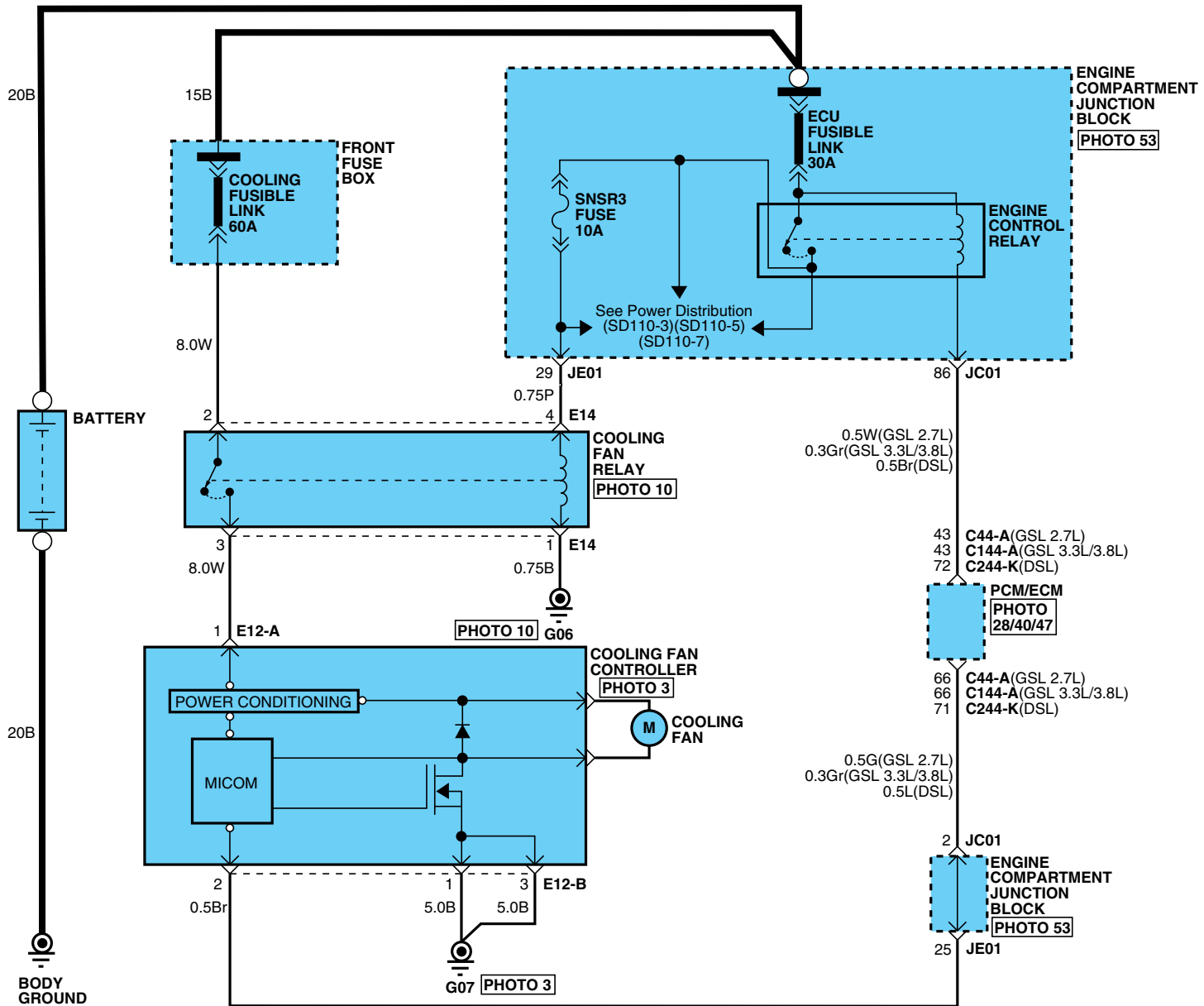



**COOLING SYSTEM**

**COOLING SYSTEM (2)**

**SD253-2**

**C44-A**

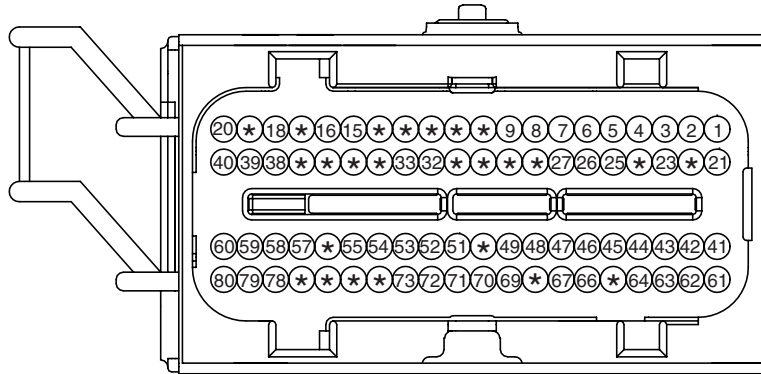

PKD\_ECU\_80F\_Gr\_1

**C144-A**

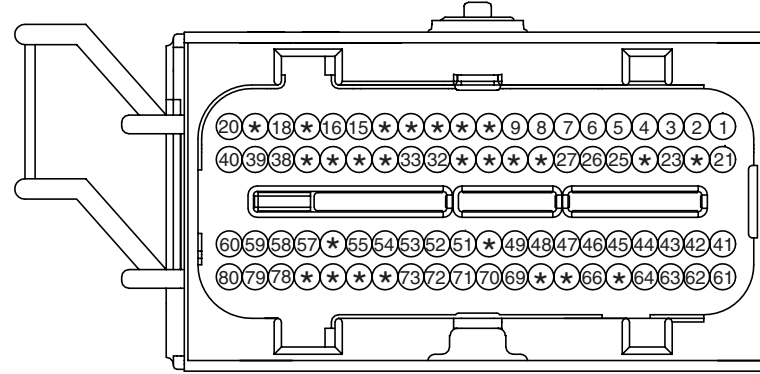

PKD\_ECU\_80F\_B\_1

**C244-K**

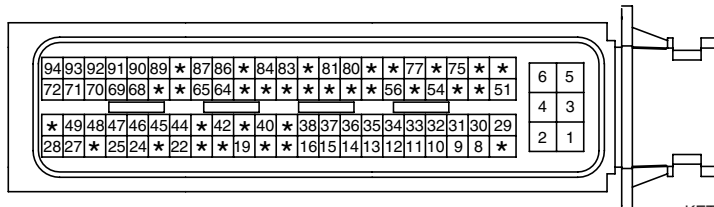

KET\_ECU\_94F\_B

**BLANK**

**BLANK**

**E12-A**



KET\_312IWP\_01F\_B

**E12-B**

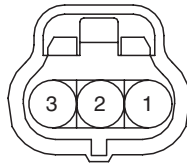

KET\_3118\_03F\_GR

**E14**

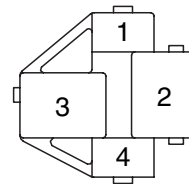

KET\_3725\_04F\_B

**BLANK**

MFI CONTROL SYSTEM (GSL 2.7L) (1)

SD313-1

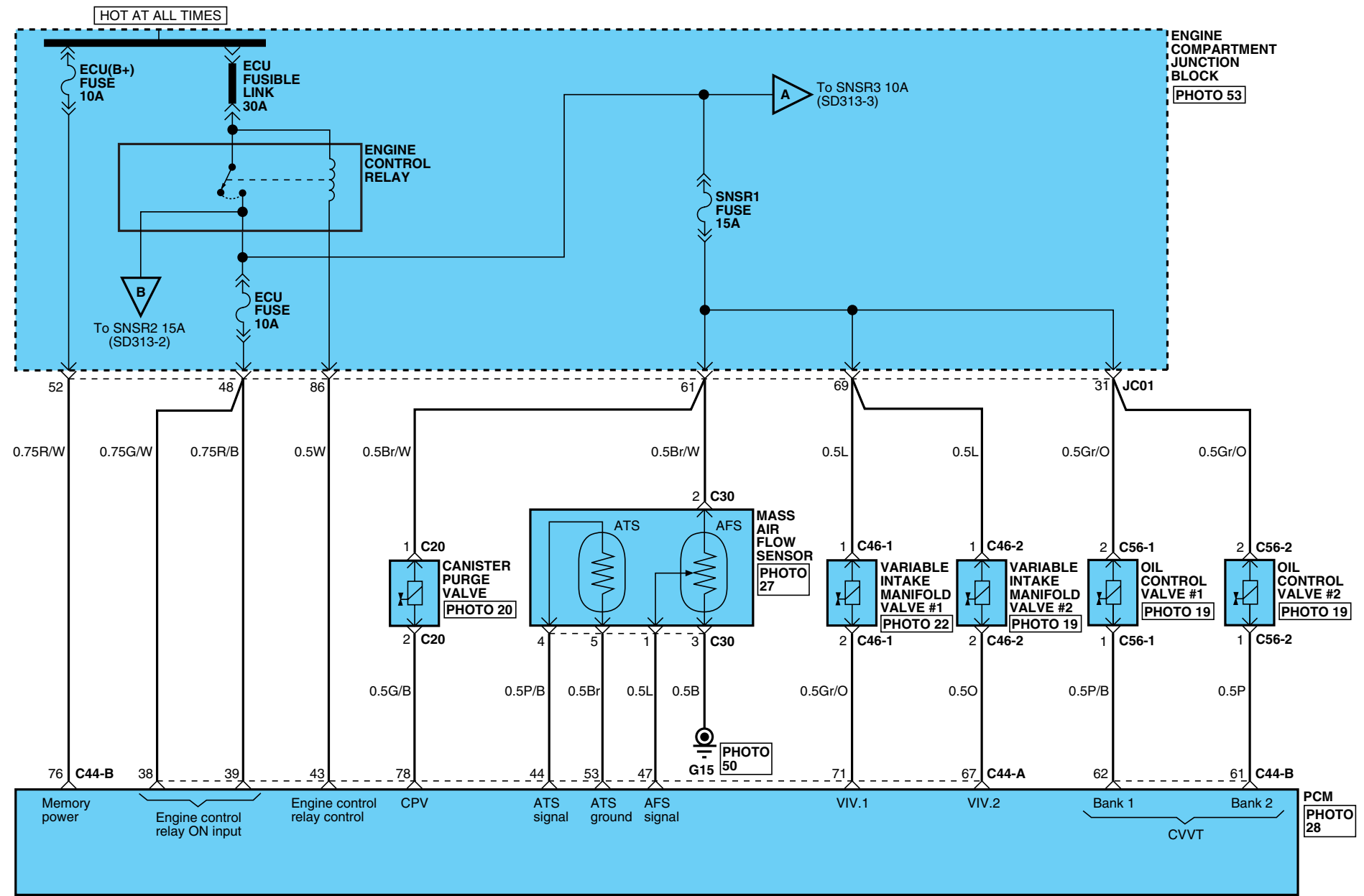

# MFI CONTROL SYSTEM

## MFI CONTROL SYSTEM (GSL 2.7L) (2)

SD313-2

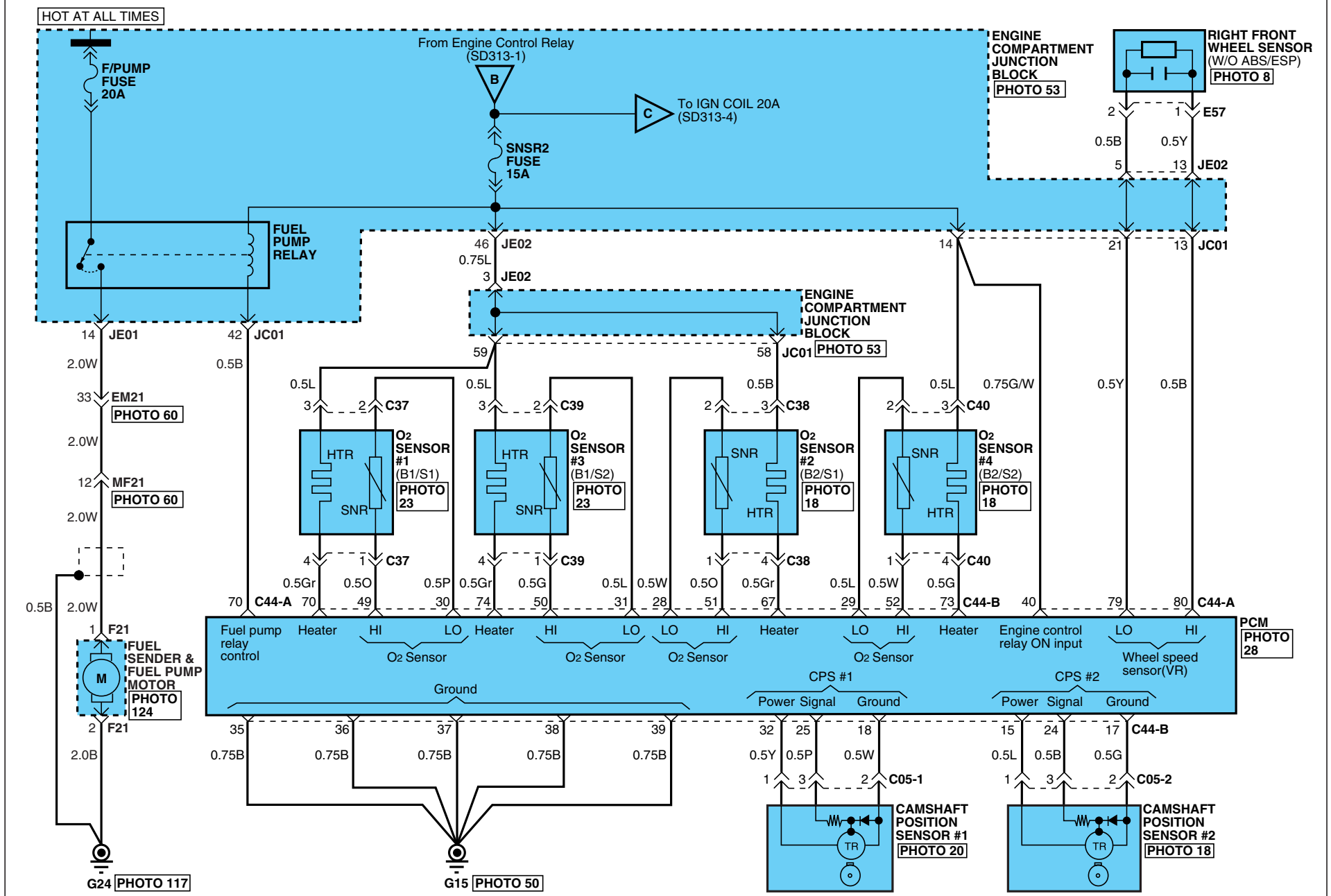

# MFI CONTROL SYSTEM

## MFI CONTROL SYSTEM (GSL 2.7L) (3)

SD313-3

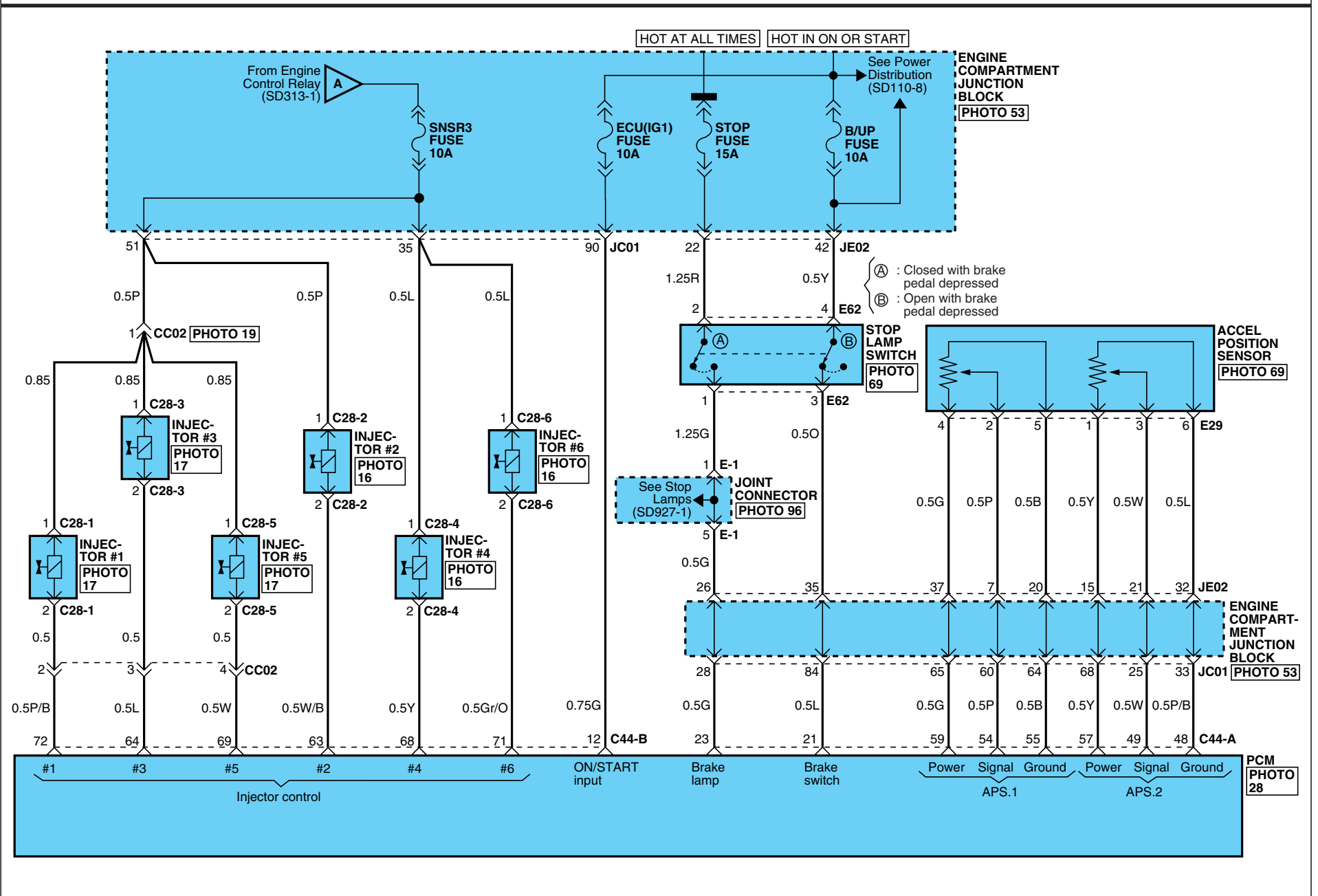

# MFI CONTROL SYSTEM

## MFI CONTROL SYSTEM (GSL 2.7L) (4)

SD313-4

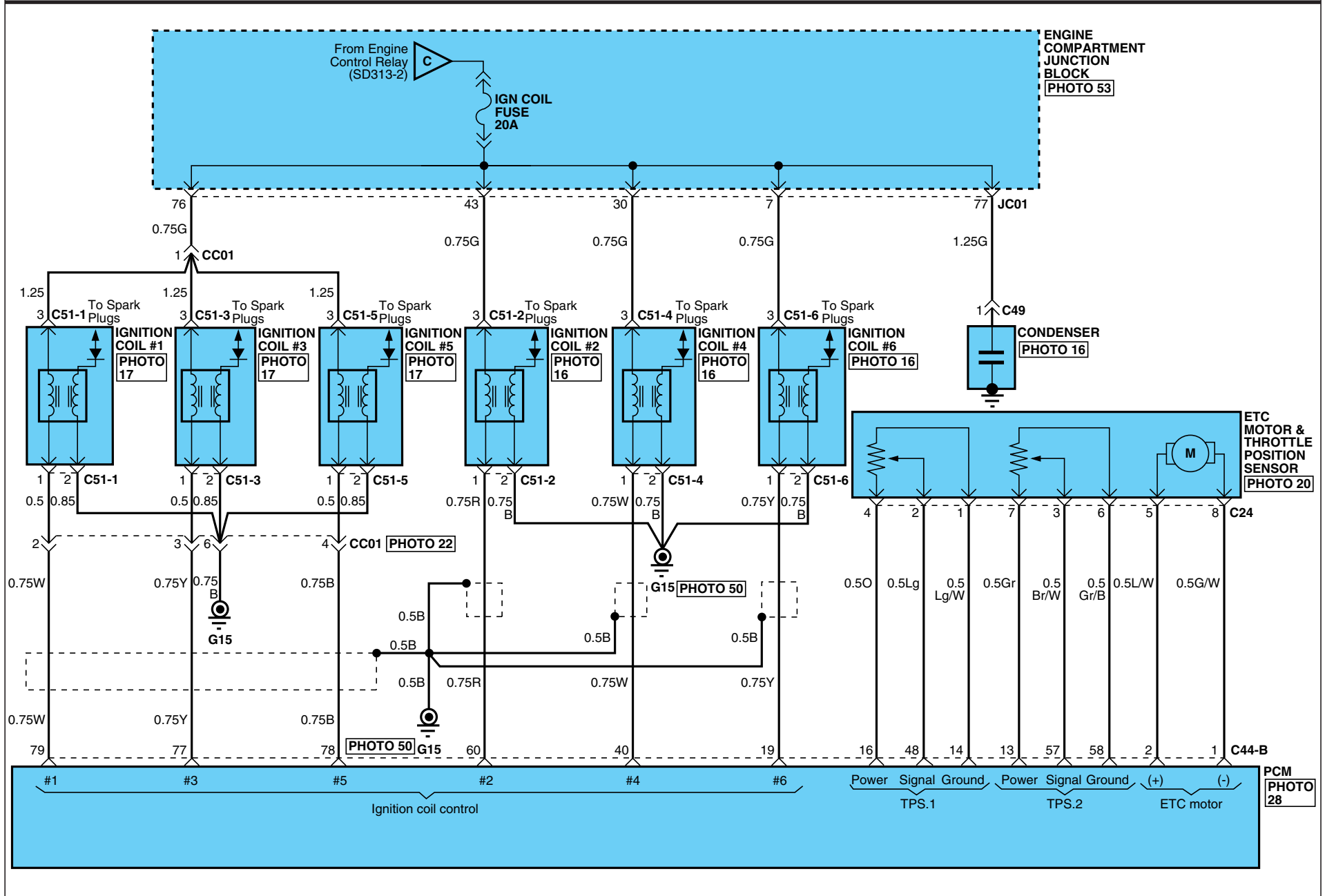

MFI CONTROL SYSTEM

MFI CONTROL SYSTEM (GSL 2.7L) (5)

SD313-5

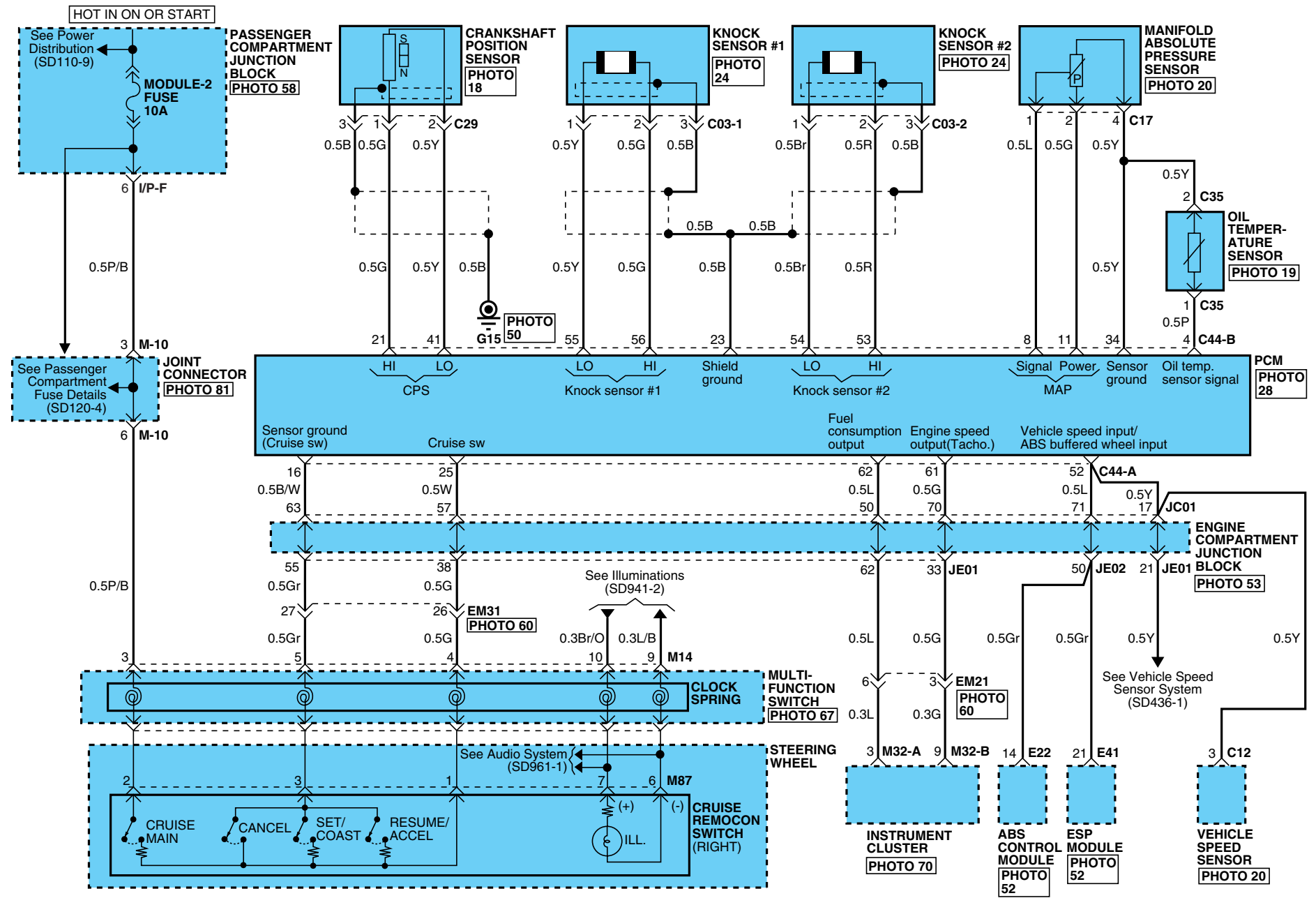

# MFI CONTROL SYSTEM

## MFI CONTROL SYSTEM (GSL 2.7L) (6)



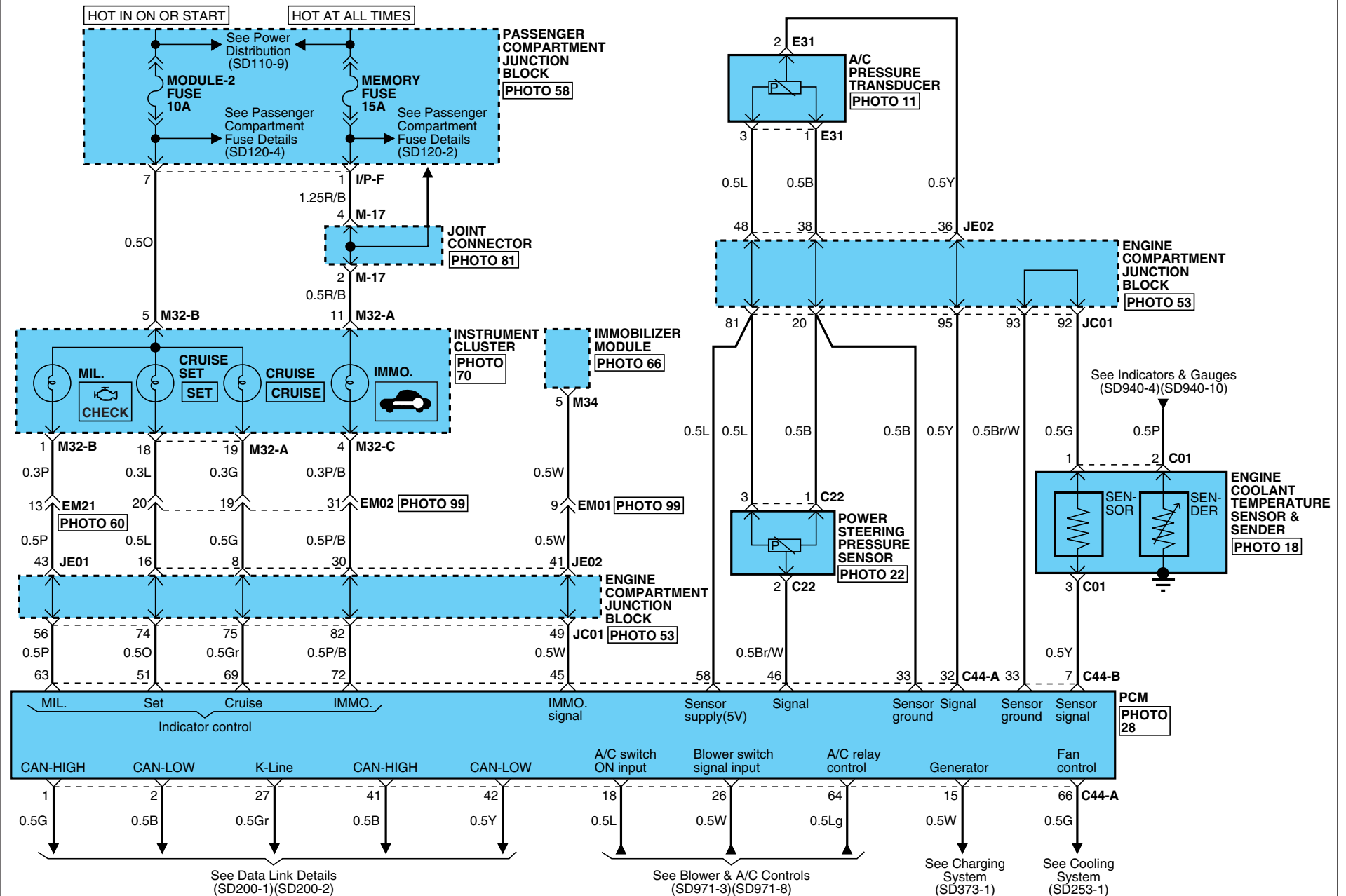



SD313-6

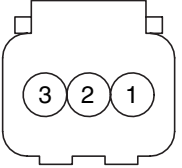
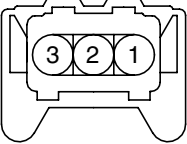
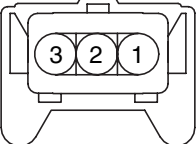
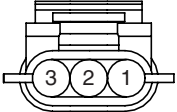
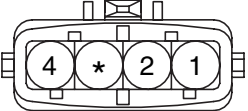

# MFI CONTROL SYSTEM

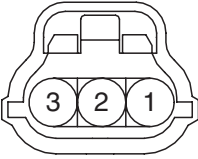
## MFI CONTROL SYSTEM (GSL 2.7L) (7)

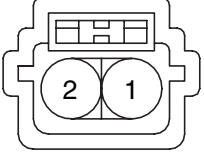
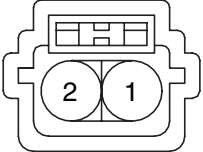
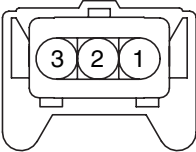
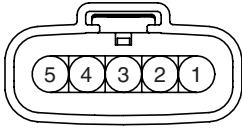
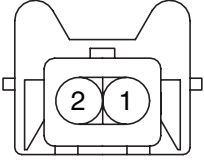
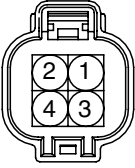
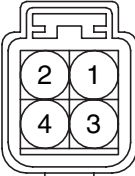
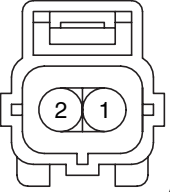
SD313-7

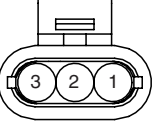
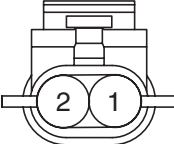
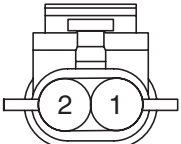
<p><b>C01</b></p>  <p>KUM_WTS_03F_B</p>	<p><b>C03-1</b></p>  <p>AMP_JPT_03F_Gr_R2</p>	<p><b>C03-2</b></p>  <p>AMP_JPT_03F_B_S2</p>	<p><b>C05-1,2</b></p>  <p>PKD_150WP_03F_B_L</p>
<p><b>C17</b></p>  <p>AMP_JPT_04F_B_BOSCH</p>	<p><b>C20</b></p>  <p>AMP_2.8WP_02F_B</p>	<p><b>C22</b></p>  <p>YAZ_040WP_03F_B</p>	<p><b>C24</b></p>  <p>PKD_GT150_08F_B</p>
<p><b>C28-1,3,5</b></p>  <p>KUM_NDWP_02F_B</p>	<p><b>C28-2,4,6</b></p>  <p>KUM_NDWP_02F_B</p>	<p><b>C29</b></p>  <p>AMP_JPT_03F_B_S1</p>	<p><b>C30</b></p>  <p>PKD_GT150_05F_B</p>
<p><b>C35</b></p>  <p>AMP_JPT_02F_B</p>	<p><b>C37/C38</b></p>  <p>KUM_KMWP_04F_B</p>	<p><b>C39/C40</b></p>  <p>KUM_NMWP_04F_Gr</p>	<p><b>C46-1,2</b></p>  <p>AMP_EJWP_02F_B</p>
<p><b>C49</b></p>  <p>KET_58X_01F_B</p>	<p><b>C51-1,2,3,4,5,6</b></p>  <p>AMP_1.5WP_03F_B</p>	<p><b>C56-1</b></p>  <p>PKD_GT150_02F_Gr</p>	<p><b>C56-2</b></p>  <p>PKD_GT150_02F_B</p>



**MFI CONTROL SYSTEM**

**MFI CONTROL SYSTEM (GSL 2.7L) (8)**

**SD313-8**

**C44-A**

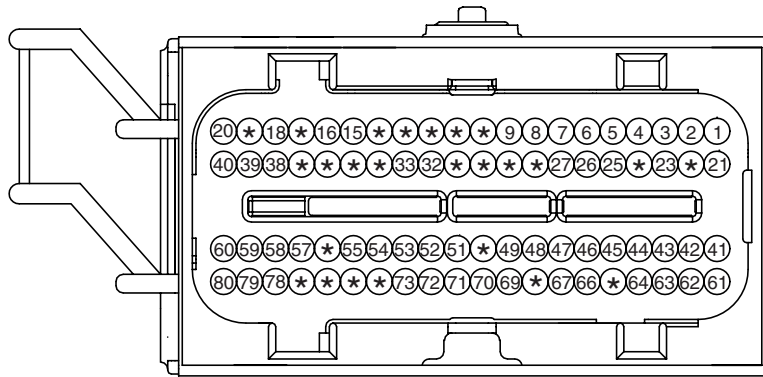

PKD\_ECU\_80F\_Gr\_1

**C44-B**

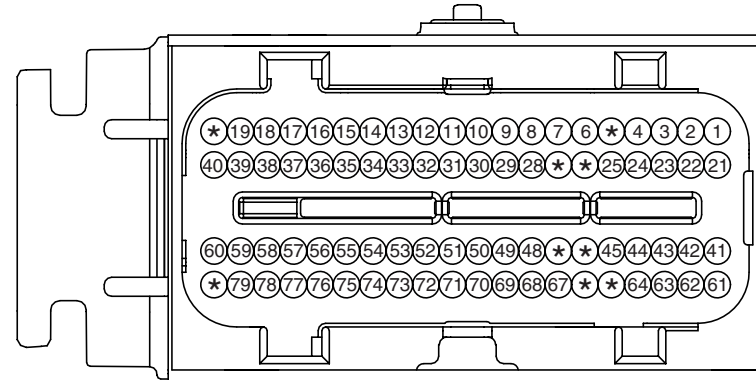

PKD\_ECU\_80F\_B\_2

**BLANK**

**E29**

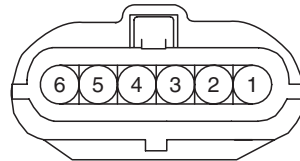

AMP\_070WP\_06F\_B

**E31**

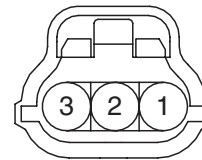

YAZ\_040WP\_03F\_B

**E57**

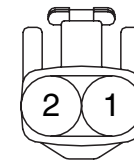

KET\_090IWP\_02F\_B

**E62**

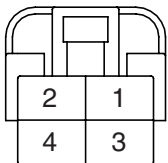

KET\_250DL\_04F\_W

**F21**

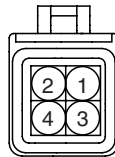

AMP\_MCP\_E\_04F\_B

**M14**

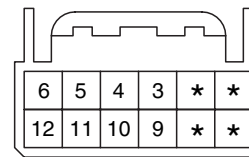

AMP\_025\_12F\_W

**M32-A**

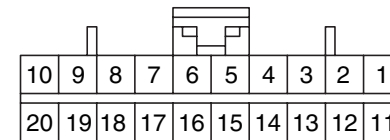

AMP\_040M2\_20F\_B

**M32-B**

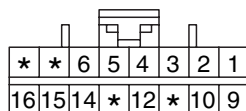

AMP\_040M2\_16F\_B

**M32-C**

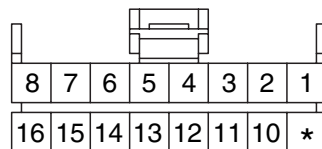

AMP\_040M1\_16F\_B

**M87**

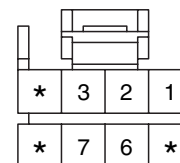

AMP\_040M1\_08F\_B

**BLANK**

MFI CONTROL SYSTEM (GSL 3.3L/3.8L) (1)

SD313-9

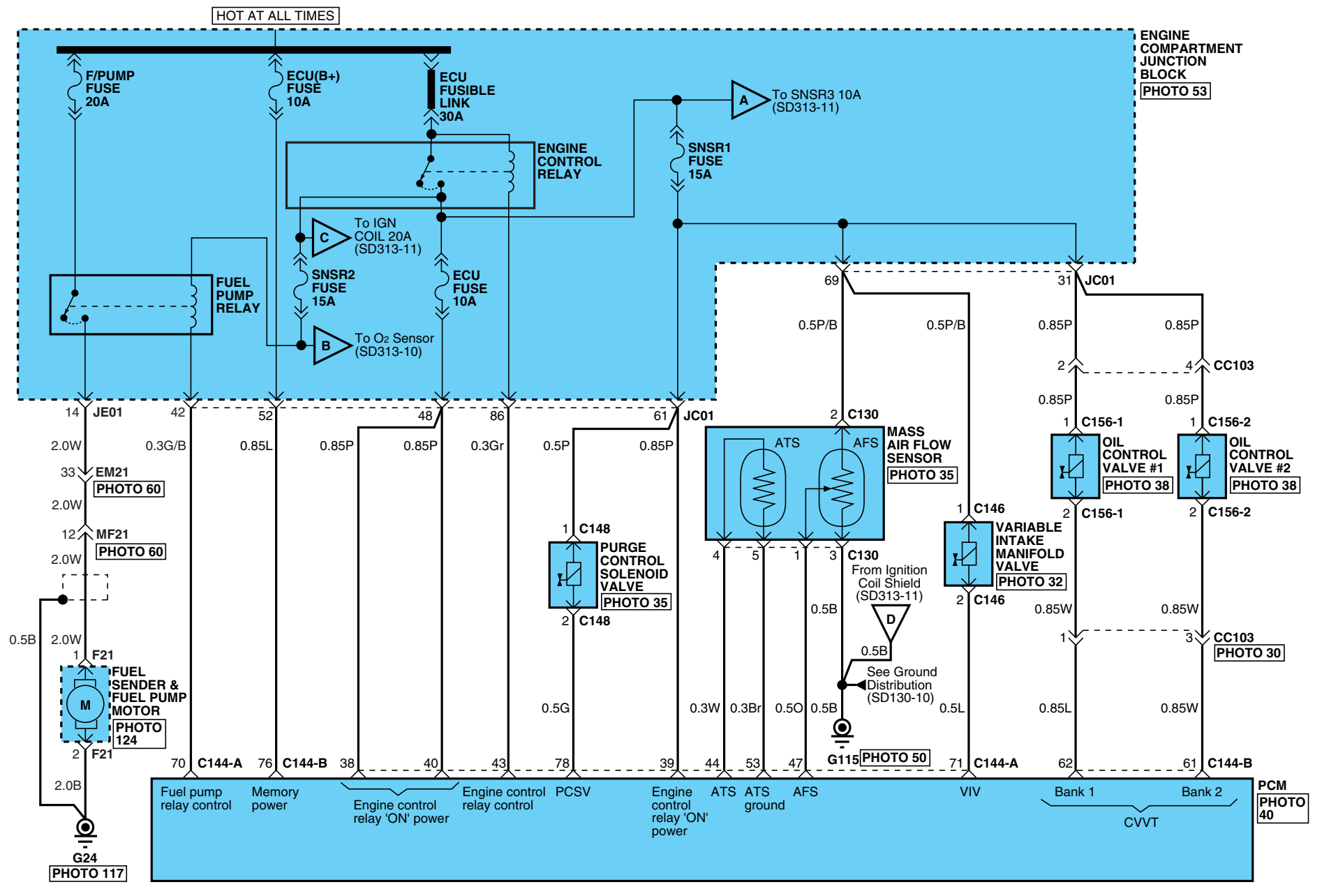

# MFI CONTROL SYSTEM

## MFI CONTROL SYSTEM (GSL 3.3L/3.8L) (2)

SD313-10

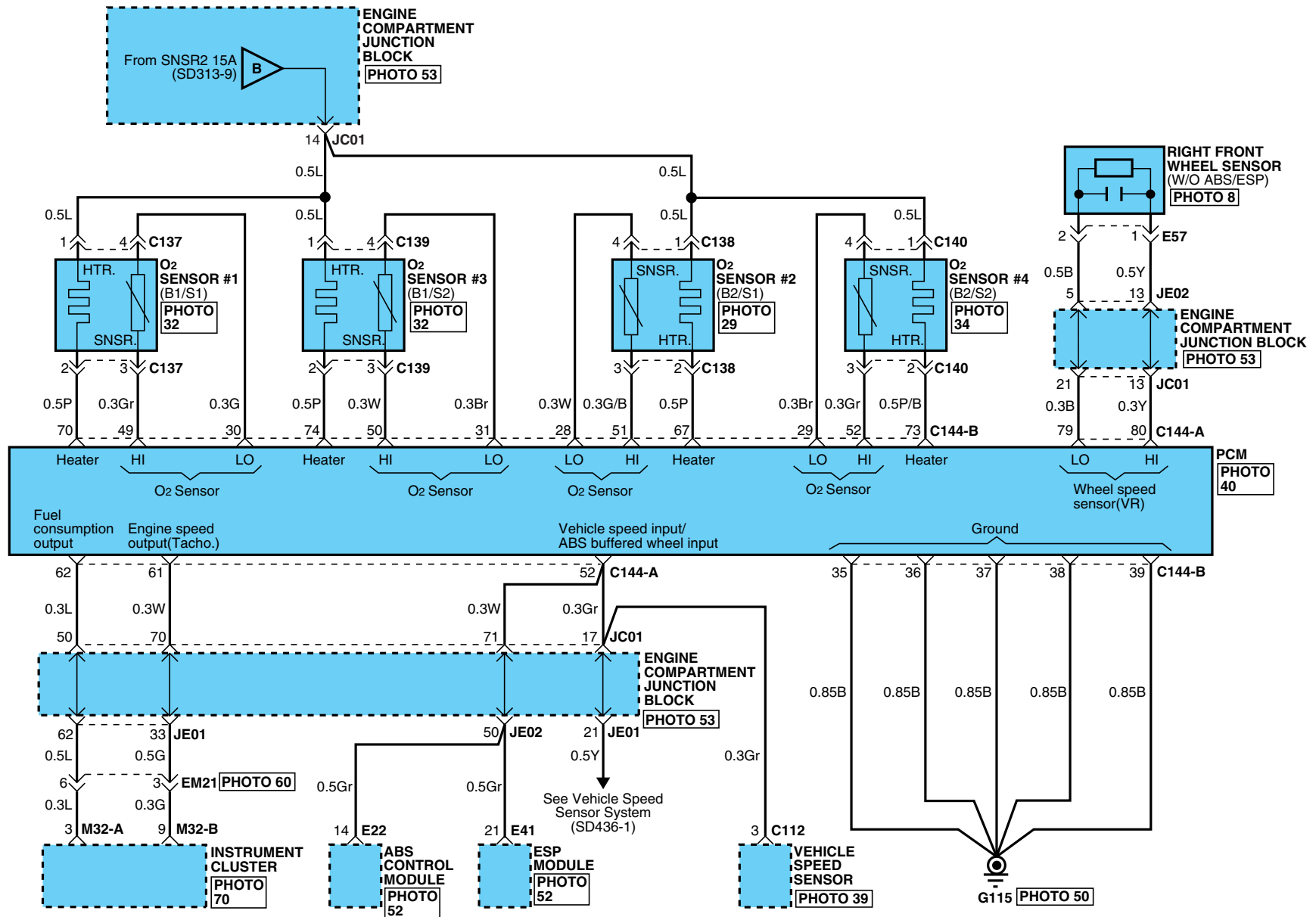

# MFI CONTROL SYSTEM

## MFI CONTROL SYSTEM (GSL 3.3L/3.8L) (3)

SD313-11

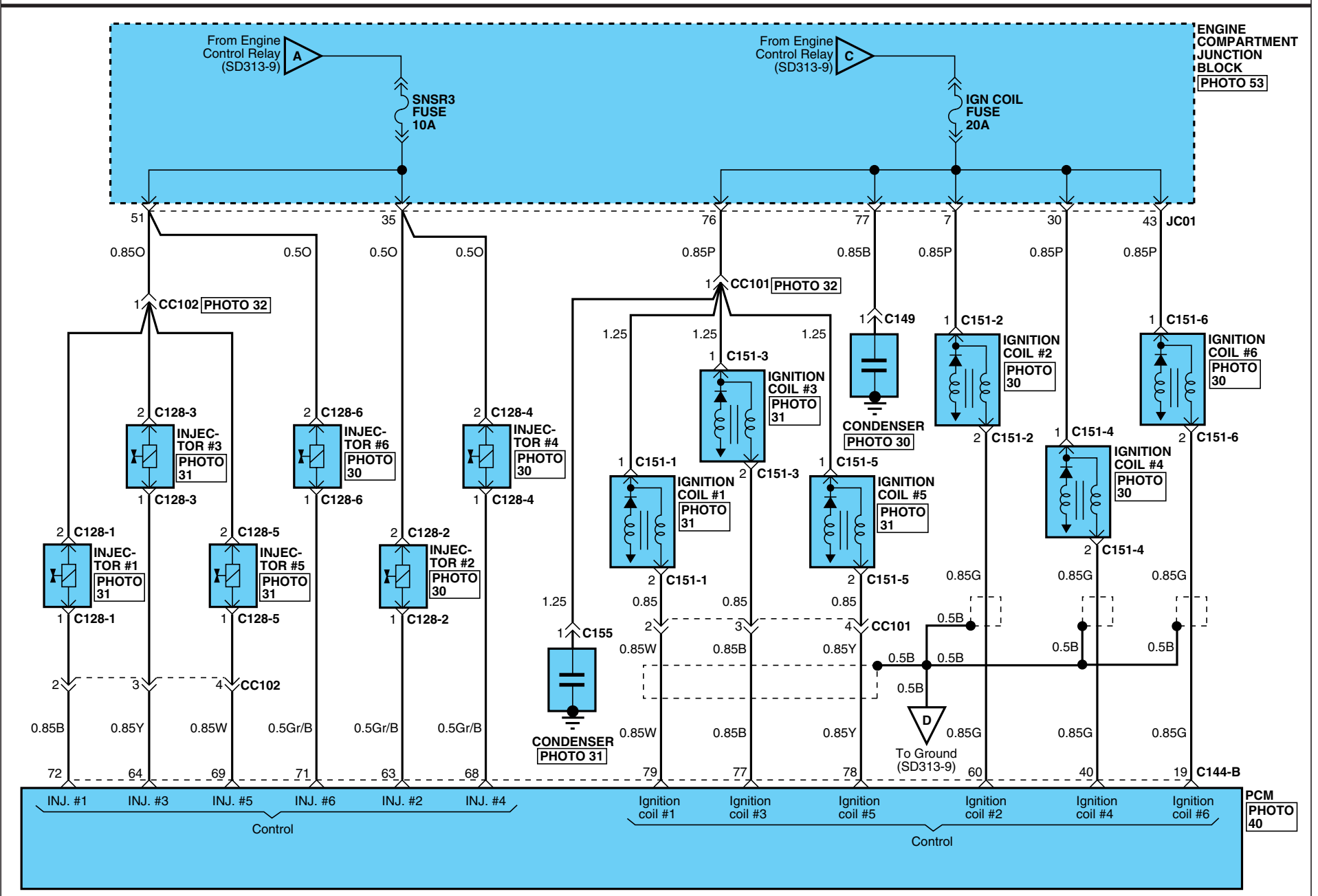

# MFI CONTROL SYSTEM

## MFI CONTROL SYSTEM (GSL 3.3L/3.8L) (4)

SD313-12

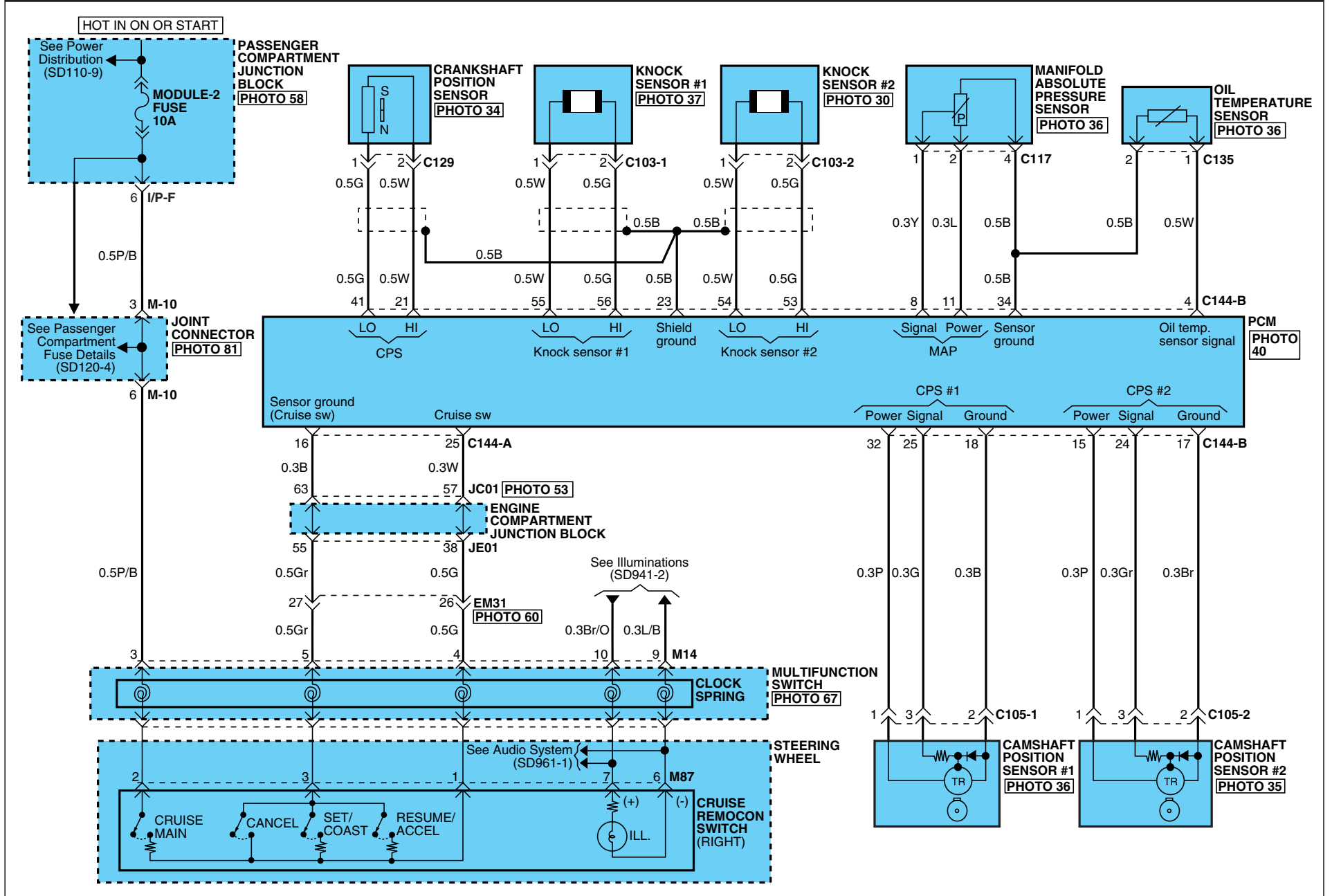

# MFI CONTROL SYSTEM

## MFI CONTROL SYSTEM (GSL 3.3L/3.8L) (5)

SD313-13

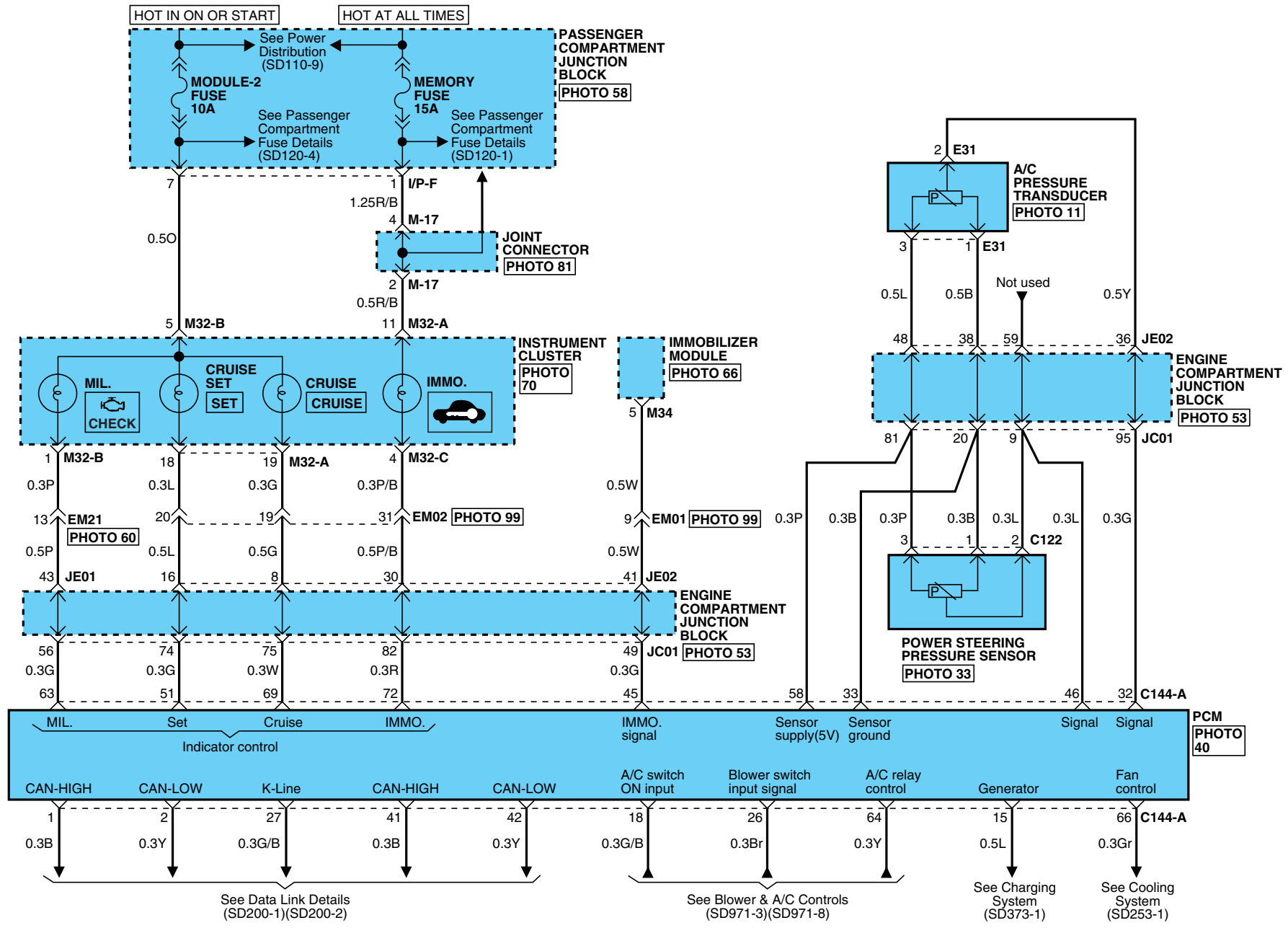

# MFI CONTROL SYSTEM

## MFI CONTROL SYSTEM (GSL 3.3L/3.8L) (6)

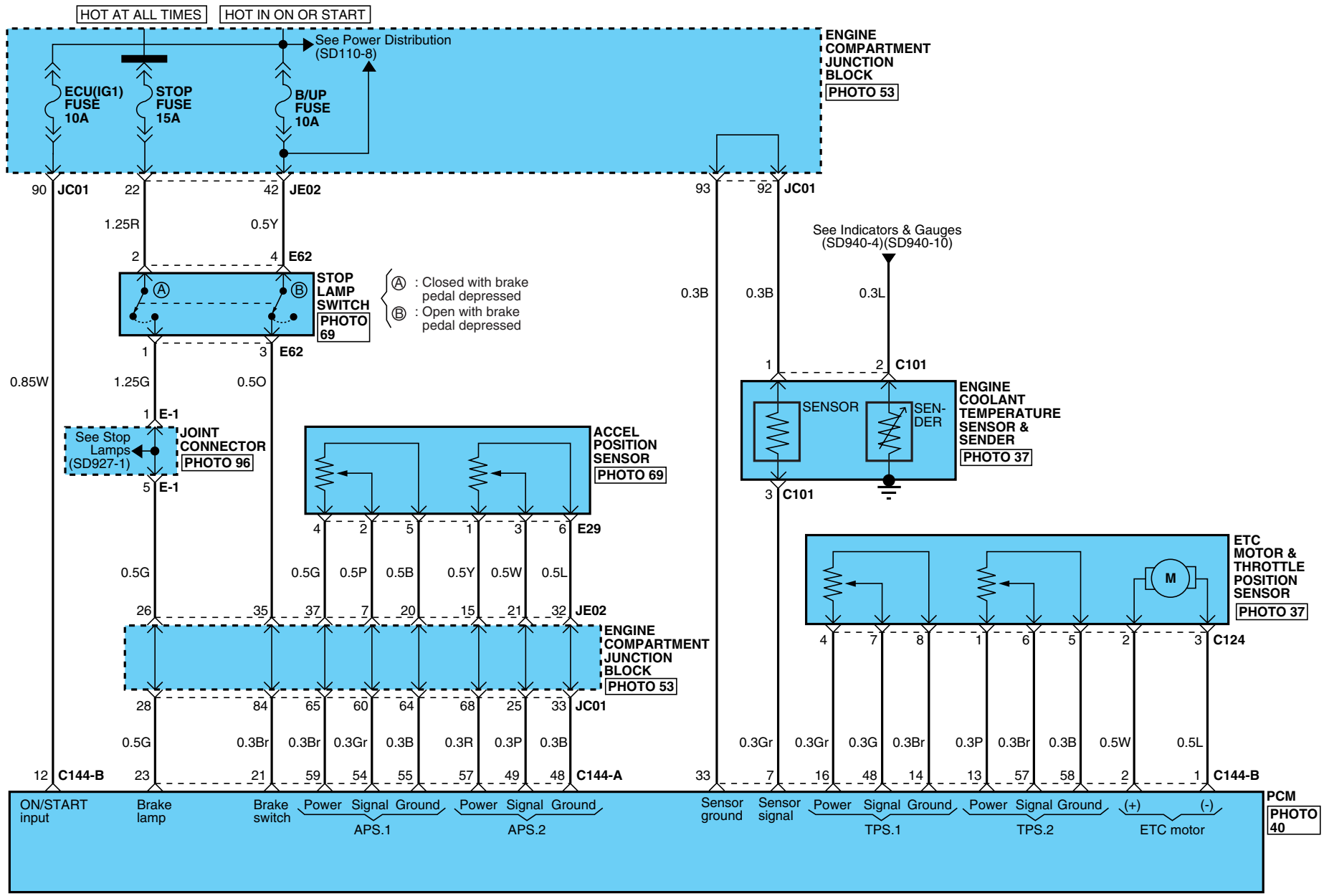

SD313-14



# MFI CONTROL SYSTEM

## MFI CONTROL SYSTEM (GSL 3.3L/3.8L) (7)

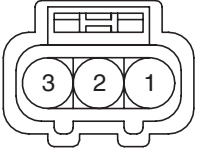
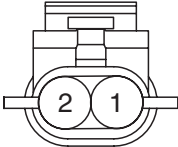
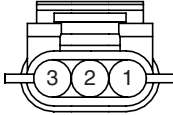
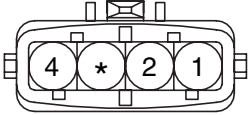
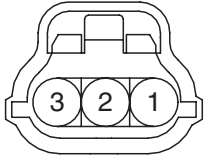
SD313-15

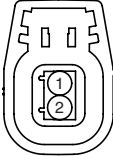
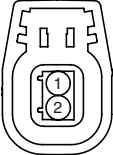
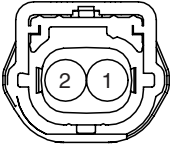
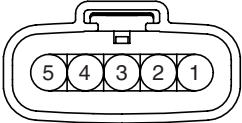
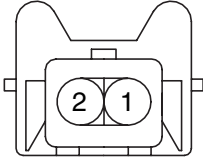
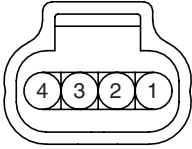
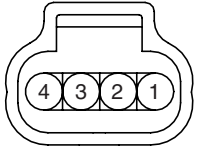
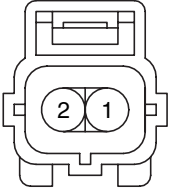
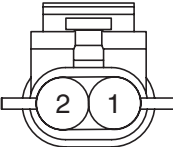
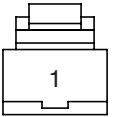
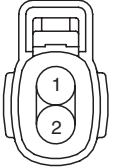
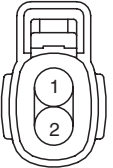
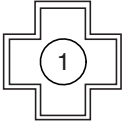
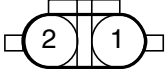
<p><b>C101</b></p>  <p>KUM_62Z_03F_B_WTS</p>	<p><b>C103-1,2</b></p>  <p>PKD_MP150_02F_GR</p>	<p><b>C105-1,2</b></p>  <p>PKD_150WP_03F_B_L</p>	<p><b>C117</b></p>  <p>JPT_04F_B_BOSCH</p>
<p><b>C122</b></p>  <p>YAZ_040WP_03F_B</p>	<p><b>C124</b></p>  <p>PKD_GT150_08F_B</p>	<p><b>C128-1,3,5</b></p>  <p>PKD_GT150_02F_B</p>	<p><b>C128-2,4,6</b></p>  <p>PKD_GT150_02F_B</p>
<p><b>C129</b></p>  <p>BSH_SENSOR_02F_B</p>	<p><b>C130</b></p>  <p>PKD_GT150_05F_B</p>	<p><b>C135</b></p>  <p>AMP_JPT_02F_B_CLIP</p>	<p><b>C137/C140</b></p>  <p>PKD_GT150_04F_Gr</p>
<p><b>C138/C139</b></p>  <p>PKD_GT150_04F_B</p>	<p><b>C146</b></p>  <p>AMP_EJWP_02F_B</p>	<p><b>C148</b></p>  <p>PKD_MP150_02F_B</p>	<p><b>C149</b></p>  <p>KET_250_01F_B_1</p>
<p><b>C151-1,3,5</b></p>  <p>KET_090IWP_02F_Gr_VER</p>	<p><b>C151-2,4,6</b></p>  <p>KET_090IWP_02F_Gr_VER</p>	<p><b>C155</b></p>  <p>CR01F054</p>	<p><b>C156-1,2</b></p>  <p>CR02F134</p>



MFI CONTROL SYSTEM

MFI CONTROL SYSTEM (GSL 3.3L/3.8L) (8)

SD313-16

C144-A

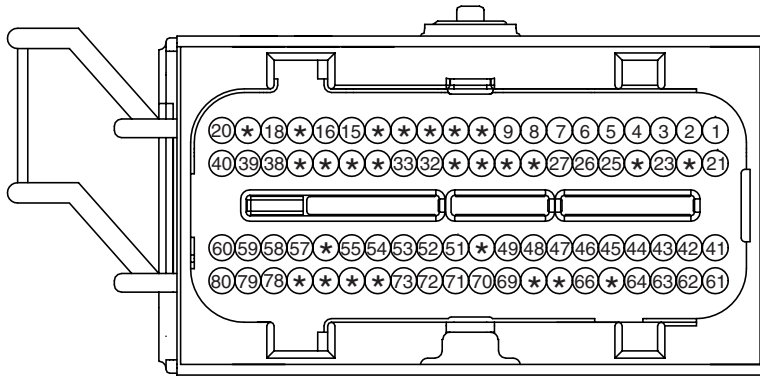

PKD\_ECU\_80F\_B\_1

C144-B

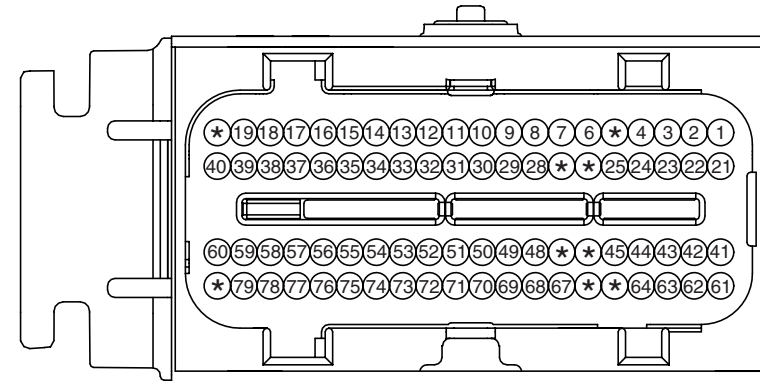

PKD\_ECU\_80F\_B\_2

E29

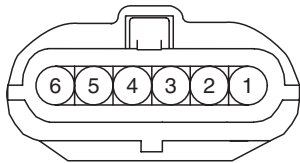

AMP\_070WP\_06F\_B

E31

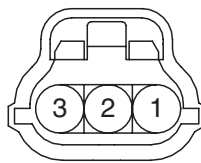

YAZ\_040WP\_03F\_B

E57

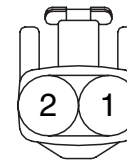

KET\_090IWP\_02F\_B

E62

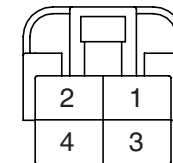

KET\_250DL\_04F\_W

F21

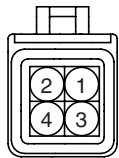

AMP\_MCP\_E\_04F\_B

BLANK

M14

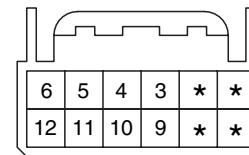

AMP\_025\_12F\_W

M32-A

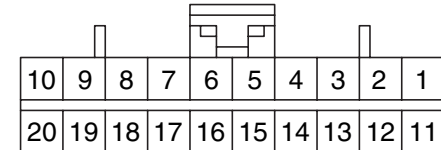

AMP\_040M2\_20F\_B

M32-B

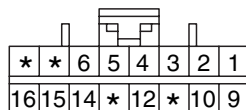

AMP\_040M2\_16F\_B

M32-C

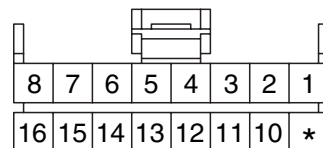

AMP\_040M1\_16F\_B

M87

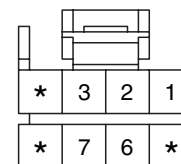

AMP\_040M1\_08F\_B

BLANK

MFI CONTROL SYSTEM (DIESEL) (1)

SD313-17

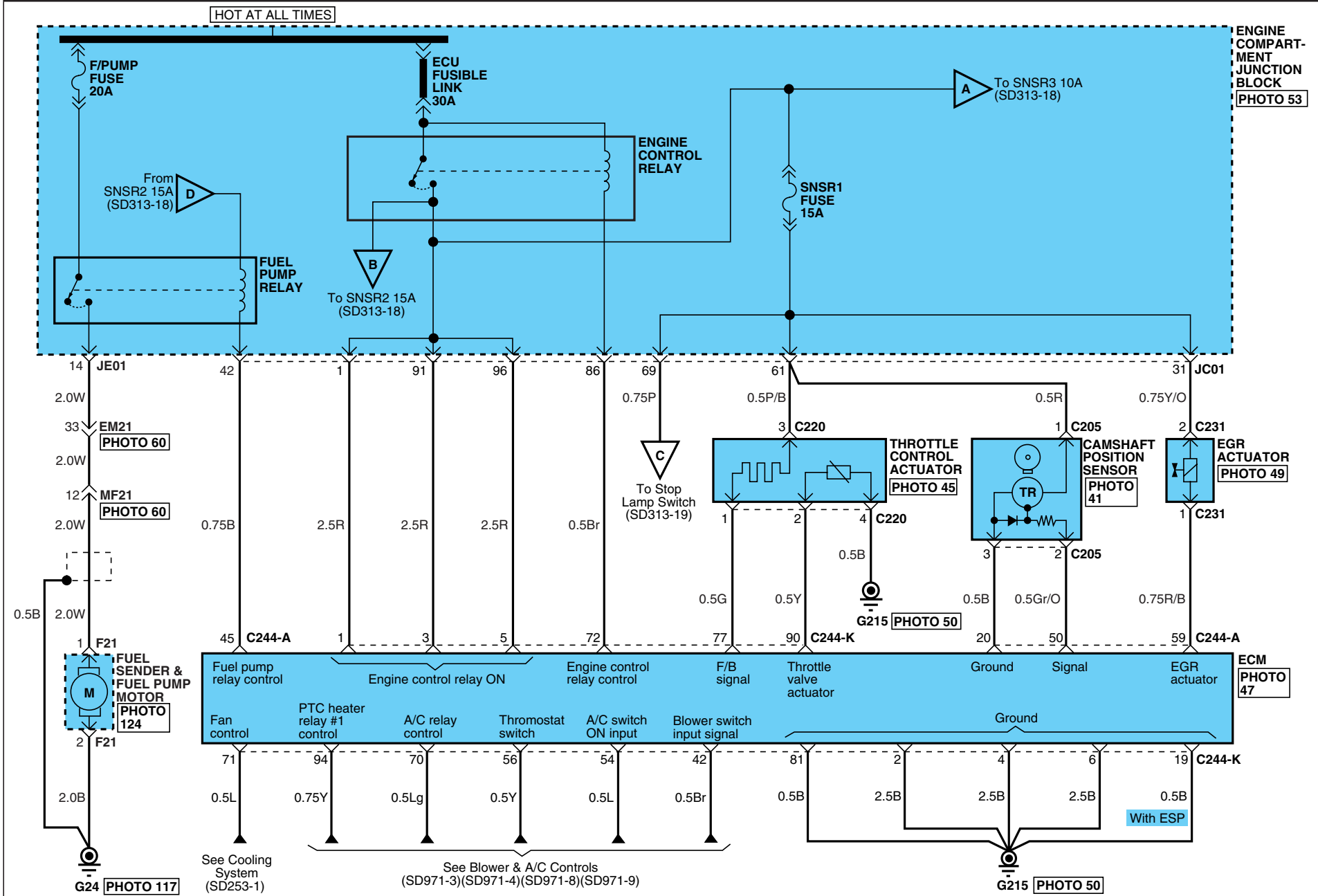

# MFI CONTROL SYSTEM

## MFI CONTROL SYSTEM (DIESEL) (2)

SD313-18

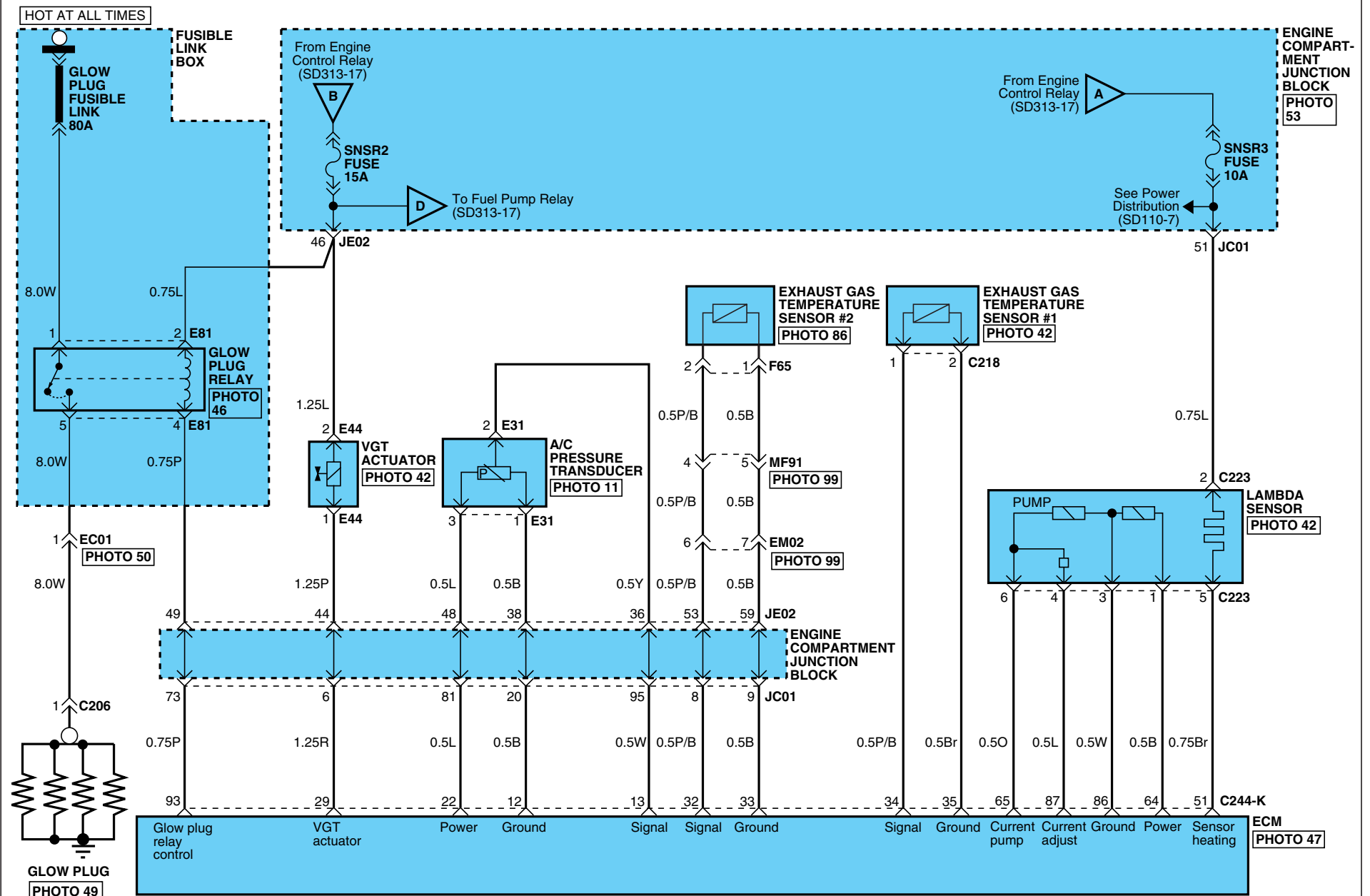

MFI CONTROL SYSTEM

MFI CONTROL SYSTEM (DIESEL) (3)

SD313-19

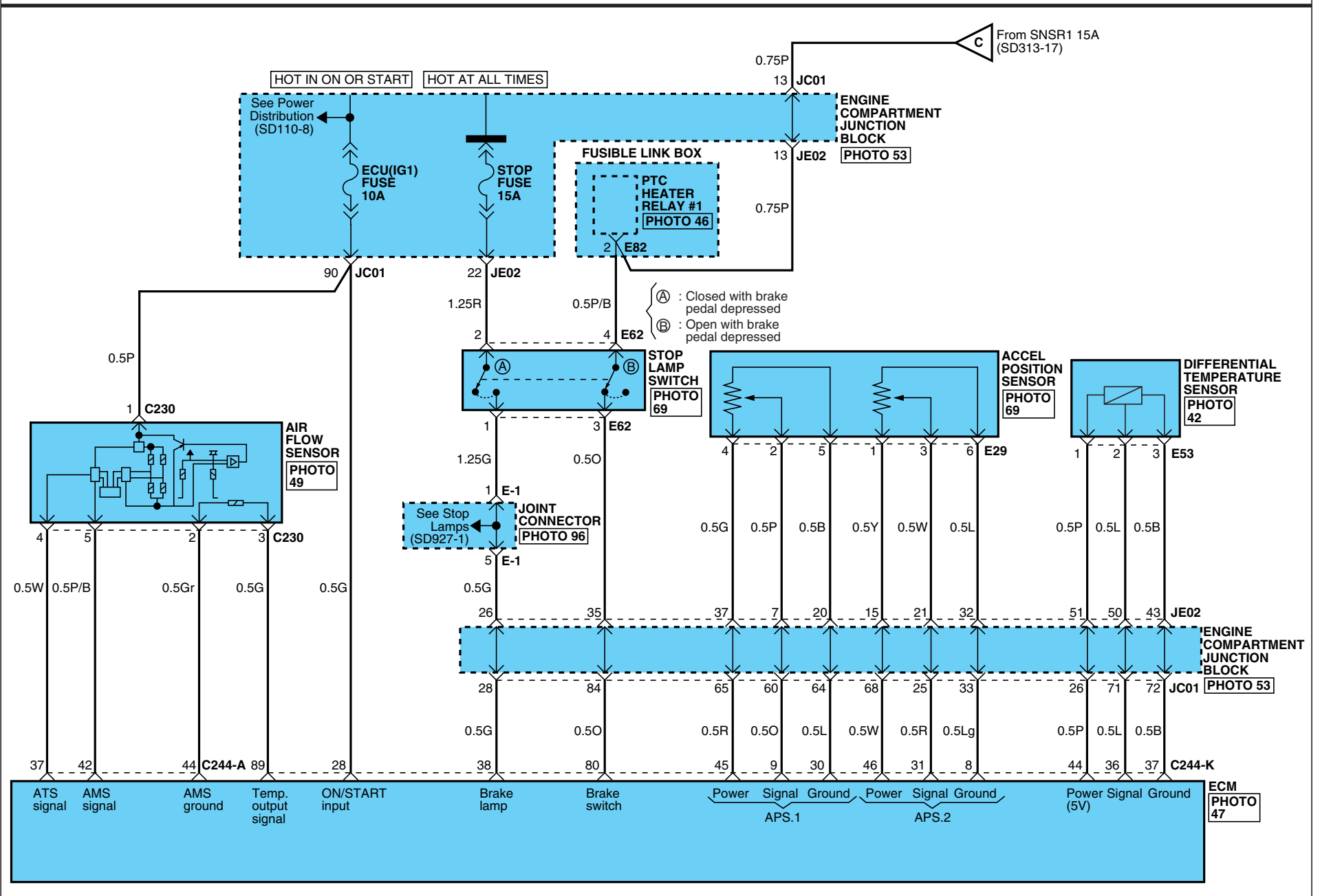

# MFI CONTROL SYSTEM

## MFI CONTROL SYSTEM (DIESEL) (4)

SD313-20

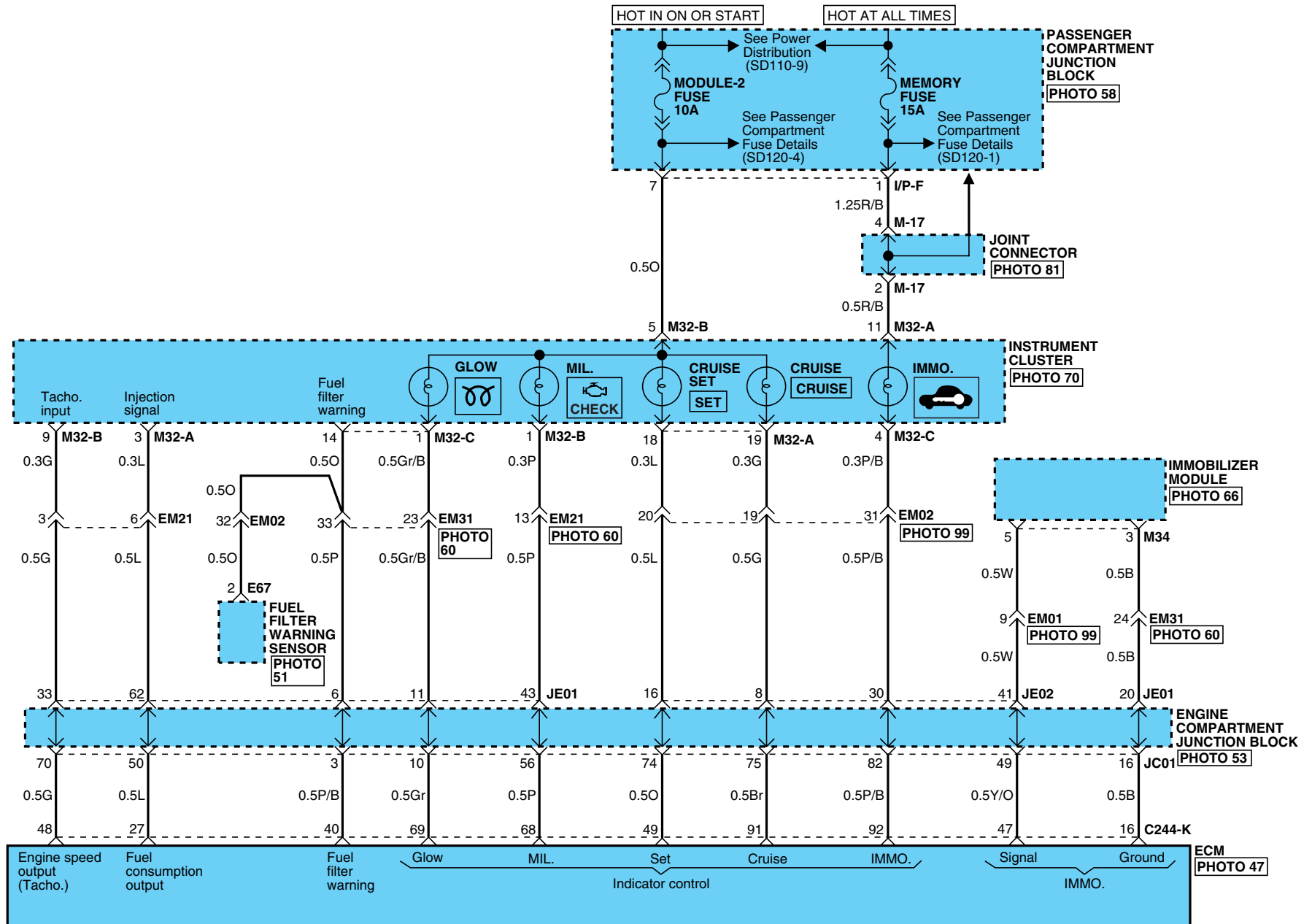

# MFI CONTROL SYSTEM

## MFI CONTROL SYSTEM (DIESEL) (5)

SD313-21

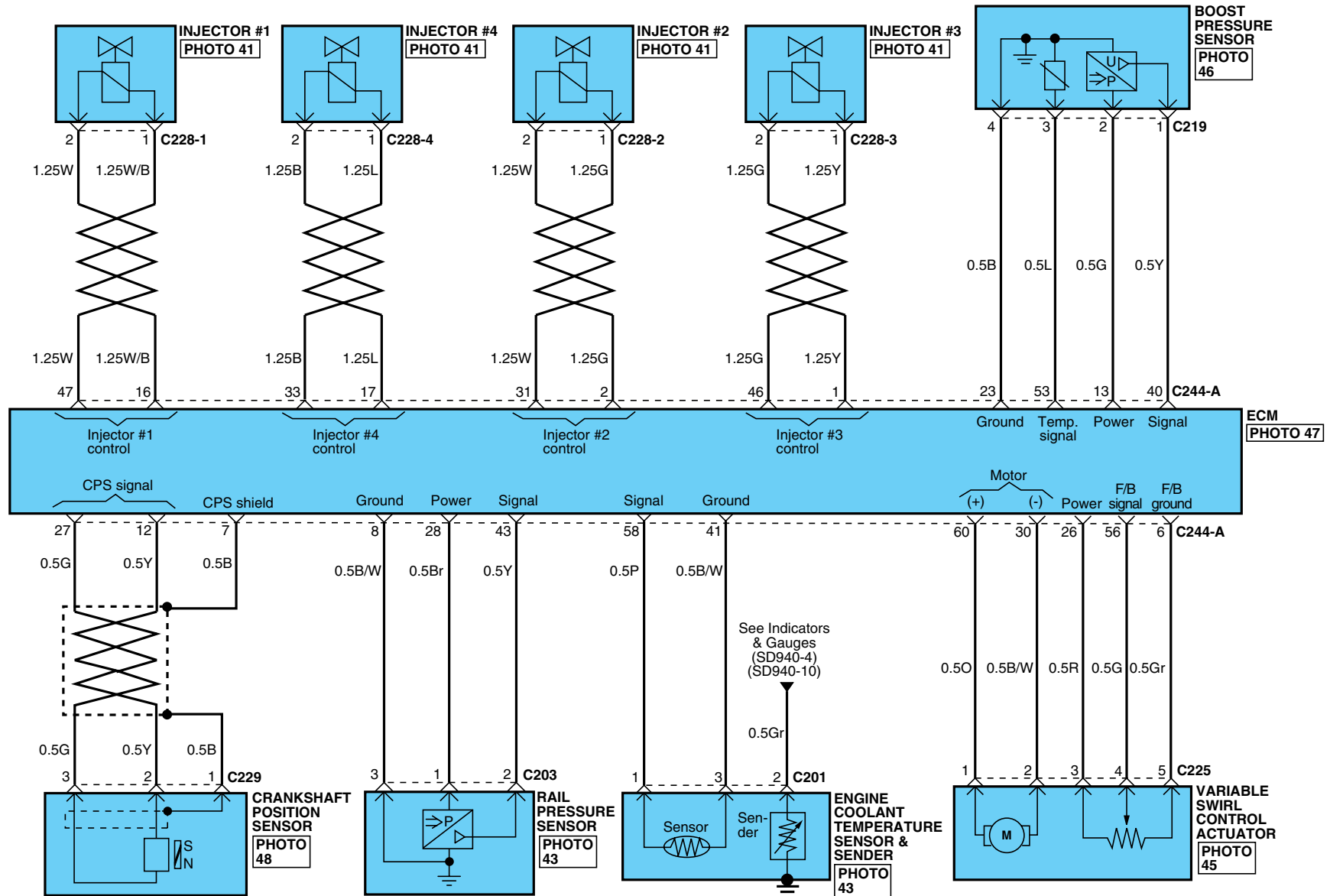

# MFI CONTROL SYSTEM

## MFI CONTROL SYSTEM (DIESEL) (6)



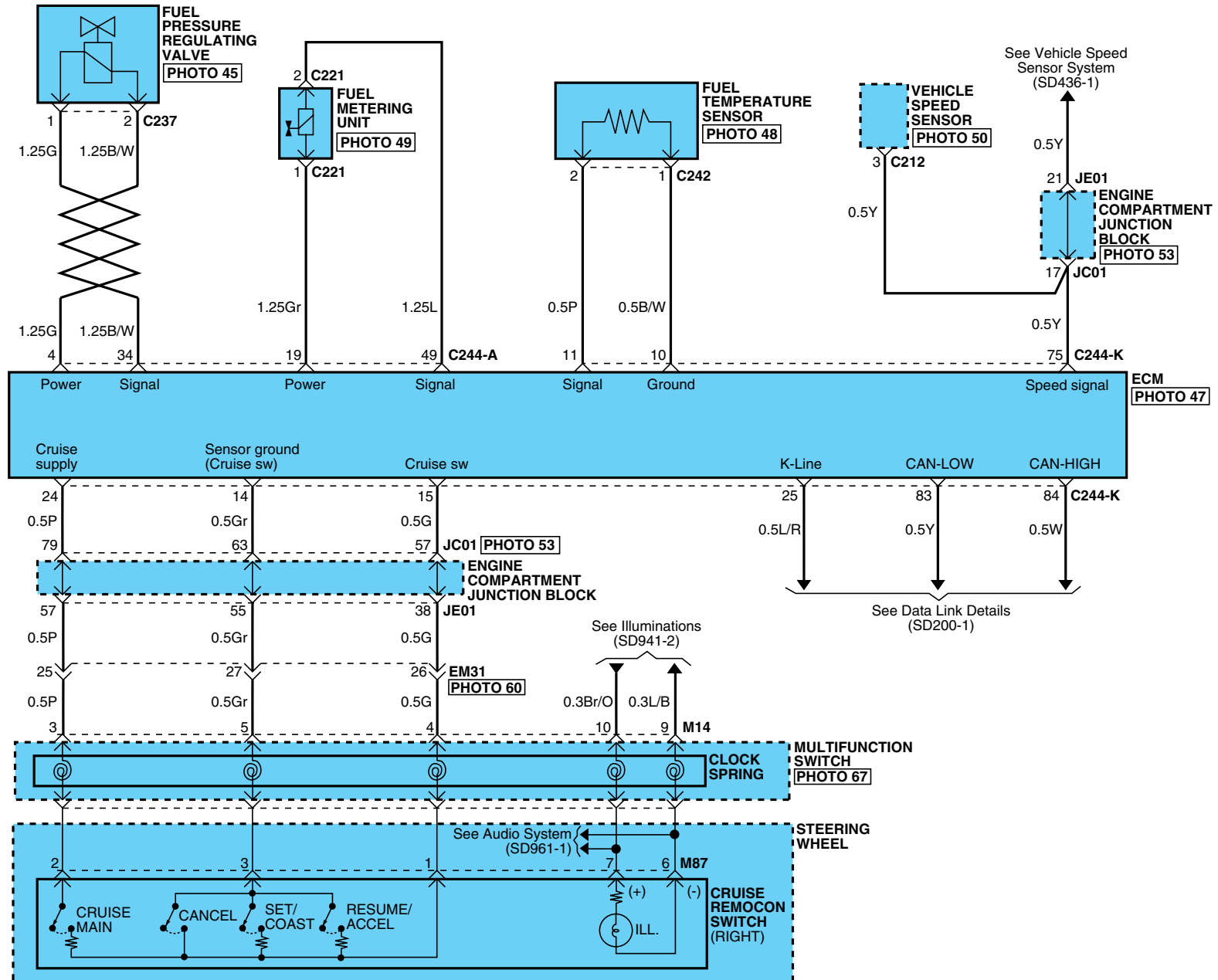





SD313-22

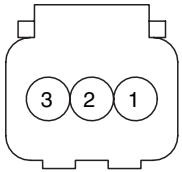
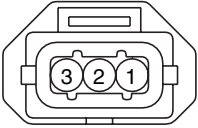
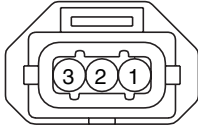
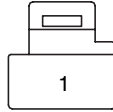

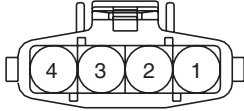
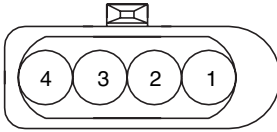
**MFI CONTROL SYSTEM**

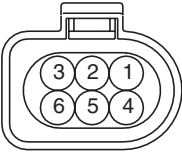
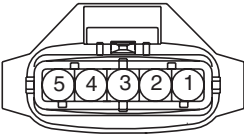
**MFI CONTROL SYSTEM (DIESEL) (7)**

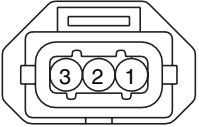
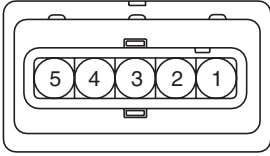
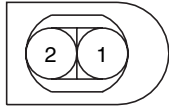
**SD313-23**

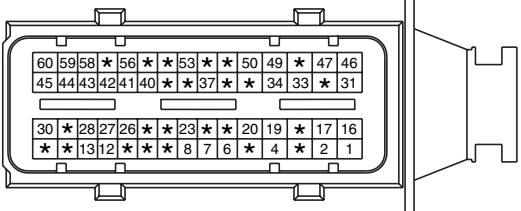
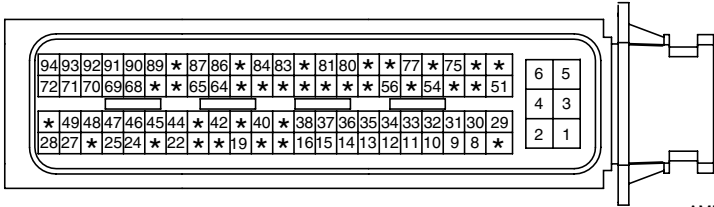
<p><b>C201</b></p>  <p>KUM_WTS_03F_B</p>	<p><b>C203</b></p>  <p>AMP_SFT_03F_B_2</p>	<p><b>C205</b></p>  <p>AMP_SFT_03F_B_1</p>	<p><b>C206</b></p>  <p>KET_58L_01F_B</p>
<p><b>C218</b></p>  <p>AMP_JPT_02F_BSH2_B</p>	<p><b>C219</b></p>  <p>AMP_JPT_04F_B_BOSCH</p>	<p><b>C220</b></p>  <p>FBP_NFDSL_04F_N</p>	<p><b>C221</b></p>  <p>AMP_JPT_02F_BSH2_B</p>
<p><b>C223</b></p>  <p>BSH_SENSOR_06F_B_NF</p>	<p><b>C225</b></p>  <p>AMP_JPT_05F_B_SFS</p>	<p><b>C228-1,3</b></p>  <p>AMP_JPT_02F_BSH2_B</p>	<p><b>C228-2,4</b></p>  <p>AMP_JPT_02F_BSH2_B</p>
<p><b>C229</b></p>  <p>AMP_SFT_03F_B_1</p>	<p><b>C230</b></p>  <p>HIRSCHMANN</p>	<p><b>C231</b></p>  <p>KST_SENSOR_02F_B_NF</p>	<p><b>C237</b></p>  <p>AMP_JPT_02F_BSH2_B</p>
<p><b>C244-A</b></p>  <p>AMP_ECU_60F_B</p>		<p><b>C244-K</b></p>  <p>AMP_ECU_94F_B</p>	



# MFI CONTROL SYSTEM

## MFI CONTROL SYSTEM (DIESEL) (8)

SD313-24

**C242**

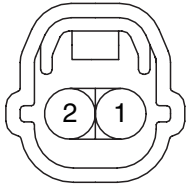

KET\_SSD\_02F\_B

**E29**

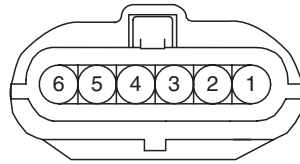

AMP\_070WP\_06F\_B

**E31**

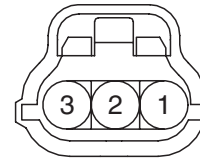

YAZ\_040WP\_03F\_B

**E44**

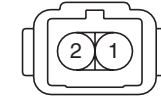

KET\_ITC\_02F\_B

**E53**



SUM\_090IWP\_03F

**E62**

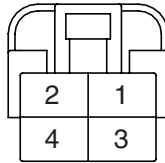

KET\_250DL\_04F\_W

**E67**

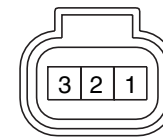

AMP\_090\_03F\_B\_WP

**E81**

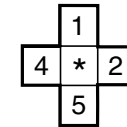

CR05F019

**F21**

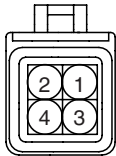

AMP\_MCP\_E\_04F\_B

**F65**

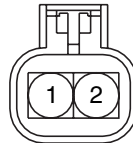

SUM\_SENSOR\_02M\_W

**M14**

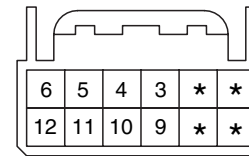

AMP\_025\_12F\_W

**M32-A**

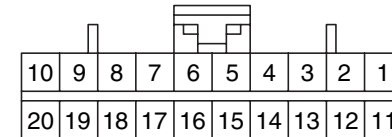

AMP\_040M2\_20F\_B

**M32-B**

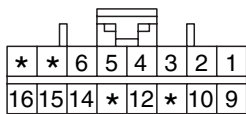

AMP\_040M2\_16F\_B

**M32-C**

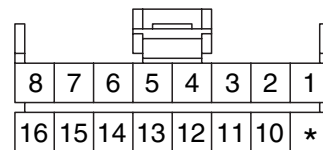

AMP\_040M1\_16F\_B

**M34**

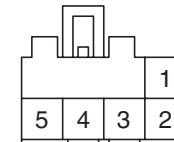

KUM\_CDR\_05F\_W

**M87**

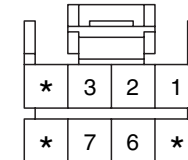

AMP\_040M1\_08F\_B

STARTING SYSTEM (1)

SD360-1

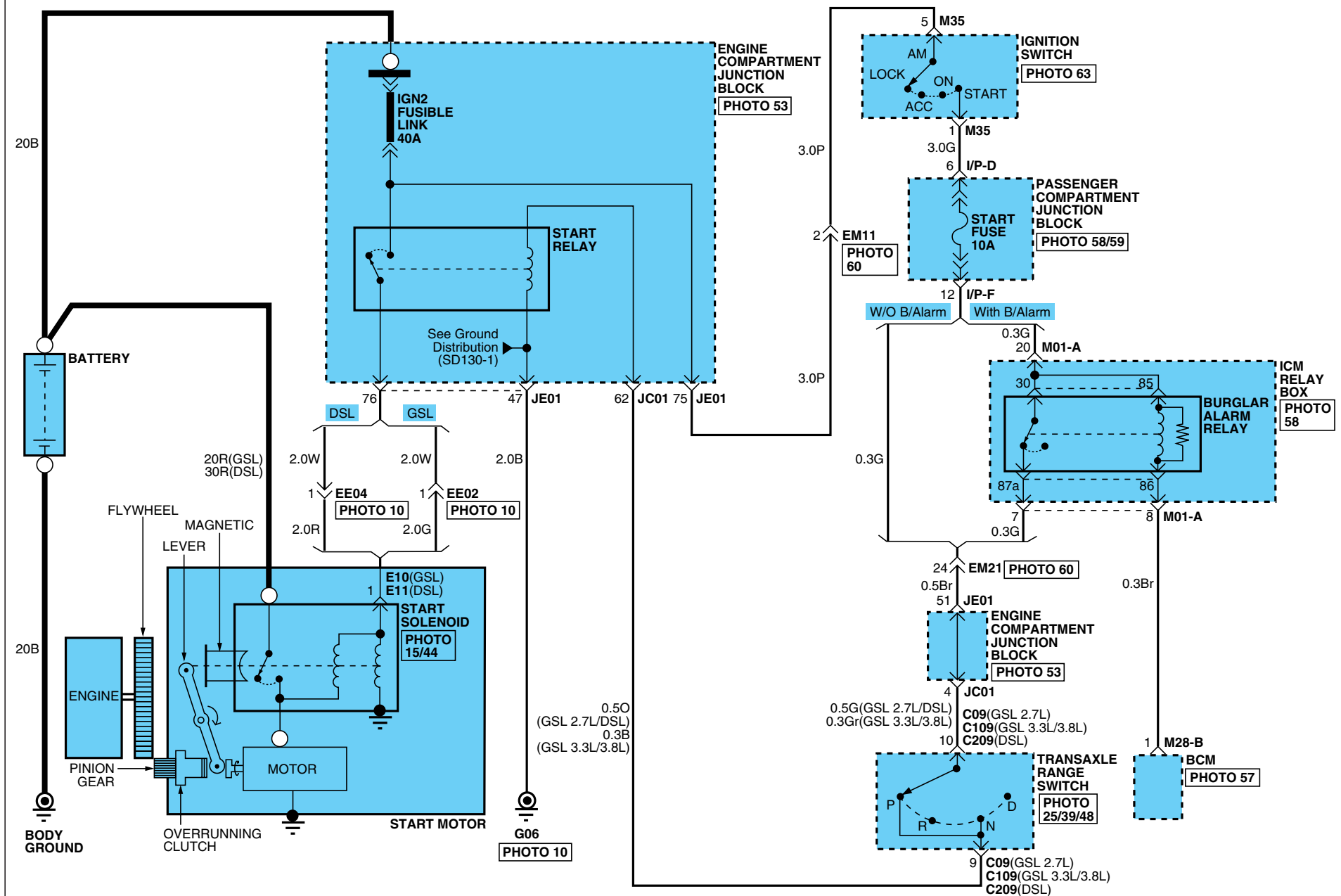

# STARTING SYSTEM

## STARTING SYSTEM (2)

SD360-2

**C09/C109/C209**



KET\_SSD\_10F\_B\_A

**E10**

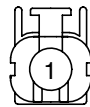

KET\_250WP\_1F\_B

**E11**

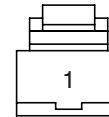

KET\_250\_01F\_B

**M01-A**

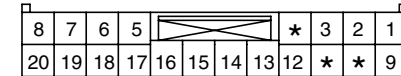

AMP\_0925\_20F\_W

**M28-B**

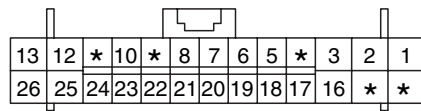

AMP\_0407\_26F\_W\_HD

**M35**

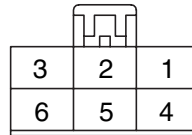

KUM\_DSD\_06F\_W

**BLANK**

**BLANK**

FUEL FILTER HEATING SYSTEM (DIESEL) (1)

SD361-1

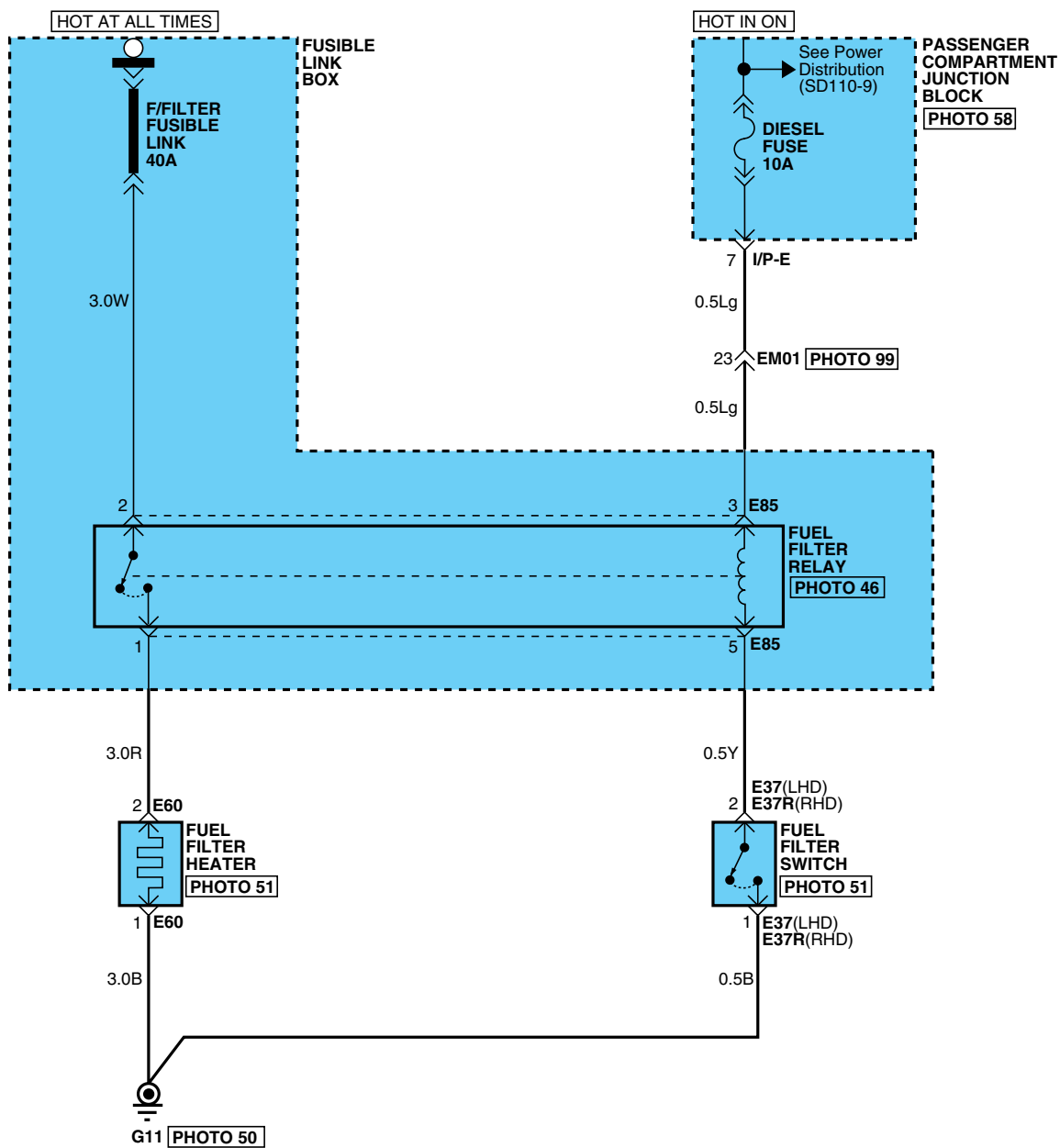

# FUEL FILTER HEATING SYSTEM

## FUEL FILTER HEATING SYSTEM (DIESEL) (2)

SD361-2

E37

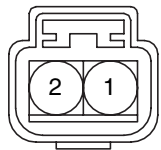

KUM\_NMWP\_02F\_B

E37R

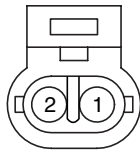

AMP\_060WP\_02F\_B

E60

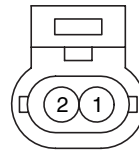

PKD\_280WP\_02F\_B\_1

E85

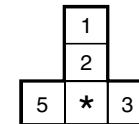

CR05F011

CHARGING SYSTEM (1)

SD373-1

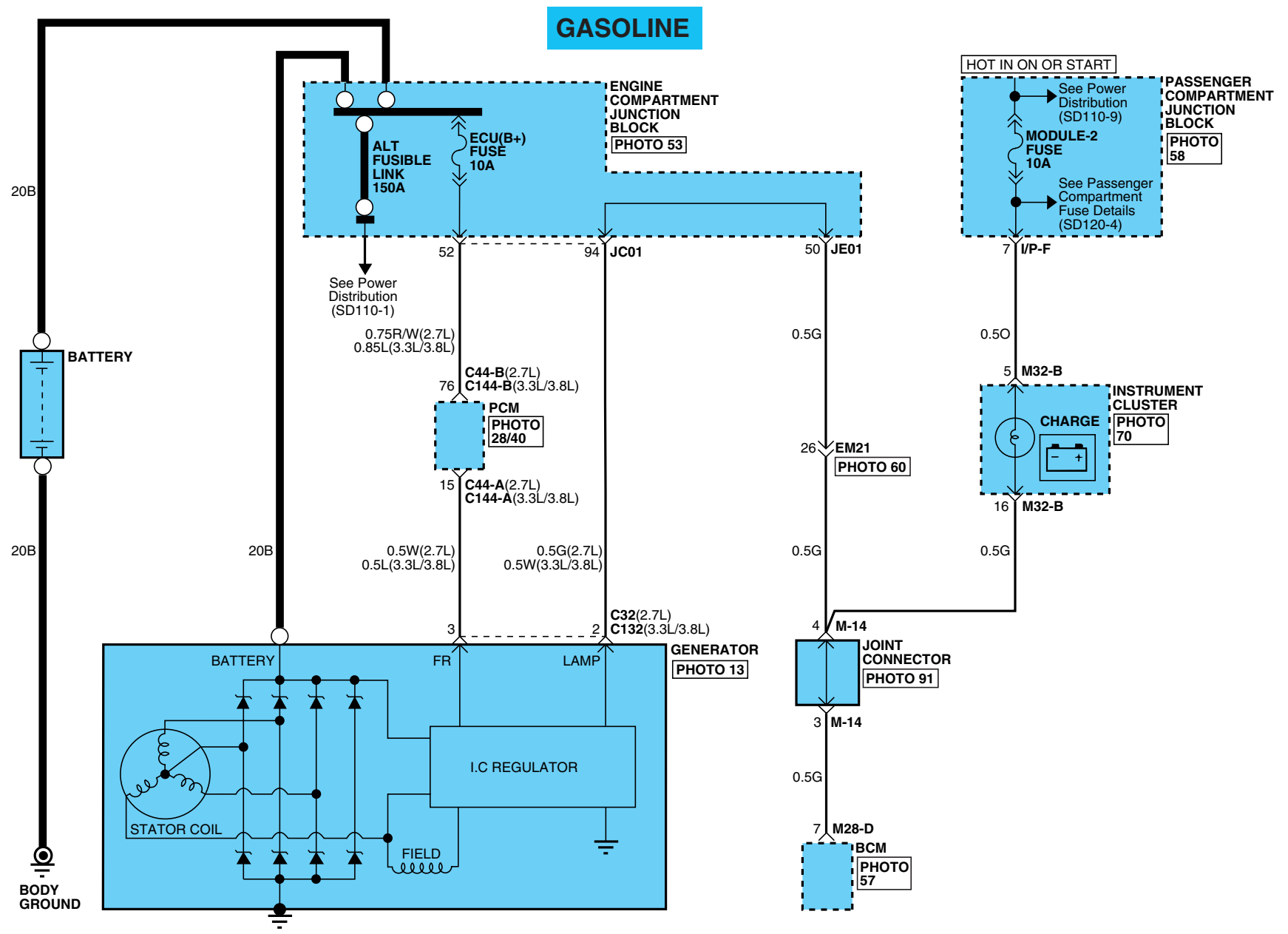

CHARGING SYSTEM

CHARGING SYSTEM (2)

SD373-2

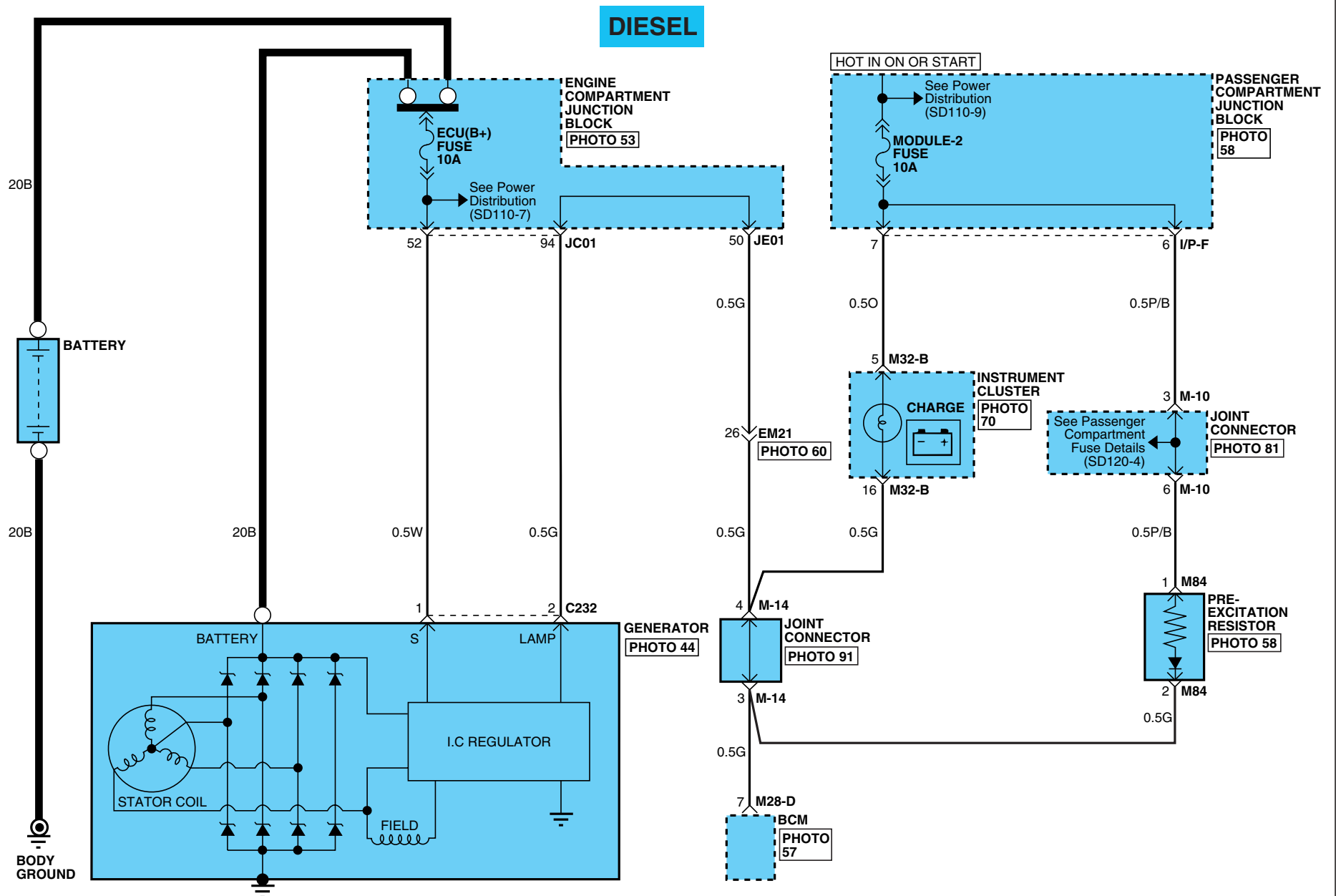

# CHARGING SYSTEM

## CHARGING SYSTEM (3)

SD373-3

**C44-A**

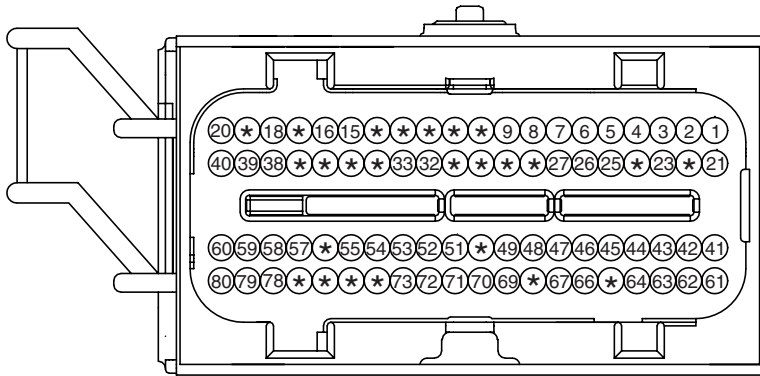

PKD\_ECU\_80F\_Gr\_1

**C44-B**

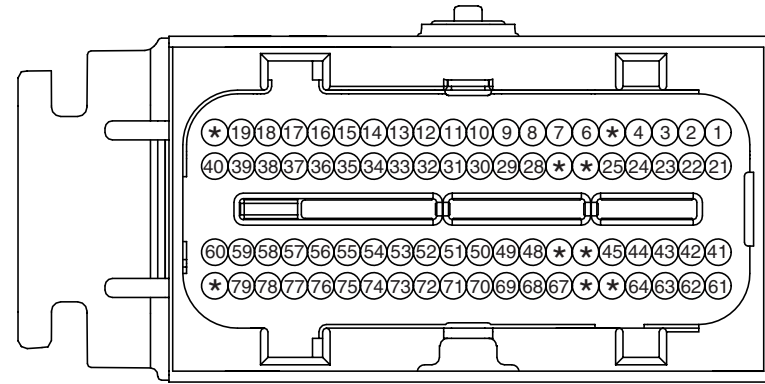

PKD\_ECU\_80F\_B\_2

**C144-A**

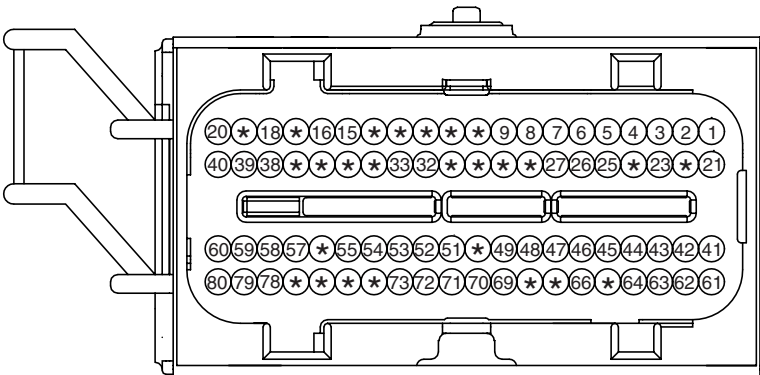

PKD\_ECU\_80F\_B\_1

**C144-B**

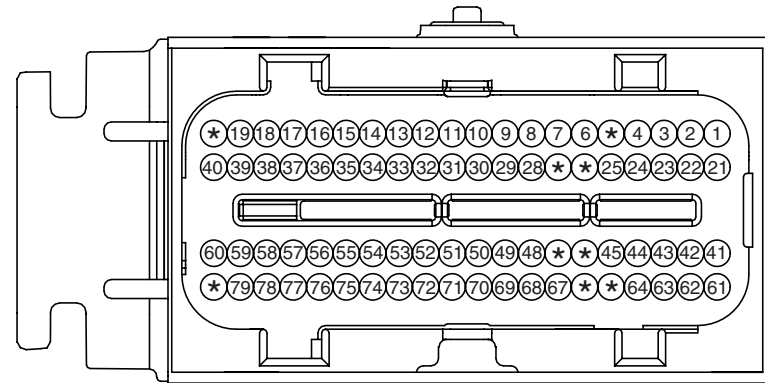

PKD\_ECU\_80F\_B\_2

**C32**

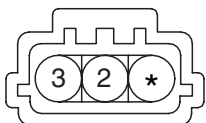

SUM\_ALTWP\_03F\_B

**C132**

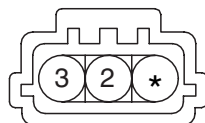

SUM\_ALTWP\_03F\_GR

**C232**

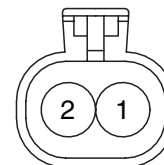

KET\_58X\_02F\_B

**M28-D**

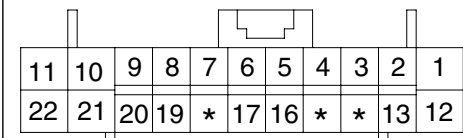

AMP\_0407\_22F\_W\_HD



# CHARGING SYSTEM

## CHARGING SYSTEM (4)

SD373-4

M32-B

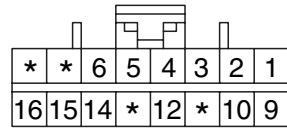

AMP\_040M2\_16F\_B

M84

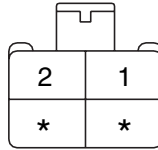

KET\_250\_04F\_W

BLANK

BLANK

# VEHICLE SPEED SENSOR SYSTEM

EEAD5DD0

## VEHICLE SPEED SENSOR SYSTEM (1)

SD436-1

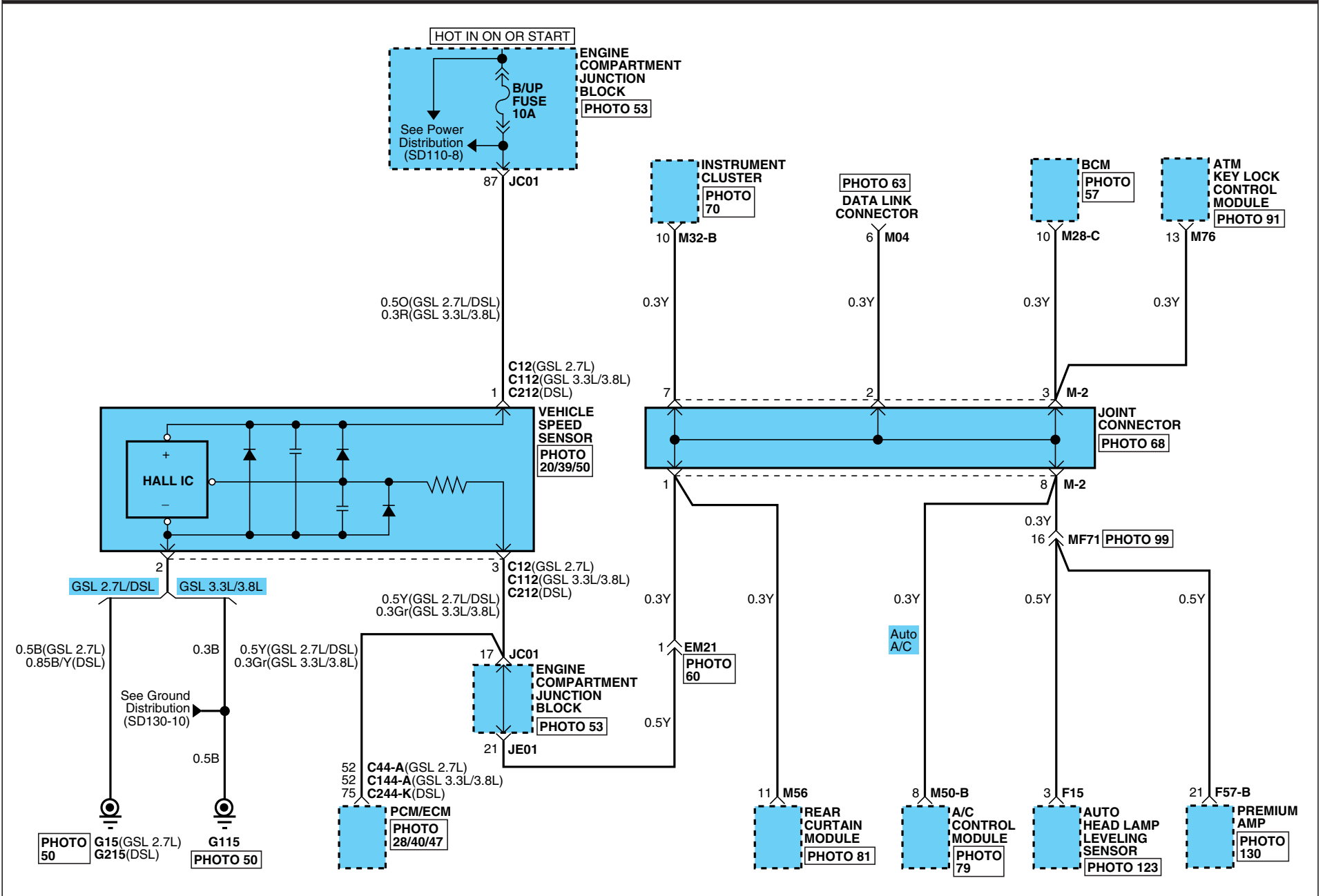

# VEHICLE SPEED SENSOR SYSTEM

## VEHICLE SPEED SENSOR SYSTEM (2)

SD436-2

C44-A

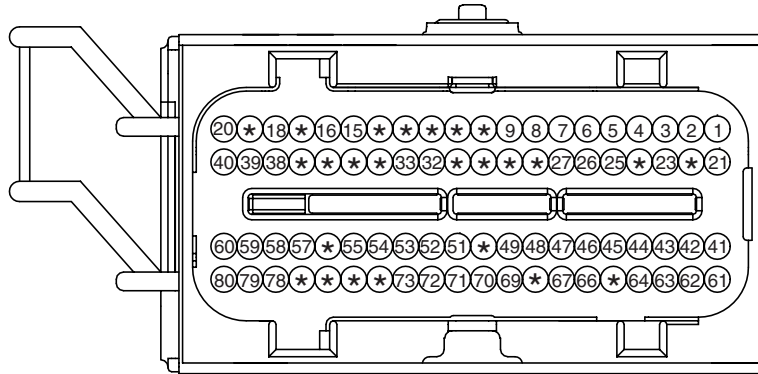

PKD\_ECU\_80F\_Gr\_1

C144-A

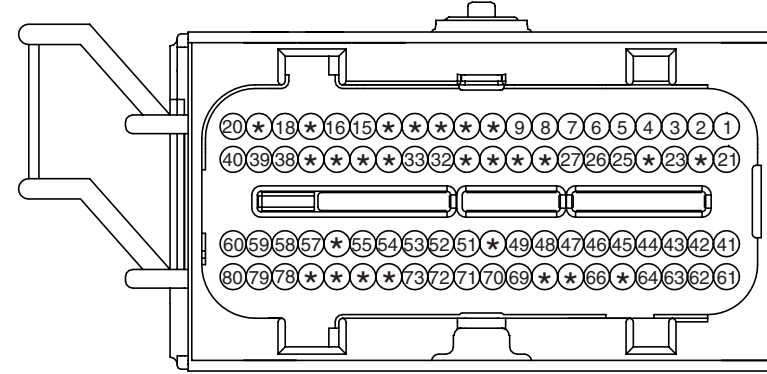

PKD\_ECU\_80F\_B\_1

C12/C112/C212

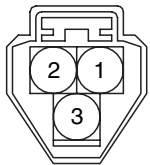

KUM\_NMWP\_03F\_B

C244-K

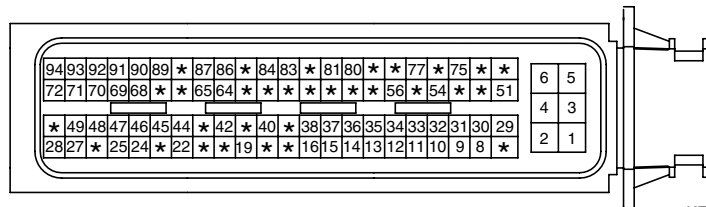

KET\_ECU\_94F\_B

F15

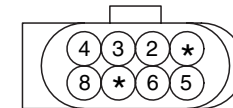

AMP\_DEV\_08F\_B

F57-B

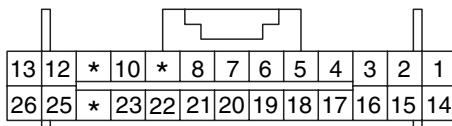

AMP\_0407\_MKII\_26F\_D\_GR

M04

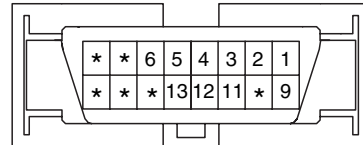

MLX\_OBDII\_16F\_B\_SIN

M28-C

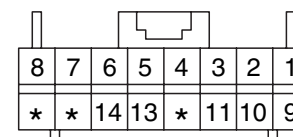

AMP\_0407\_16F\_W\_040

M32-B

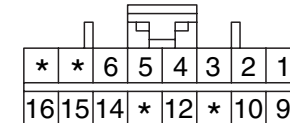

AMP\_040M2\_16F\_B

M50-B

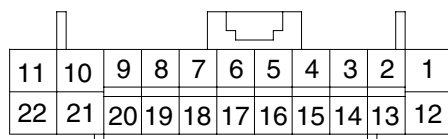

AMP\_0407\_22F\_W\_HD

M56

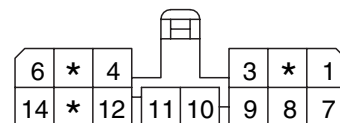

AMP\_070\_14F\_W

M76

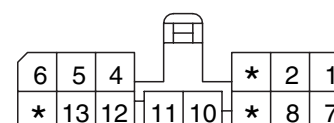

AMP\_070\_14F\_W

BLANK

**AUTOMATIC TRANSAXLE CONTROL SYSTEM (GSL 2.7L) (1)**

**SD450-1**

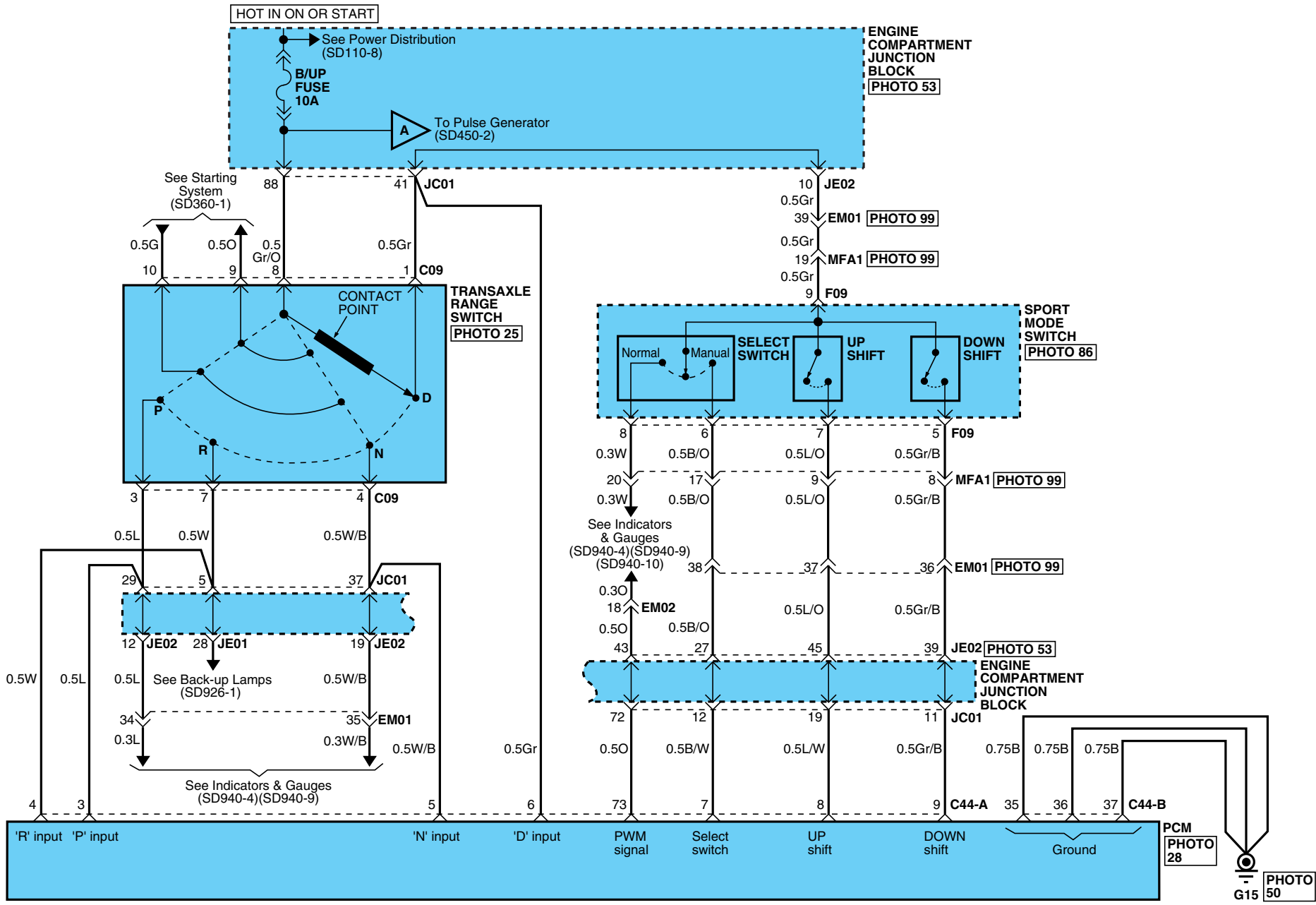

# AUTOMATIC TRANSAXLE CONTROL SYSTEM

## AUTOMATIC TRANSAXLE CONTROL SYSTEM (GSL 2.7L) (2)

SD450-2

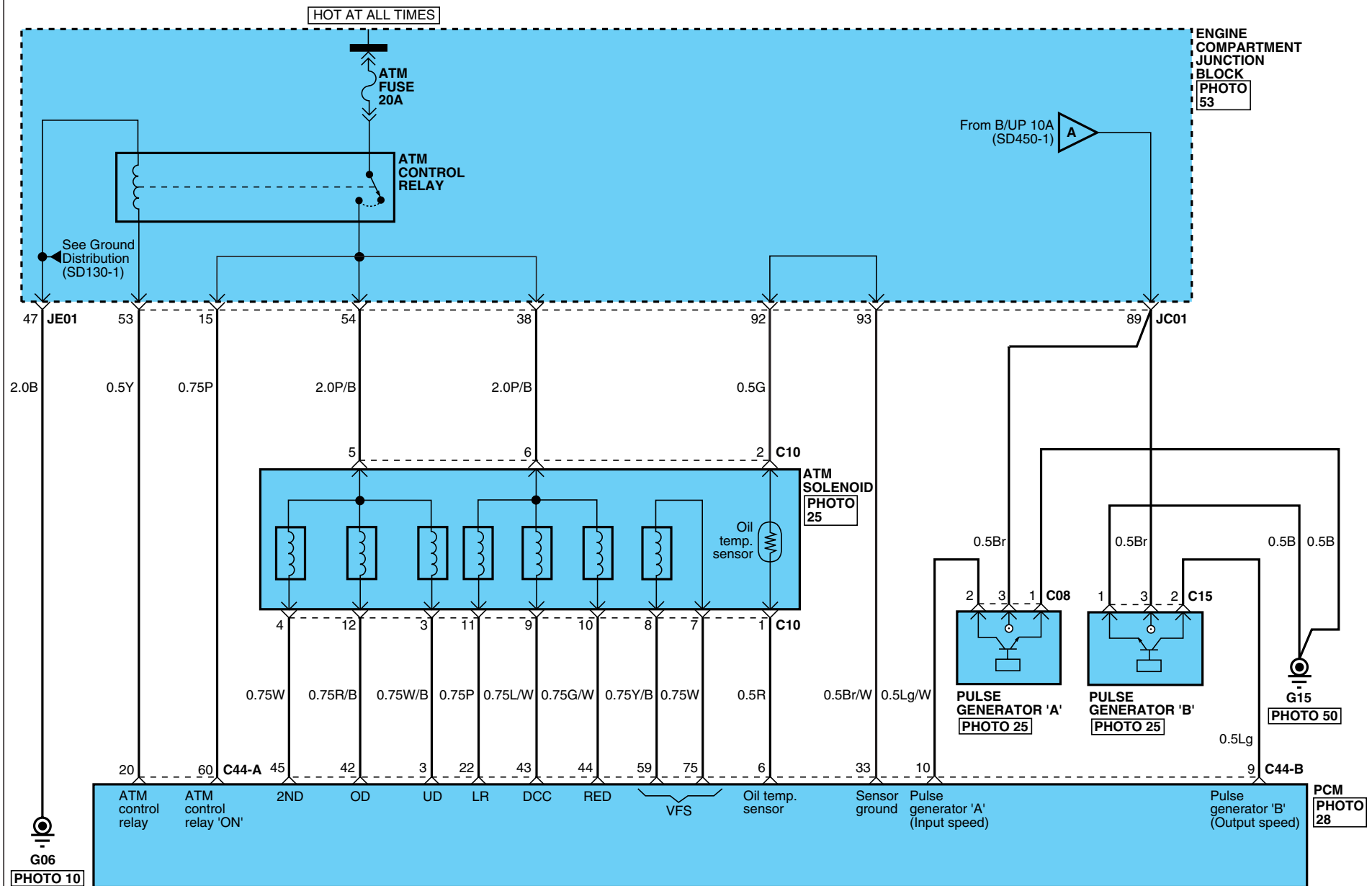

# AUTOMATIC TRANSAXLE CONTROL SYSTEM

## AUTOMATIC TRANSAXLE CONTROL SYSTEM (GSL 2.7L) (3)

SD450-3

**C08**

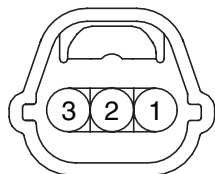

KET\_SSD\_03F\_B\_A

**C09**



KET\_SSD\_10F\_B\_A

**C10**



KET\_SSD\_12F\_B

**C15**

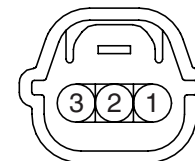

KET\_SSD\_03F\_Gr\_B

**C44-A**

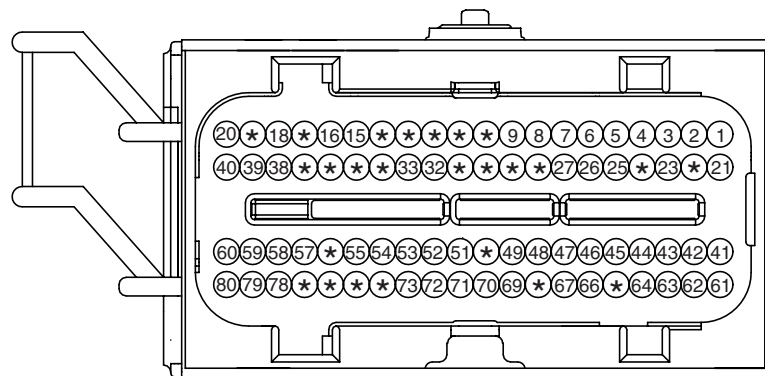

PKD\_ECU\_80F\_Gr\_1

**C44-B**

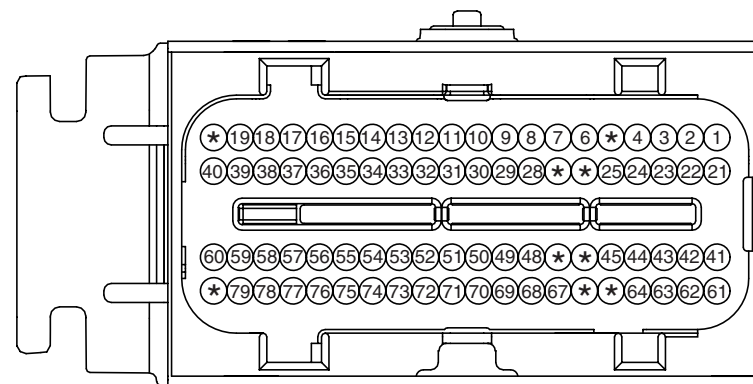

PKD\_ECU\_80F\_B\_2

**F09**

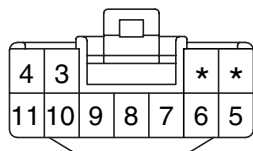

KET\_090II\_11F\_W

**BLANK**

**BLANK**

**BLANK**

**AUTOMATIC TRANSAXLE CONTROL SYSTEM**

**AUTOMATIC TRANSAXLE CONTROL SYSTEM (GSL 2.7L) (4)**

**SD450-4**

**MEMO**

AUTOMATIC TRANSAXLE CONTROL SYSTEM (GSL 3.3L/3.8L) (1)

SD450-5

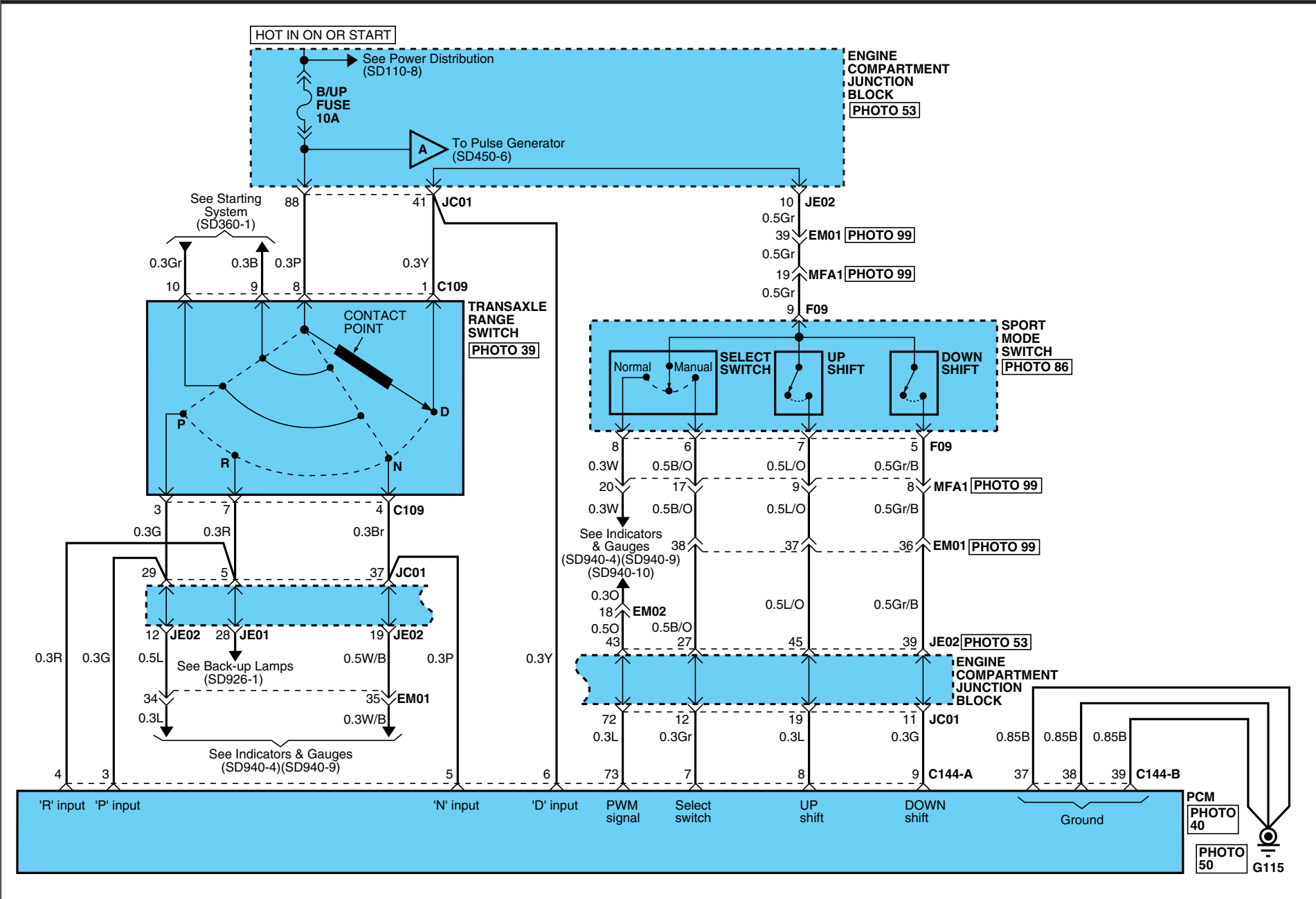



# AUTOMATIC TRANSAXLE CONTROL SYSTEM

## AUTOMATIC TRANSAXLE CONTROL SYSTEM (GSL 3.3L/3.8L) (2)

SD450-6

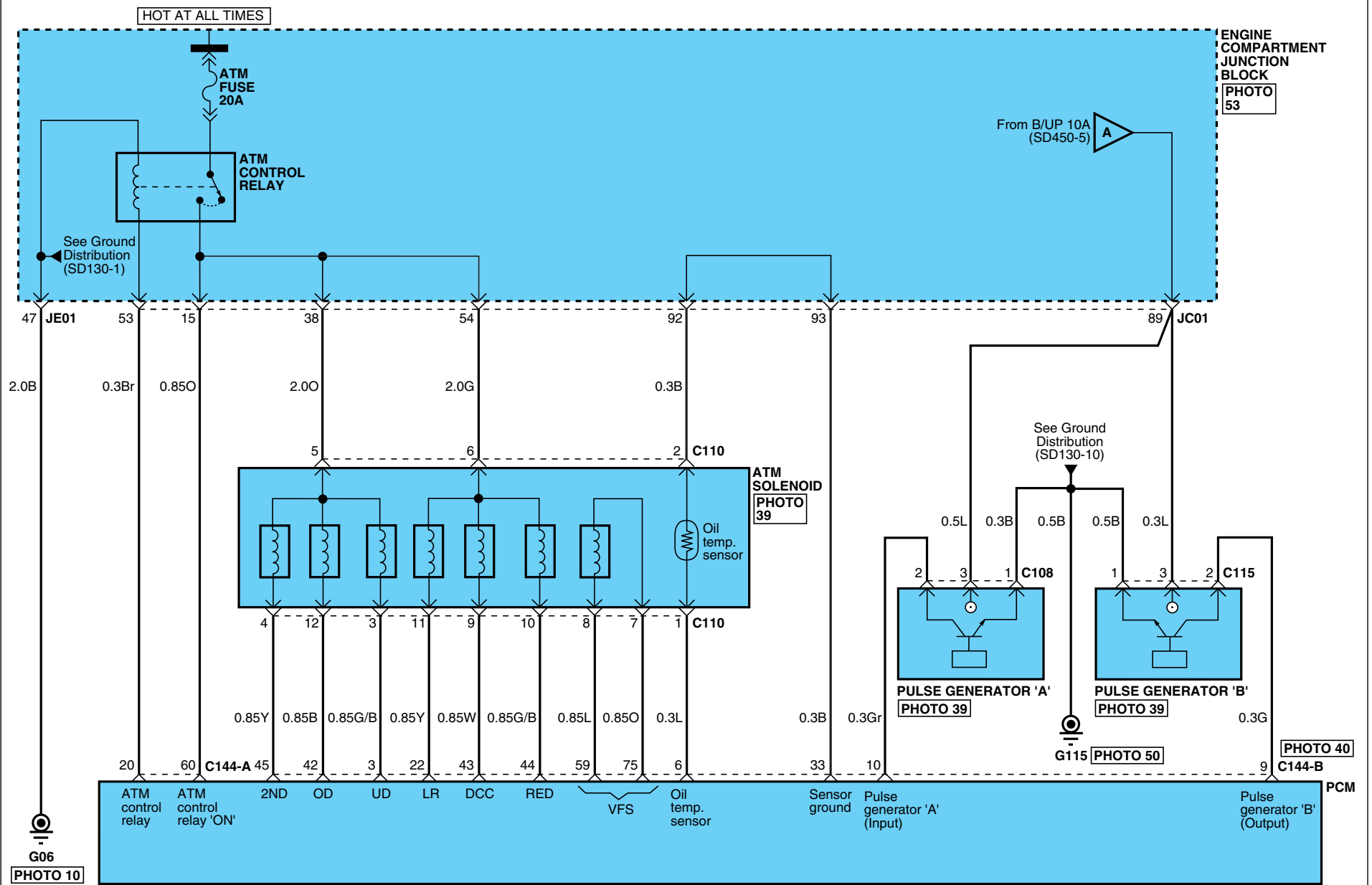

# AUTOMATIC TRANSAXLE CONTROL SYSTEM

## AUTOMATIC TRANSAXLE CONTROL SYSTEM (GSL 3.3L/3.8L) (3)

SD450-7

**C144-A**

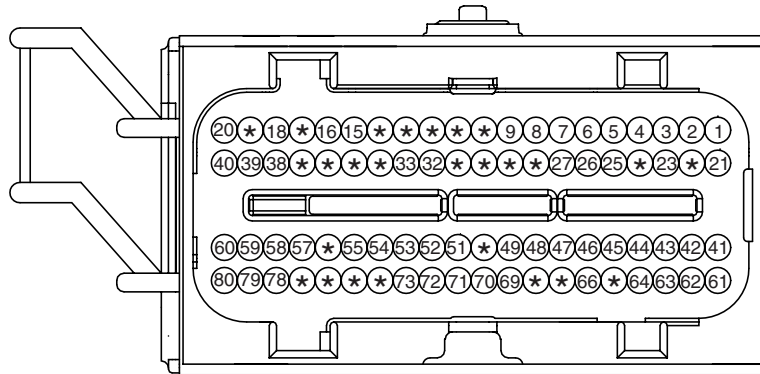

PKD\_ECU\_80F\_B\_1

**C144-B**

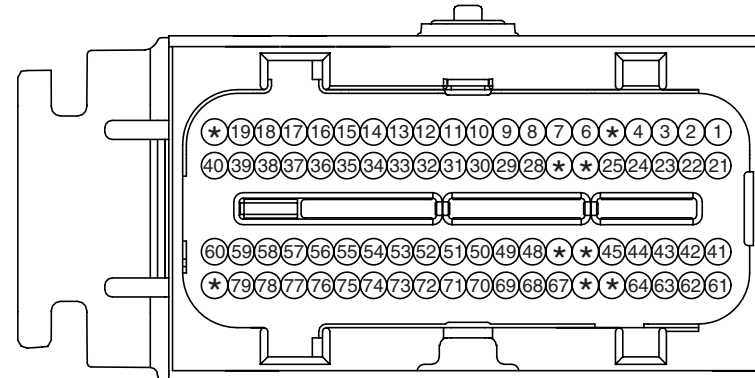

PKD\_ECU\_80F\_B\_2

**C108**

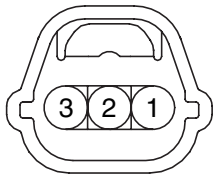

KET\_SSD\_03F\_B\_A

**C109**



KET\_SSD\_10F\_B\_A

**C110**



KET\_SSD\_12F\_B

**C115**

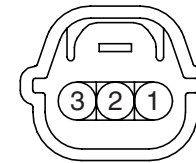

KET\_SSD\_03F\_Gr\_B

**F09**

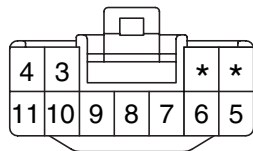

KET\_090II\_11F\_W

**BLANK**

**BLANK**

**BLANK**

**AUTOMATIC TRANSAXLE CONTROL SYSTEM**

**AUTOMATIC TRANSAXLE CONTROL SYSTEM (GSL 3.3L/3.8L) (4)**

**SD450-8**

**MEMO**

AUTOMATIC TRANSAXLE CONTROL SYSTEM (DIESEL) (1)

SD450-9

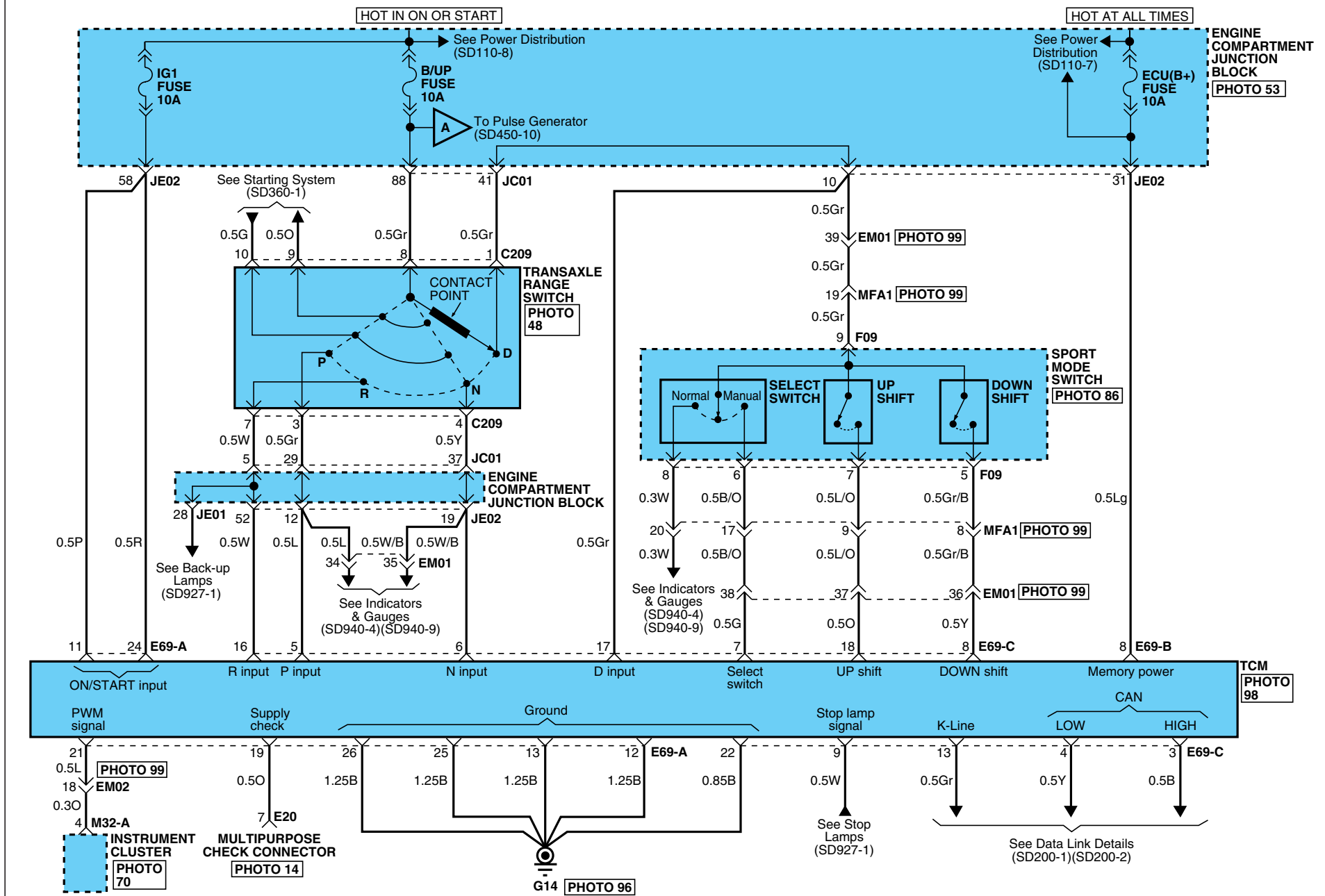

**AUTOMATIC TRANSAXLE CONTROL SYSTEM**

**AUTOMATIC TRANSAXLE CONTROL SYSTEM (DIESEL) (2)**

SD450-10

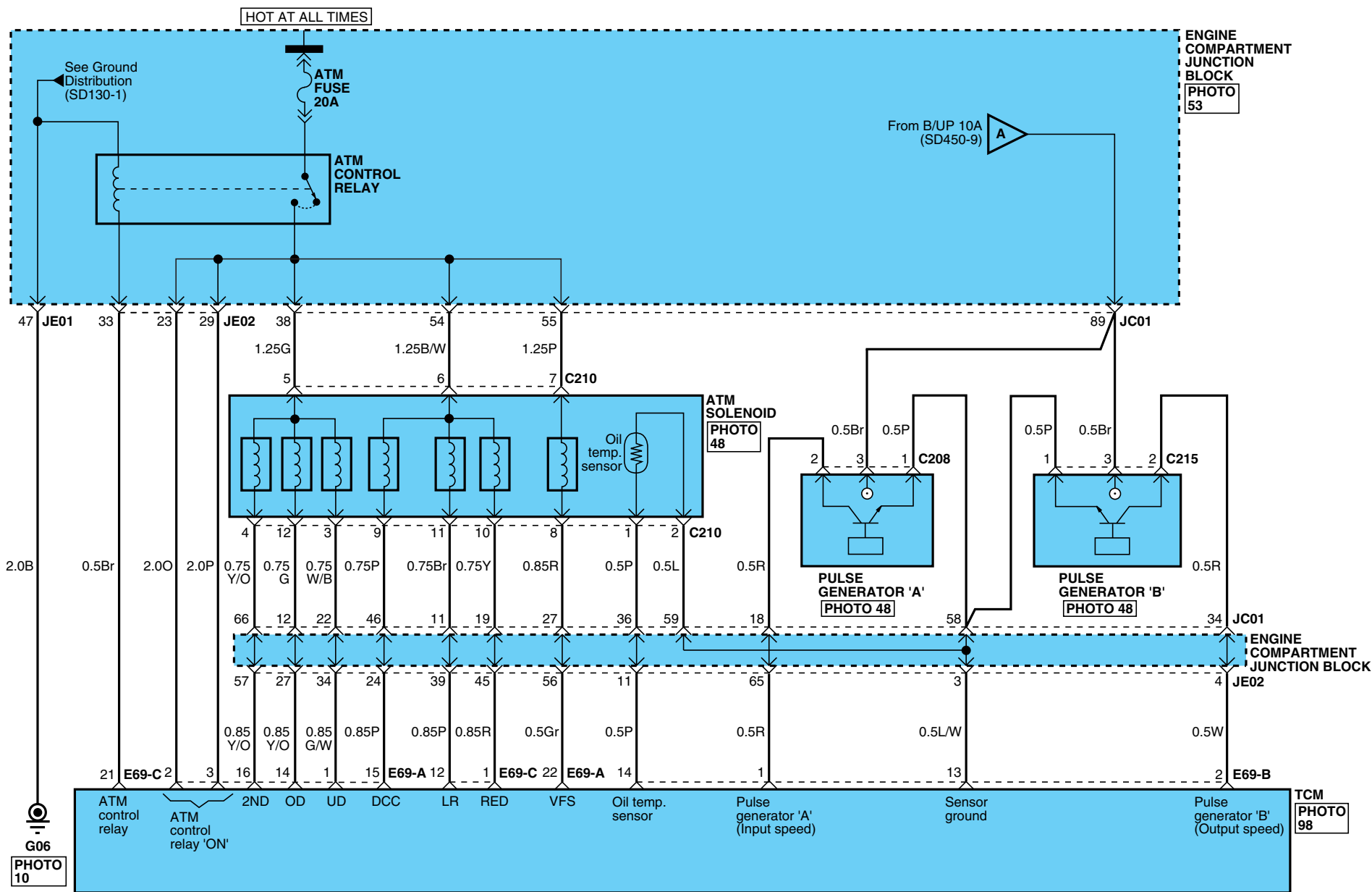

# AUTOMATIC TRANSAXLE CONTROL SYSTEM

## AUTOMATIC TRANSAXLE CONTROL SYSTEM (DIESEL) (3)

SD450-11

**C208**

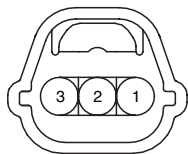

KET\_SSD\_03F\_B\_A

**C209**



KET\_SSD\_10F\_B\_A

**C210**



KET\_SSD\_12F\_B

**C215**

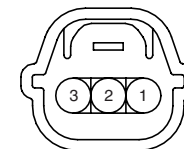

KET\_SSD\_03F\_Gr\_B

**E69-A**

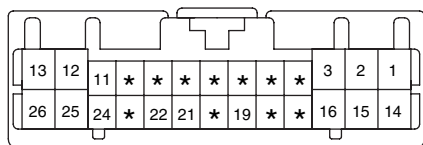

KET\_0407\_26F\_W

**E69-B**

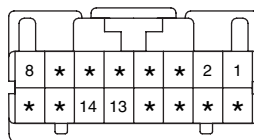

KET\_0407\_16F\_W

**E69-C**

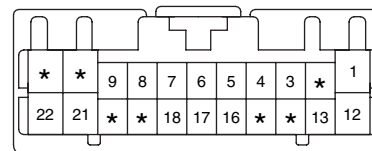

KET\_0407\_22F\_W

**F09**

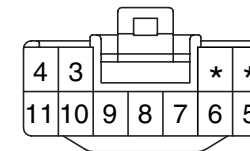

KET\_090II\_11F\_W

**AUTOMATIC TRANSAXLE CONTROL SYSTEM**

**AUTOMATIC TRANSAXLE CONTROL SYSTEM (DIESEL) (4)**

**SD450-12**

**MEMO**

SHIFT LOCK CONTROL SYSTEM (1)

SD452-1

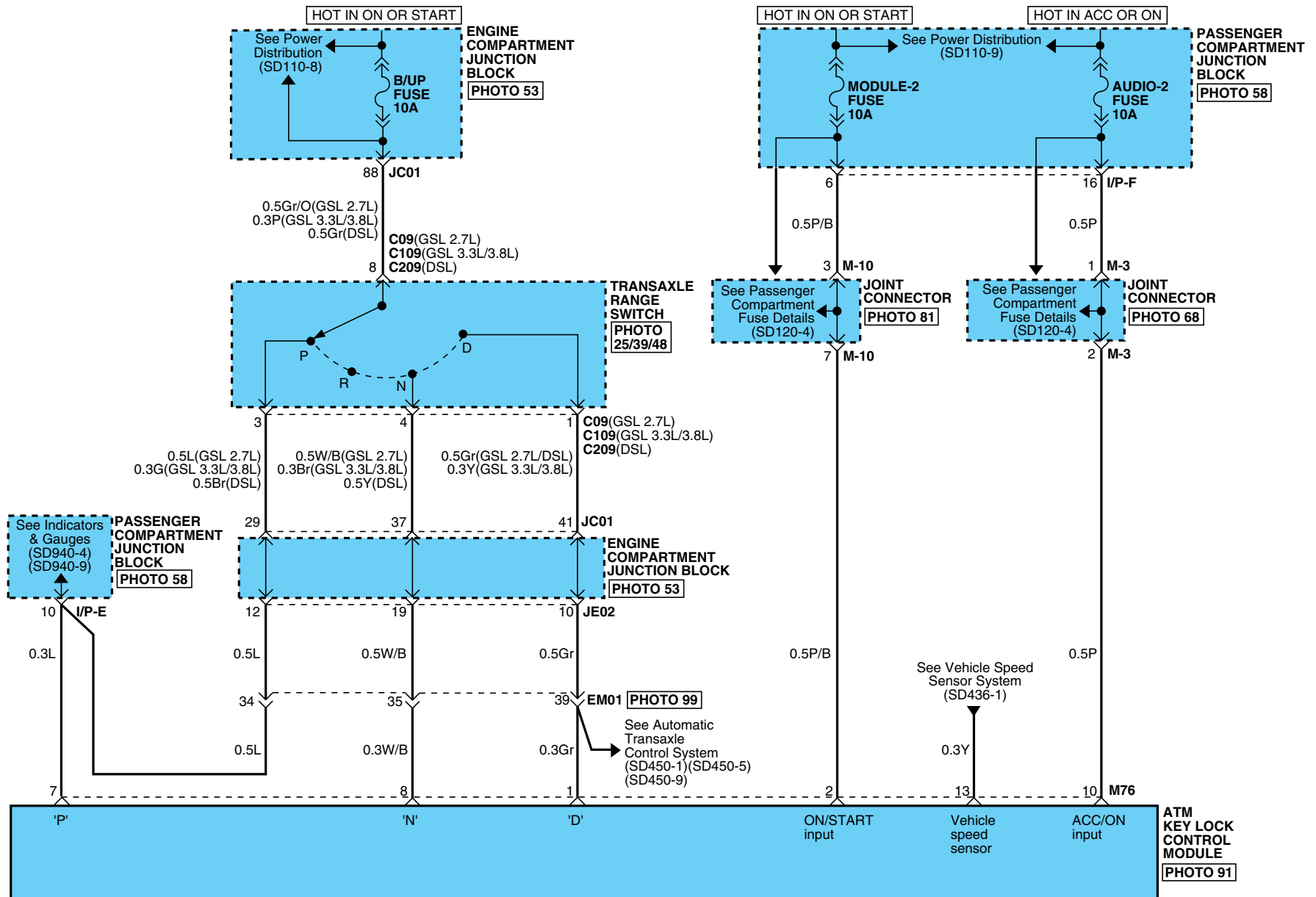



# SHIFT LOCK CONTROL SYSTEM

## SHIFT LOCK CONTROL SYSTEM (2)

SD452-2

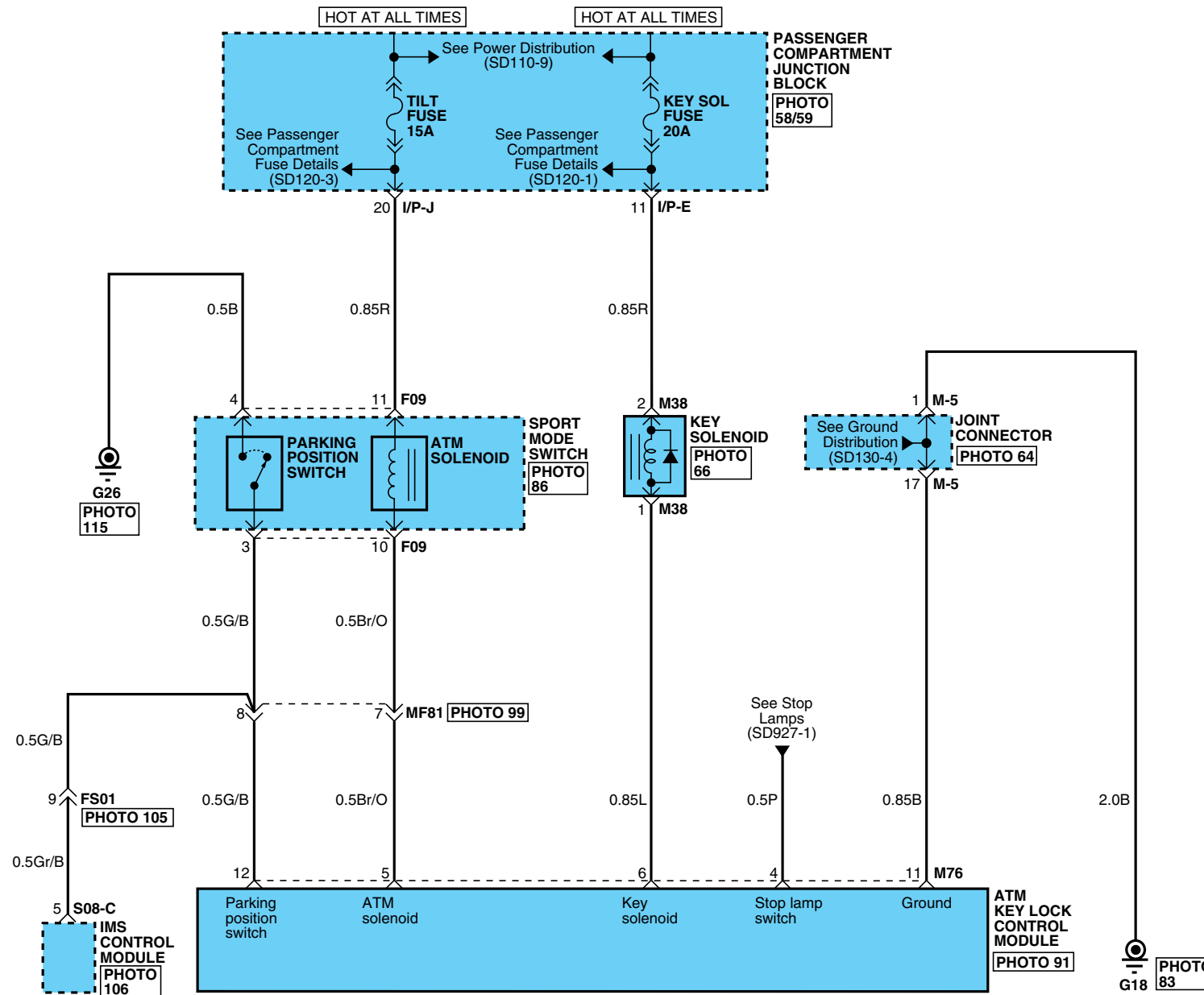

# SHIFT LOCK CONTROL SYSTEM

## SHIFT LOCK CONTROL SYSTEM (3)

SD452-3

**C09/C109/C209**



KET\_SSD\_10F\_B\_A

**F09**

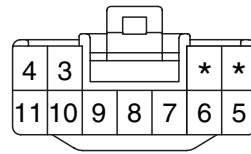

KET\_090II\_11F\_W

**M38**

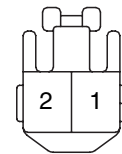

KET\_090II\_02F\_B\_R

**M76**

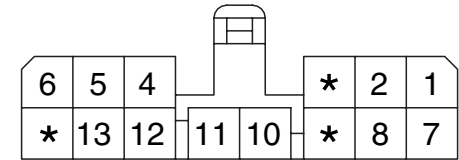

AMP\_070\_14F\_W

**S08-C**

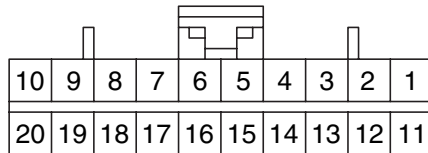

AMP\_040M2\_20F

**BLANK**

**BLANK**

**BLANK**

## SHIFT LOCK CONTROL SYSTEM

SHIFT LOCK CONTROL SYSTEM (4)

SD452-4

MEMO

STEERING TILT & TELESCOPIC SYSTEM (1)

SD564-1

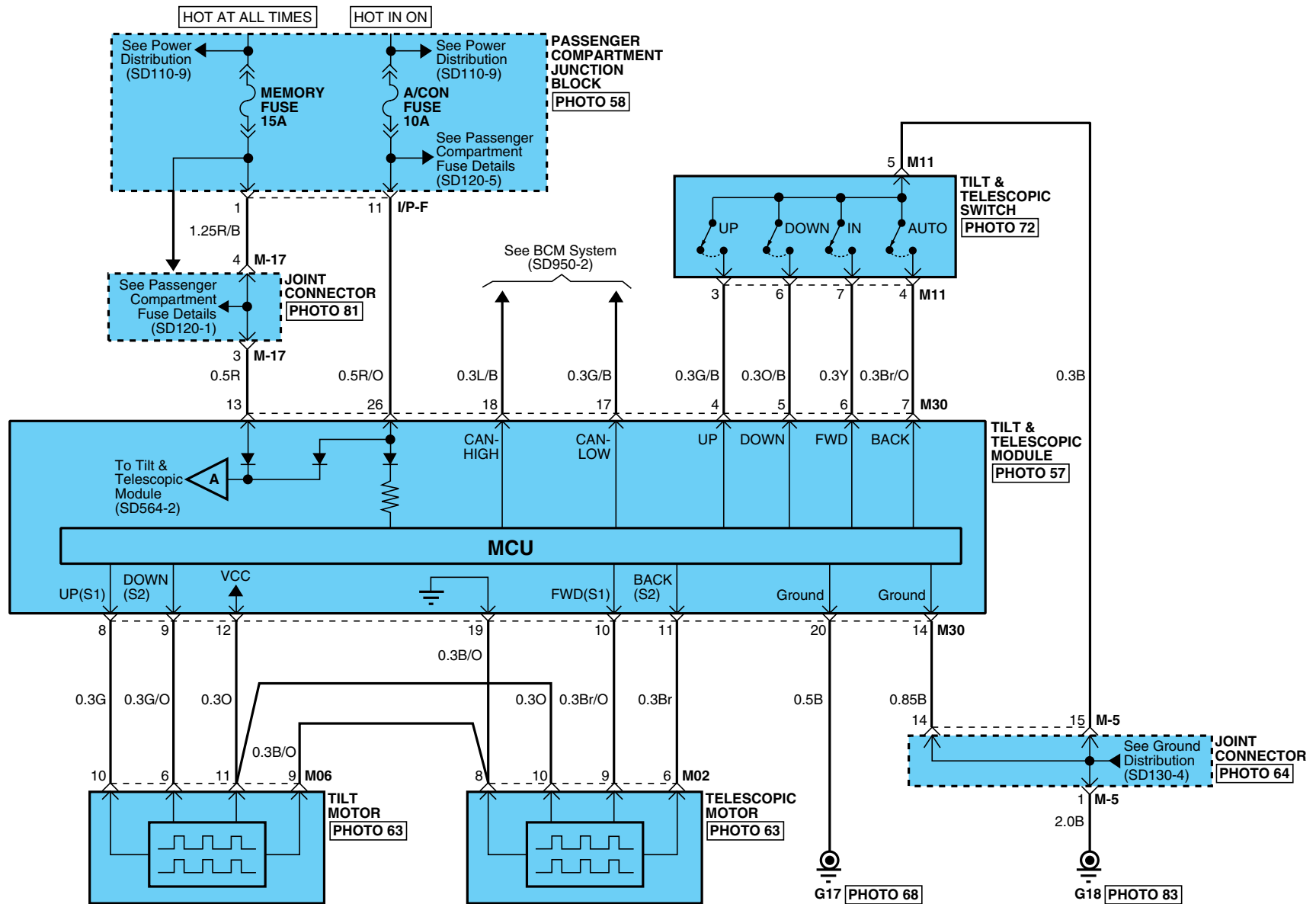

# STEERING TILT & TELESCOPIC SYSTEM

## STEERING TILT & TELESCOPIC SYSTEM (2)

SD564-2

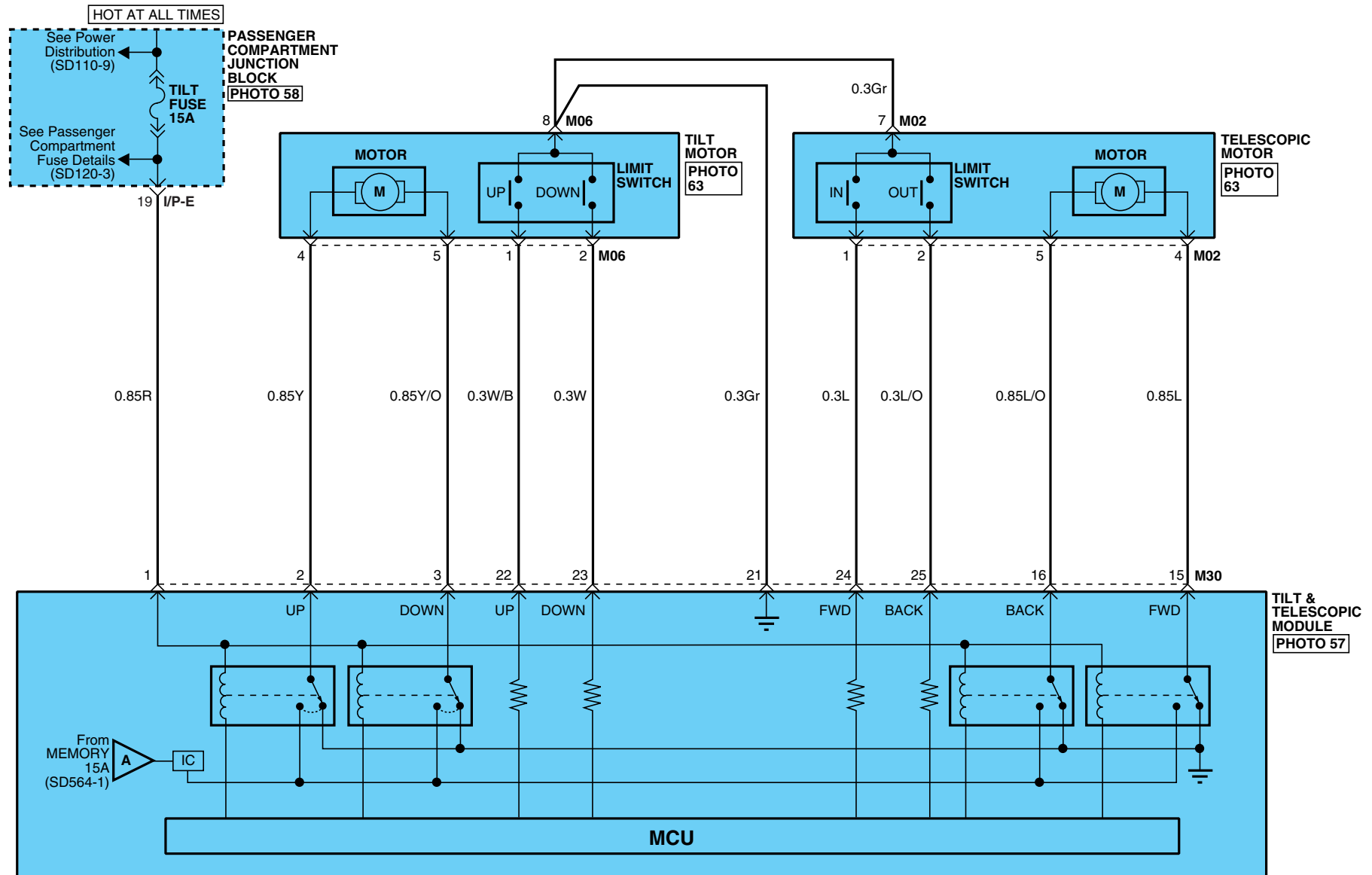

# STEERING TILT & TELESCOPIC SYSTEM

## STEERING TILT & TELESCOPIC SYSTEM (3)

SD564-3

M02

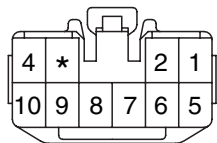

KET\_090II\_10F\_B

M06

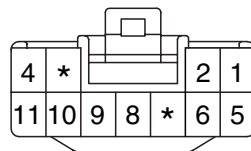

KET\_090II\_11F\_W

M11

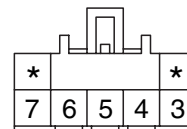

KUM\_CDR\_07F\_W

M30

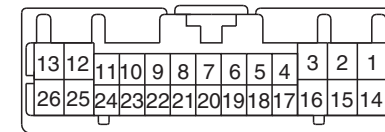

KET\_0407\_26F\_B

**STEERING TILT & TELESCOPIC SYSTEM**

**STEERING TILT & TELESCOPIC SYSTEM (4)**

**SD564-4**

**MEMO**

AIR BAG SYSTEM (SRS) (1)

SD569-1

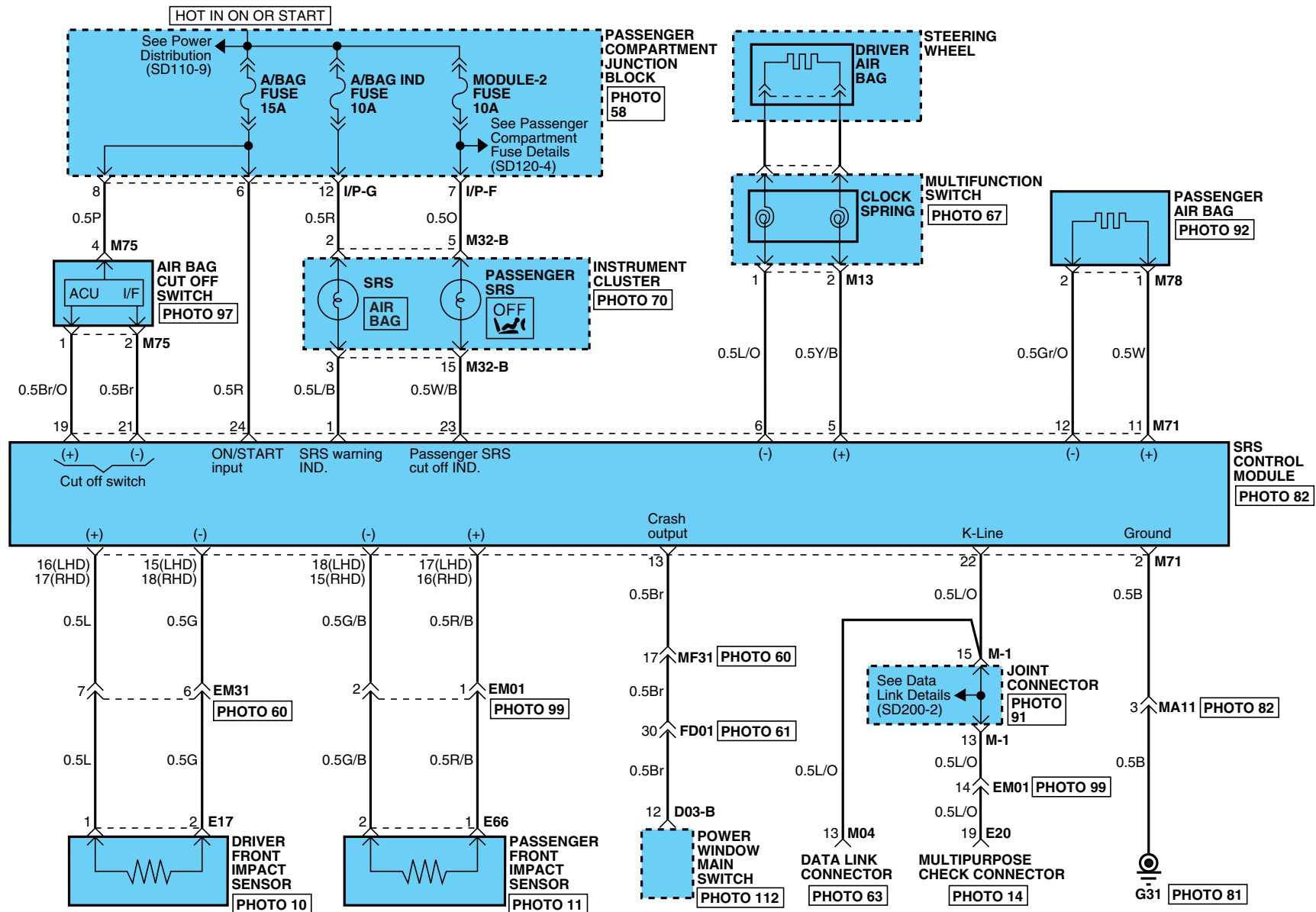



# AIR BAG SYSTEM (SRS)

## AIR BAG SYSTEM (SRS) (2)

SD569-2

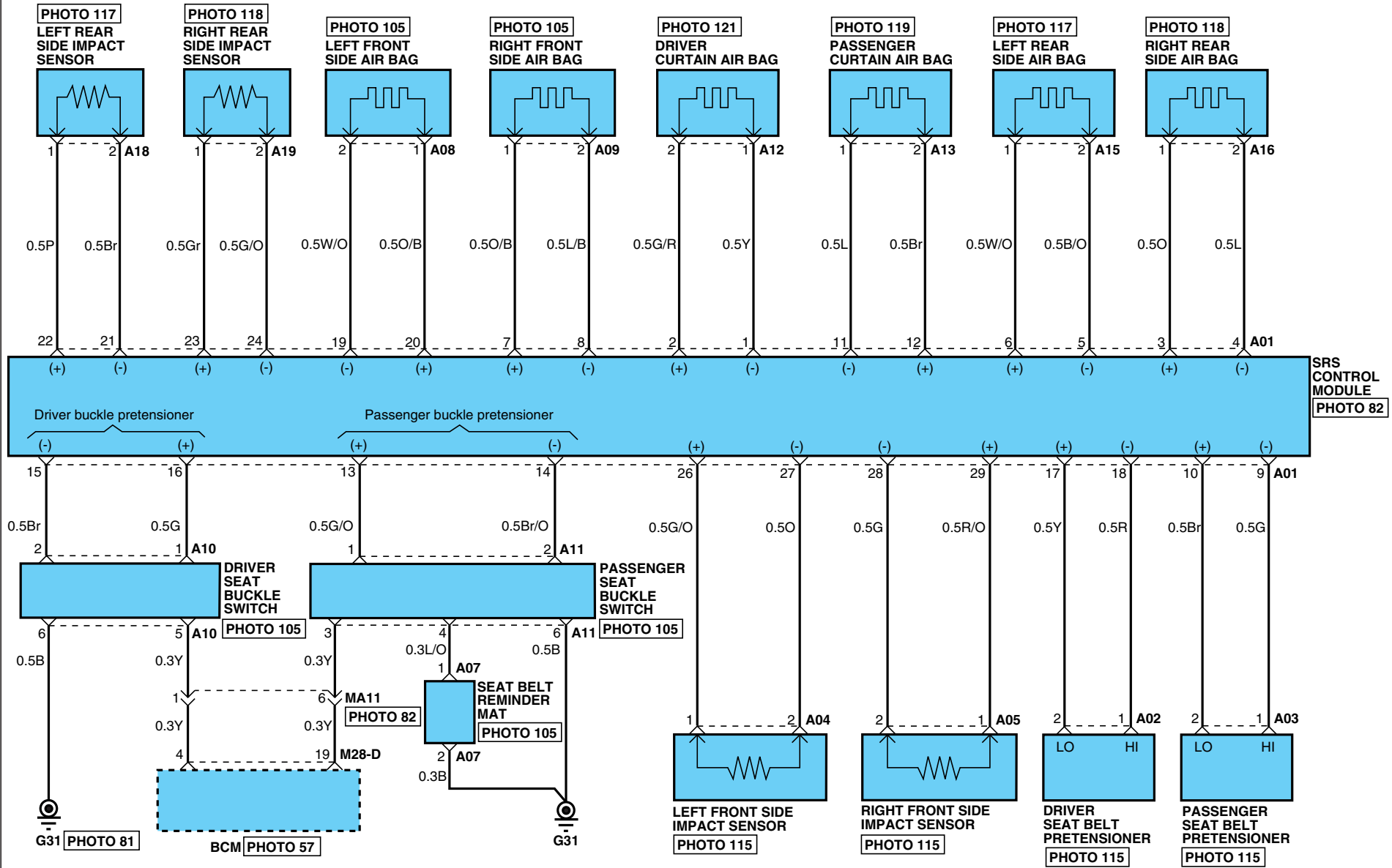

# AIR BAG SYSTEM (SRS)

## AIR BAG SYSTEM (SRS) (3)

SD569-3

**A01**

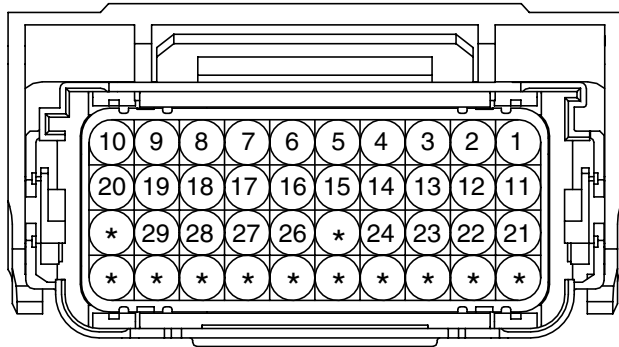

AMP\_ACU\_40F\_GR

**A02**

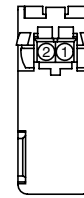

AMP\_SQUIB\_02F\_Y

**A03**

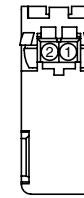

AMP\_SQUIB\_02F\_Y

**A04**

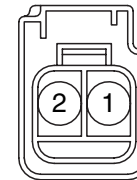

EPC\_E4014\_02F\_B

**A05**



EPC\_E4014\_02F\_B

**A07**

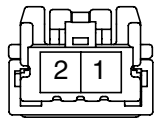

YAZ\_TK\_02F\_W

**A08**

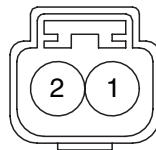

YAZ\_040WP\_02F\_Y

**A09**

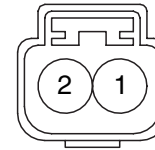

YAZ\_040WP\_02F\_Y

**A10**

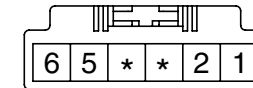

AMP\_ABAG\_06F\_Y

**A11**

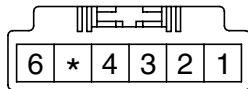

AMP\_ABAG\_06F\_Y

**A12**

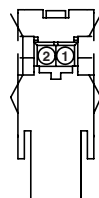

APL\_ABG\_02F\_Y

**A13**

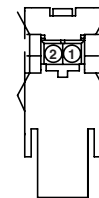

APL\_ABG\_02F\_Y

**A15**

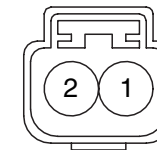

YAZ\_040WP\_02F\_Y

**A16**

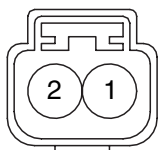

YAZ\_040WP\_02F\_Y

**A18**

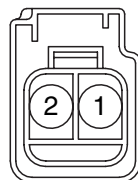

EPC\_E4014\_02F\_B

**A19**

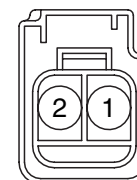

EPC\_E4014\_02F\_B

**E17**



SUM\_060WP\_02F\_B

# AIR BAG SYSTEM (SRS)

## AIR BAG SYSTEM (SRS) (4)

SD569-4

**E66**



SUM\_060WP\_02F\_B

**M13**

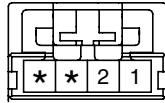

YAZ\_040\_04F\_Y

**M28-D**

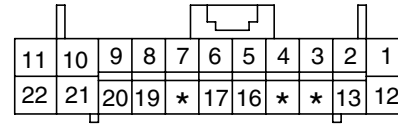

AMP\_0407\_22F\_W\_HD

**M32-B**

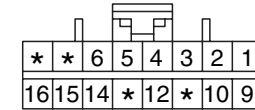

AMP\_040M2\_16F\_B

**M71**



AMP\_ACU\_24F\_B

**M75**

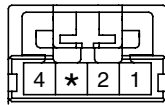

AMP\_MQS\_04F\_Y\_040

**M78**

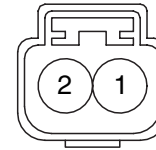

YAZ\_040WP\_02F\_Y

**BLANK**

ABS (ANTI-LOCK BRAKE) SYSTEM (1)

SD587-1

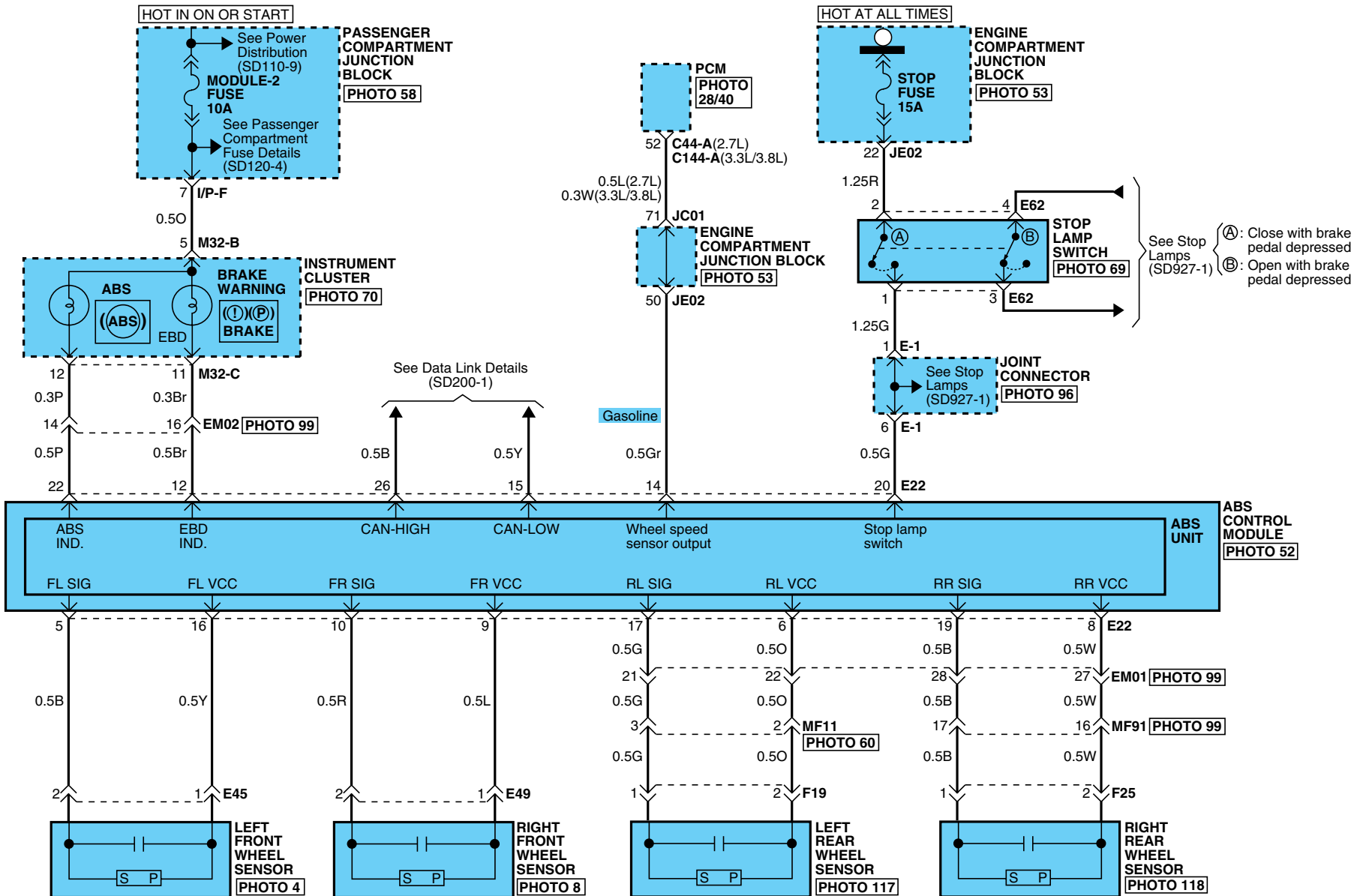

# ABS (ANTI-LOCK BRAKE) SYSTEM

## ABS (ANTI-LOCK BRAKE) SYSTEM (2)

SD587-2

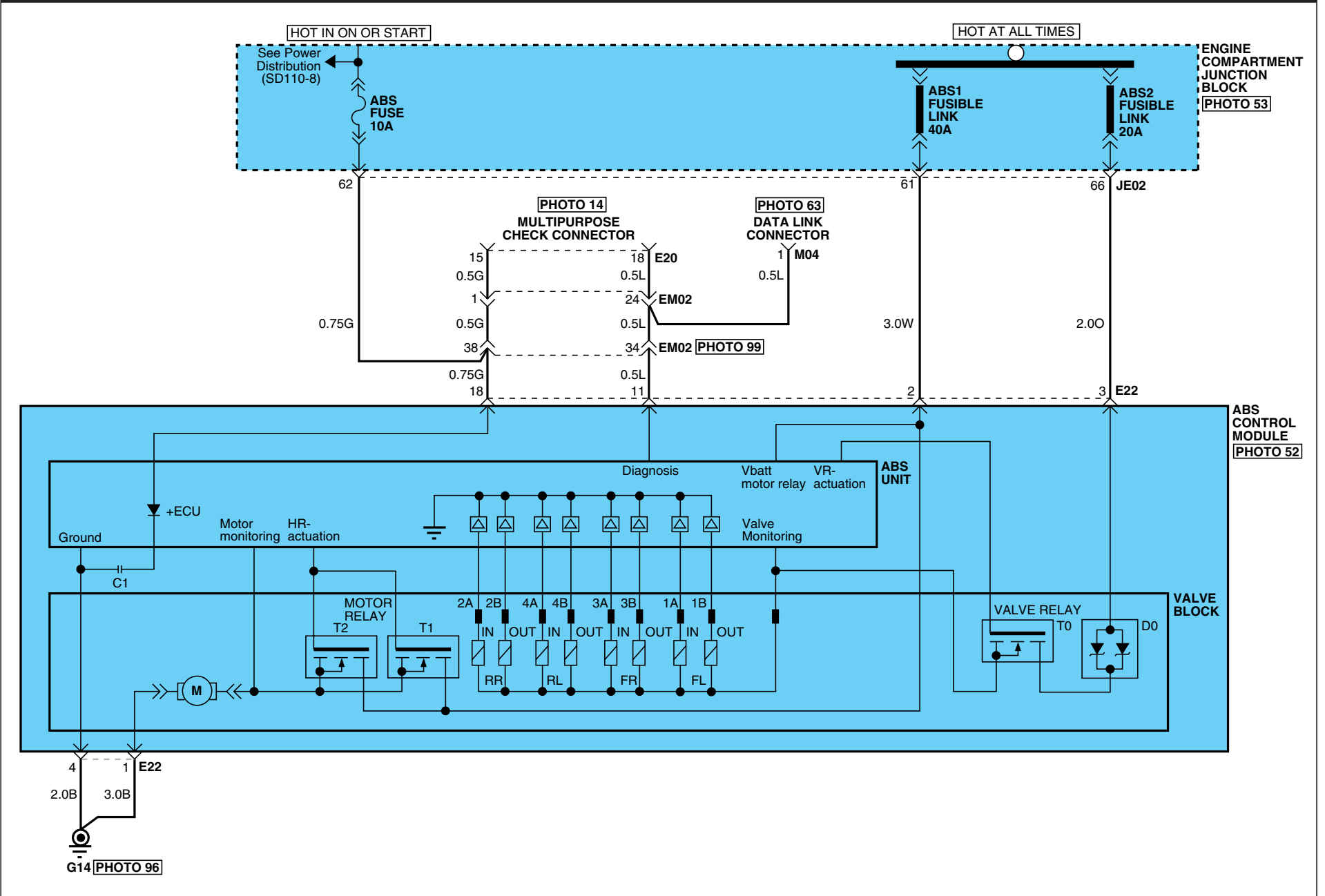

# ABS (ANTI-LOCK BRAKE) SYSTEM

## ABS (ANTI-LOCK BRAKE) SYSTEM (3)

SD587-3

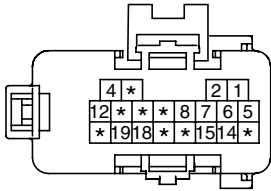
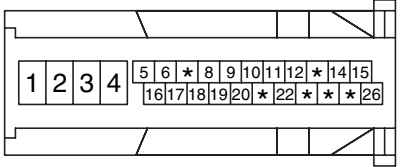
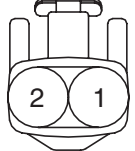
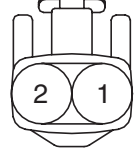
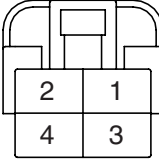
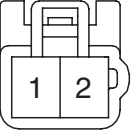
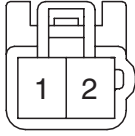
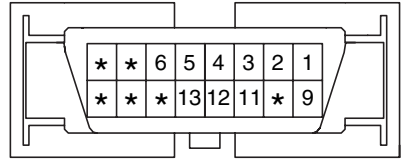
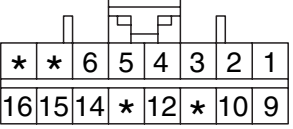
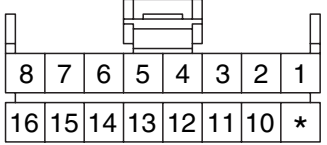
<p><b>E20</b></p>  <p>KET_DIAG_20F_B_BRK_A</p>	<p><b>E22</b></p>  <p>BOS_ABS_26F_B_L</p>	<p><b>E45</b></p>  <p>KET_090IWP_02F_B</p>	<p><b>E49</b></p>  <p>KET_090IWP_02F_B</p>
<p><b>E62</b></p>  <p>KET_250DL_04F_W</p>	<p><b>F19</b></p>  <p>YAZ_090II_02M_W_R</p>	<p><b>F25</b></p>  <p>YAZ_090II_02M_W_R</p>	<p><b>M04</b></p>  <p>MLX_OBDII_16F_B_SIN</p>
<p><b>M32-B</b></p>  <p>AMP_040M2_16F_B</p>	<p><b>M32-C</b></p>  <p>AMP_040M1_16F_B</p>	<p><b>BLANK</b></p>	<p><b>BLANK</b></p>

## ABS (ANTI-LOCK BRAKE) SYSTEM

ABS (ANTI-LOCK BRAKE) SYSTEM (4)

SD587-4

MEMO

# ESP (ELECTRONIC STABILITY PROGRAM) SYSTEM

EE75A9BF

## ESP (ELECTRONIC STABILITY PROGRAM) SYSTEM (1)

SD589-1

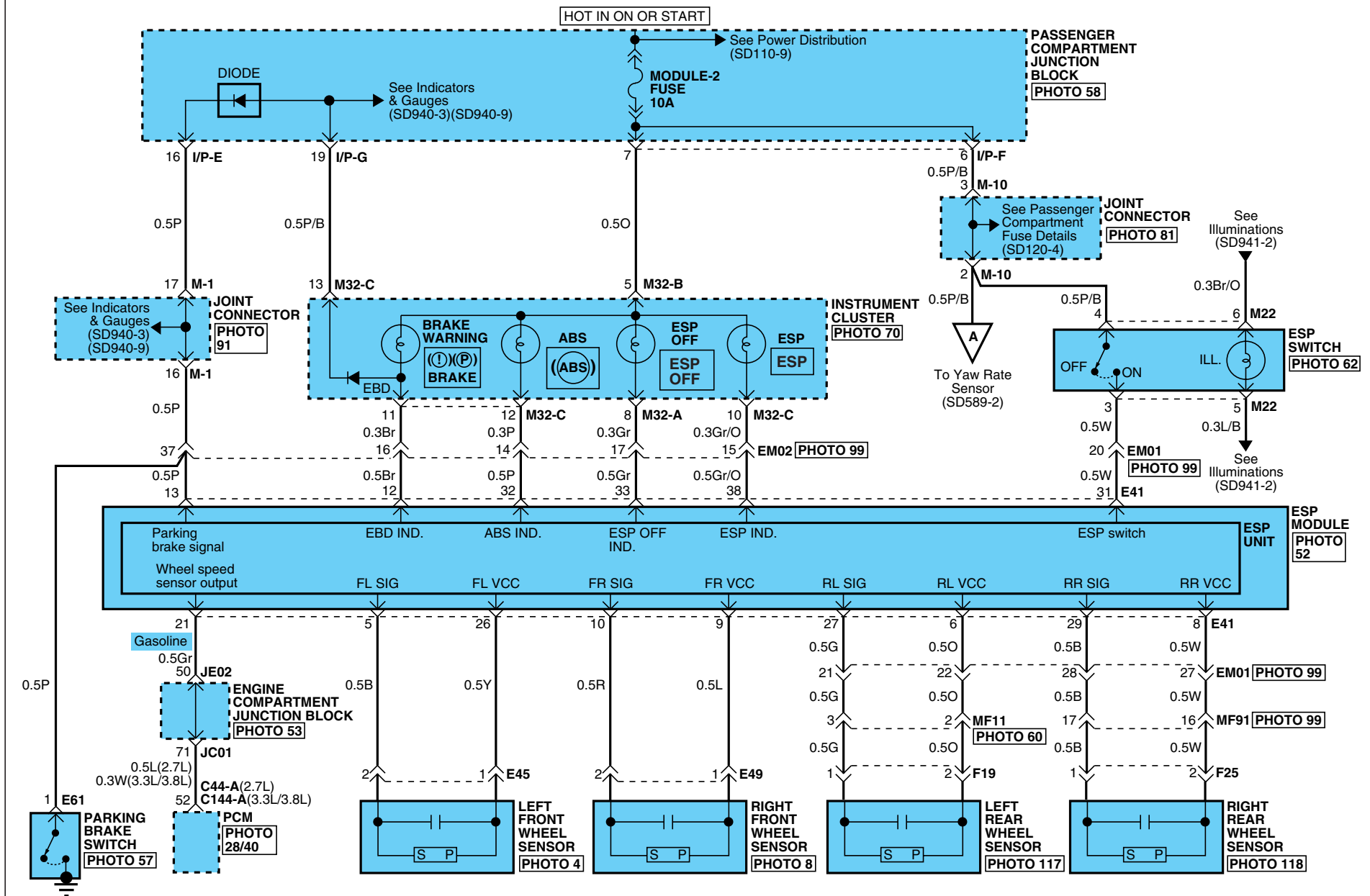



# ESP (ELECTRONIC STABILITY PROGRAM) SYSTEM

## ESP (ELECTRONIC STABILITY PROGRAM) SYSTEM (2)

SD589-2

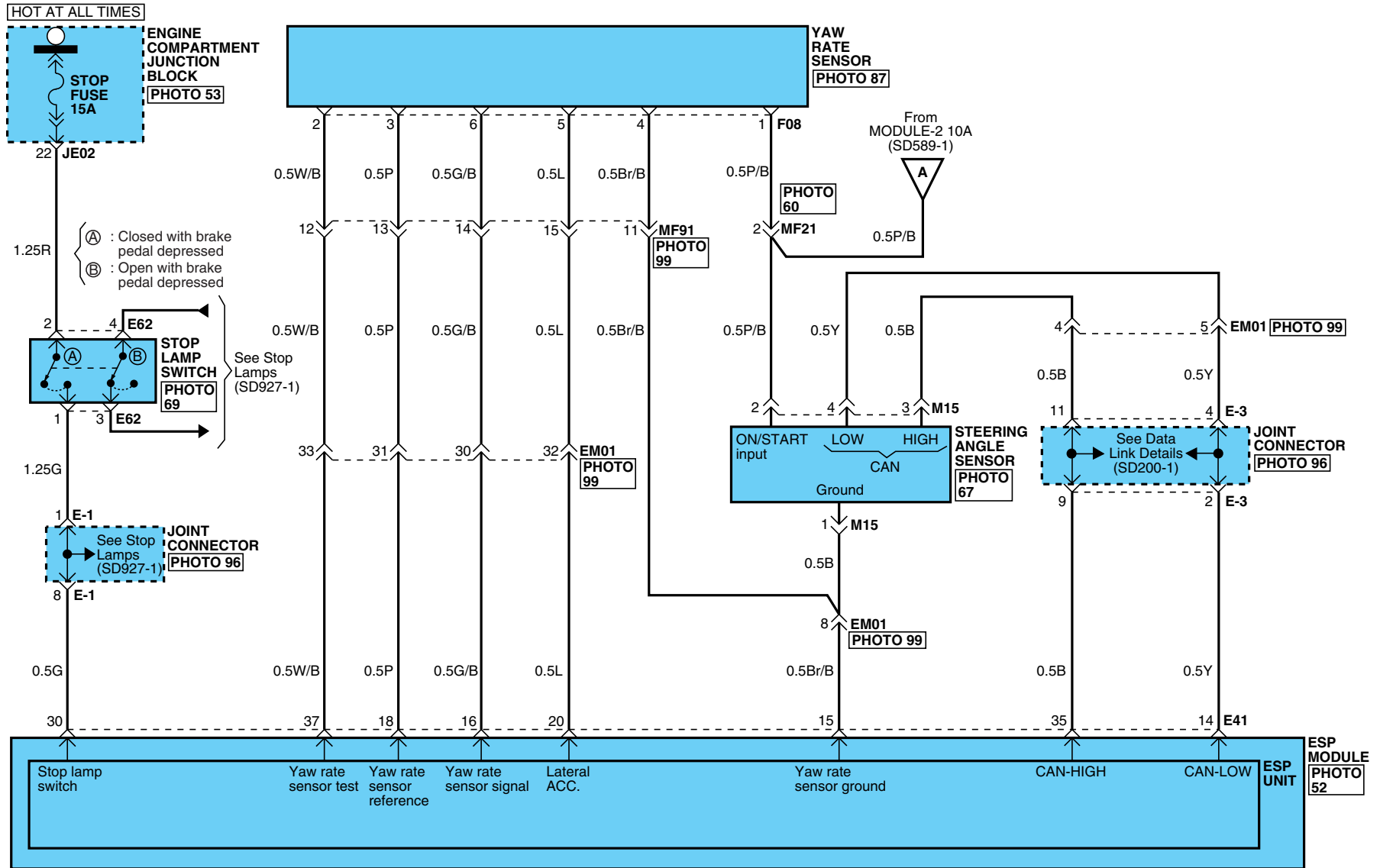

# ESP (ELECTRONIC STABILITY PROGRAM) SYSTEM

## ESP (ELECTRONIC STABILITY PROGRAM) SYSTEM (3)

SD589-3

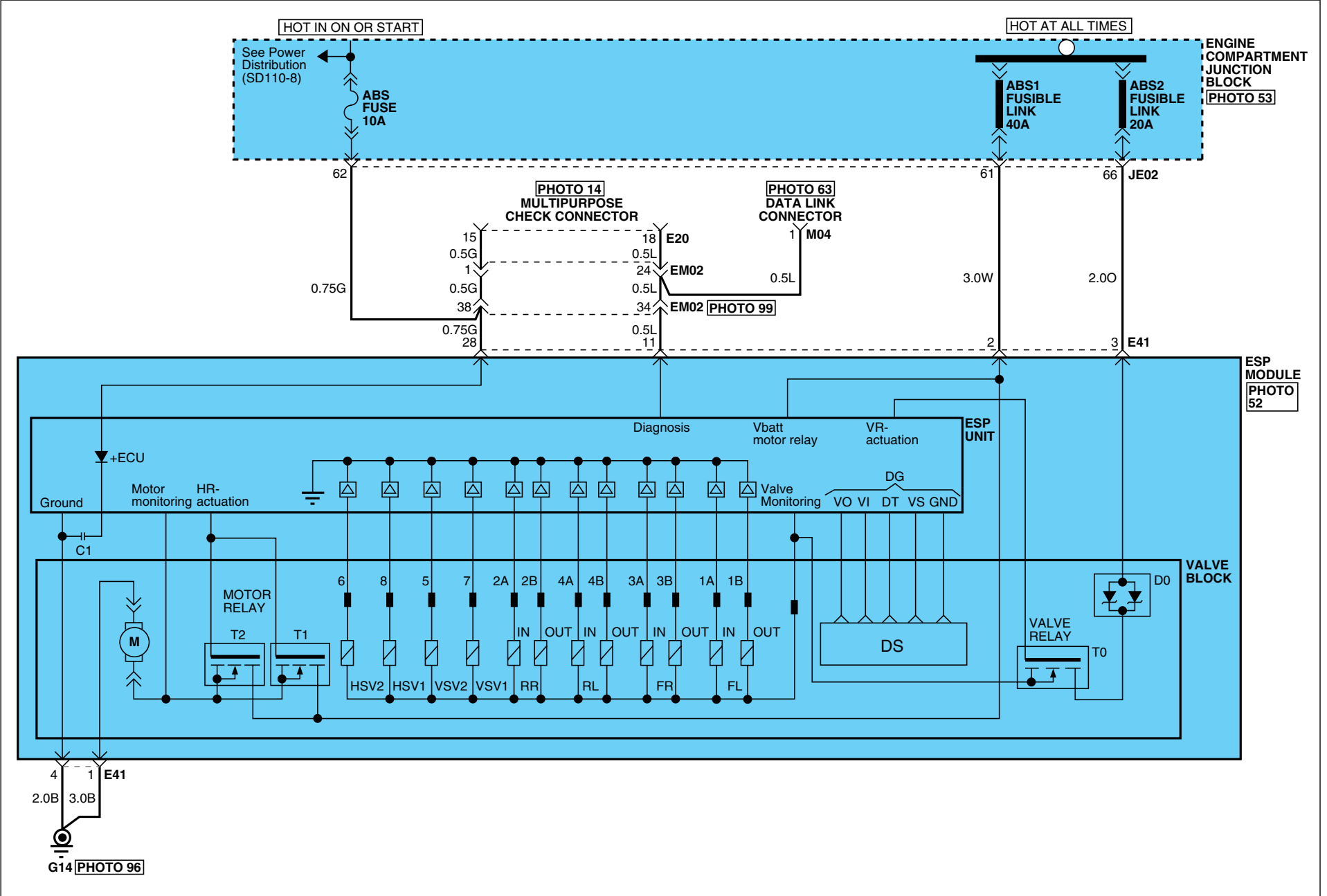

# ESP (ELECTRONIC STABILITY PROGRAM) SYSTEM

## ESP (ELECTRONIC STABILITY PROGRAM) SYSTEM (4)

SD589-4

<p><b>E20</b></p> <p>KET_DIAG_20F_B_BRK_A</p>	<p><b>E41</b></p> <p>BOS_ESP_46F_B_L</p>		<p><b>E45</b></p> <p>KET_090IWP_02F_B</p>
<p><b>E49</b></p> <p>KET_090IWP_02F_B</p>	<p><b>E61</b></p> <p>KET_250_01F_B_CLIP1</p>	<p><b>E62</b></p> <p>KET_250DL_04F_W</p>	<p><b>F08</b></p> <p>AMP_MQSWP_06F_B_1</p>
<p><b>F19</b></p> <p>YAZ_090II_02M_W_R</p>	<p><b>F25</b></p> <p>YAZ_090II_02M_W_R</p>	<p><b>M04</b></p> <p>MLX_OBDII_16F_B_SIN</p>	<p><b>M15</b></p> <p>AMP_MQS_04F_Y_040</p>
<p><b>M22</b></p> <p>KET_090II_06F_G_SW</p>	<p><b>M32-A</b></p> <p>AMP_040M2_20F_B</p>	<p><b>M32-B</b></p> <p>AMP_040M2_16F_B</p>	<p><b>M32-C</b></p> <p>AMP_040M1_16F_B</p>
Empty space for additional diagrams			

FUEL FILLER DOOR & TRUNK LID OPENER SYSTEM (1)

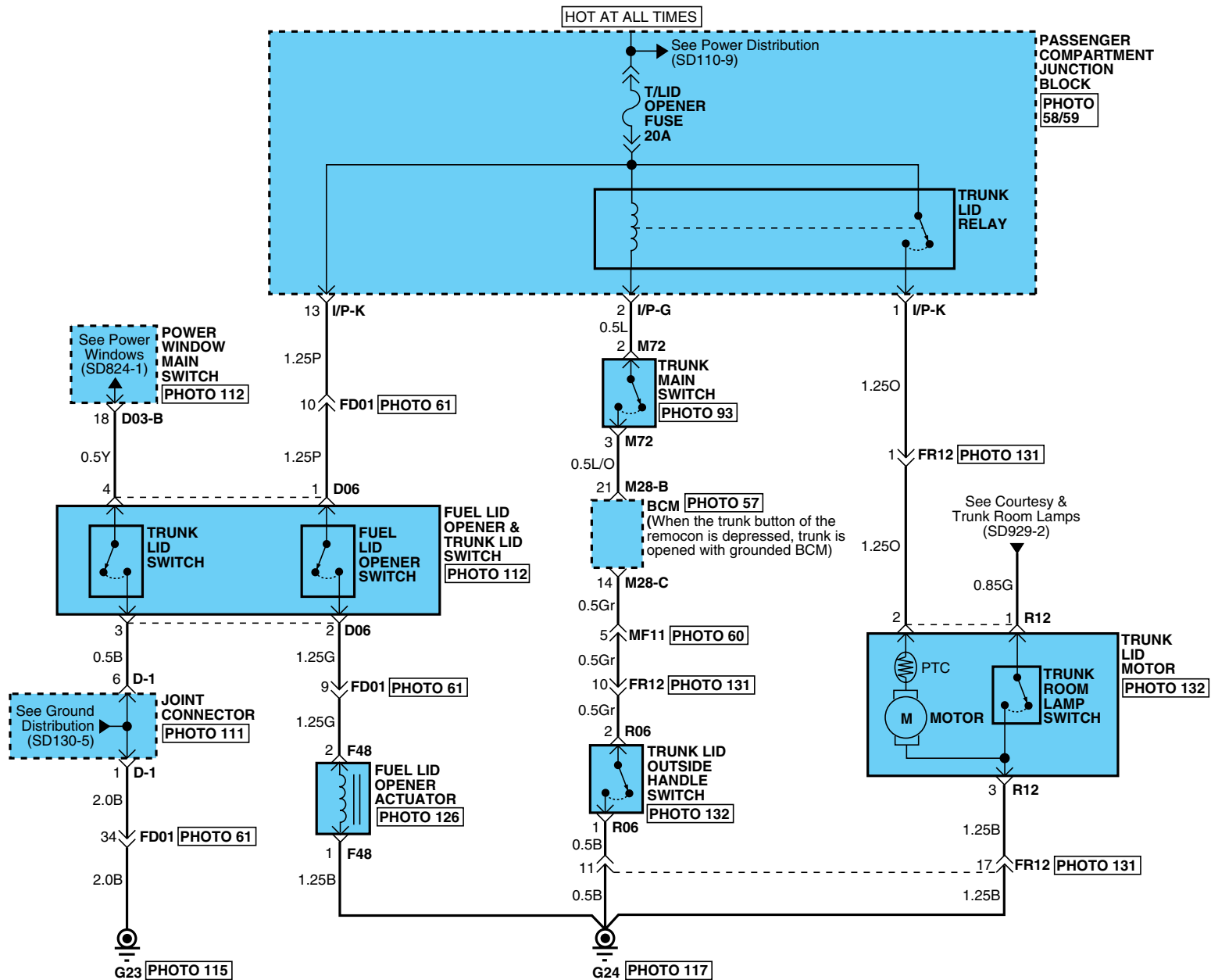

# FUEL FILLER DOOR & TRUNK LID OPENER SYSTEM

## FUEL FILLER DOOR & TRUNK LID OPENER SYSTEM (2)

SD812-2

**D06**

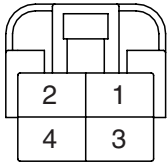

KET\_250DL\_04F\_W

**F48**



KET\_250\_02F\_W

**M28-B**

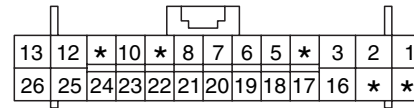

AMP\_0407\_26F\_W\_HD

**M28-C**

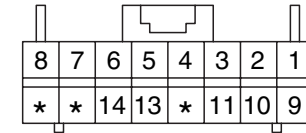

AMP\_0407\_16F\_W\_040

**M72**

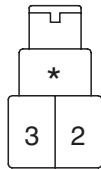

KET\_250\_03F\_W

**R06**

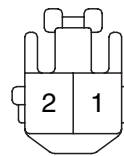

KET\_090II\_02F\_W\_L

**R12**

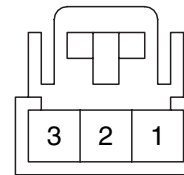

AMP\_070\_03F\_W\_HOR

**BLANK**

# POWER DOOR LOCK SYSTEM

EC9CC2F3

## POWER DOOR LOCK SYSTEM (1)

SD813-1

**LHD**

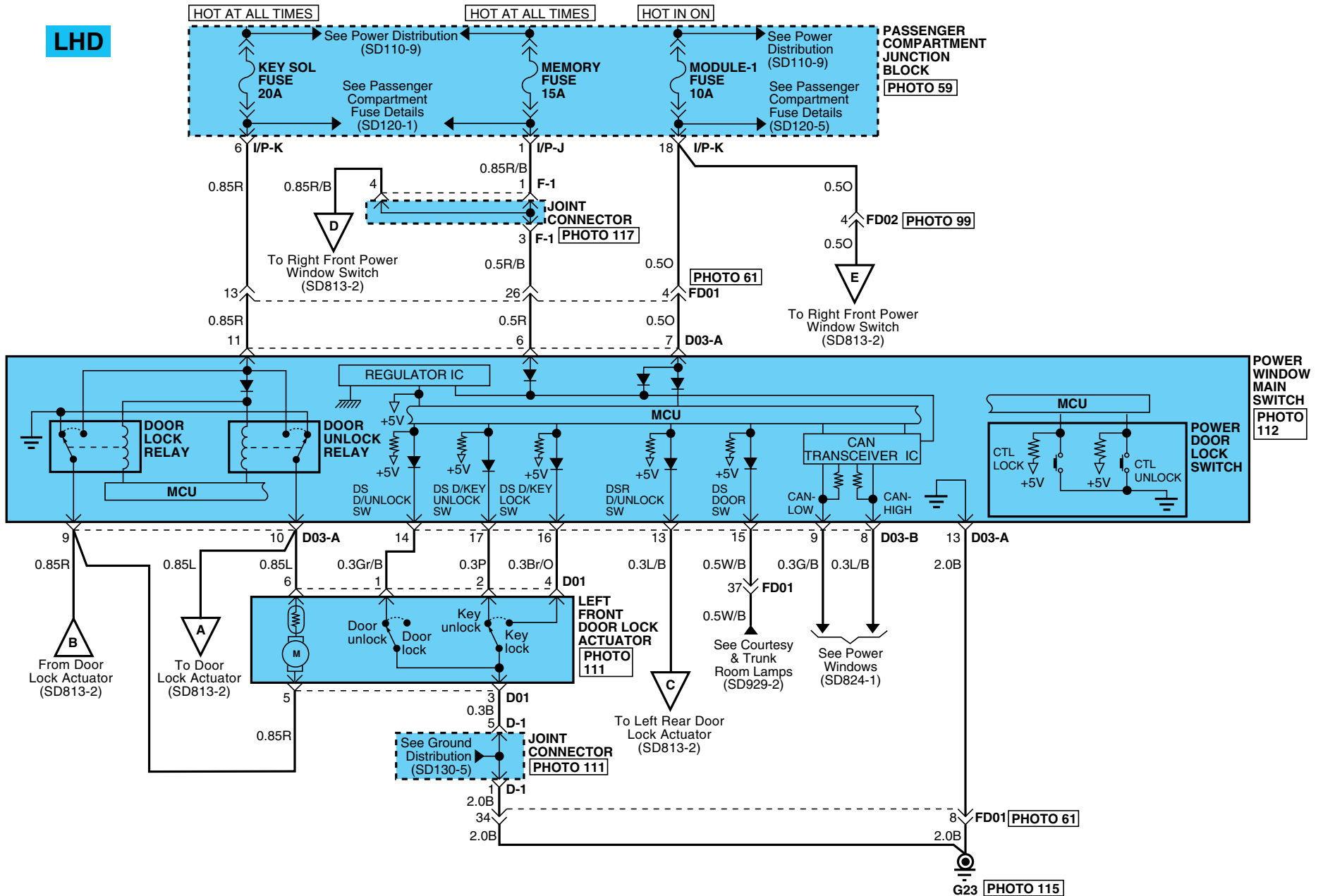

# POWER DOOR LOCK SYSTEM

## POWER DOOR LOCK SYSTEM (2)

SD813-2

**LHD**

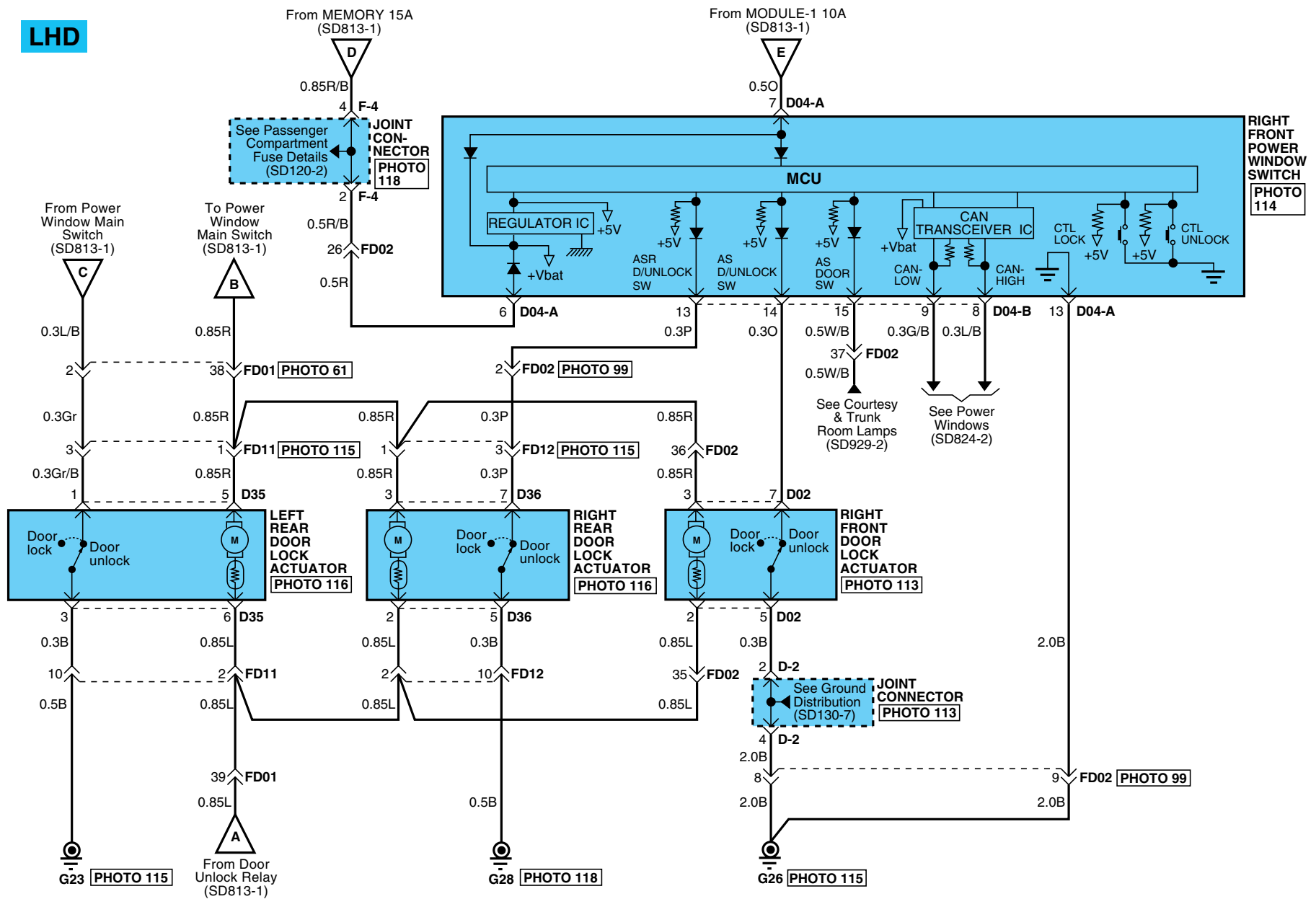

# POWER DOOR LOCK SYSTEM

## POWER DOOR LOCK SYSTEM (3)

SD813-3

RHD

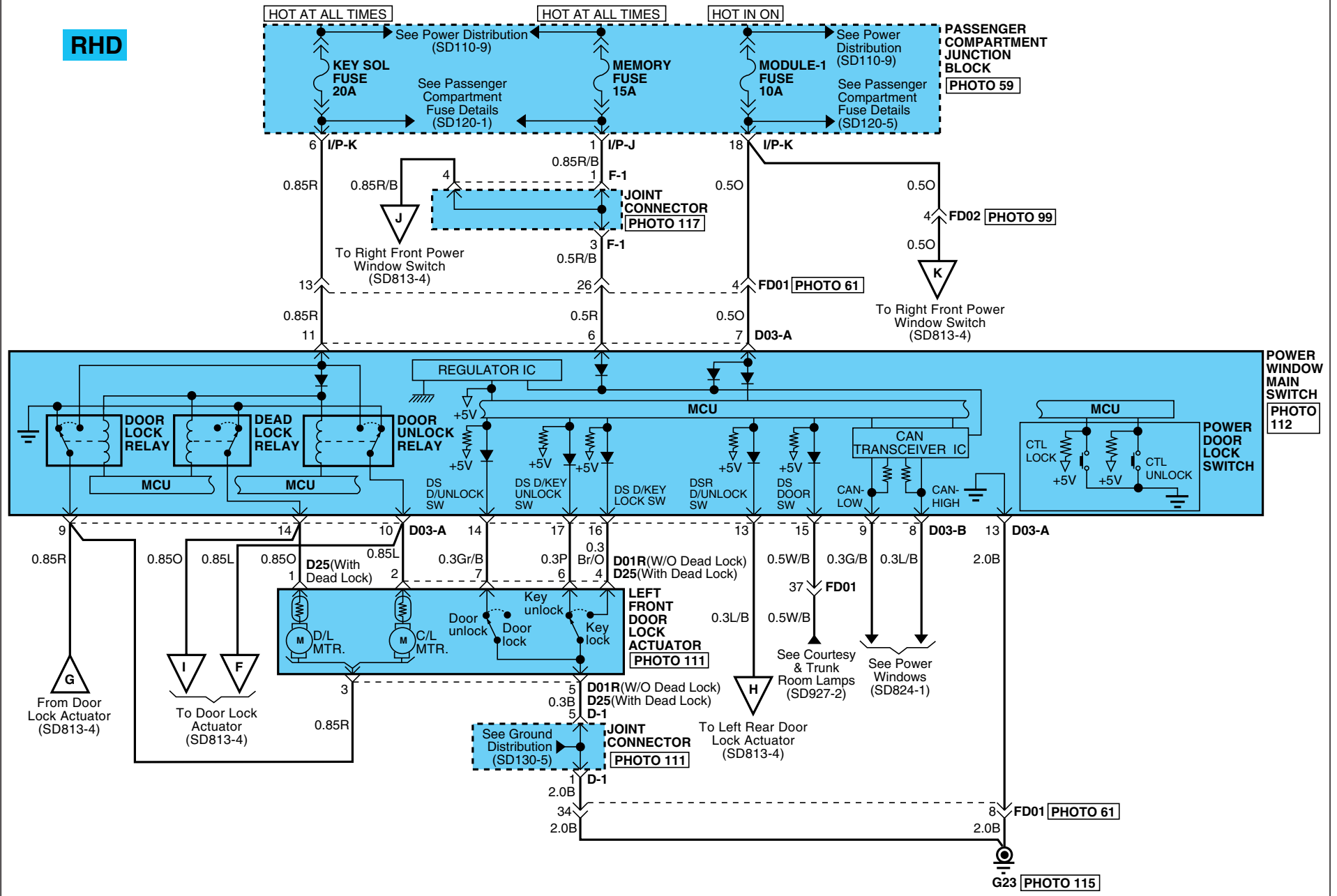



# POWER DOOR LOCK SYSTEM

## POWER DOOR LOCK SYSTEM (4)

SD813-4

**RHD**

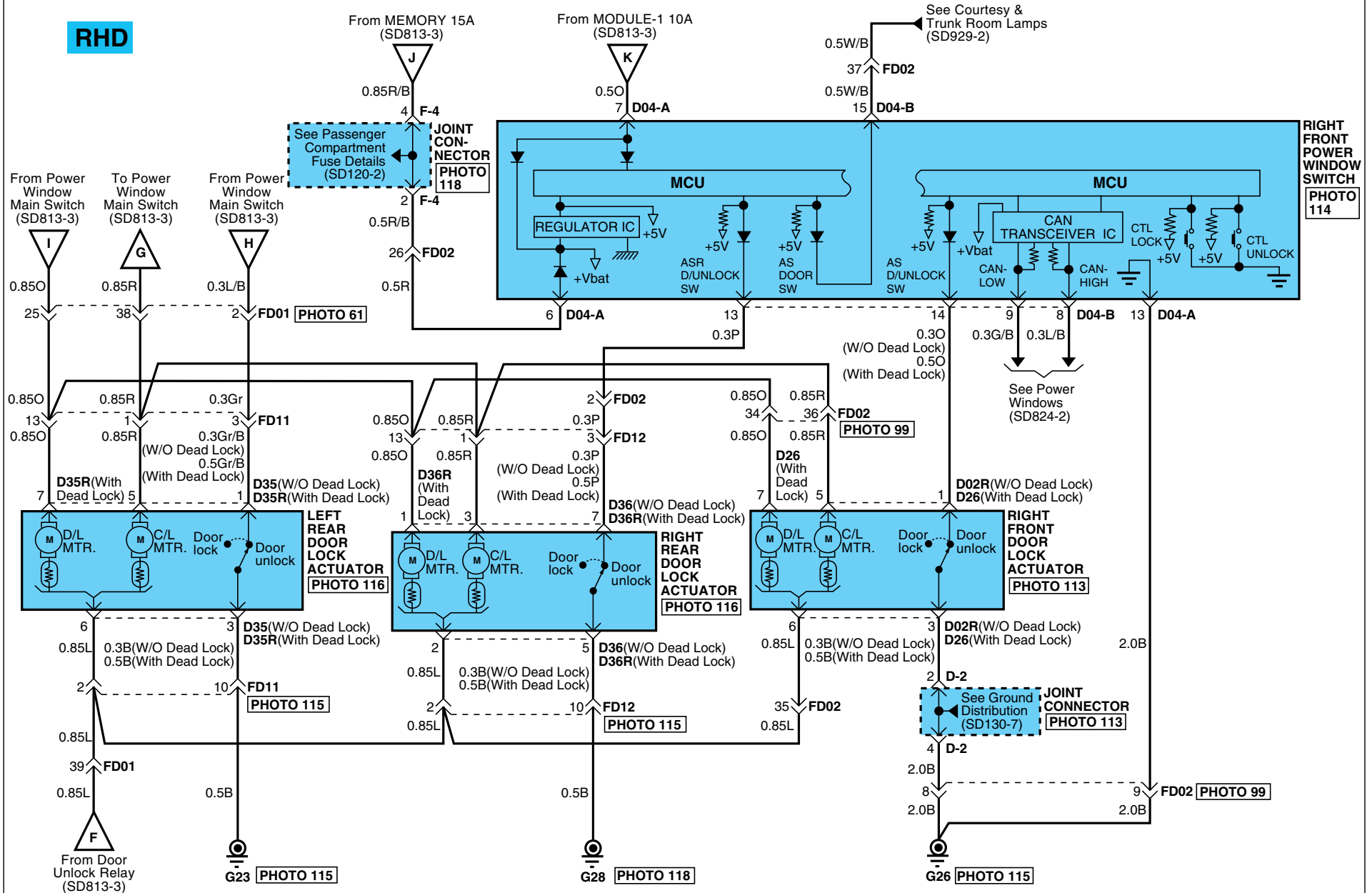

**POWER DOOR LOCK SYSTEM**

**POWER DOOR LOCK SYSTEM (5)**

**SD813-5**

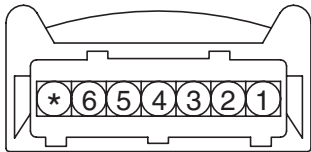
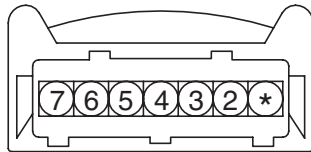
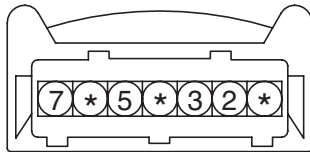
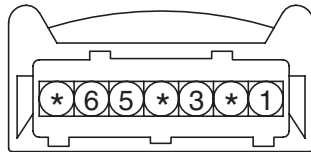
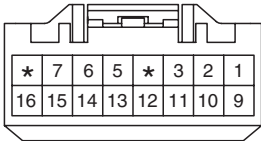
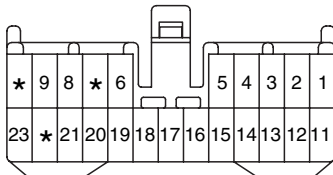
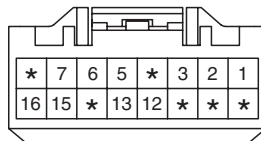
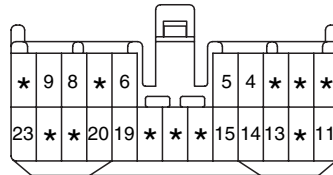
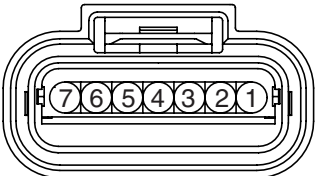
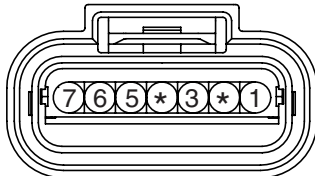
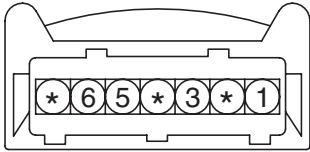
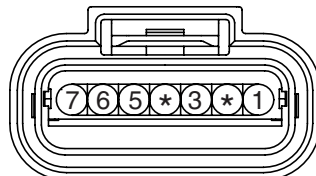
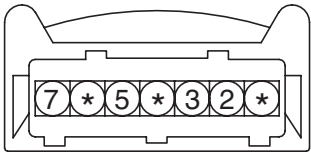
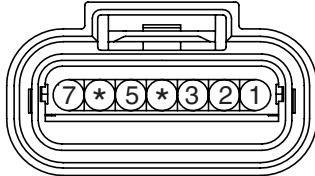
<p><b>D01</b></p>  <p>AMP_110WP_07F_B_DR</p>	<p><b>D01R</b></p>  <p>AMP_110WP_07F_B_DR</p>	<p><b>D02</b></p>  <p>AMP_110WP_07F_B_DR</p>	<p><b>D02R</b></p>  <p>AMP_110WP_07F_B_DR</p>
<p><b>D03-A</b></p>  <p>AMP_090III_16F_W</p>	<p><b>D03-B</b></p>  <p>KET_050_23F_W</p>	<p><b>D04-A</b></p>  <p>AMP_090III_16F_W</p>	<p><b>D04-B</b></p>  <p>KET_050_23F_W</p>
<p><b>D25</b></p>  <p>AMP_025WP_07F_B</p>	<p><b>D26</b></p>  <p>AMP_025WP_07F_B</p>	<p><b>D35</b></p>  <p>AMP_110WP_07F_B_DR</p>	<p><b>D35R</b></p>  <p>AMP_025WP_07F_B</p>
<p><b>D36</b></p>  <p>AMP_110WP_07F_B_DR</p>	<p><b>D36R</b></p>  <p>AMP_025WP_07F_B</p>	<p><b>BLANK</b></p>	<p><b>BLANK</b></p>

## POWER DOOR LOCK SYSTEM

POWER DOOR LOCK SYSTEM (6)

SD813-6

MEMO

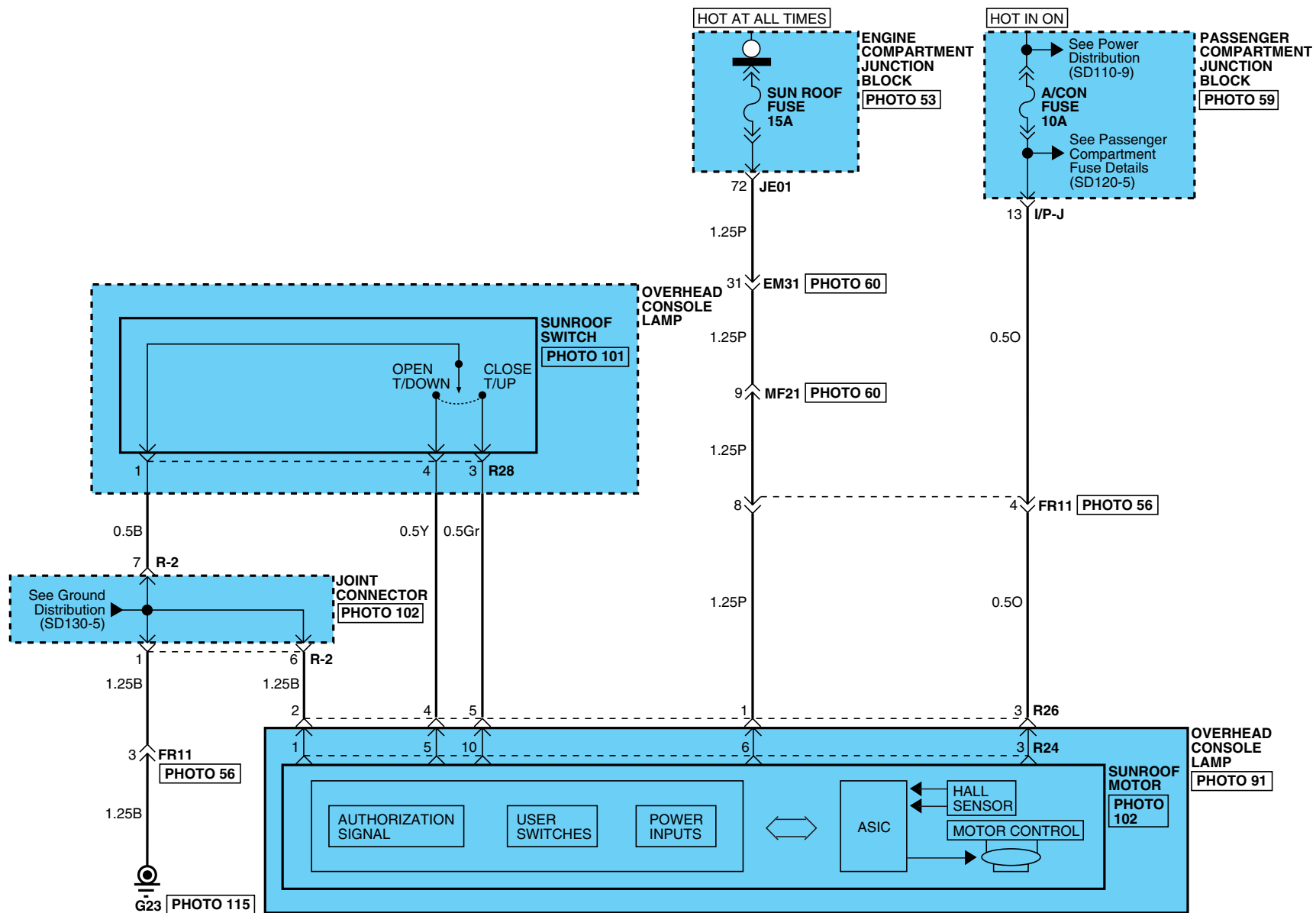

# SUNROOF

## SUNROOF (2)

SD816-2

R24

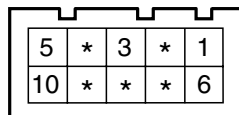

CR10F035

R26

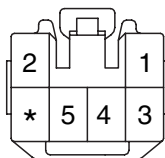

KET\_090III\_06F\_B

R28

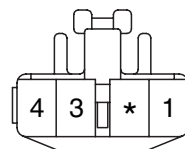

KET\_090III\_04F\_W

**BLANK**

POWER WINDOWS (1)

SD824-1

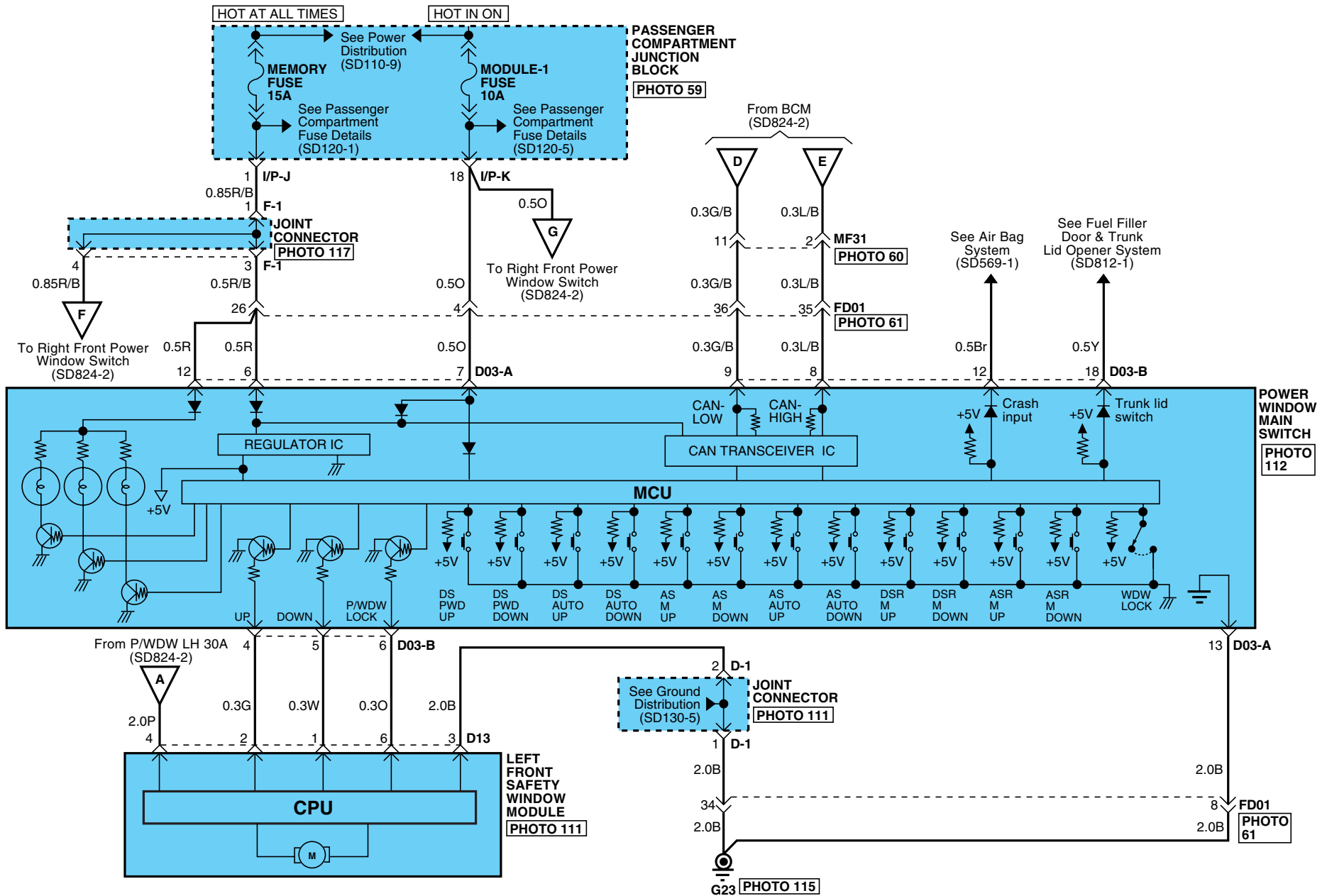

# POWER WINDOWS

## POWER WINDOWS (2)

SD824-2

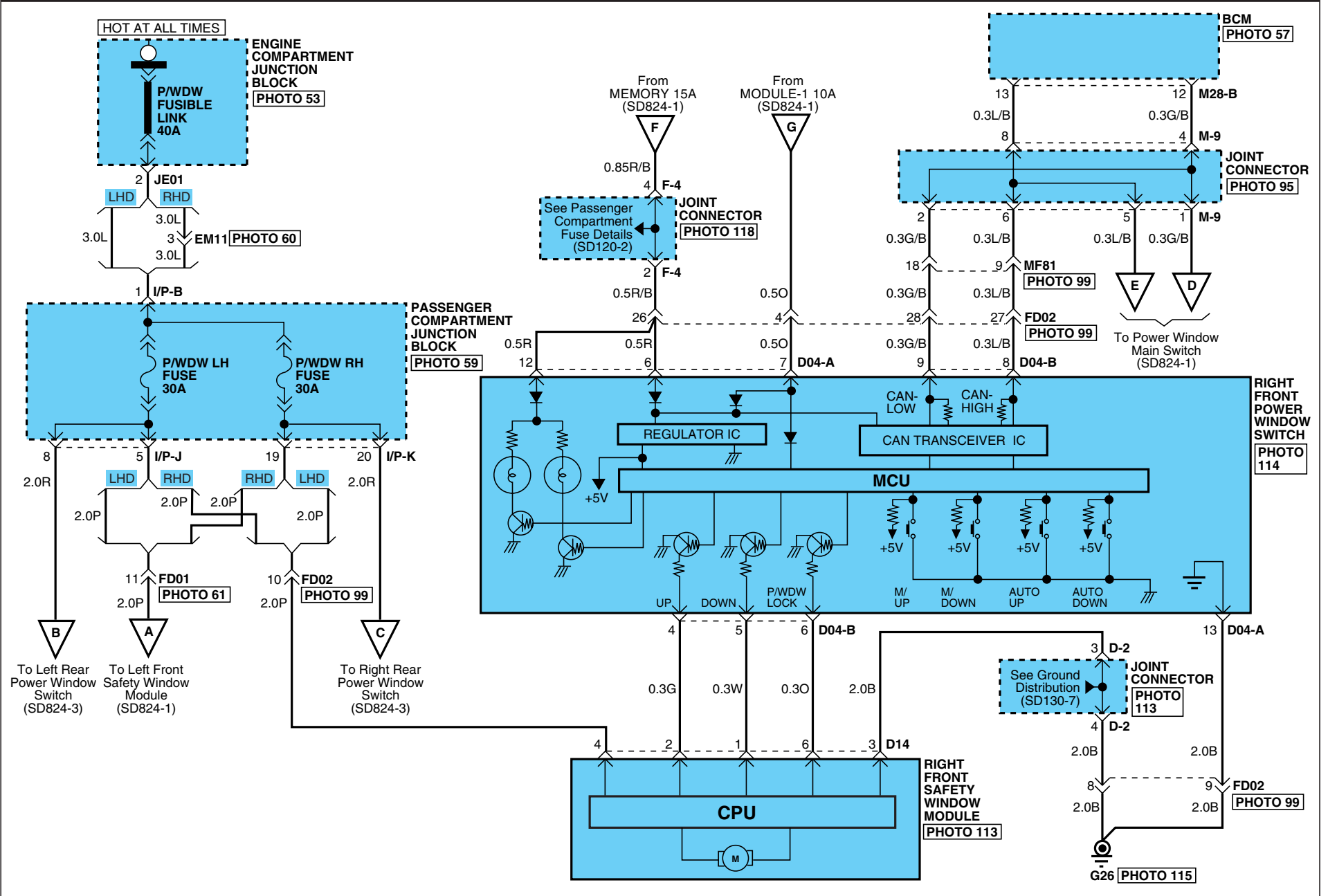

# POWER WINDOWS

## POWER WINDOWS (3)

SD824-3

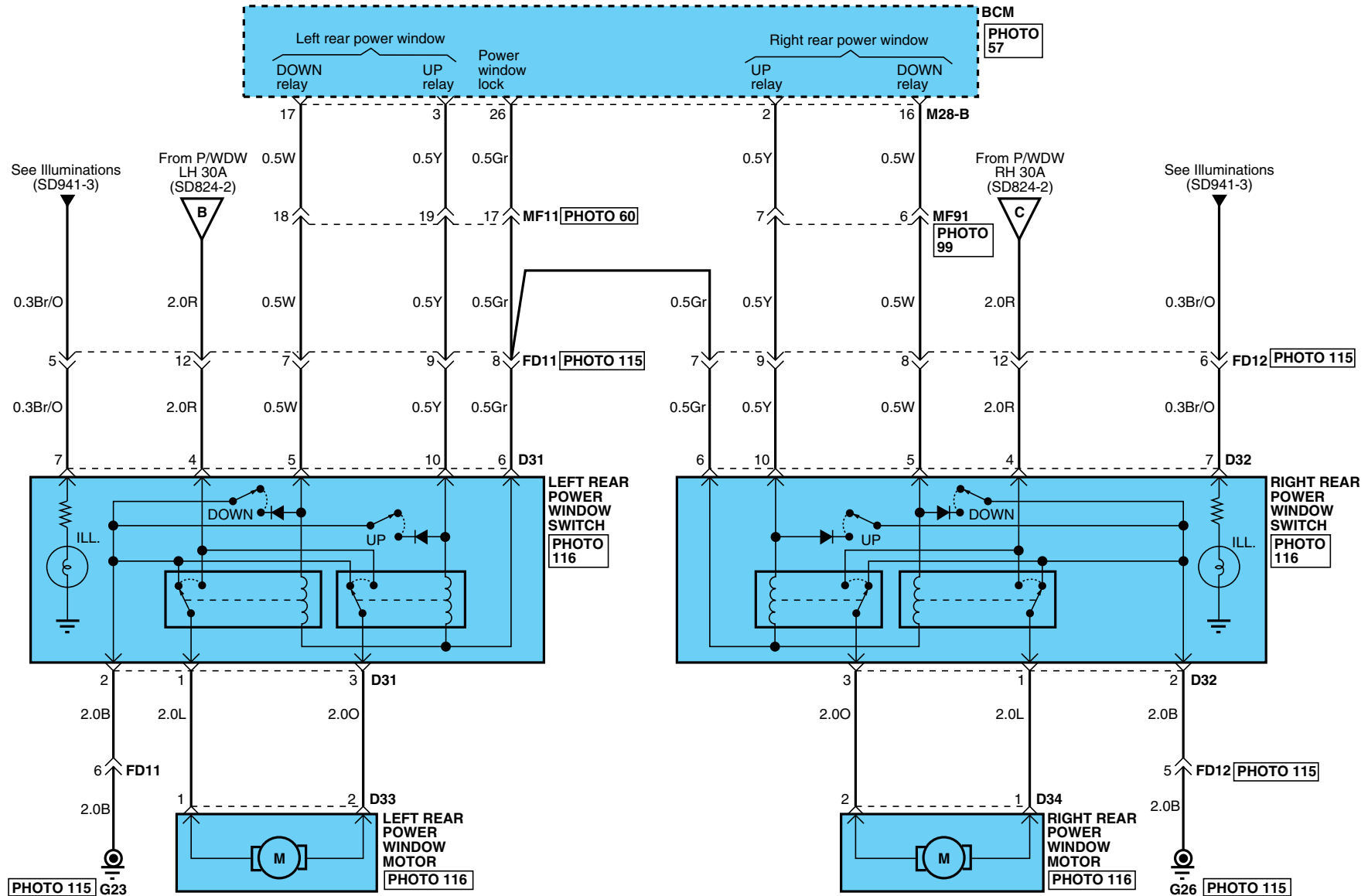



**POWER WINDOWS**

**POWER WINDOWS (4)**

**SD824-4**

**D03-A**

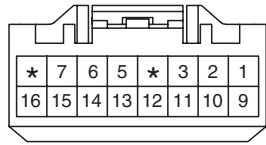

AMP\_090III\_16F\_W

**D03-B**

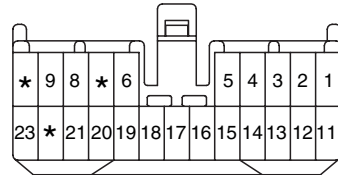

KET\_050\_23F\_W

**D04-A**

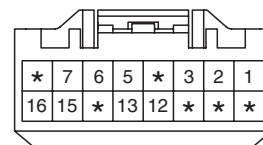

AMP\_090III\_16F\_W

**D04-B**

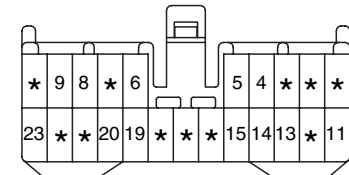

KET\_050\_23F\_W

**D13**

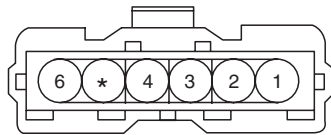

FCI\_SENSOR\_06F\_B

**D14**

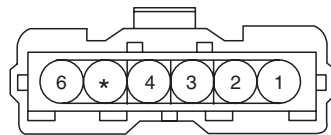

FCI\_SENSOR\_06F\_B

**D31**

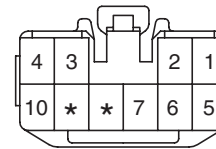

KET\_090III\_10F\_W

**D32**

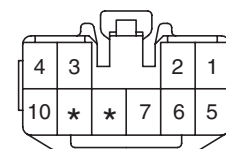

KET\_090III\_10F\_W

**D33**

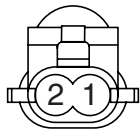

FCI\_SENSOR\_02F\_Gr

**D34**



FCI\_SENSOR\_02F\_Gr

**M28-B**

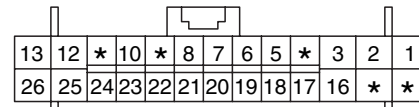

AMP\_0407\_26F\_W\_HD

**BLANK**

ELECTRO CHROME MIRROR (1)

SD851-1

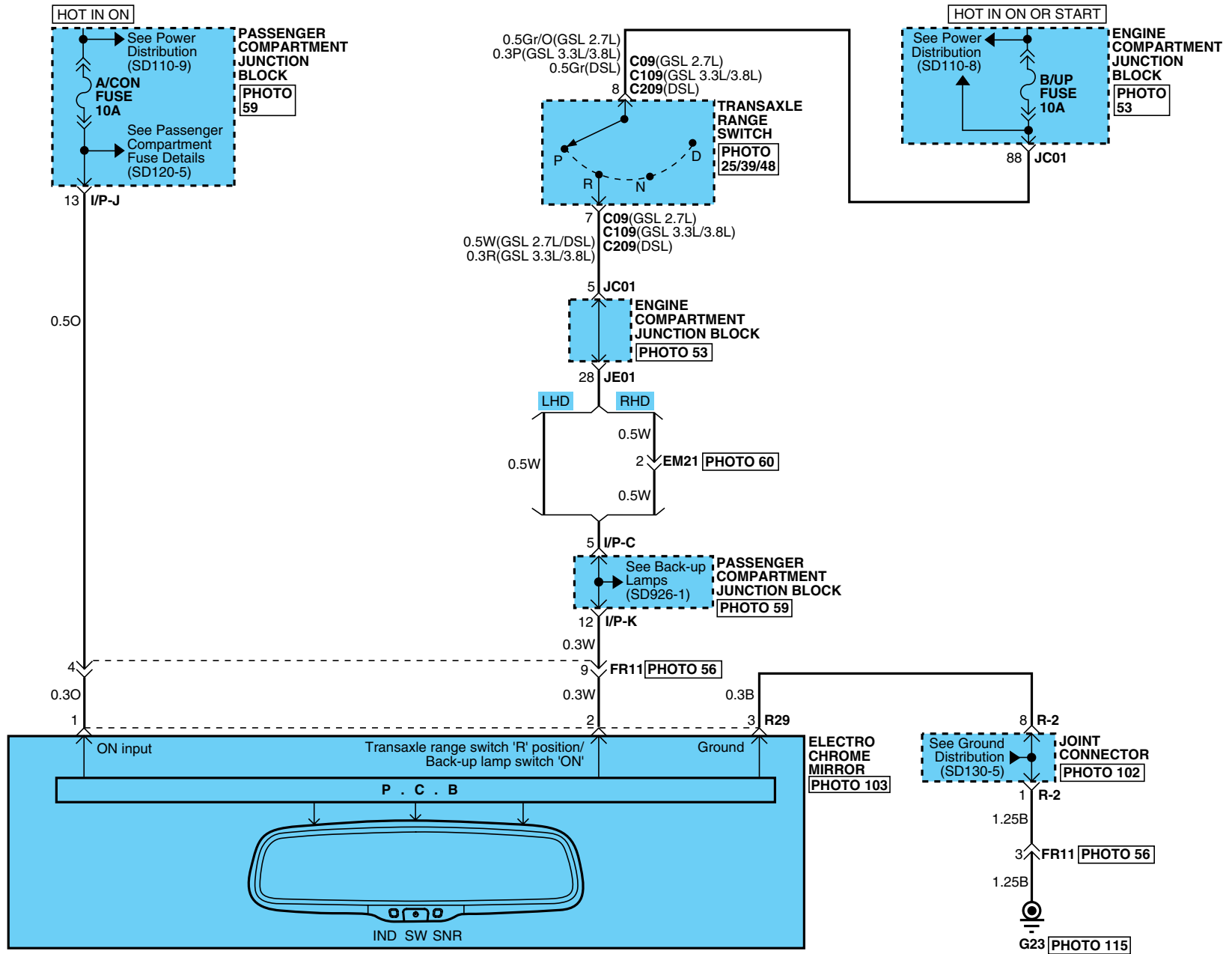

# ELECTRO CHROME MIRROR

## ELECTRO CHROME MIRROR (2)

SD851-2

C09/C109/C209



KET\_SSD\_10F\_B\_A

R29

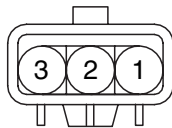

KET\_TLCWP\_03F\_W

BLANK

BLANK

REAR CURTAIN SYSTEM (1)

SD856-1

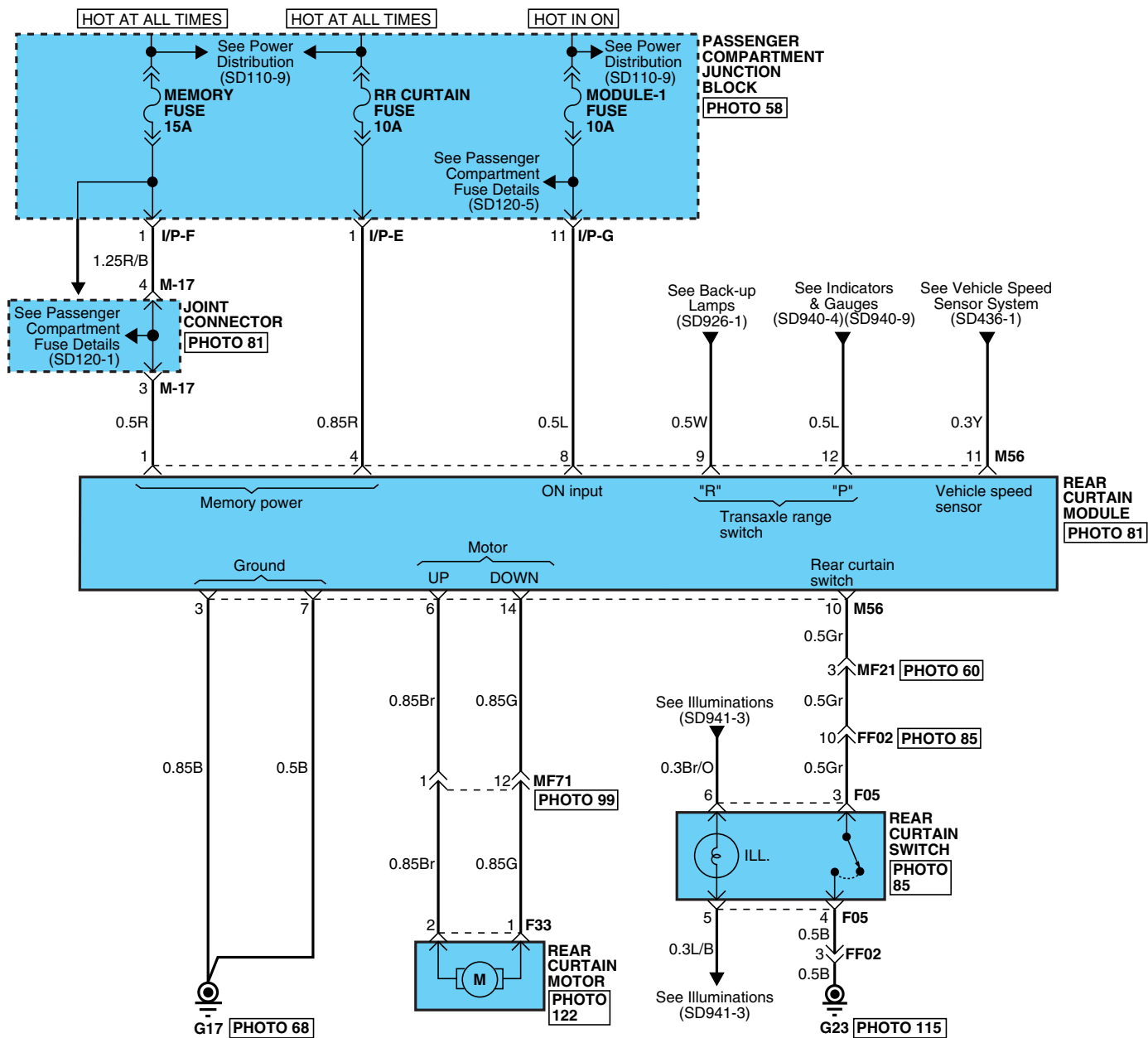

# REAR CURTAIN SYSTEM

## REAR CURTAIN SYSTEM (2)

SD856-2

F05

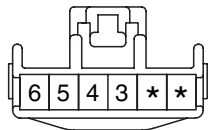

KET\_090II\_06F\_L\_SW

F33

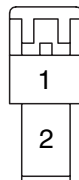

KUM\_DSD\_02F\_W

M56

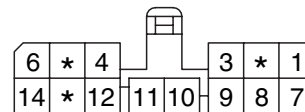

AMP\_070\_14F\_W

BLANK

POWER OUTSIDE MIRRORS (1)

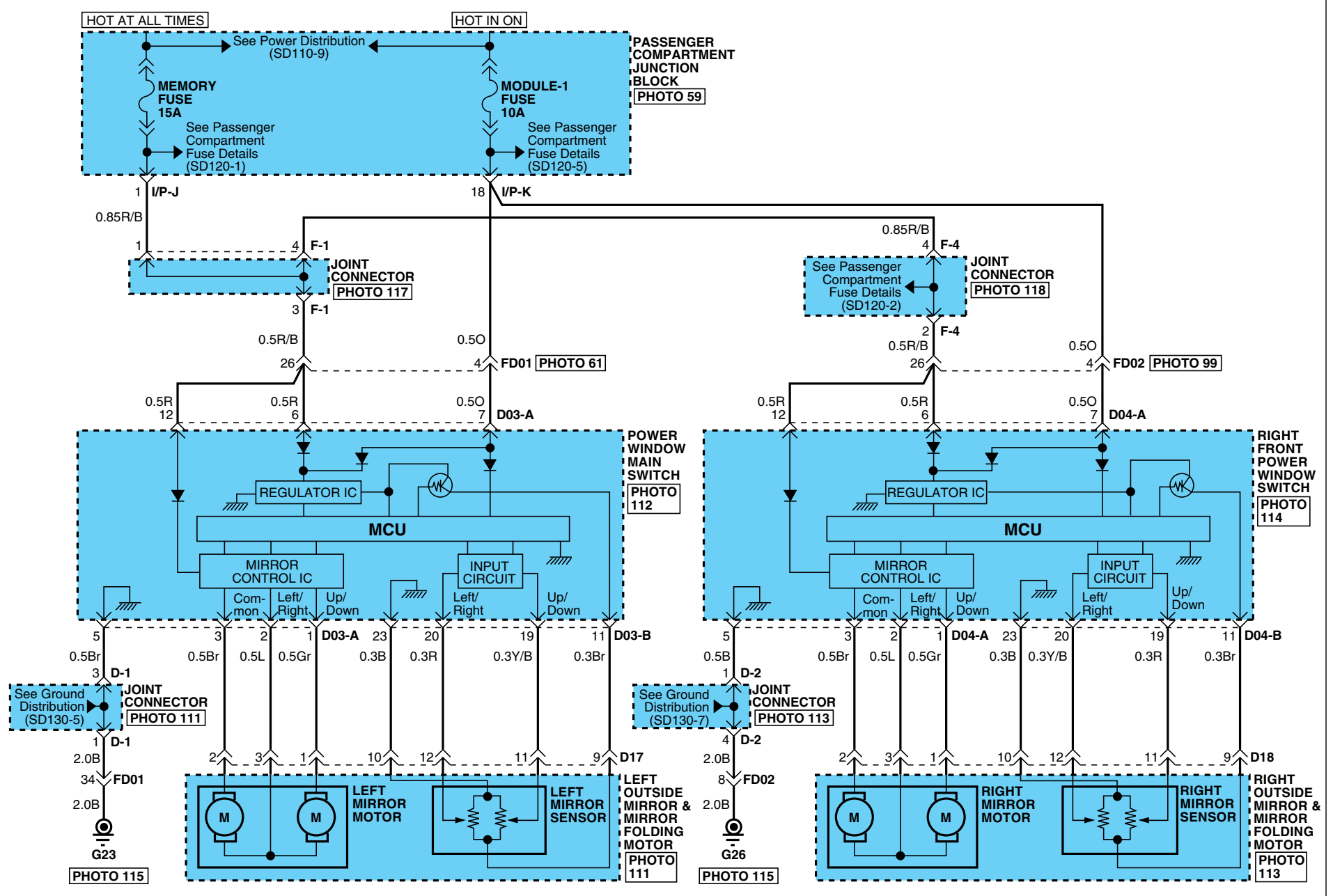

**POWER OUTSIDE MIRRORS**

**POWER OUTSIDE MIRRORS (2)**

**SD876-2**

**D03-A**

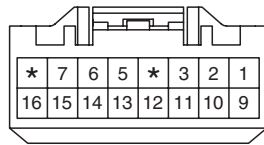

AMP\_090III\_16F\_W

**D03-B**

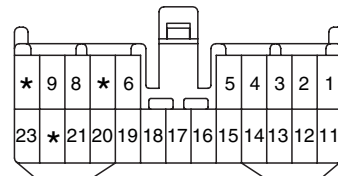

KET\_050\_23F\_W

**D04-A**

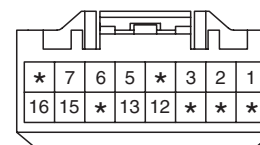

AMP\_090III\_16F\_W

**D04-B**

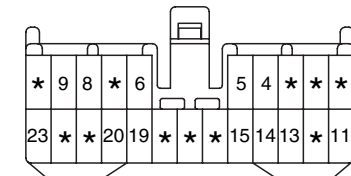

KET\_050\_23F\_W

**D17**

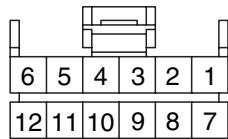

AMP\_040M1\_12F\_B

**D18**

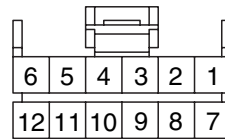

AMP\_040M1\_12F\_B

**BLANK**

**BLANK**

IMS (INTEGRATED MEMORY SYSTEM) (1)

SD877-1

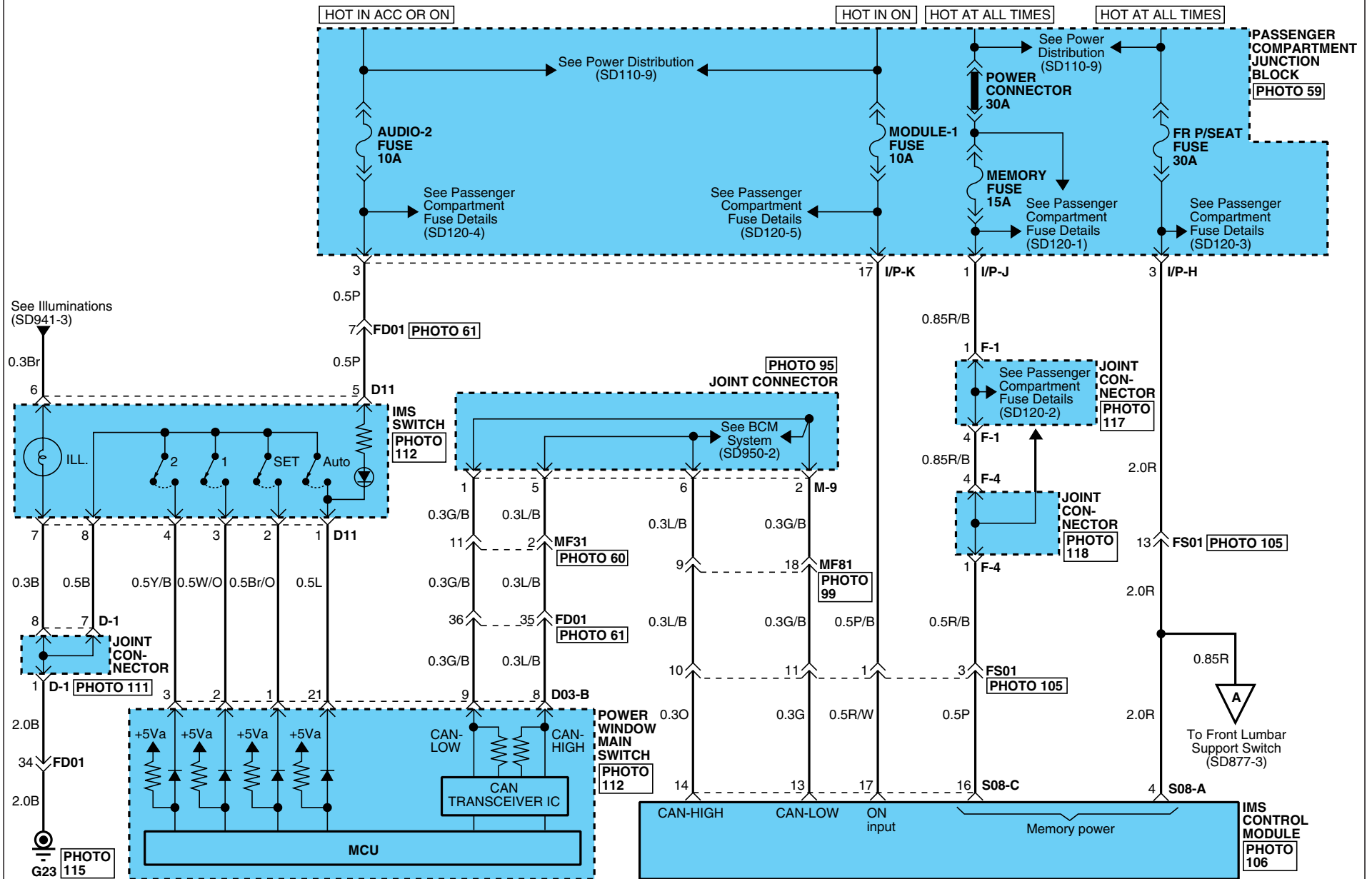



# IMS (INTEGRATED MEMORY SYSTEM)

## IMS (INTEGRATED MEMORY SYSTEM) (2)

SD877-2

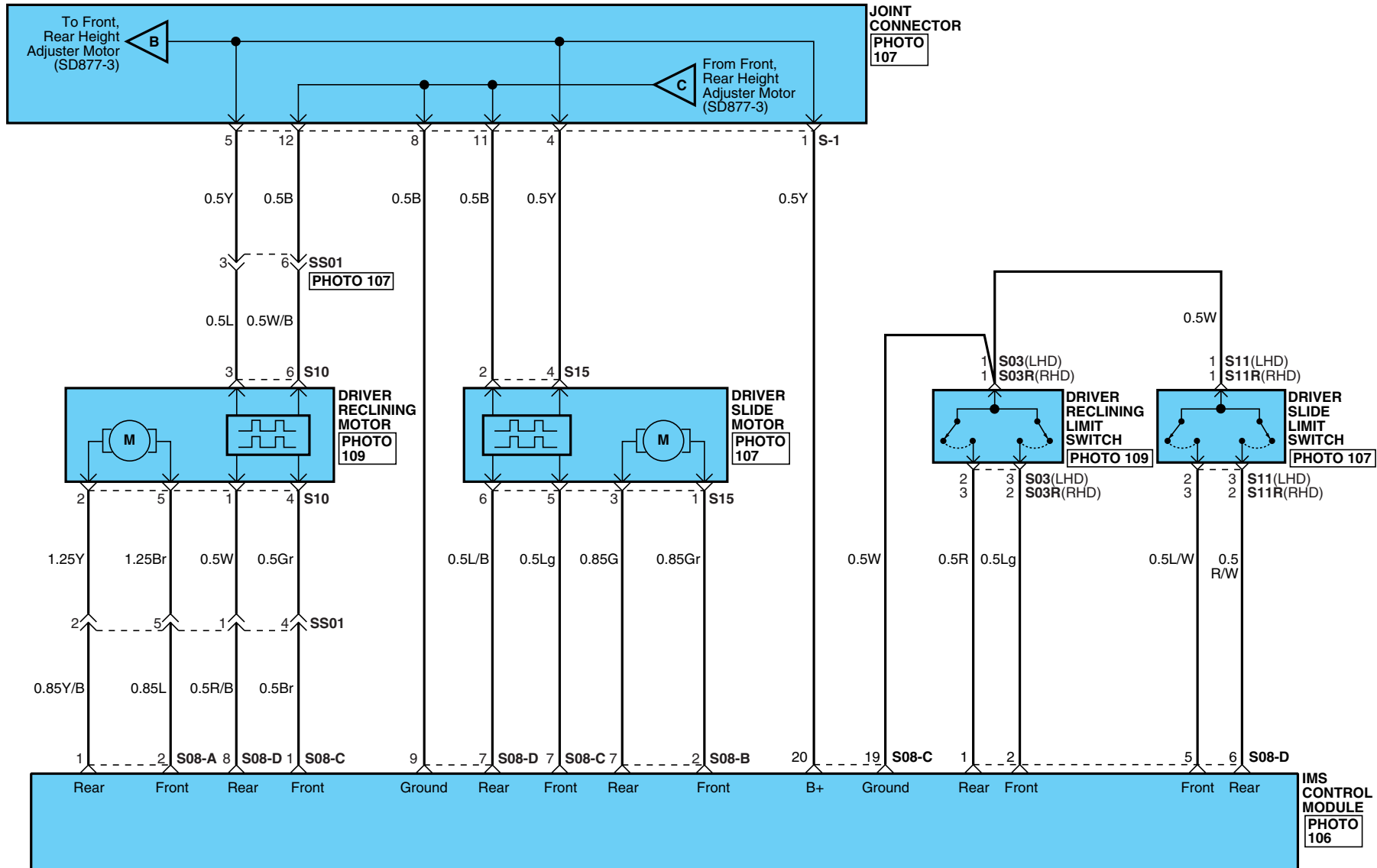





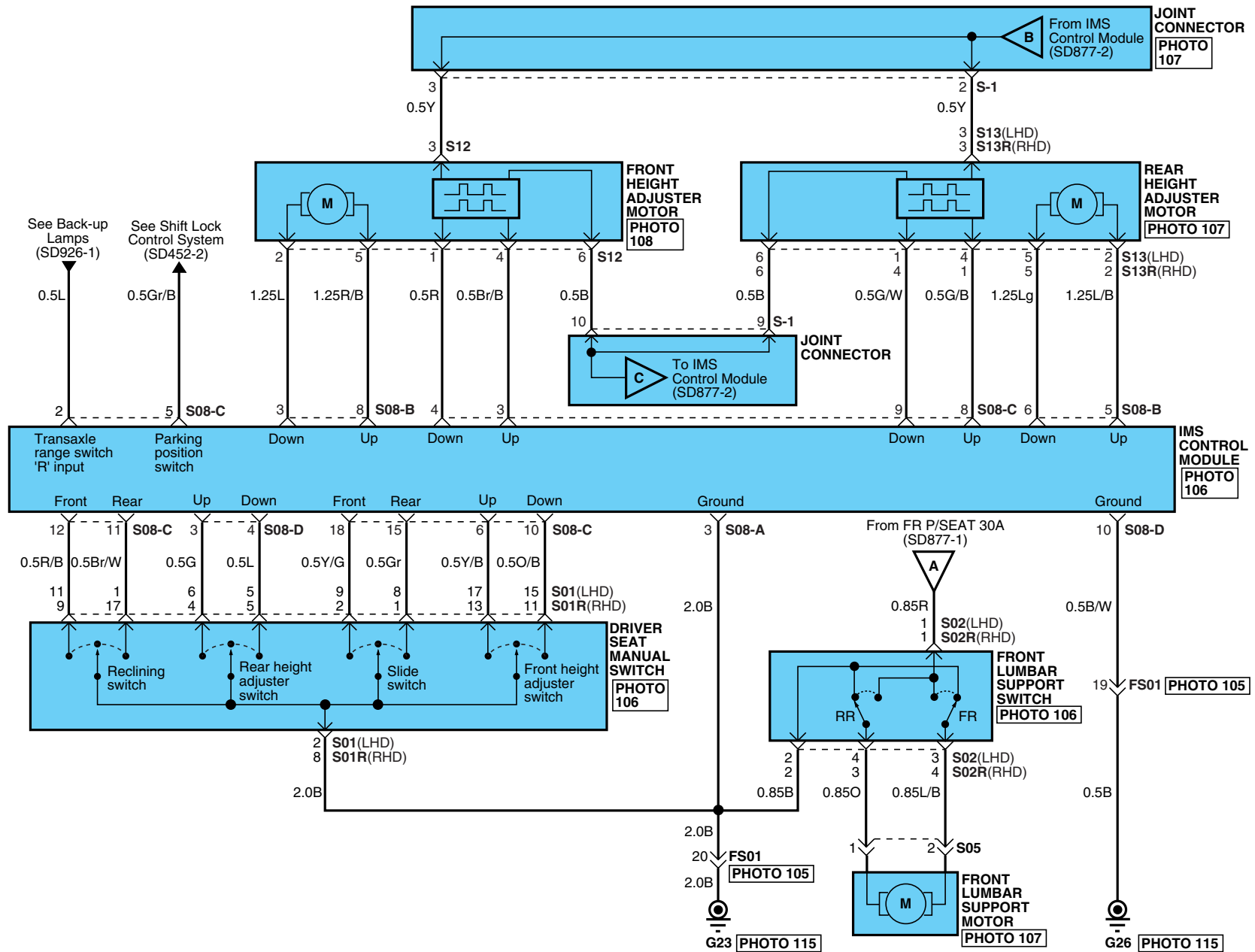

# IMS (INTEGRATED MEMORY SYSTEM)

## IMS (INTEGRATED MEMORY SYSTEM) (3)

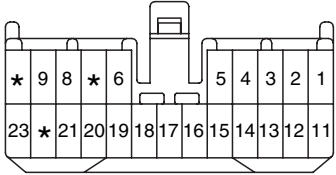
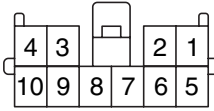
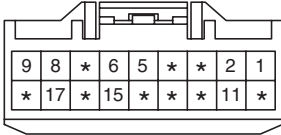
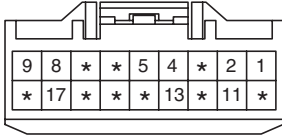
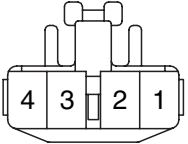
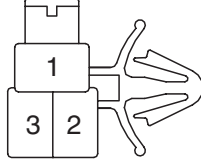
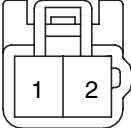
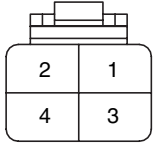
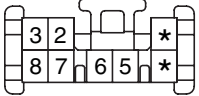
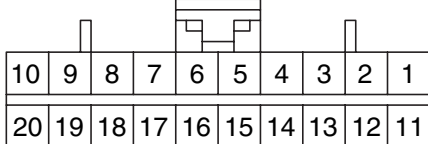
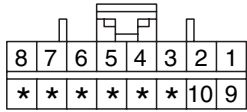
SD877-3

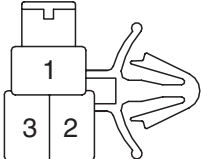

# IMS (INTEGRATED MEMORY SYSTEM)

IMS (INTEGRATED MEMORY SYSTEM) (4)			SD877-4
<p><b>D03-B</b></p>  <p>KET_050_23F_W</p>	<p><b>D11</b></p>  <p>KET_070_10F_W</p>	<p><b>S01</b></p>  <p>AMP_090II_18F_B</p>	<p><b>S01R</b></p>  <p>AMP_090II_18F_B</p>
<p><b>S02/S02R</b></p>  <p>KET_090II_04F</p>	<p><b>S03/S03R</b></p>  <p>KET_250_03F</p>	<p><b>S05</b></p>  <p>KET_090II_02M_L</p>	<p><b>S08-A</b></p>  <p>KET_250_04F</p>
<p><b>S08-B</b></p>  <p>KET_SDLII_08F</p>	<p><b>S08-C</b></p>  <p>AMP_040M2_20F</p>	<p><b>S08-D</b></p>  <p>AMP_040M2_16F</p>	<p><b>S10</b></p>  <p>KET_090IWP_06F</p>
<p><b>S11/S11R</b></p>  <p>KET_250_03F</p>	<p><b>S12</b></p>  <p>KET_090II_WP_06F</p>	<p><b>S13/S13R</b></p>  <p>KET_090II_WP_06F</p>	<p><b>S15</b></p>  <p>KET_090II_WP_06F</p>

POWER OUTSIDE MIRROR FOLDING SYSTEM (1)

SD878-1

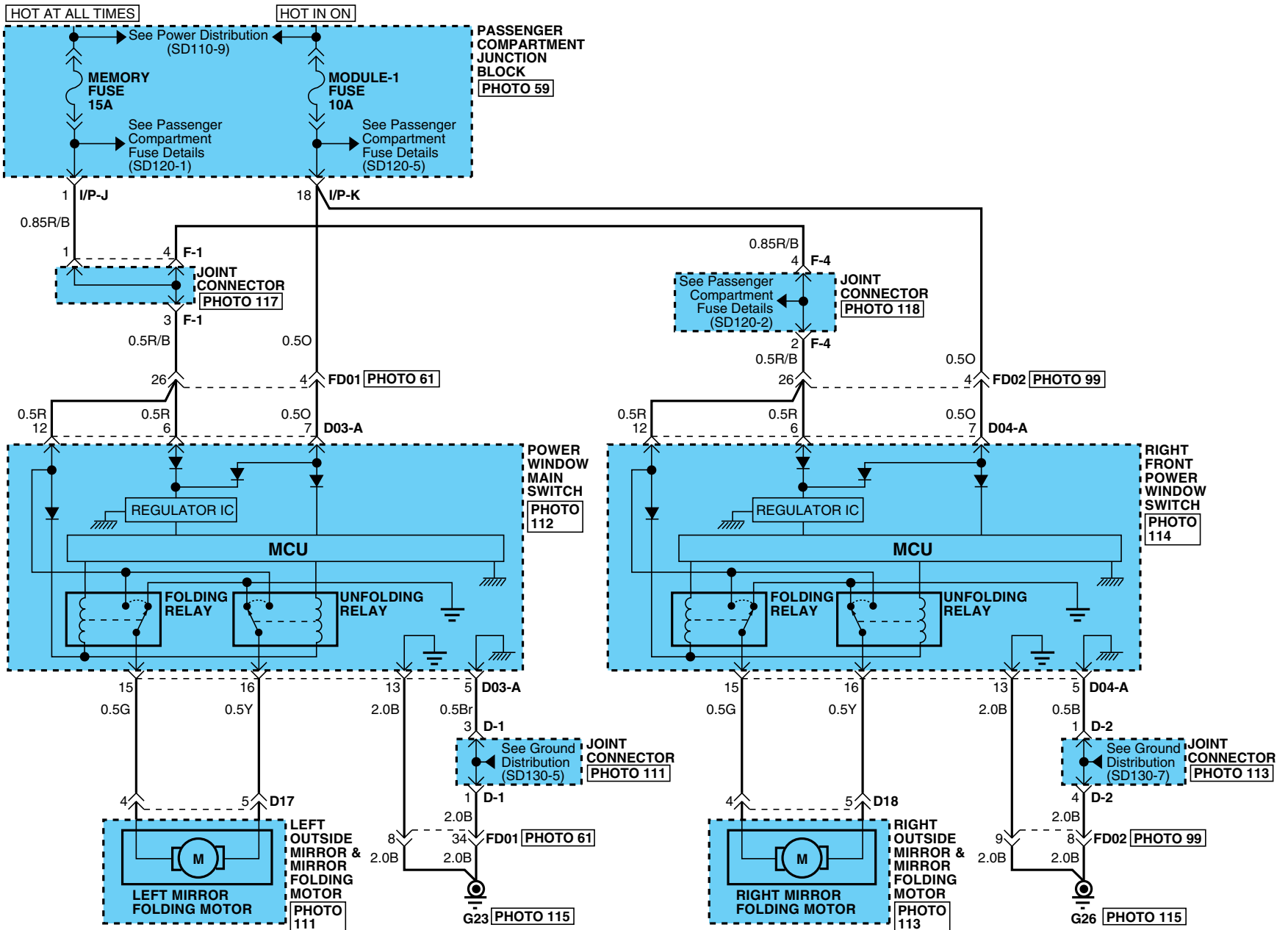

# POWER OUTSIDE MIRROR FOLDING SYSTEM

## POWER OUTSIDE MIRROR FOLDING SYSTEM (2)

SD878-2

D03-A

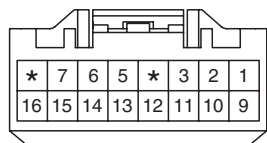

AMP\_090III\_16F\_W

D04-A

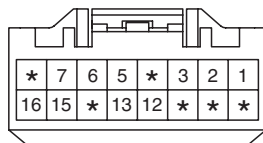

AMP\_090III\_16F\_W

D17

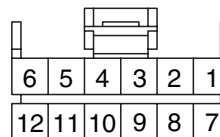

AMP\_040M1\_12F\_B

D18

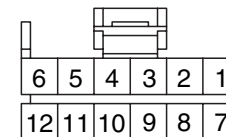

AMP\_040M1\_12F\_B

GLASS & OUTSIDE MIRROR DEFOGGER (1)

SD879-1

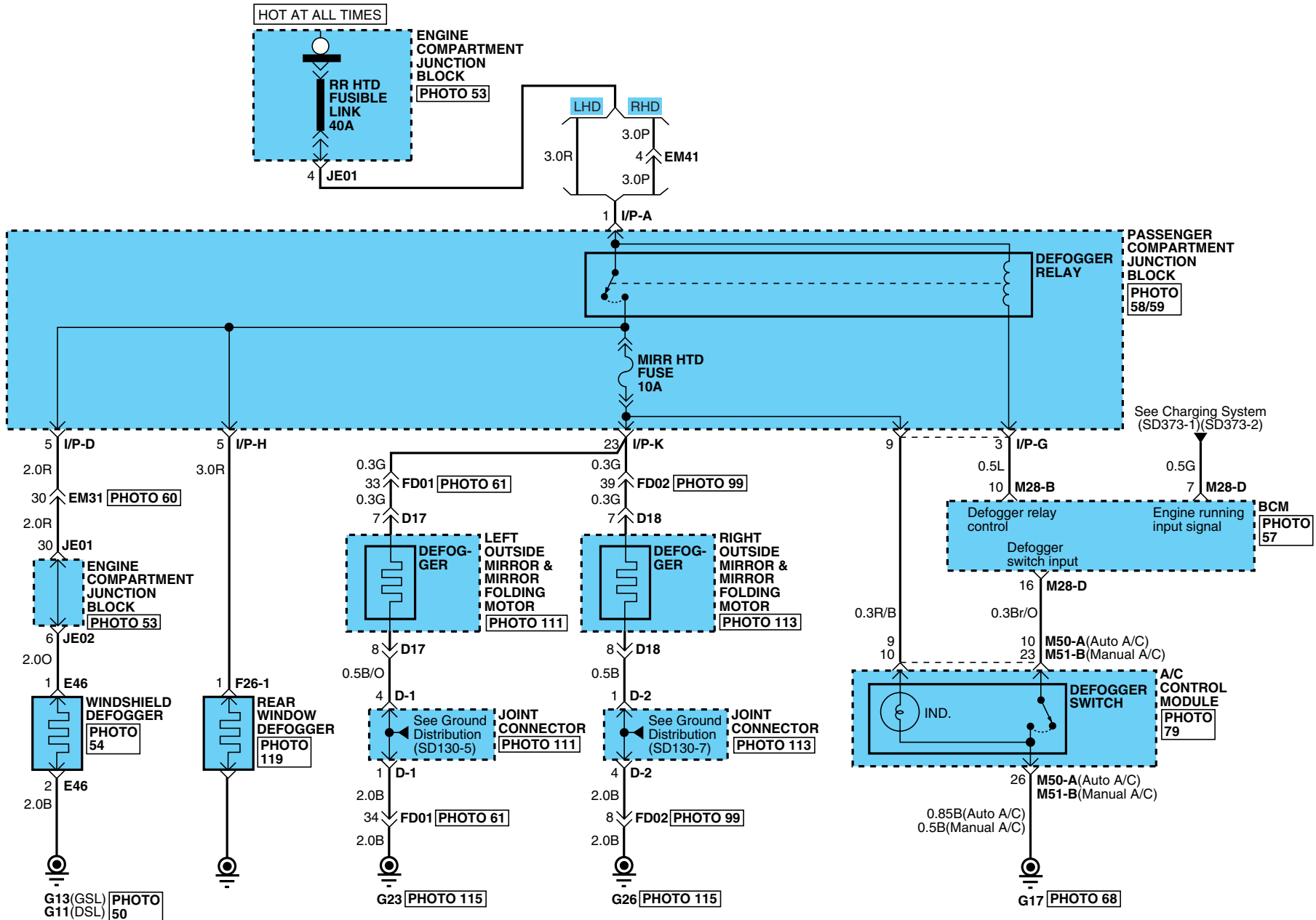

# GLASS & OUTSIDE MIRROR DEFOGGER

## GLASS & OUTSIDE MIRROR DEFOGGER (2)

SD879-2

**D17**

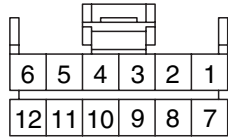

AMP\_040M1\_12F\_B

**D18**

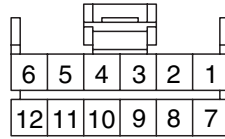

AMP\_040M1\_12F\_B

**E46**

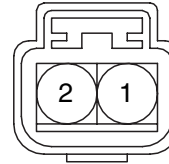

KUM\_NMWP\_02F\_B

**F26-1**

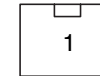

AMP\_PLM1\_01F\_B

**M28-B**

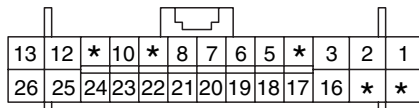

AMP\_0407\_26F\_W\_HD

**M28-D**

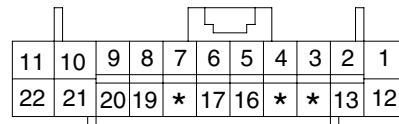

AMP\_0407\_22F\_W\_HD

**M50-A**

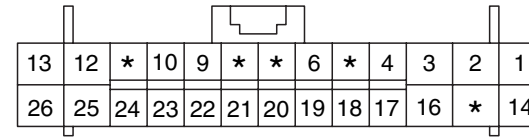

AMP\_0407\_26F\_W\_HD

**M51-B**

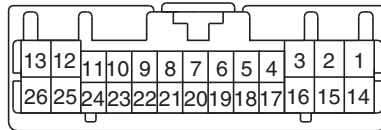

KET\_0407\_26F\_W

**BLANK**

**BLANK**

DRIVER POWER SEAT SYSTEM (W/O IMS) (1)

SD880-1

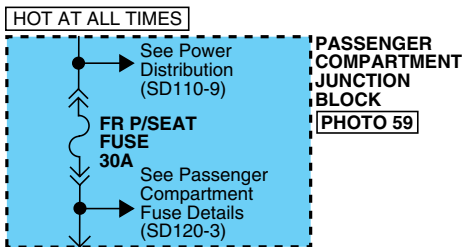

TABLE

	HEI ADJ. SW (FR)		SLIDE ADJ. SW				HEI ADJ. SW (RR)		REC ADJ. SW				REMARKS
	UP	DOWN	N		RH		UP	DOWN	N		RH		
			HEI	SLIDE	F	R			HEI	REC	F	R	
2	○	○			○	○	○	○					(+)
8			○	○	○	○							SEAT MTR
9					○	○							SEAT MTR
13													SEAT LIMIT
14			○	○									SEAT LIMIT
11									○	○	○	○	REC MTR
1									○	○	○	○	REC LIMIT
4									○	○	○	○	REC LIMIT
3									○	○	○	○	REC LIMIT
17	○		○										HEI (FR) MTR
15	○	○	○										HEI (FR) MTR
18	○		○										HEI (FR) LIMIT (-)
16		○	○										HEI (FR) LIMIT (-)
6								○	○	○			HEI (RR) MTR
5								○	○	○			HEI (RR) MTR
7								○	○	○			HEI (RR) LIMIT (-)
12								○	○	○			HEI (RR) LIMIT (-)

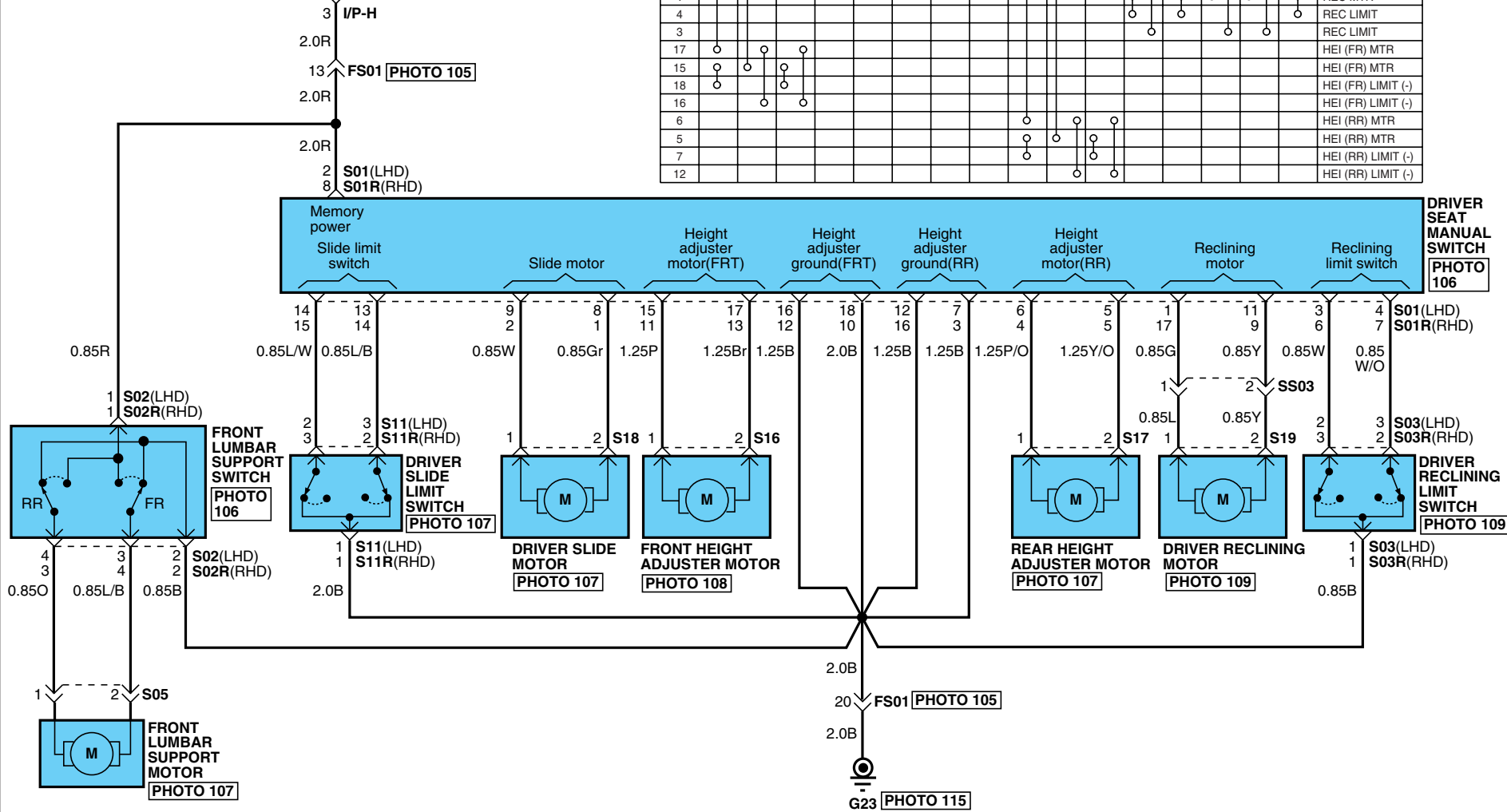



# DRIVER POWER SEAT SYSTEM

## DRIVER POWER SEAT SYSTEM (W/O IMS) (2)

SD880-2

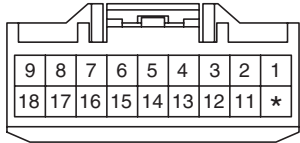
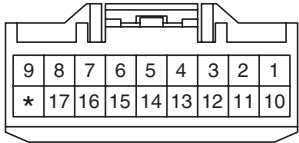
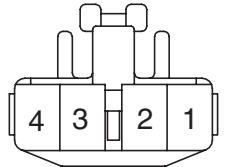
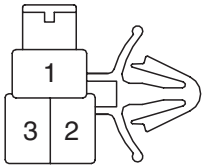
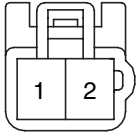
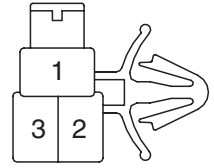
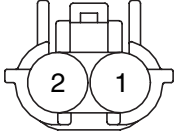
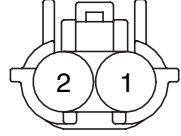
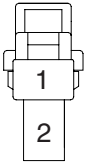
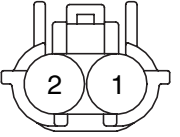
<p style="text-align: center;"><b>S01</b></p>  <p style="text-align: center;">AMP_090III_18F</p>	<p style="text-align: center;"><b>S01R</b></p>  <p style="text-align: center;">AMP_090III_18F</p>	<p style="text-align: center;"><b>S02/S02R</b></p>  <p style="text-align: center;">KET_090III_04F</p>	<p style="text-align: center;"><b>S03/S03R</b></p>  <p style="text-align: center;">KET_250_03F</p>
<p style="text-align: center;"><b>S05</b></p>  <p style="text-align: center;">KET_090II_02M_L</p>	<p style="text-align: center;"><b>S11/S11R</b></p>  <p style="text-align: center;">KET_250_03F</p>	<p style="text-align: center;"><b>S16</b></p>  <p style="text-align: center;">KUM_SWP_02F</p>	<p style="text-align: center;"><b>S17</b></p>  <p style="text-align: center;">KUM_SWP_02F</p>
<p style="text-align: center;"><b>S18</b></p>  <p style="text-align: center;">KET_250D/L_02F</p>	<p style="text-align: center;"><b>S19</b></p>  <p style="text-align: center;">KUM_SWP_02F</p>	<p style="text-align: center;"><b>BLANK</b></p>	<p style="text-align: center;"><b>BLANK</b></p>

PASSENGER POWER SEAT SYSTEM (1)

SD881-1

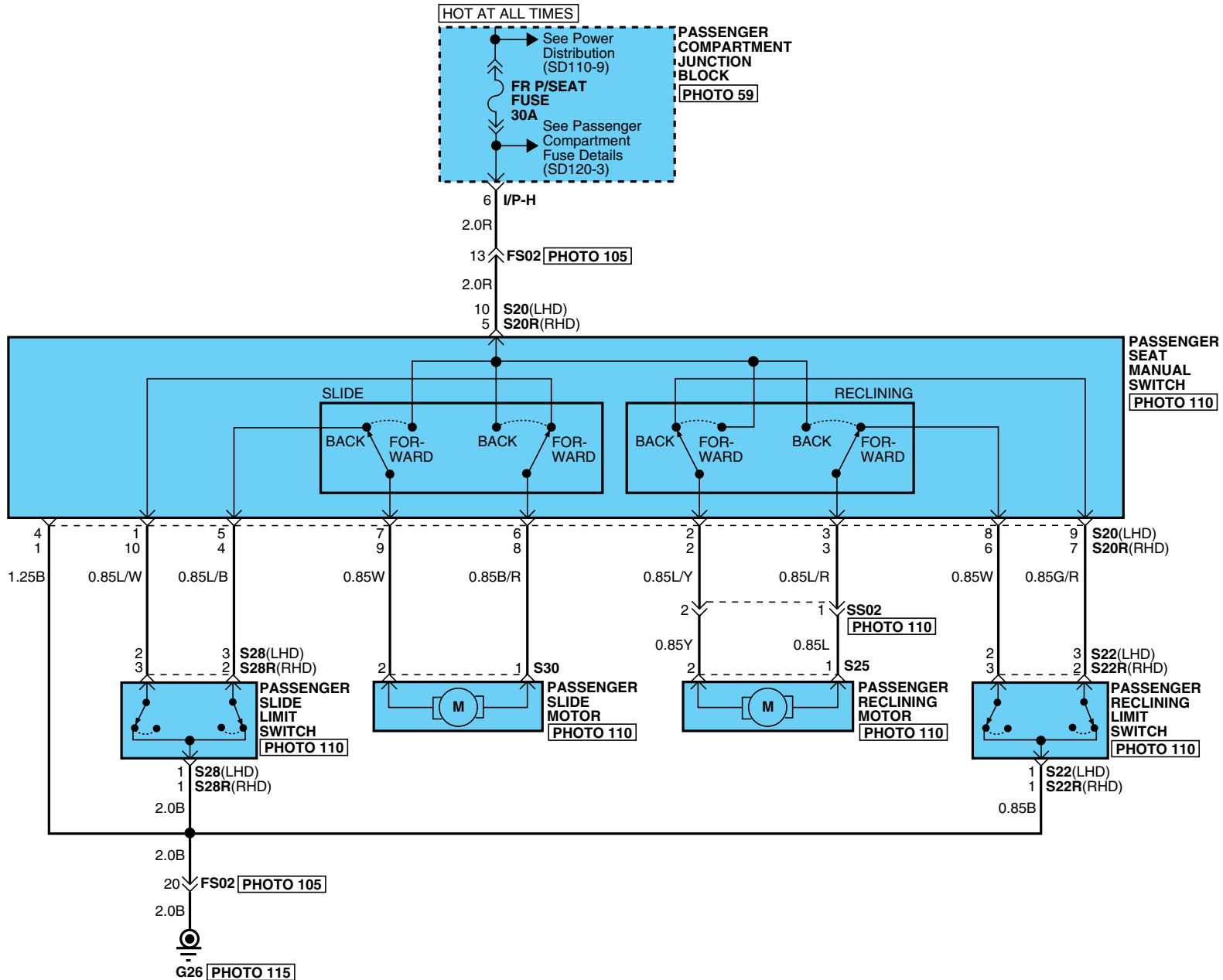

# PASSENGER POWER SEAT SYSTEM

## PASSENGER POWER SEAT SYSTEM (2)

SD881-2

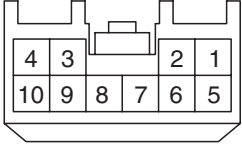
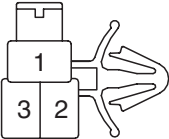
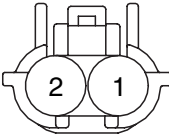
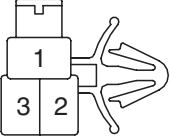
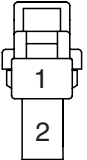
<p><b>S20/S20R</b></p>  <p>AMP_090III_10F</p>	<p><b>S22/S22R</b></p>  <p>KET_250_03F</p>	<p><b>S25</b></p>  <p>KET_SWP_02F</p>	<p><b>S28/S28R</b></p>  <p>KET_250_03F</p>
<p><b>S30</b></p>  <p>KET_250D/L_02F</p>	<p><b>BLANK</b></p>	<p><b>BLANK</b></p>	<p><b>BLANK</b></p>

# ADJUSTABLE SEAT WARMER SYSTEM

EFEFAA5F

## ADJUSTABLE SEAT WARMER SYSTEM (1)

SD885-1

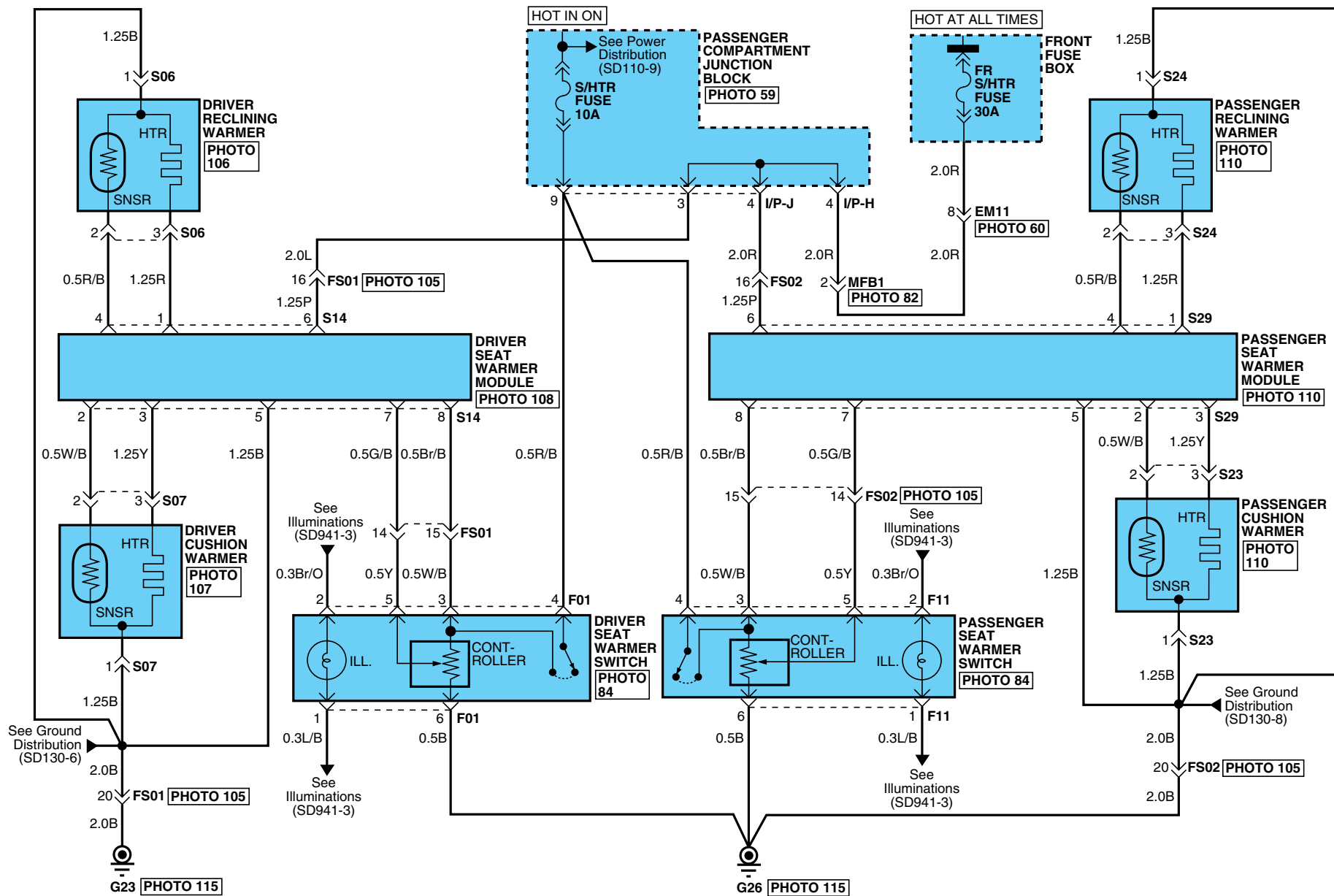

# ADJUSTABLE SEAT WARMER SYSTEM

## ADJUSTABLE SEAT WARMER SYSTEM (2)

SD885-2

**F01**

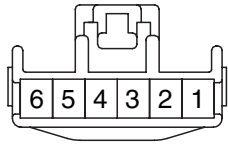

KET\_090II\_06F\_L\_SW

**F11**

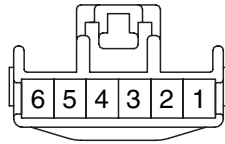

KET\_090II\_06F\_Y\_SW

**S06**

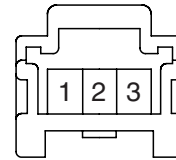

KET\_SDL\_03M\_B

**S07**

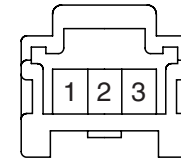

KET\_SDL\_03M

**S14**

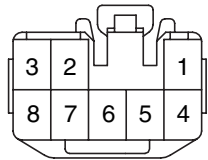

KET\_090II\_08F

**S23**

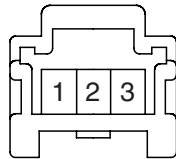

KET\_SDL\_03M

**S24**

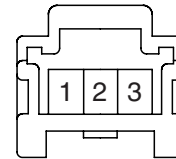

KET\_SDL\_03M\_B

**S29**

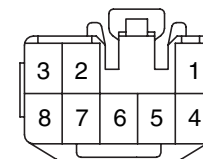

KET\_090II\_08F

HEAD LAMPS (1)

SD921-1

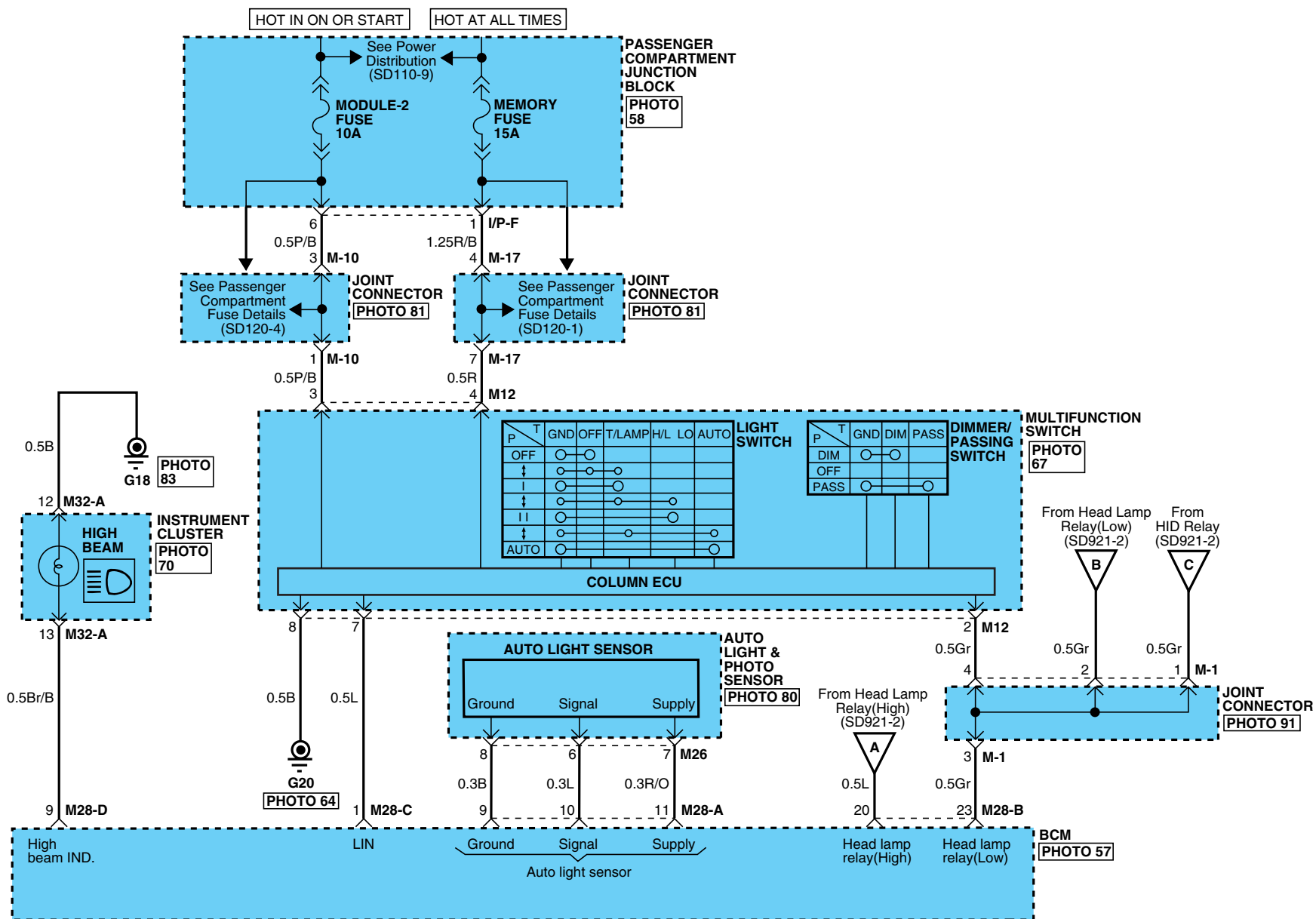

# HEAD LAMPS

## HEAD LAMPS (2)

SD921-2

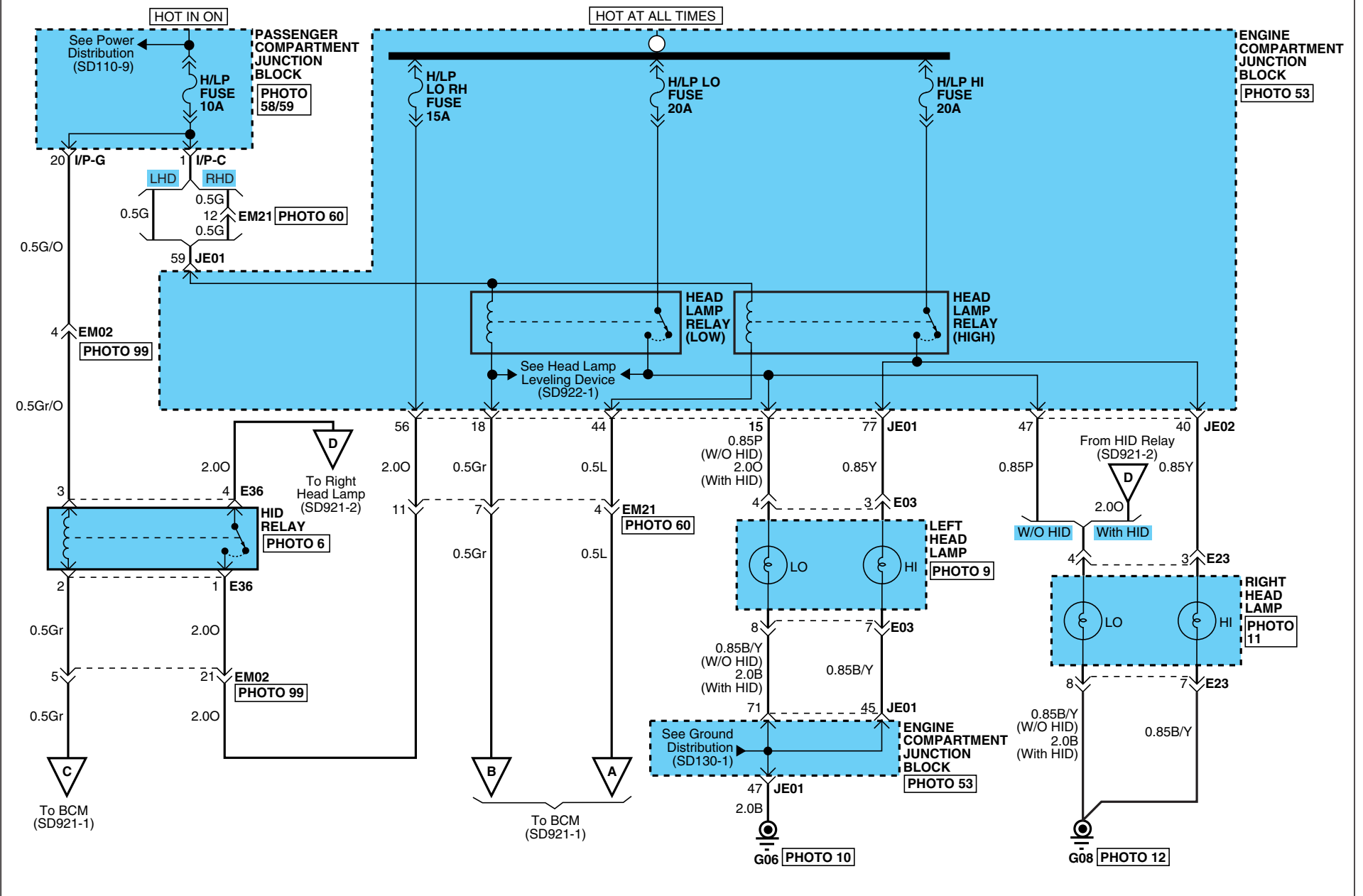

# HEAD LAMPS

## HEAD LAMPS (3)

SD921-3

**E03/E23**

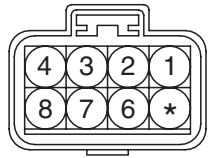

KUM\_NMWP\_08F\_B

**E36**

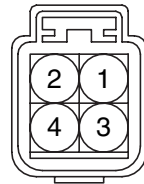

PKD\_280WP\_04F\_N

**BLANK**

**M12**

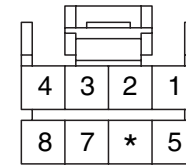

AMP\_040M1\_08F\_B

**M26**

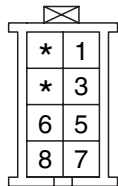

KET\_030\_08F\_GR

**M28-A**

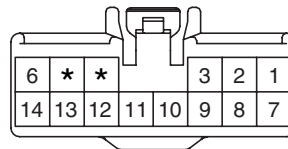

KET\_090III\_14F\_W

**M28-B**

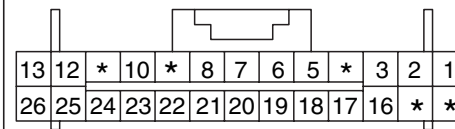

AMP\_0407\_26F\_W\_HD

**M28-C**

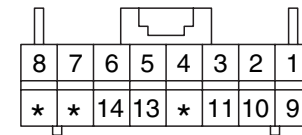

AMP\_0407\_16F\_W\_040

**M28-D**

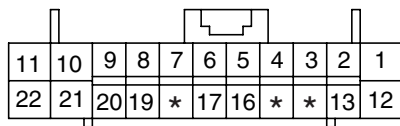

AMP\_0407\_22F\_W\_HD

**M32-A**

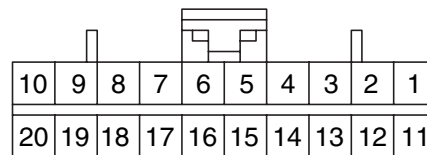

AMP\_040M2\_20F\_B

**BLANK**

**BLANK**



**HEAD LAMPS**

**HEAD LAMPS (4)**

**SD921-4**

**MEMO**

HEAD LAMP LEVELING DEVICE (1)

SD922-1

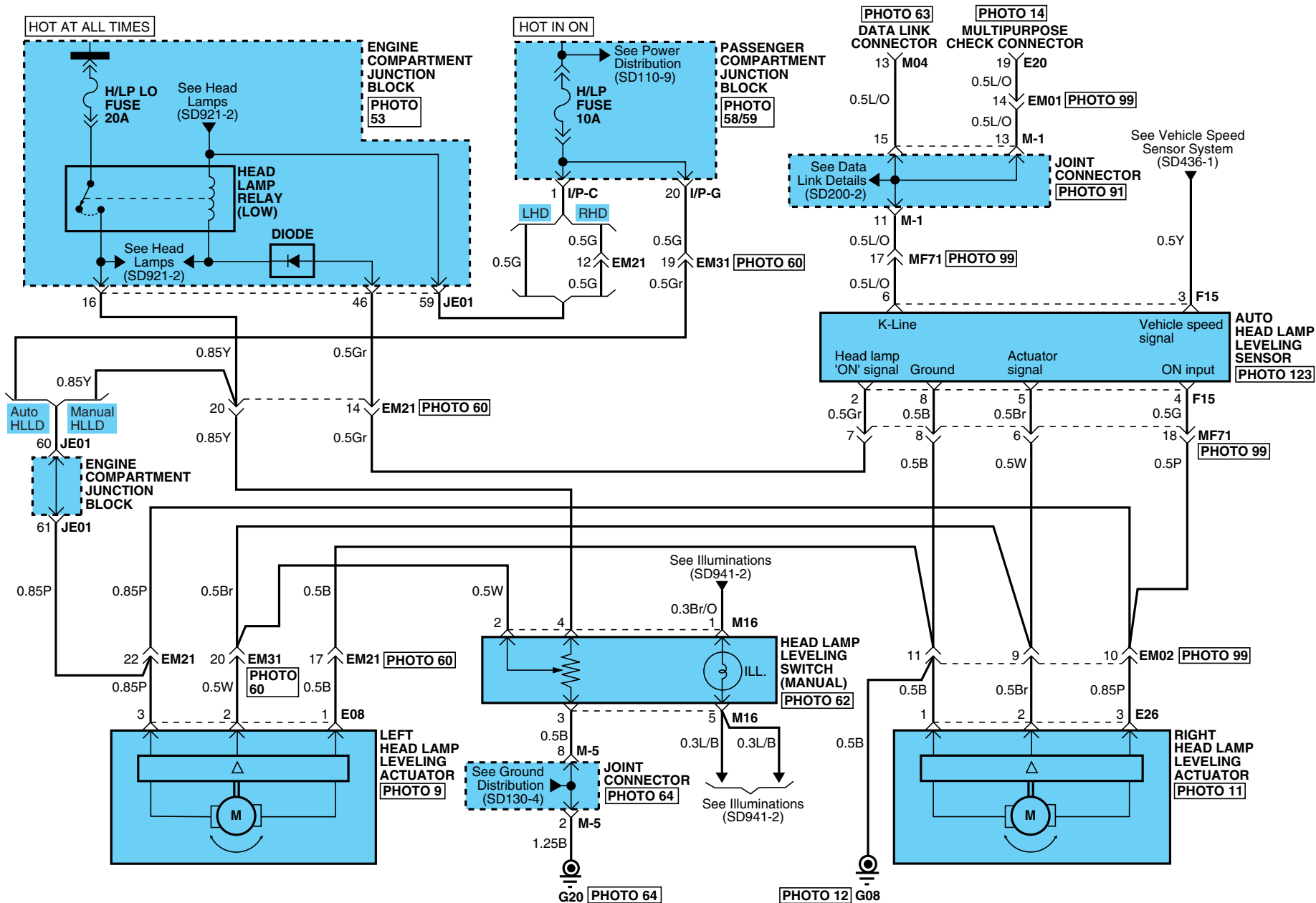

# HEAD LAMP LEVELING DEVICE

## HEAD LAMP LEVELING DEVICE (2)

SD922-2

**E08**

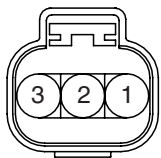

AMP\_025WP\_03F\_B

**E20**

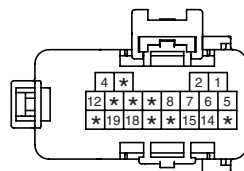

KET\_DIAG\_20F\_B\_BRK\_A

**E26**

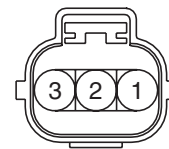

KUM\_NMWP\_03FS\_B

**F15**

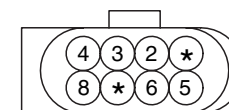

AMP\_DEV\_08F\_B

**M04**

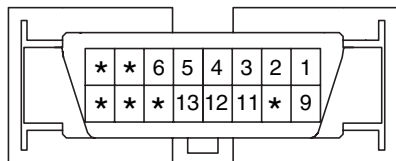

MLX\_OBDII\_16F\_B\_SIN

**M16**

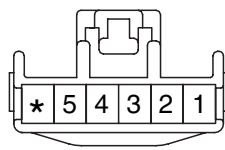

KET\_090II\_06F\_L\_SW

**BLANK**

**BLANK**

HEAD LAMP WASHER SYSTEM (1)

SD923-1

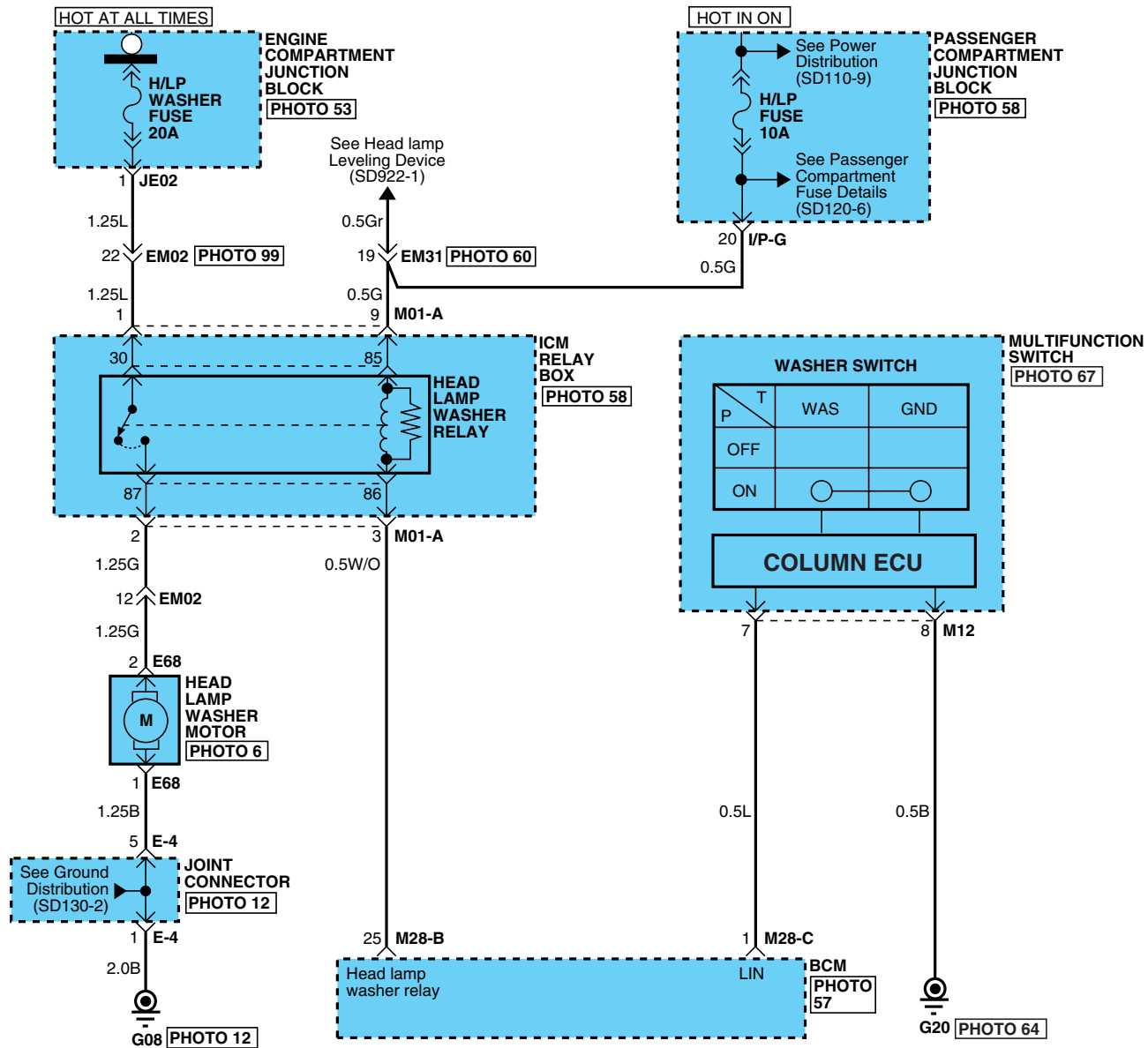

# HEAD LAMP WASHER SYSTEM

## HEAD LAMP WASHER SYSTEM (2)

SD923-2

**E68**

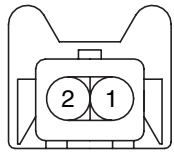

AMP\_JPT\_02F\_B\_CLIP

**M01-A**

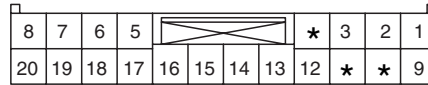

AMP\_0925\_20F\_W

**M12**

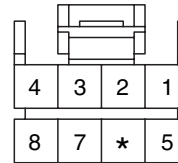

AMP\_040M1\_08F\_B

**M28-B**

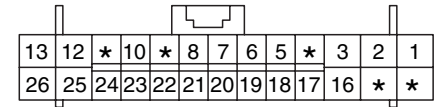

AMP\_0407\_26F\_W\_HD

**M28-C**

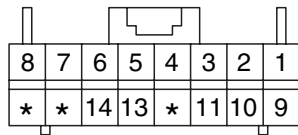

AMP\_0407\_16F\_W\_040

**BLANK**

**BLANK**

**BLANK**

FRONT FOG & REAR FOG LAMPS (1)

SD924-1

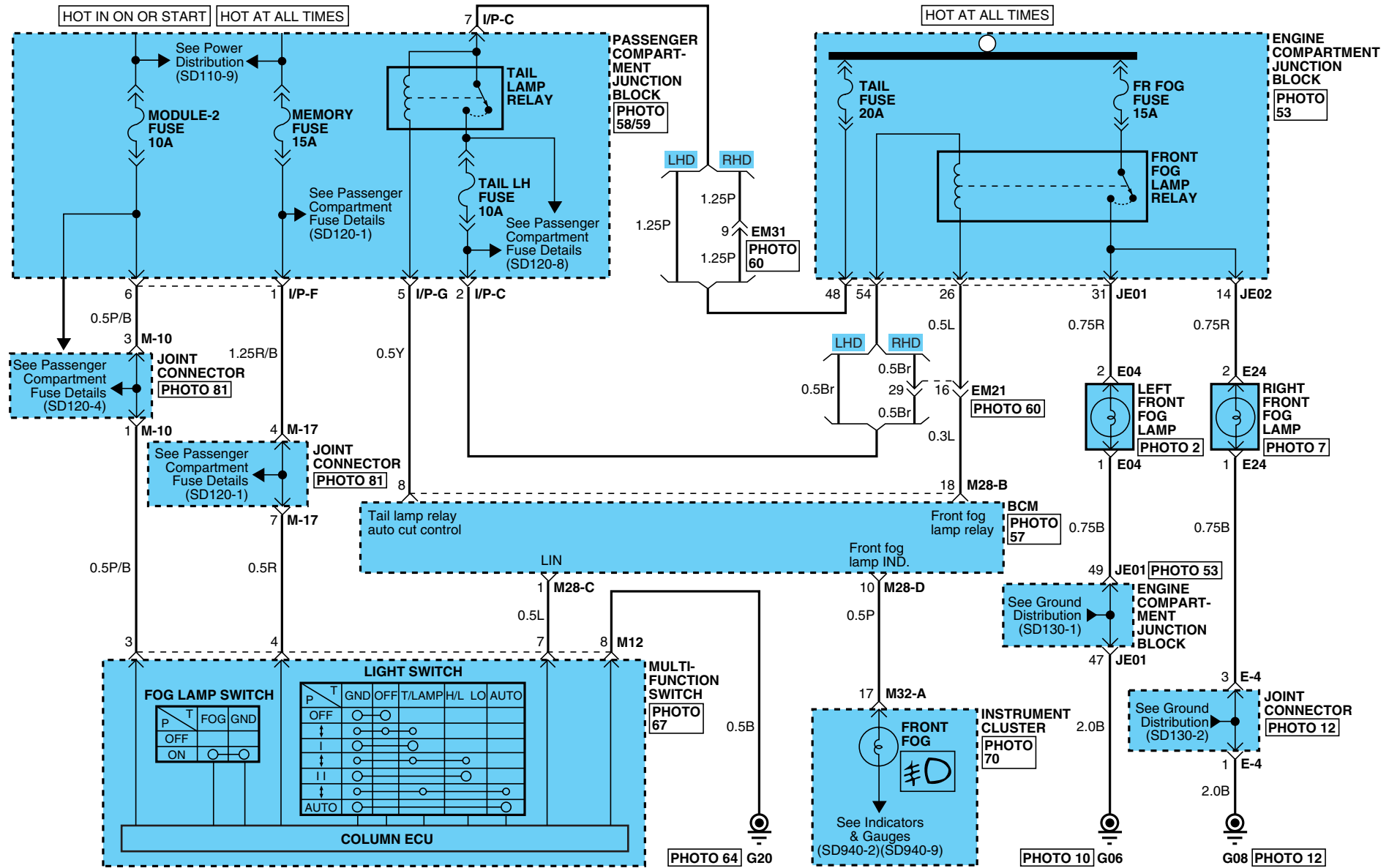

# FRONT FOG & REAR FOG LAMPS

## FRONT FOG & REAR FOG LAMPS (2)

SD924-2

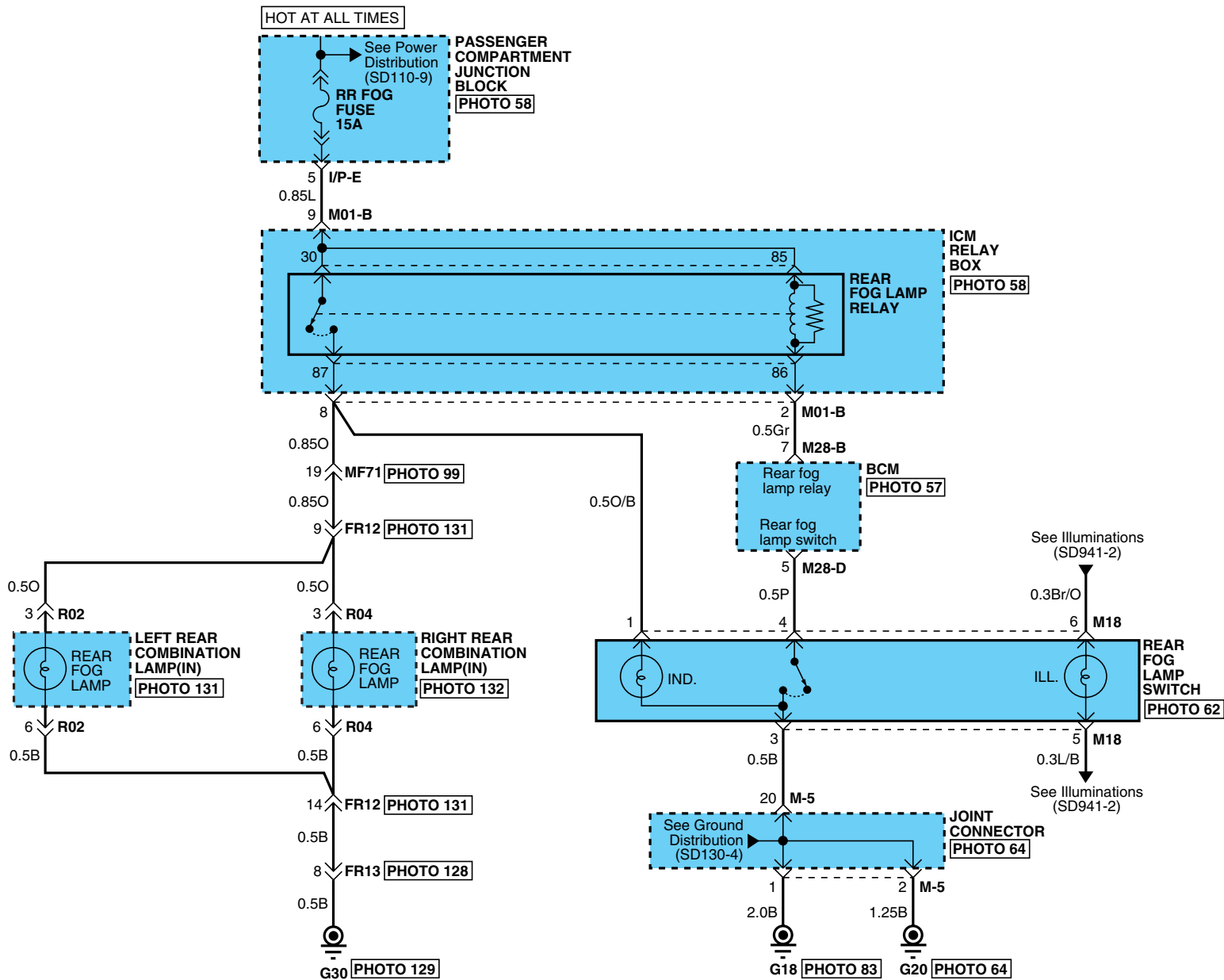

# FRONT FOG & REAR FOG LAMPS

## FRONT FOG & REAR FOG LAMPS (3)

SD924-3

**E04**



KET\_110WP\_02F\_B\_FOG

**E24**



KET\_110WP\_02F\_B\_FOG

**M01-B**

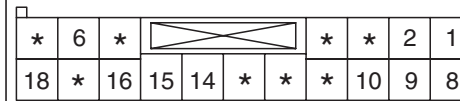

AMP\_0925\_18F\_W

**M12**

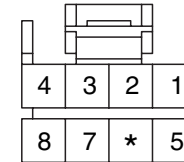

AMP\_040M1\_08F\_B

**M18**

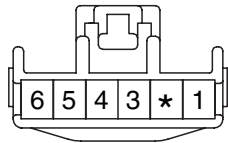

KET\_090II\_06F\_Y\_SW

**M28-B**

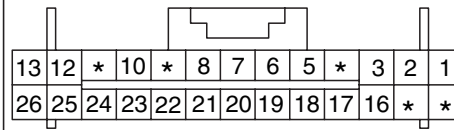

AMP\_0407\_26F\_W\_HD

**M28-C**

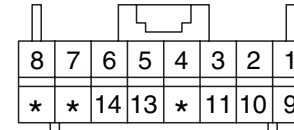

AMP\_0407\_16F\_W\_040

**M28-D**

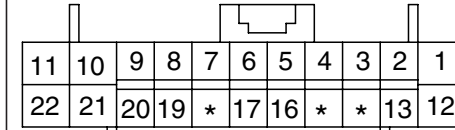

AMP\_0407\_22F\_W\_HD

**M32-A**

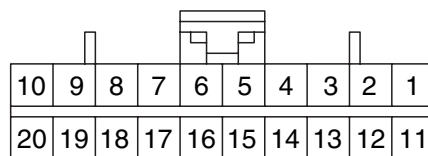

AMP\_040M2\_20F\_B

**R02/R04**

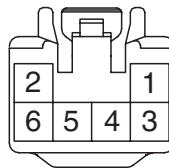

KET\_090III\_06F\_W

**BLANK**

**BLANK**



**FRONT FOG & REAR FOG LAMPS**

**FRONT FOG & REAR FOG LAMPS (4)**

**SD924-4**

**MEMO**

TURN & HAZARD LAMPS (1)

SD925-1

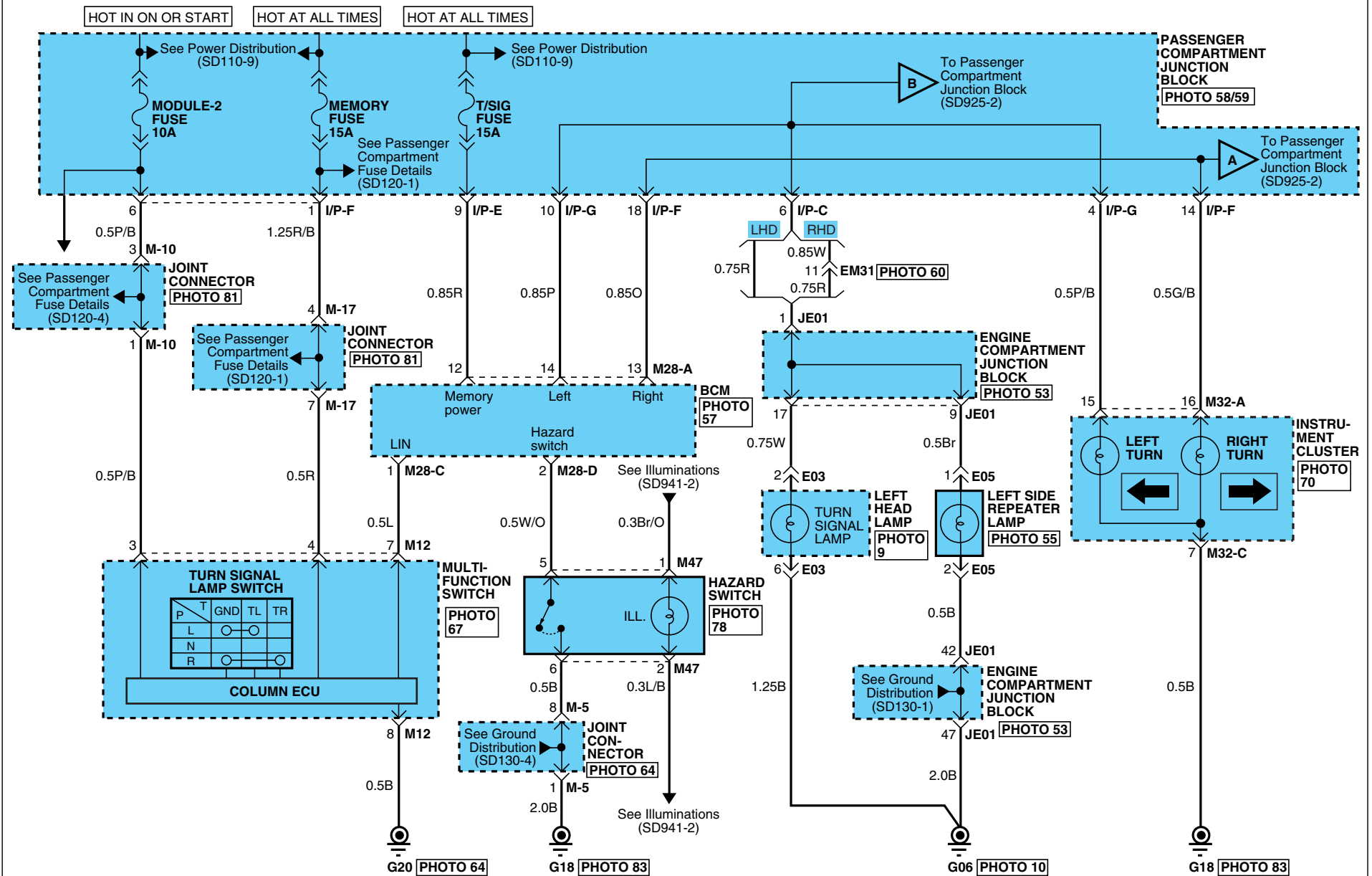

# TURN & HAZARD LAMPS

## TURN & HAZARD LAMPS (2)

SD925-2

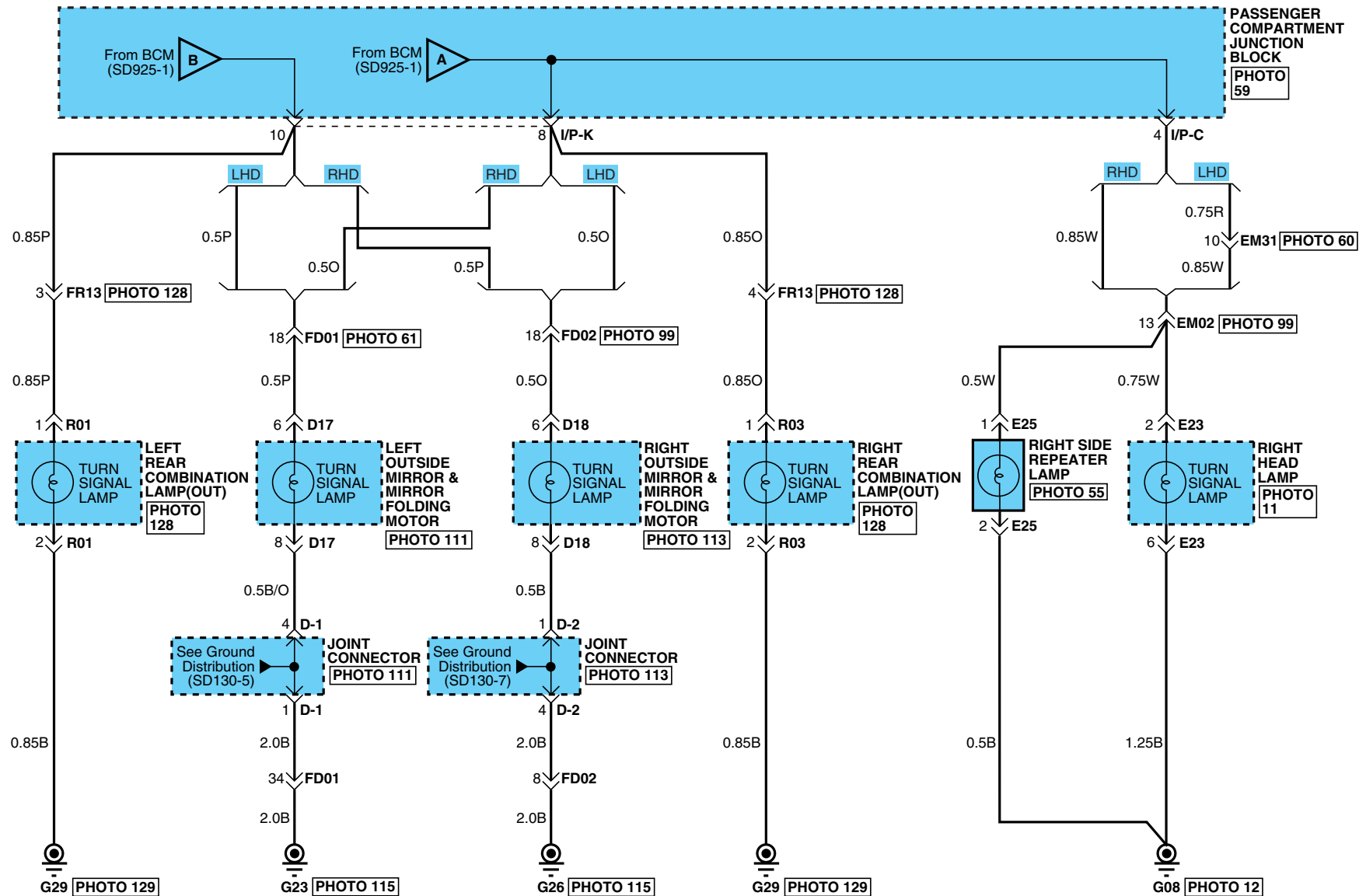

# TURN & HAZARD LAMPS

## TURN & HAZARD LAMPS (3)

SD925-3

**D17**

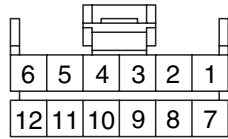

AMP\_040M1\_12F\_B

**D18**

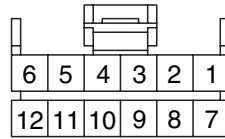

AMP\_040M1\_12F\_B

**E03**

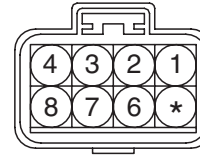

KUM\_NMWP\_08F\_B

**E05**

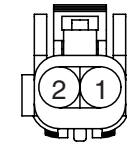

KUM\_62Z\_02F\_GR

**E23**

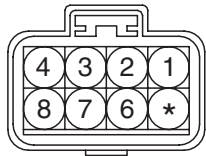

KUM\_NMWP\_08F\_B

**E25**

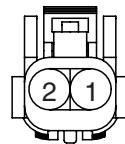

KUM\_62Z\_02F\_GR

**M12**

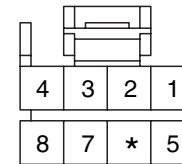

AMP\_040M1\_08F\_B

**M28-A**

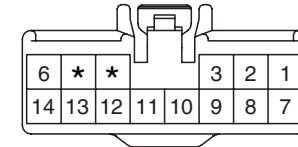

KET\_090III\_14F\_W

**M28-C**

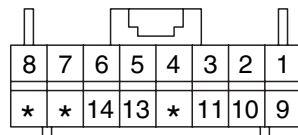

AMP\_0407\_16F\_W\_040

**M28-D**

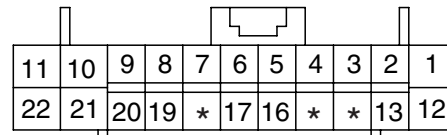

AMP\_0407\_22F\_W\_HD

**M32-A**

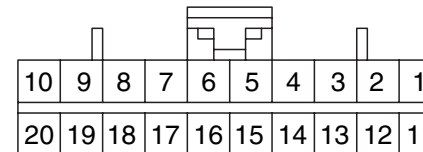

AMP\_040M2\_20F\_B

**M32-C**

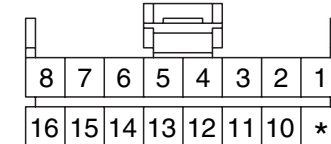

AMP\_040M1\_16F\_B

**M47**

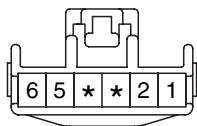

KET\_090II\_06F\_B\_SW

**R01/R03**

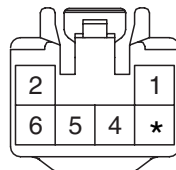

KET\_090III\_06F\_W

**BLANK**

**BLANK**

**TURN & HAZARD LAMPS**

**TURN & HAZARD LAMPS (4)**

**SD925-4**

**MEMO**

**BACK-UP LAMPS (1)**

**SD926-1**

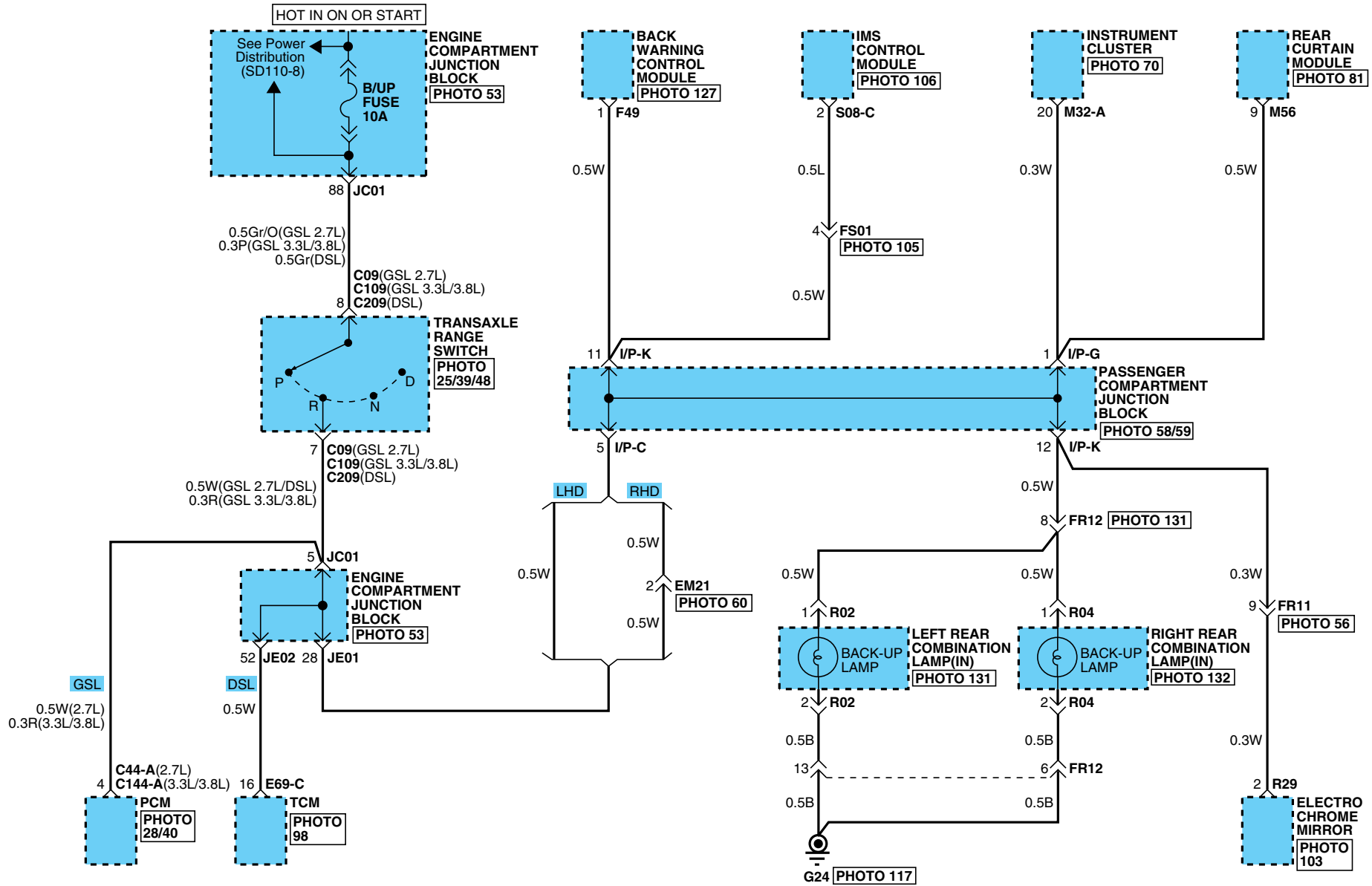

**BACK-UP LAMPS**

**BACK-UP LAMPS (2)**

**SD926-2**

**C44-A**

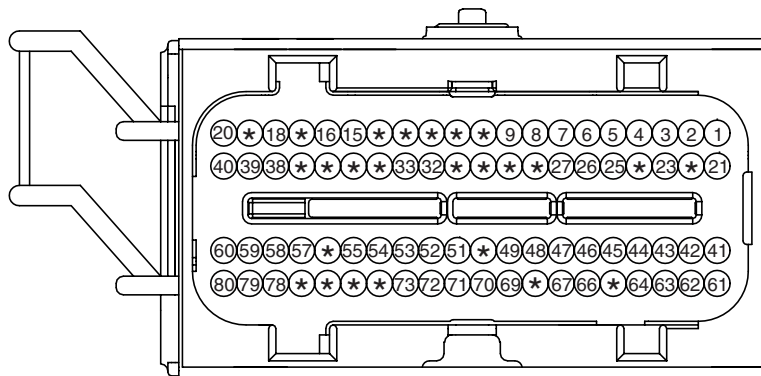

PKD\_ECU\_80F\_Gr\_1

**C144-A**

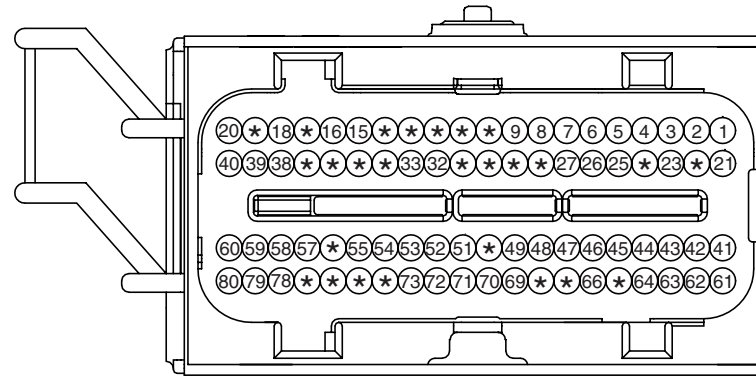

PKD\_ECU\_80F\_B\_1

**C09/C109/C209**



KET\_SSD\_10F\_B\_A

**E69-C**

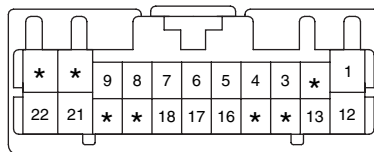

KET\_0407\_22F\_W

**F49**

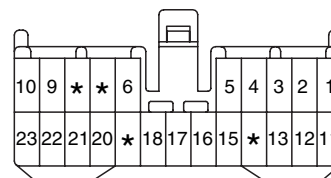

KET\_050\_23F\_W

**M32-A**

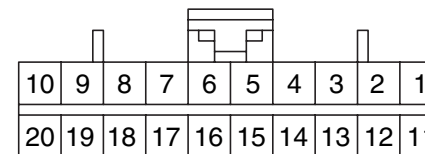

AMP\_040M2\_20F\_B

**M56**

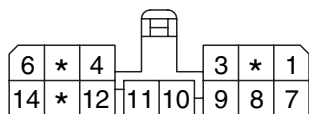

AMP\_070\_14F\_W

**R02/R04**

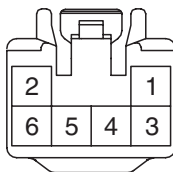

KET\_090III\_06F\_W

**R29**

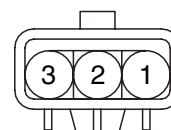

KET\_TLCWP\_03F\_W

**S08-C**

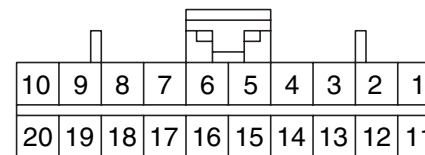

AMP\_040M2\_20F

STOP LAMPS (1)

SD927-1

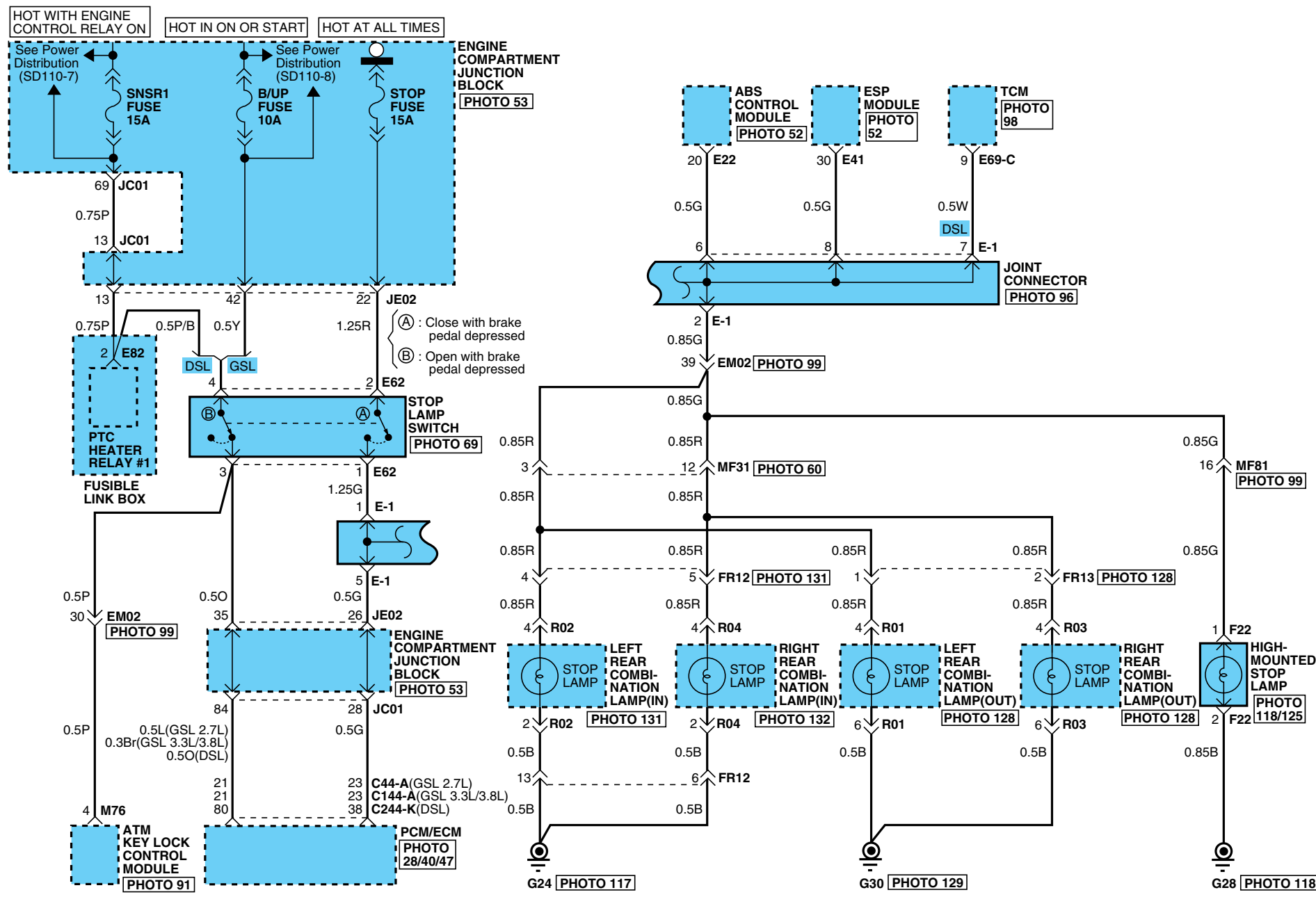



**STOP LAMPS**

**STOP LAMPS (2)**

**SD927-2**

**C44-A**

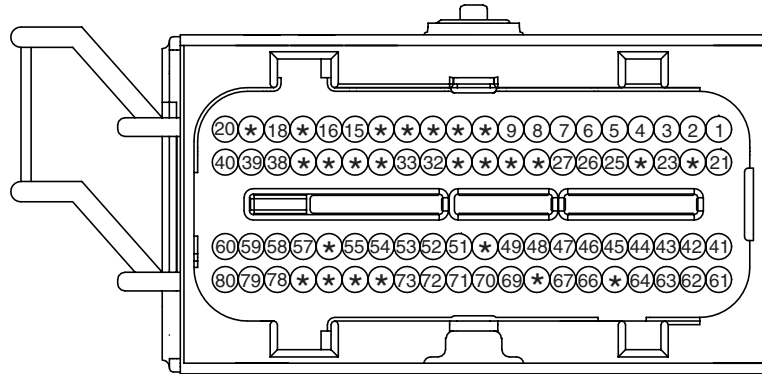

PKD\_ECU\_80F\_Gr\_1

**C144-A**

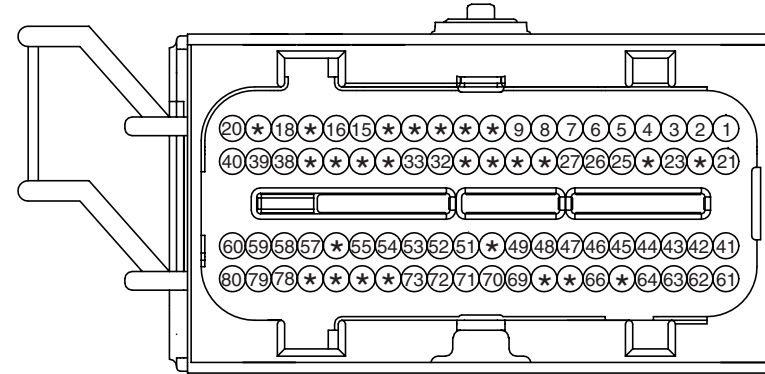

PKD\_ECU\_80F\_B\_1

**C244-K**

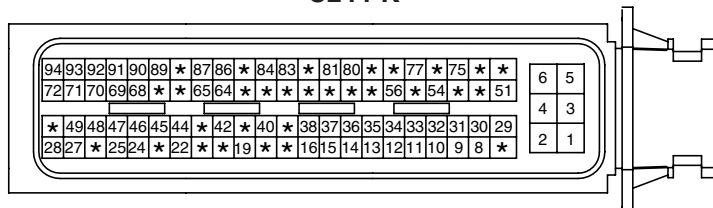

AMP\_ECU\_94F\_B

**BLANK**

**E22**

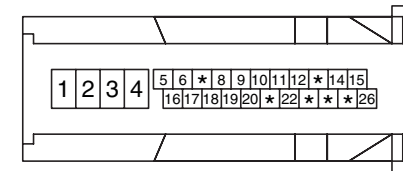

BOS\_ABS\_26F\_B\_L

**E41**

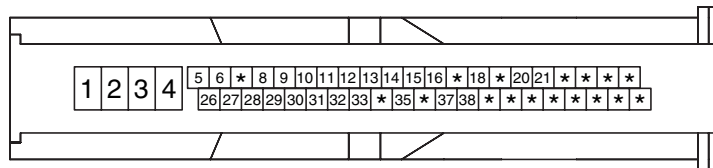

BOS\_ESP\_46F\_B\_L

**E62**

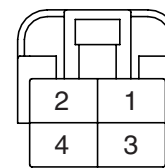

KET\_250DL\_04F\_W

**E69-C**

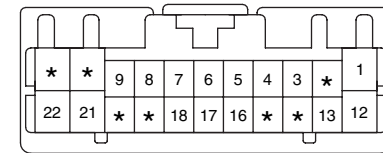

KET\_0407\_22F\_W

**F22**

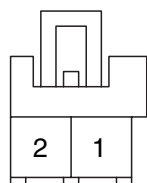

KUM\_CDR\_02F\_W

**M76**

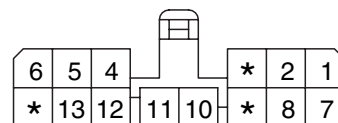

AMP\_070\_14F\_W

**R01/R03**

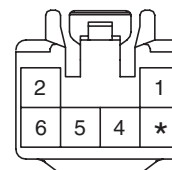

KET\_090III\_06F\_W

**R02/R04**

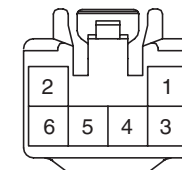

KET\_090III\_06F\_W

TAIL, PARKING & LICENSE LAMPS (1)

SD928-1

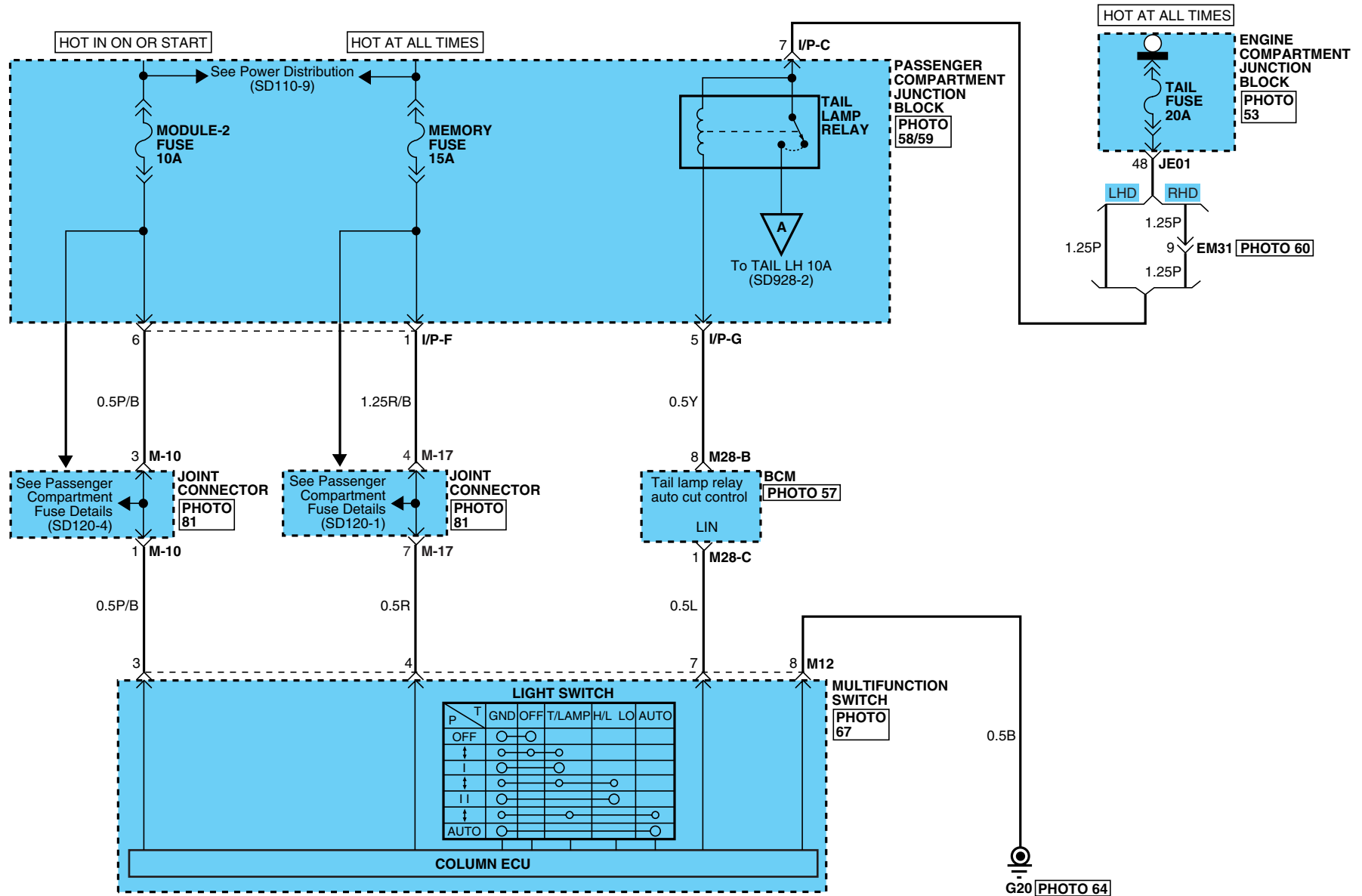

# TAIL, PARKING & LICENSE LAMPS

## TAIL, PARKING & LICENSE LAMPS (2)

SD928-2

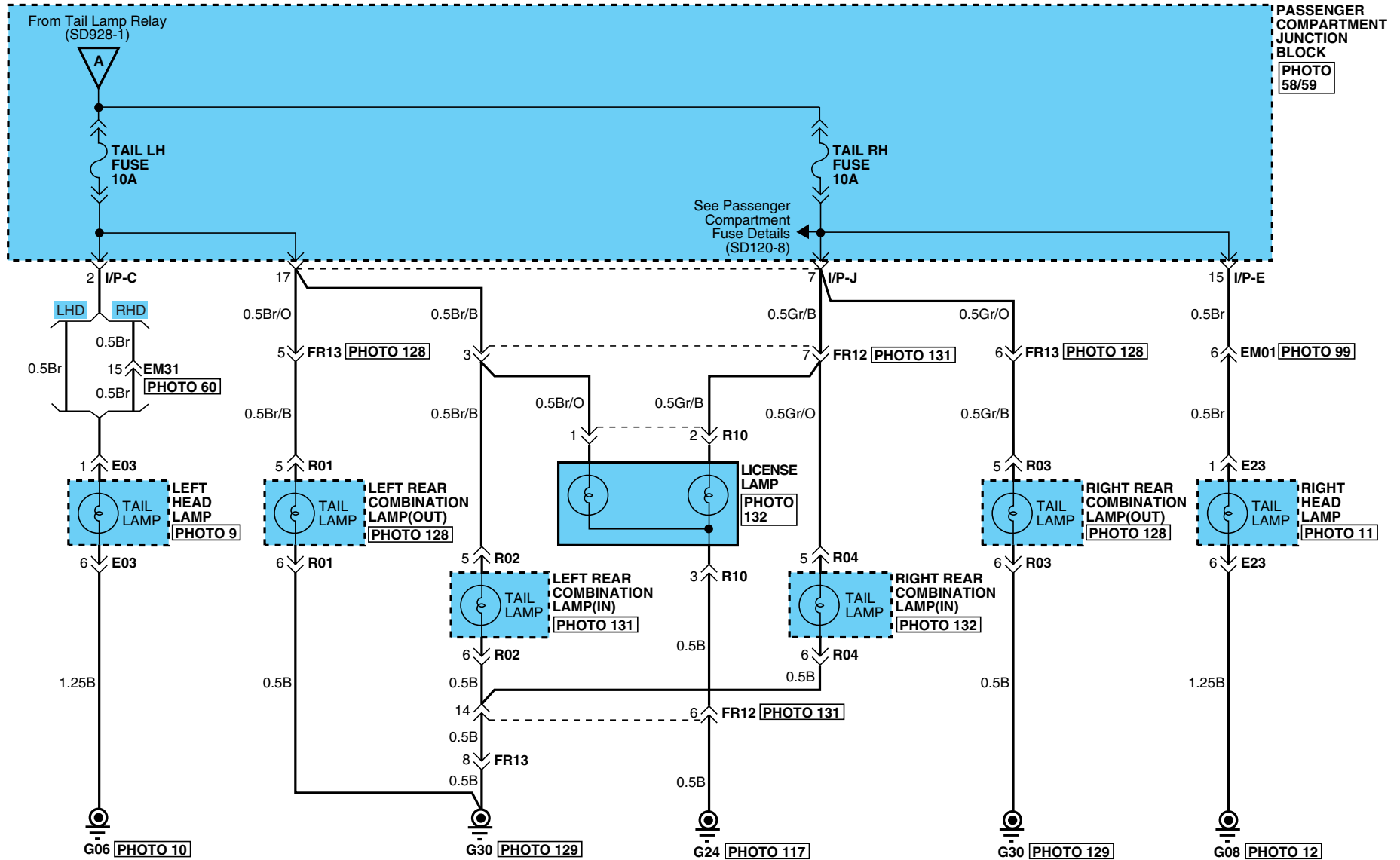

# TAIL, PARKING & LICENSE LAMPS

## TAIL, PARKING & LICENSE LAMPS (3)

SD928-3

**E03**

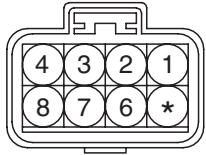

KUM\_NMWP\_08F\_B

**E23**

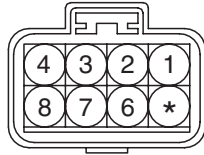

KUM\_NMWP\_08F\_B

**M12**

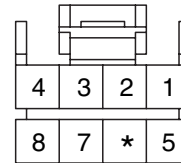

AMP\_040M1\_08F\_B

**M28-B**

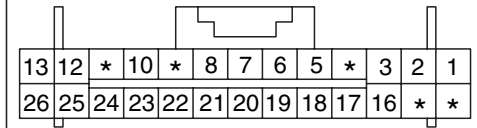

AMP\_0407\_26F\_W\_HD

**M28-C**

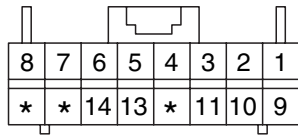

AMP\_0407\_16F\_W\_040

**R01**

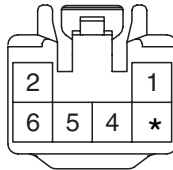

KET\_090III\_06F\_W

**R02**

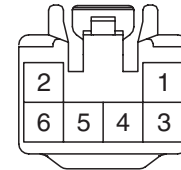

KET\_090III\_06F\_W

**R03**

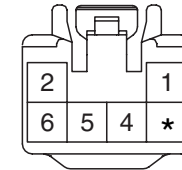

KET\_090III\_06F\_W

**R04**

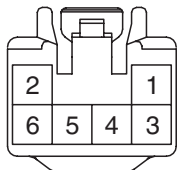

KET\_090III\_06F\_W

**R10**

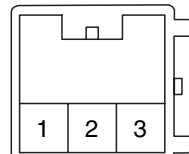

KUM\_CDR\_03M\_W

**BLANK**

**BLANK**

**TAIL, PARKING & LICENSE LAMPS**

**TAIL, PARKING & LICENSE LAMPS (4)**

**SD928-4**

**MEMO**

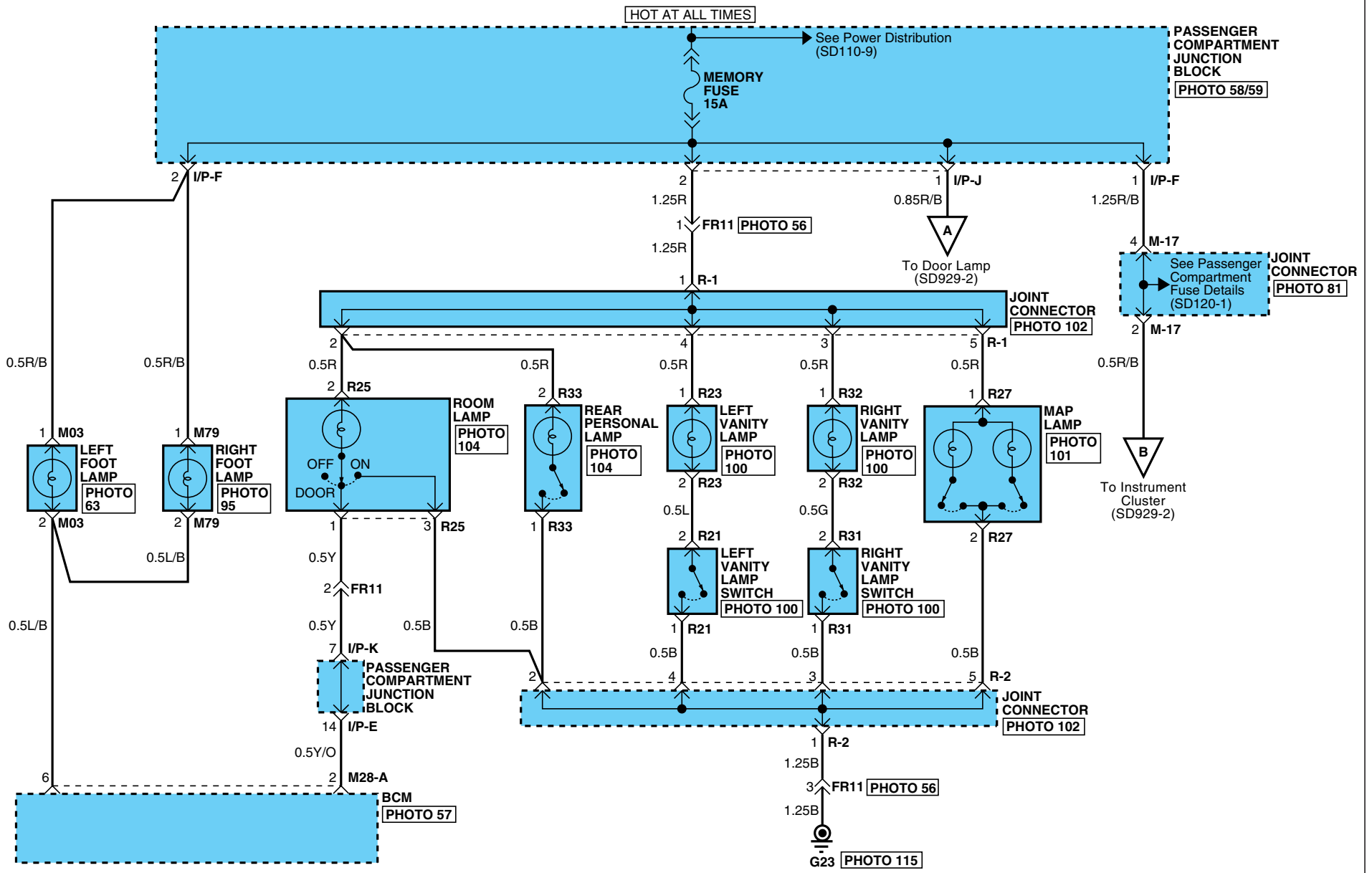

# COURTESY & TRUNK ROOM LAMPS

## COURTESY & TRUNK ROOM LAMPS (2)

SD929-2

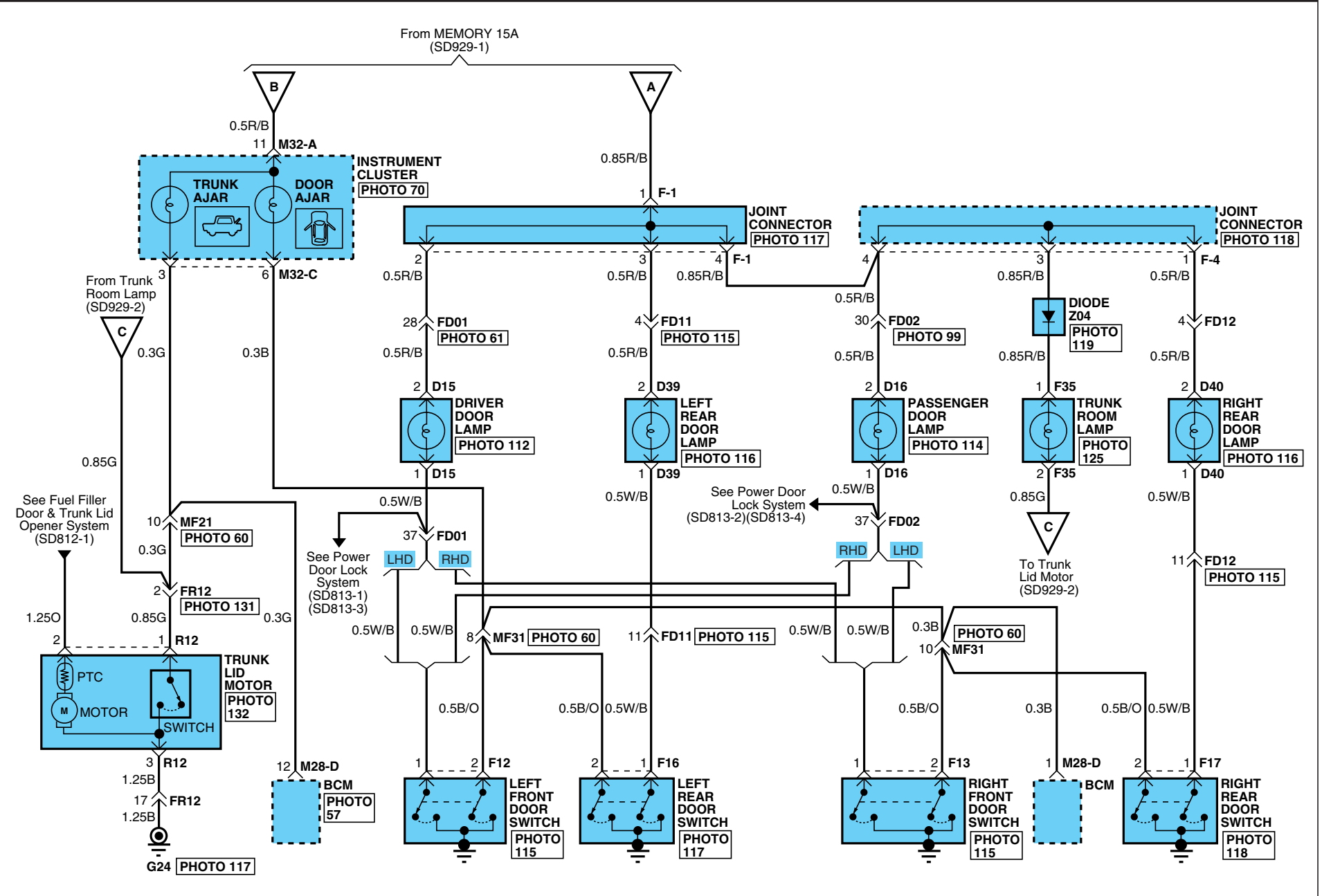

**COURTESY & TRUNK ROOM LAMPS**

**COURTESY & TRUNK ROOM LAMPS (3)**

**SD929-3**

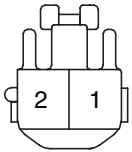
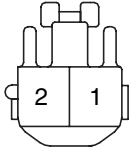
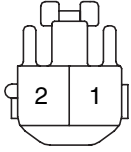
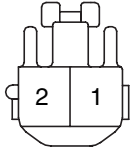
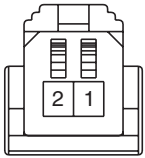
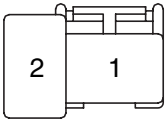
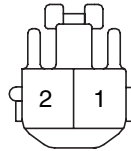
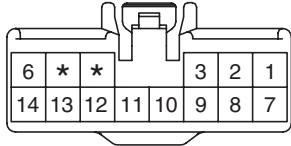
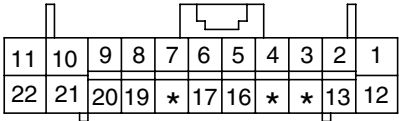
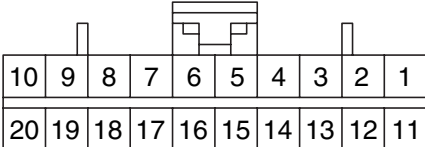
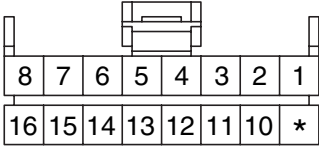
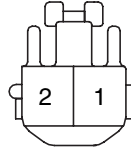
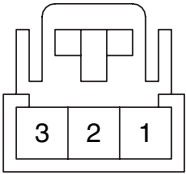
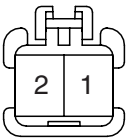
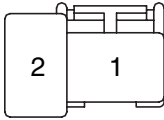
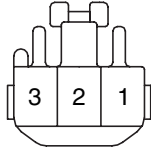
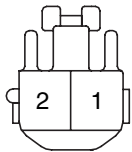
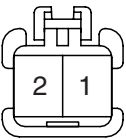
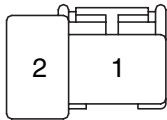
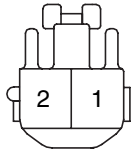
<p><b>D15</b></p>  <p>KET_090III_02F_L_L</p>	<p><b>D16</b></p>  <p>KET_090III_02F_L_L</p>	<p><b>D39</b></p>  <p>KET_090III_02F_L_L</p>	<p><b>D40</b></p>  <p>KET_090III_02F_L_L</p>
<p><b>F12/F13/F16/F17</b></p>  <p>AMP_040M1_02F_W</p>	<p><b>F35</b></p>  <p>AMP_PLM2_02F_B_DL</p>	<p><b>M03</b></p>  <p>KET_090III_02F_W_L</p>	<p><b>M28-A</b></p>  <p>KET_090III_14F_W</p>
<p><b>M28-D</b></p>  <p>AMP_0407_22F_W_HD</p>	<p><b>M32-A</b></p>  <p>AMP_040M2_20F_B</p>	<p><b>M32-C</b></p>  <p>AMP_040M1_16F_B</p>	<p><b>M79</b></p>  <p>KET_090III_02F_W_L</p>
<p><b>R12</b></p>  <p>AMP_070_03F_W_HOR</p>	<p><b>R21</b></p>  <p>KET_090_02F_W_PBT</p>	<p><b>R23</b></p>  <p>AMP_PLM2_02F_B_DL</p>	<p><b>R25</b></p>  <p>KET_090II_03F_W</p>
<p><b>R27</b></p>  <p>KET_090III_02F_W_L</p>	<p><b>R31</b></p>  <p>KET_090_02F_W_PBT</p>	<p><b>R32</b></p>  <p>AMP_PLM2_02F_B_DL</p>	<p><b>R33</b></p>  <p>KET_090III_02F_W_L</p>



**COURTESY & TRUNK ROOM LAMPS**

**COURTESY & TRUNK ROOM LAMPS (4)**

**SD929-4**

**MEMO**

INDICATORS & GAUGES (SUPER VISION TYPE) (1)

SD940-1

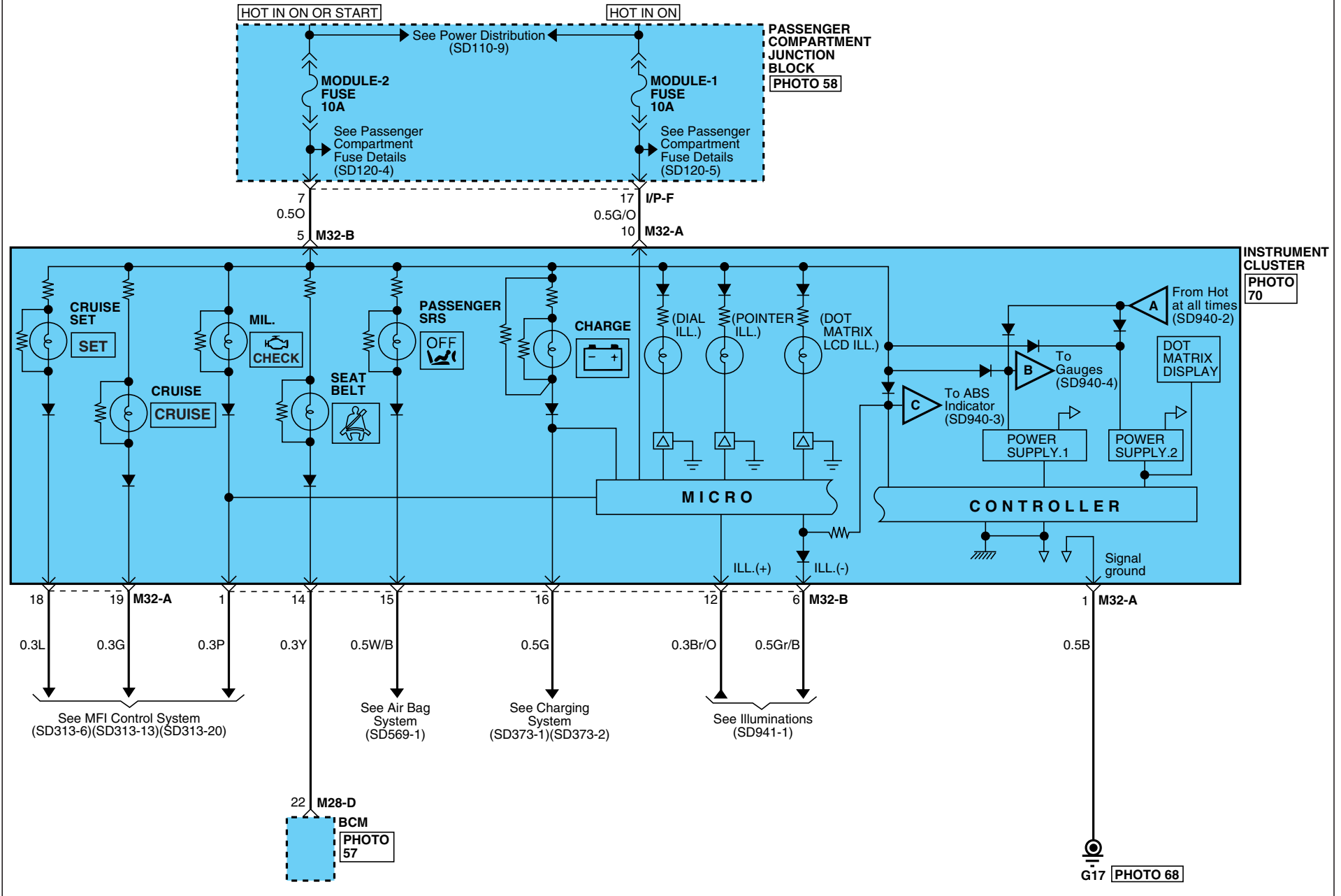

# INDICATORS & GAUGES

## INDICATORS & GAUGES (SUPER VISION TYPE) (2)

SD940-2

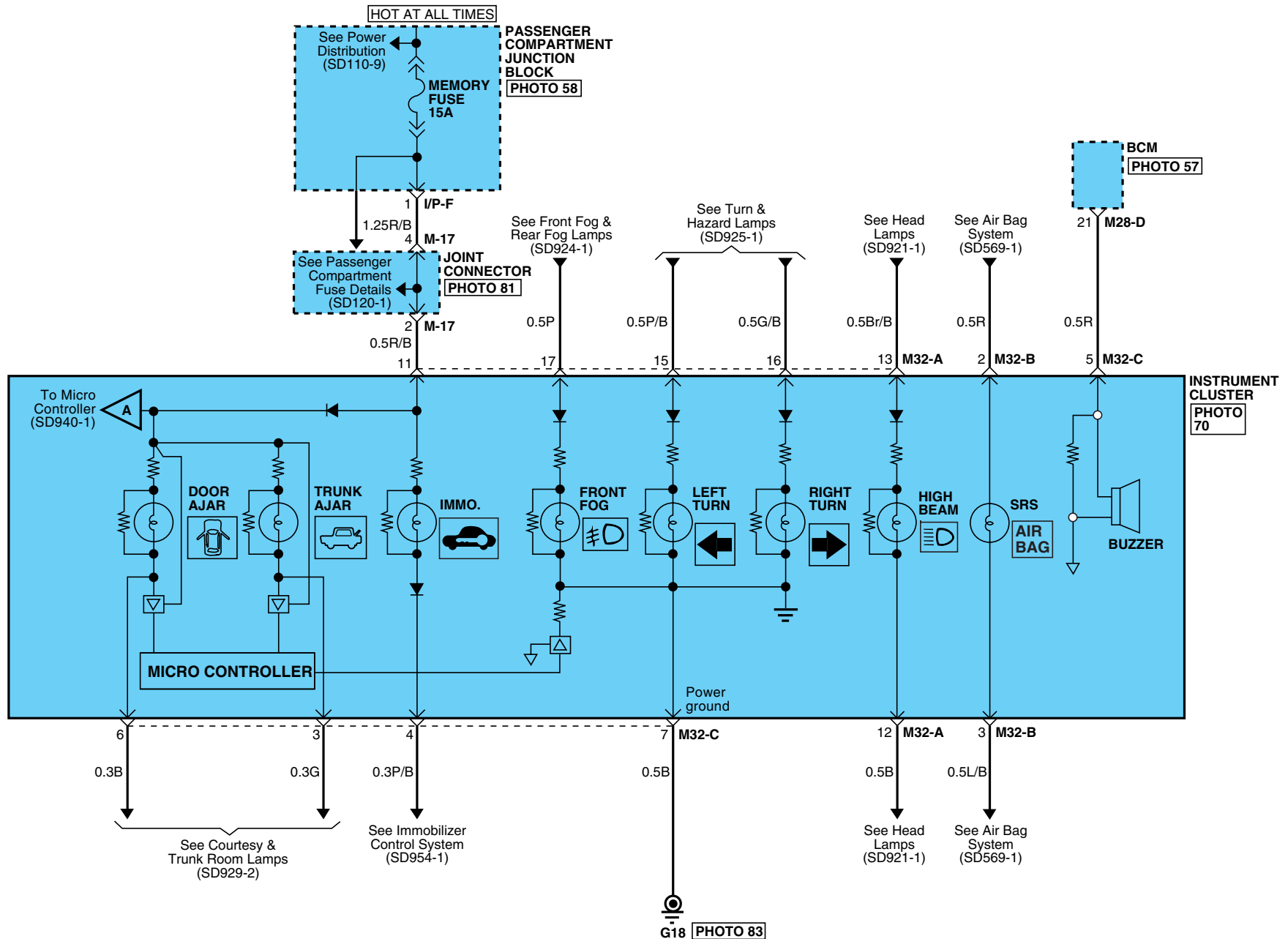

# INDICATORS & GAUGES

## INDICATORS & GAUGES (SUPER VISION TYPE) (3)

SD940-3

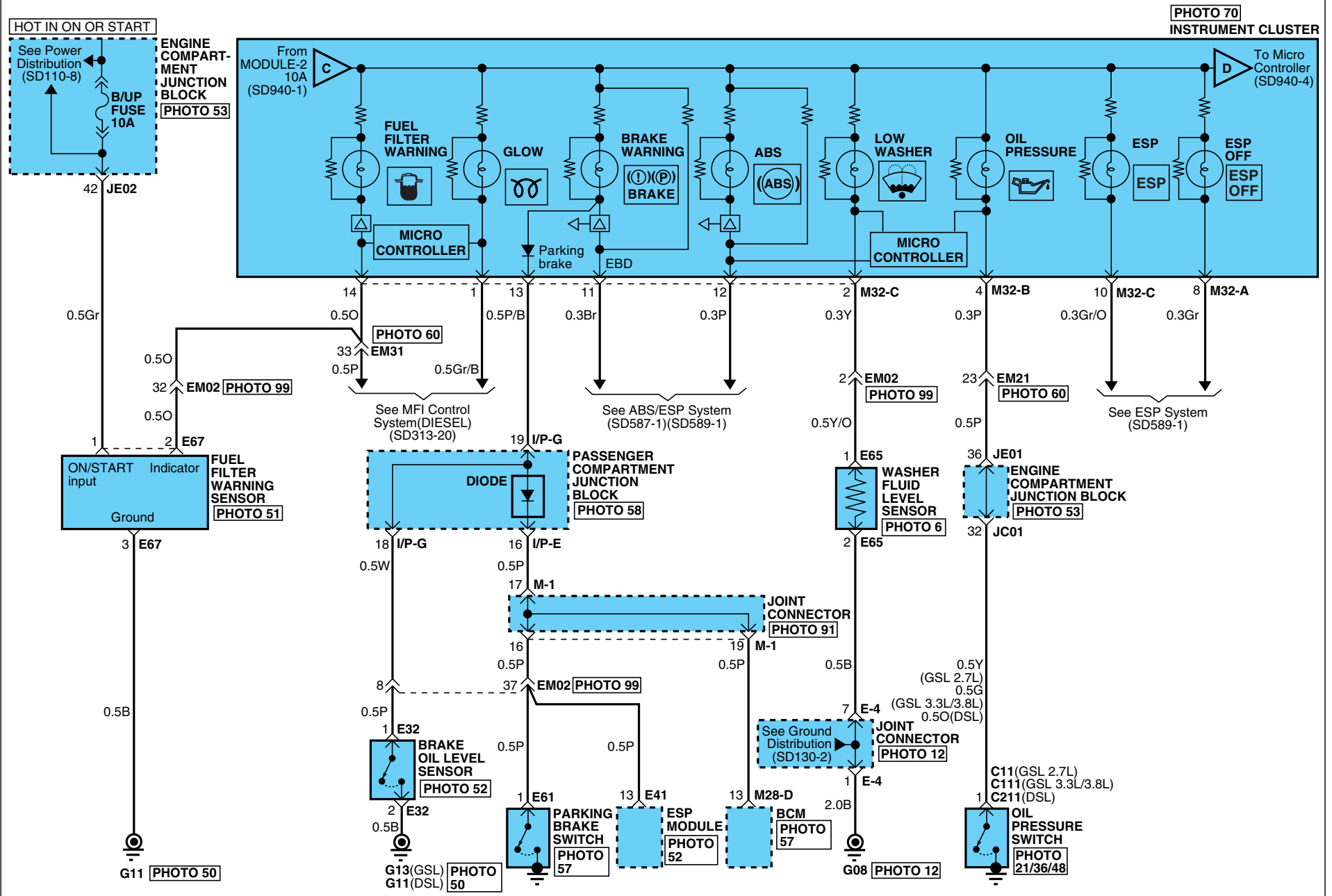

**INDICATORS & GAUGES**

**INDICATORS & GAUGES (SUPER VISION TYPE) (4)**

**SD940-4**

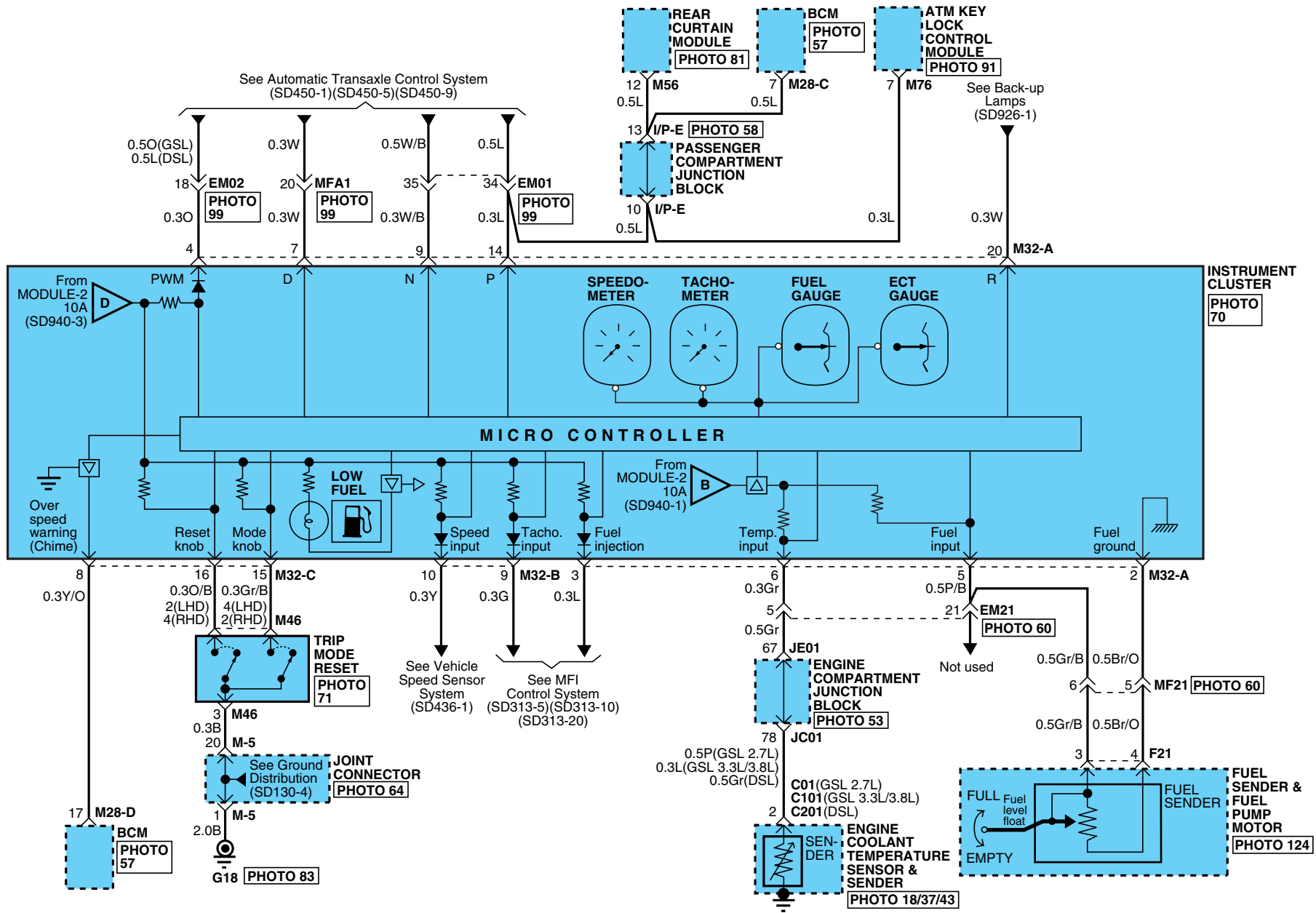

# INDICATORS & GAUGES

## INDICATORS & GAUGES (SUPER VISION TYPE) (5)

SD940-5

**C01/C201**

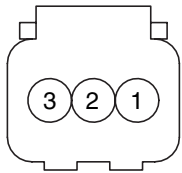

KUM\_WTS\_03F\_B

**C11/C111/C211**



KUM\_NMWP\_01F\_B

**C101**

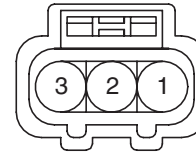

KUM\_62Z\_03F\_B\_WTS

**E32**

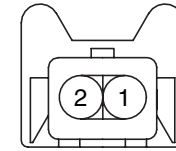

AMP\_JPT\_02F\_B\_CLIP

**E41**

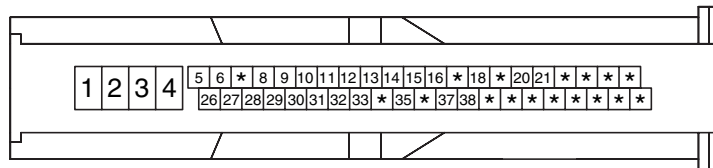

BOS\_ESP\_46F\_B\_L

**E61**

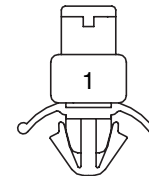

KET\_250\_01F\_B\_CLIP

**E65**

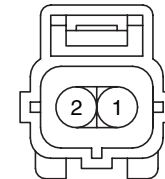

AMP\_EJWP\_02F\_B

**E67**



AMP\_090\_03F\_B\_WP

**F21**

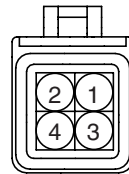

AMP\_MCP\_E\_04F\_B

**M28-C**

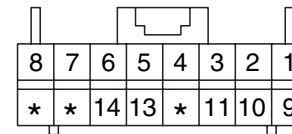

AMP\_0407\_16F\_W\_040

**M28-D**

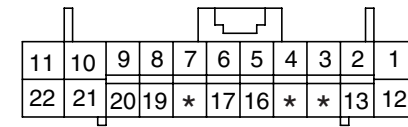

AMP\_0407\_22F\_W\_HD

**M32-A**

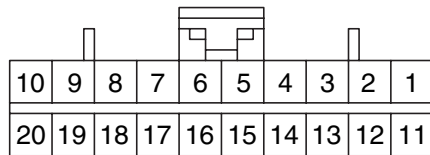

AMP\_040M2\_20F\_B

**M32-B**

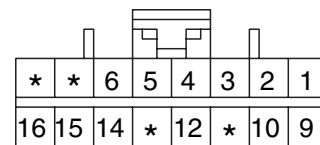

AMP\_040M2\_16F\_B

**M32-C**

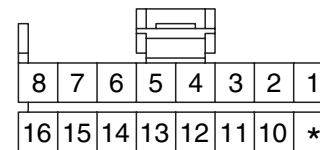

AMP\_040M1\_16F\_B

**M46**

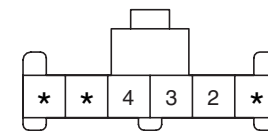

KET\_91A\_06F\_W

**M56**

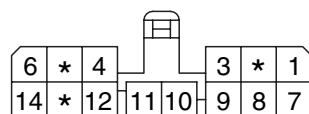

AMP\_070\_14F\_W

**M76**

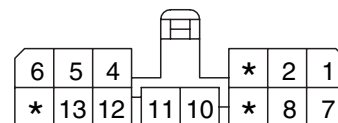

AMP\_070\_14F\_W

**BLANK**

**BLANK**

**INDICATORS & GAUGES**

**INDICATORS & GAUGES (SUPER VISION TYPE) (6)**

**SD940-6**

**MEMO**

# INDICATORS & GAUGES

## INDICATORS & GAUGES (ANALOG TYPE) (1)

SD940-7

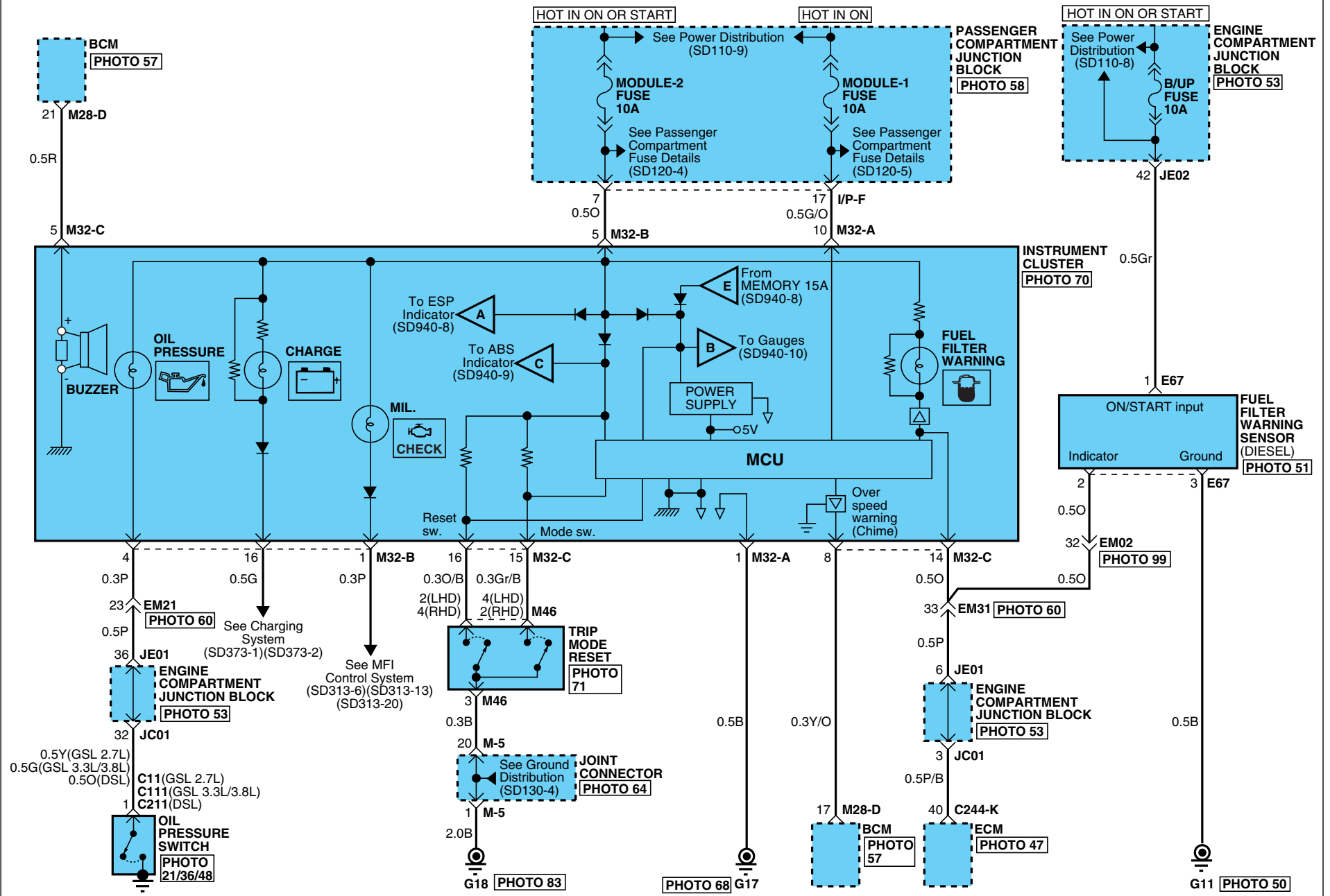



# INDICATORS & GAUGES

## INDICATORS & GAUGES (ANALOG TYPE) (2)

SD940-8

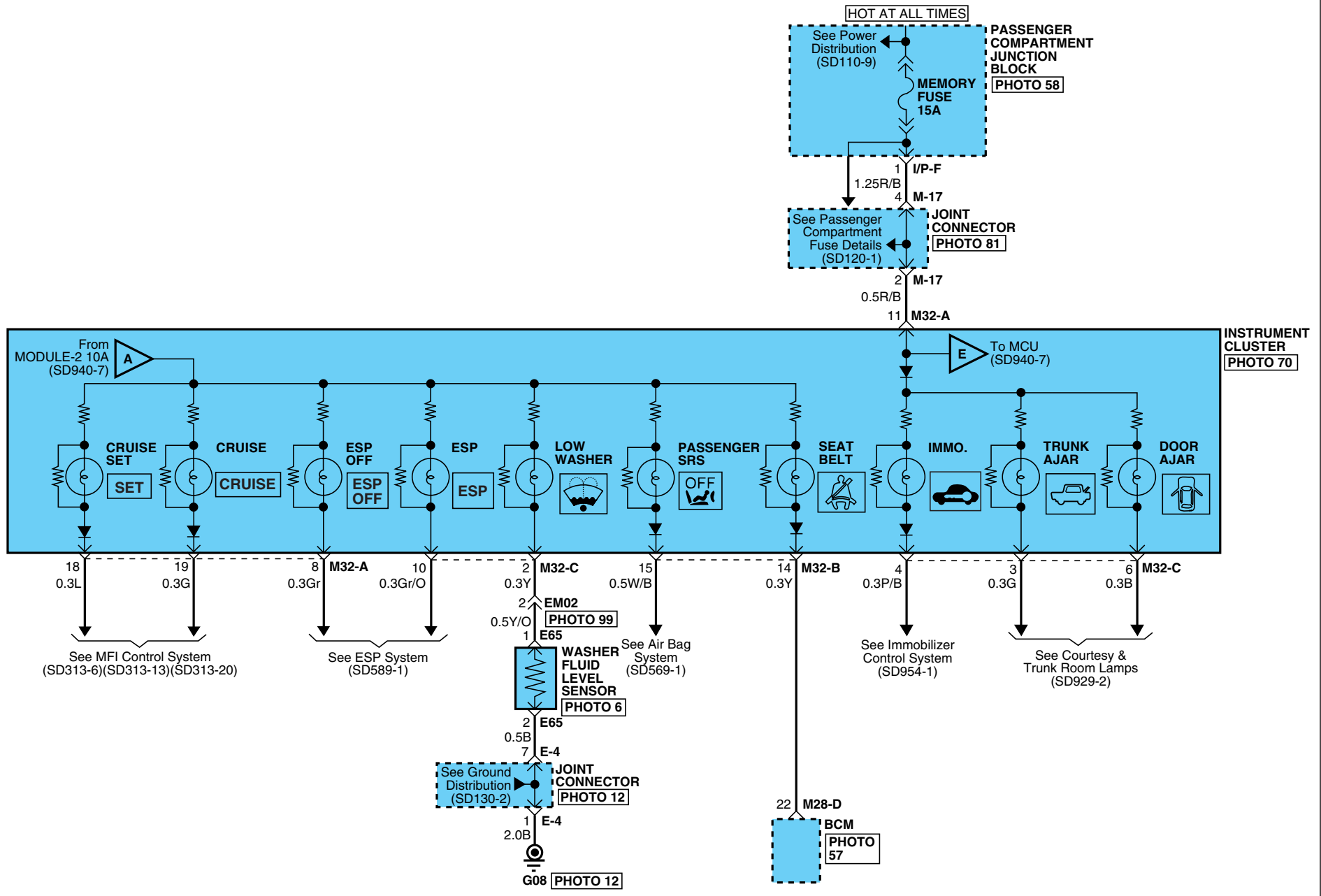

# INDICATORS & GAUGES

## INDICATORS & GAUGES (ANALOG TYPE) (3)

SD940-9

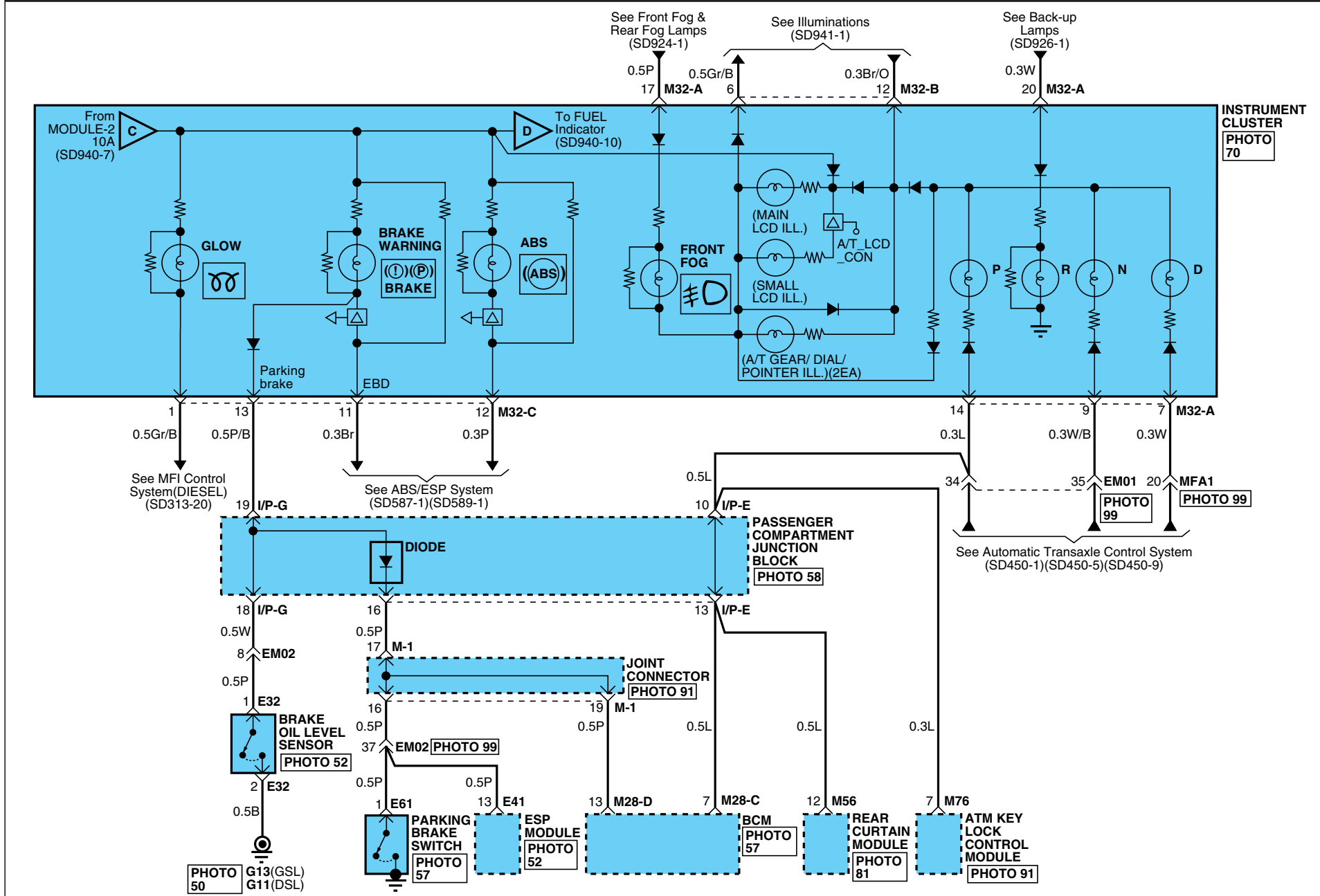

# INDICATORS & GAUGES

## INDICATORS & GAUGES (ANALOG TYPE) (4)



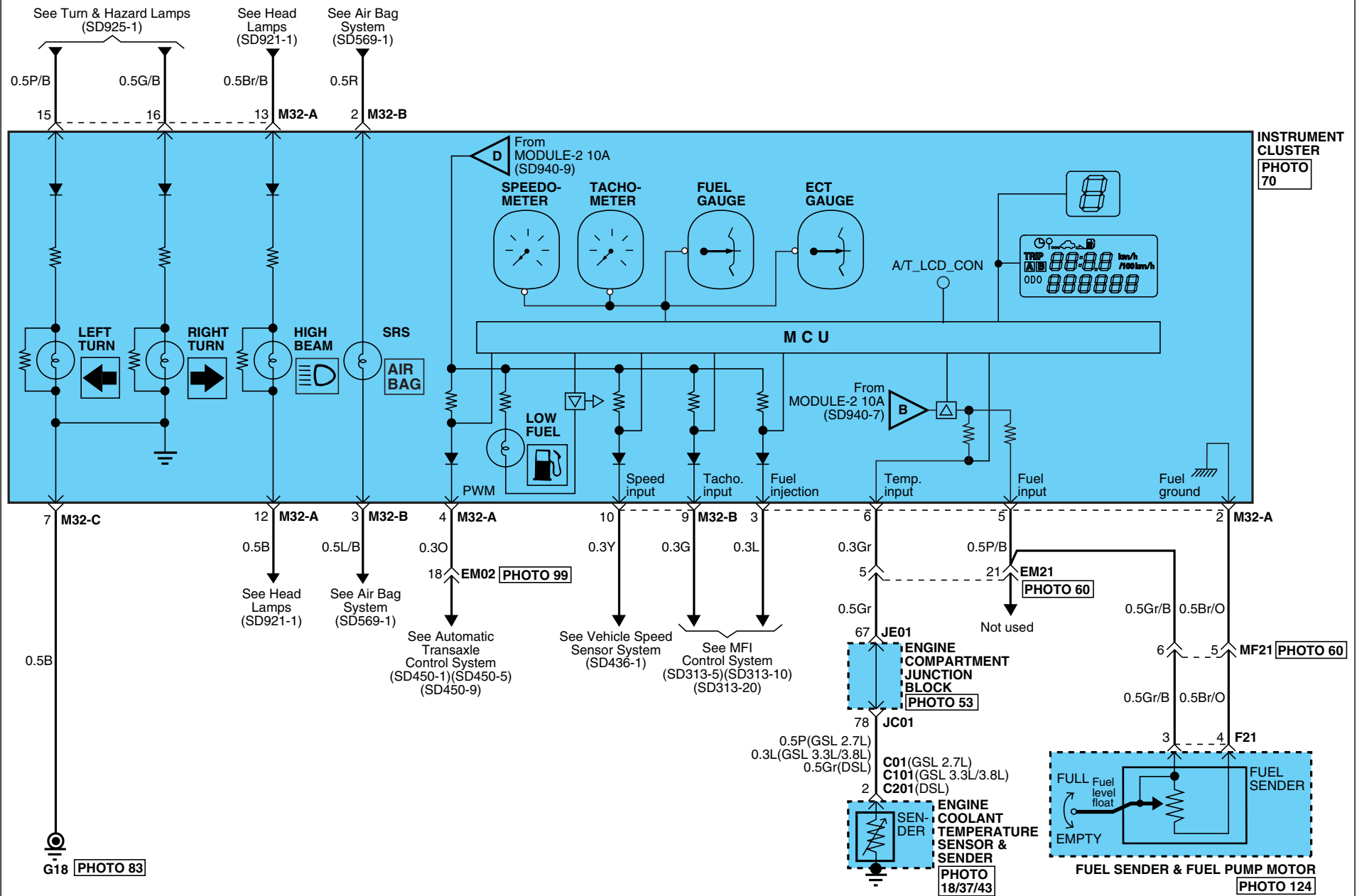

SD940-10

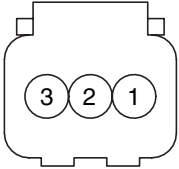

# INDICATORS & GAUGES

## INDICATORS & GAUGES (ANALOG TYPE) (5)

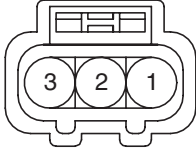
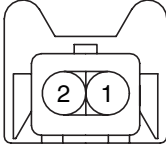
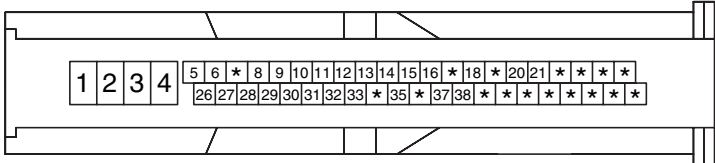
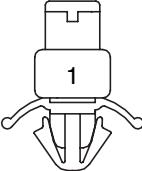
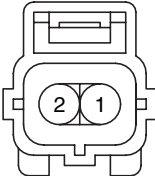
SD940-11

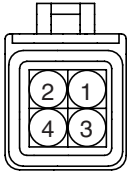
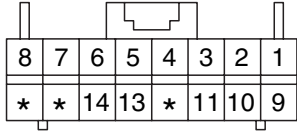
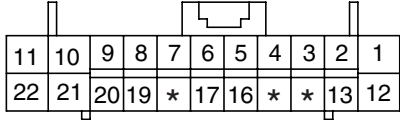
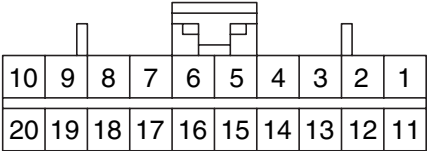
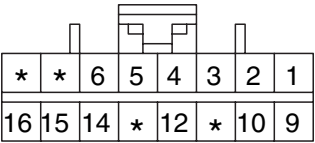
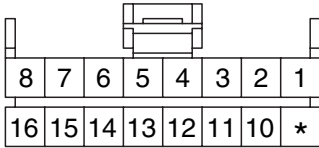
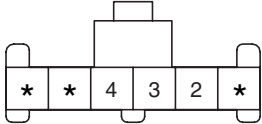
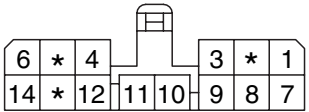
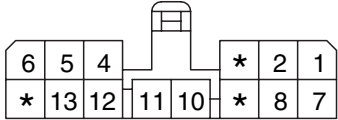
<p><b>C01/C201</b></p>  <p>KUM_WTS_03F_B</p>	<p><b>C11/C111/C211</b></p>  <p>KUM_NMWP_01F_B</p>	<p><b>C101</b></p>  <p>KUM_62Z_03F_B_WTS</p>	<p><b>E32</b></p>  <p>AMP_JPT_02F_B_CLIP</p>
<p><b>E41</b></p>  <p>BOS_ESP_46F_B_L</p>		<p><b>E61</b></p>  <p>KET_250_01F_B_CLIP</p>	<p><b>E65</b></p>  <p>AMP_EJWP_02F_B</p>
<p><b>E67</b></p>  <p>AMP_090_03F_B_WP</p>	<p><b>F21</b></p>  <p>AMP_MCP_E_04F_B</p>	<p><b>M28-C</b></p>  <p>AMP_0407_16F_W_040</p>	<p><b>M28-D</b></p>  <p>AMP_0407_22F_W_HD</p>
<p><b>M32-A</b></p>  <p>AMP_040M2_20F_B</p>	<p><b>M32-B</b></p>  <p>AMP_040M2_16F_B</p>	<p><b>M32-C</b></p>  <p>AMP_040M1_16F_B</p>	<p><b>M46</b></p>  <p>KET_91A_06F_W</p>
<p><b>M56</b></p>  <p>AMP_070_14F_W</p>	<p><b>M76</b></p>  <p>AMP_070_14F_W</p>	<p><b>BLANK</b></p>	<p><b>BLANK</b></p>

**INDICATORS & GAUGES**

**INDICATORS & GAUGES (ANALOG TYPE) (6)**

**SD940-12**

**MEMO**

ILLUMINATIONS (1)

SD941-1

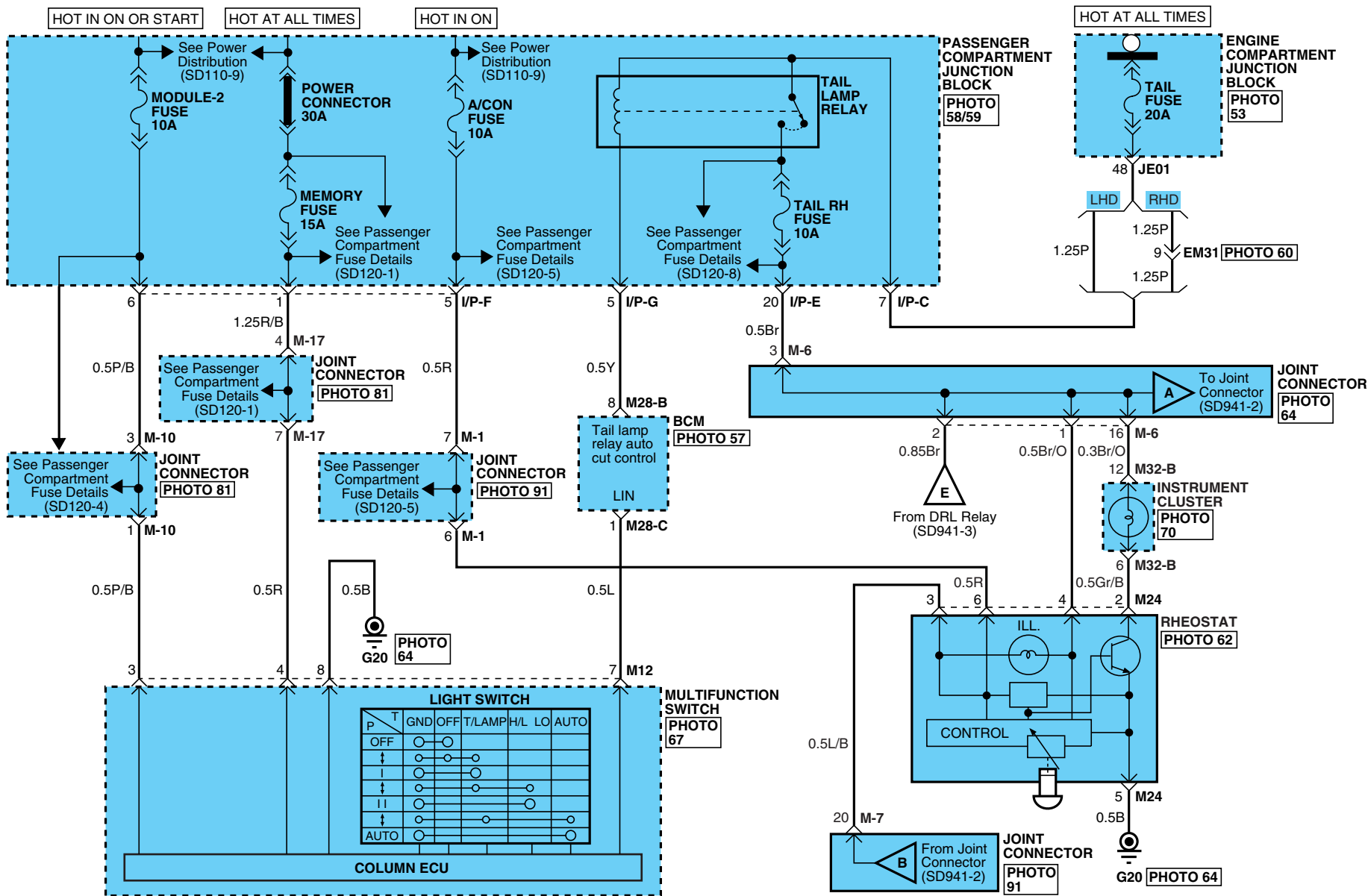

# ILLUMINATIONS

## ILLUMINATIONS (2)

SD941-2

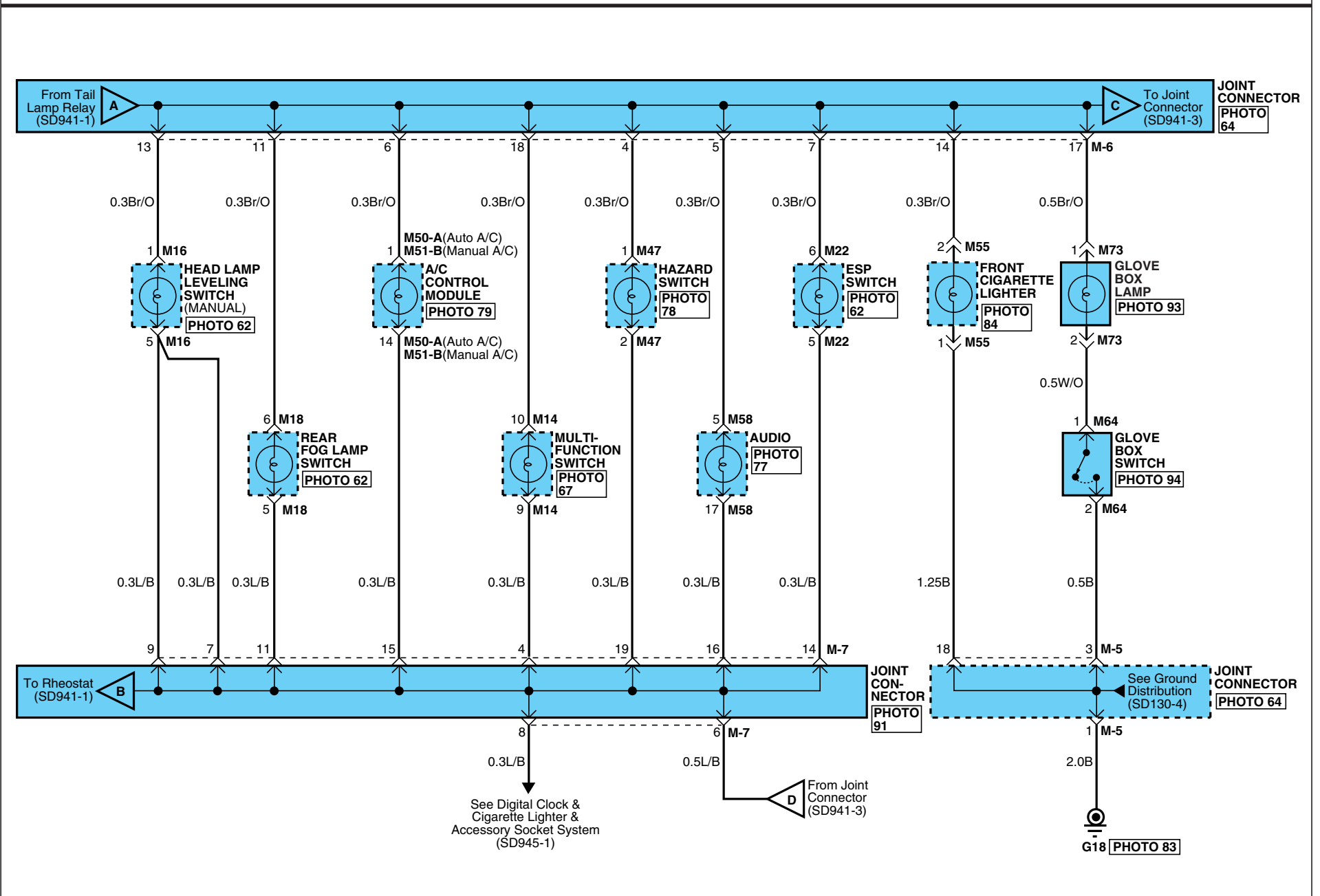

# ILLUMINATIONS

## ILLUMINATIONS (3)

SD941-3

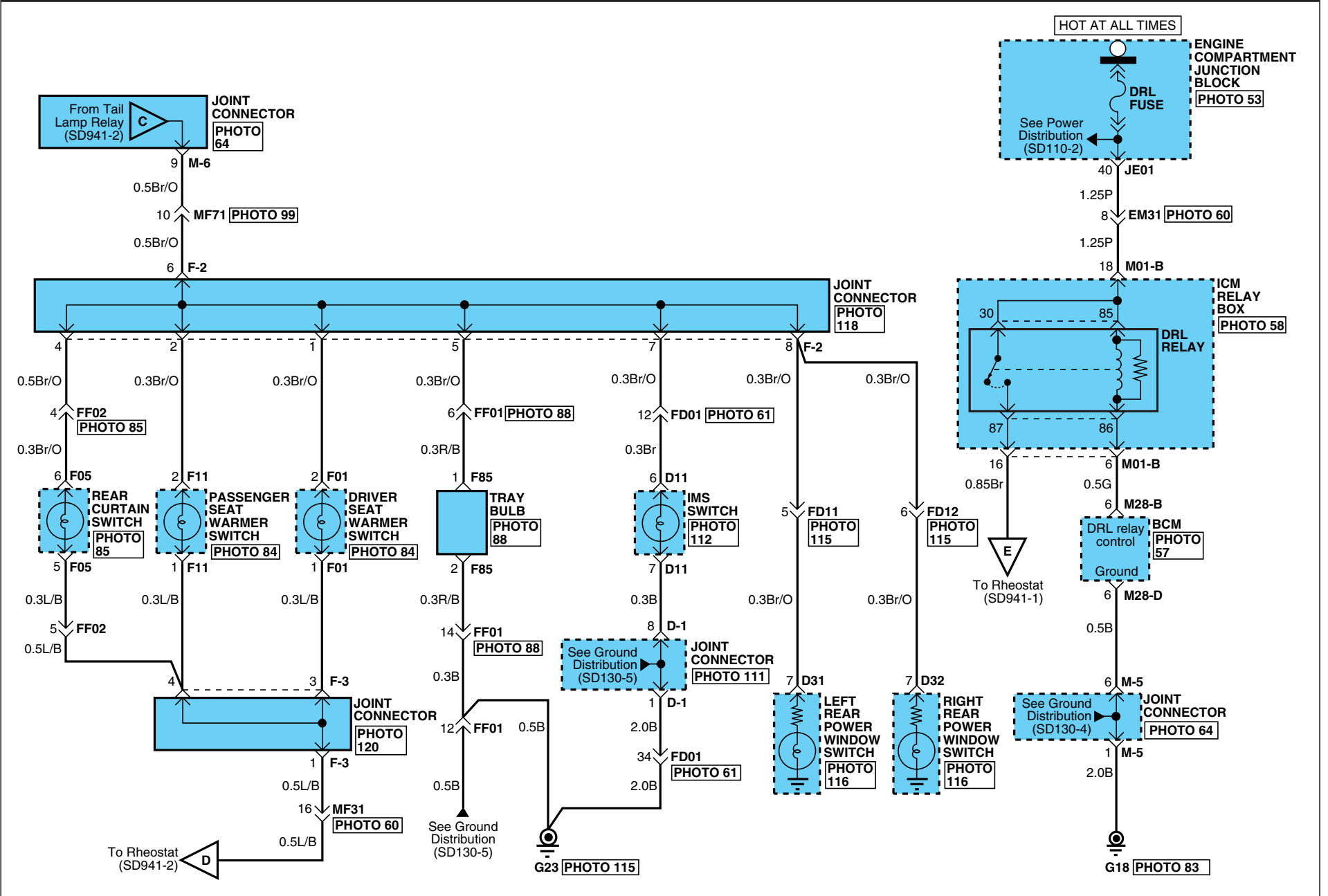

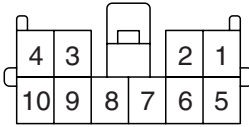
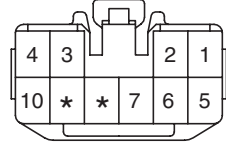
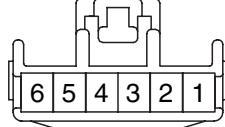
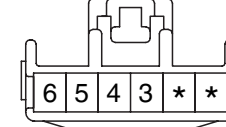
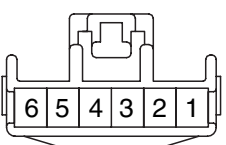
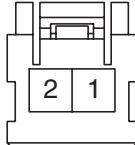
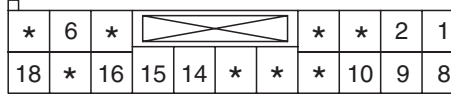
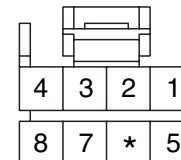
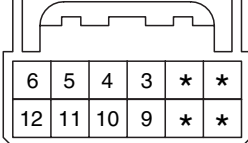
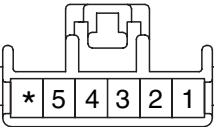
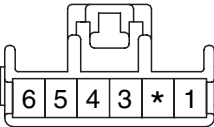
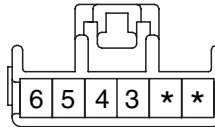
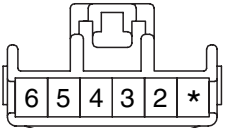
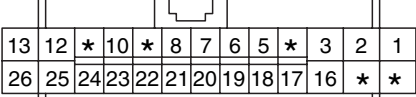
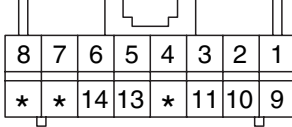
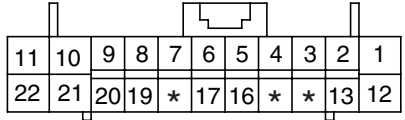
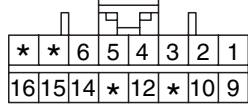
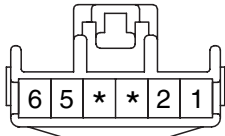
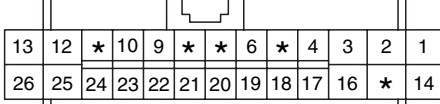
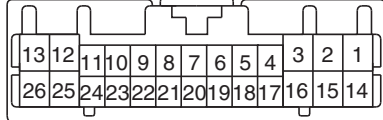

# ILLUMINATIONS

ILLUMINATIONS (4)				SD941-4
<p><b>D11</b></p>  <p>KET_070_10F_W</p>	<p><b>D31/D32</b></p>  <p>KET_090III_10F_W</p>	<p><b>F01</b></p>  <p>KET_090II_06F_L_SW</p>	<p><b>F05</b></p>  <p>KET_090II_06F_L_SW</p>	
<p><b>F11</b></p>  <p>KET_090II_06F_Y_SW</p>	<p><b>F85</b></p>  <p>AMP_090III_02F_B</p>	<p><b>M01-B</b></p>  <p>AMP_0925_18F_W</p>	<p><b>M12</b></p>  <p>AMP_040M1_08F_B</p>	
<p><b>M14</b></p>  <p>AMP_025_12F_W</p>	<p><b>M16</b></p>  <p>KET_090II_06F_L_SW</p>	<p><b>M18</b></p>  <p>KET_090II_06F_Y_SW</p>	<p><b>M22</b></p>  <p>KET_090II_06F_G_SW</p>	
<p><b>M24</b></p>  <p>KET_090II_06F_Gr_SW</p>	<p><b>M28-B</b></p>  <p>AMP_0407_26F_W_HD</p>	<p><b>M28-C</b></p>  <p>AMP_0407_16F_W_040</p>	<p><b>M28-D</b></p>  <p>AMP_0407_22F_W_HD</p>	
<p><b>M32-B</b></p>  <p>AMP_040M2_16F_B</p>	<p><b>M47</b></p>  <p>KET_090II_06F_B_SW</p>	<p><b>M50-A</b></p>  <p>AMP_0407_26F_W_HD</p>	<p><b>M51-B</b></p>  <p>KET_0407_26F_W</p>	

# ILLUMINATIONS

## ILLUMINATIONS (5)

SD941-5

**M55**

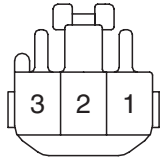

KET\_090III\_03F\_W

**M58**

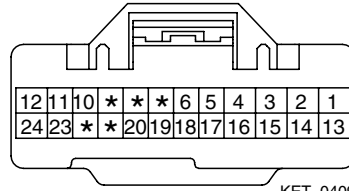

KET\_0409\_24F\_W

**M64**

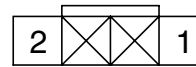

KET\_187\_02F\_W

**M73**

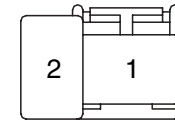

AMP\_PLM2\_02F\_B\_DL

**ILLUMINATIONS**

**ILLUMINATIONS (6)**

**SD941-6**

**MEMO**

# DIGITAL CLOCK & CIGARETTE LIGHTER & ACCESSORY SOCKET SYSTEM

EE1AA9CB

## DIGITAL CLOCK & CIGARETTE LIGHTER & ACCESSORY SOCKET SYSTEM (1)

SD945-1

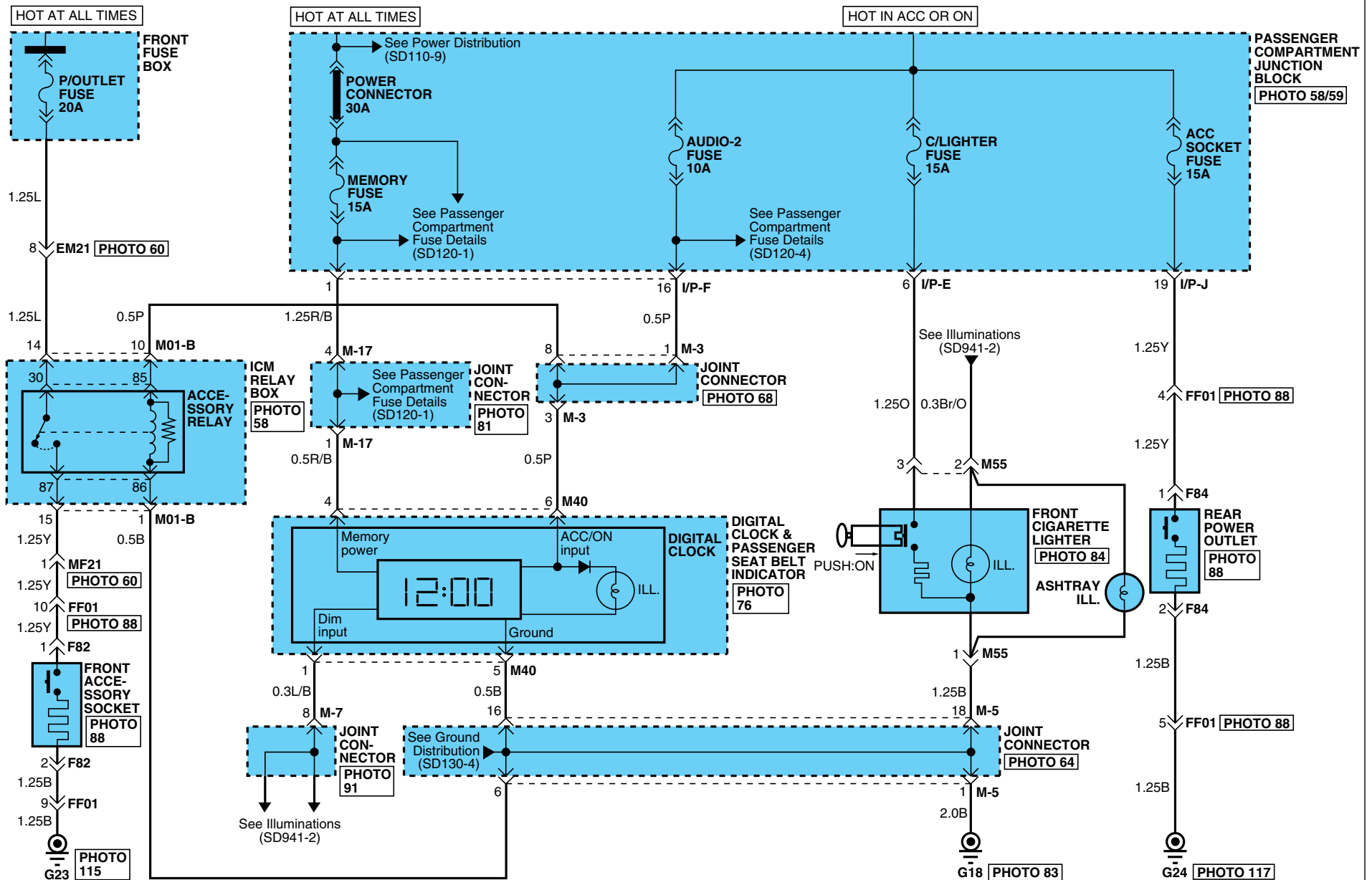

**DIGITAL CLOCK & CIGARETTE LIGHTER & ACCESSORY SOCKET SYSTEM**

**DIGITAL CLOCK & CIGARETTE LIGHTER & ACCESSORY SOCKET SYSTEM (2)**

**SD945-2**

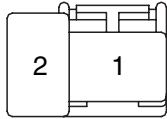
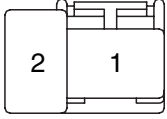
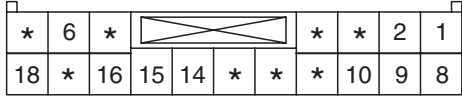
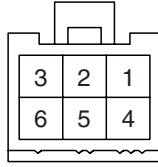
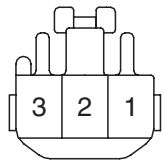
<p style="text-align: center;"><b>F82</b></p>  <p style="text-align: center;">AMP_PLM2_02F_B_DL</p>	<p style="text-align: center;"><b>F84</b></p>  <p style="text-align: center;">AMP_PLM2_02F_B_DL</p>	<p style="text-align: center;"><b>M01-B</b></p>  <p style="text-align: center;">AMP_0925_18F_W</p>	<p style="text-align: center;"><b>M40</b></p>  <p style="text-align: center;">MLX_165_06F_W</p>
<p style="text-align: center;"><b>M55</b></p>  <p style="text-align: center;">KET_090III_03F_W</p>	<p style="text-align: center;"><b>BLANK</b></p>	<p style="text-align: center;"><b>BLANK</b></p>	<p style="text-align: center;"><b>BLANK</b></p>

BCM (BODY CONTROL MODULE) SYSTEM (1)

SD950-1

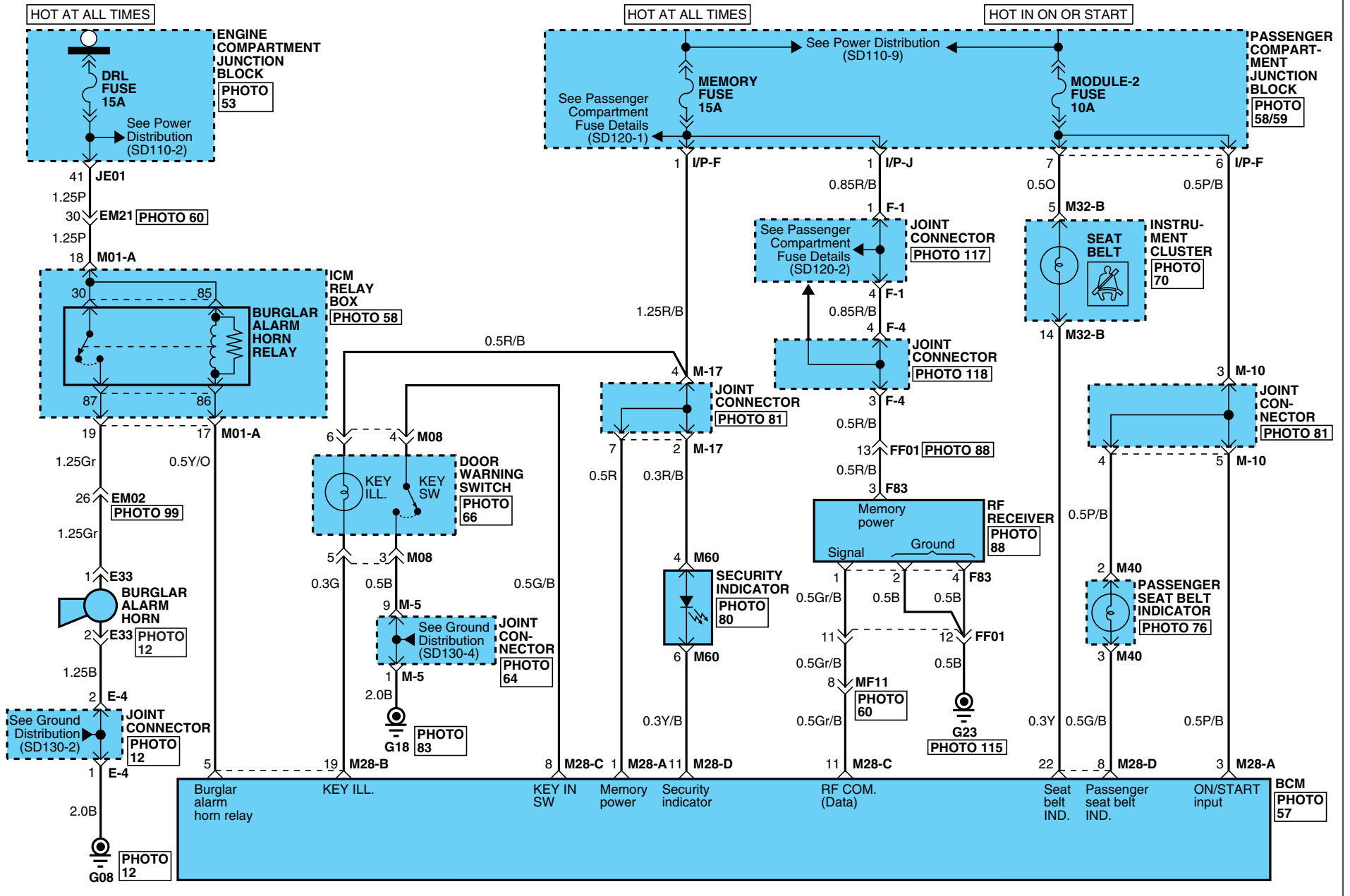

# BCM (BODY CONTROL MODULE) SYSTEM

## BCM (BODY CONTROL MODULE) SYSTEM (2)

SD950-2

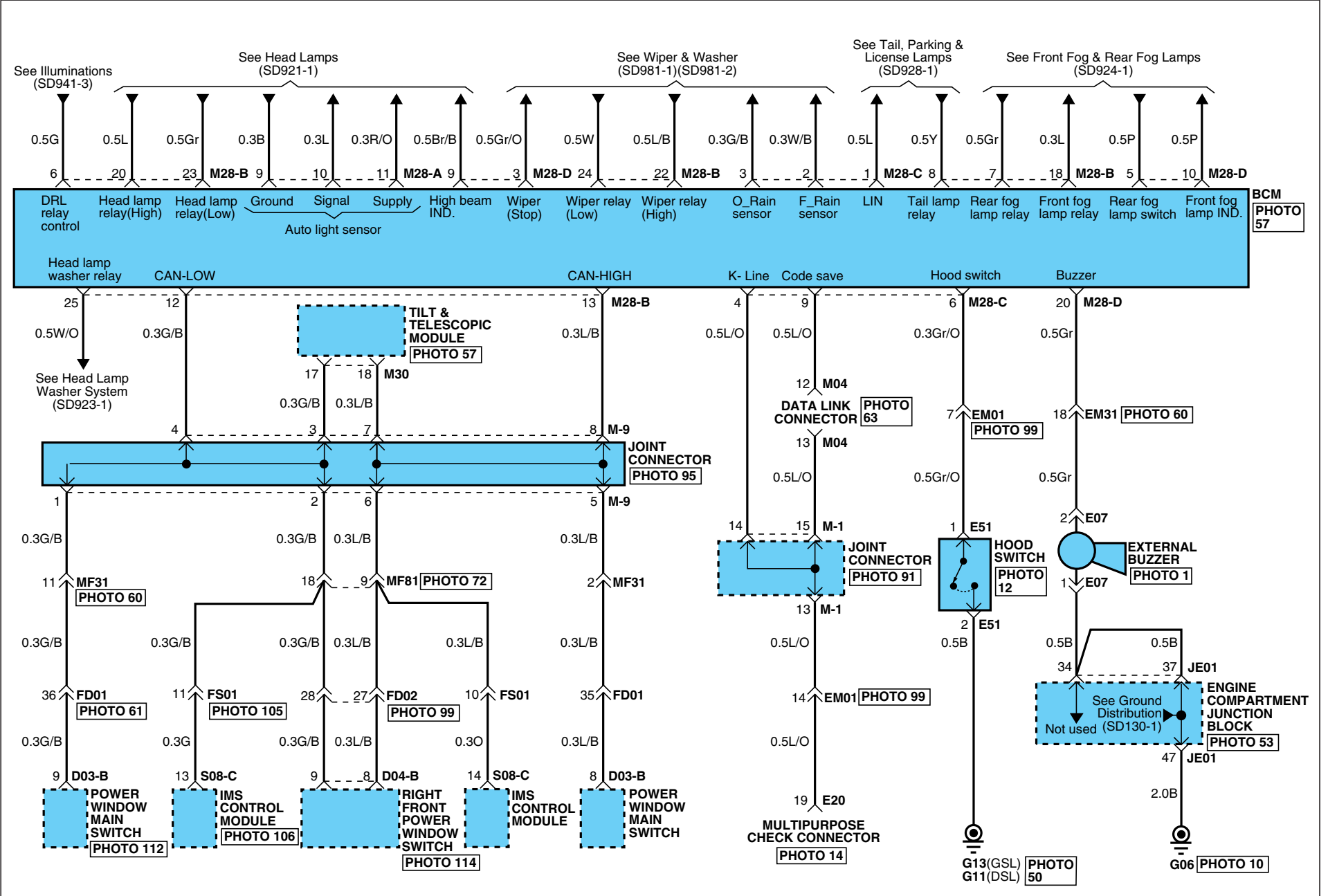

# BCM (BODY CONTROL MODULE) SYSTEM

## BCM (BODY CONTROL MODULE) SYSTEM (3)

SD950-3

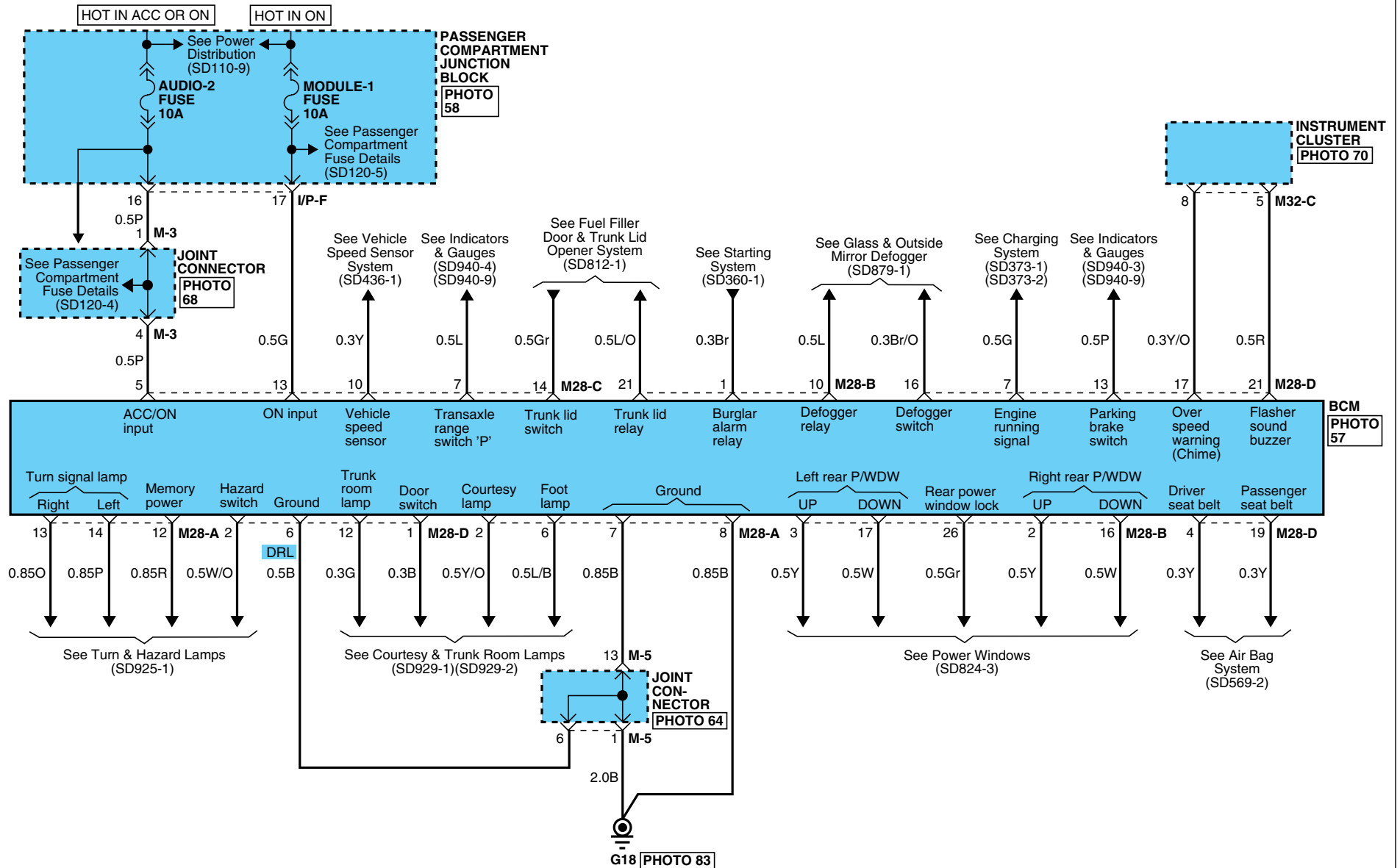



# BCM (BODY CONTROL MODULE) SYSTEM

## BCM (BODY CONTROL MODULE) SYSTEM (4)

SD950-4

<p><b>D03-B</b></p> <p>KET_050_23F_W</p>	<p><b>D04-B</b></p> <p>KET_050_23F_W</p>	<p><b>E07</b></p> <p>SUM_090IWP_02F_B_1</p>	<p><b>E20</b></p> <p>KET_DIAG_20F_B_BRK_A</p>
<p><b>E33</b></p> <p>MLX_HORN_02F_B_FILT</p>	<p><b>E51</b></p> <p>KET_090IWP_02F_B</p>	<p><b>F83</b></p> <p>KET_040III_04F_W</p>	<p><b>M01-A</b></p> <p>AMP_0925_20F_W</p>
<p><b>M04</b></p> <p>MLX_OBDII_16F_B_SIN</p>	<p><b>M08</b></p> <p>KET_090II_06M_W</p>	<p><b>M28-A</b></p> <p>KET_090III_14F_W</p>	<p><b>M28-B</b></p> <p>AMP_0407_26F_W_HD</p>
<p><b>M28-C</b></p> <p>AMP_0407_16F_W_040</p>	<p><b>M28-D</b></p> <p>AMP_0407_22F_W_HD</p>	<p><b>M30</b></p> <p>AMP_0407_26F_B</p>	<p><b>M32-B</b></p> <p>AMP_040M2_16F_B</p>
<p><b>M32-C</b></p> <p>AMP_040M1_16F_B</p>	<p><b>M40</b></p> <p>MLX_165_06F_W</p>	<p><b>M60</b></p> <p>YAZ_91A_06F_W</p>	<p><b>S08-C</b></p> <p>AMP_040M2_20F</p>

IMMOBILIZER CONTROL SYSTEM (1)

SD954-1

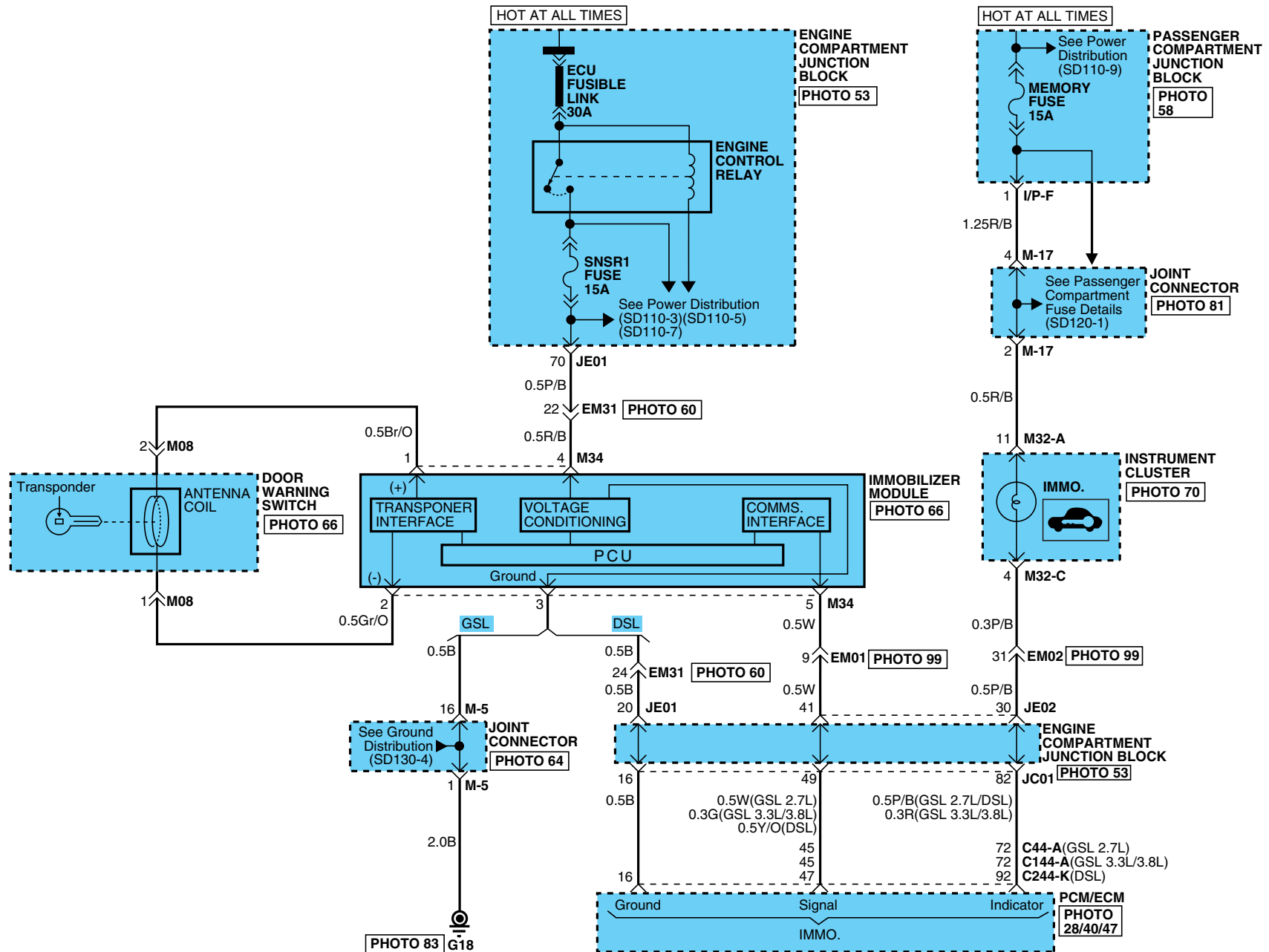

# IMMOBILIZER CONTROL SYSTEM

## IMMOBILIZER CONTROL SYSTEM (2)

SD954-2

**C44-A**

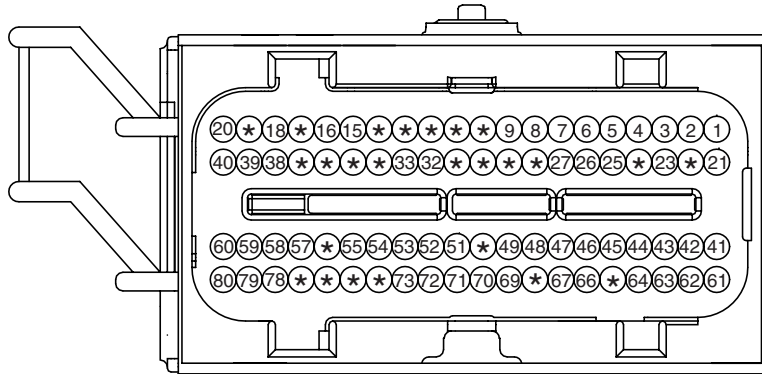

PKD\_ECU\_80F\_Gr\_1

**C144-A**

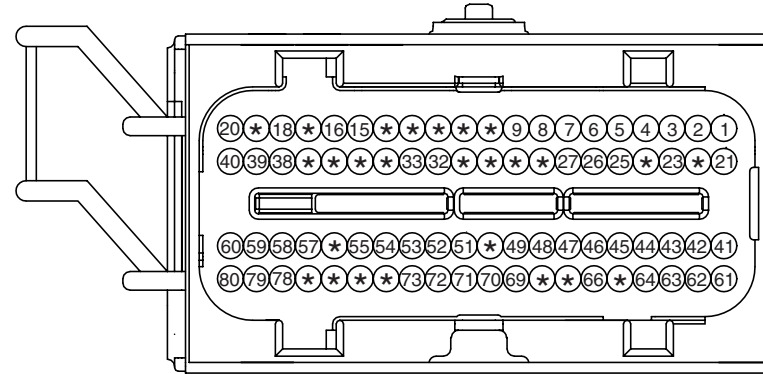

PKD\_ECU\_80F\_B\_1

**C244-K**

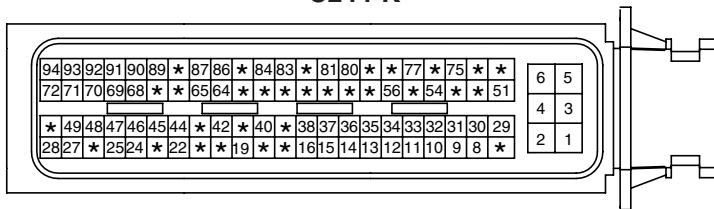

AMP\_ECU\_94F\_B

**M08**

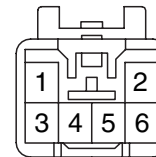

KET\_090II\_06M\_W

**M32-A**

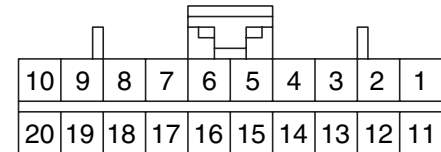

AMP\_040M2\_20F\_B

**M32-C**

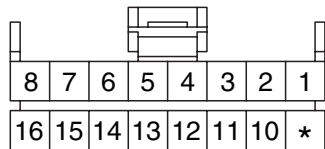

AMP\_040M1\_16F\_B

**M34**

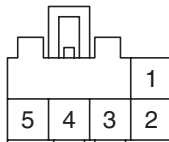

KUM\_CDR\_05F\_W

**BLANK**

**BLANK**

# BACK WARNING CONTROL SYSTEM

EA61E8AC

## BACK WARNING CONTROL SYSTEM (1)

SD957-1

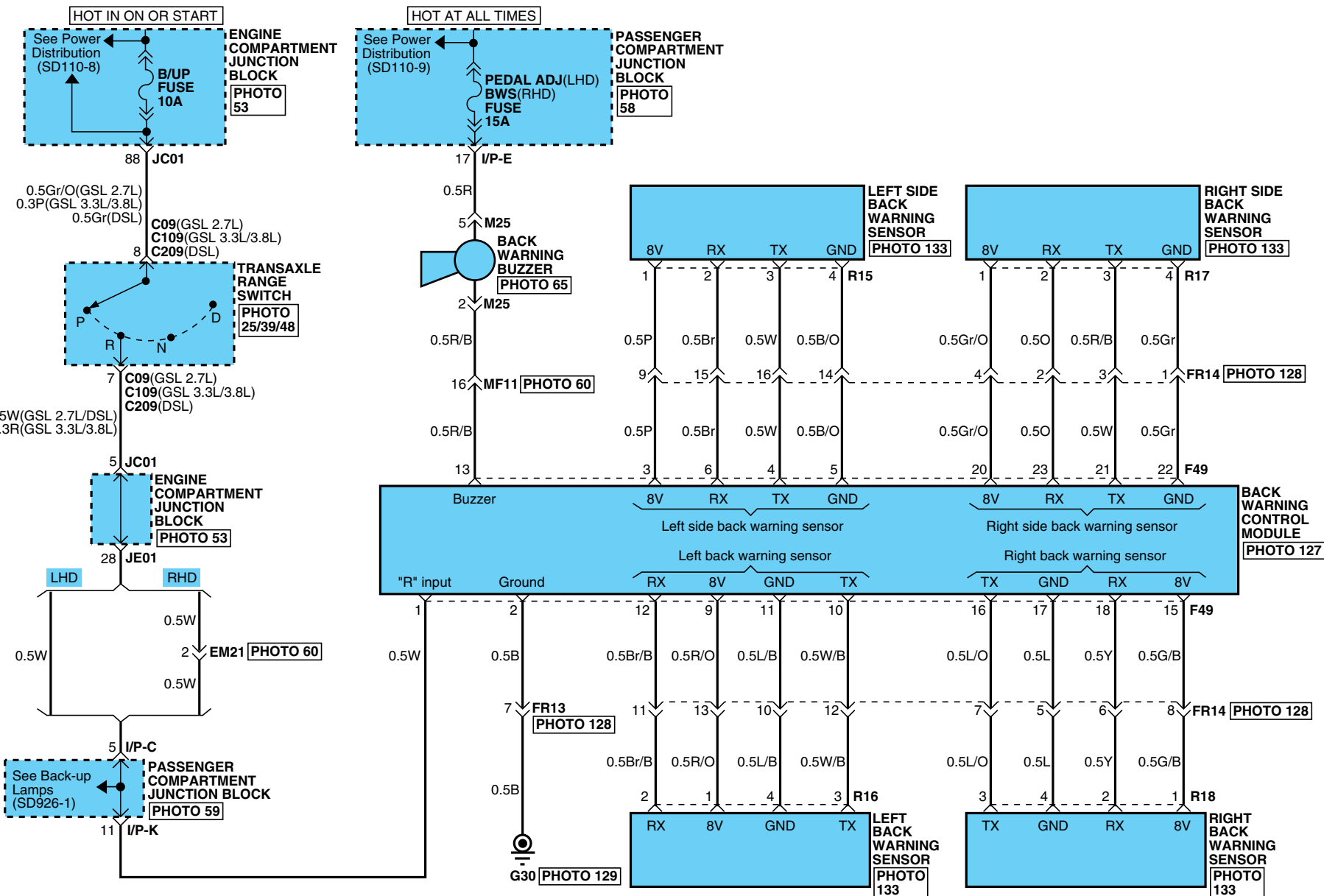

# BACK WARNING CONTROL SYSTEM

## BACK WARNING CONTROL SYSTEM (2)

SD957-2

**C09/C109/C209**



KET\_SSD\_10F\_B\_A

**F49**

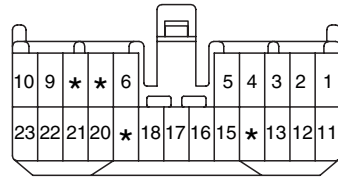

KET\_050\_23F\_W

**M25**

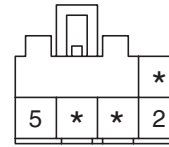

KUM\_CDR\_05F\_B

**R15**



AMP\_EJWP\_04F\_B

**R16**



AMP\_EJWP\_04F\_B

**R17**



AMP\_EJWP\_04F\_B

**R18**



AMP\_EJWP\_04F\_B

**BLANK**

AUDIO SYSTEM (1)

SD961-1

**WITH PREMIUM AMP & WITH AUTO CRUISE**

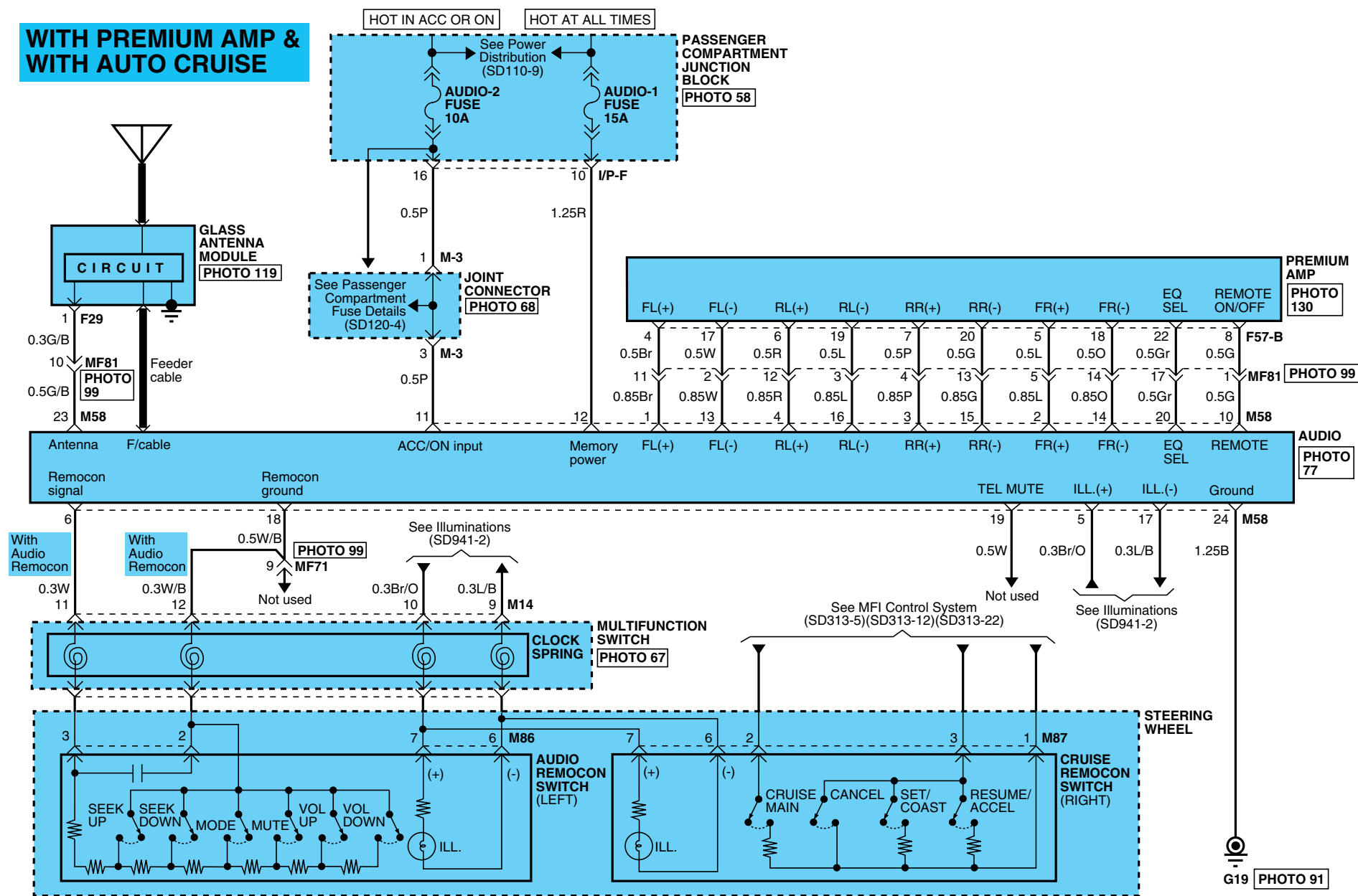

# AUDIO SYSTEM

## AUDIO SYSTEM (2)

SD961-2

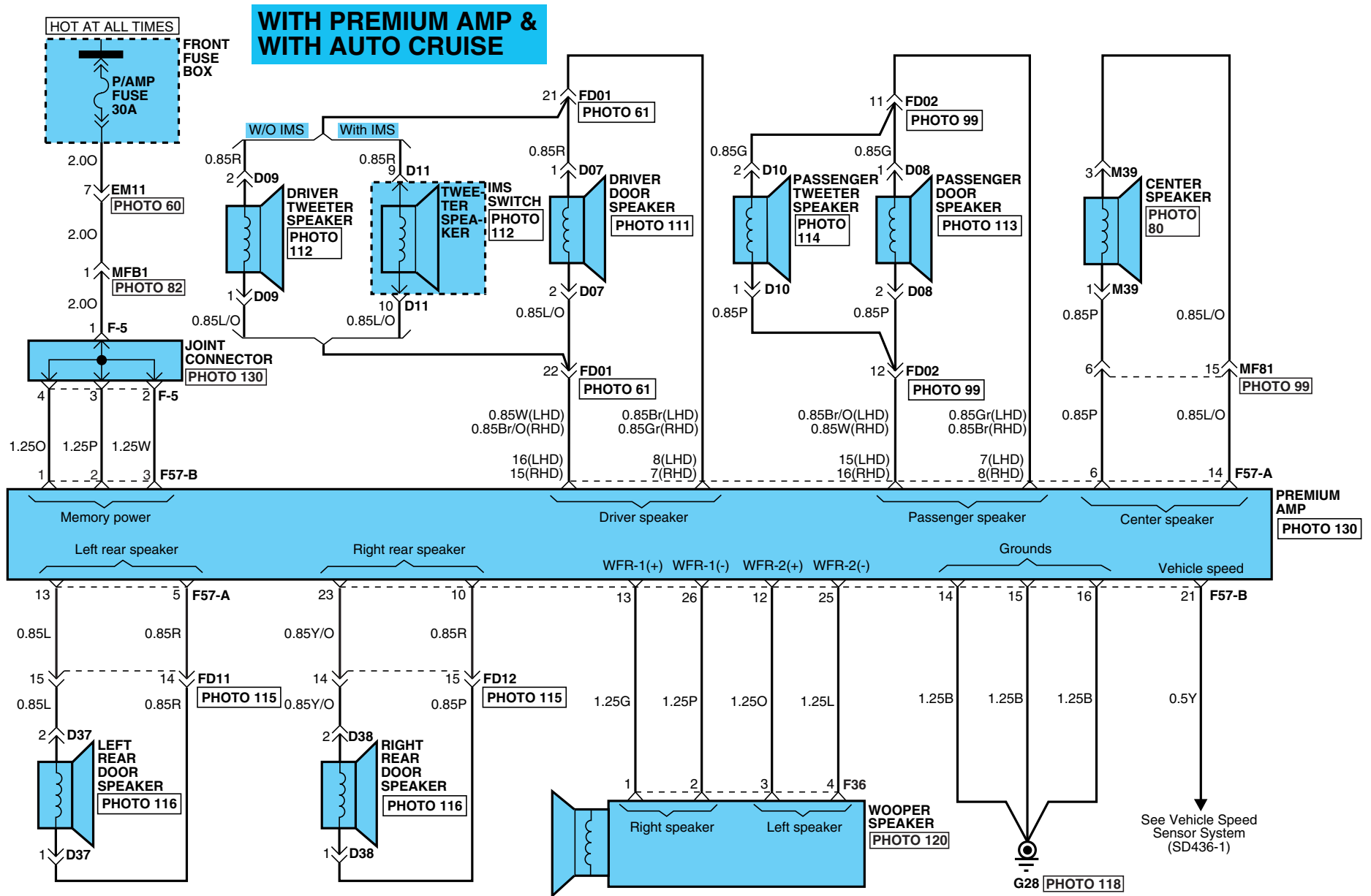

# AUDIO SYSTEM

## AUDIO SYSTEM (3)

SD961-3

**WITH PREMIUM AMP & W/O AUTO CRUISE**

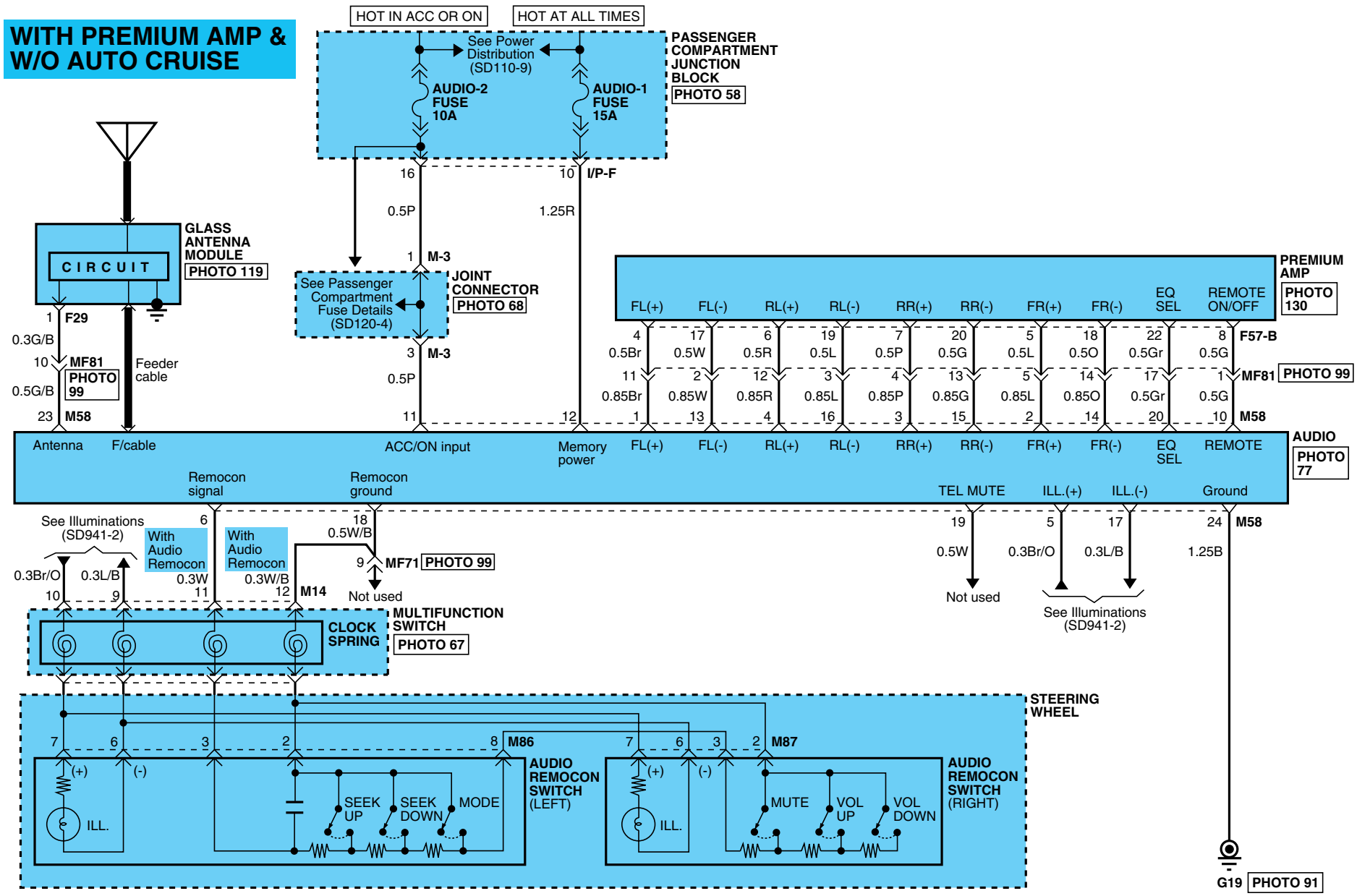



# AUDIO SYSTEM

## AUDIO SYSTEM (4)

SD961-4

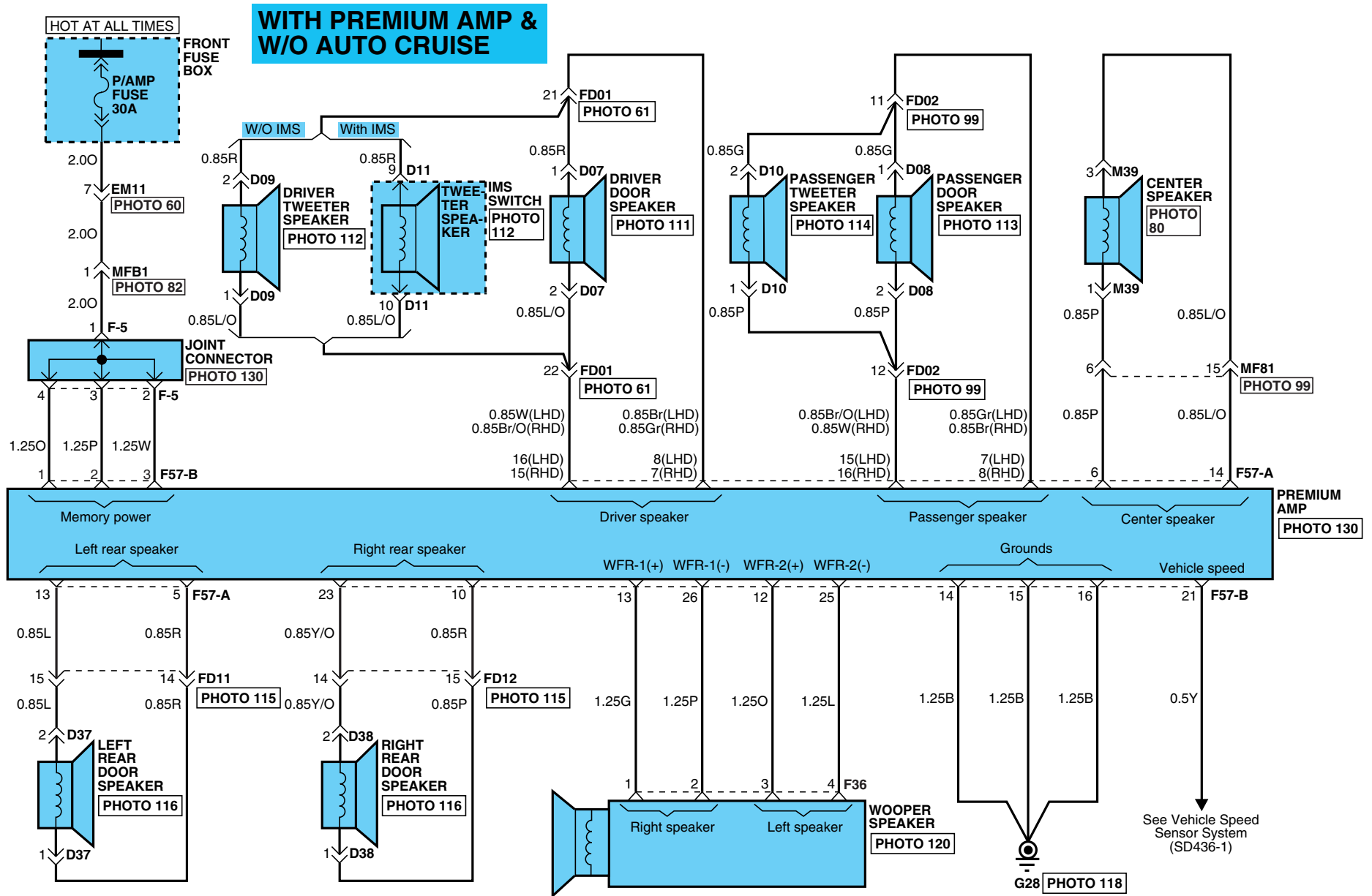

# AUDIO SYSTEM

## AUDIO SYSTEM (5)

SD961-5

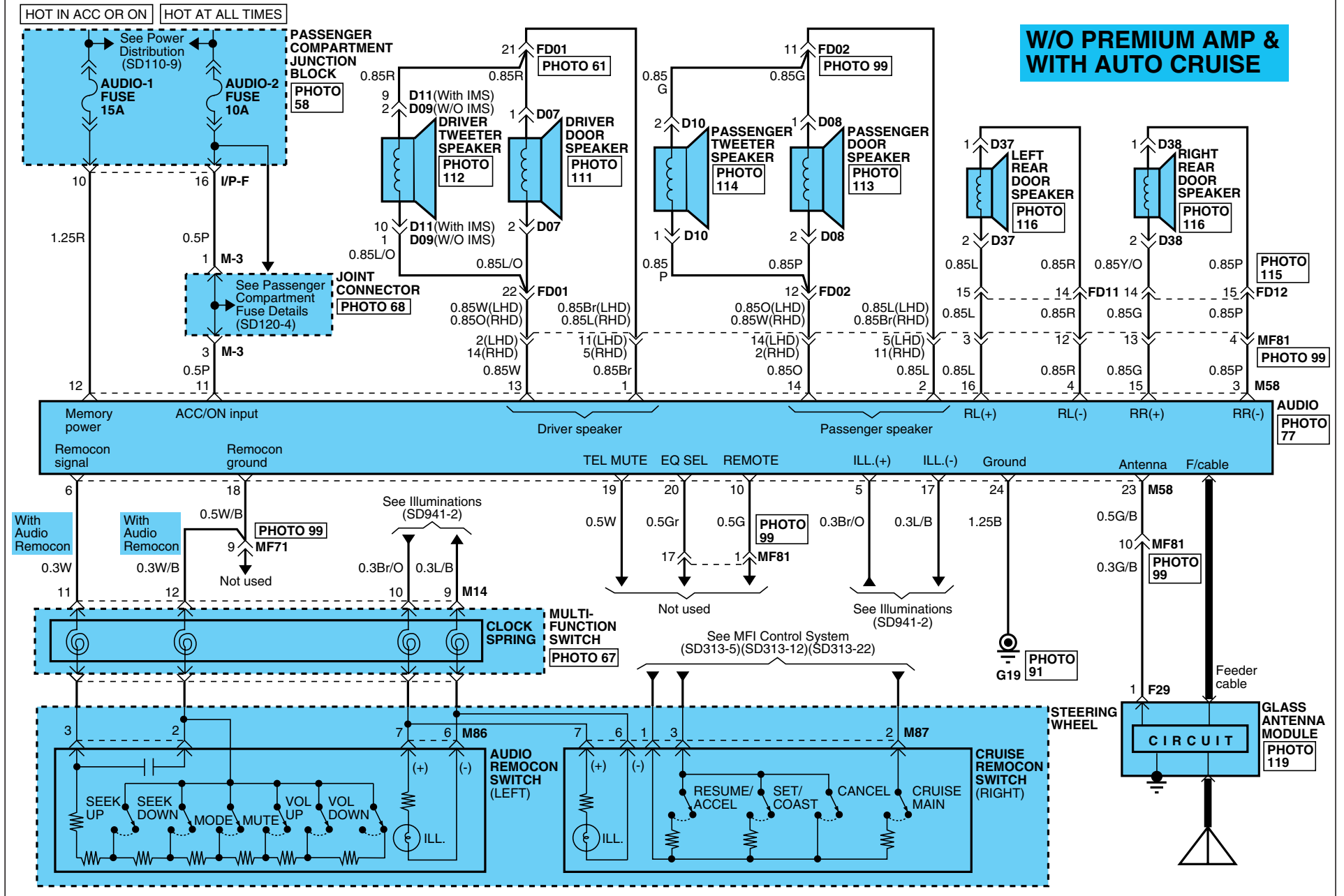

# AUDIO SYSTEM

## AUDIO SYSTEM (6)

SD961-6

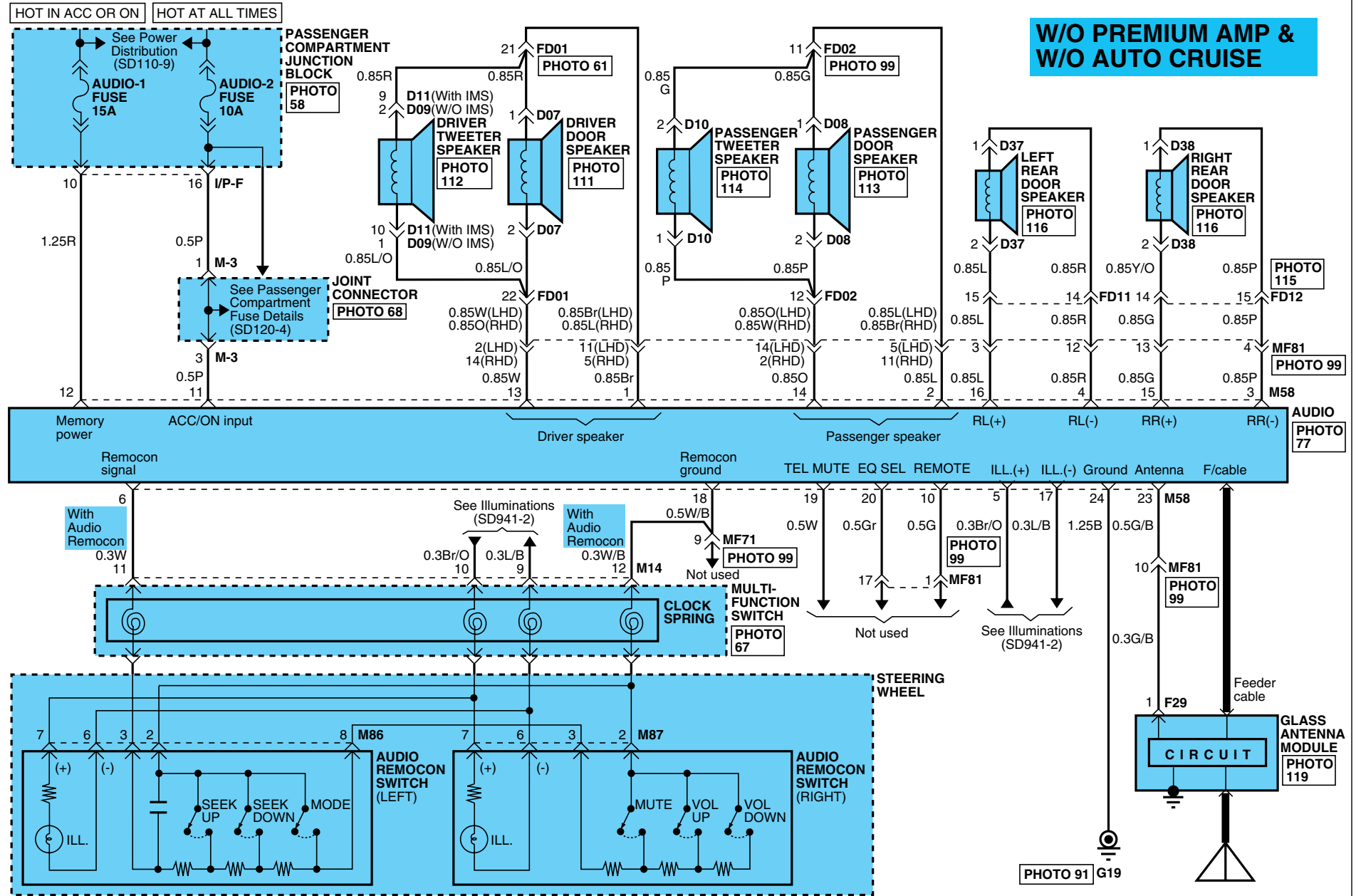

**W/O PREMIUM AMP & W/O AUTO CRUISE**



**AUDIO SYSTEM**

**AUDIO SYSTEM (7)**

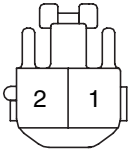
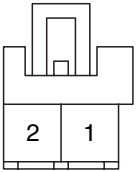
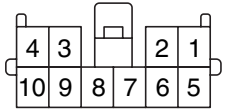
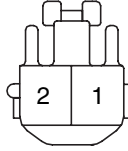
**SD961-7**

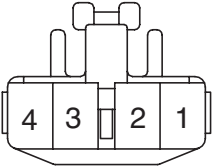
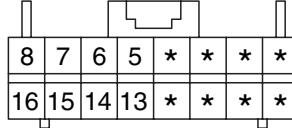
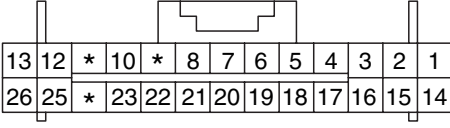
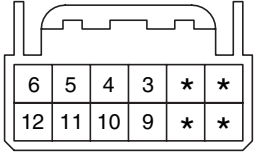
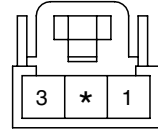
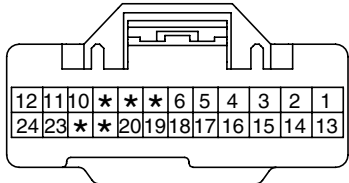
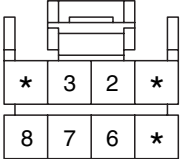
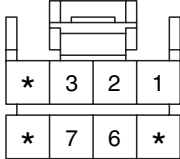
<p><b>D07/D08</b></p>  <p>KET_090III_02F_W_L</p>	<p><b>D09/D10</b></p>  <p>KUM_CDR_02F_W</p>	<p><b>D11</b></p>  <p>KET_070_10F_W</p>	<p><b>D37/D38</b></p>  <p>KET_090III_02F_W_L</p>
<p><b>F29</b></p>  <p>AMP_PLM2_01F_B_187</p>	<p><b>F36</b></p>  <p>KET_090III_04F_W</p>	<p><b>F57-A</b></p>  <p>AMP_0407_MKII_16F_D_GR</p>	<p><b>F57-B</b></p>  <p>AMP_0407_MKII_26F_D_GR</p>
<p><b>BLANK</b></p>	<p><b>M14</b></p>  <p>AMP_025_12F_W</p>	<p><b>M39</b></p>  <p>AMP_070_03F_W_HOR</p>	<p><b>M58</b></p>  <p>KET_0409_24F_W</p>
<p><b>M86</b></p>  <p>AMP_040M1_08F_B</p>	<p><b>M87</b></p>  <p>AMP_040M1_08F_B</p>	<p><b>BLANK</b></p>	<p><b>BLANK</b></p>
<p><b>BLANK</b></p>			

**AUDIO SYSTEM**

**AUDIO SYSTEM (8)**

**SD961-8**

**MEMO**

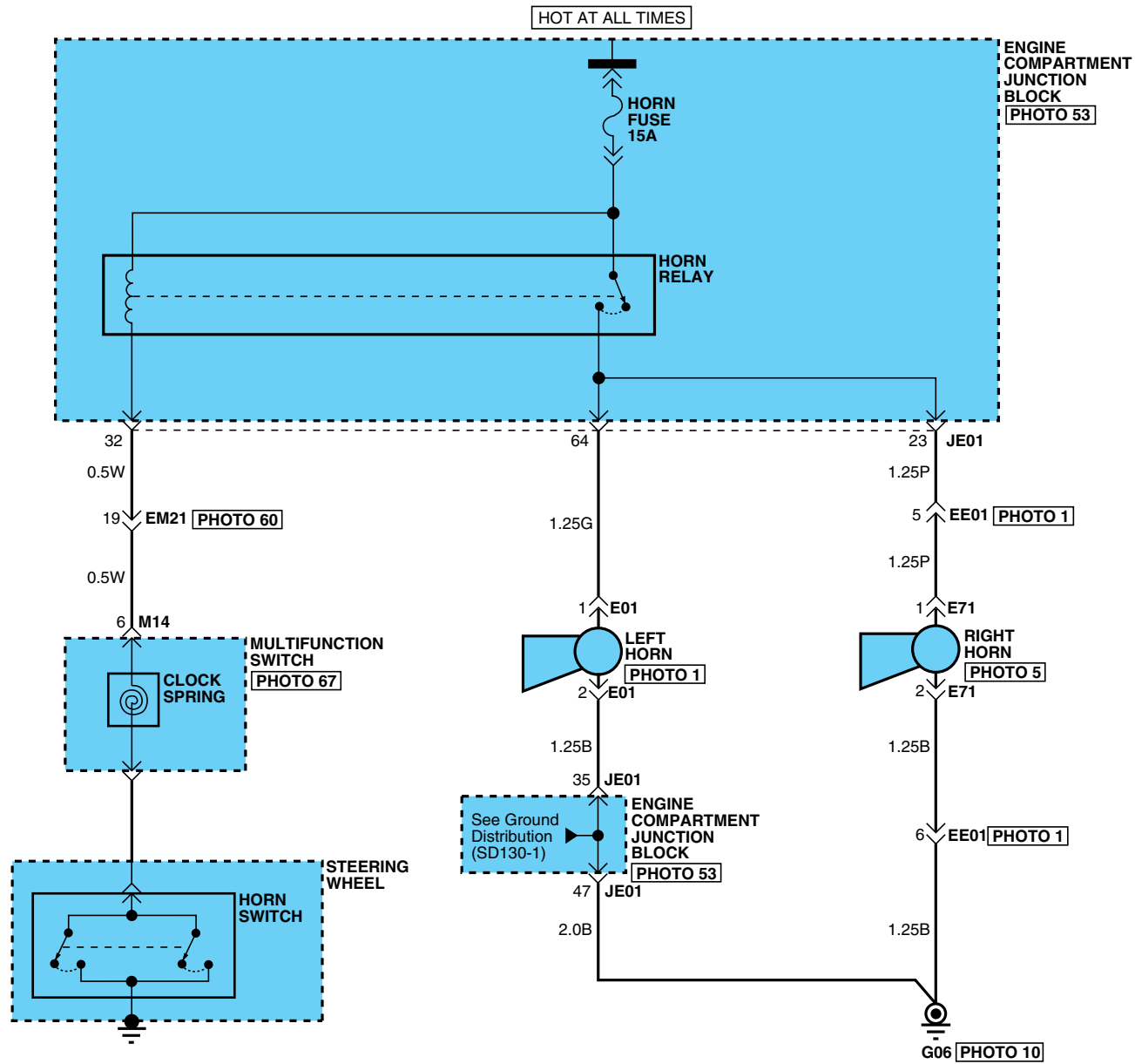

# HORNS

HORNS (2)

SD968-2

E01

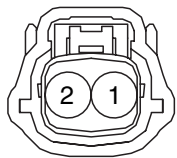

MLX\_HORN\_02F\_B\_FILT

E71

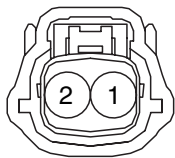

MLX\_HORN\_02F\_B\_FILT

M14

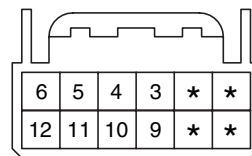

AMP\_025\_12F\_W

BLANK

**BLOWER & A/C CONTROLS (AUTO) (1)**

**SD971-1**

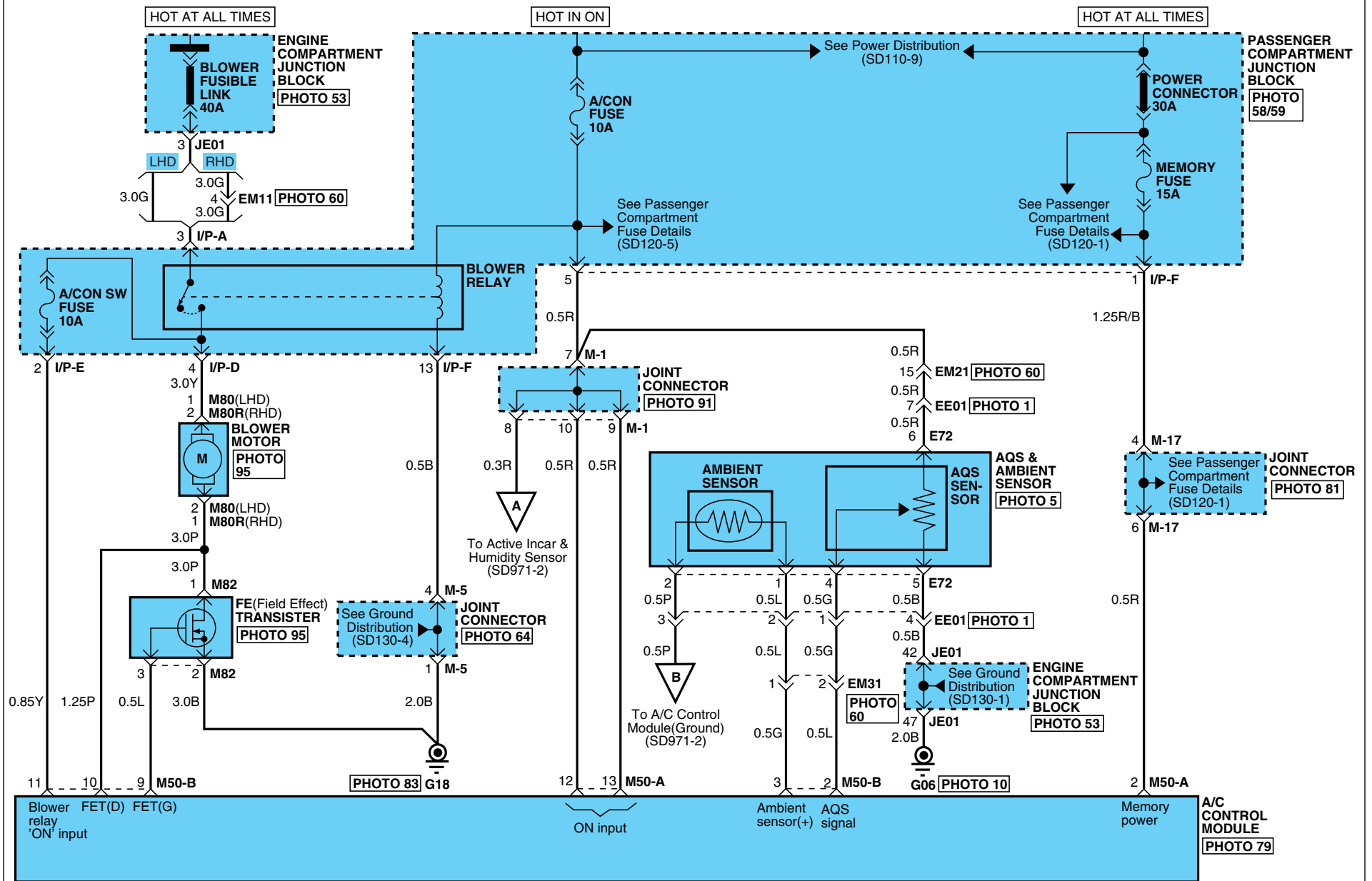





# BLOWER & A/C CONTROLS

## BLOWER & A/C CONTROLS (AUTO) (3)

SD971-3

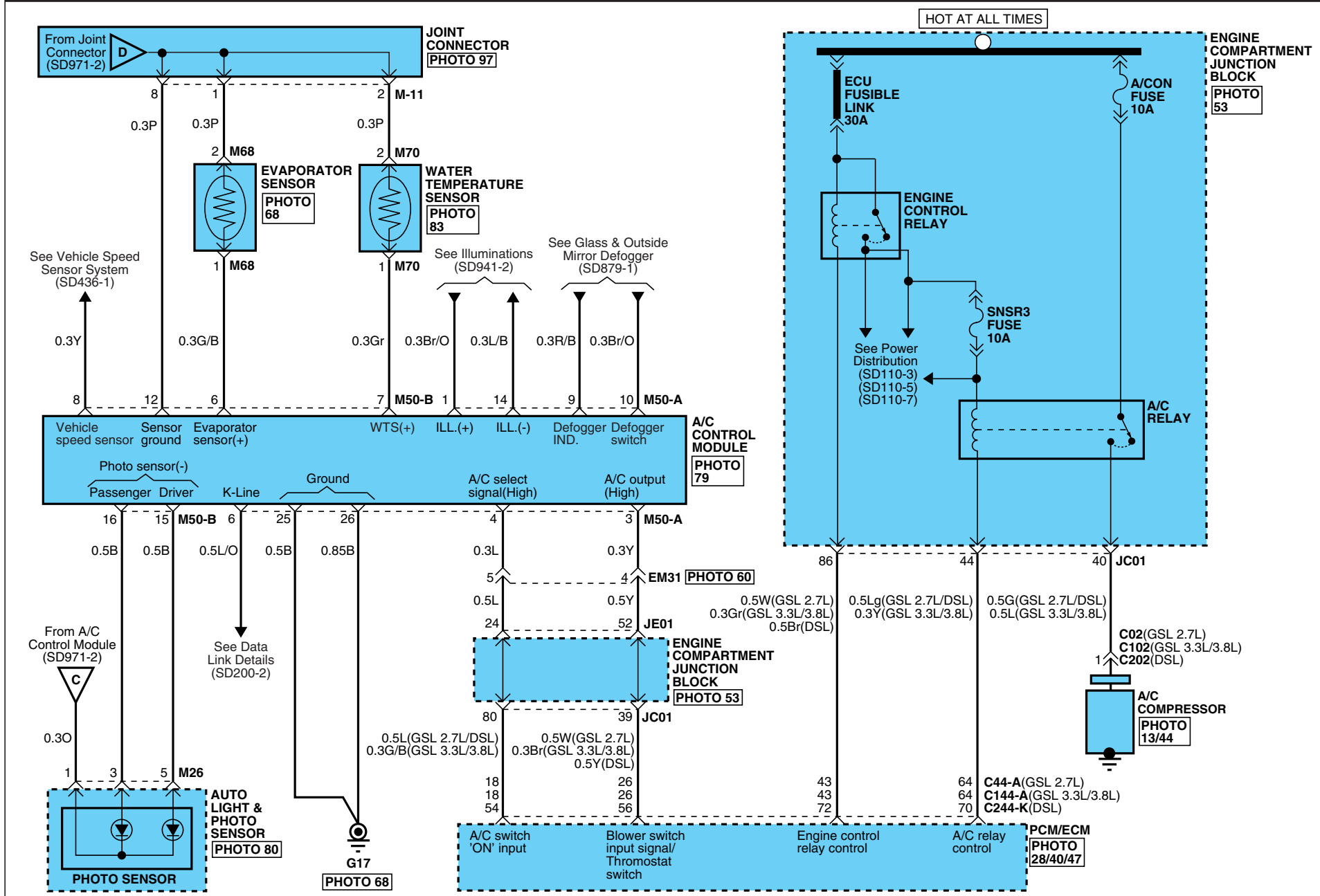

# BLOWER & A/C CONTROLS

## BLOWER & A/C CONTROLS (AUTO) (4)

SD971-4

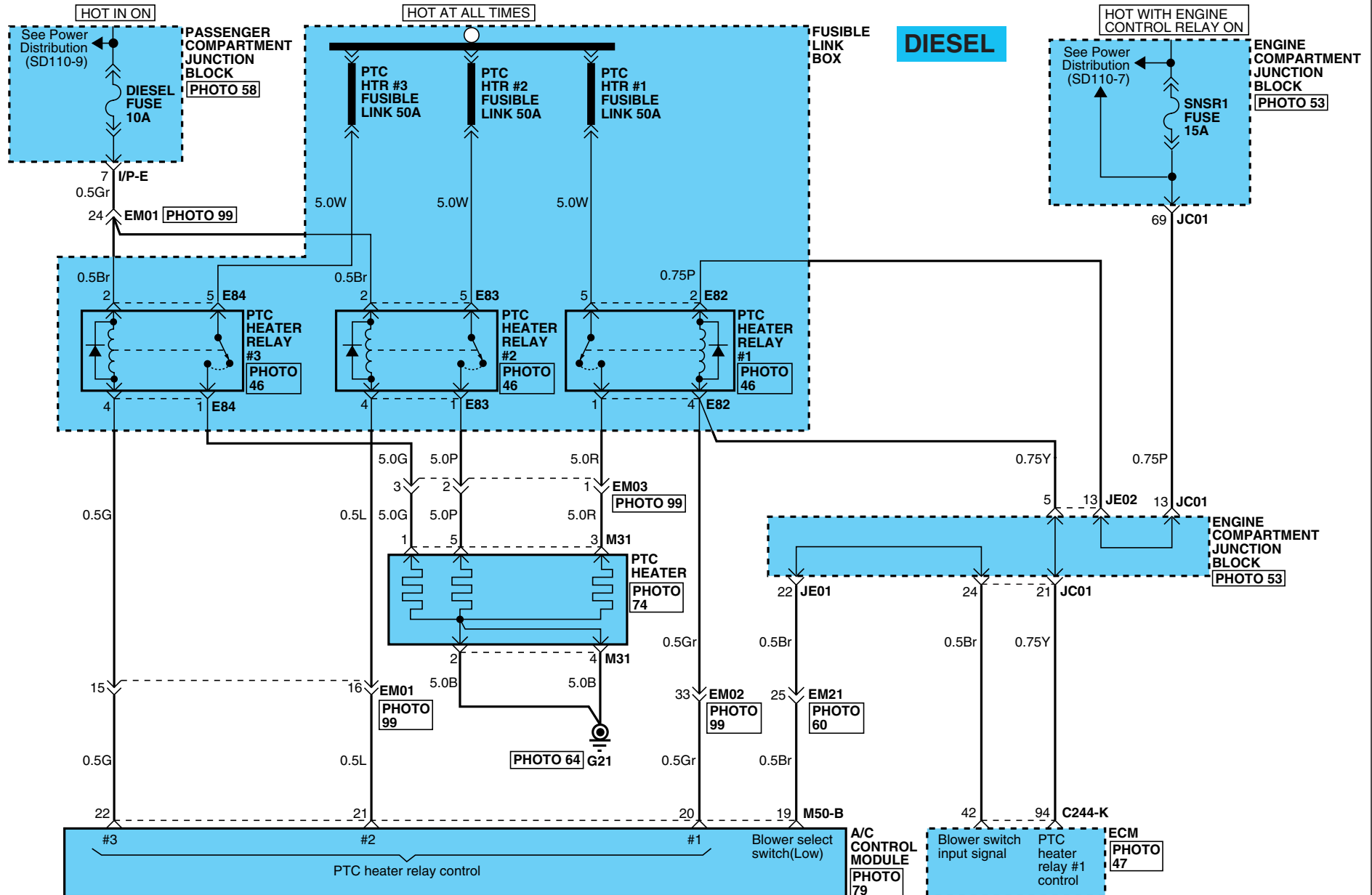

\* P.T.C (Positive Temperature Coefficient)

**BLOWER & A/C CONTROLS**

**BLOWER & A/C CONTROLS (AUTO) (5)**

**SD971-5**

**C44-A**

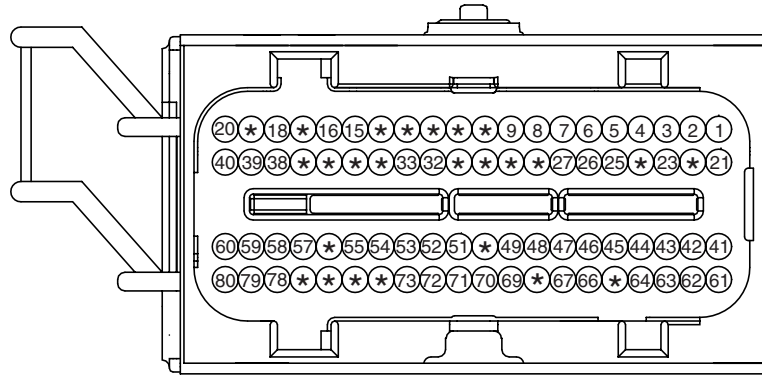

PKD\_ECU\_80F\_Gr\_1

**C144-A**

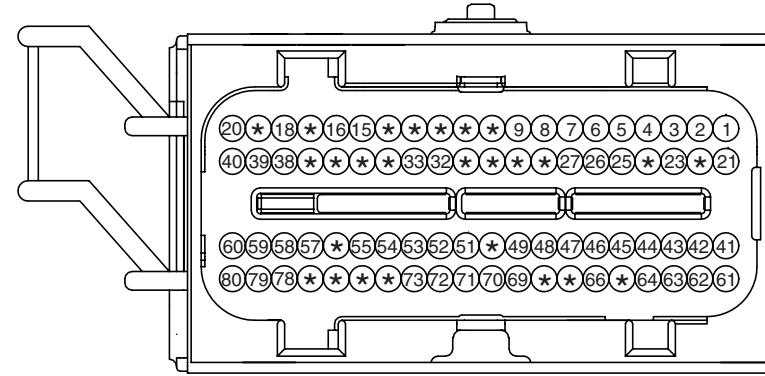

PKD\_ECU\_80F\_B\_1

**C244-K**

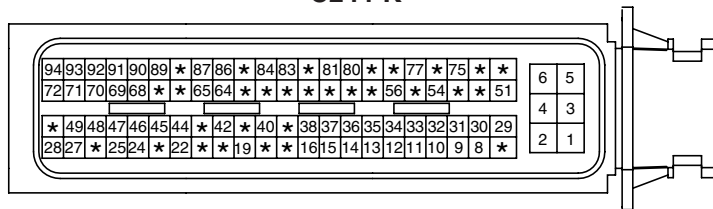

AMP\_ECU\_94F\_B

**C02/C102/C202**



KUM\_NMWP\_01F\_B

**BLANK**

**E72**



KET\_090IWP\_06F\_B

**E82**

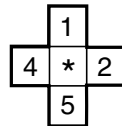

**E83**

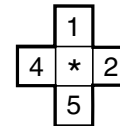

**E84**

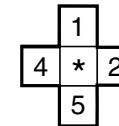

**M26**

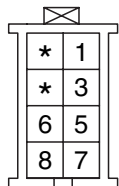

KET\_030\_08F\_GR

**M31**

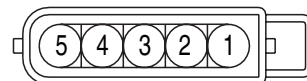

AMP\_375\_05F\_B

**M42/M42R**

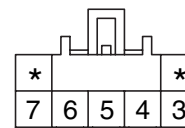

KUM\_CDR\_07F\_B

**M43/M43R**

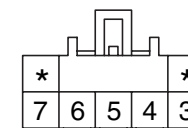

KUM\_CDR\_07F\_L

**BLOWER & A/C CONTROLS**

**BLOWER & A/C CONTROLS (AUTO) (6)**

**SD971-6**

**M50-A**

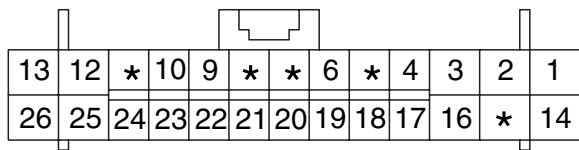

AMP\_0407\_26F\_W\_HD

**M50-B**

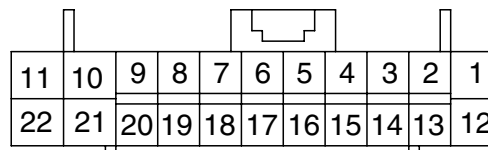

AMP\_0407\_22F\_W\_HD

**M62/M62R**

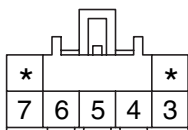

KUM\_CDR\_07F\_W

**M63/M63R**

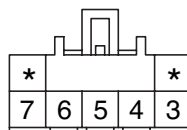

KUM\_CDR\_07F\_L

**M67**

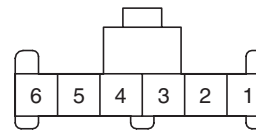

KET\_91A\_06F\_W

**M68**

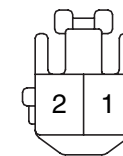

KET\_090III\_02F\_W\_L

**M70**



KET\_090II\_02F\_W\_SPK

**M80/M80R**

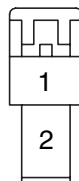

KUM\_DSD\_02F\_W

**M82**

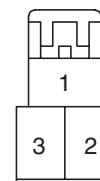

KUM\_DSD\_03F\_B

**BLANK**

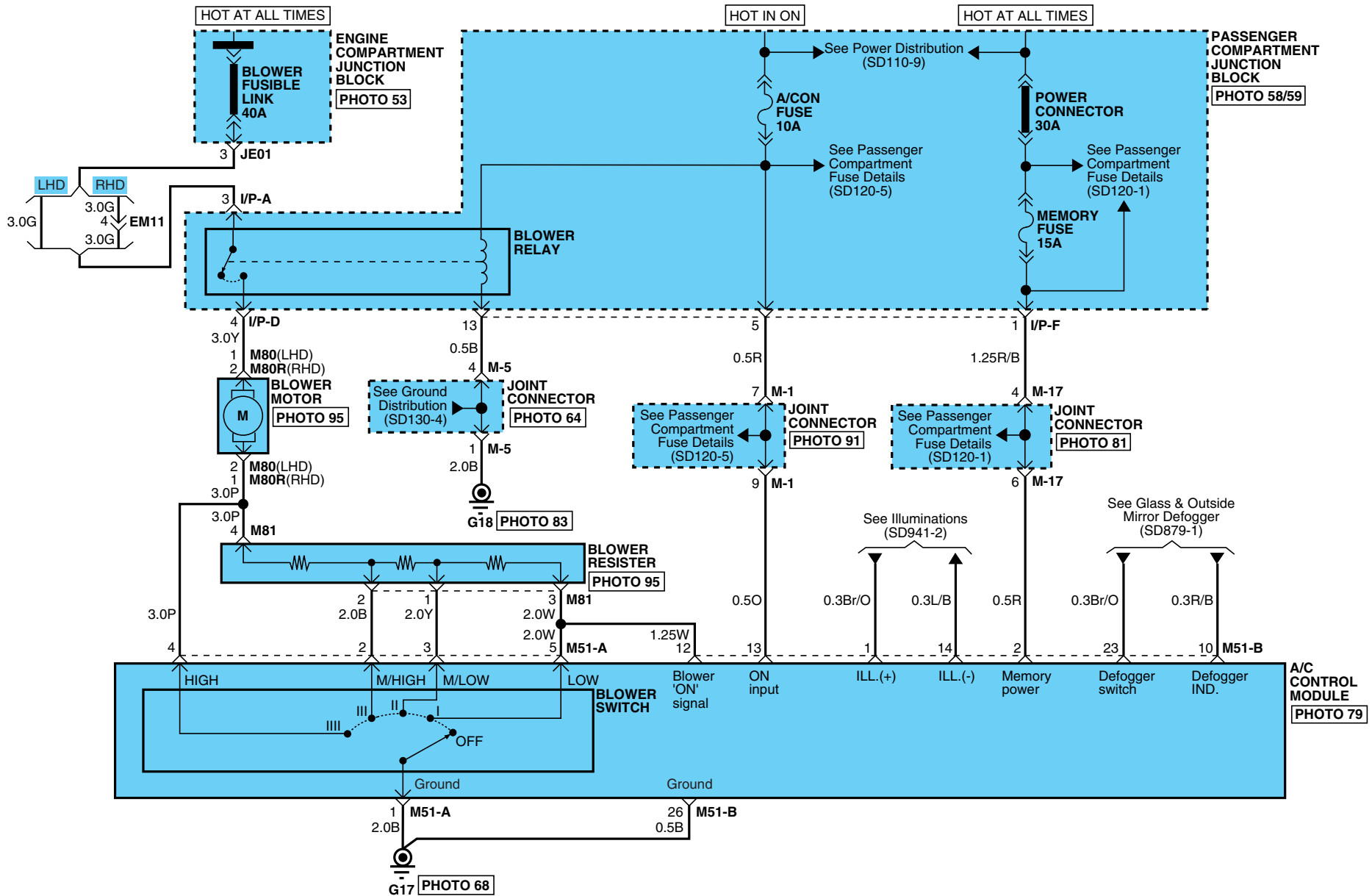



# BLOWER & A/C CONTROLS

## BLOWER & A/C CONTROLS (MANUAL) (3)

SD971-9

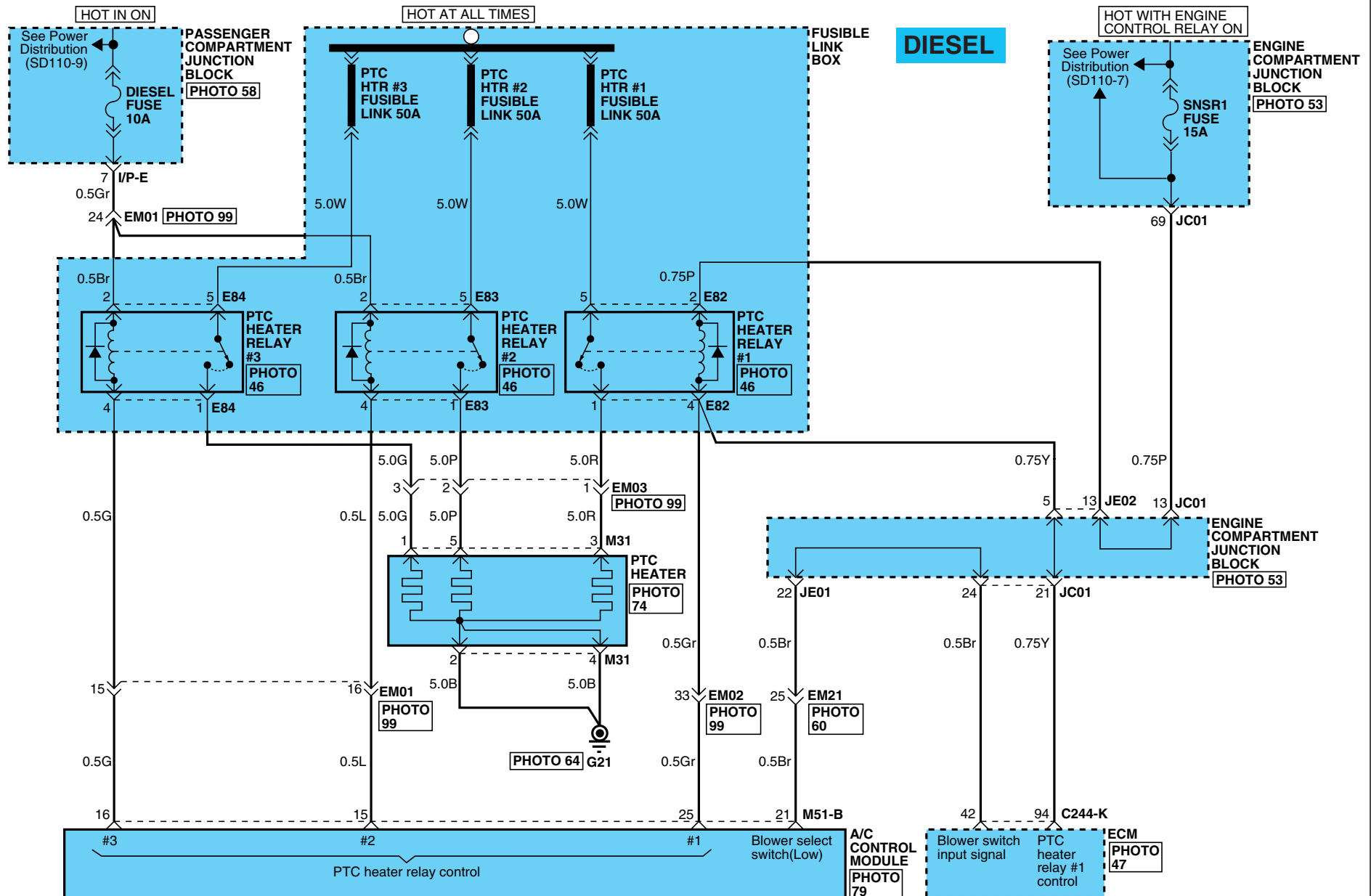

\* P.T.C (Positive Temperature Coefficient)



# BLOWER & A/C CONTROLS

## BLOWER & A/C CONTROLS (MANUAL) (4)

SD971-10

C44-A

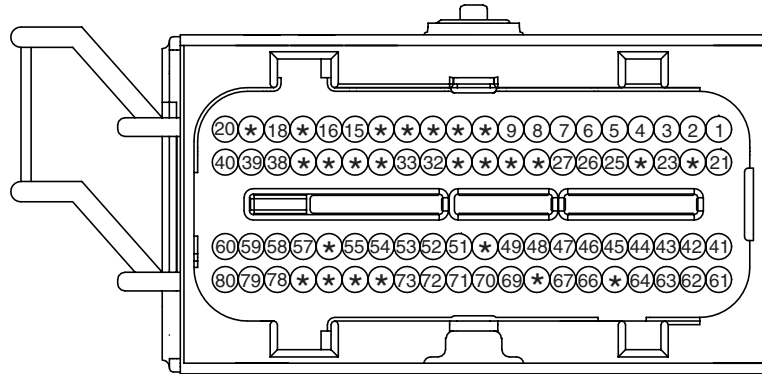

PKD\_ECU\_80F\_Gr\_1

C244-K

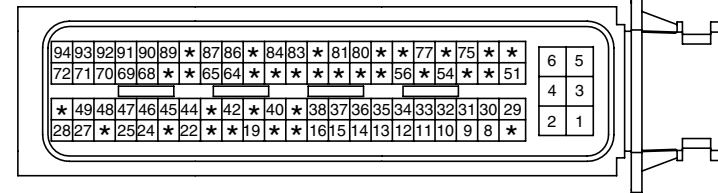

AMP\_ECU\_94F\_B

C02/C102/C202



KUM\_NMWP\_01F\_B

E82

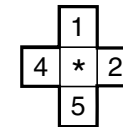

E83

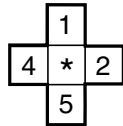

E83

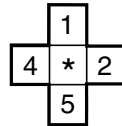

M31

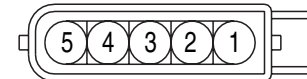

AMP\_375\_05F\_B

M43/M43R

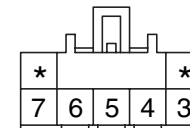

KUM\_CDR\_07F\_L

M51-A

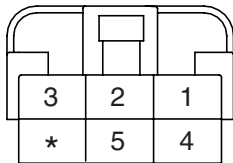

KET\_250DL\_06F\_W

M51-B

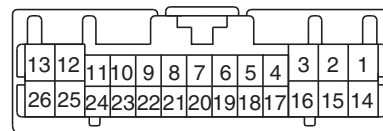

KET\_0407\_26F\_W

M62/M62R

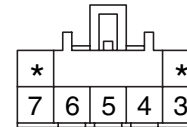

KUM\_CDR\_07F\_W

M63/M63R

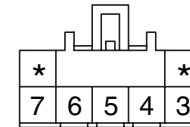

KUM\_CDR\_07F\_B

M68

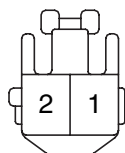

KET\_090III\_02F\_W\_L

M80/M80R



KUM\_DSD\_02F\_W

M81

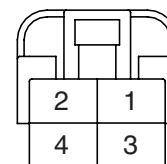

KET\_250DL\_04F\_W

BLANK

WIPER & WASHER (1)

SD981-1

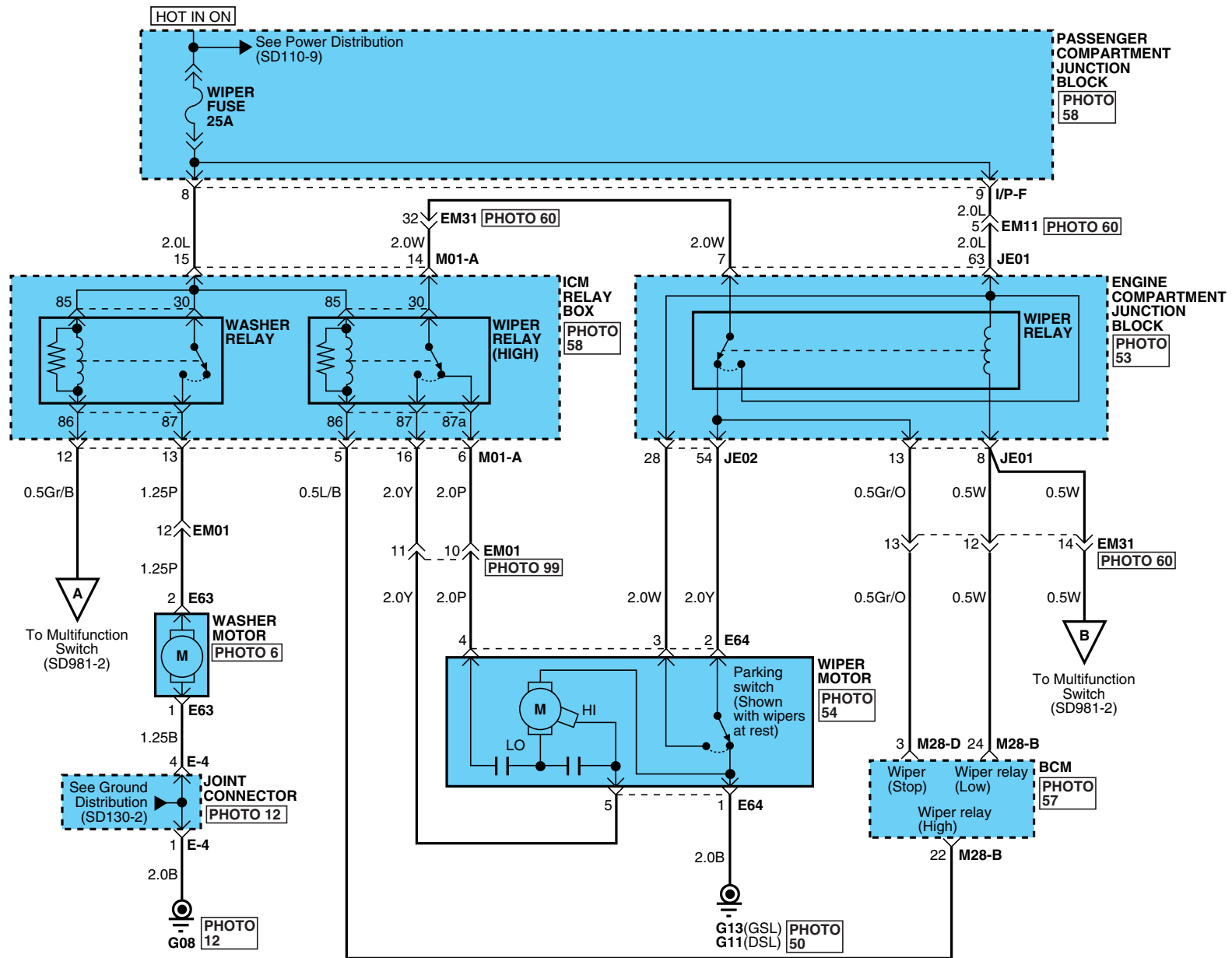

# WIPER & WASHER

## WIPER & WASHER (2)

SD981-2

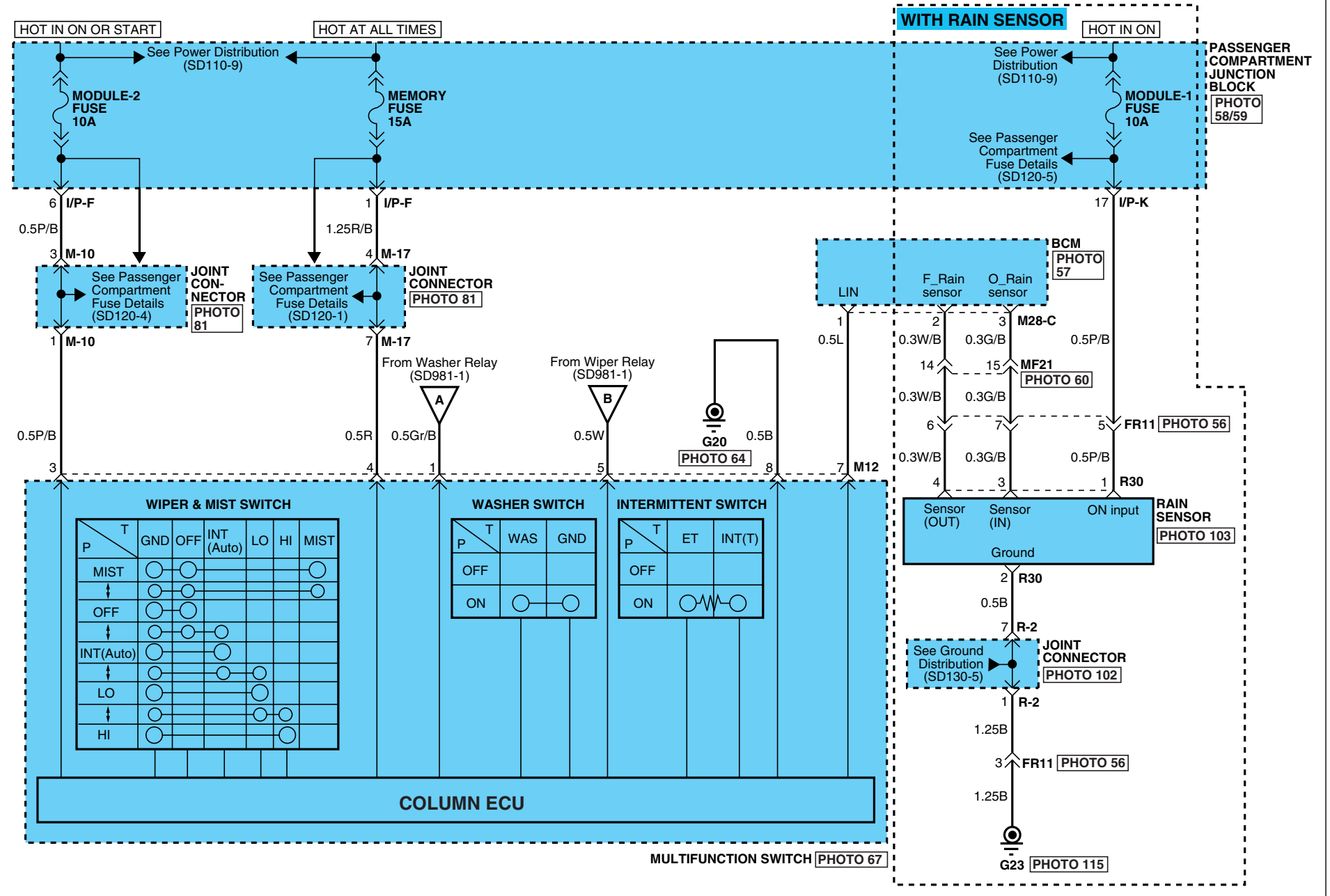

# WIPER & WASHER

## WIPER & WASHER (3)

SD981-3

**E63**

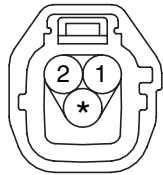

KET\_090IWP\_03F\_B

**E64**

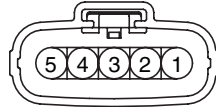

KUM\_NDWP\_05F\_B

**M01-A**

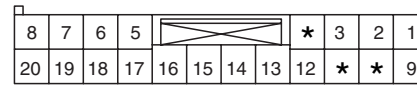

AMP\_0925\_20F\_W

**M12**

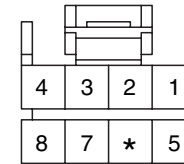

AMP\_040M1\_08F\_B

**M28-B**

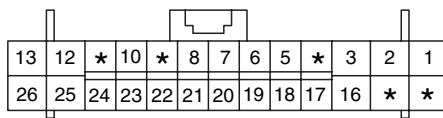

AMP\_0407\_26F\_W\_HD

**M28-C**

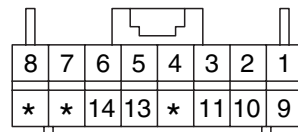

AMP\_0407\_16F\_W\_040

**M28-D**

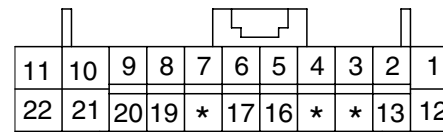

AMP\_0407\_22F\_W\_HD

**R30**

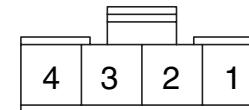

MLX\_FIT\_04F\_B

COMPONENT LOCATIONS (1)

PHOTO.1

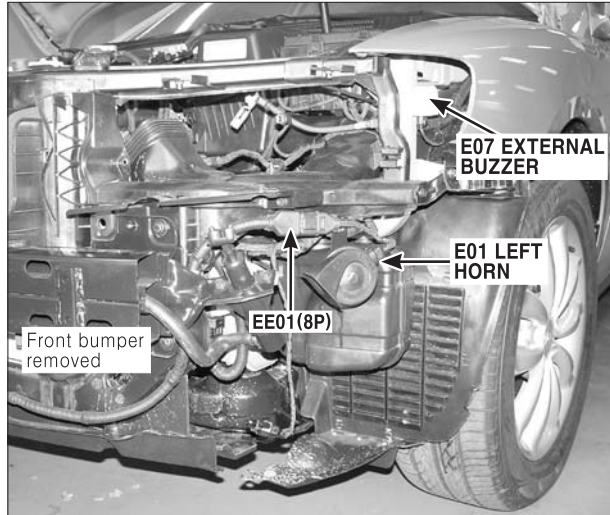

PHOTO.2

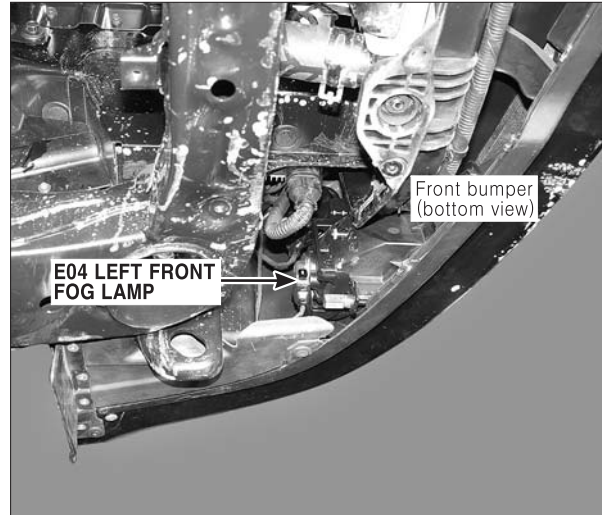

PHOTO.3

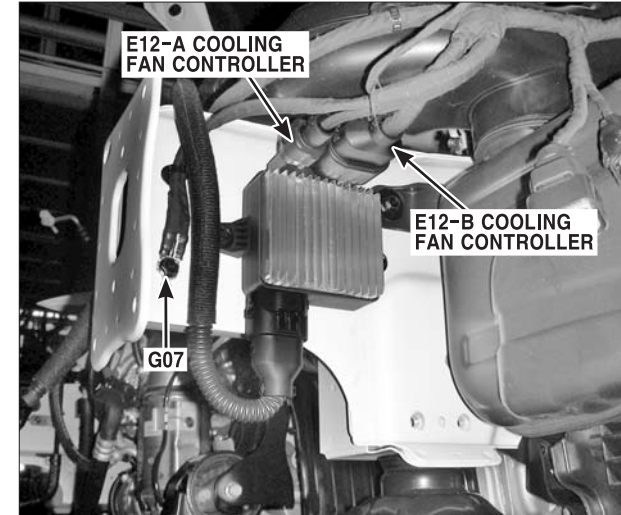

PHOTO.4

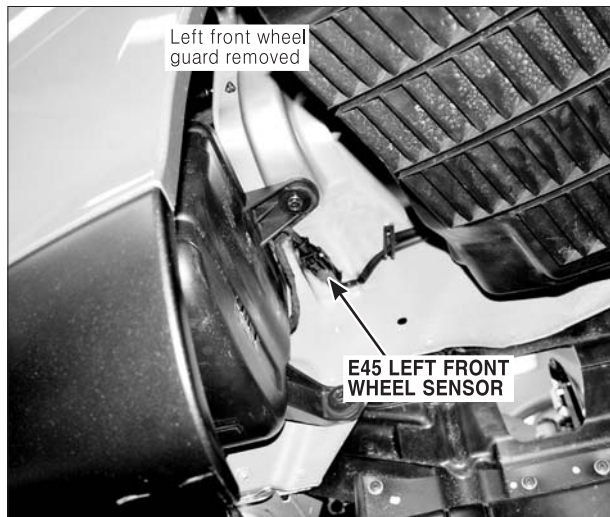

PHOTO.5

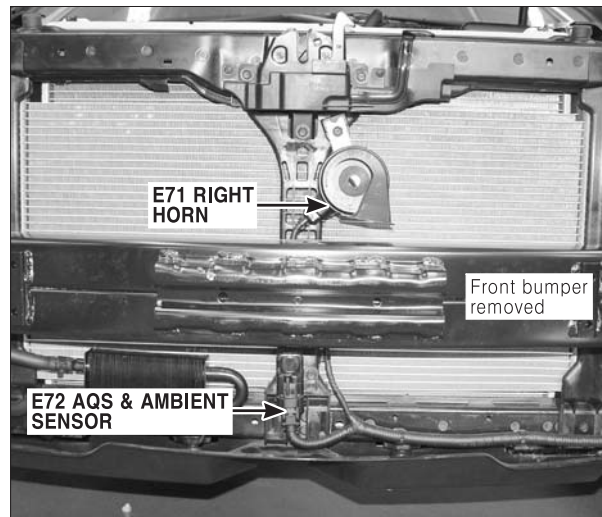
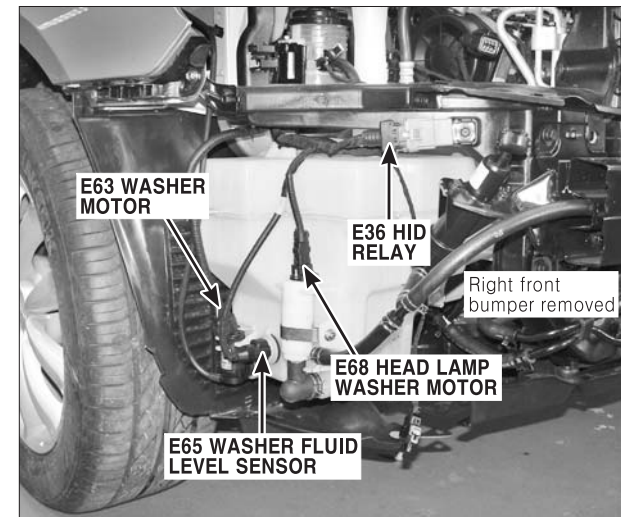

PHOTO.6



# COMPONENT LOCATIONS

## COMPONENT LOCATIONS (2)

CL-2

PHOTO.7

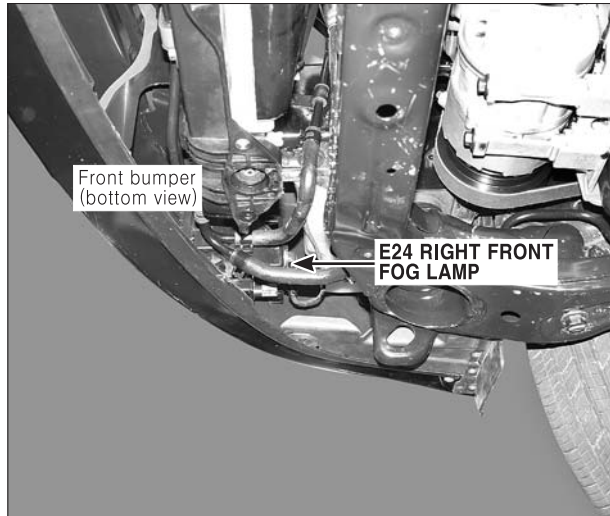

PHOTO.8



PHOTO.9

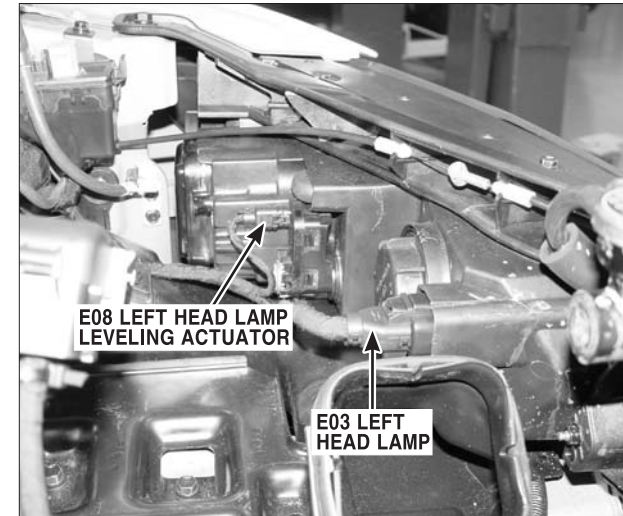

PHOTO.10

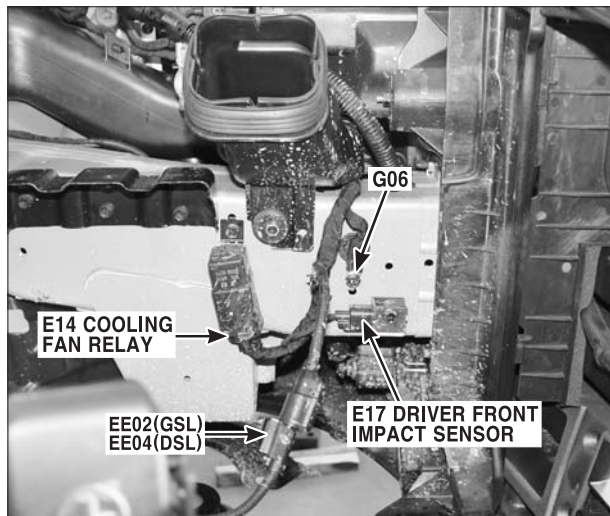

PHOTO.11

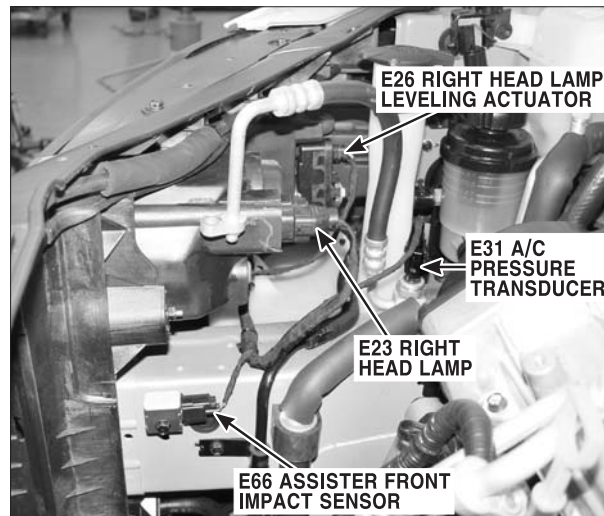
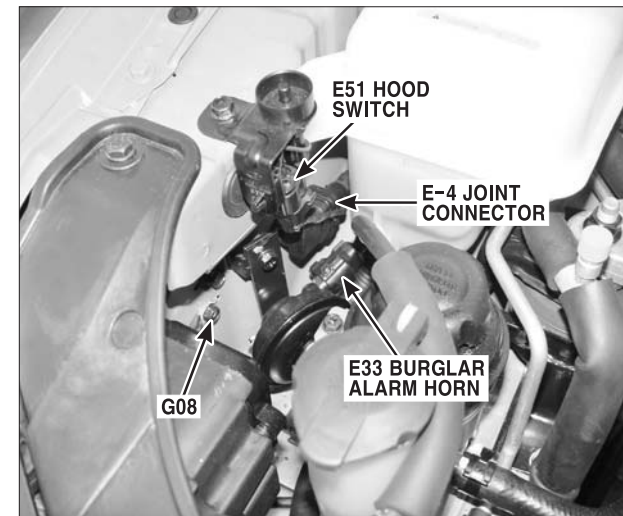

PHOTO.12



# COMPONENT LOCATIONS

## COMPONENT LOCATIONS (3)

CL-3

PHOTO.13

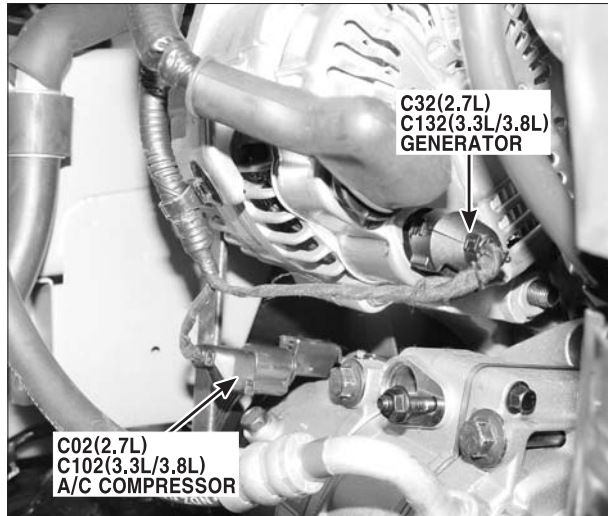

PHOTO.14



PHOTO.15

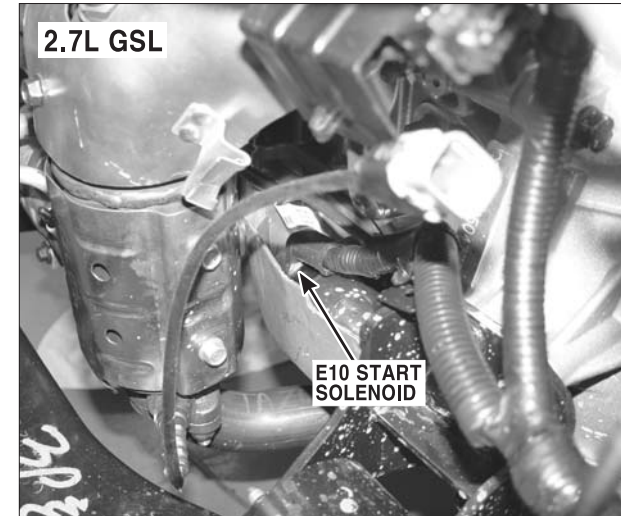

PHOTO.16

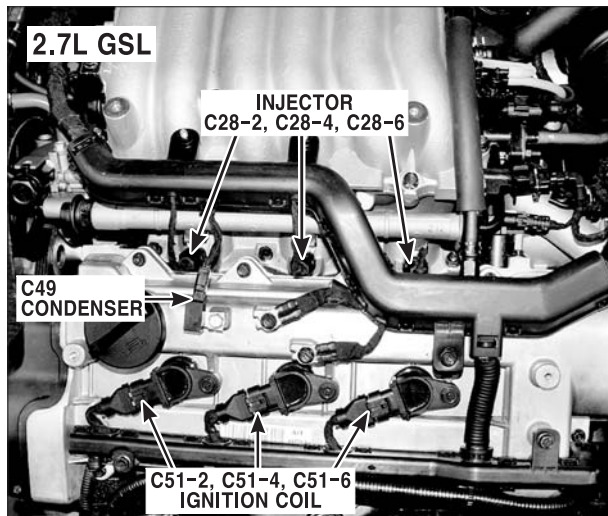

PHOTO.17

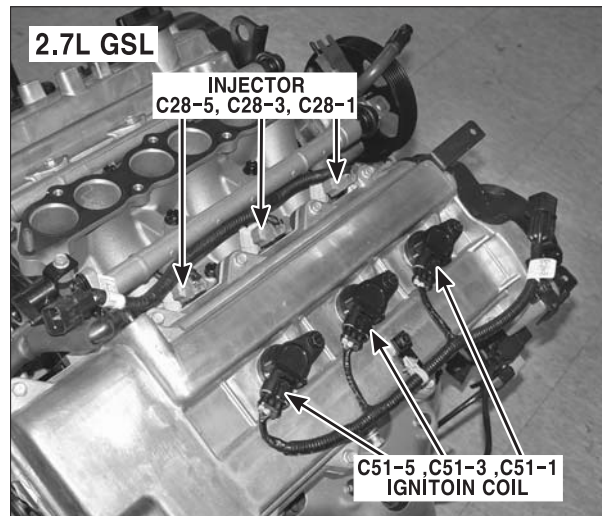
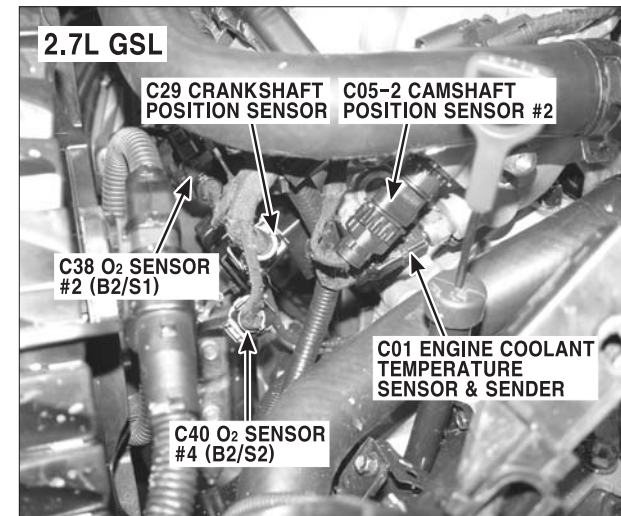

PHOTO.18



# COMPONENT LOCATIONS

## COMPONENT LOCATIONS (4)

CL-4

PHOTO.19

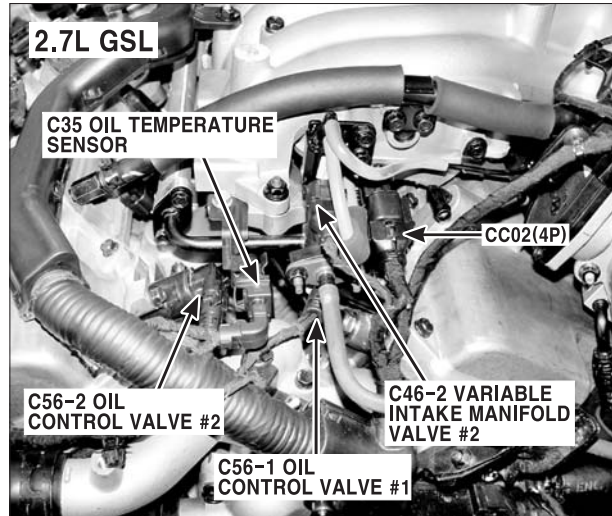

PHOTO.20

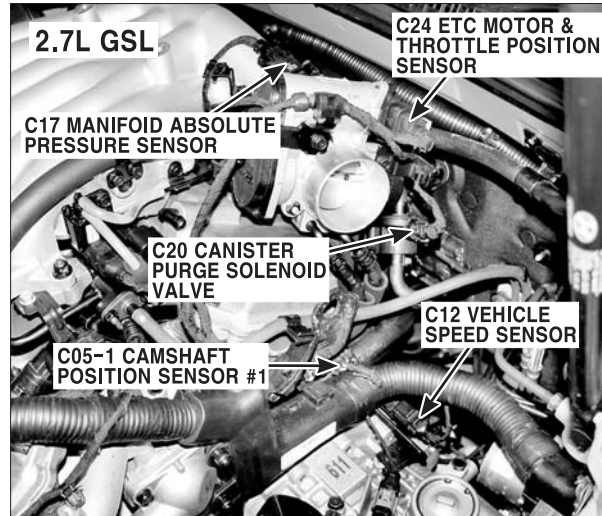

PHOTO.21

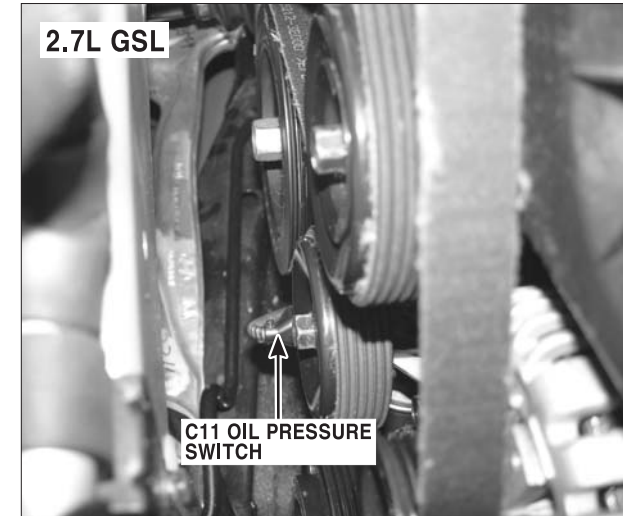

PHOTO.22

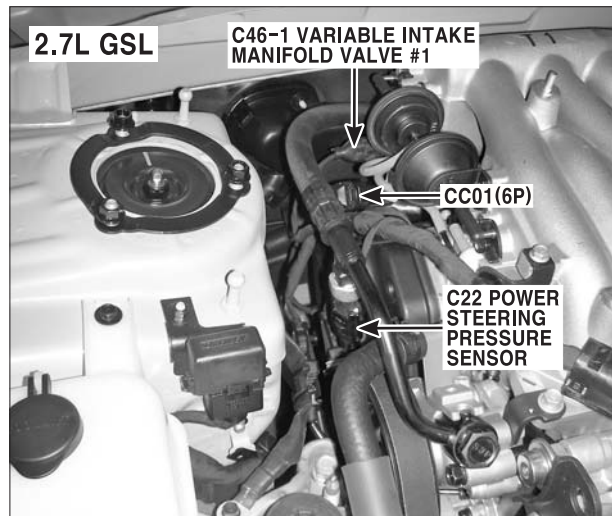

PHOTO.23

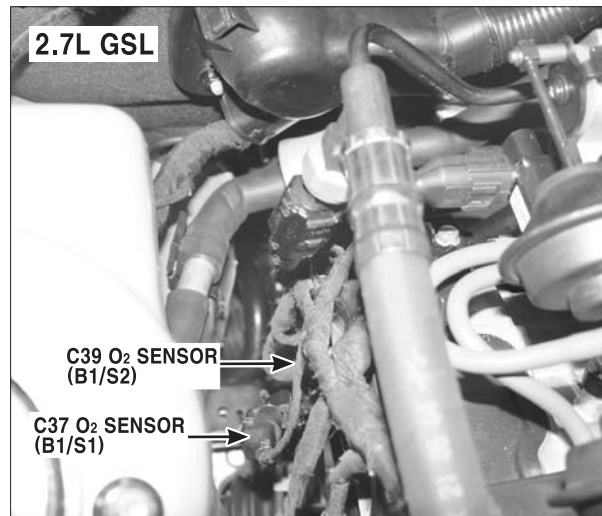
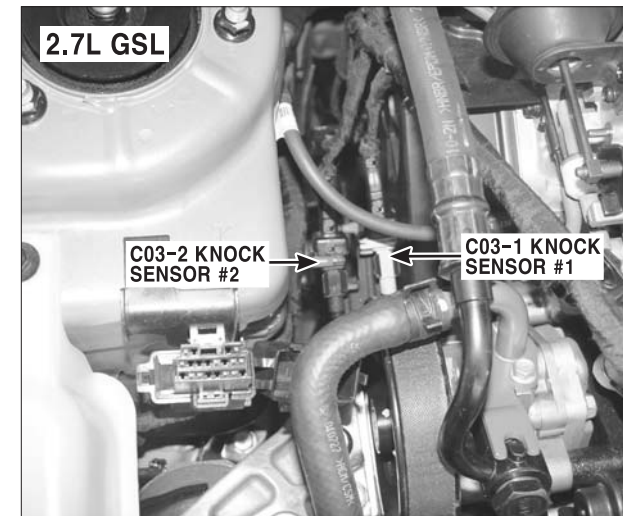

PHOTO.24





# COMPONENT LOCATIONS

## COMPONENT LOCATIONS (5)

CL-5

PHOTO.25

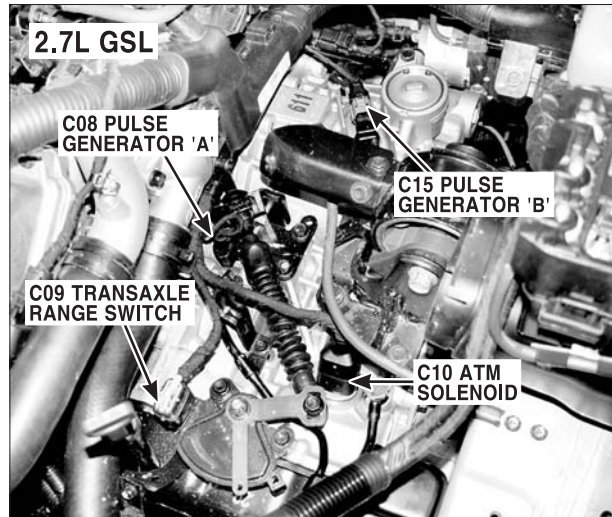

PHOTO.26



PHOTO.27



PHOTO.28



PHOTO.29

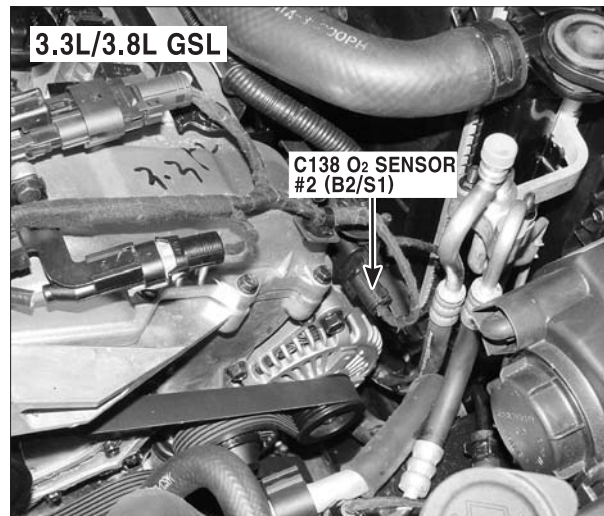
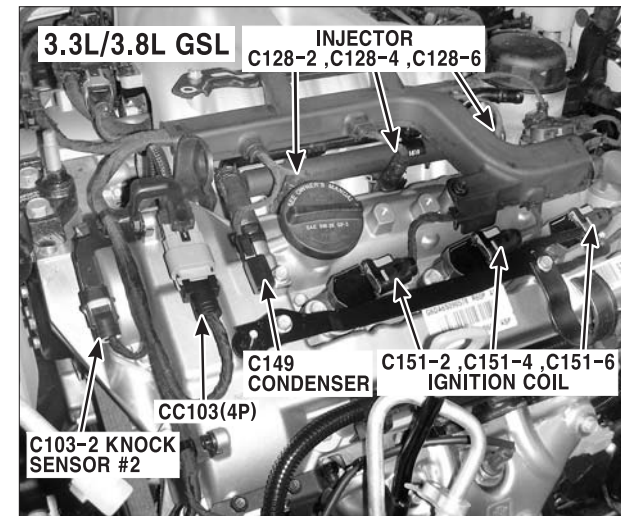

PHOTO.30



# COMPONENT LOCATIONS

## COMPONENT LOCATIONS (6)

CL-6

PHOTO.31

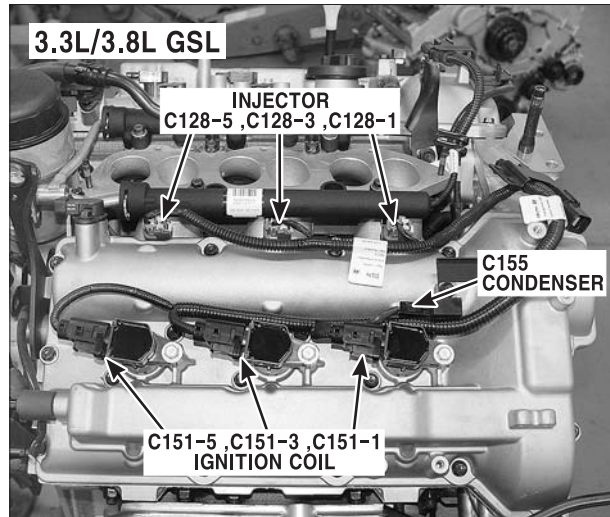

PHOTO.32

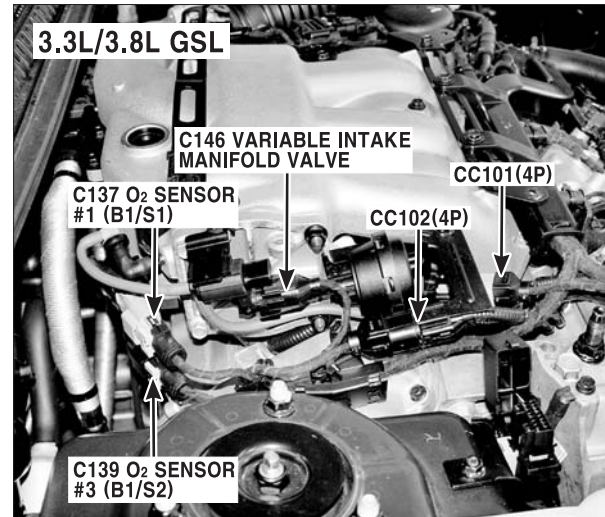

PHOTO.33

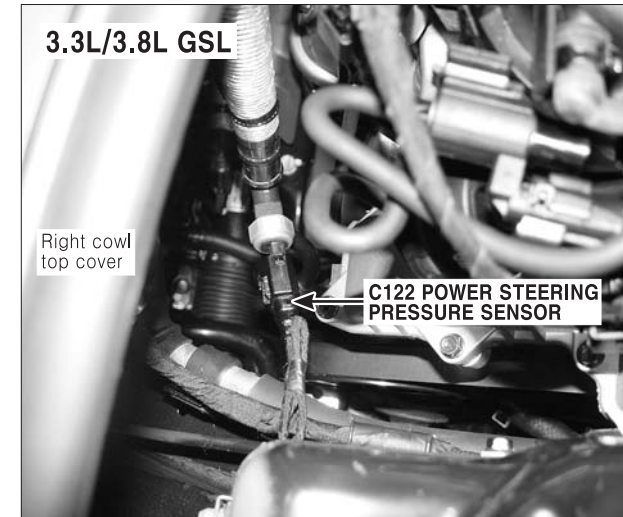

PHOTO.34

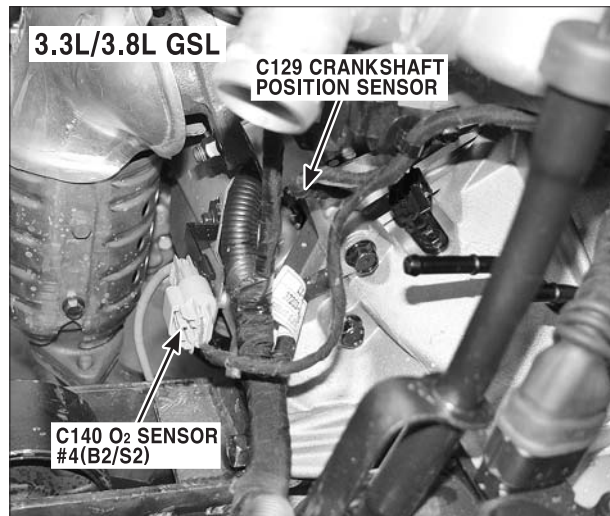

PHOTO.35

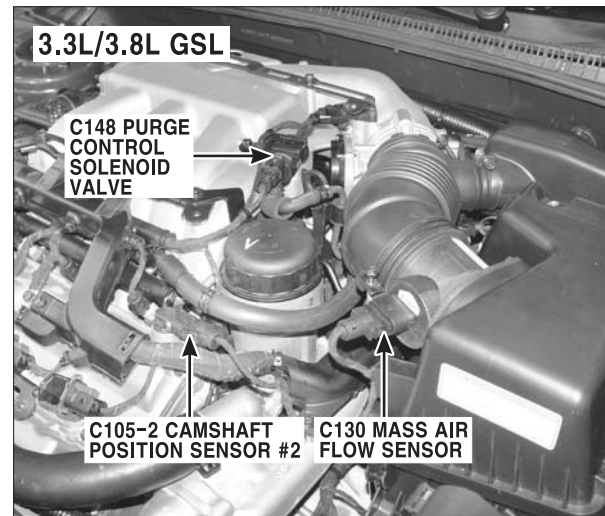
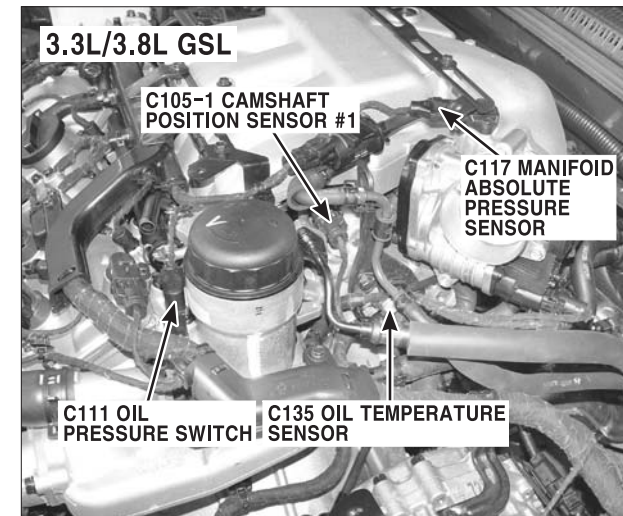

PHOTO.36



# COMPONENT LOCATIONS

## COMPONENT LOCATIONS (7)

CL-7

PHOTO.37

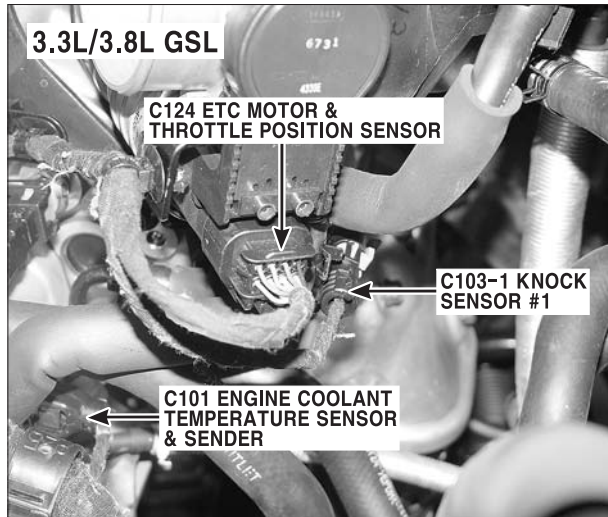

PHOTO.38

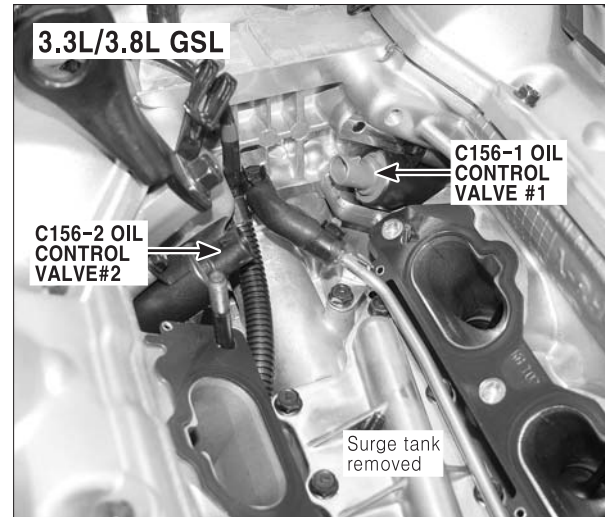

PHOTO.39

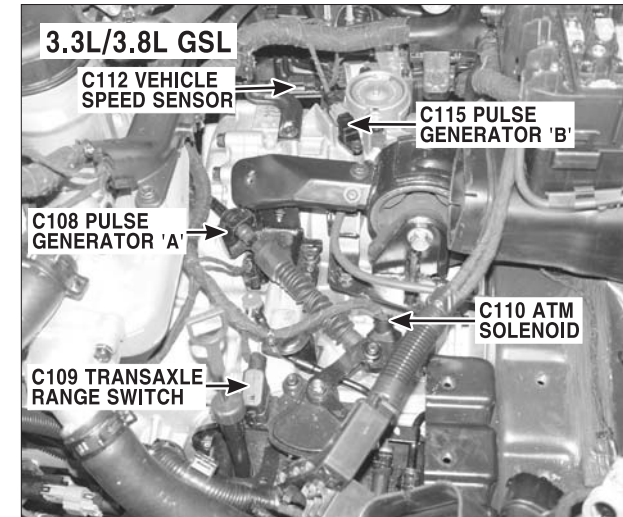

PHOTO.40

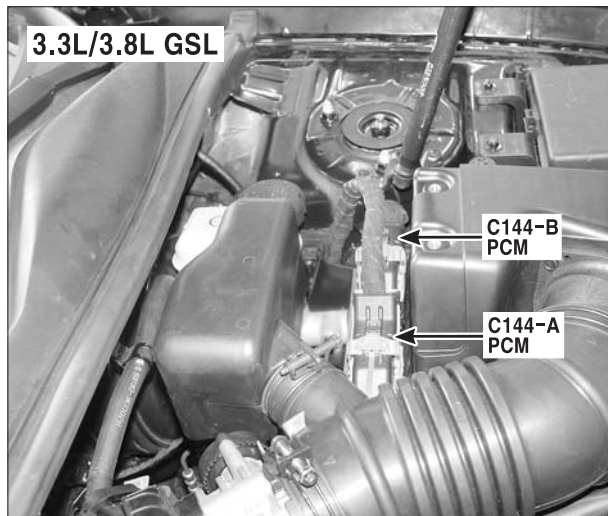

PHOTO.41

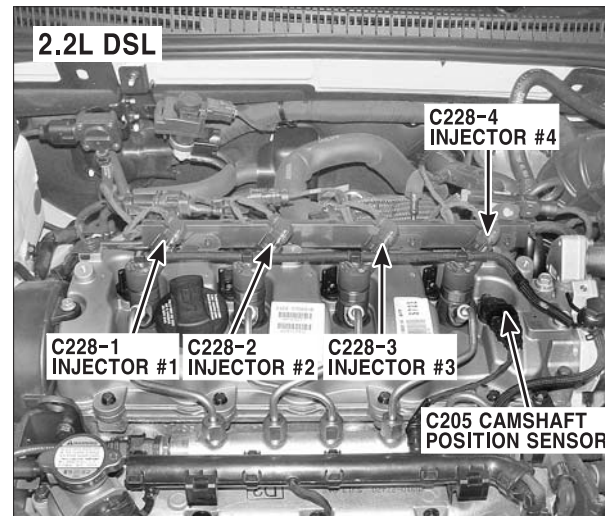
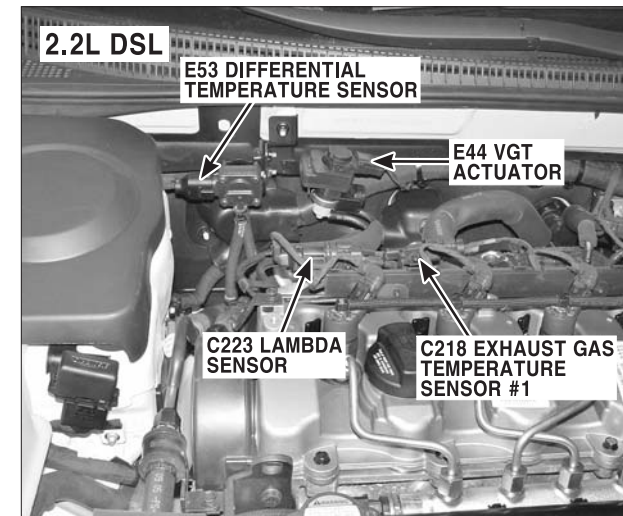

PHOTO.42



**COMPONENT LOCATIONS**

**COMPONENT LOCATIONS (8)**

**CL-8**

**PHOTO.43**

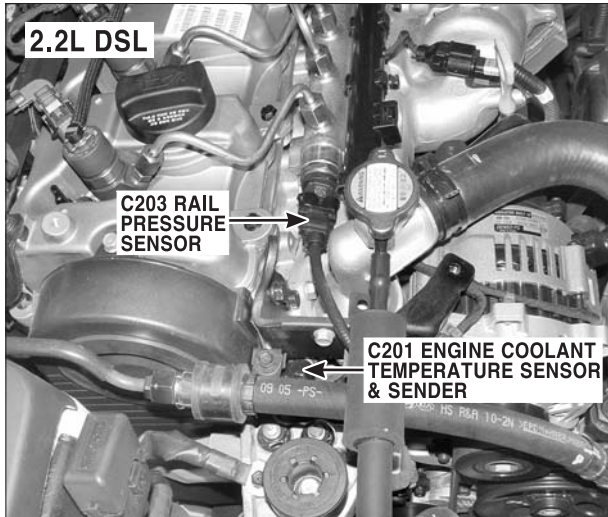

**PHOTO.44**

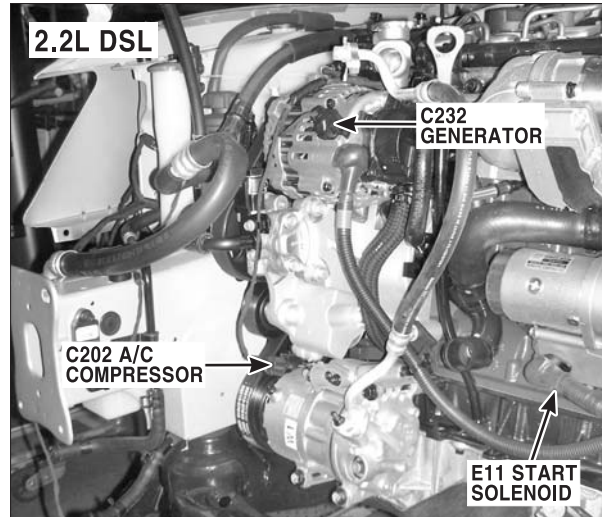

**PHOTO.45**

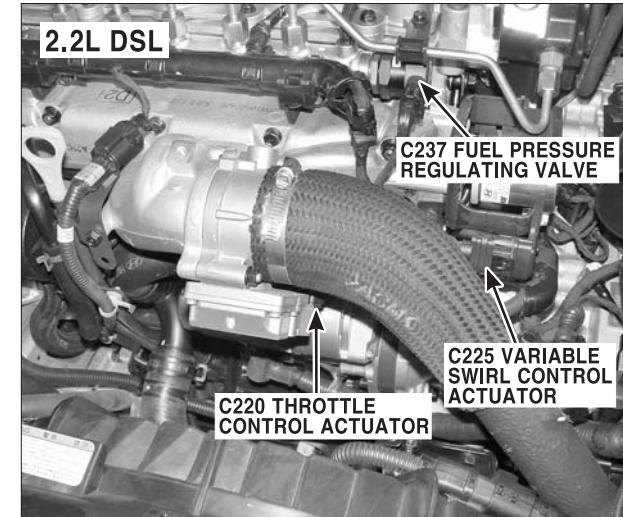

**PHOTO.46**

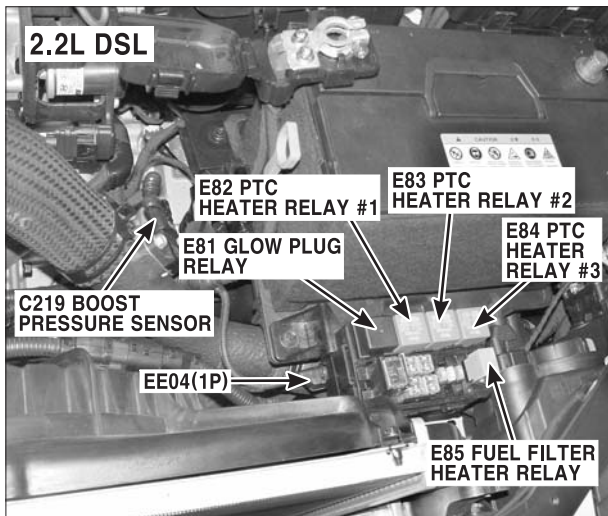

**PHOTO.47**

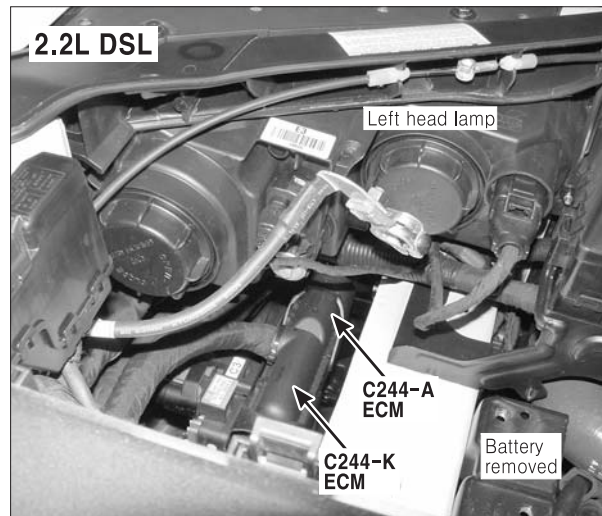

**PHOTO.48**

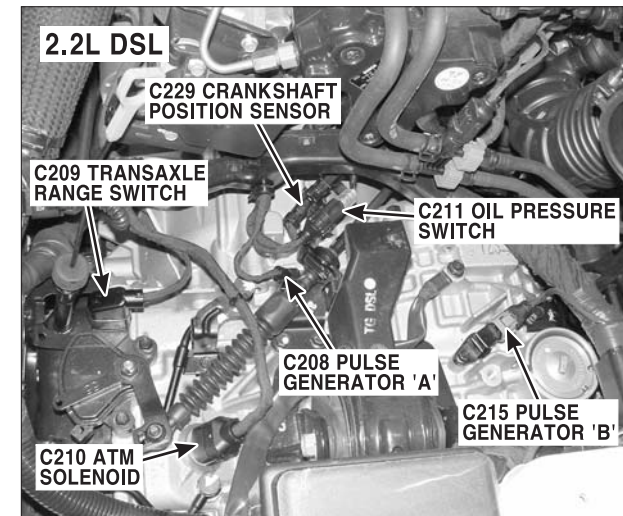

# COMPONENT LOCATIONS

## COMPONENT LOCATIONS (9)

CL-9

PHOTO.49

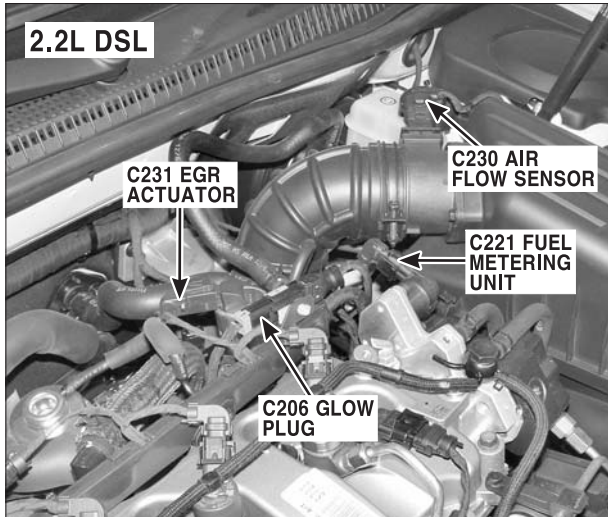

PHOTO.50

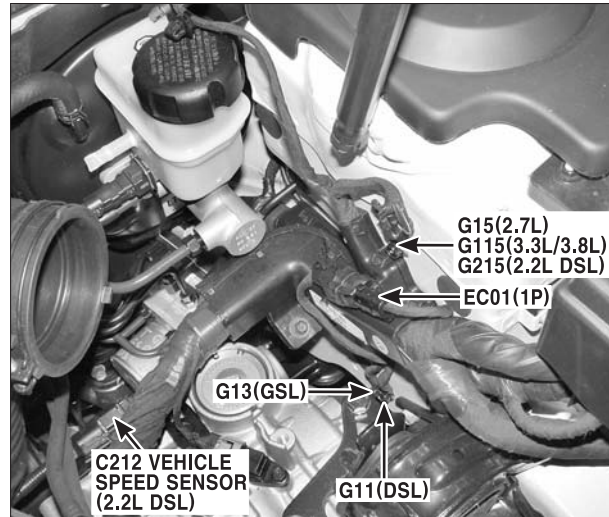

PHOTO.51

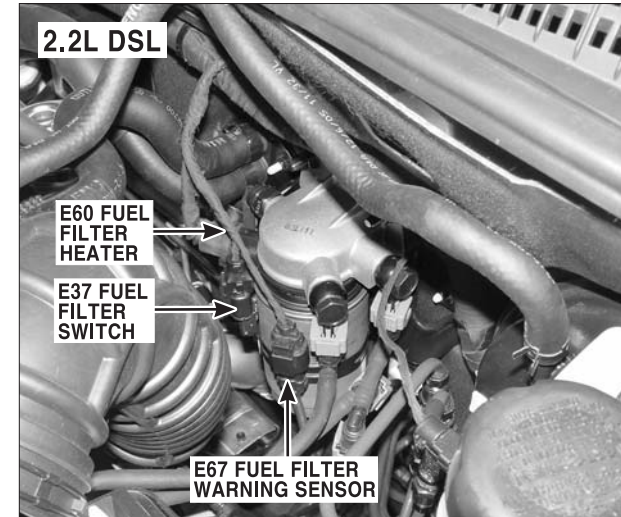

PHOTO.52

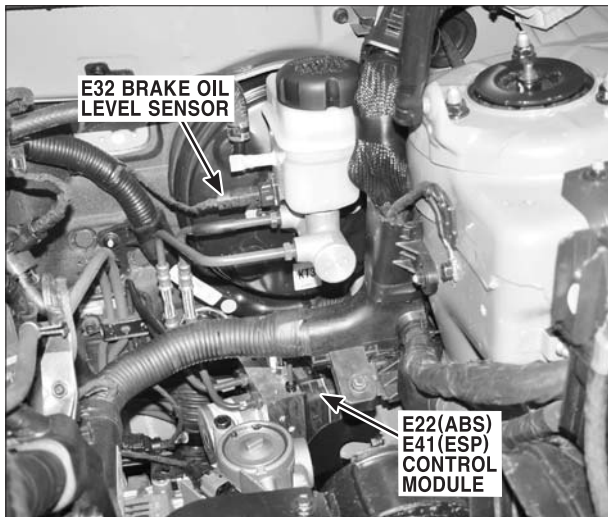

PHOTO.53

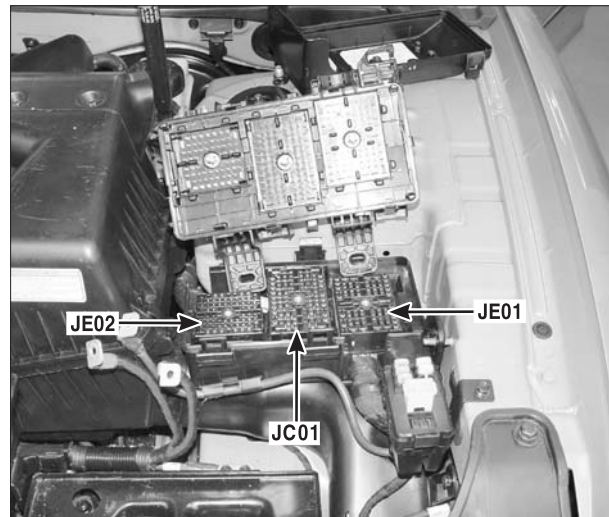
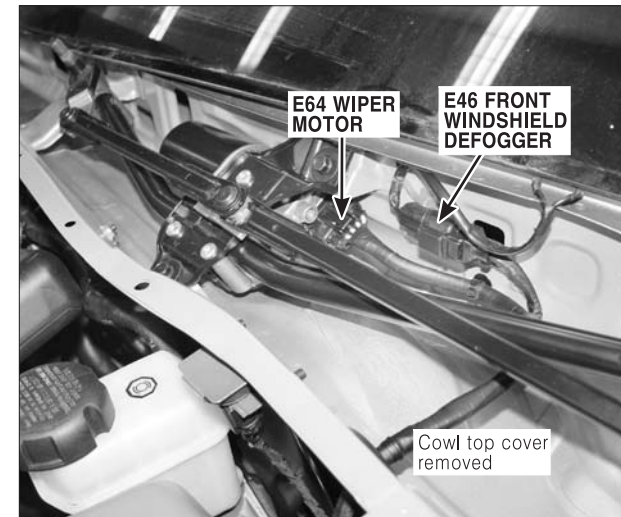

PHOTO.54



# COMPONENT LOCATIONS

## COMPONENT LOCATIONS (10)

CL-10

PHOTO.55



PHOTO.56

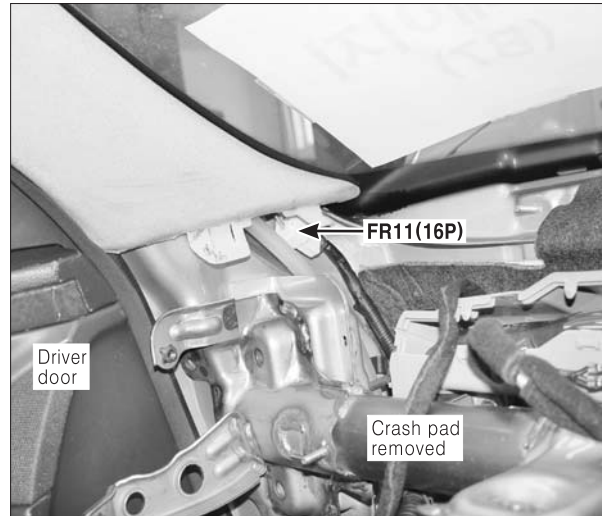

PHOTO.57

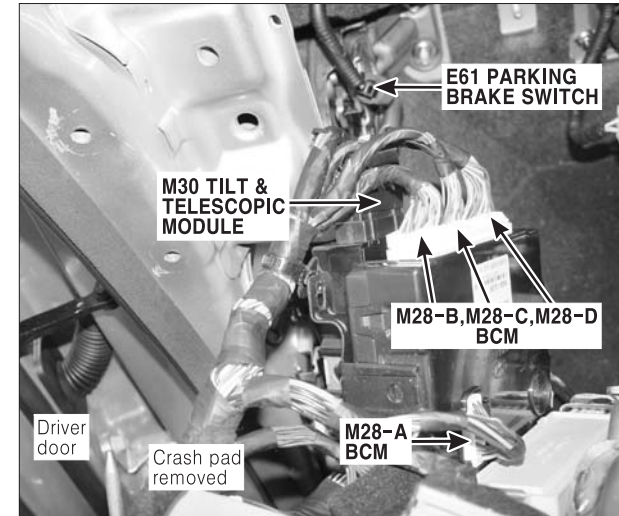

PHOTO.58

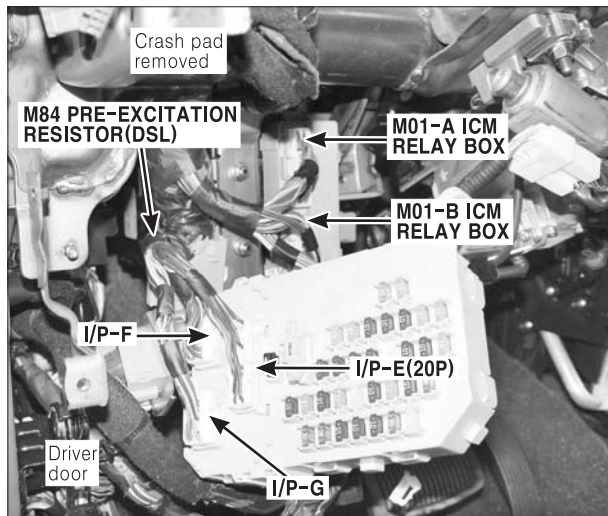

PHOTO.59

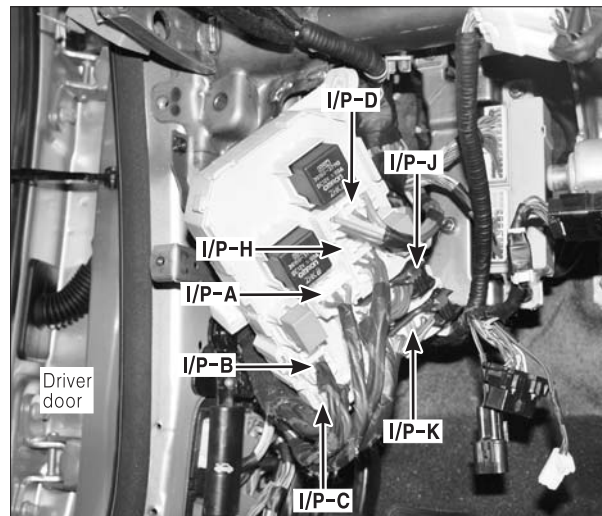
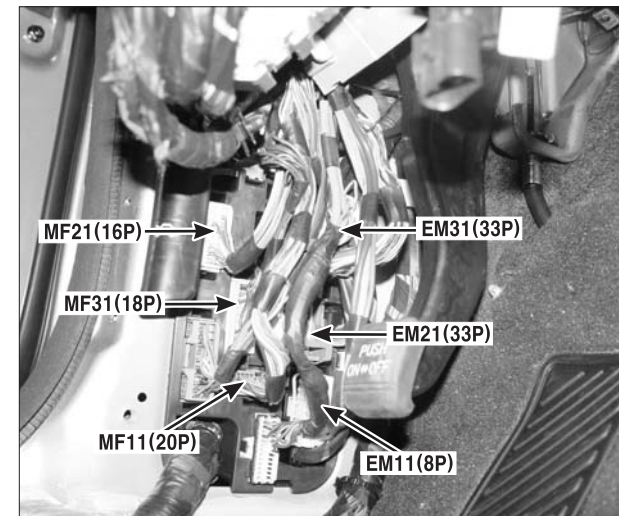

PHOTO.60



# COMPONENT LOCATIONS

## COMPONENT LOCATIONS (11)

CL-11

PHOTO.61

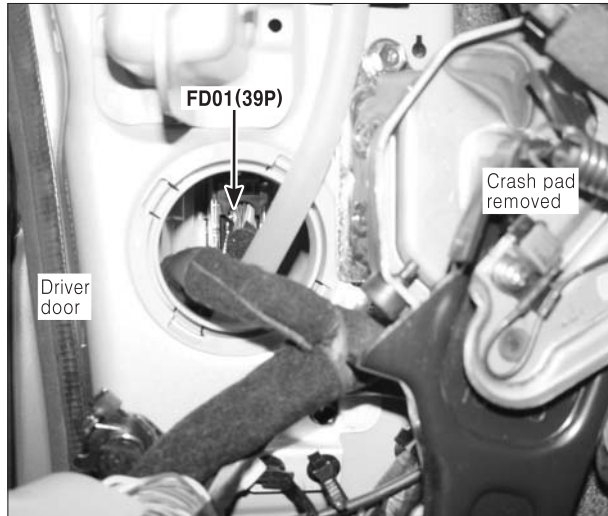

PHOTO.62

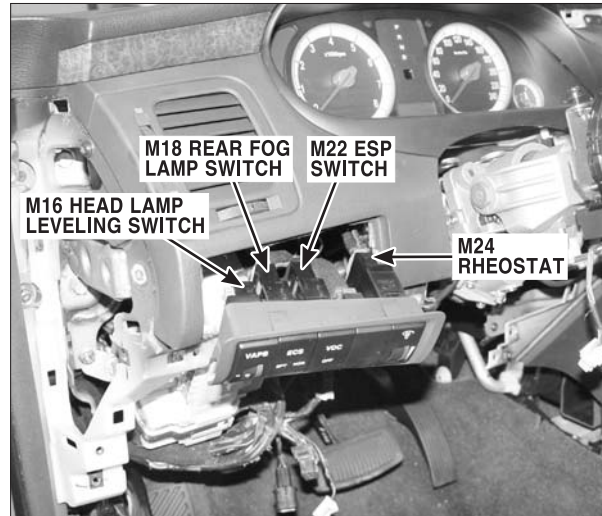

PHOTO.63

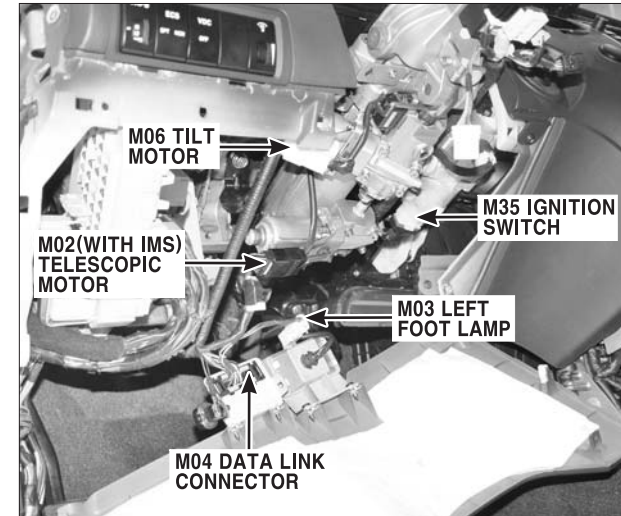

PHOTO.64

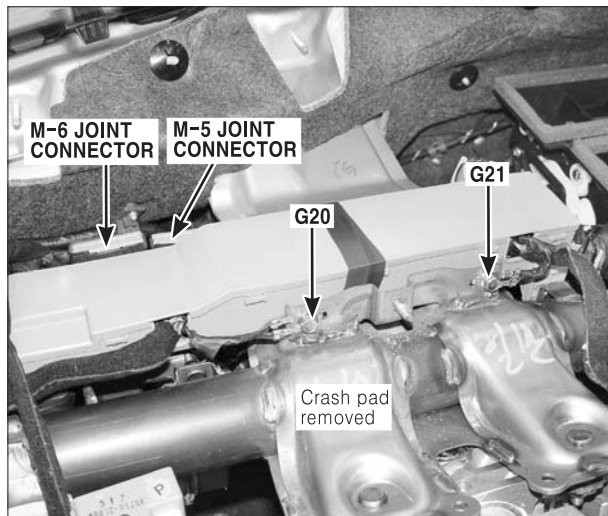
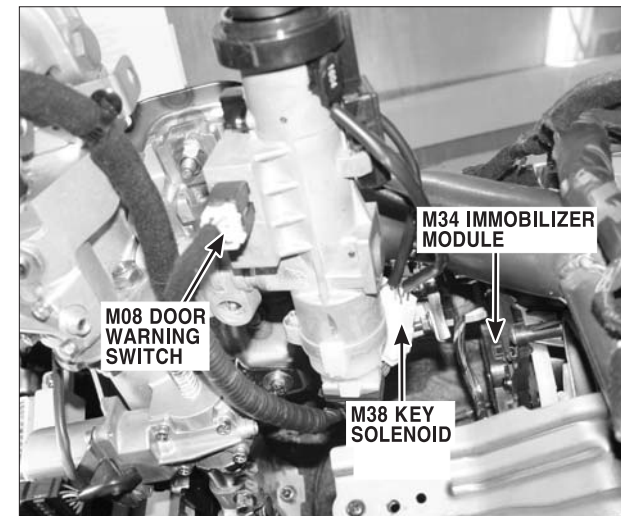

PHOTO.65



PHOTO.66



# COMPONENT LOCATIONS

## COMPONENT LOCATIONS (12)

CL-12

PHOTO.67

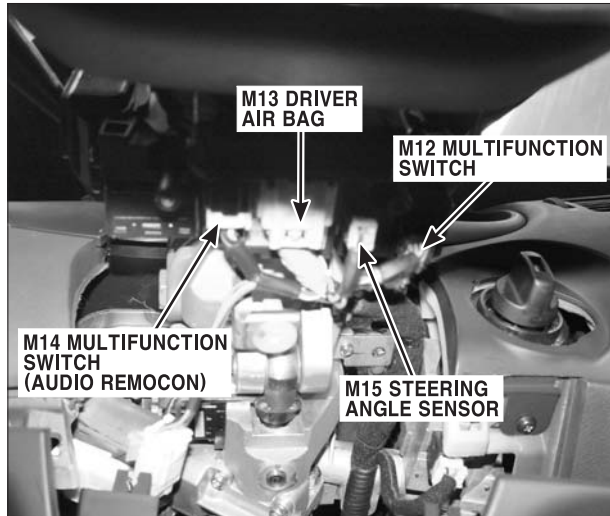

PHOTO.68

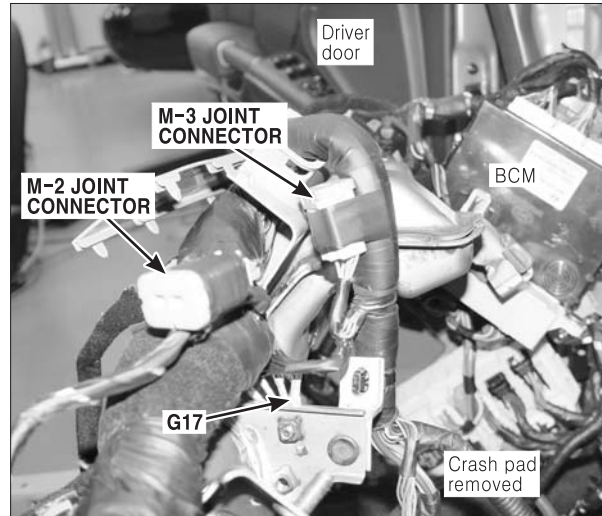

PHOTO.69

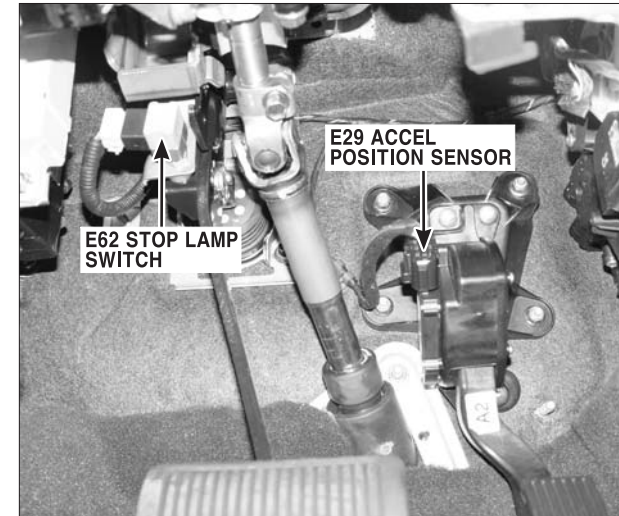

PHOTO.70

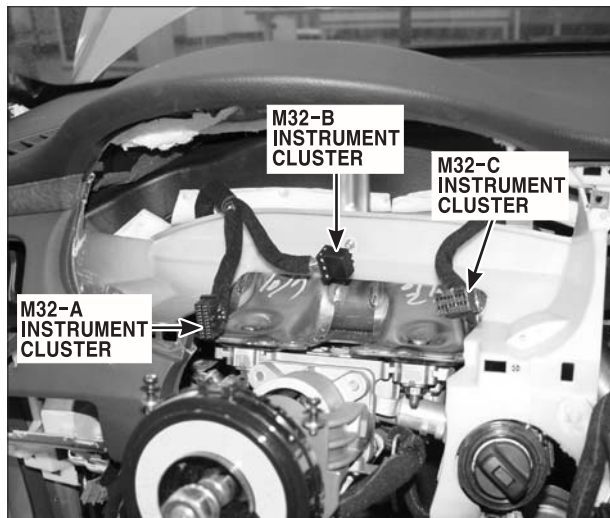

PHOTO.71



PHOTO.72





**COMPONENT LOCATIONS**

**COMPONENT LOCATIONS (13)**

**CL-13**

**PHOTO.73**

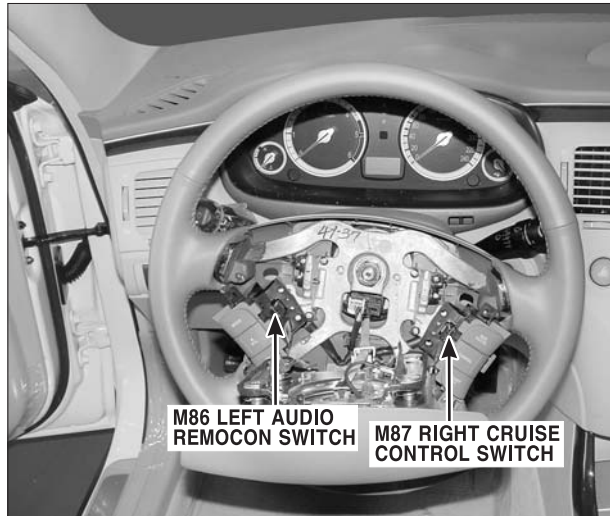

**PHOTO.74**

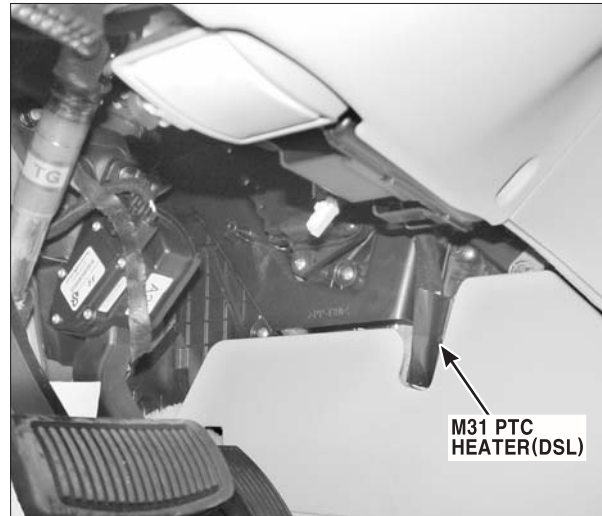

**PHOTO.75**

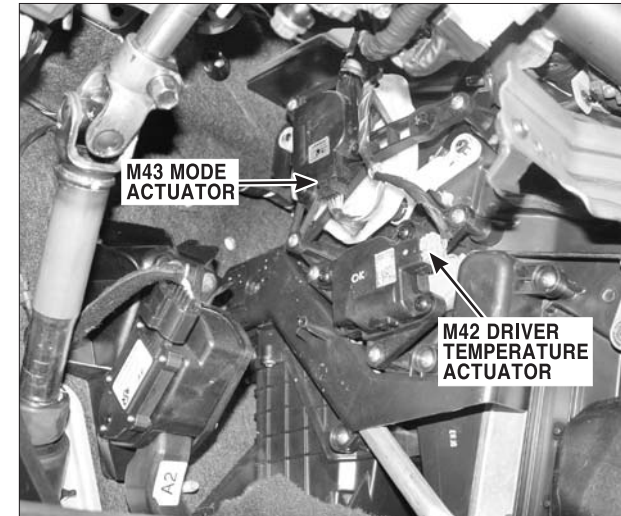

**PHOTO.76**

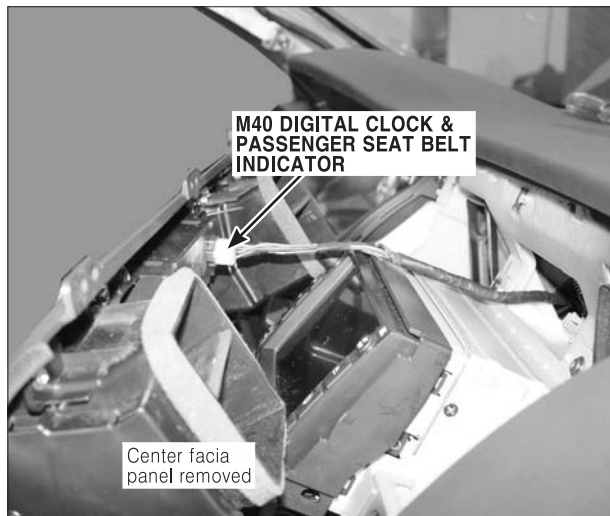

**PHOTO.77**



**PHOTO.78**



# COMPONENT LOCATIONS

## COMPONENT LOCATIONS (14)

CL-14

PHOTO.79

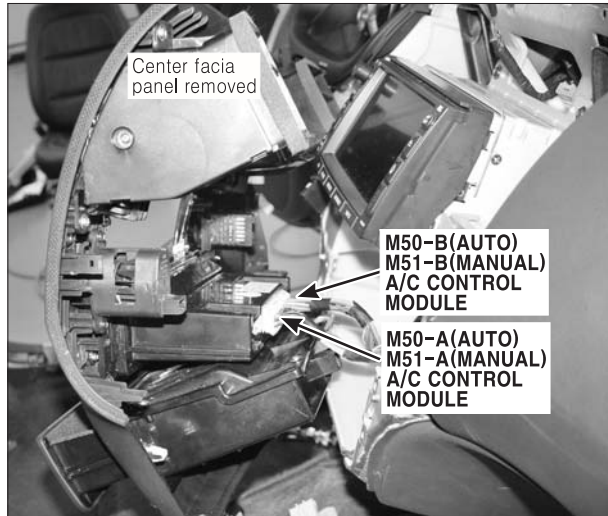

PHOTO.80

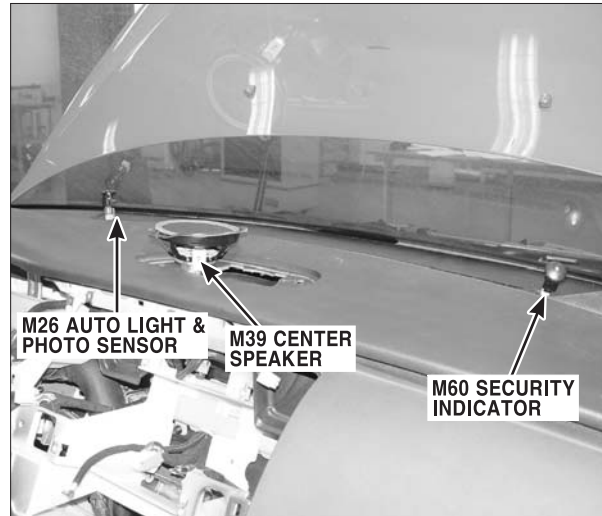

PHOTO.81

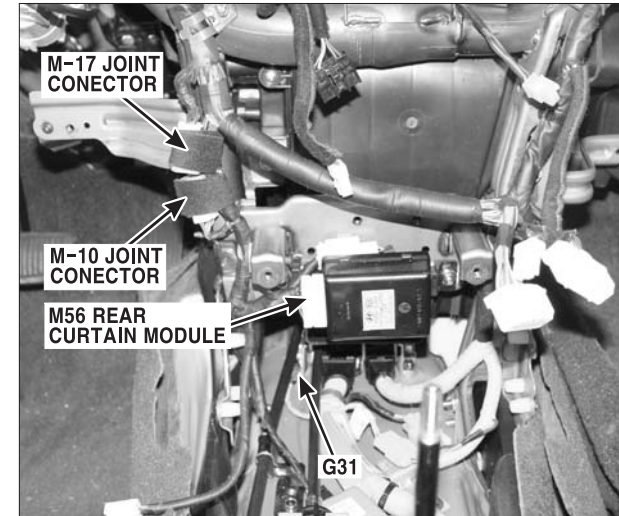

PHOTO.82

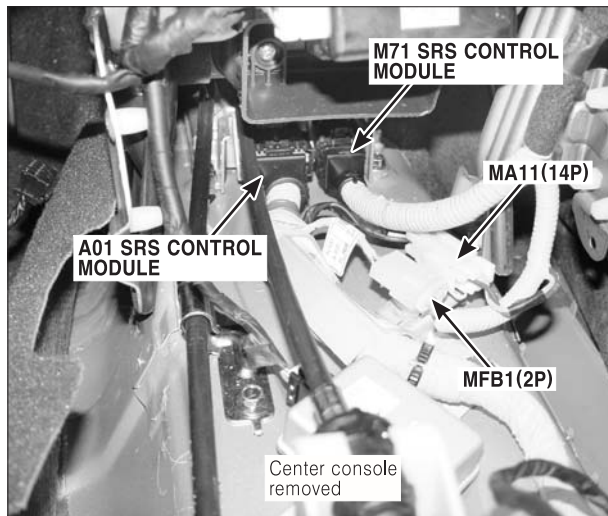

PHOTO.83

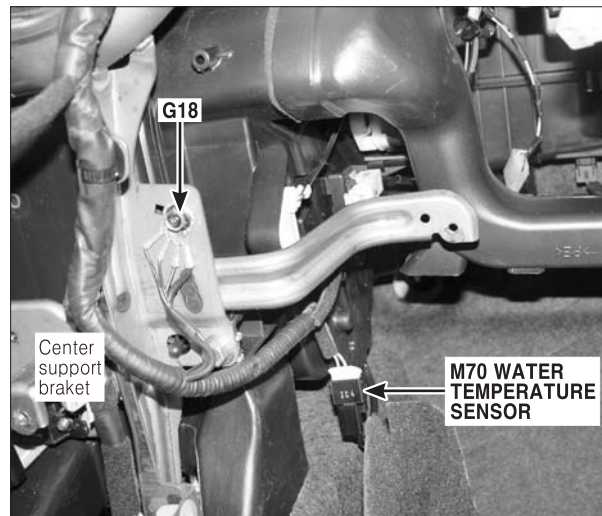
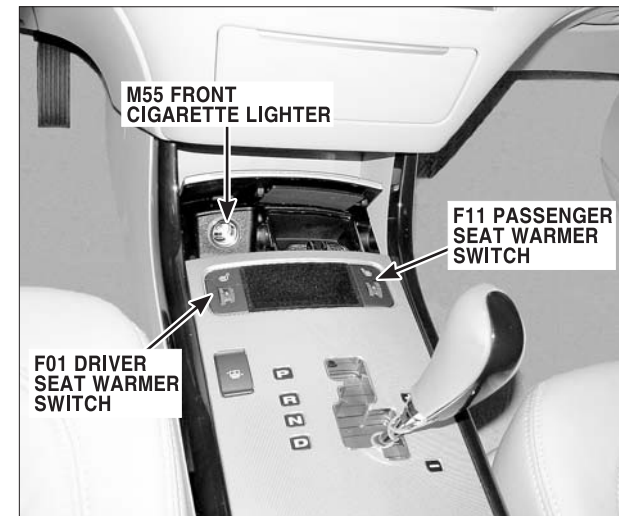

PHOTO.84



**COMPONENT LOCATIONS**

**COMPONENT LOCATIONS (15)**

**CL-15**

**PHOTO.85**

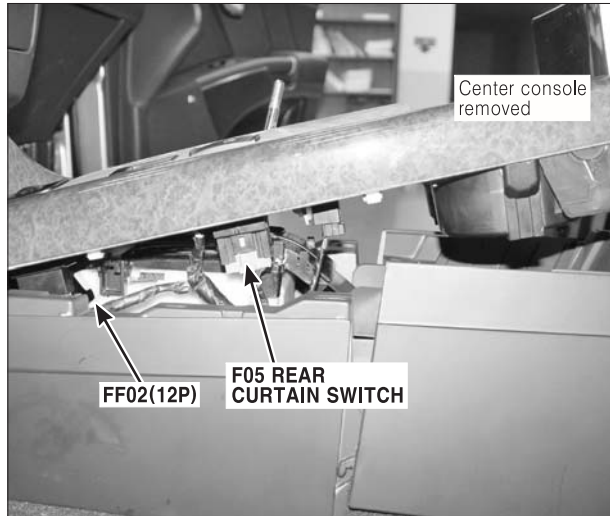

**PHOTO.86**

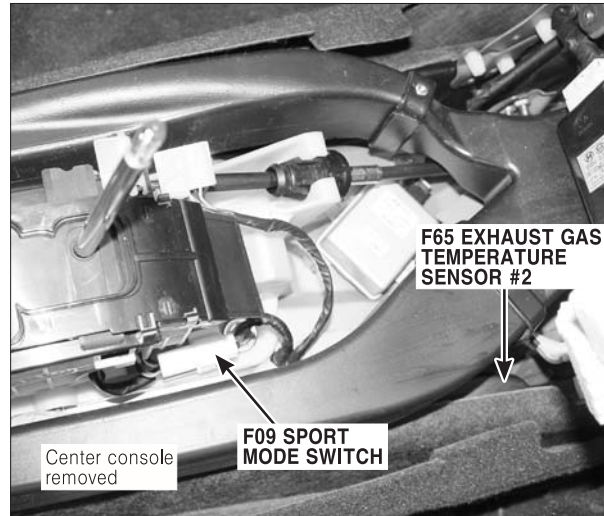

**PHOTO.87**

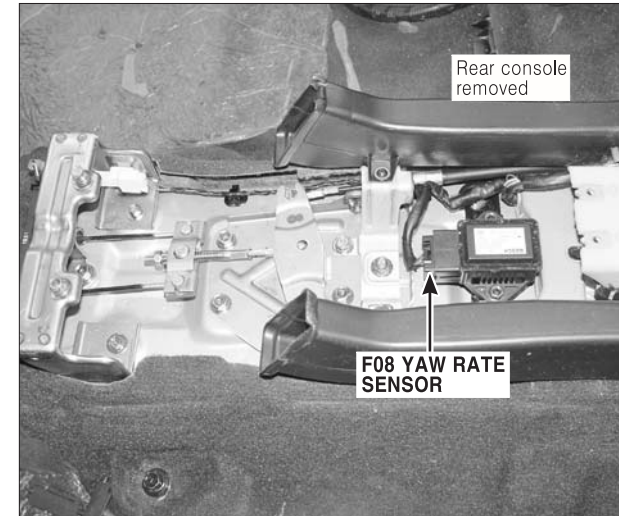

**PHOTO.88**

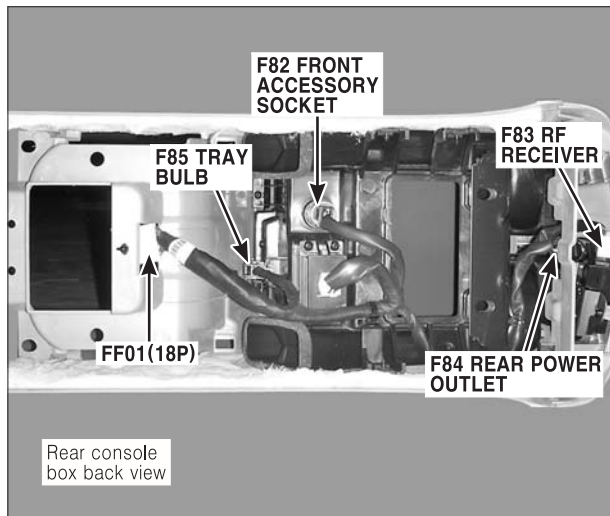

**PHOTO.89**

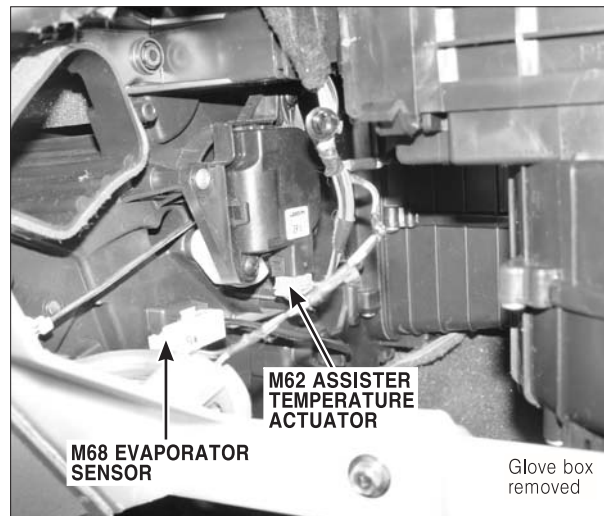

**PHOTO.90**

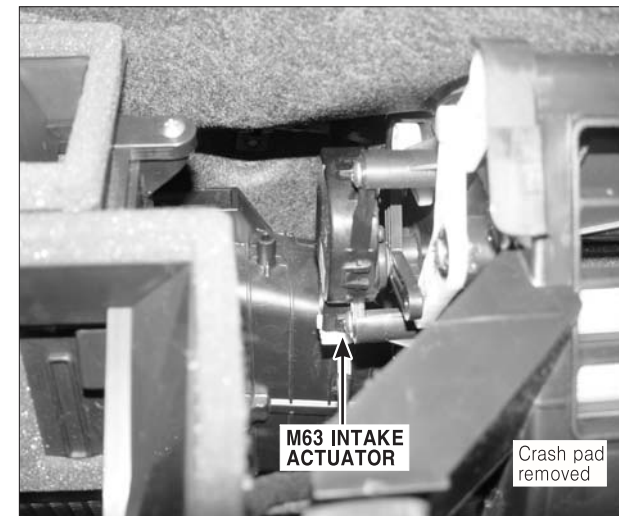

# COMPONENT LOCATIONS

## COMPONENT LOCATIONS (16)

CL-16

PHOTO.91

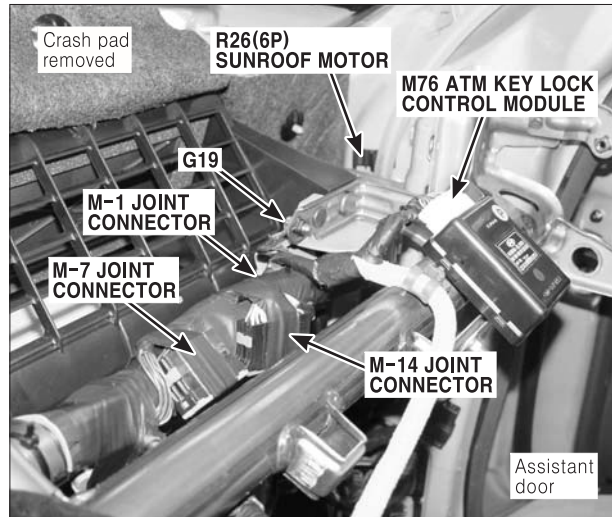

PHOTO.92



PHOTO.93

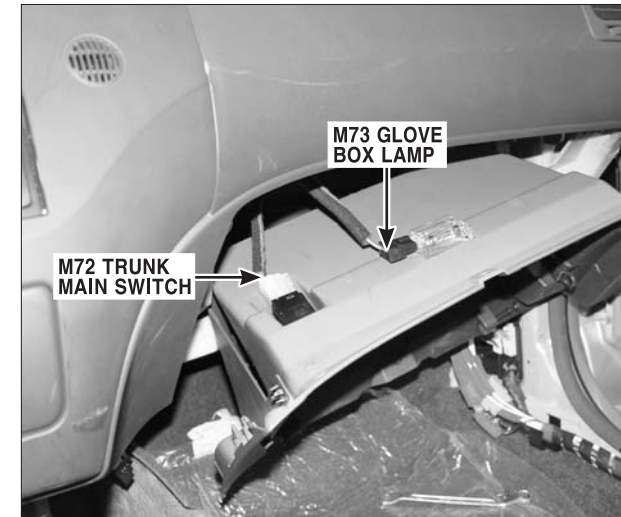

PHOTO.94

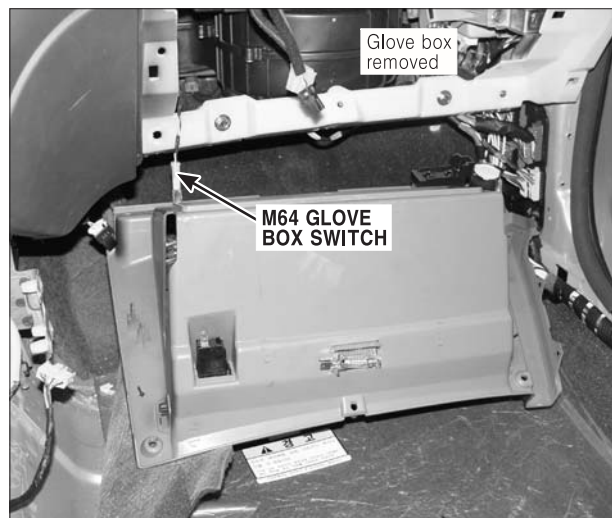

PHOTO.95

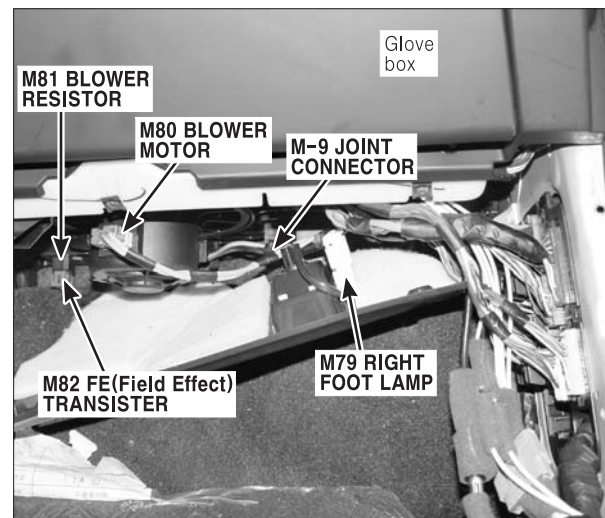
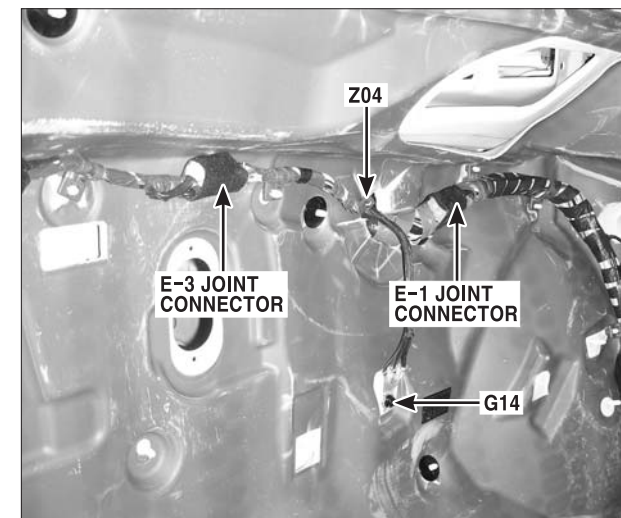

PHOTO.96



# COMPONENT LOCATIONS

## COMPONENT LOCATIONS (17)

CL-17

PHOTO.97

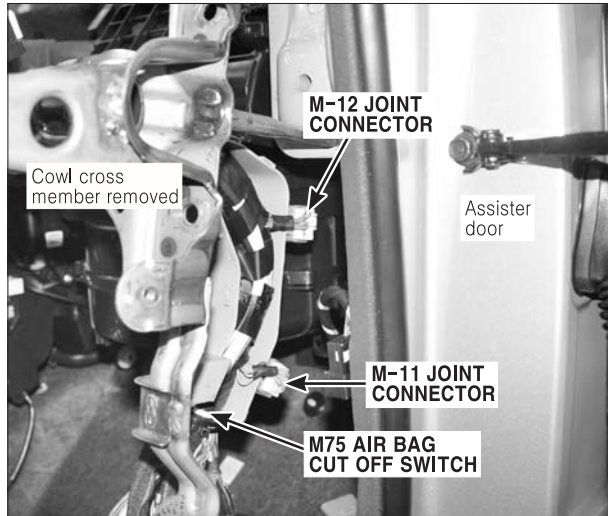

PHOTO.98

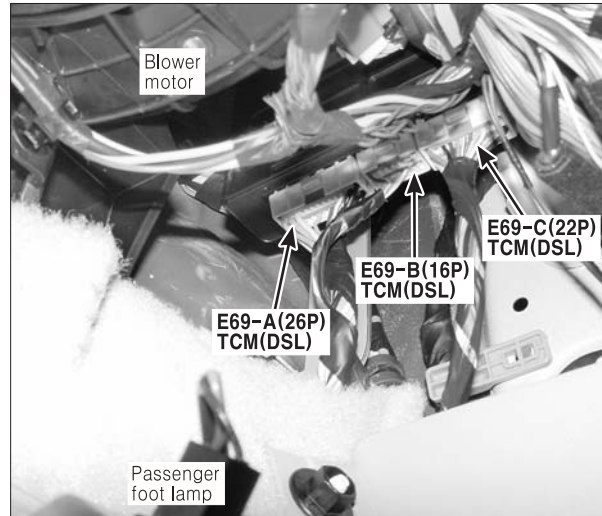

PHOTO.99

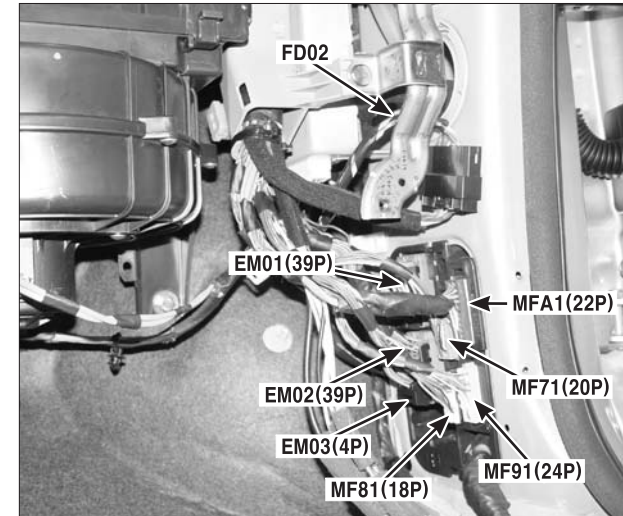

PHOTO.100



PHOTO.101



PHOTO.102

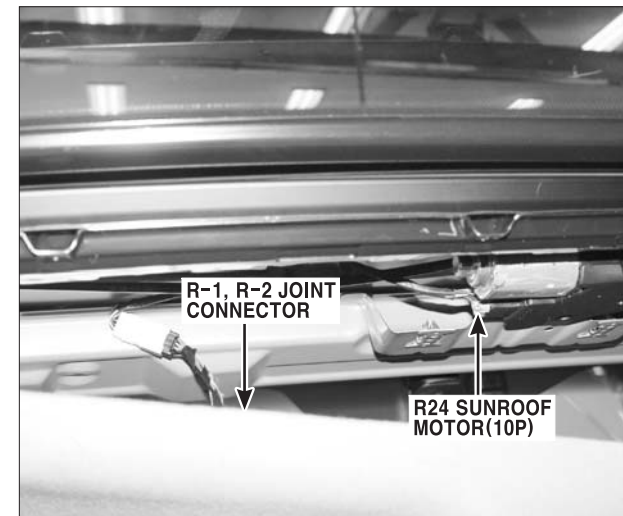

# COMPONENT LOCATIONS

## COMPONENT LOCATIONS (18)

CL-18

PHOTO.103

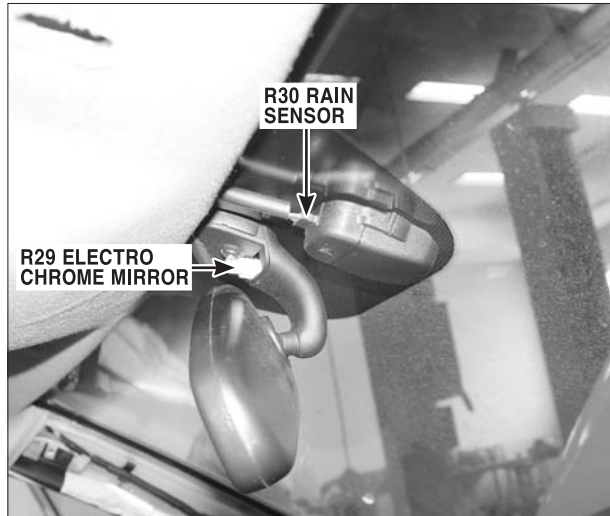

PHOTO.104



PHOTO.105

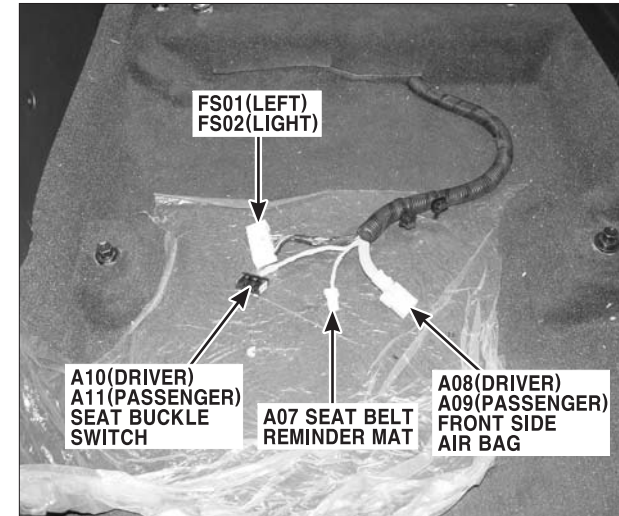

PHOTO.106

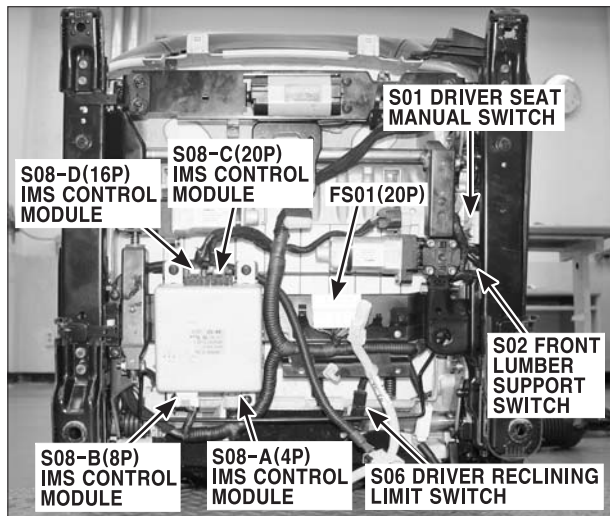

PHOTO.107

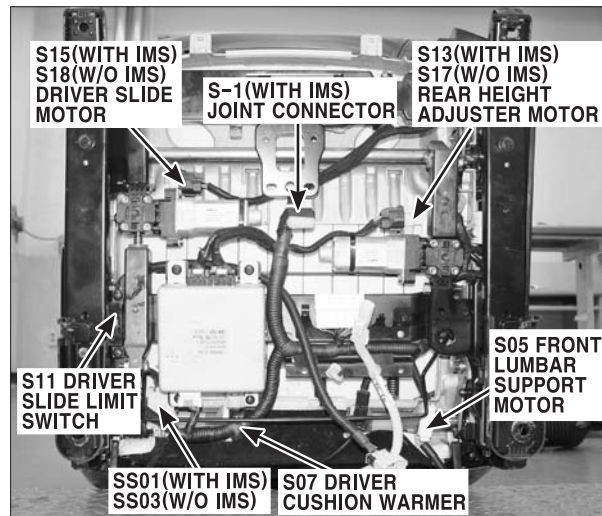
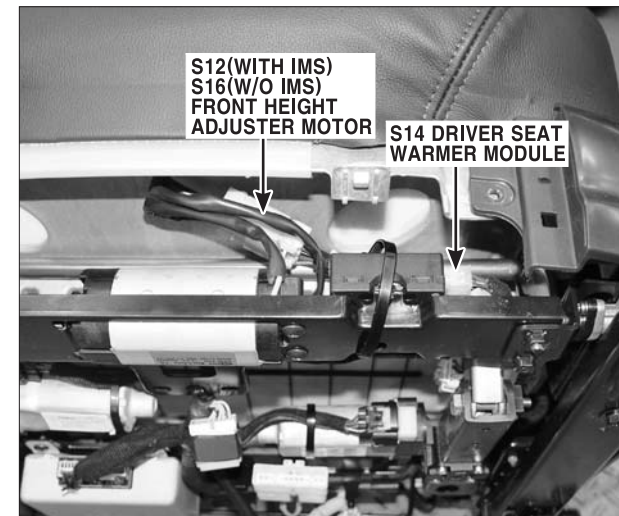

PHOTO.108



# COMPONENT LOCATIONS

## COMPONENT LOCATIONS (19)

CL-19

PHOTO.109

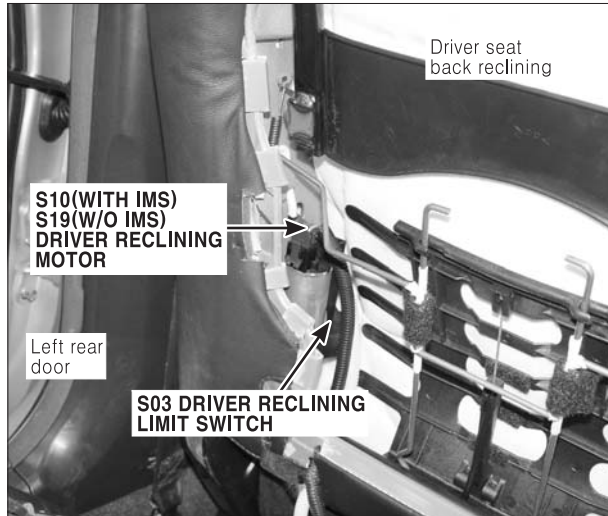

PHOTO.110

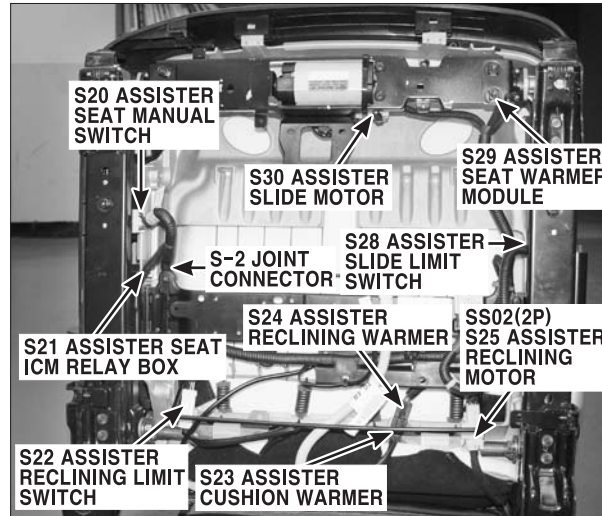

PHOTO.111

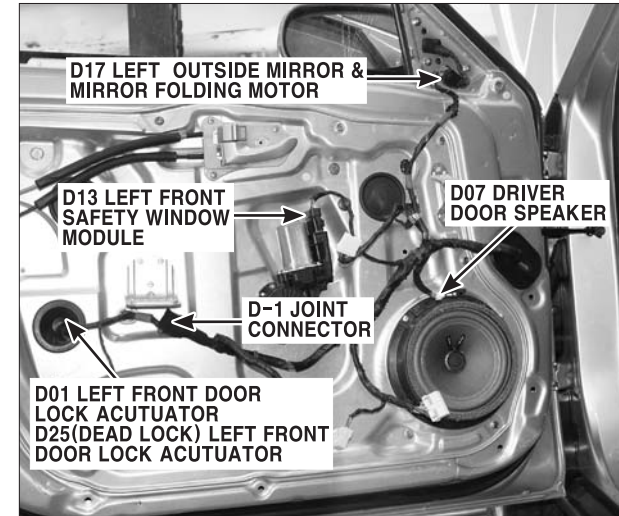

PHOTO.112

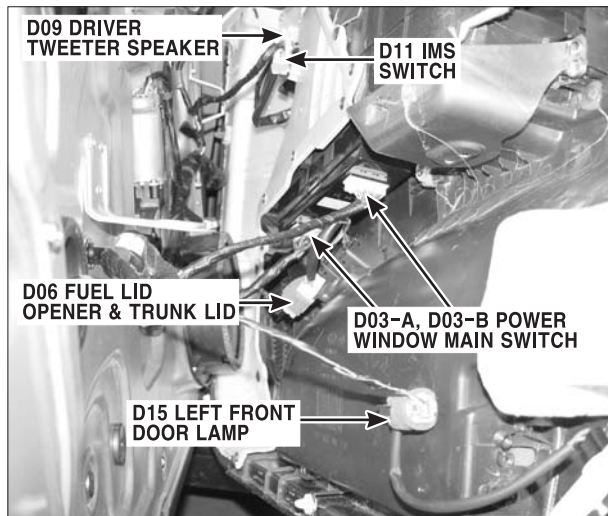

PHOTO.113

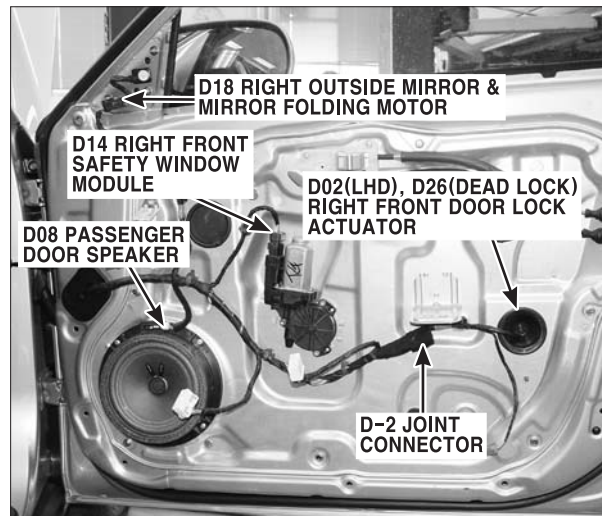
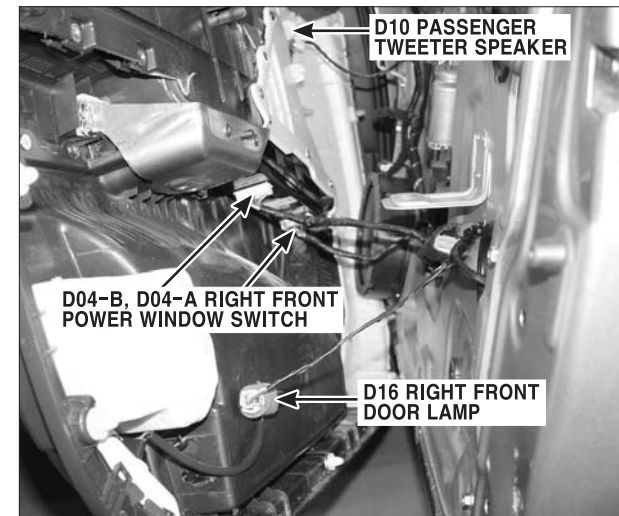

PHOTO.114



# COMPONENT LOCATIONS

## COMPONENT LOCATIONS (20)

CL-20

PHOTO.115

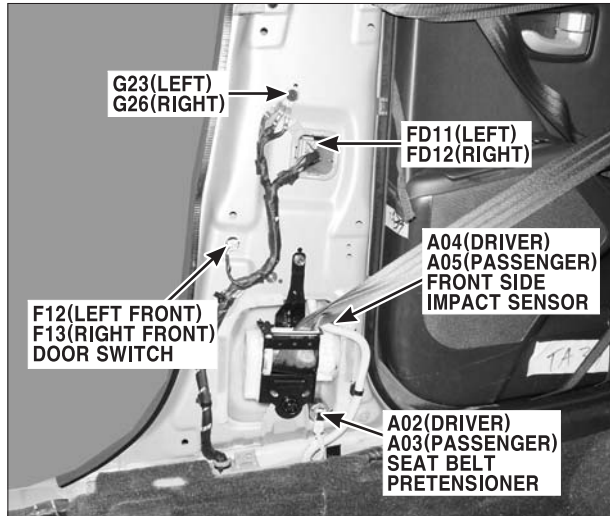

PHOTO.116

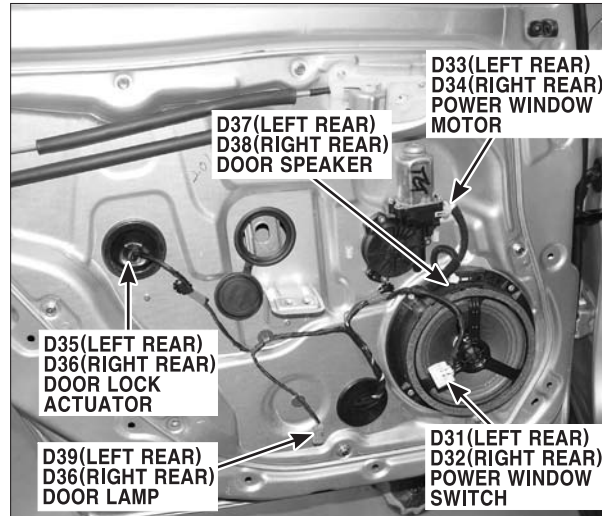

PHOTO.117

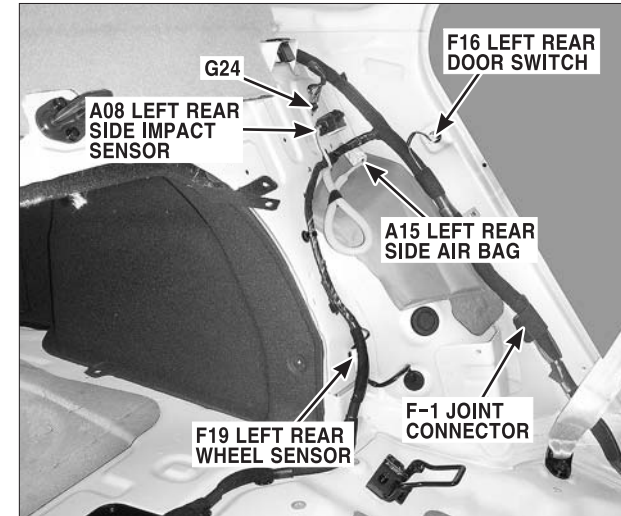

PHOTO.118

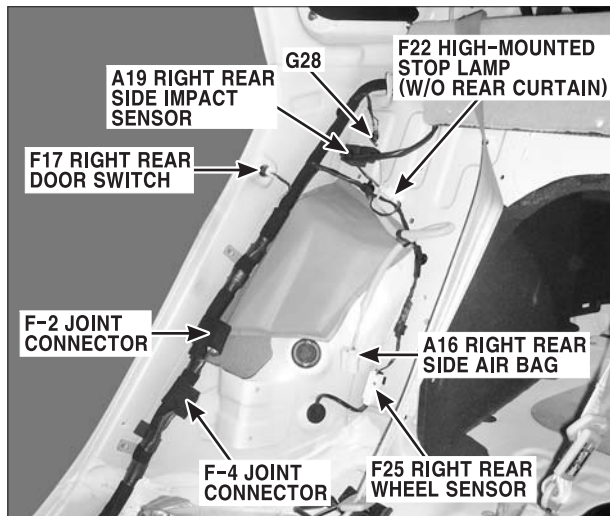

PHOTO.119

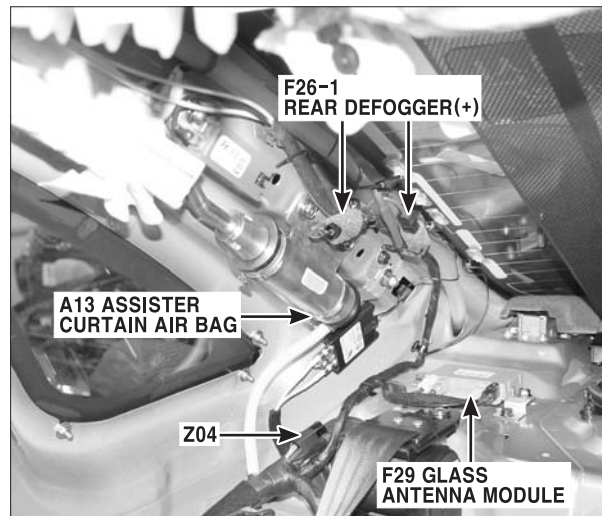
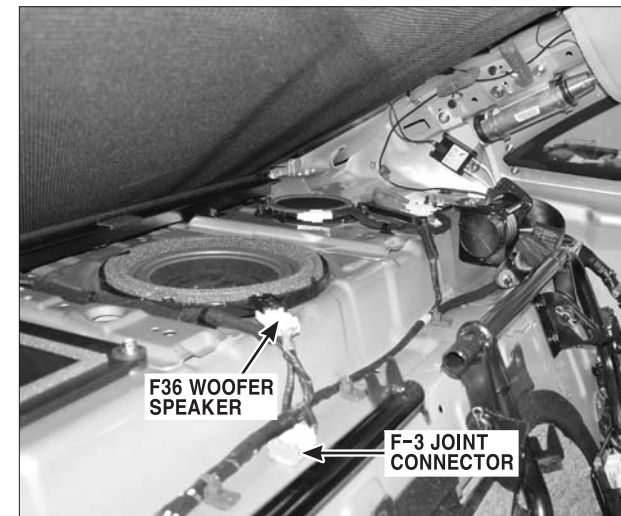

PHOTO.120





# COMPONENT LOCATIONS

## COMPONENT LOCATIONS (21)

CL-21

PHOTO.121



PHOTO.122

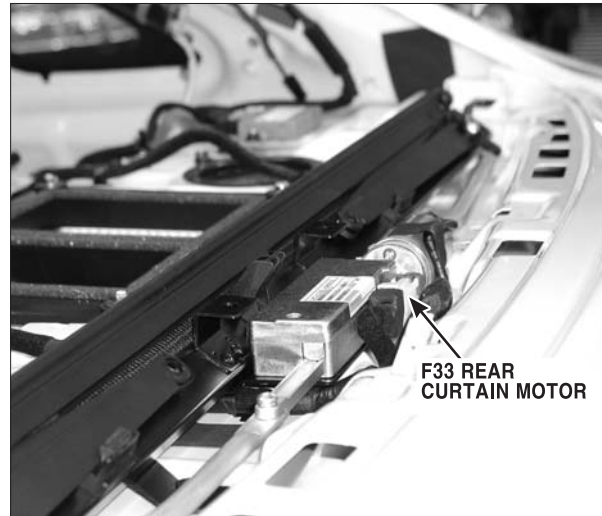

PHOTO.123



PHOTO.124

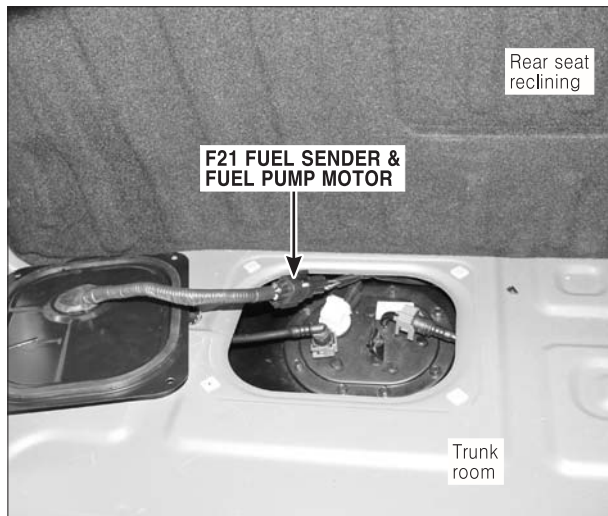

PHOTO.125

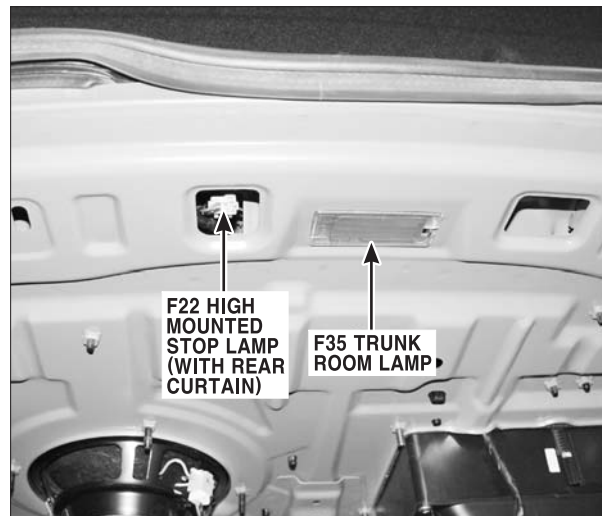
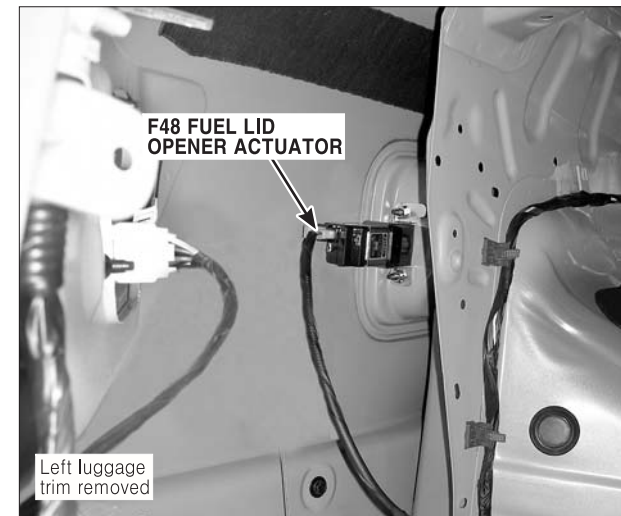

PHOTO.126



# COMPONENT LOCATIONS

## COMPONENT LOCATIONS (22)

CL-22

PHOTO.127



PHOTO.128

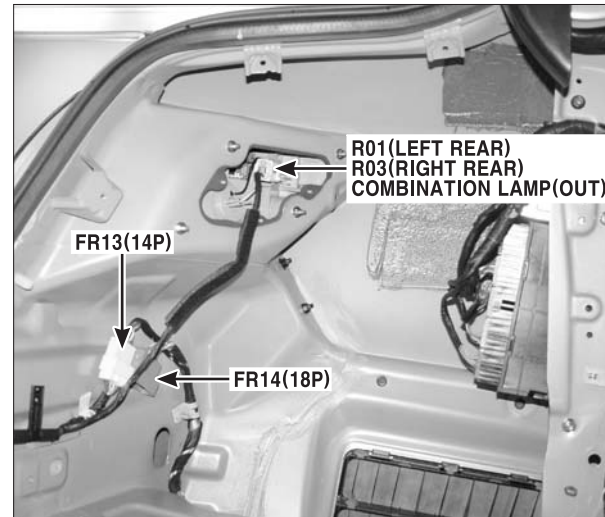

PHOTO.129

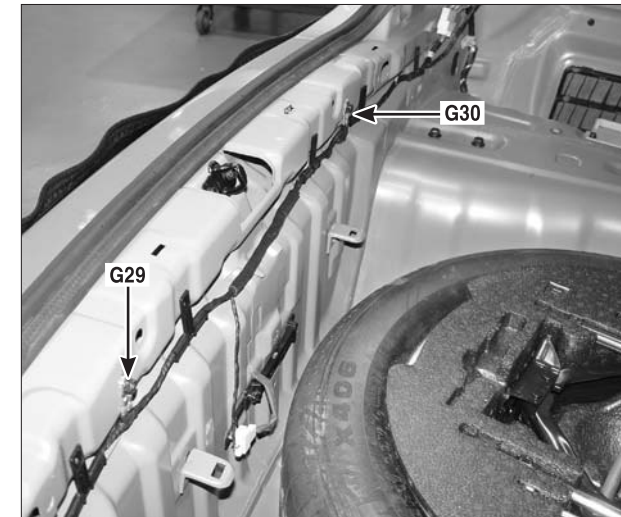

PHOTO.130

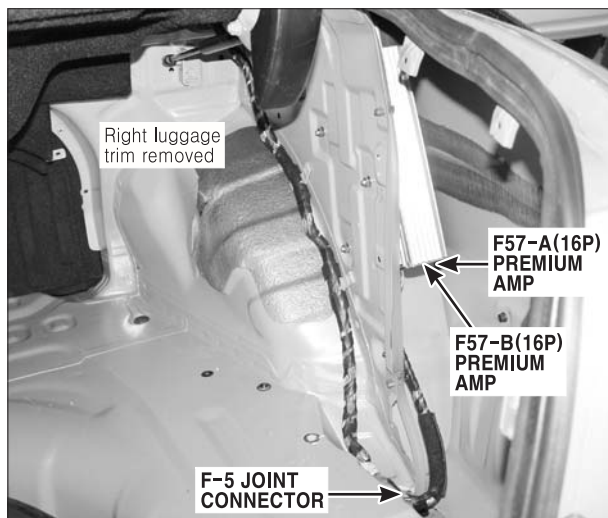

PHOTO.131

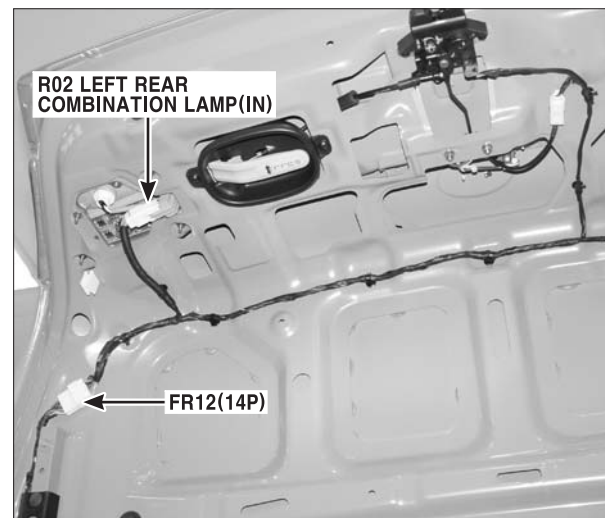
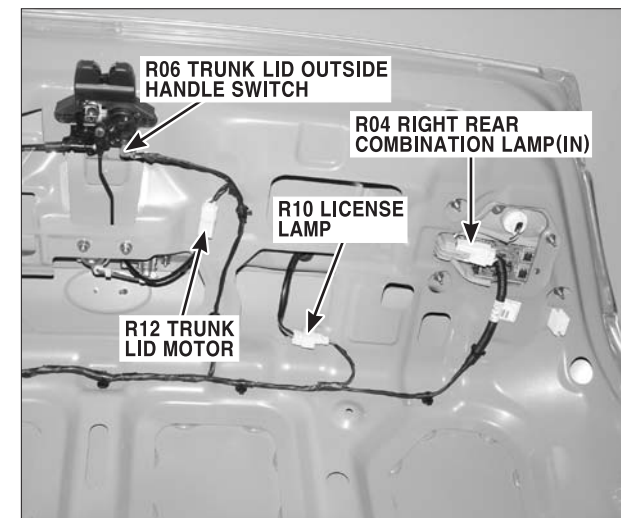

PHOTO.132



## COMPONENT LOCATIONS

### COMPONENT LOCATIONS (23)

CL-23

PHOTO.133

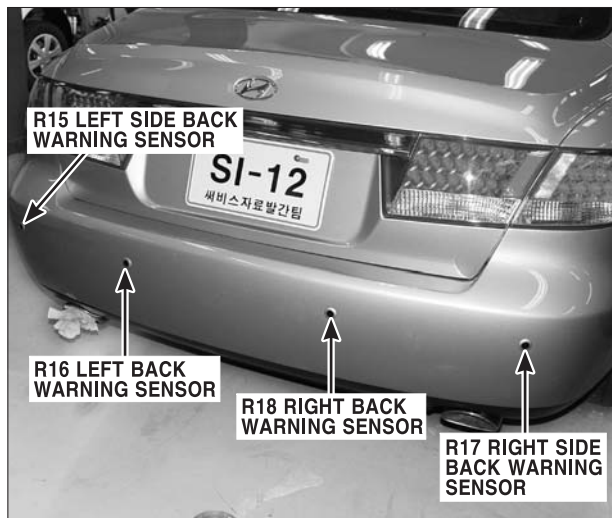

**HARNESS CONNECTOR (1)**

**CC-1**

**CC01**

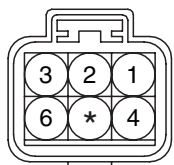

KUM\_NMWP\_06F\_B

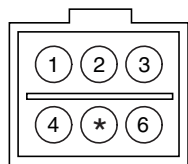

NMWP\_06P\_M(BLACK)

**CC02**

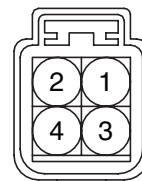

KUM\_NMWP\_04F\_Gr

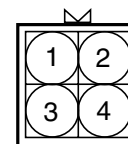

CR04M001

**CC101**

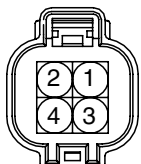

KUM\_KNMWP\_04F\_Gr

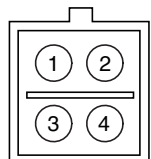

KUM\_NMWP\_PB621\_04120

**CC102**

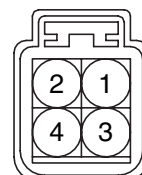

KUM\_NMWP\_04F\_B

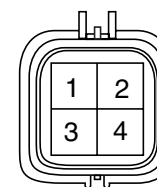

KUM\_PB625\_04020

**CC103**

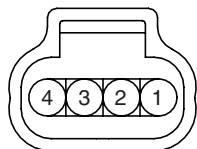

PKD\_GT150\_04F\_Gr

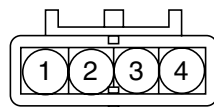

CR04M044

**EC01**



KET\_312IWP\_01F\_B



KET\_312IWP\_01M\_B

**EE01**

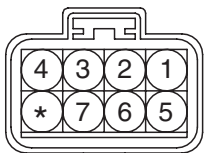

KUM\_NMWP\_08F\_B

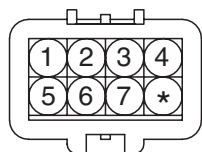

KUM\_NMWP\_08M\_B

**EE02**



KUM\_NMWP\_01F\_B



CR01M002

**EE04**



CR01F020

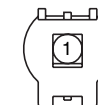

KUM\_NMWP\_01M\_B

**EM01**

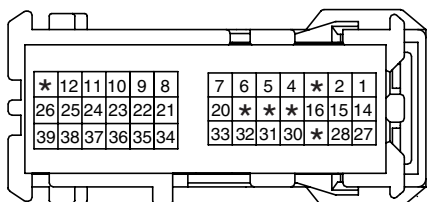

KET\_LIF0409\_39F\_L

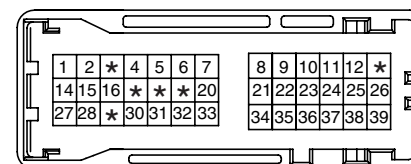

KET\_LIF0409\_39M\_L

# HARNES CONNECTOR

## HARNES CONNECTOR (2)

CC-2

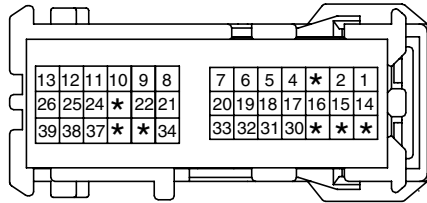

KET\_LIF0409\_39F\_Gr

EM02

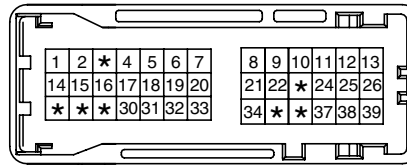

KET\_LIF0409\_39M\_Gr

EM03

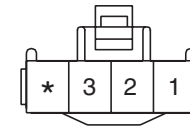

KET\_312II\_04F\_B

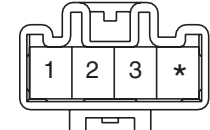

KET\_312II\_04M\_B

EM11

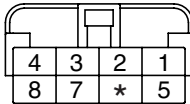

KET\_250DL\_08F\_W

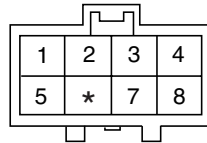

KET\_250DL\_08M\_W

EM21

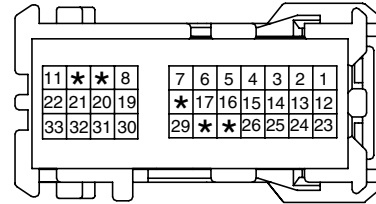

KET\_LIF0409\_33F\_W

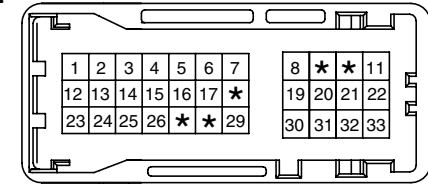

KET\_LIF0409\_33M\_W

EM31

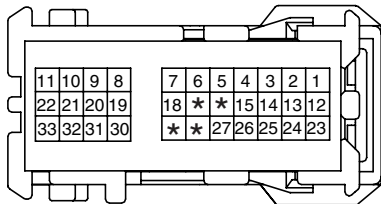

KET\_LIF0409\_33F\_B

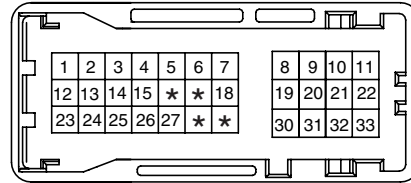

KET\_LIF0409\_33M\_B

EM41

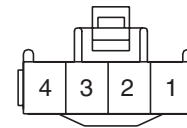

KET\_312II\_04F\_W

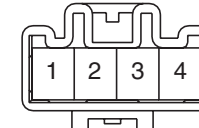

KET\_312II\_04M\_W

FD01

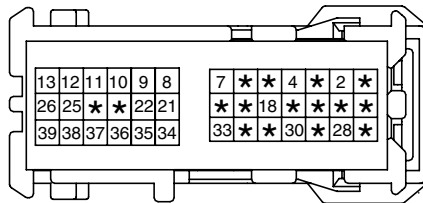

KET\_LIF0409\_39F\_W

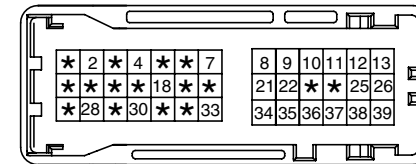

KET\_LIF0409\_39M\_W\_DR

FD02

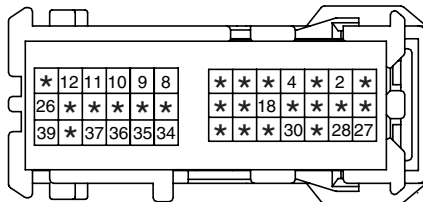

KET\_LIF0409\_39F\_W

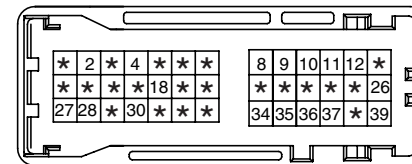

KET\_LIF0409\_39M\_W\_DR

# HARNES CONNECTOR

## HARNES CONNECTOR (3)

CC-3

**FD11**

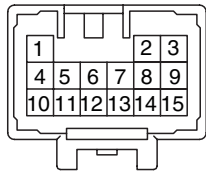

KET\_090III\_15M\_W

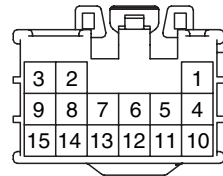

KET\_090III\_15F\_W

**FD12**

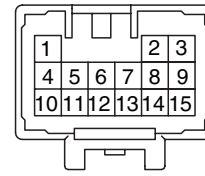

KET\_090III\_15M\_W

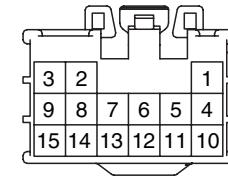

KET\_090III\_15F\_W

**FF01**

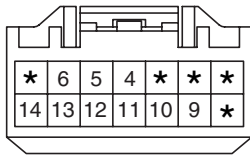

AMP\_090III\_14F\_W

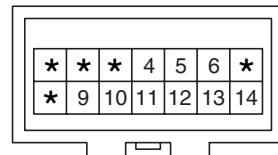

AMP\_090III\_14M\_W

**FF02**

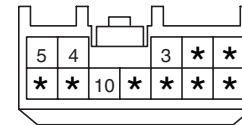

AMP\_090III\_12F\_Br

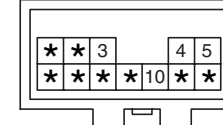

AMP\_090III\_12M\_Br

**FR11**

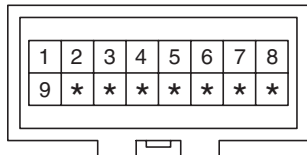

AMP\_090III\_16M\_W

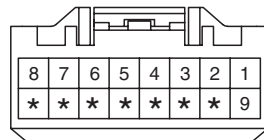

AMP\_090III\_16F\_W

**FR12**

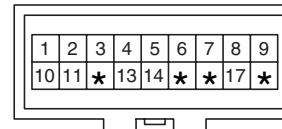

AMP\_090III\_18M\_W

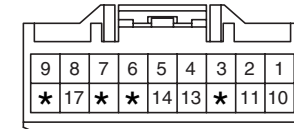

AMP\_090III\_18F\_W

**FR13**

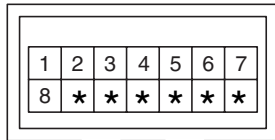

AMP\_090III\_14M\_W

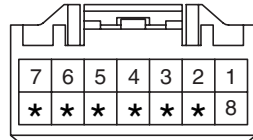

AMP\_090III\_14F\_W

**FR14**

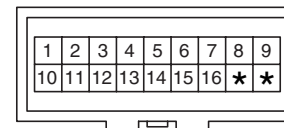

AMP\_090III\_18M\_L

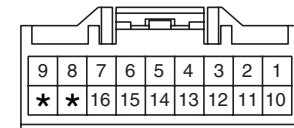

AMP\_090III\_18F\_L

**FS01**

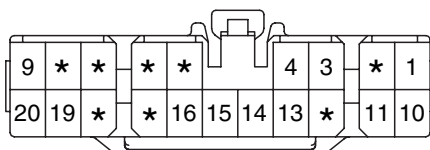

KET\_090II\_20F\_W

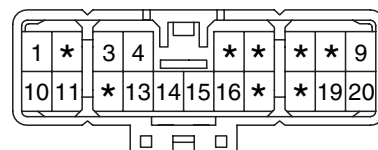

KET\_090II\_20M\_W

**FS02**

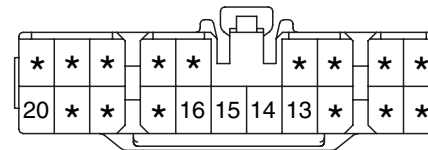

KET\_090II\_20F\_W

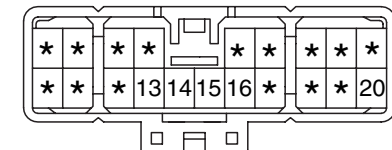

KET\_090II\_20M\_W

# HARNESS CONNECTOR

## HARNESS CONNECTOR (4)

CC-4

**MA11**

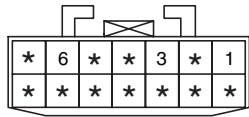

AMP\_MQS\_14F\_Y

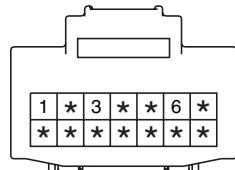

AMP\_MQS\_14M\_Y

**MF11**

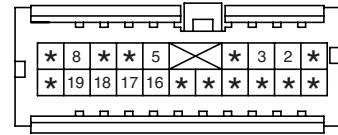

AMP\_040III\_20F\_BR

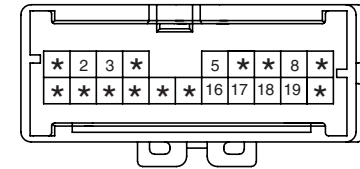

AMP\_040III\_20M\_BR

**MF21**

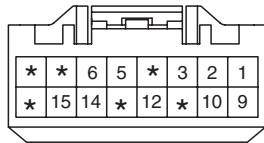

AMP\_090III\_16F\_W

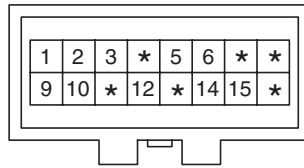

AMP\_090III\_16M\_W

**MF31**

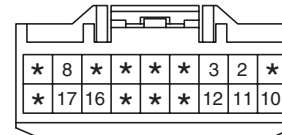

AMP\_090III\_18F\_Y

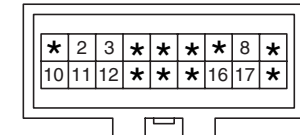

AMP\_090III\_18M\_Y

**MF71**

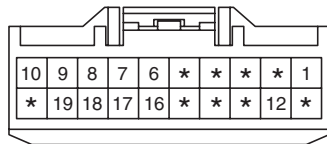

AMP\_090III\_20F\_BR

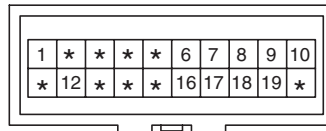

AMP\_090III\_20M\_BR

**MF81**

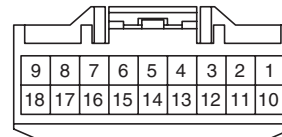

AMP\_090III\_18F\_Y

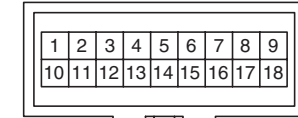

AMP\_090III\_18M\_Y

**MF91**

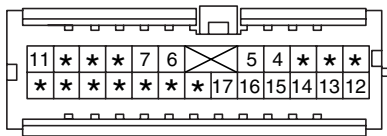

AMP\_040III\_24F\_W

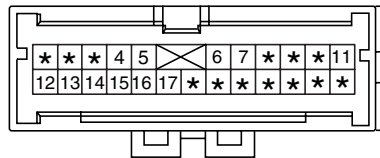

AMP\_040III\_24M\_W

**MFA1**

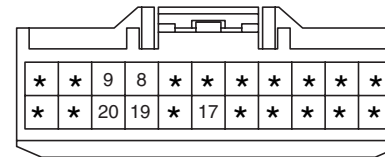

AMP\_090III\_22F\_R

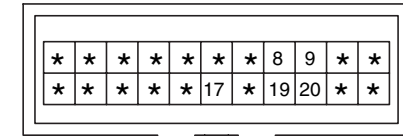

AMP\_090III\_22M\_R

**MFB1**

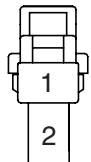

KET\_250DL\_02F\_W

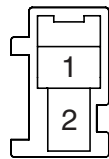

KET\_250DL\_02M\_W

**BLANK**

**SS01**

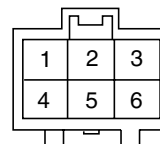

KET\_250D/L\_06M

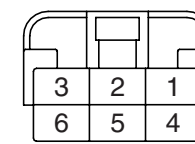

KET\_250D/L\_06F

**SS02/SS03**

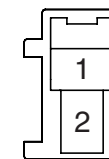

KET\_250D/L\_02M



KET\_250D/L\_02F

ENGINE COMPARTMENT JUNCTION BLOCK (1)

JC01(GSL 2.7L)

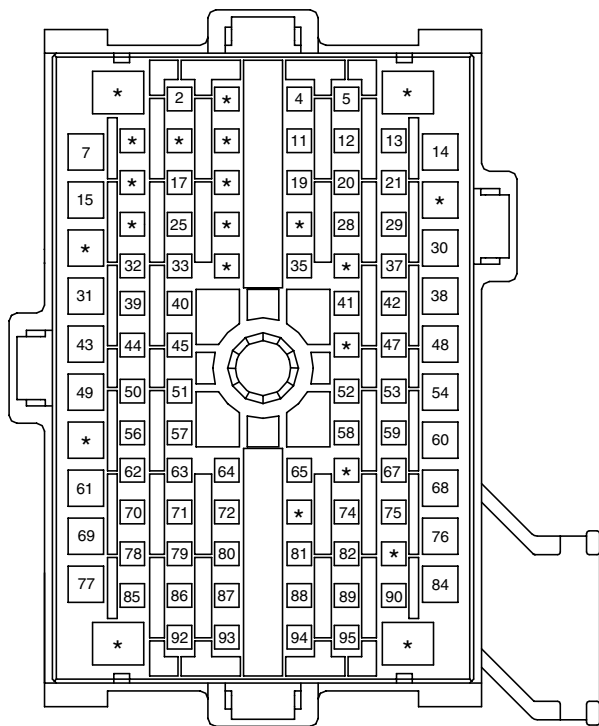

AMP\_MULBOX\_96F\_B

JC01(GSL 3.3L/3.8L)

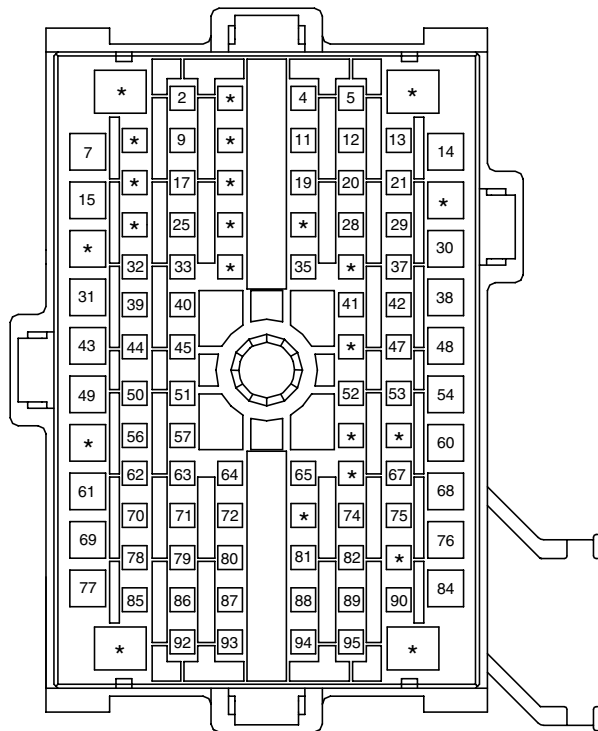

AMP\_MULBOX\_96F\_B

JC01(DSL)

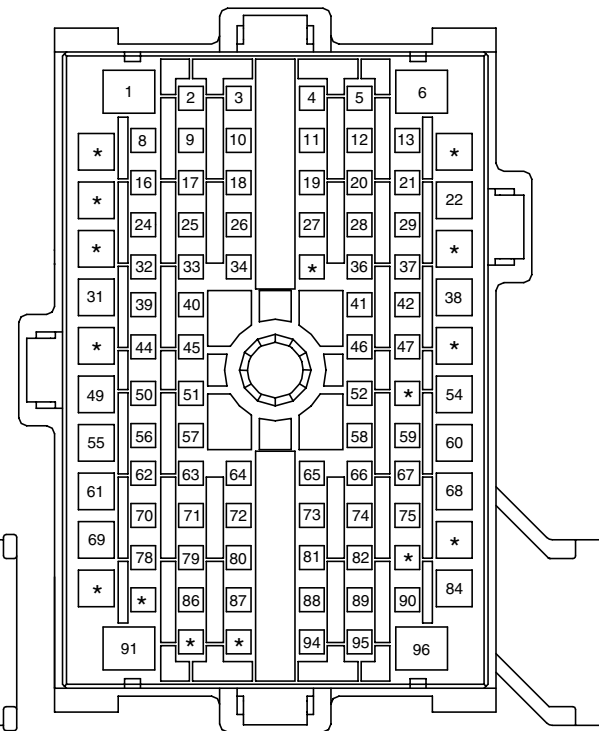

AMP\_MULBOX\_96F\_B



# ENGINE COMPARTMENT JUNCTION BLOCK

## ENGINE COMPARTMENT JUNCTION BLOCK (2)

CC-6

JE01

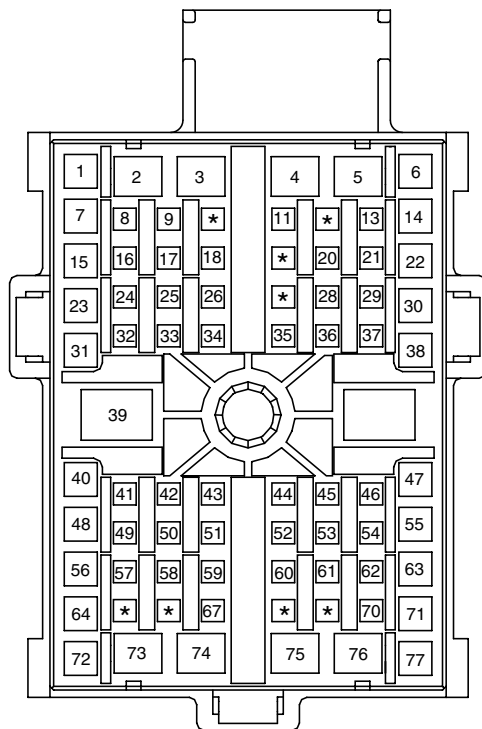

AMP\_MULBOX\_77F\_B

JE02

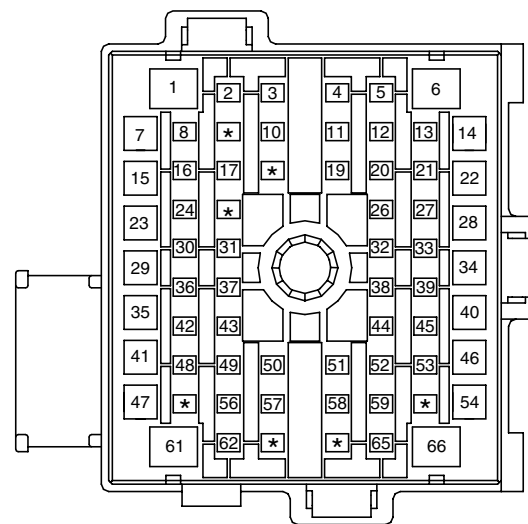

AMP\_MULBOX\_66F\_B\_C

**PASSENGER COMPARTMENT JUNCTION BLOCK** EA5977DF

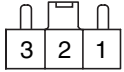
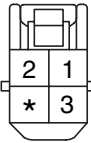
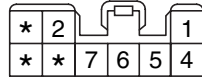
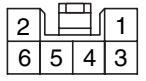
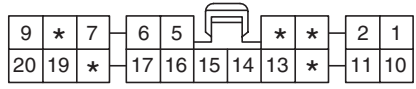
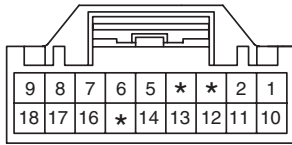
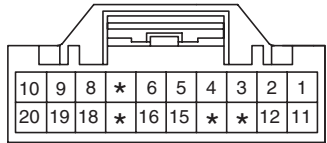
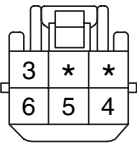
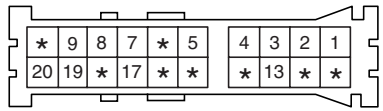
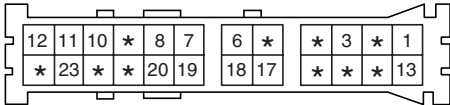
PASSENGER COMPARTMENT JUNCTION BLOCK (1)		CC-7
<p><b>I/P-A</b></p>  <p>SUM_312_03F_W</p>	<p><b>I/P-B</b></p>  <p>SUM_187_04F_W_1</p>	<p><b>I/P-C</b></p>  <p>SUM_090_09F_W</p>
<p><b>I/P-D</b></p>  <p>YAZ_312187_06F_W</p>	<p><b>I/P-E</b></p>  <p>SUM_090_20F_W</p>	<p><b>I/P-F</b></p>  <p>YZA_0409_18F_W</p>
<p><b>I/P-G</b></p>  <p>SUM_0409_20F_W</p>	<p><b>I/P-H</b></p>  <p>SUM_187_06F_W_1</p>	<p><b>I/P-J</b></p>  <p>YZA_LIF090_20F_W</p>
<p><b>I/P-K</b></p>  <p>YAZ_LIF090_24F_W</p>	<p><b>BLANK</b></p>	<p><b>BLANK</b></p>

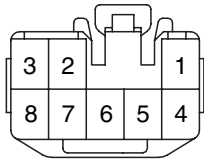
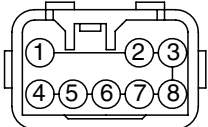
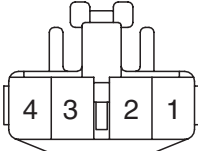
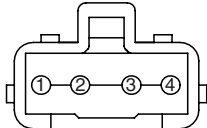
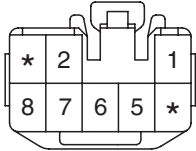
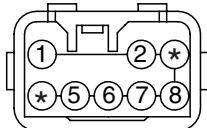
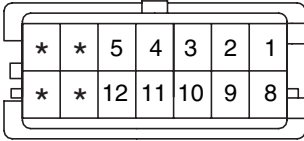
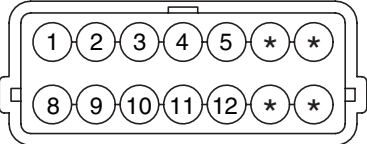
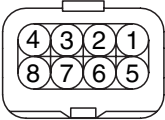
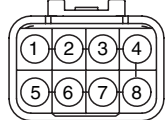
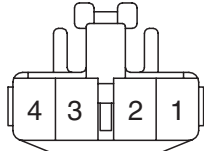
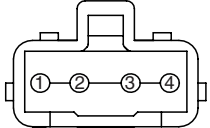
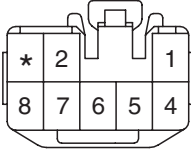
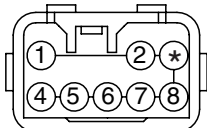
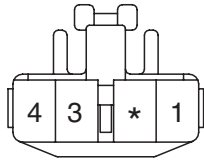
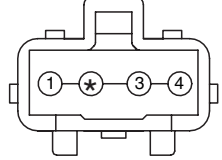
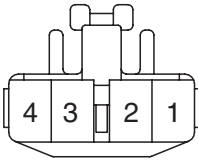
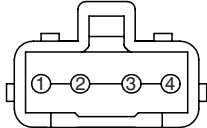
JOINT CONNECTOR (1)		CC-8
<p><b>D-1</b></p>  <p>KET_090III_08F_W</p>  <p>KET_090II_08M_JC</p>	<p><b>D-2</b></p>  <p>KET_090III_04F_W</p>  <p>KET_090II_04M_JC</p>	
<p><b>BLANK</b></p>	<p><b>E-1</b></p>  <p>KET_090III_08F_W</p>  <p>KET_090II_08M_JC</p>	
<p><b>E-3</b></p>  <p>KET_070_14F_W_JCH</p>  <p>KET_070_14M_W_JCH</p>	<p><b>E-4</b></p>  <p>KET_090IWP_08F_B_JCH</p>  <p>KET_090IWP_08M_B_JCH</p>	
<p><b>F-1</b></p>  <p>KET_090III_04F_W</p>  <p>KET_090III_04M_C</p>	<p><b>F-2</b></p>  <p>KET_090III_08F_W</p>  <p>KET_090III_08M_C</p>	
<p><b>F-3</b></p>  <p>KET_090III_04F_W</p>  <p>KET_090II_4P_CAP</p>	<p><b>F-4</b></p>  <p>KET_090III_04F_W</p>  <p>KET_090III_04M_C</p>	

# JOINT CONNECTOR

## JOINT CONNECTOR (2)

CC-9

**F-5**

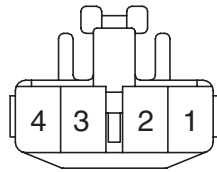

KET\_090III\_04F\_W

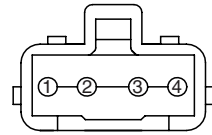

KET\_090III\_04M\_C

**BLANK**

**M-1**

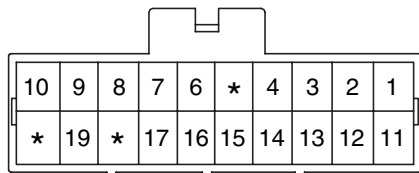

KET\_090III\_20F\_B\_JCH

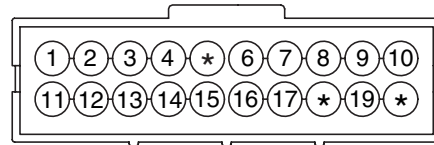

KET\_090III\_20P\_CAP

**M-2**

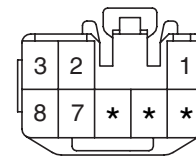

KET\_090III\_08F\_W

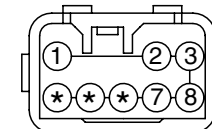

KET\_090III\_08M\_C

**M-3**

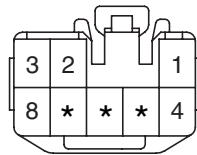

KET\_090III\_08F\_W

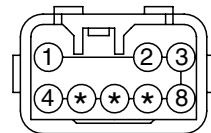

KET\_090III\_08M\_C

**M-5**

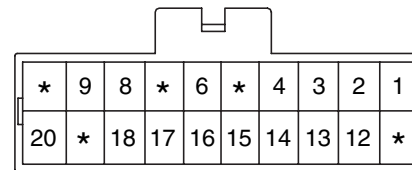

KET\_090III\_20F\_B\_JCH

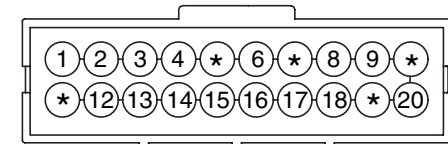

KET\_090III\_20P\_CAP

**M-6**

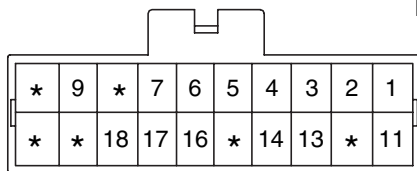

KET\_090III\_20F\_B\_JCH

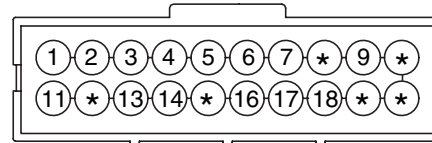

KET\_090III\_20P\_CAP

**M-7**

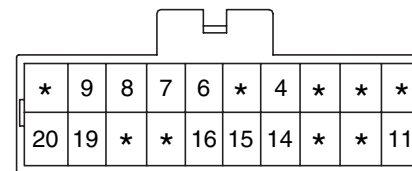

KET\_090III\_20F\_B\_JCH

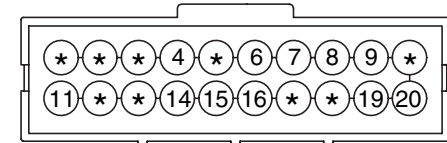

KET\_090III\_20P\_CAP

**M-9**

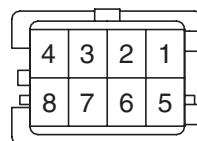

KET\_070\_08F\_W\_JCH

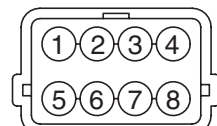

KET\_070\_08M\_W\_JCH

**M-10**

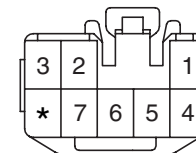

KET\_090III\_08F\_W

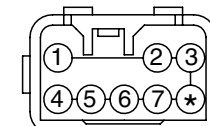

KET\_090III\_08M\_C

# JOINT CONNECTOR

## JOINT CONNECTOR (3)

CC-10

**M-11**

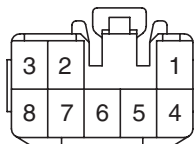

KET\_090III\_08F\_W

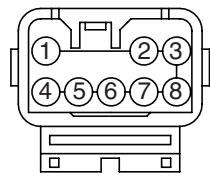

MG 643309\_2

**M-12**

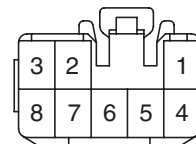

KET\_090III\_08F\_W

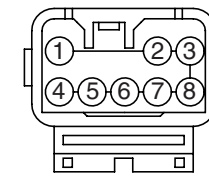

MG 643309\_2

**M-14**

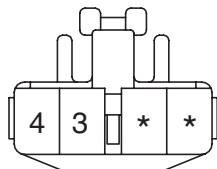

KET\_090III\_04F\_W

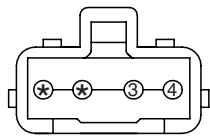

KET\_090III\_04M\_C

**M-17**

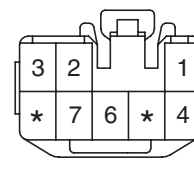

KET\_090III\_08F\_W

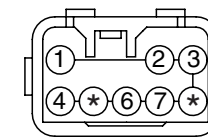

KET\_090II\_08M\_C

**R-1**

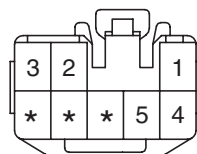

KET\_090III\_08F\_W

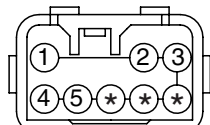

KET\_090III\_08M\_JC

**R-2**

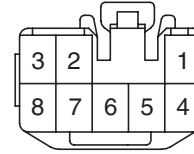

KET\_090III\_08F\_W

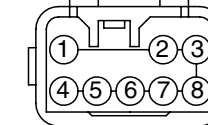

KET\_090II\_08M\_JC

**S-1**

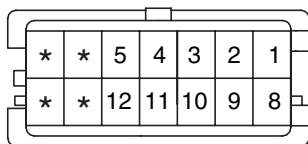

KET\_PCB\_14F

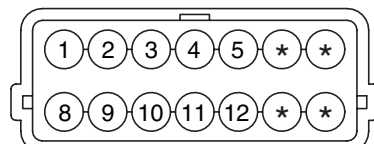

KET\_PCB\_14P\_JCH\_CAP

**BLANK**

MAIN HARNESS (1)

HL-1

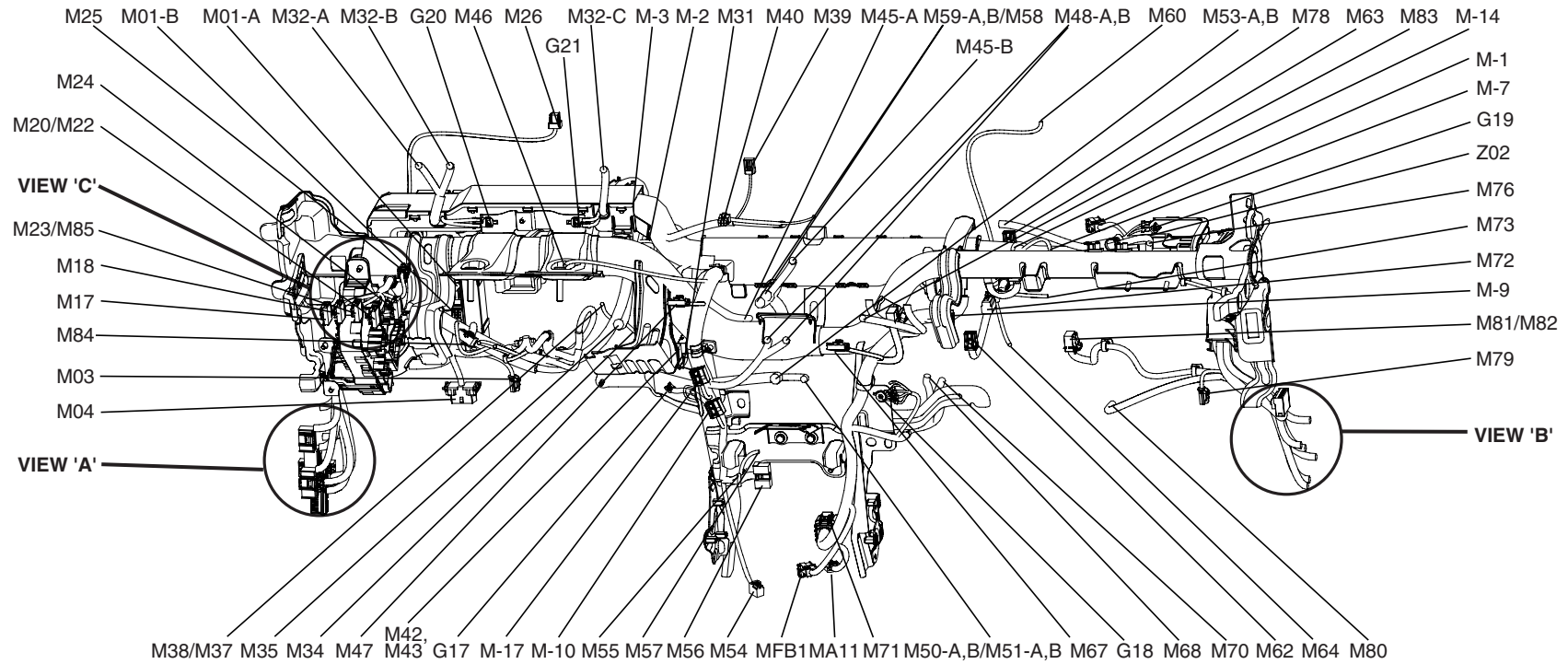

VIEW 'A'

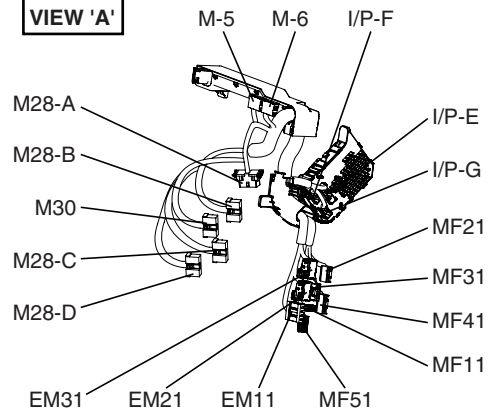

VIEW 'B'

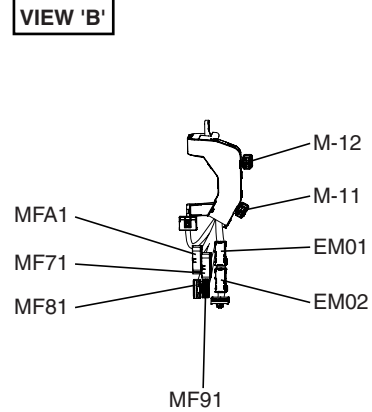

VIEW 'C'

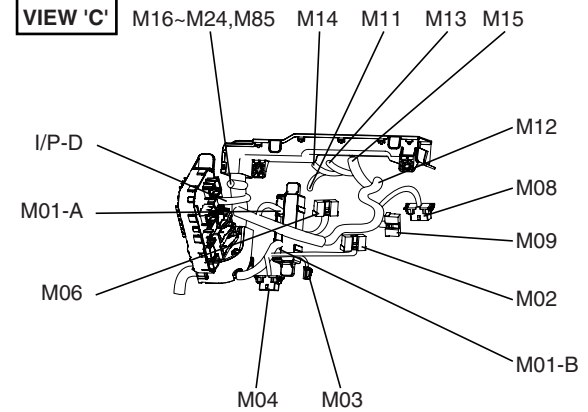

## MAIN HARNESS

### MAIN HARNESS (2)

HL-2

#### MAIN HARNESS

M01-A	ICM relay box	M51-A	A/C control module(Manual)	EM11	Connection with ENGINE FRONT harness
M01-B	ICM relay box	M51-B	A/C control module(Manual)	EM21	Connection with ENGINE FRONT harness
M02	Telescopic motor	M55	Front cigarette lighter	EM31	Connection with ENGINE FRONT harness
M03	Left foot lamp	M56	Rear curtain module	EM41	Connection with ENGINE FRONT harness
M04	Data link connector	M58	Audio	MA11	Connection with AIR BAG harness
M06	Tilt motor	M60	Security indicator	MF11	Connection with FLOOR harness
M08	Door warning switch	M62	Passenger temperature actuator(LHD)	MF21	Connection with FLOOR harness
M11	Tilt & Telescopic switch	M62R	Passenger temperature actuator(RHD)	MF31	Connection with FLOOR harness
M12	Multifunction switch	M63	Intake actuator(LHD)	MF71	Connection with FLOOR harness
M13	Driver air bag	M63R	Intake actuator(RHD)	MF81	Connection with FLOOR harness
M14	Multifunction switch(Audio remocon)	M64	Glove box switch	MF91	Connection with FLOOR harness
M15	Steering angle sensor	M67	Active incar & Humidity sensor	MFA1	Connection with FLOOR harness
M16	Head lamp leveling switch(Manual)	M68	Evaporator sensor	MFB1	Connection with FLOOR harness
M18	Rear fog lamp switch	M70	Water temperature sensor	I/P-A	Connection with PASSENGER COMPARTMENT JUNCTION BLOCK(RHD)
M22	ESP switch	M71	SRS control module	I/P-B	Connection with PASSENGER COMPARTMENT JUNCTION BLOCK(RHD)
M24	Rheostat	M72	Trunk main switch	I/P-C	Connection with PASSENGER COMPARTMENT JUNCTION BLOCK(RHD)
M25	Back warning buzzer	M73	Glove box lamp	I/P-D	Connection with PASSENGER COMPARTMENT JUNCTION BLOCK
M26	Auto light & Photo sensor	M75	Air bag cut off switch	I/P-E	Connection with PASSENGER COMPARTMENT JUNCTION BLOCK
M28-A	BCM	M76	ATM key lock control module	I/P-F	Connection with PASSENGER COMPARTMENT JUNCTION BLOCK
M28-B	BCM	M78	Passenger air bag	I/P-G	Connection with PASSENGER COMPARTMENT JUNCTION BLOCK
M28-C	BCM	M79	Right foot lamp	G17	Ground
M28-D	BCM	M80	Blower motor(LHD)	G18	Ground
M30	Tilt & Telescopic module	M80R	Blower motor(RHD)	G19	Ground
M31	PTC heater(DSL)	M81	Blower resistor	G20	Ground
M32-A	Instrument cluster	M82	FE(Field Effect) Transister	G21	Ground
M32-B	Instrument cluster	M84	Pre-Excitation resistor(DSL)		
M32-C	Instrument cluster	M-1	Joint connector		
M34	Immobilizer module	M-2	Joint connector		
M35	Ignition switch	M-3	Joint connector		
M38	Key solenoid	M-5	Joint connector		
M39	Center speaker	M-6	Joint connector		
M40	Digital clock & Passenger seat belt indicator	M-7	Joint connector		
M42	Driver temperature actuator(LHD)	M-9	Joint connector		
M42R	Driver temperature actuator(RHD)	M-10	Joint connector		
M43	Mode actuator(LHD)	M-11	Joint connector		
M43R	Mode actuator(RHD)	M-12	Joint connector		
M46	Trip mode reset	M-14	Joint connector		
M47	Hazard switch	M-17	Joint connector		
M50-A	A/C control module(Auto)	EM01	Connection with ENGINE ROOM harness		
M50-B	A/C control module(Auto)	EM02	Connection with ENGINE ROOM harness		
		EM03	Connection with ENGINE ROOM harness(DSL)		

ENGINE HARNESS (1)

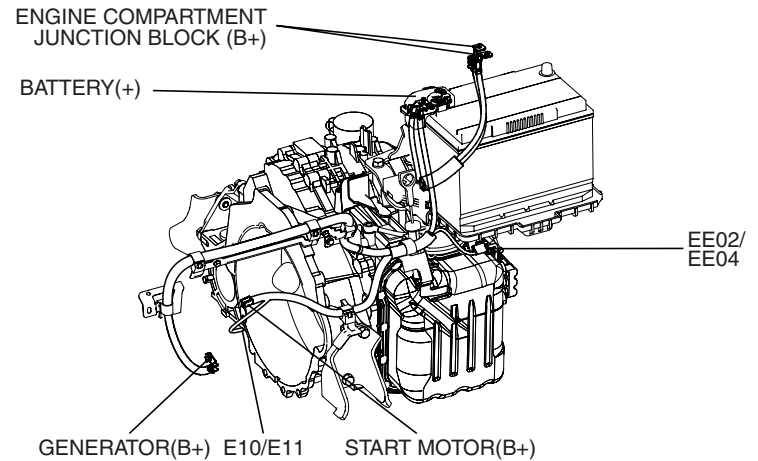
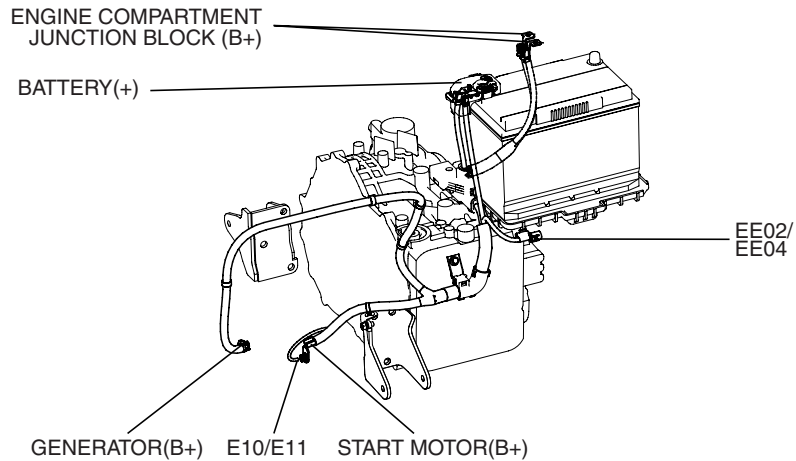
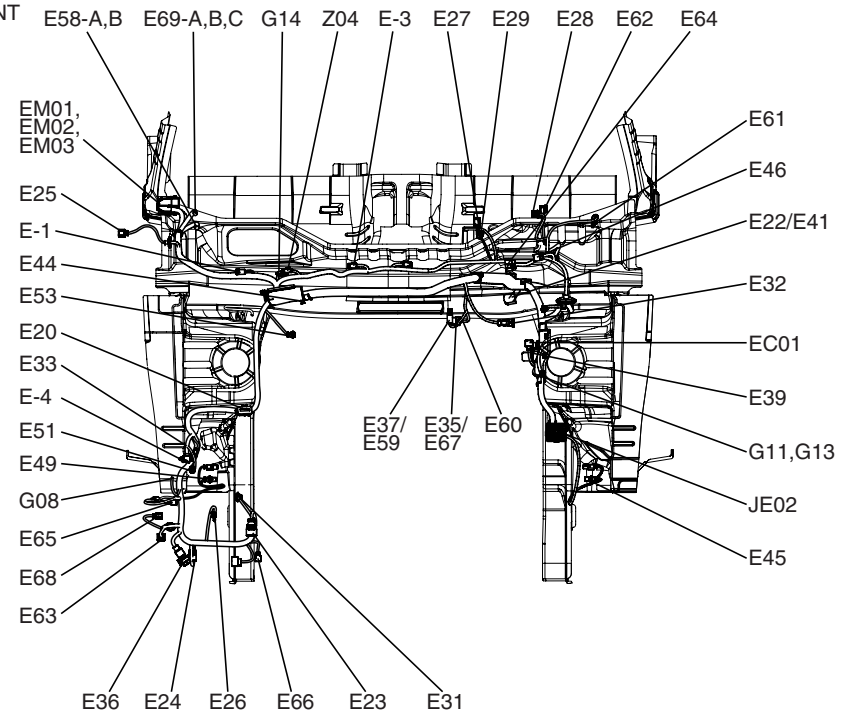
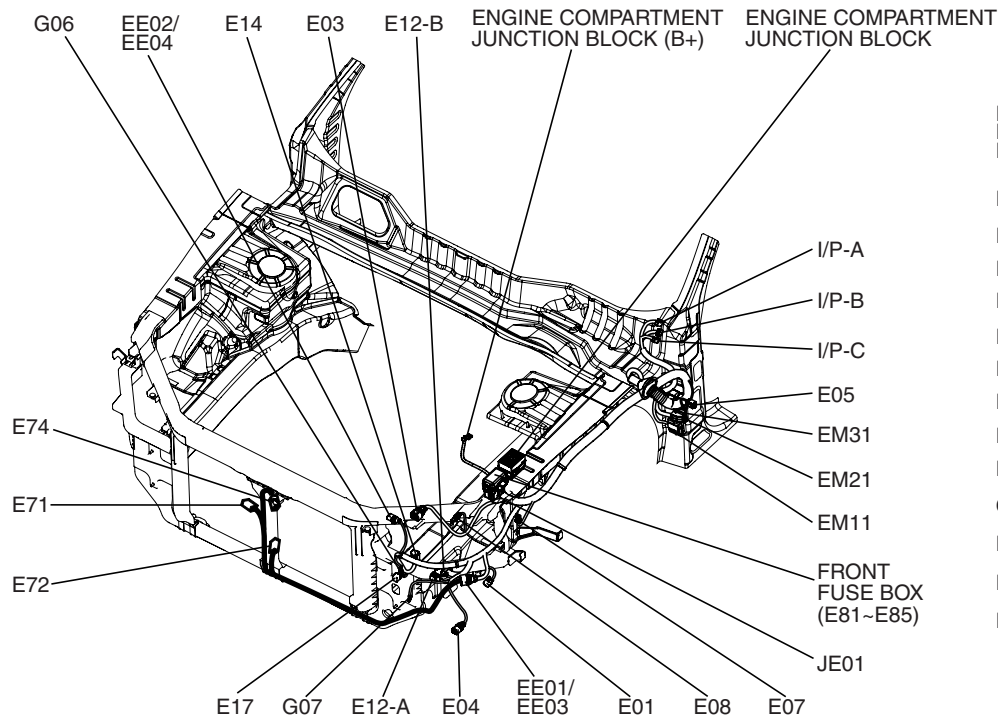



## ENGINE HARNESS

### ENGINE HARNESS (2)

HL-4

#### ENGINE FRONT HARNESS

E01 Left horn  
E03 Left head lamp  
E04 Left front fog lamp  
E05 Left side repeater lamp  
E07 External buzzer  
E08 Left head lamp leveling actuator  
E12-A Cooling fan controller  
E12-B Cooling fan controller  
E14 Cooling fan relay  
E17 Driver front impact sensor  
EE01 Connection with ENGINE FRONT END MODULE harness  
EE02 Connection with BATTERY harness(GSL)  
EE04 Connection with BATTERY harness(DSL)  
EM11 Connection with MAIN harness  
EM21 Connection with MAIN harness  
EM31 Connection with MAIN harness  
EM41 Connection with MAIN harness  
I/P-A Connection with PASSENGER COMPARTMENT JUNCTION BLOCK(LHD)  
I/P-B Connection with PASSENGER COMPARTMENT JUNCTION BLOCK(LHD)  
I/P-C Connection with PASSENGER COMPARTMENT JUNCTION BLOCK(LHD)  
JE01 Connection with ENGINE COMPARTMENT JUNCTION BLOCK  
G06 Ground  
G07 Ground

#### BATTERY HARNESS

E10 Start solenoid(GSL)  
E11 Start solenoid(DSL)  
EE02 Connection with ENGINE FRONT harness(GSL)  
EE04 Connection with ENGINE FRONT harness(DSL)

#### ENGINE FRONT END MODULE HARNESS

E71 Right horn  
E72 AQS & Ambient sensor  
EE01 Connection with ENGINE FRONT harness

#### ENGINE ROOM HARNESS

E20 Multipurpose check connector  
E22 ABS control module  
E23 Right head lamp  
E24 Right front fog lamp  
E25 Right side repeater lamp

E26 Right head lamp leveling actuator  
E29 Accel position sensor  
E31 A/C pressure transducer  
E32 Brake oil level sensor  
E33 Burglar alarm horn  
E36 HID relay  
E37 Fuel filter switch(LHD, DSL)  
E37R Fuel filter switch(RHD, DSL)  
E41 ESP module  
E44 VGT actuator(DSL)  
E45 Left front wheel sensor  
E46 Windshield defogger  
E49 Right front wheel sensor  
E51 Hood switch  
E53 Differential temperature sensor  
E57 Right front wheel sensor(W/O ABS/ESP)  
E60 Fuel filter heater(DSL)  
E61 Parking brake switch  
E62 Stop lamp switch  
E63 Washer motor  
E64 Wiper motor  
E65 Washer fluid level sensor  
E66 Passenger front impact sensor  
E67 Fuel filter warning sensor(DSL)  
E68 Head lamp washer motor  
E69-A TCM(DSL)  
E69-B TCM(DSL)  
E69-C TCM(DSL)  
E81 Glow plug relay(DSL)  
E82 PTC heater relay #1(DSL)  
E83 PTC heater relay #2(DSL)  
E84 PTC heater relay #3(DSL)  
E85 Fuel filter relay(DSL)  
E-1 Joint connector  
E-3 Joint connector  
E-4 Joint connector  
EC01 Connection with CONTROL harness  
EM01 Connection with MAIN harness  
EM02 Connection with MAIN harness  
EM03 Connection with MAIN harness(DSL)  
JE02 Connection with ENGINE COMPARTMENT JUNCTION BLOCK  
G08 Ground  
G11 Ground(DSL)  
G13 Ground(GSL)  
G14 Ground

FLOOR HARNESS (1)

HL-5

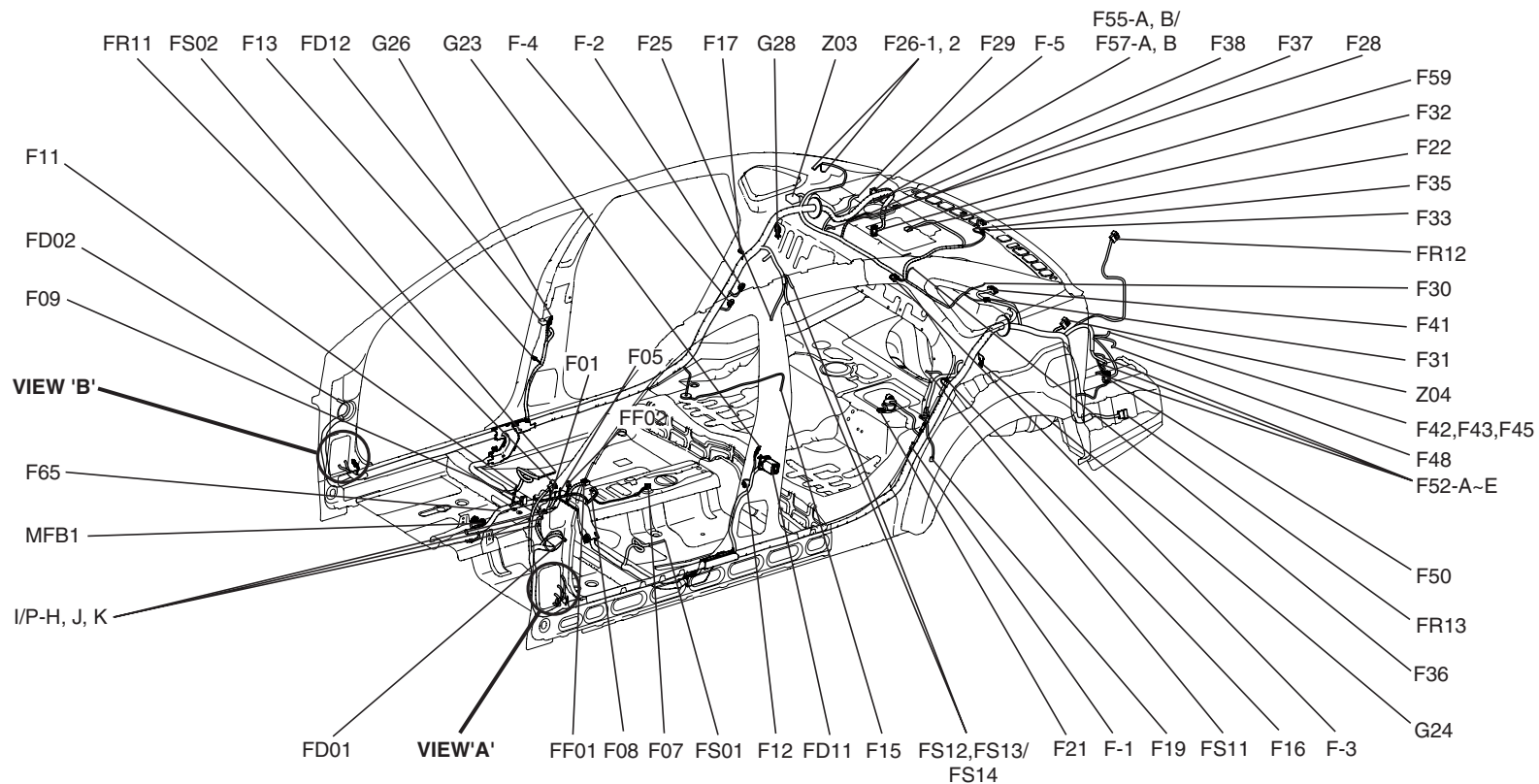

VIEW 'A'

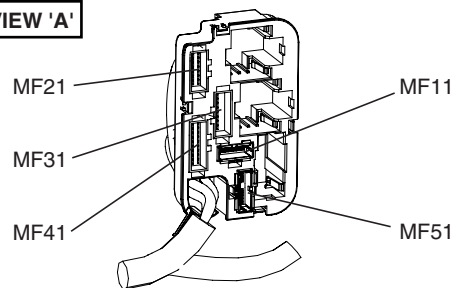

VIEW 'B'

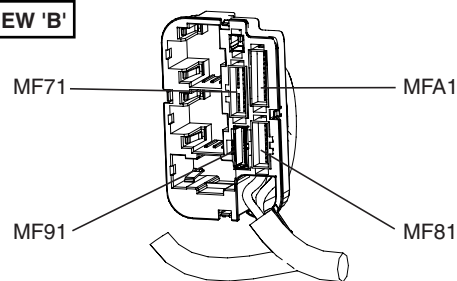

CONSOLE EXT. HARNESS

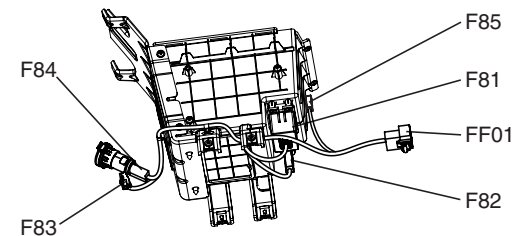

## FLOOR HARNESS

### FLOOR HARNESS (2)

HL-6

#### FLOOR HARNESS

F01 Driver seat warmer switch  
F08 Yaw rate sensor  
F09 Sport mode switch  
F11 Passenger seat warmer switch  
F12 Left front door switch  
F13 Right front door switch  
F15 Auto head lamp leveling sensor  
F16 Left rear door switch  
F17 Right rear door switch  
F19 Left rear wheel sensor  
F21 Fuel sender & Fuel pump motor  
F22 High-mounted stop lamp  
F25 Right rear wheel sensor  
F26-1 Rear window defogger(+)  
F29 Glass antenna module  
F33 Rear curtain motor  
F35 Trunk room lamp  
F36 Woofer speaker  
F48 Fuel lid opener actuator  
F49 Back warning control module  
F57-A Premium amp  
F57-B Premium amp  
F65 Exhaust gas temperature sensor #2  
F-1 Joint connector  
F-2 Joint connector  
F-3 Joint connector  
F-4 Joint connector  
F-5 Joint connector  
FD01 Connection with LEFT FRONT DOOR harness  
FD02 Connection with RIGHT FRONT DOOR harness  
FD11 Connection with LEFT REAR DOOR harness  
FD12 Connection with RIGHT REAR DOOR harness  
FF01 Connection with CONSOLE EXT. harness  
FF02 Connection with CONSOLE UPR CENTER harness  
FR11 Connection with ROOF harness  
FR12 Connection with TRUNK LID harness

FR13 Connection with TRUNK ROOM harness  
FR14 Connection with BACK WARNING EXT. harness  
FS01 Connection with DRIVER POWER SEAT harness  
FS02 Connection with PASSENGER POWER SEAT harness  
MF11 Connection with MAIN harness  
MF21 Connection with MAIN harness  
MF31 Connection with MAIN harness  
MF71 Connection with MAIN harness  
MF81 Connection with MAIN harness  
MF91 Connection with MAIN harness  
MFA1 Connection with MAIN harness  
MFB1 Connection with MAIN harness  
I/P-H Connection with PASSENGER COMPARTMENT JUNCTION BLOCK  
I/P-J Connection with PASSENGER COMPARTMENT JUNCTION BLOCK  
I/P-K Connection with PASSENGER COMPARTMENT JUNCTION BLOCK  
G23 Ground  
G24 Ground  
G26 Ground  
G28 Ground  
Z04 Diode

#### CONSOLE EXT. HARNESS

F82 Front accessory socket  
F83 RF receiver  
F84 Rear power outlet  
F85 Tray bulb  
FF01 Connection with FLOOR harness

#### CONSOLE UPR CENTER HARNESS

F05 Rear curtain switch  
FF02 Connection with FLOOR harness

CONTROL HARNESS (1)

HL-7

GSL 2.7L

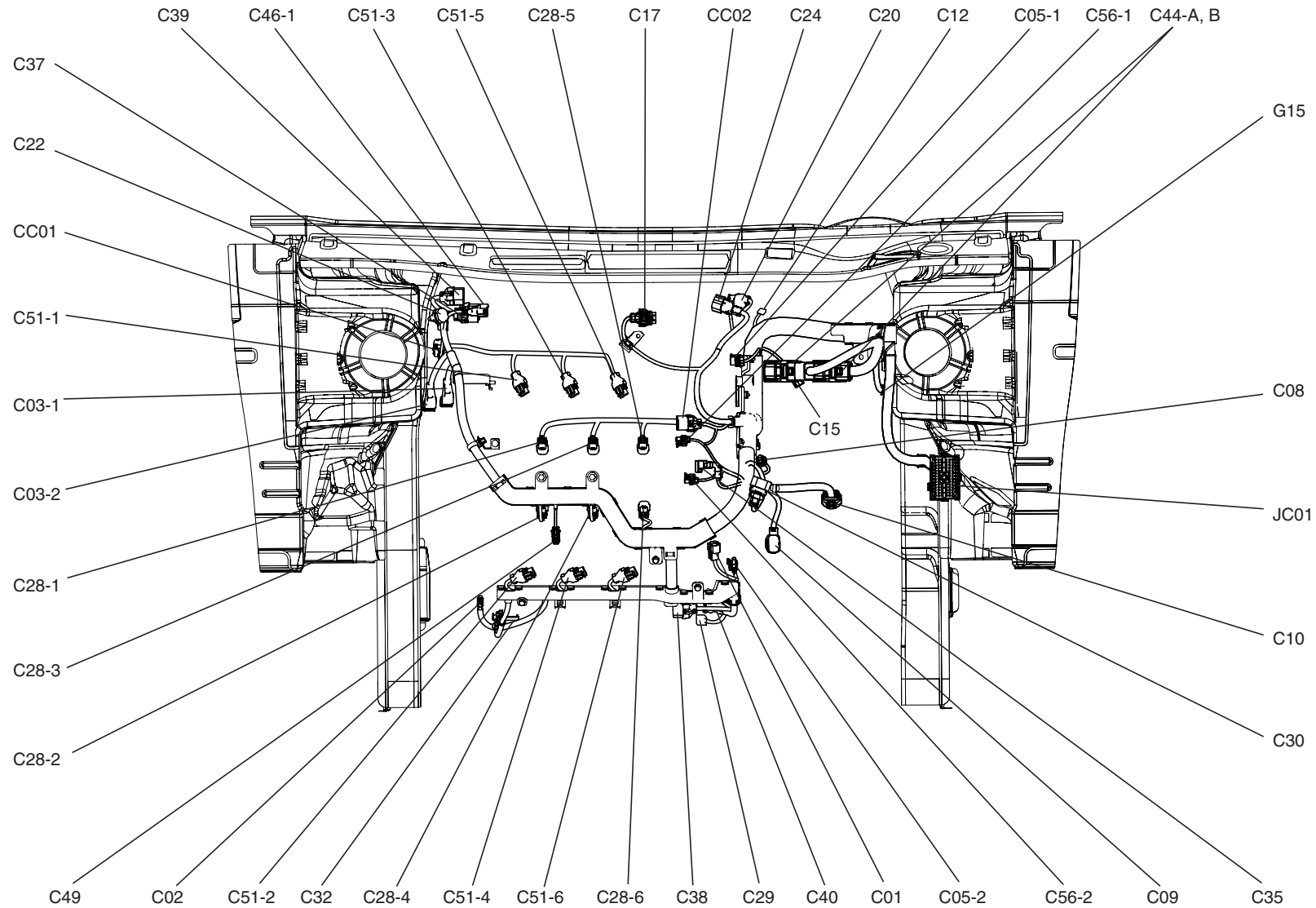

## CONTROL HARNESS

### CONTROL HARNESS (2)

HL-8

#### CONTROL HARNESS(GSL 2.7L)

C01 Engine coolant temperature sensor & Sender  
C02 A/C compressor  
C03-1 Knock sensor #1  
C03-2 Knock sensor #2  
C05-1 Camshaft position sensor #1  
C05-2 Camshaft position sensor #2  
C08 Pulse generator 'A'  
C09 Transaxle range switch  
C10 ATM solenoid  
C11 Oil pressure switch  
C12 Vehicle speed sensor  
C15 Pulse generator 'B'  
C17 Manifold absolute pressure sensor  
C20 Canister purge valve  
C22 Power steering pressure sensor  
C24 ETC motor & Throttle position sensor  
C28-2 Injector #2  
C28-4 Injector #4  
C28-6 Injector #6  
C29 Crankshaft position sensor  
C30 Mass air flow sensor  
C32 Generator  
C35 Oil temperature sensor  
C37 O<sub>2</sub> sensor #1(B1/S1)  
C38 O<sub>2</sub> sensor #2(B2/S1)  
C39 O<sub>2</sub> sensor #3(B1/S2)  
C40 O<sub>2</sub> sensor #4(B2/S2)  
C44-A PCM  
C44-B PCM  
C46-1 Variable intake manifold valve #1  
C46-2 Variable intake manifold valve #2  
C49 Condenser  
C51-2 Ignition coil #2  
C51-4 Ignition coil #4  
C51-6 Ignition coil #6  
C56-1 Oil control valve #1  
C56-2 Oil control valve #2  
CC01 Connection with IGNITION COIL harness  
CC02 Connection with INJECTOR harness  
JC01 Connection with ENGINE COMPARTMENT JUNCTION BLOCK  
G15 Ground

#### IGNITION COIL HARNESS

C51-1 Ignition coil #1  
C51-3 Ignition coil #3  
C51-5 Ignition coil #5  
CC01 Connection with CONTROL harness

#### INJECTOR HARNESS

C28-1 Injector #1  
C28-3 Injector #3  
C28-5 Injector #5  
CC02 Connection with CONTROL harness

# CONTROL HARNESS

## CONTROL HARNESS (3)

HL-9

GSL 3.3L/3.8L

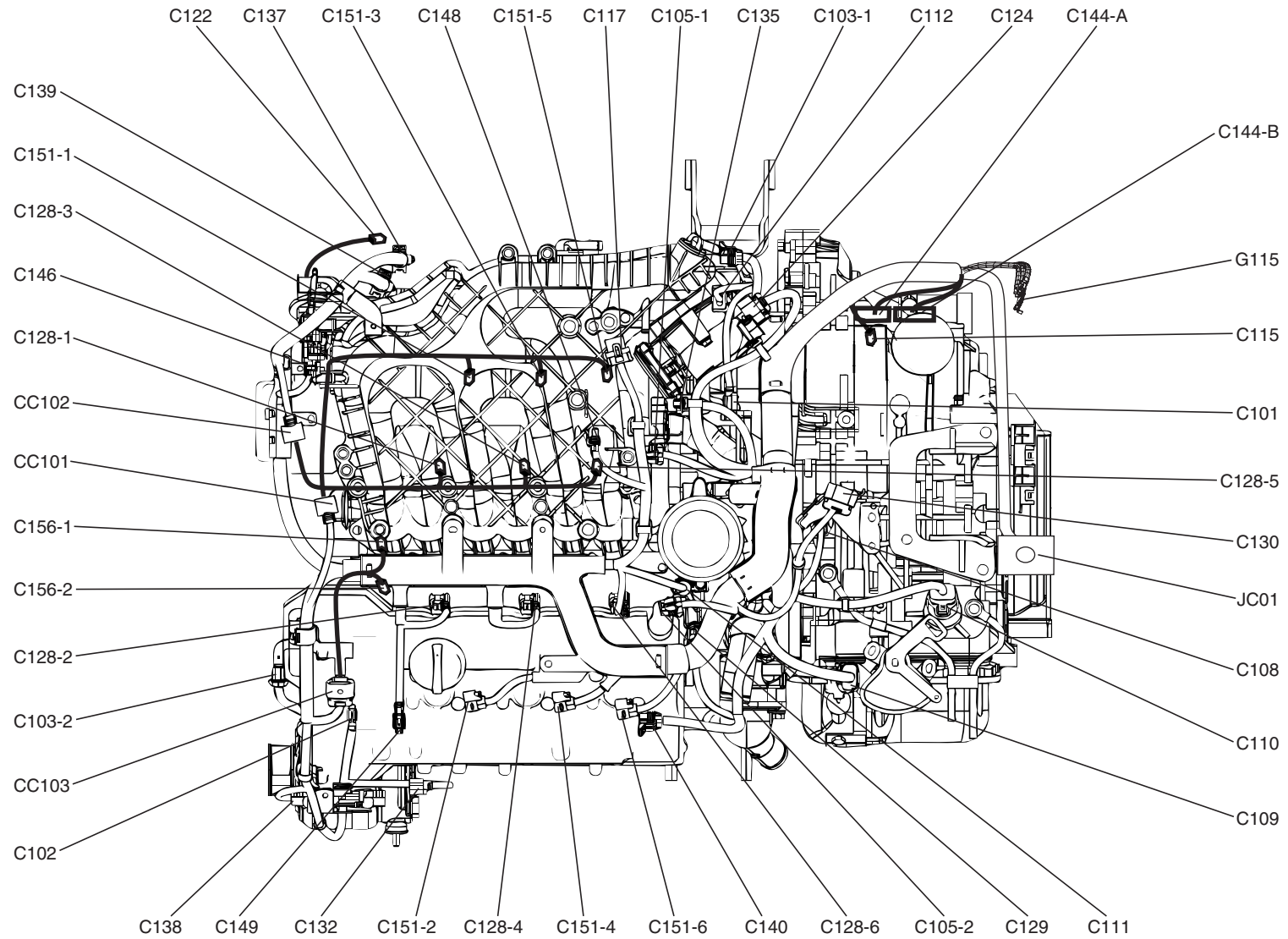

## CONTROL HARNESS

### CONTROL HARNESS (4)

HL-10

#### CONTROL HARNESS(GSL 3.3L/3.8L)

C101 Engine coolant temperature sensor & Sender  
C102 A/C compressor  
C103-1 Knock sensor #1  
C103-2 Knock sensor #2  
C105-1 Camshaft position sensor #1  
C105-2 Camshaft position sensor #2  
C108 Pulse generator 'A'  
C109 Transaxle range switch  
C110 ATM solenoid  
C111 Oil pressure switch  
C112 Vehicle speed sensor  
C115 Pulse generator 'B'  
C117 Manifold absolute pressure sensor  
C122 Power steering pressure sensor  
C124 ETC motor & Throttle position sensor  
C128-2 Injector #2  
C128-4 Injector #4  
C128-6 Injector #6  
C129 Crankshaft position sensor  
C130 Mass air flow sensor  
C132 Generator  
C135 Oil temperature sensor  
C137 O<sub>2</sub> sensor #1(B1/S1)  
C138 O<sub>2</sub> sensor #2(B2/S1)  
C139 O<sub>2</sub> sensor #3(B1/S2)  
C140 O<sub>2</sub> sensor #4(B2/S2)  
C144-A PCM  
C144-B PCM  
C146 Variable intake manifold valve  
C148 Purge control solenoid valve  
C149 Condenser  
C151-2 Ignition coil #2  
C151-4 Ignition coil #4  
C151-6 Ignition coil #6  
CC101 Connection with IGNITION COIL harness  
CC102 Connection with INJECTOR harness  
CC103 Connection with OIL CONTROL VALVE harness  
JC01 Connection with ENGINE COMPARTMENT JUNCTION BLOCK  
G115 Ground

#### IGNITION COIL HARNESS

C151-1 Ignition coil #1  
C151-3 Ignition coil #3  
C151-5 Ignition coil #5  
C155 Condenser  
CC101 Connection with CONTROL harness

#### INJECTOR HARNESS

C128-1 Injector #1  
C128-3 Injector #3  
C128-5 Injector #5  
CC102 Connection with CONTROL harness

#### OIL CONTROL VALVE HARNESS

C156-1 Oil control valve #1  
C156-2 Oil control valve #2  
CC103 Connection with CONTROL harness

# CONTROL HARNESS

## CONTROL HARNESS (5)

HL-11

**DIESEL**

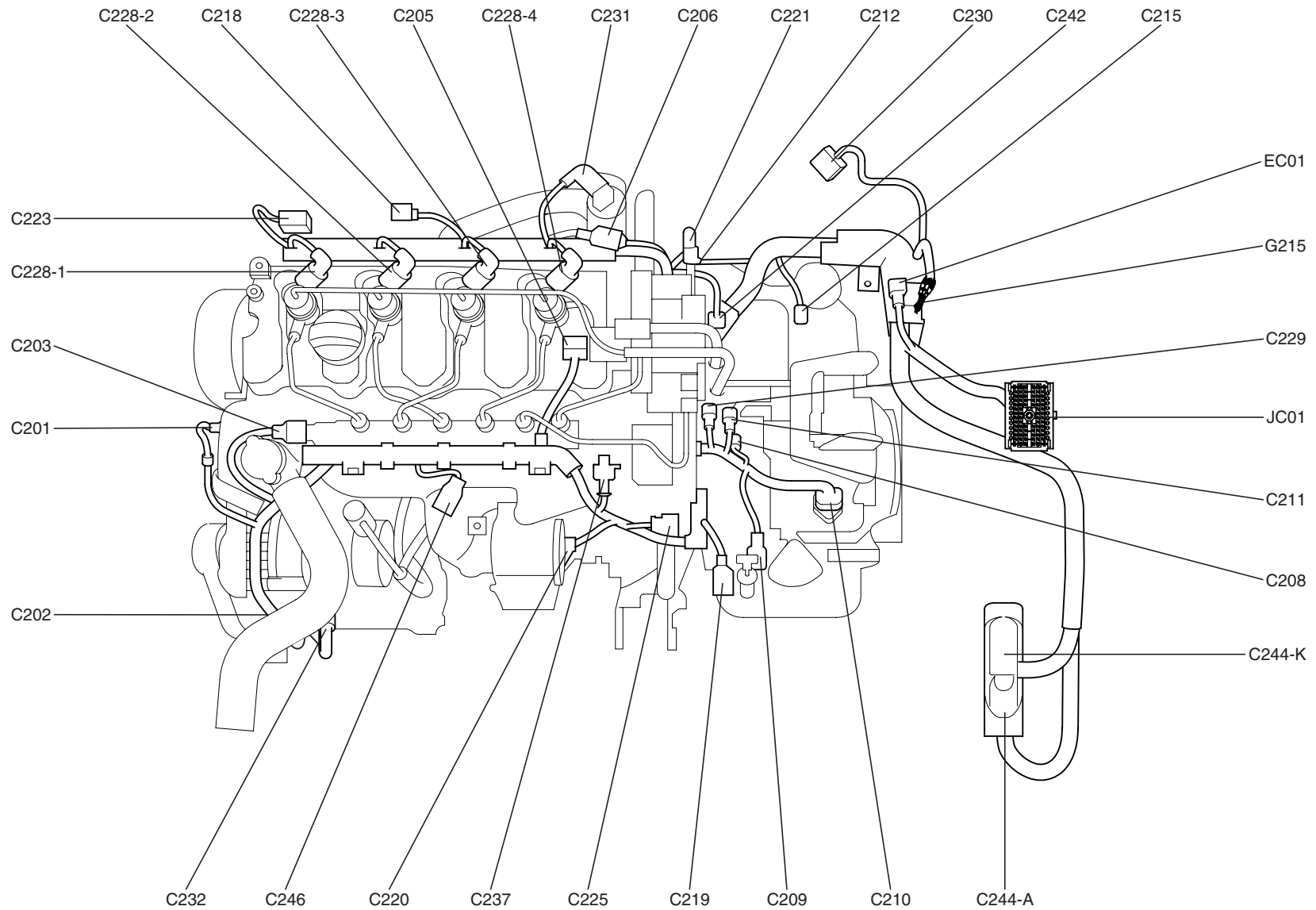



## CONTROL HARNESS

### CONTROL HARNESS (6)

HL-12

#### CONTROL HARNESS(DIESEL)

C201	Engine coolant temperature sensor & Sender
C202	A/C compressor
C203	Rail pressure sensor
C205	Camshaft position sensor
C206	Glow plug
C208	Pulse generator 'A'
C209	Transaxle range switch
C210	ATM solenoid
C211	Oil pressure switch
C212	Vehicle speed sensor
C215	Pulse generator 'B'
C218	Exhaust gas temperature sensor #1
C219	Boost pressure sensor
C220	Throttle control actuator
C221	Fuel metering unit
C223	Lambda sensor
C225	Variable swirl control actuator
C228-1	Injector #1
C228-2	Injector #2
C228-3	Injector #3
C228-4	Injector #4
C229	Crankshaft position sensor
C230	Air flow sensor
C231	EGR actuator
C232	Generator
C237	Fuel pressure regulating valve
C242	Fuel temperature sensor
C244-A	ECM
C244-K	ECM
EC01	Connection with ENGINE ROOM harness
JC01	Connection with ENGINE COMPARTMENT JUNCTION BLOCK
G215	Ground

DOOR HARNESS (1)

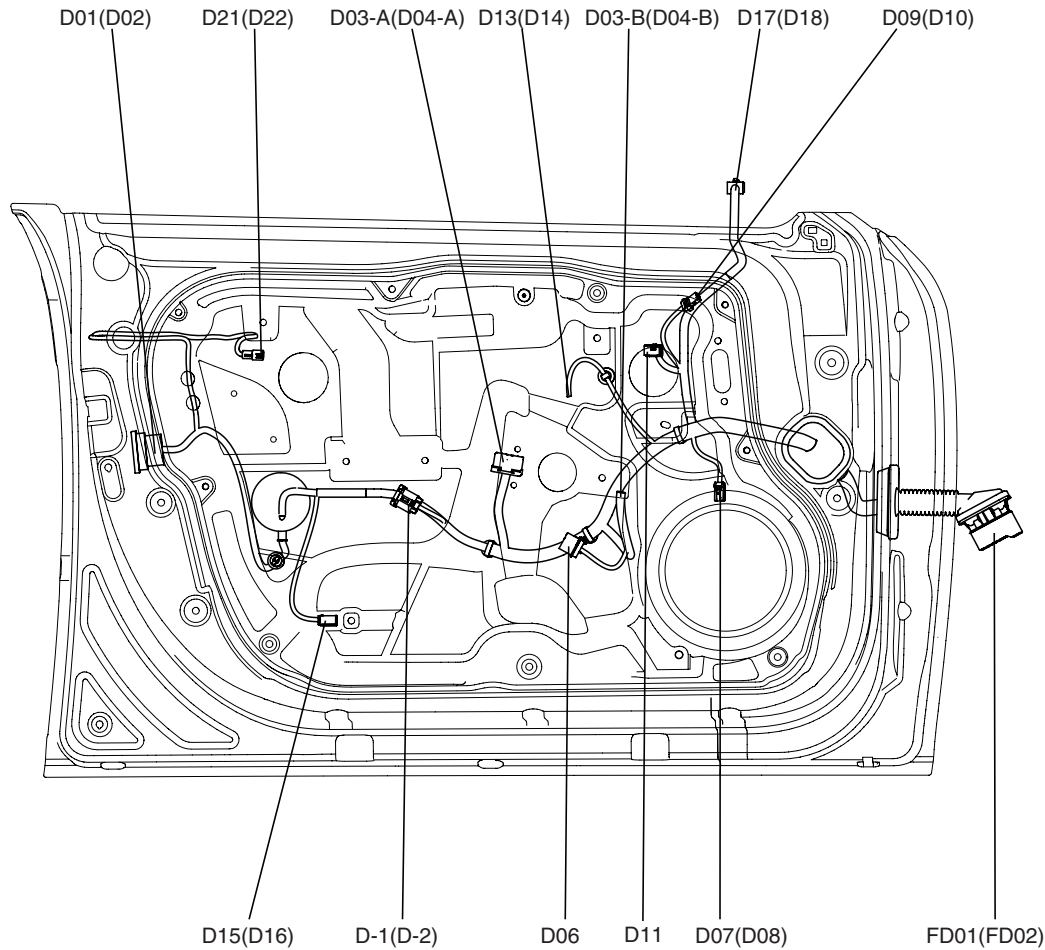

**LEFT FRONT DOOR HARNESS**

- D01 Left front door lock actuator(LHD)
- D01R Left front door lock actuator(RHD, W/O Dead lock)
- D03-A Power window main switch
- D03-B Power window main switch
- D06 Fuel lid opener & Trunk lid switch
- D07 Driver door speaker
- D09 Driver tweeter speaker
- D11 IMS switch
- D13 Left front safety window module
- D15 Driver door lamp
- D17 Left outside mirror & Mirror folding motor
- D25 Left front door lock actuator(RHD, With Dead lock)
- D-1 Joint connector
- FD01 Connection with FLOOR harness

**RIGHT FRONT DOOR HARNESS**

- D02 Right front door lock actuator(LHD)
- D02R Right front door lock actuator(RHD, W/O Dead lock)
- D04-A Right front power window switch
- D04-B Right front power window switch
- D08 Passenger door speaker
- D10 Passenger tweeter speaker
- D14 Right front safety window module
- D16 Passenger door lamp
- D18 Right outside mirror & Mirror folding motor
- D26 Right front door lock actuator(RHD, With Dead lock)
- D-2 Joint connector
- FD02 Connection with FLOOR harness

( ) : PASSENGER

# DOOR HARNESS

## DOOR HARNESS (2)

HL-14

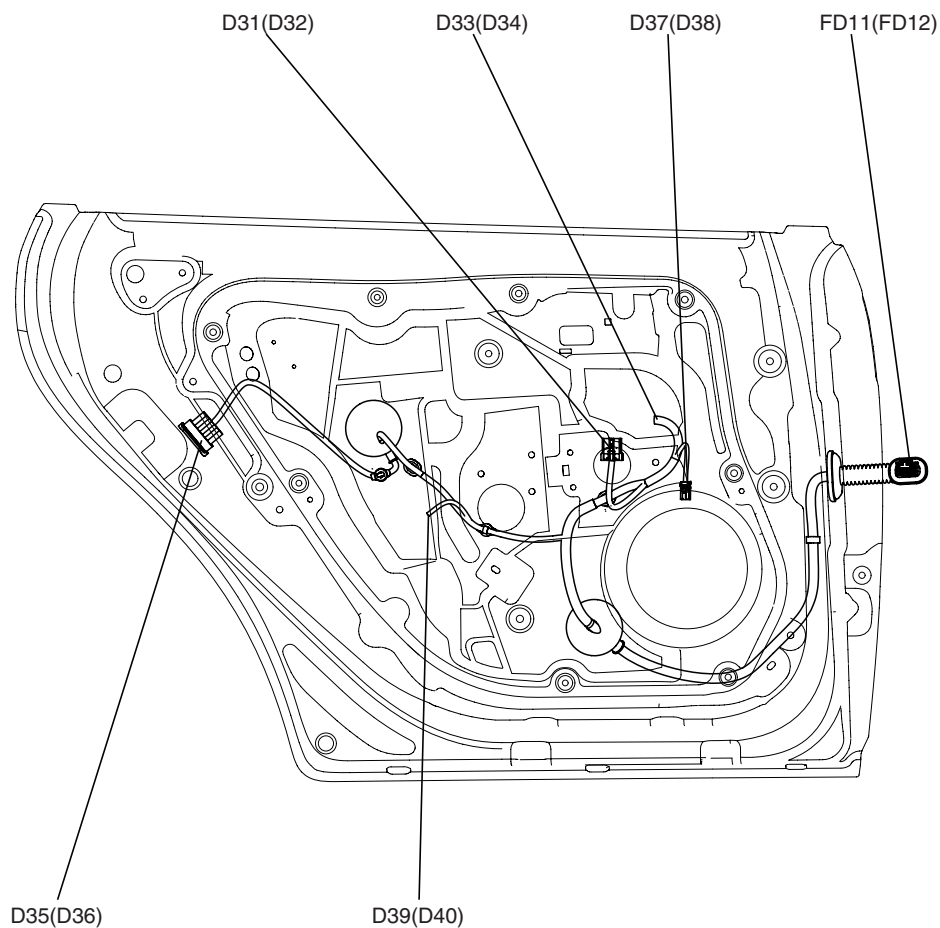

### LEFT REAR DOOR HARNESS

- D31 Left rear power window switch
- D33 Left rear power window motor
- D35 Left rear door lock actuator(W/O Dead lock)
- D35R Left rear door lock actuator(With Dead lock)
- D37 Left rear door speaker
- D39 Left rear door lamp
- FD11 Connection with FLOOR harness

### RIGHT REAR DOOR HARNESS

- D32 Right rear power window switch
- D34 Right rear power window motor
- D36 Right rear door lock actuator(W/O Dead lock)
- D36R Right rear door lock actuator(With Dead lock)
- D38 Right rear door speaker
- D40 Right rear door lamp
- FD12 Connection with FLOOR harness

( ) : RIGHT

REAR HARNESS (1)

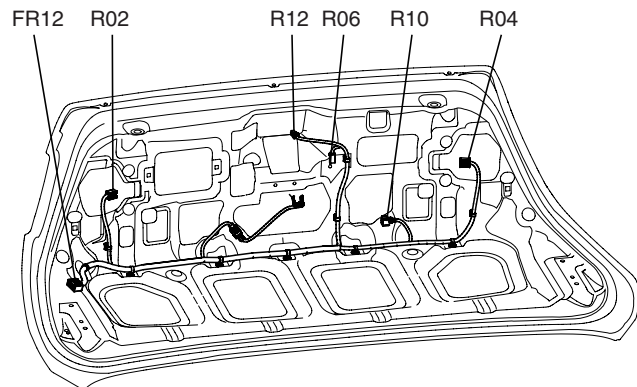

TRUNK LID HARNESS

- R02 Left rear combination lamp(IN)
- R04 Right rear combination lamp(IN)
- R06 Trunk lid outside handle switch
- R10 License lamp
- R12 Trunk lid motor
- FR12 Connection with FLOOR harness

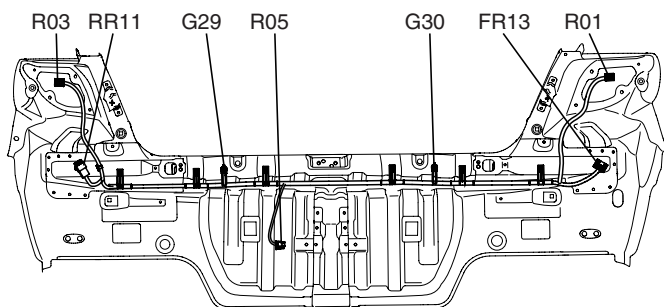

TRUNK ROOM HARNESS

- R01 Left rear combination lamp(OUT)
- R03 Right rear combination lamp(OUT)
- FR13 Connection with FLOOR harness
- G29 Ground
- G30 Ground

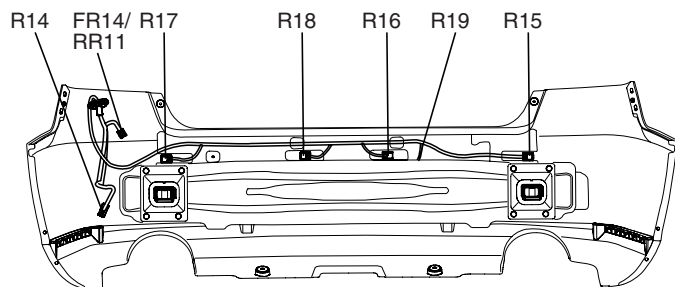

BACK WARNING EXT. HARNESS

- R15 Left side back warning sensor
- R16 Left back warning sensor
- R17 Right side back warning sensor
- R18 Right back warning sensor
- FR14 Connection with FLOOR harness

ROOF HARNESS (1)

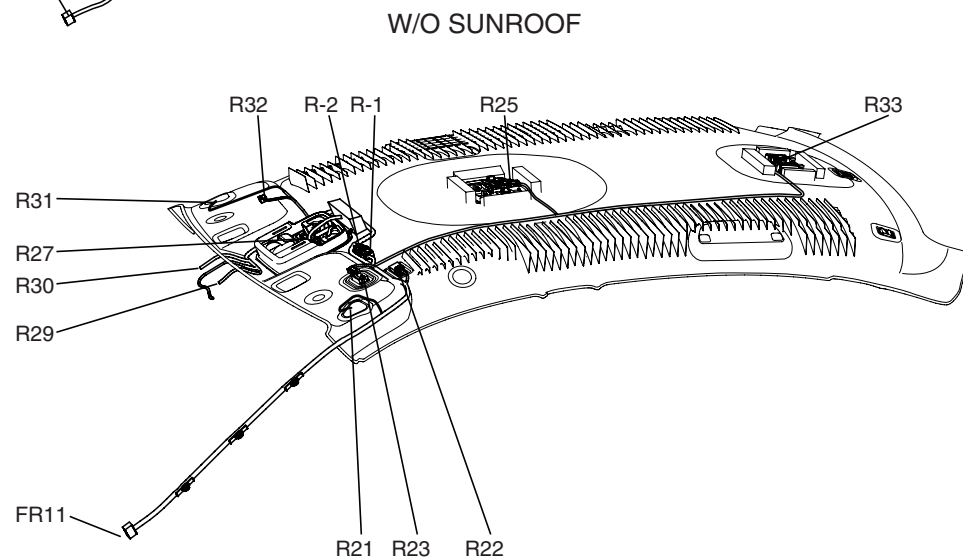
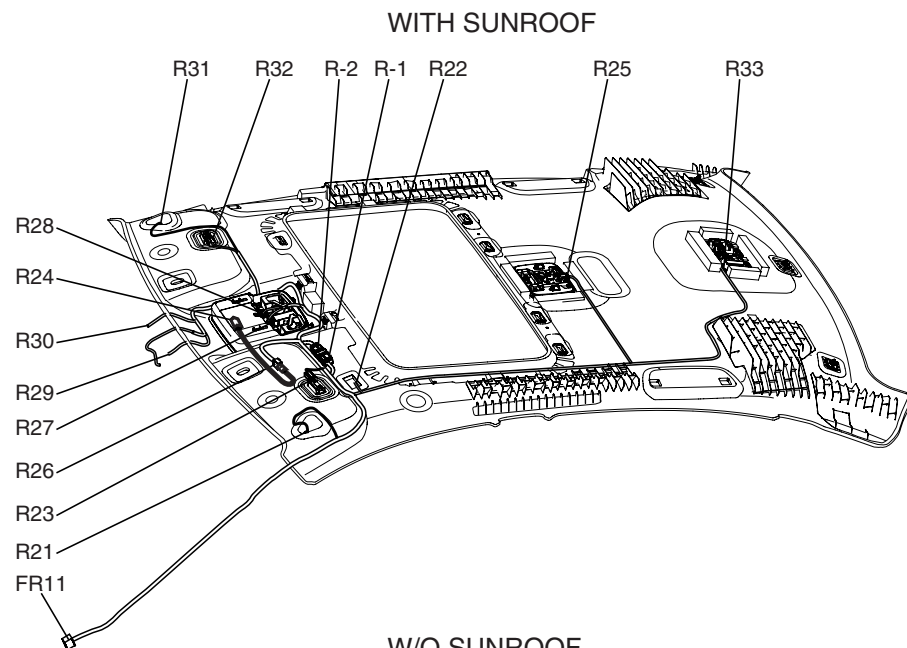

- R21 Left vanity lamp switch
- R23 Left vanity lamp
- R24 Sunroof motor
- R25 Room lamp
- R26 Overhead console lamp(Sunroof motor)
- R27 Map lamp
- R28 Sunroof switch
- R29 Electro chrome mirror
- R30 Rain sensor
- R31 Right vanity lamp switch
- R32 Right vanity lamp
- R33 Rear personal lamp
- R-1 Joint connector
- R-2 Joint connector
- FR11 Connection with FLOOR harness

AIR BAG HARNESS (1)

HL-17

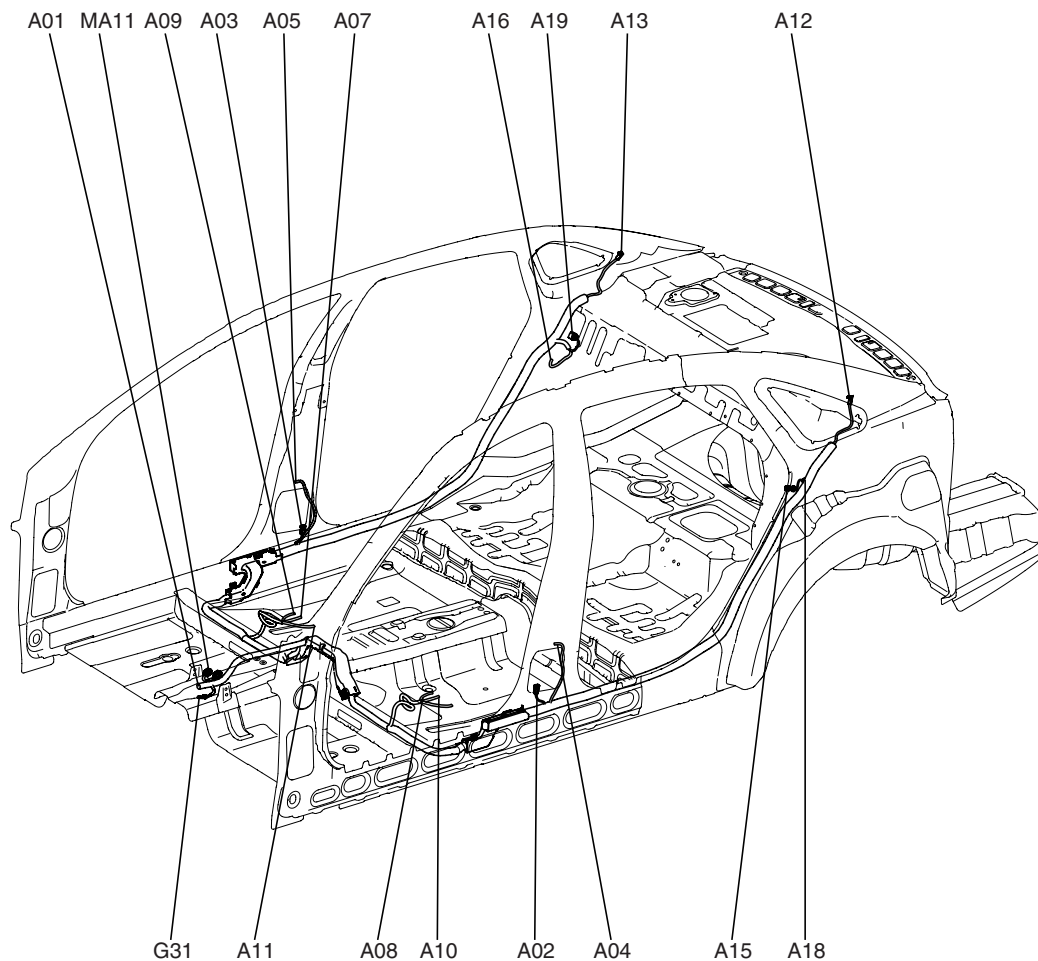

- A01 SRS control module
- A02 Driver seat belt pretensioner
- A03 Passenger seat belt pretensioner
- A04 Left front side impact sensor
- A05 Right front side impact sensor
- A07 Seat belt reminder mat
- A08 Left front side air bag
- A09 Right front side air bag
- A10 Driver seat buckle switch
- A11 Passenger seat buckle switch
- A12 Driver curtain air bag
- A13 Passenger curtain air bag
- A15 Left rear side air bag
- A16 Right rear side air bag
- A18 Left rear side impact sensor
- A19 Right rear side impact sensor
- MA11 Connection with MAIN harness
- G31 Ground

SEAT HARNESS (1)

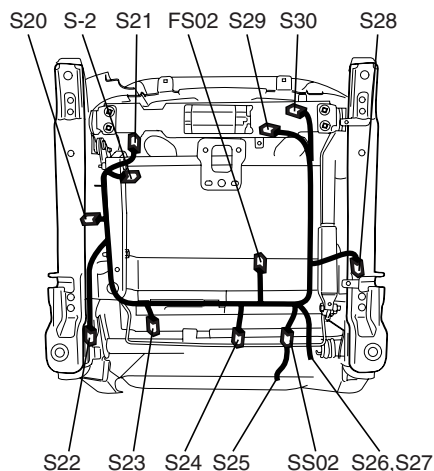
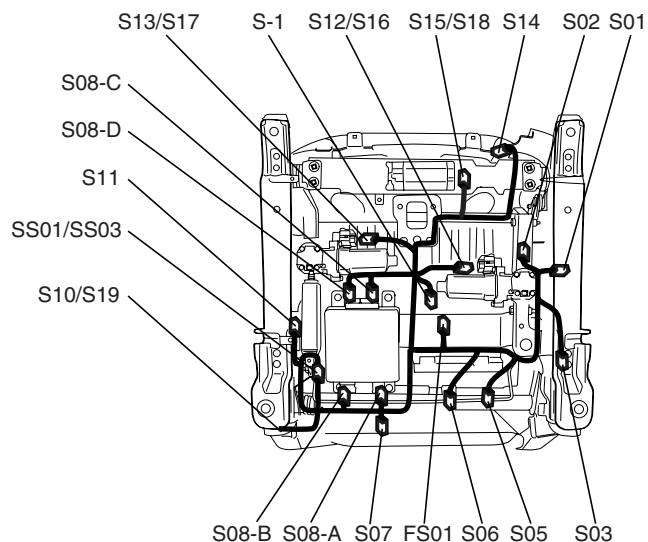

DRIVER POWER SEAT HARNESS

- S01 Driver seat manual switch(LHD)
- S01R Driver seat manual switch(RHD)
- S02 Front lumbar support switch(LHD)
- S02R Front lumbar support switch(RHD)
- S03 Driver reclining limit switch(LHD)
- S03R Driver reclining limit switch(RHD)
- S05 Front lumbar support motor
- S06 Driver reclining warmer
- S07 Driver cushion warmer
- S08-A,B,C,D IMS control module
- S10 Driver reclining motor(With IMS)
- S11 Driver slide limit switch(LHD)
- S11R Driver slide limit switch(RHD)
- S12 Front height adjuster motor(With IMS)
- S13 Rear height adjuster motor(LHD, With IMS)
- S13R Rear height adjuster motor(RHD, With IMS)
- S14 Driver seat warmer module
- S15 Driver slide motor(With IMS)
- S16 Front height adjuster motor(W/O IMS)
- S17 Rear height adjuster motor(W/O IMS)
- S18 Driver slide motor(W/O IMS)
- S19 Driver reclining motor(W/O IMS)
- S-1 Joint connector(With IMS)
- FS01 Connection with FLOOR harness
- SS01 Connection with DRIVER RECLINING MOTOR EXT. harness(With IMS)
- SS03 Connection with DRIVER RECLINING MOTOR EXT. harness(W/O IMS)

PASSENGER POWER SEAT HARNESS

- S20 Passenger seat manual switch(LHD)
- S20R Passenger seat manual switch(RHD)
- S22 Passenger reclining limit switch(LHD)
- S22R Passenger reclining limit switch(RHD)
- S23 Passenger cushion warmer
- S24 Passenger reclining warmer
- S25 Passenger reclining motor
- S28 Passenger slide limit switch(LHD)
- S28R Passenger slide limit switch(RHD)
- S29 Passenger seat warmer module
- S30 Passenger slide motor
- FS02 Connection with FLOOR harness
- SS02 Connection with PASSENGER RECLINING MOTOR EXT. harness