

INTRODUCTION

INTRODUCTION (2)

GI-2

STARTING SYSTEM

STARTING SYSTEM (2)

SD360-2

② Connector configurations (components)

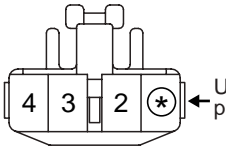
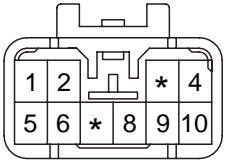
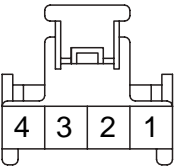
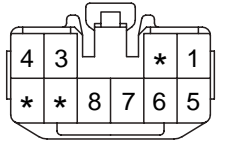
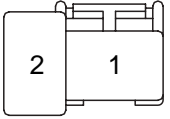
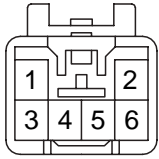
<p>M05</p>  <p>KET_090II_04F_W</p>	<p>M06</p>  <p>KET_090II_10M_W</p>	<p>M11</p>  <p>KUM_AR_04F_W</p>	<p>M13</p>  <p>KET_090II_10F_W</p>
<p>M67</p>  <p>AMP_PLM2_02F_B</p>	<p>M81</p>  <p>KET_090II_06M_W</p>	<p>BLANK</p>	<p>BLANK</p>

E2RG360B

Explanation of connector code

M05

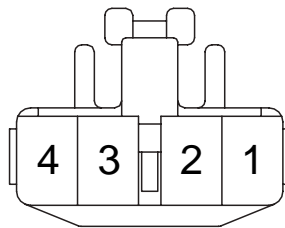

KET_090II_04F_W

a b c d e

a : Connector manufacturer

b : Terminal series number

c : The number of connector terminals

d : Connector distinguishing

- Female Pin : F
- Male Pin : M

e : Connector color abbreviations

- B (Black)
- Br (Brown)
- G (Green)
- Gr (Gray)
- L (Blue)
- R (Red)
- W (White)
- Y (Yellow)

① Pages by system/ Name of Schematic diagram

- Each page is consisted of circuits by system. This schematic diagram includes the path of electricity flow, connection condition for each switch, and the function of other relevant circuits at once. It is applicable to real service work.
- It is very important to understand relevant circuits exactly before troubleshooting diagnosis.
- Circuits by system depends upon part number and are indicated on schematic diagram index.

② Connector configuration (components)

- The connector figure of components in the schematic diagram by system is indicated on the last page of schematic diagram.
- It shows the front of the connector on the harness side when not to the harness connector. The terminal number on each connector can be obtained by following the pattern used in ⑤ connector view and numbering order. Unused terminals are marked with an asterisk (*).

③ Connector configurations (connection between harnesses)

- When connecting the harness with connector between harnesses, it shows female and male connectors and indicates them on the connector configurations group.

EM02

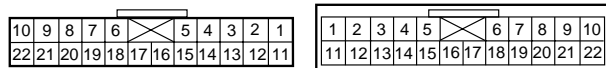

④ Component locations

- To find the components easily, a component locations diagram is indicated with "PHOTO NO" on the lower portion of the component name.
- To make it easy to distinguish connectors, the connector in the picture is indicated being installed in the vehicle.

PHOTO 03

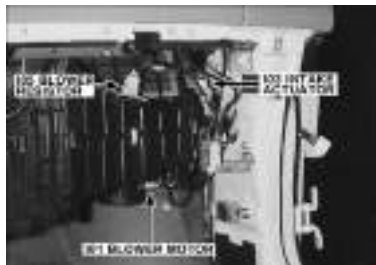

⑤ CONNECTOR VIEW AND NUMBERING ORDER

Female	Male	Remarks
		<p>It is not the shape of the connector housing, but the connector pin that distinguishes between male or female connectors. When numbering female and male connectors, refer to the numbering order in the following table. Some connectors may not follow this method of numbering order. For individual detailed numbering, refer to the CONNECTOR CONFIGURATIONS.</p>
		<p>Numbered in order from upper right to lower left</p> <p>Numbered in order from upper left to lower right</p>

NOTE

UNLESS OTHERWISE STATED, ALL CONNECTOR VIEWS ARE FROM THE TERMINAL SIDE OF THE CONNECTOR.

INTRODUCTION

INTRODUCTION (4)

GI-4

⑥ WIRE COLOR ABBREVIATIONS

The following abbreviations are used to identify wire colors in the circuit schematics.

Symbol	Color of wire	Symbol	Color of wire
B	Black	O	Orange
Br	Brown	P	Pink
G	Green	R	Red
Gr	Gray	W	White
L	Blue	Y	Yellow
Lg	Light Green	Pp	Purple
T	Tan	LI	Light Blue

* **(Y/B)**: Black stripe with yellow ground (2 colors)

↑ ↑
the color of the color of
background stripe

⑦ HARNESS CLASSIFICATION

Electrical wiring connectors are classified according to the wiring parts in the Harness Layouts.

Symbol	Harness name	Location
E	Engine, Battery harness	Engine, Front end module, Battery
M	Main, Steering Remocon, Console EXT. harness	Passenger compartment
F	Floor, BWS EXT. harness	Floor
C	Control, Injector, Ignition Coil, MTM EXT. harness	Engine compartment, Passenger compartment
R	Roof, Tail Gate, Rear HTD. harness	Roof, Tail Gate
A	Air bag harness	Under crash pad and Floor
D	Door harness	Door

* It depends on vehicles, it is necessary to check the harness name symbol on the harness layouts for detailed symbol.

⑧ CONNECTOR IDENTIFICATION

A connector identification symbol consists of a wiring harness location classification symbol corresponding to a wiring harness location and number corresponding to the connector. These connector locations can be found in the HARNESS LAYOUTS.

For example:

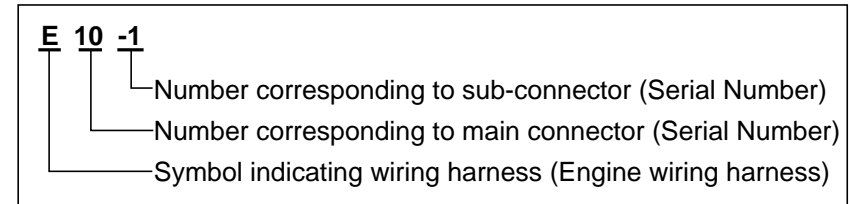

NOTE

Connectors which connect each wiring harness are represented by the following symbols.

For example:

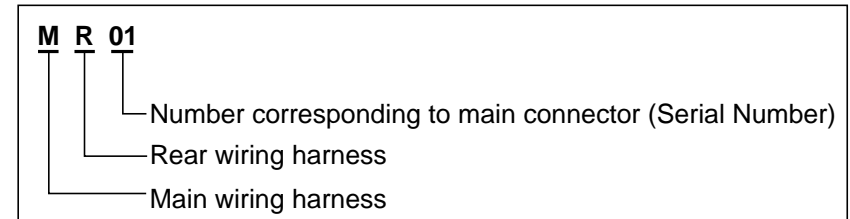

JUNCTION BLOCK IDENTIFICATION

A junction block identification symbol consists of a wiring harness location classification symbol corresponding to a wiring harness location and number corresponding to the connector in the junction block.

For example:

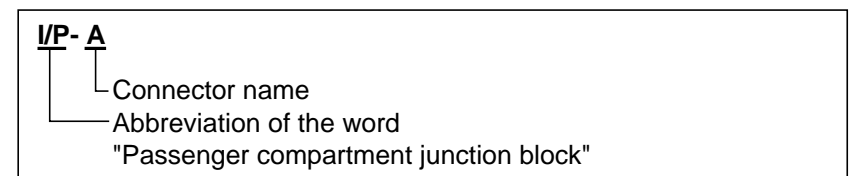

HARNESS LAYOUTS

Harness layouts show the routing of the major wiring harnesses, the in-line connectors and the splices between the major harnesses. These layouts will make electrical troubleshooting easier.

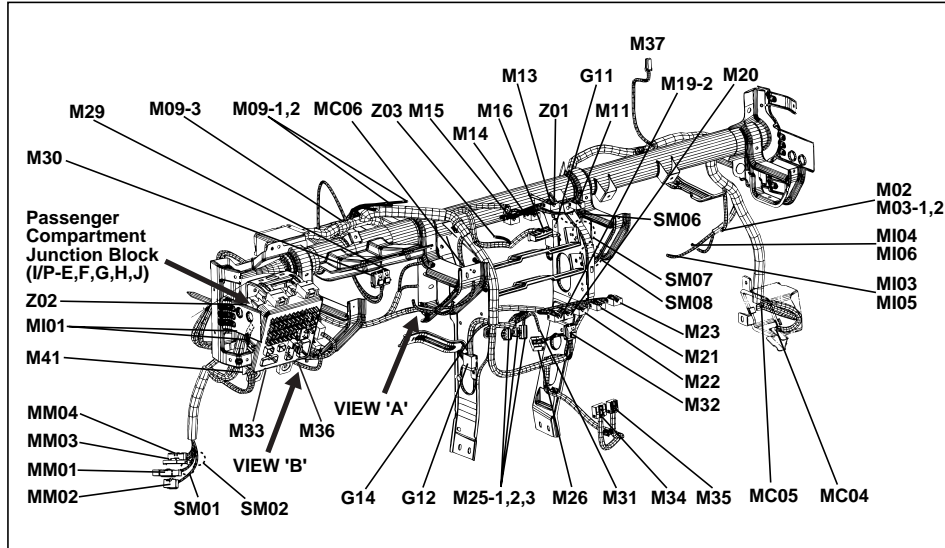









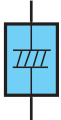

SYMBOLS (1)

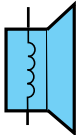
Section	Symbol	Meaning	Section	Symbol	Meaning	Section	Symbol	Meaning	Section	Symbol	Meaning
C O M P O N E N T		A solid line means the entire component is shown.	C O N N E C T O R		Shows the name of each connector on the component location index for reference.	S H I E L D W I R E		This represents RFI (Radio Frequency Interference) Shielding around a wire. The shielding is always connected to ground.	L A M P		Double filament
		A broken line indicates only part of the component is shown.			Indicates the number of corresponding terminal. (Only relevant terminal on the corresponding schematic diagram).			Single filament			
		This means the connector connects directly to the component.	W I R E		A wavy line means the wire is broken but is to be continued.	J O I N T C O N N E C T O R		This is a connector showing the joining wires.	D I O D E		Diode
		This indicates the connector connects to a lead (pigtail), wired directly to the component.			Wire insulation is yellow with a red strip.			Led diode			
		This indicates a screw terminal on the component.	S P L I C E S		Current path is continued on the same page or another page. The arrow shows the direction of current flow. You should look for the "A" in the marked position.	S L O W B L O W		Power supplied at all times. Name Capacity	T R		NPN
		This ground symbol (dot and 3 lines overlapping the component) means the housing of the component is attached to a metal part of the vehicle.			A wire connects to another circuit. The wire is shown again on that circuit which the arrow is pointing.			PNP			
		The name of the component appears next to its upper right corner.	G R O U N D		Name of Circuit	F U S E		This means power is supplied with the ignition on position. This means the short bar connects to other fuses. Identification Current rating	G E N E R A L C O M P O N E N T S Y M B O L		These switches move together: a dashed line shows a mechanical connection between them.
		Shows the number of pictures for component location.			Splices are numbered and shown as a dot with circle. The exact location and connection of these splices may vary among vehicles.			Control battery power at all times			Heater

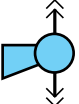
SYMBOLS

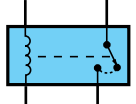
SYMBOLS (2)

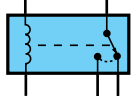
GI-7

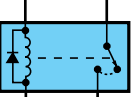
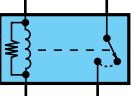
Section	Symbol	Meaning	Section	Symbol	Meaning
GENERAL COMPONENTS SYMBOL		Sensor	GENERAL COMPONENTS SYMBOL		Condenser
		Sender			Speaker
		Injector			Horn, Buzzer, Siren, Chime Bell
		Solenoid	RELAY		Normally open contact
		Motor			This is a relay shown with no current flowing through its coil. When a current flows through coil, contact will toggle.
		Battery			Diode interior relay
				Resistance interior relay	

TROUBLESHOOTING INSTRUCTIONS (1)

GI-8

TROUBLESHOOTING INSTRUCTIONS

TROUBLESHOOTING PROCEDURES

The following five-step troubleshooting procedure is recommended.

1. Verify the customer's complaints

Turn on all the components in the problem circuit to check the accuracy of the customer's complaints. Note the symptoms. Do not begin disassembly or testing until you have narrowed down the probable causes.

2. Read and analyze the schematic diagram

Locate the schematic for the problem circuit. Determine how the circuit is supposed to work by tracing the current paths from the power source through the system components to ground. If you do not understand how the circuit should work, read the circuit operation text. Also check other circuits that share with the problem circuit. The name of circuits that share the same fuse, ground, or switch, for example, are referred to on each diagram. Try to operate any shared circuits you did not check in step 1. If the shared circuit works, the shared wiring is okay, and the cause must be within the wiring used only by the problem circuit.

If several circuits fail at the same time, the fuse or ground is a likely cause.

3. Inspect the circuit/ component with the problem isolated

Make a circuit test to check the diagnosis you made in step 2. Remember that a logical, simple procedure is the key to efficient troubleshooting. Narrow down the probable causes using the troubleshooting hints and system diagnosis charts. Test for the most likely cause of failure first. Try to make tests at points that are easily accessible.

4. Repair the problem

Once the problem is found, make the necessary repairs.

5. Make sure the circuit works

Repeat the system check to be sure you have repaired the problem. If the problem was a blown fuse, be sure to test all of the circuits on that fuse.

TROUBLESHOOTING EQUIPMENT

VOLTMETER AND TEST LAMP

Use a test lamp or a voltmeter on circuits without solidstate units and use a test lamp to check for voltage. A test lamp is made up of a 12-volt light bulb with a pair of leads attached. After grounding one lead, touch the other lead to various points along the circuit where voltage should be present. When the bulb goes on, there is voltage at the point being tested.

CAUTION

A number of circuits include solid-state modules, such as the Engine Control Module(ECM), used with computer command control injection. Voltage in these circuits should be tested only with a 10-megaohm or higher impedance digital multimeter. Never use a test lamp on circuits that contain solid state modules. Damage to the modules may result.

A voltmeter can be used in place of a test lamp. While a test lamp shows whether the voltage is present or not, a voltmeter indicates how much voltage is present.

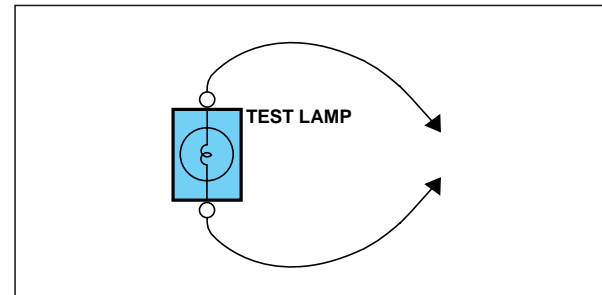
**SELF-POWERED TEST LAMP AND OHMMETER**

Use a self-powered test lamp or an ohmmeter to check for continuity. The ohmmeter shows how much resistance there is between two points along a circuit. Low resistance means good continuity.

TROUBLESHOOTING INSTRUCTIONS

TROUBLESHOOTING INSTRUCTIONS (2)

GI-9

CAUTION

Never use a self-powered test lamp on circuits that contain solid state modules. Damage to these modules may result.

An ohmmeter can be used in place of a self-powered test lamp. The ohmmeter shows how much resistance there is between two points along a circuit. Low resistance means good continuity.

Circuits which include any solid-state devices should be tested only with a 10-megaohm or higher impedance digital multimeter. When measuring resistance with a digital multimeter, the battery negative terminal should be disconnected. Otherwise, there may be incorrect readings. Diodes and solid-state devices in a circuit can make an ohmmeter give a false reading. To find out if a component is affecting a measurement, take one reading, reverse the leads and take a second reading. If different the solid-state device is affecting the measurement.

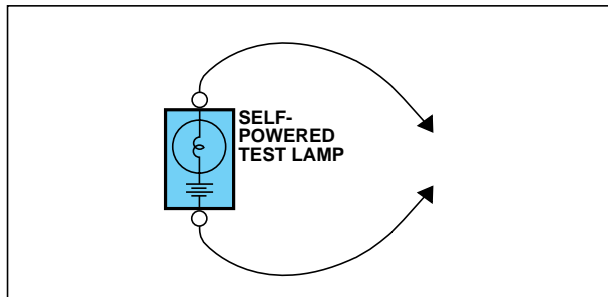

JUMPER WIRE WITH FUSE

Use a jumper wire with a fuse to by-pass an open circuit.

A jumper wire is made up of an in-line fuse holder connected to a set of test leads. This tool is available with small clamp connectors providing adaption to most connectors without damage.

CAUTION

Do not use a fuse with a higher rating than the specified fuse that protects the circuit being tested. Do not use this tool in any situation to substitute an input or output at the solid-state control module, such as ECM, TCM, etc.

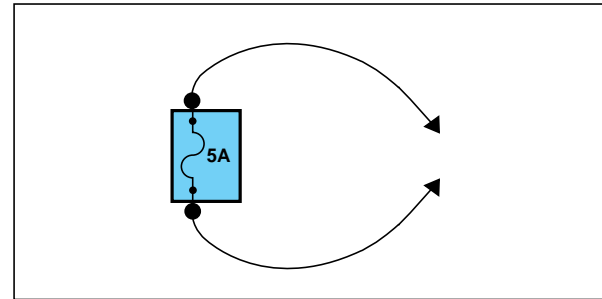

SHORT FINDER

A short finder is available to locate a short to ground. The short finder creates a pulsing magnetic field in the shorted circuit and shows you the location of the short through body trim or sheet metal.

TROUBLESHOOTING TEST

1. TESTING FOR VOLTAGE

This test measures voltage in a circuit. When testing for voltage at a connector, you do not have to separate the two halves of the connector. Instead, probe the connector from the back(backprobe). Always check both sides of the connector because dirt and corrosion between its contact surfaces can cause electrical problems.

- A. Connect one lead of a test lamp or voltmeter to a ground. If you are using a voltmeter, be sure it is the voltmeter's negative test lead you have connected to ground.
- B. Connect the other lead of the test lamp or voltmeter to a selected test point(connector or terminal).
- C. If the test lamp glows, there is voltage present. If you are using a voltmeter, note the voltage reading. A loss of more than 1 volt from specification indicates a problem.

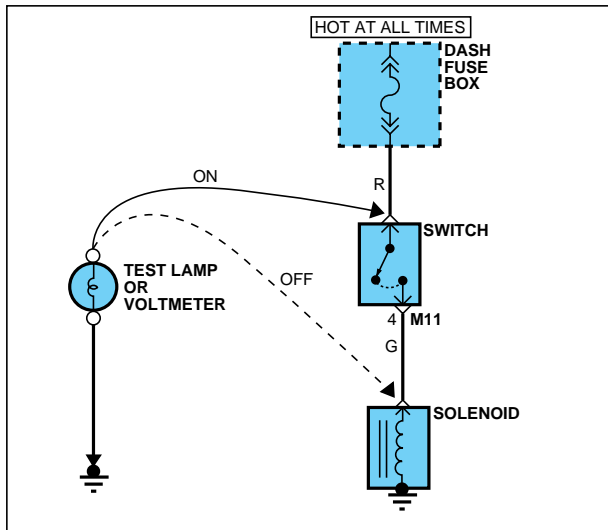

2. TESTING FOR CONTINUITY

- A. Disconnect the battery negative terminal.
- B. Connect one lead of a self-powered test lamp or ohmmeter to one end of the part of the circuit you wish to test. If you are using an ohmmeter, hold the leads together and adjust the ohmmeter to read zero ohms.
- C. Connect the other lead to the other end.
- D. If the self-power test lamp glows, there is continuity. If you are using an ohmmeter, low or zero resistance means good continuity.

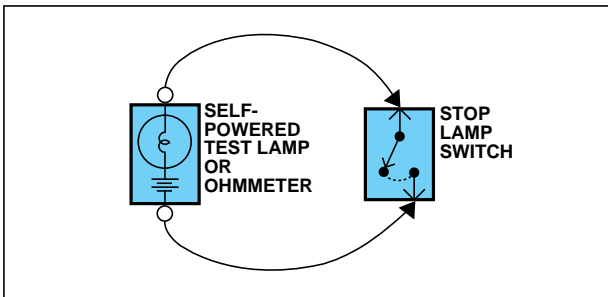

3. TESTING FOR SHORT TO GROUND

- A. Disconnect the battery negative terminal.
- B. Connect one lead of a self-powered test lamp or an ohmmeter to the fuse terminal on the load side.
- C. Connect the other lead to a ground.
- D. Beginning near the fuse block move the harness from side to side. Continue this procedure (about six inches apart) while watching the self-powered test lamp or ohmmeter.
- E. When the self-powered test lamp glows, or ohmmeter registers, there is a short to a ground in the wiring near that point.

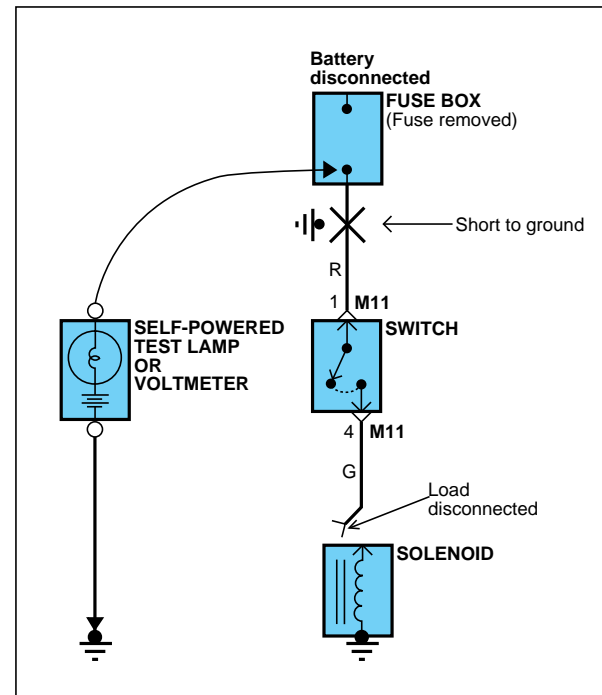

4. TESTING FOR A SHORT WITH A SHORT FINDER

- A. Remove the blown fuse. Leave the battery connected.
- B. Connect the short finder across the fuse terminals.
- C. Close all switches in series in the circuit that is being testing.
- D. Turn on the short circuit locator. It sends pulses of current to the short.
This creates a pulsing magnetic field around the wiring between the fuse box and the short.
- E. Beginning at the fuse box, slowly move the short finder along the circuit wiring. The meter will show current pulses through sheet metal and body trim. As long as the meter is between the fuse and the short, the needle will move with each current pulse. Once the meter is moved past the point of the short, the needle will stop moving. Check around this area to locate the cause of the short circuit.

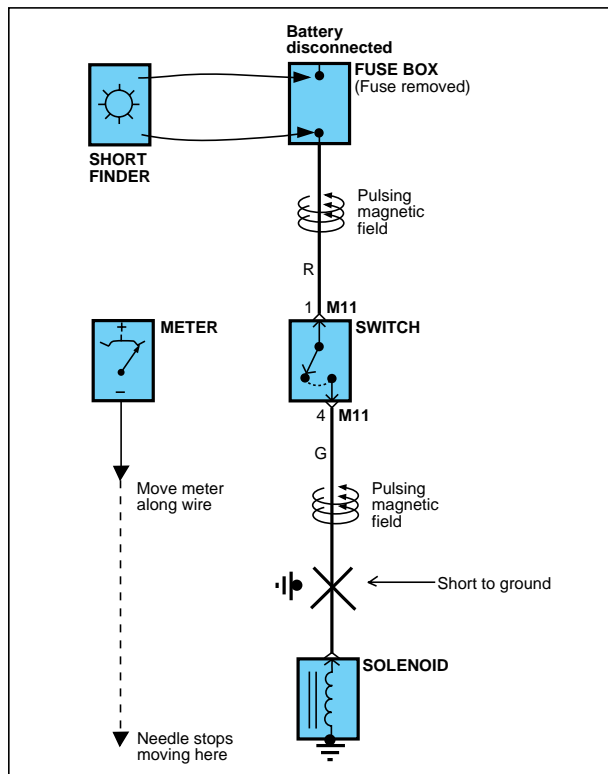

WIRING REPAIR (1)

*** REFERENCE SERVICE TOOLS**

Tool Number	Tool Name
TRK00A	Wiring Repair Kit (Standard Kit)
TRK001	Wire Stripper Set
TRK002	Remover Tool Set
TRK003	Terminal Tension Gauge Set
TRK004	Cable Tie Set
TRK005	Shrink Tube Set
TRK006	Jump Connector Kit(A)
TRK007~10	General Connector Kit(B~E)
TRK011	Terminal With Lead Wire Kit(F)
TRK012	Composition Kit(G)
TRK013	Lead Wire Set
TRK014	Carrying Case
TRK015	User's Guide & Parts Information
TRK016	Inner Box(Large)
TRK017	Inner Box(Small)
TRK018	Solder

* For more details, refer to the User's guide & parts Information of the Wiring Repair Kit (Pub. No. : OSG200208).

*** Wiring Repair Kit**

[Standard Kit (TRK00A)]

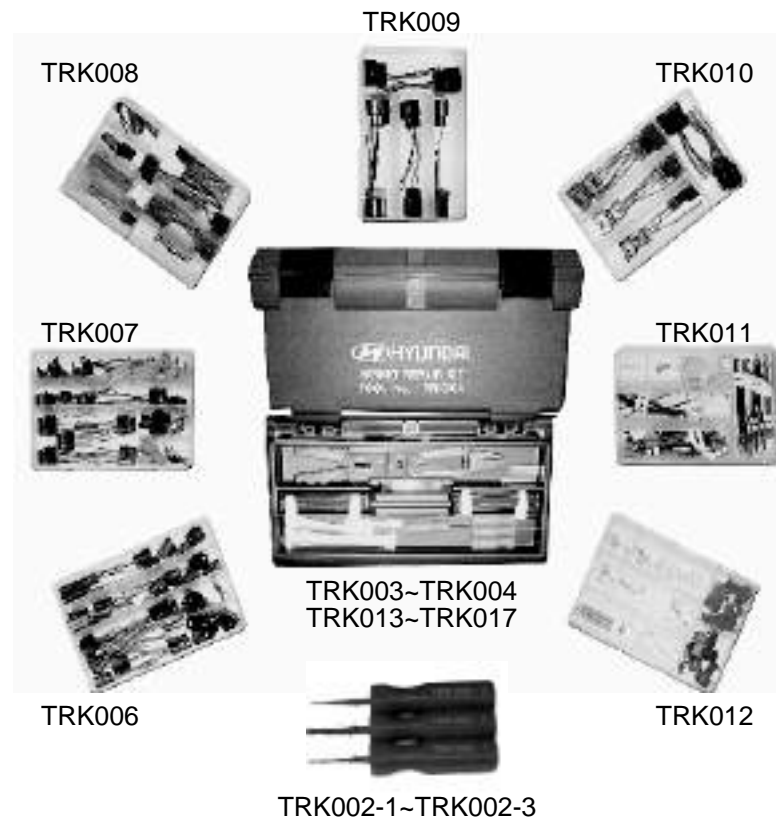

*** Optional Items**



REWORK PROCEDURE

1. Use of Wire stripper set (TRK001)

- 1) Disconnect the battery cable.
- 2) Choose the correct clamping slot for the wire and strip off the wire coat.

⦿ If the incorrect crimping slot is used, the terminal may be damaged and may not fit into the connector.



2. Use of Remover tool set (TRK002)

▶ **Flat tip type** : Removal of single locking male/female terminal from the connector.

- 1) Remove the front or rear retainer (holder, stopper) of the connector.



- 2) Ensure that the tip of the tool is inserted into the gap between the elastic arm of key and terminal.



- 3) Remove the terminal and check the terminal condition, if there is a damaged, replace it with a new terminal.

▶ **Double tip type** : Removal of double locking male/female terminal from the connector.



3. Use of Terminal tension gauge set (TRK003)

- 1) Select the tension gauge that matches the female terminal to be checked.



- 2) Insert a tension gauge into the female terminal and check the terminal condition. (as shown in the photograph)



⦿ If the tension of female terminal is not tight enough, remove it and replace the terminal and wire assembly (including seal).



4. Use of Ring terminal (TRK012-4)

1) Strip off about 5mm of the wire coat at the end of the wire.



2) Joint the stripped wire with ring terminal and crimp using wire stripper.



3) Put the shrink tube over the connection area and shrink the tube using electrical hot gun.



5. Use of Inline solder (TRK012-5) and Shrink tube set (TRK005)

1) Strip off about 5mm of the wire coat at the end of the wires.



2) Insert each wire into the opposite ends of the inline solder and crimp using wire stripper.



3) Put the shrink tube over the connection area and shrink the tube using electrical hot gun.



◎ Shrink tube should be securely wrapped around the inline solder area.



6. Use of Terminal with lead wire kit (TRK011)

- 1) Remove the damaged connector and terminal using remover tool.



- 2) Select the right wire, which is fitted with the terminal specification from terminal with lead wire box and cut of the end of wire using wire stripper.



- 3) Put the end of each cut off wire in the middle of the splice joint terminal and compress using wire stripper.



- 4) Put the shrink tube over the connection area and shrink the tube using electrical hot gun.



- 5) Insert the terminal with lead wire into the connector.



FUSE & RELAY INFORMATIONS (1)

SD100-1

I/P JUNCTION BOX

< LHD >

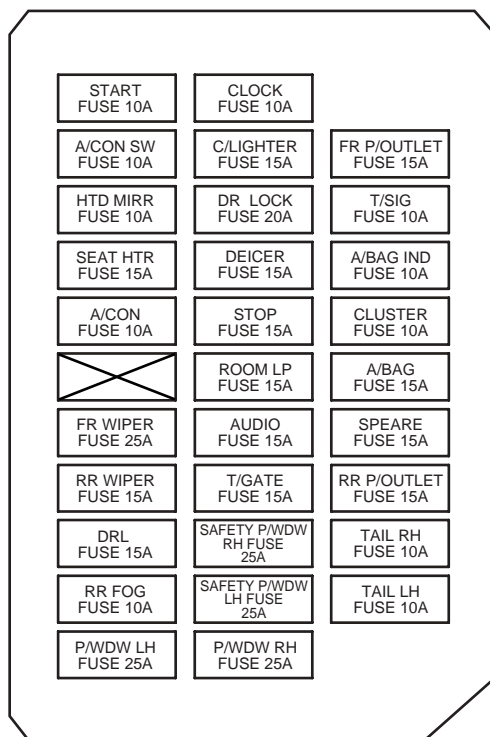

< RHD >

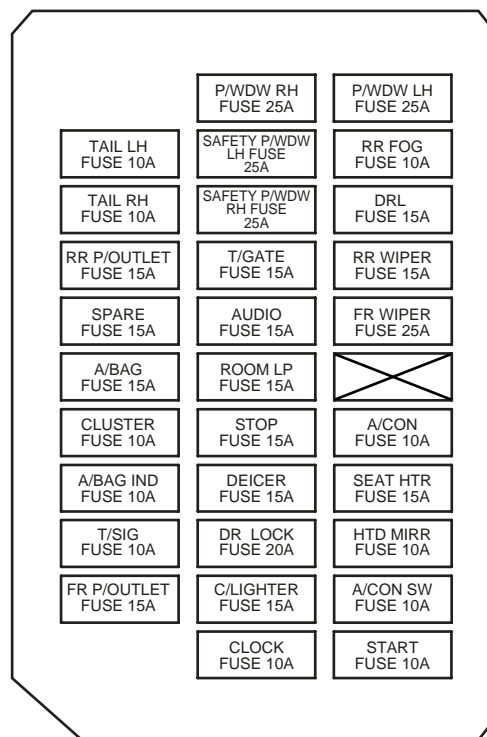

< REAR >

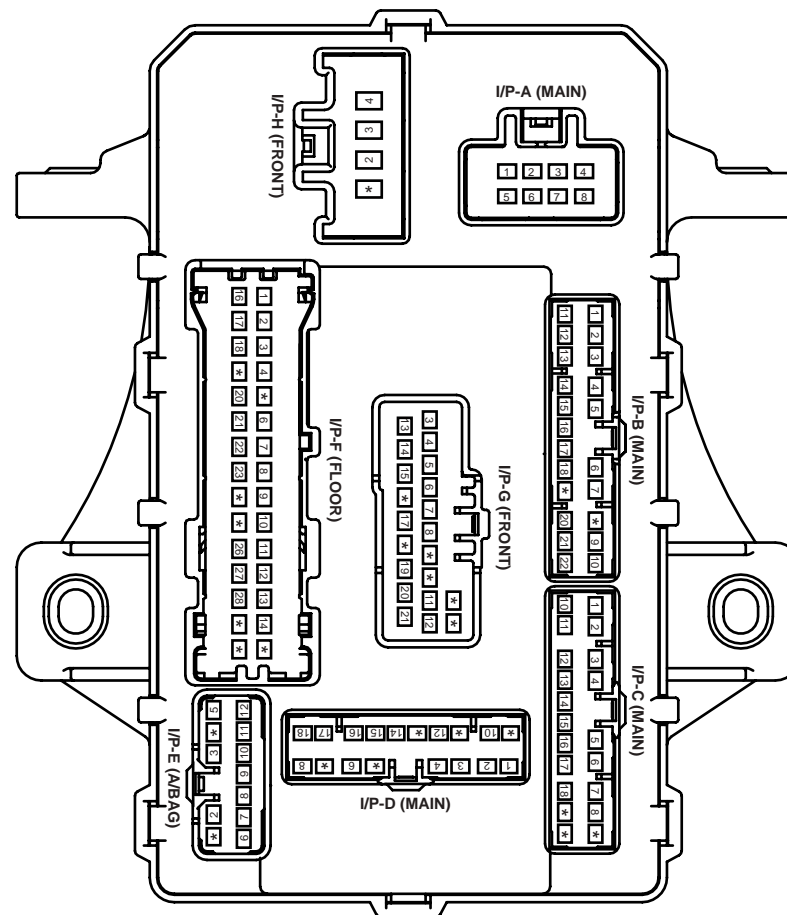

✘ USE THE DESIGNATED FUSE ONLY

FUSE & RELAY INFORMATIONS

FUSE & RELAY INFORMATIONS (2)

SD100-2

CIRCUIT

FUSE		(A)	Circuit Protected
START		10A	Ignition Lock Switch, ICM Relay Box (Burglar Alarm Relay), Start Relay
A/CON SW		10A	A/C Control Module
HTD MIRR		10A	A/C Control Module, ECM (G4FC), PCM (G4FC), Power Outside Mirror & Mirror Folding Motor, Passenger Air Bag SBR
SEAT HTR		15A	Front Seat Heater Switch LH/RH, Front Seat Heater Control Module LH/RH
A/CON		10A	A/C Control Module, BCM, Incar Temperature Sensor, Fusible Link Box (D4FB/D4EA), Rain Sensor, Blower Relay, Stop Lamp Failure Module, Sunroof Control Module, Electro Chromic Mirror, ICM Relay Box (Rain Sensor Relay)
FR WIPER		25A	Multifunction Switch, Front Wiper Relay ,Front Wiper Motor
RR WIPER		15A	Multifunction Switch, Rear Wiper Control Module, Rear Wiper Motor
DRL		15A	BCM
RR FOG		10A	ICM Relay Box (Rear Fog Lamp Relay)
P/WDW LH		25A	Power Window Main Switch, Rear Power Window Switch LH
CLOCK		10A	Audio, ATM Key Lock Control Module, Power Outside Mirror & Mirror Folding Switch, Digital Clock, Navigation Unit
C/LIGHTER		15A	Cigarette Lighter
DR LOCK		20A	Sunroof Control Module, ICM Relay Box (Door Unlock/Lock Relay, Dead Lock Relay)
DEICER		15A	ICM Relay Box (Front Deicer Relay)
STOP		15A	ATM Shift Lever Switch, Stop Lamp Switch, Key Solenoid, Stop Lamp Failure Module
POWER CONNECTOR	ROOM LP	15A	Luggage Lamp, Data Link Connector, Instrument Cluster, Room Lamp, Vanity Lamp Switch LH/RH, A/C Control Module, BCM, Ignition Key ILL. & Door Warning Switch, Sunroof Switch, Tire Pressure Monitoring Module, Map Lamp, Rear Parking Assist Buzzer, Power Outside Mirror & Mirror Folding Switch, Digital Clock
	AUDIO	15A	Audio, Navigation Unit
T/GATE		15A	Tail Gate Actuator, BCM, Tail Gate Relay
SAFETY P/WDW RH		25A	Rear Safety Power Window Module RH, AMP, Passenger Safety Power Window Module
SAFETY P/WDW LH		25A	Rear Safety Power Window Module LH, Driver Safety Power Window Module
P/WDW RH		25A	Power Window Main Switch, Rear Power Window Switch RH, Passenger Power Window Switch
FR P/OUTLET		15A	Front Power Outlet
T/SIG		10A	Hazard Switch
A/BAG IND		10A	Instrument Cluster, A/C Control Module, Passenger Air Bag SBR
CLUSTER		10A	Instrument Cluster, EPS Control Module, ESP Switch, BCM, ATM Key Lock Control Module, Pre-Excitation Resistor, Front Seat Heater Control Module LH/RH, Rear SBR Control Module, Tire Pressure Monitoring Module
A/BAG		15A	SRS Control Module, PAD Switch, A/C Control Module
RR P/OUTLET		15A	Rear Power Outlet, E/R Junction Box (Head Lamp Lo/Hi Relay)
TAIL RH		10A	Rear Combination Lamp RH, Glove Box Lamp, Head Lamp RH, Shunt Connector (W/O DRL), Front Fog Lamp Relay, License Lamp, Rheostat Relay (With DRL)
TAIL LH		10A	Head Lamp LH, License Lamp, Rear Combination Lamp LH

✘ USE THE DESIGNATED FUSE ONLY

FUSE & RELAY INFORMATIONS

FUSE & RELAY INFORMATIONS (3)

SD100-3

E/R JUNCTION BOX

< FRONT >

< REAR >

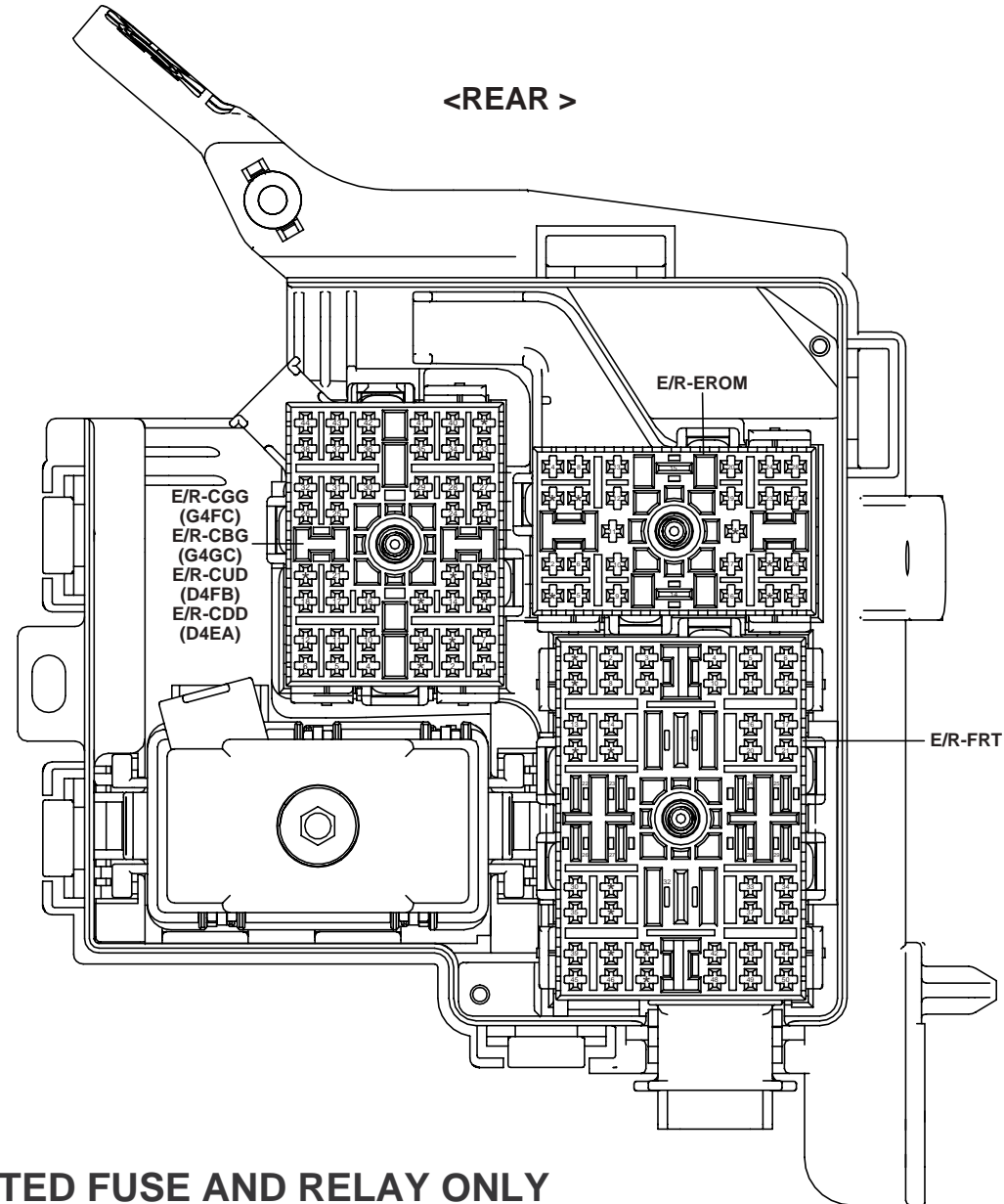
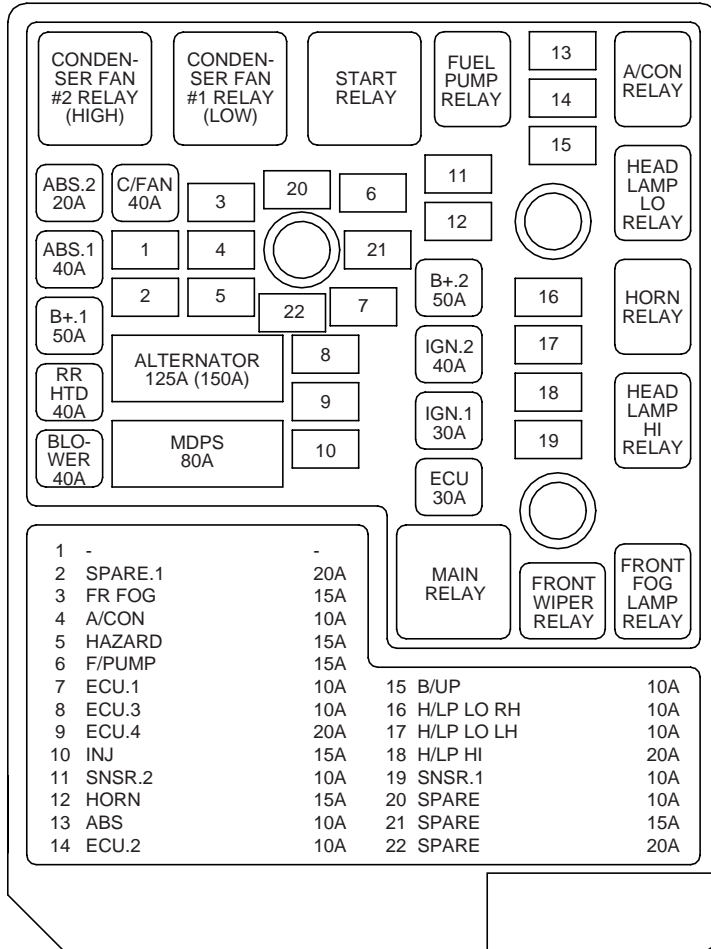

※ USE THE DESIGNATED FUSE AND RELAY ONLY

FUSE & RELAY INFORMATIONS

FUSE & RELAY INFORMATIONS (4)

SD100-4

CIRCUIT

Description		(A)	Circuit Protected
FUSIBLE LINK	ALTERNATOR	125A(GSL) 150A(DSL)	Generator, Fusible Link Box (D4FB/D4EA)
	MDPS	80A	EPS Control Module
	ABS.2	20A	ESP Control Module, ABS Control Module, Multipurpose Check Connector
	ABS.1	40A	ESP Control Module, ABS Control Module, Multipurpose Check Connector
	B+.1	50A	I/P Junction Box (Tail Lamp Relay, Power Window Relay, DRL Fuse, RR Fog Fuse, Safety P/WDW LH Fuse, Safety P/WDW RH Fuse)
	RR HTD	40A	I/P Junction Box (Rear Defogger Relay)
	BLOWER	40A	Blower Relay
	C/FAN	40A	Condenser Fan #1 Relay (Low), Condenser Fan #2 Relay (High)
	B+.2	50A	I/P Junction Box (Audio Fuse, Room LP Fuse, Deicer Fuse, T/GATE Fuse, Stop Fuse, DR Lock Fuse, RR P/OUTLET Fuse)
	IGN.2	40A	Ignition Switch, Start Relay
IGN.1	30A	Ignition Switch	
ECU	30A	Main Relay, PCM/ECM	
FUSE	FR FOG	15A	Front Fog Lamp Relay
	A/CON	10A	A/Con Relay
	HAZARD	15A	Hazard Switch, ICM Relay Box (Hazard Relay)
	F/PUMP	15A	Fuel Pump Relay
	ECU.1	10A	ECM (G4FC), PCM (G4FC), Generator (D4EA), TCM (D4FB)
	ECU.3	10A	ECM (D4FB/D4EA)
	ECU.4	20A	ECM (D4FB/D4EA)
	INJ	15A	A/Con Relay, Fuel Pump Relay, Injector #1, 2, 3, 4 (G4FC/G4GC), PCM (G4FC/G4GC), Oil Control Valve (G4FC/G4GC), ECM (G4FC/G4GC), Purge Control Solenoid Valve (G4GC), VGT Actuator (D4FB/D4EA), Fusible Link Box (D4FB/D4EA), Throttle Flap Actuator (D4FB), EGR Control Actuator (D4FB/D4EA), Immobilizer Module (D4FB), Air Heater Relay (D4FB), Electrical Throttle Actuator (D4FB/D4EA), Camshaft Position Sensor (D4FB/D4EA), Idle Speed Control Actuator (G4FC/G4GC)
	SNSR.2	10A	Pulse Generator 'A', 'B' (G4FC/G4GC/D4FB), Air Flow Sensor (D4FB/D4EA), TCM (D4FB), PCM (G4FC/G4GC), Stop Lamp Switch (G4FC/G4GC), Fuel Filter Warning Switch (D4FB/D4EA), ECM (D4FB/D4EA), Vehicle Speed Sensor
	HORN	15A	Horn Relay, ICM Relay Box (Burglar Alarm Horn Relay)
	ABS	10A	ESP Control Module, ABS Control Module, Yaw Rate Sensor, Mutipupose Check Connector
	ECU.2	10A	Condenser (G4FC), Ignition Coil #1, 2, 3, 4 (G4FC), PCM (G4GC)
	B/UP	10A	Back-up Lamp Switch, Multifunction Switch, Cruise Control Module, Transaxle Range Switch
	H/LP LO RH	10A	Head Lamp RH, Head Lamp Leveling Actuator RH
	H/LP LO LH	10A	Head Lamp LH, Head Lamp Leveling Actuator LH, Head Lamp Leveling Switch, Instrument Cluster
	H/LP HI	20A	Head Lamp Hi Relay
SNSR.1	10A	Immobilizer Module (G4FC/G4GC), Oxygen Sensor (G4FC/G4GC), PCM (G4FC), Camshaft Position Sensor (G4FC/G4GC), Purge Control Solenoid Valve (G4FC), Crankshaft Position Sensor (G4GC), Stop Lamp Switch (D4FB/D4EA), Lambda Sensor (D4FB/D4EA), Immobilizer Module (D4EA)	

※ USE THE DESIGNATED FUSE AND RELAY ONLY

FUSIBLE LINK BOX

D4FB/D4EA

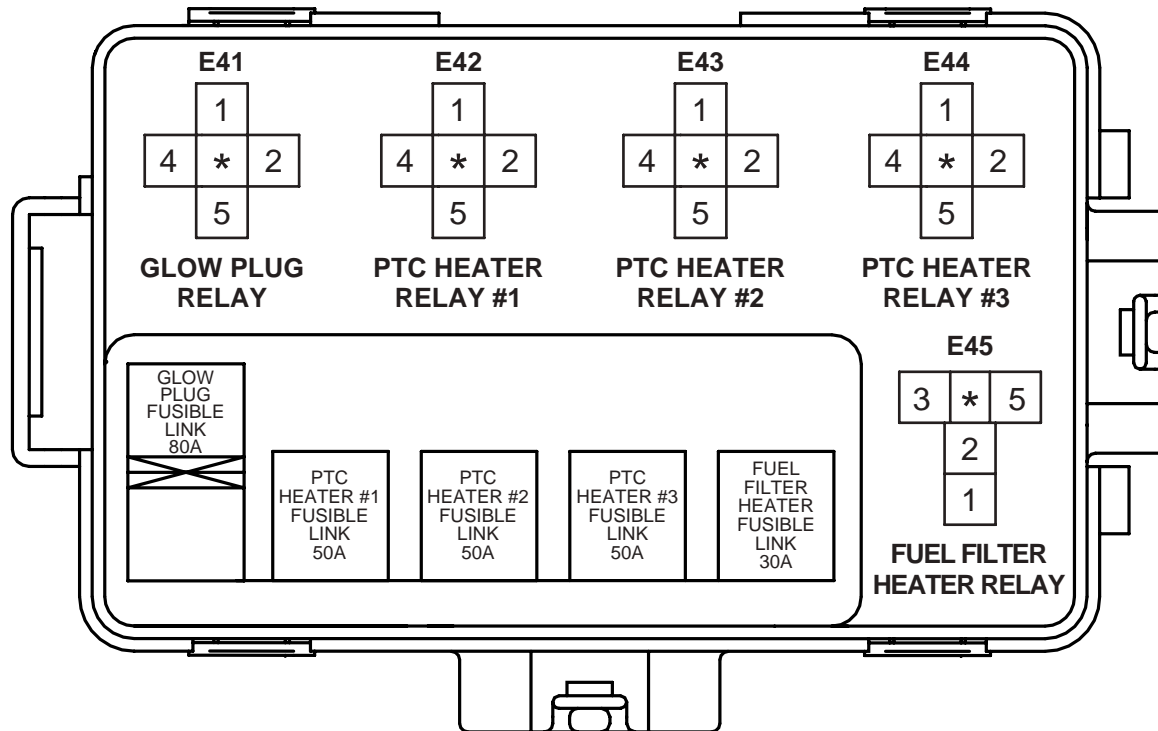

FUSE & RELAY INFORMATIONS

FUSE & RELAY INFORMATIONS (6)

SD100-6

MEMO

POWER DISTRIBUTION

E6428AF1

POWER DISTRIBUTION (1)

SD110-1

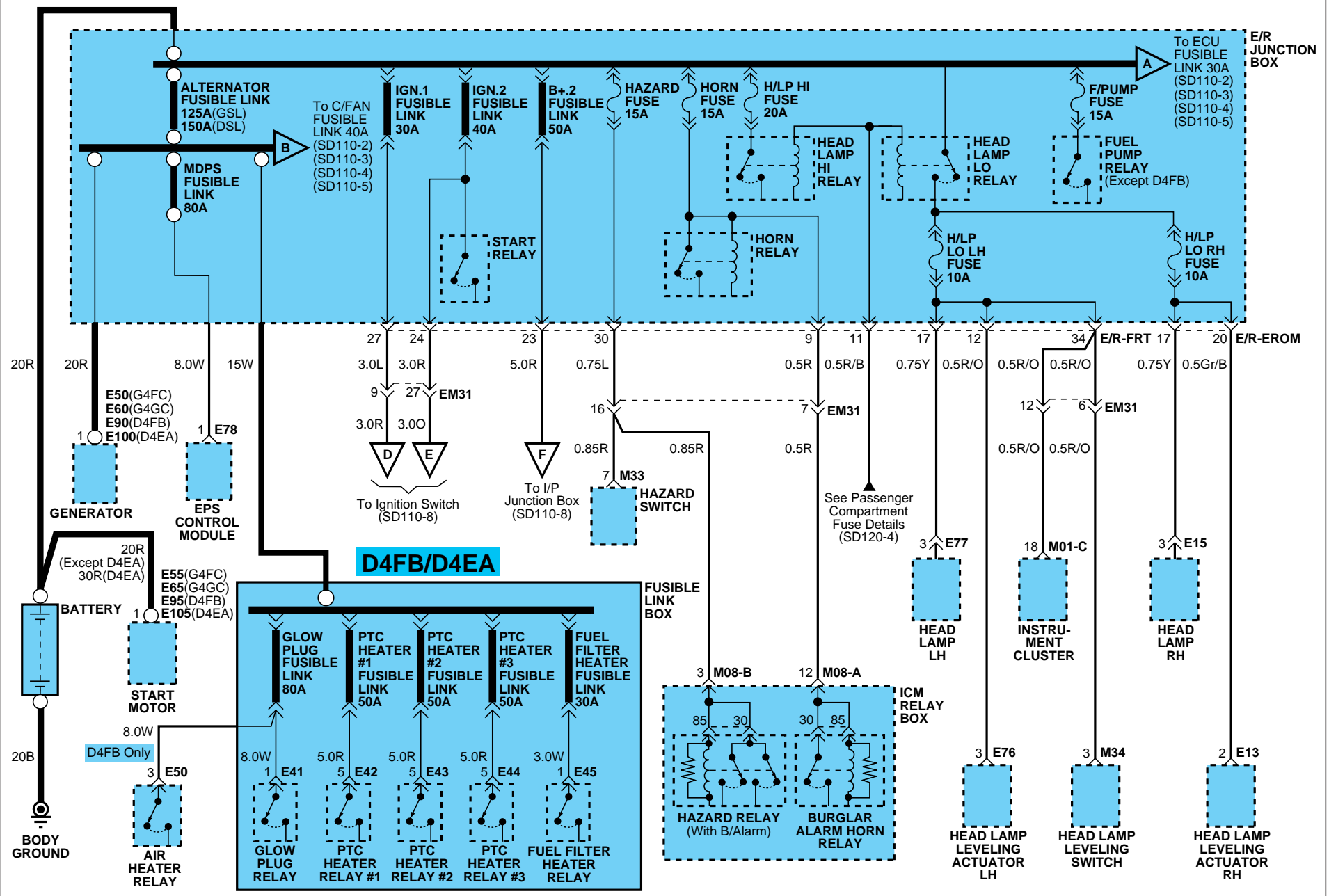

POWER DISTRIBUTION

POWER DISTRIBUTION (2)

SD110-2

G4FC

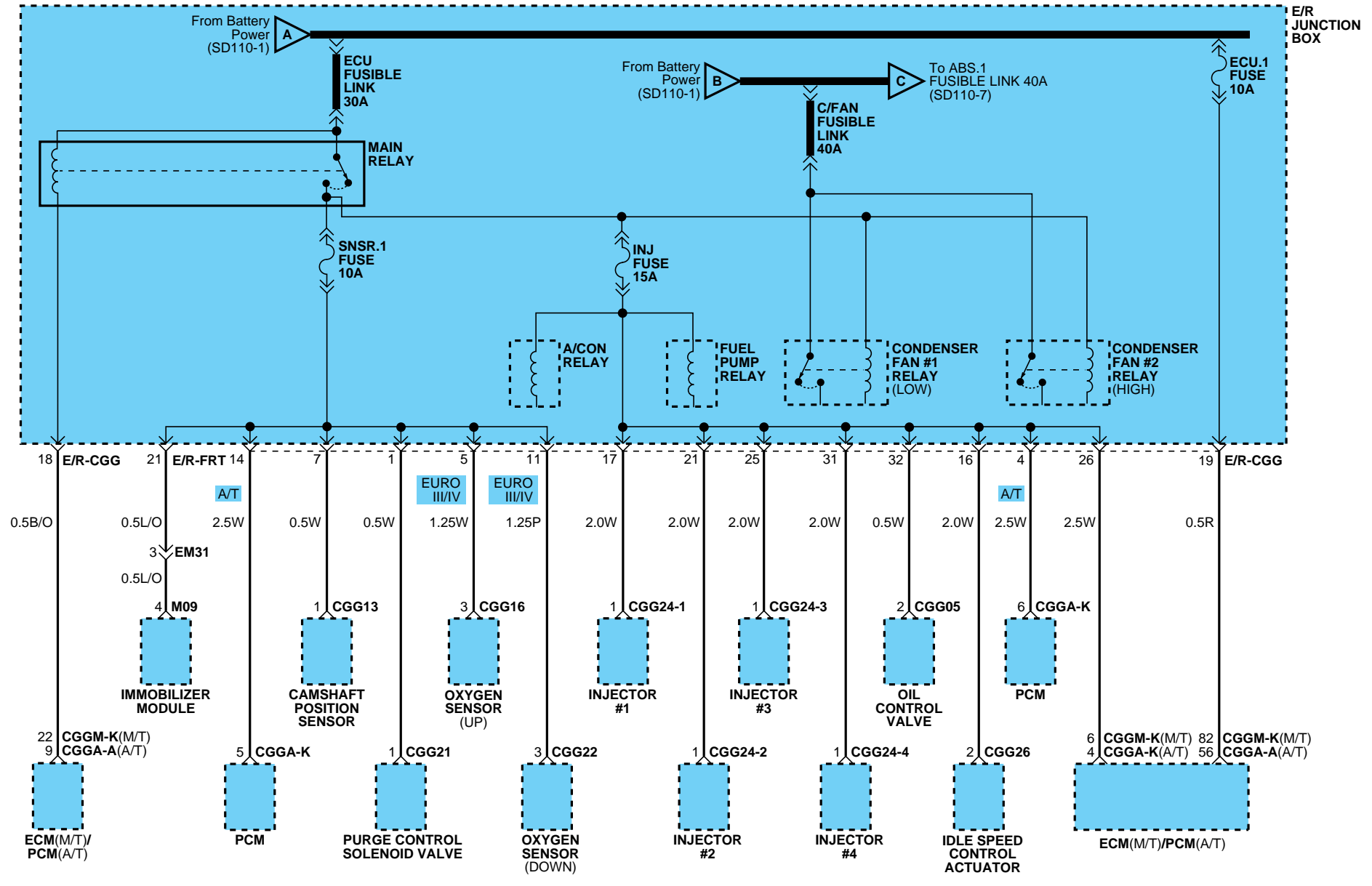

POWER DISTRIBUTION

POWER DISTRIBUTION (3)

SD110-3

G4GC

E/R JUNCTION BOX

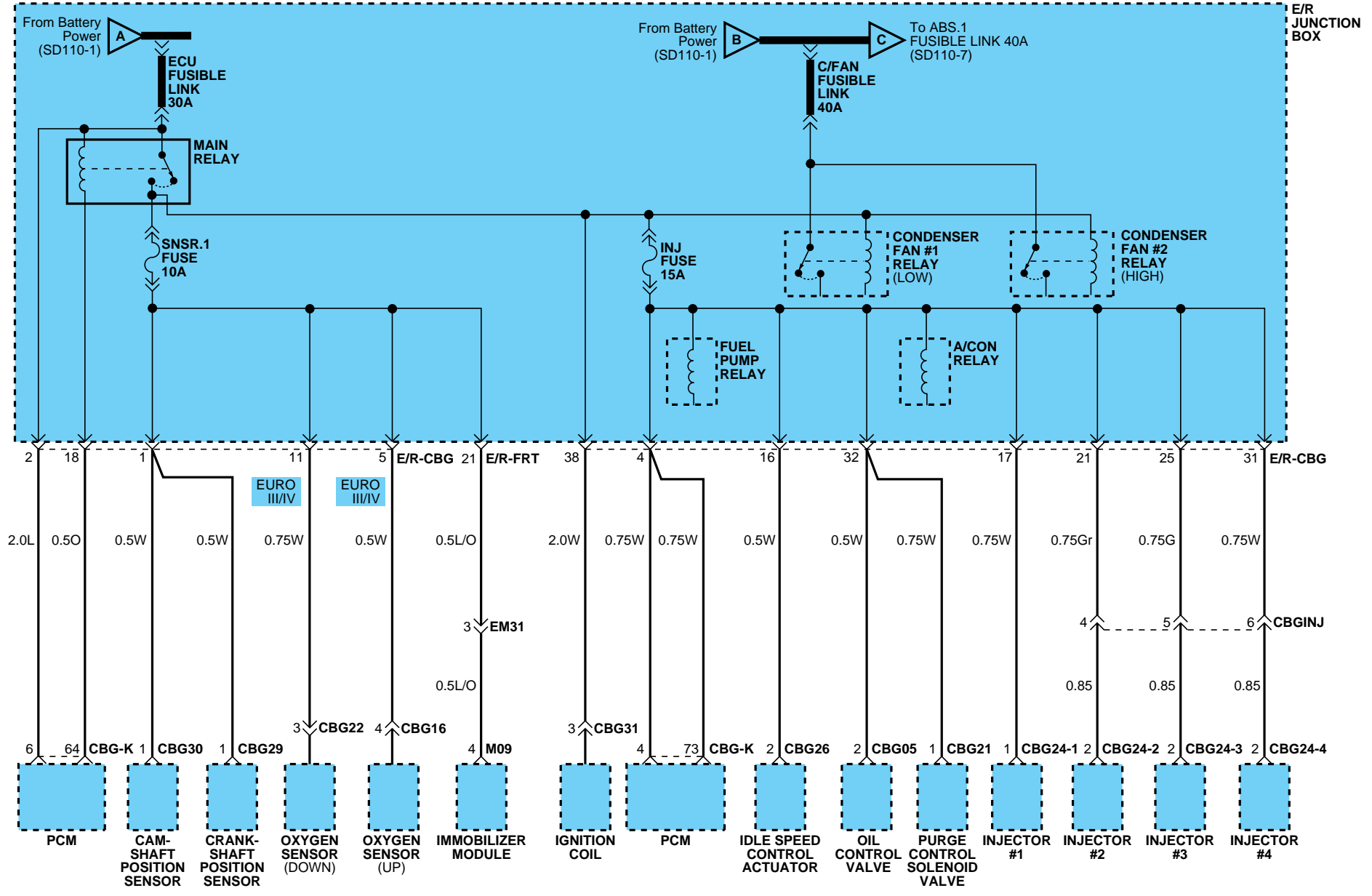

POWER DISTRIBUTION

POWER DISTRIBUTION (4)

SD110-4

D4FB

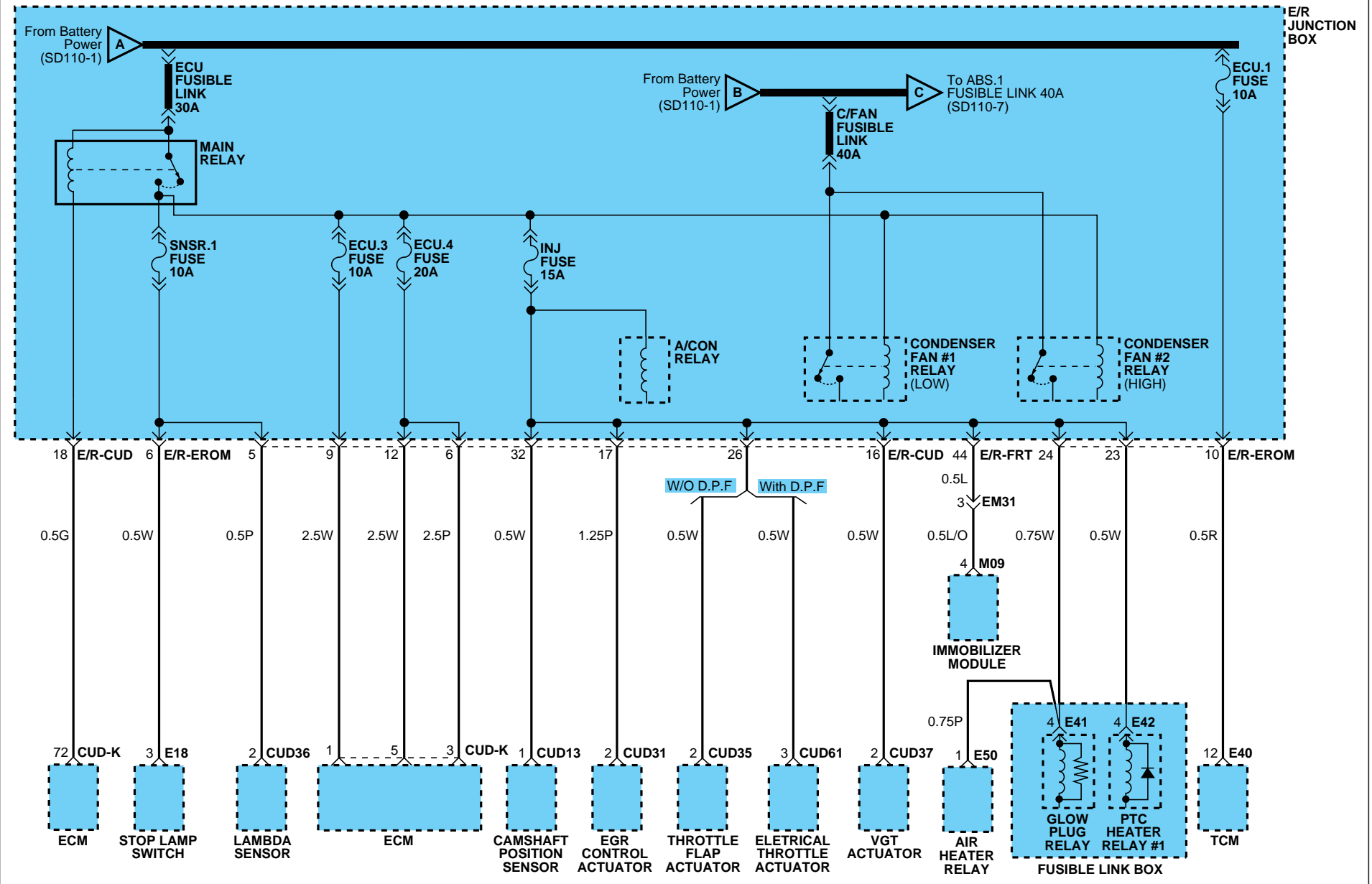

POWER DISTRIBUTION

POWER DISTRIBUTION (5)

SD110-5

D4EA

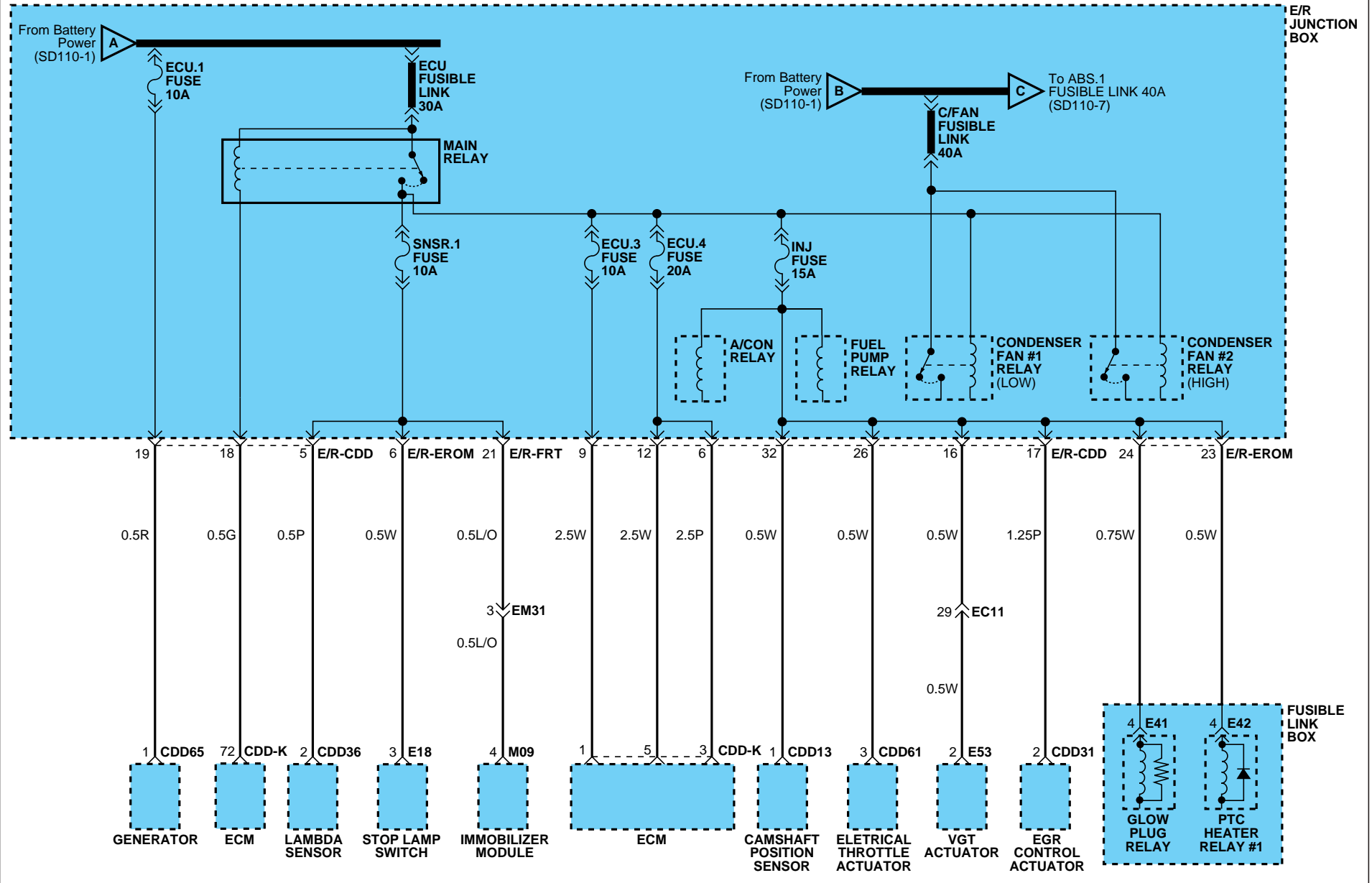

POWER DISTRIBUTION

POWER DISTRIBUTION (6)

SD110-6

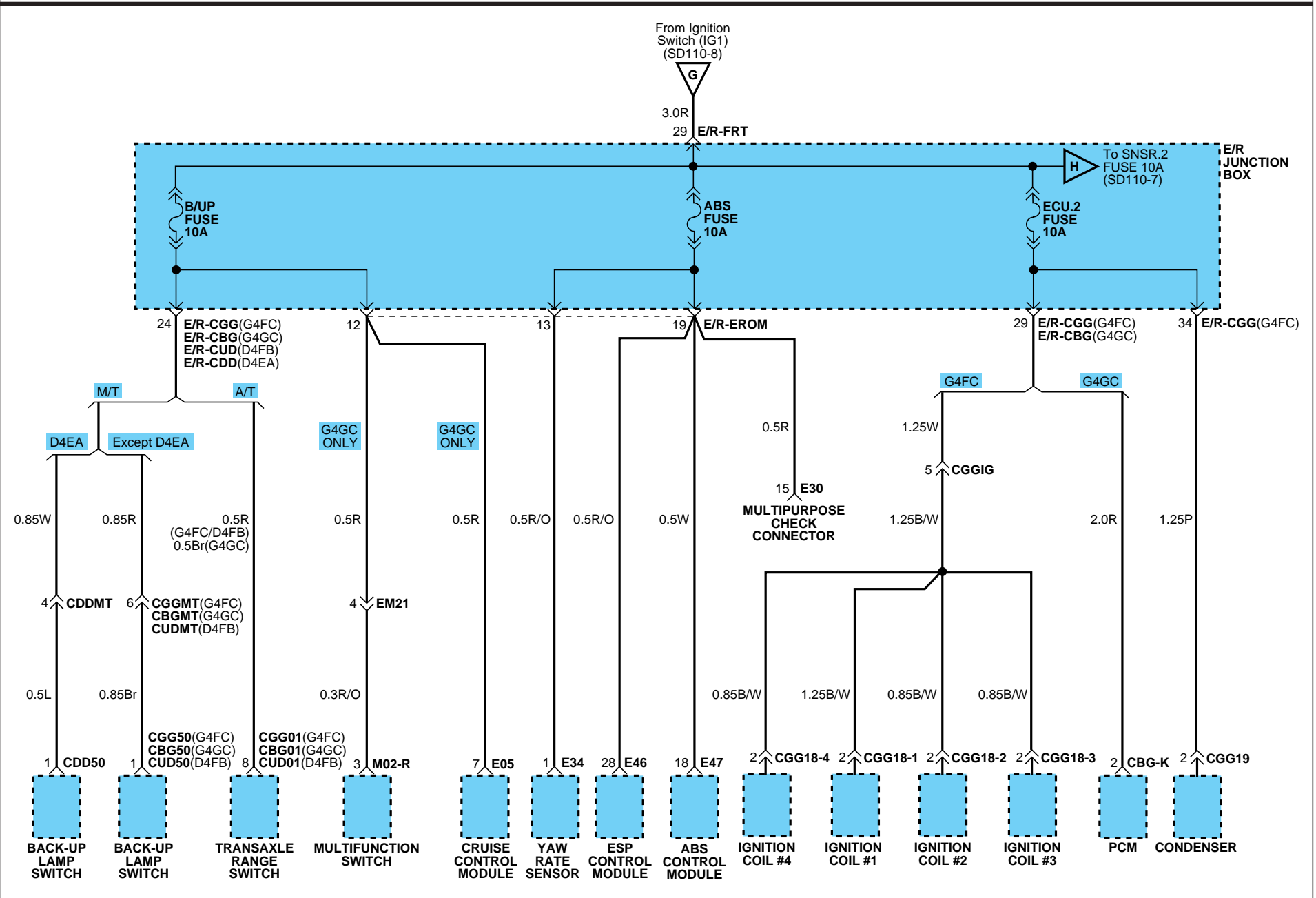

POWER DISTRIBUTION

POWER DISTRIBUTION (7)

SD110-7

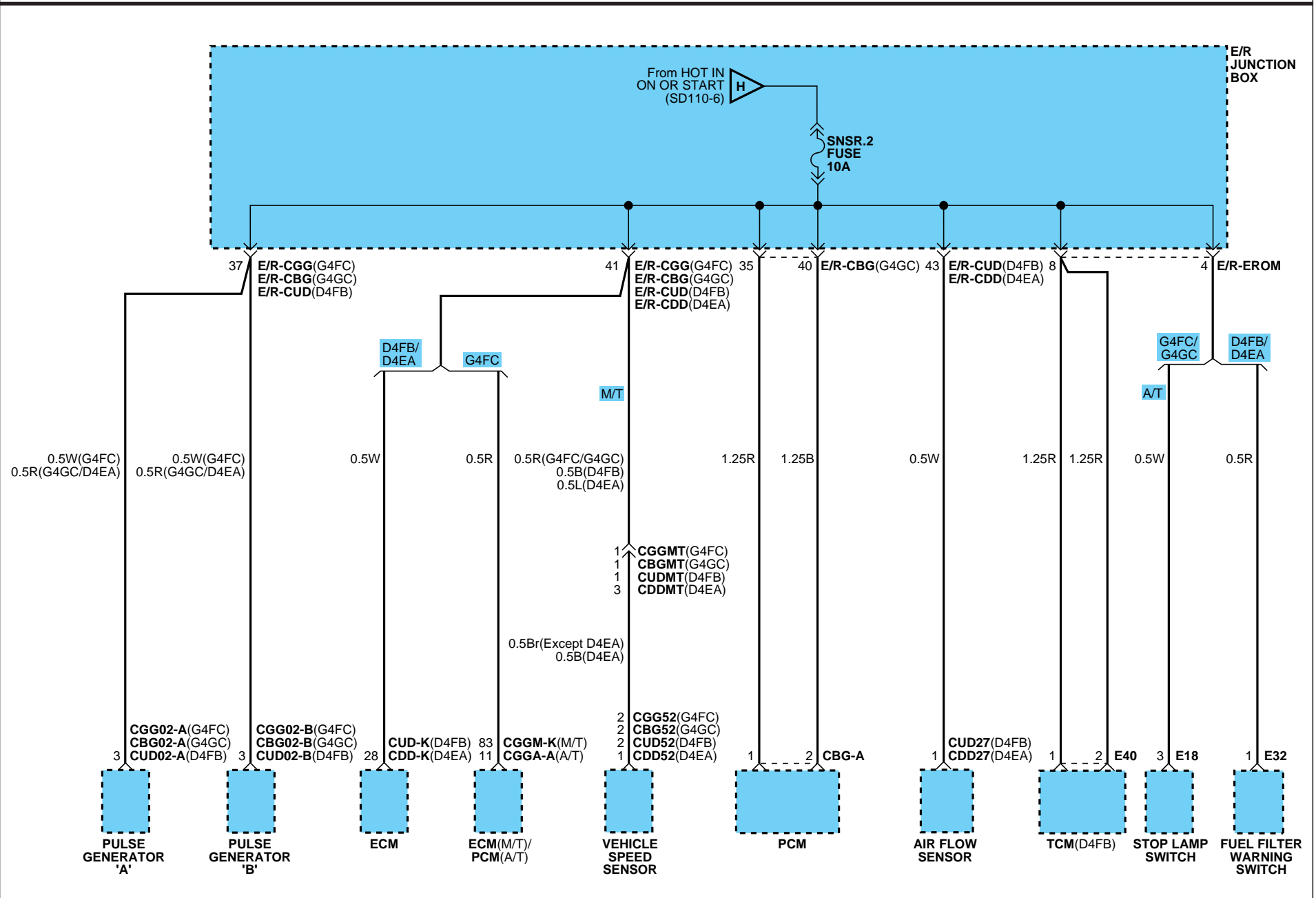

POWER DISTRIBUTION

POWER DISTRIBUTION (8)

SD110-8

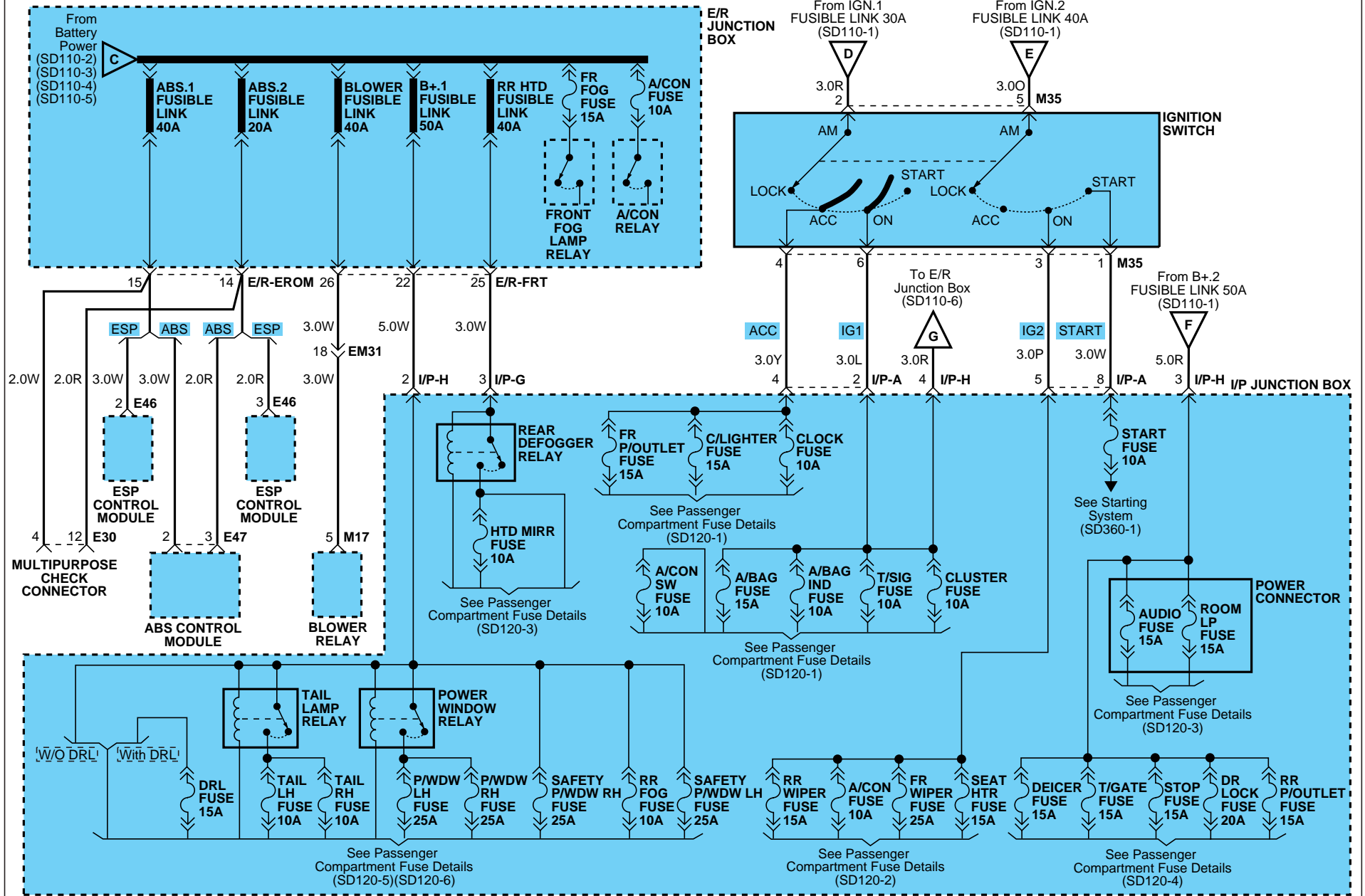

PASSENGER COMPARTMENT FUSE DETAILS (1)

SD120-1

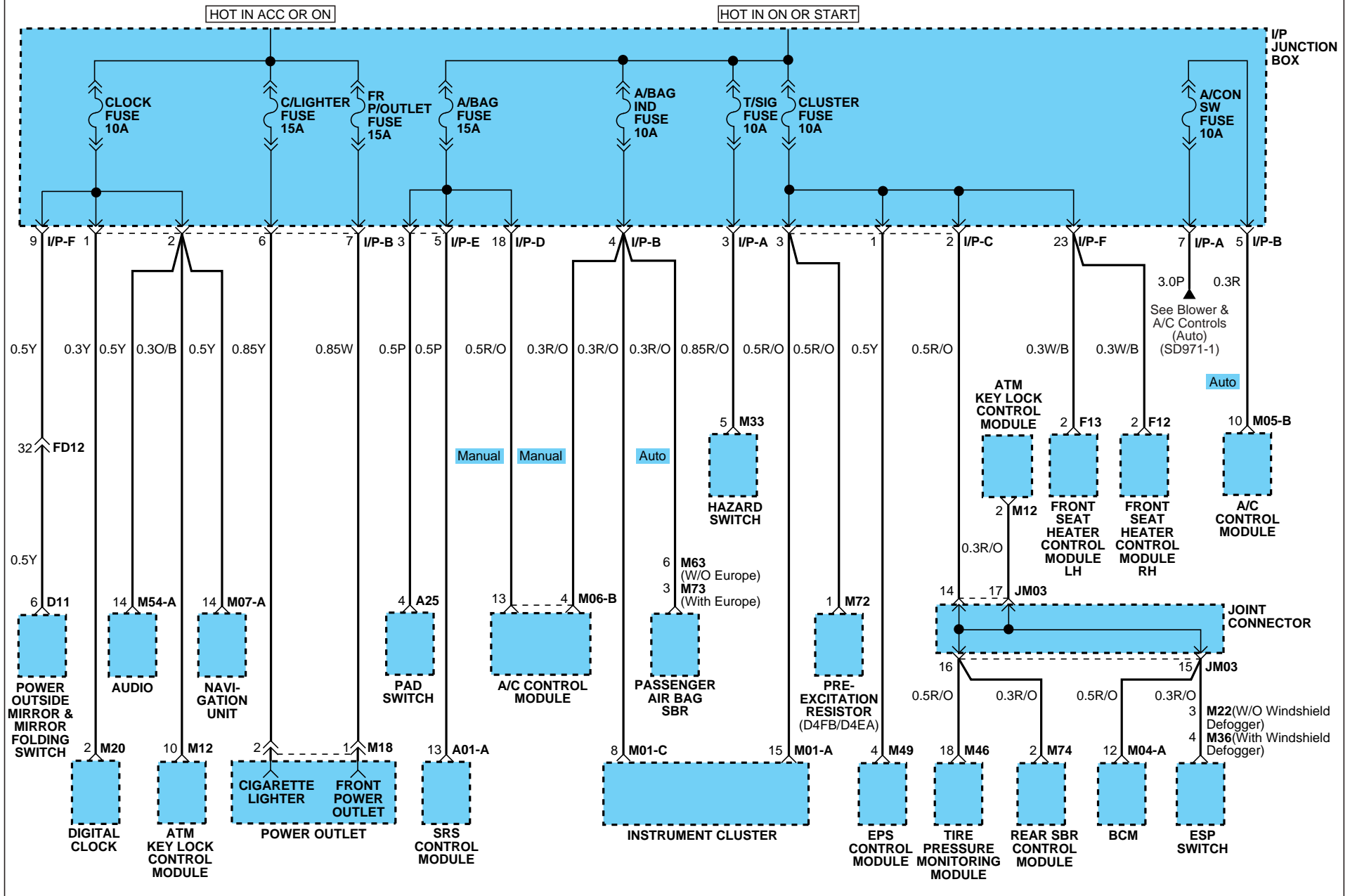

PASSENGER COMPARTMENT FUSE DETAILS

PASSENGER COMPARTMENT FUSE DETAILS (2)

SD120-2

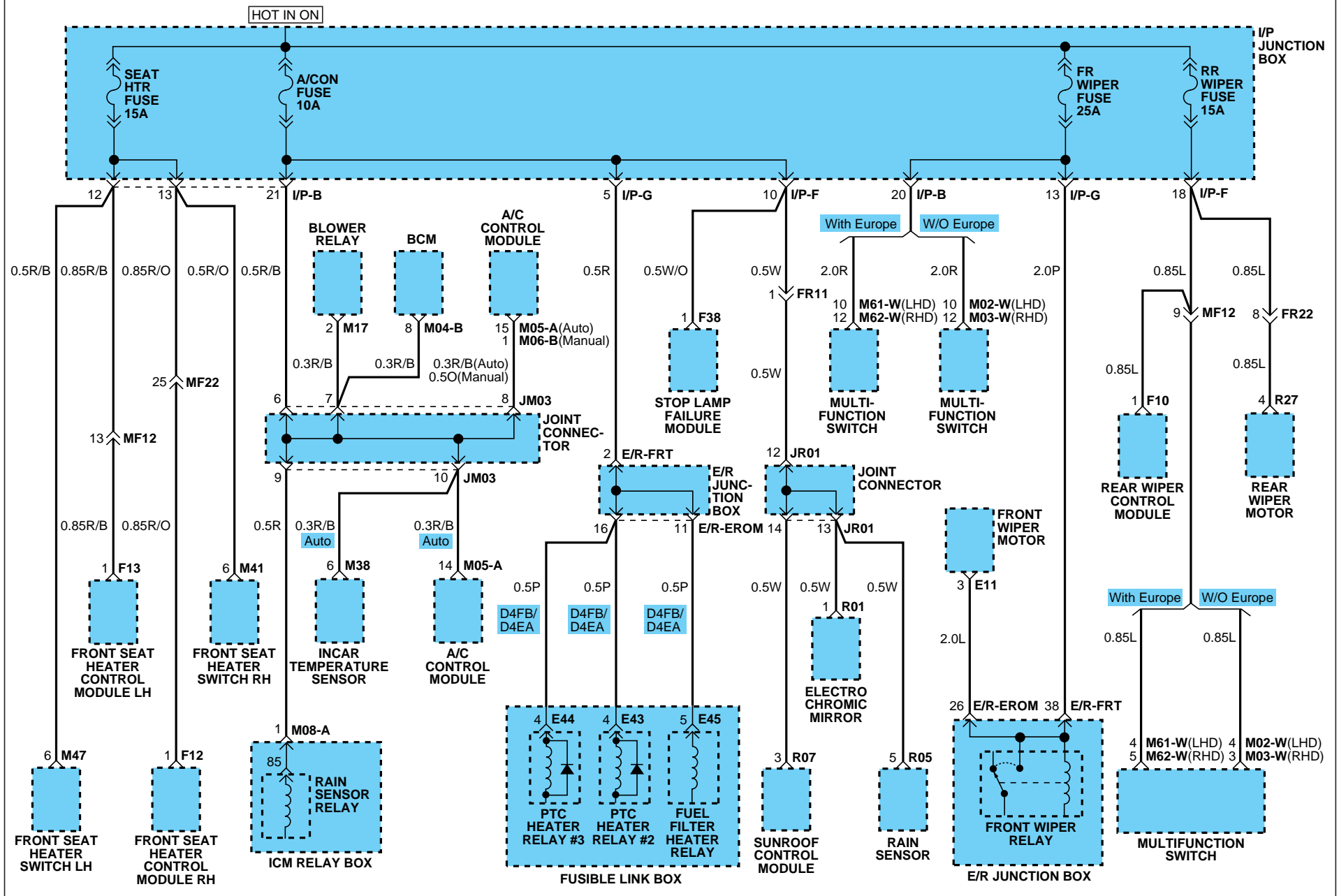

PASSENGER COMPARTMENT FUSE DETAILS

PASSENGER COMPARTMENT FUSE DETAILS (3)

SD120-3

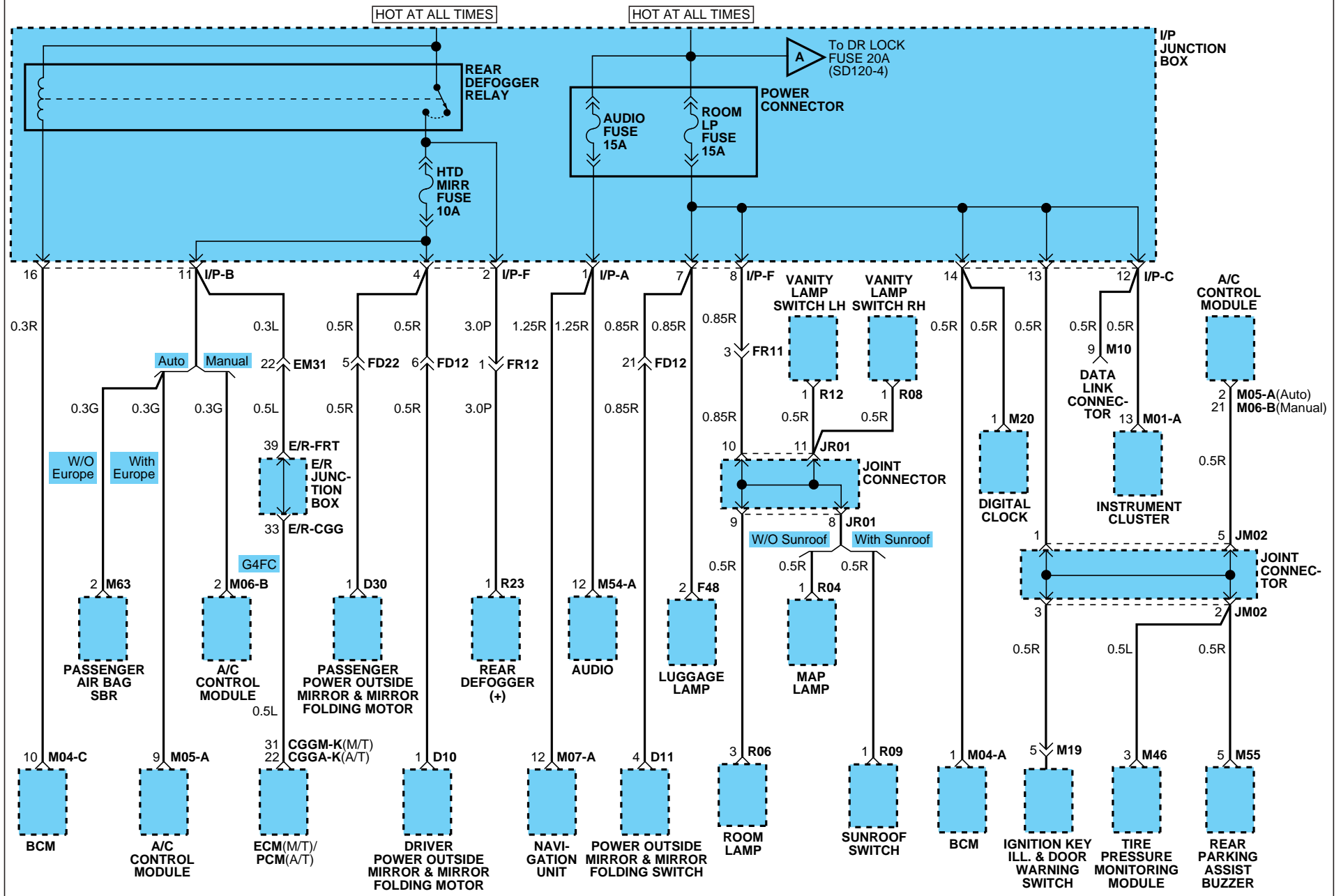

PASSENGER COMPARTMENT FUSE DETAILS

PASSENGER COMPARTMENT FUSE DETAILS (4)

SD120-4

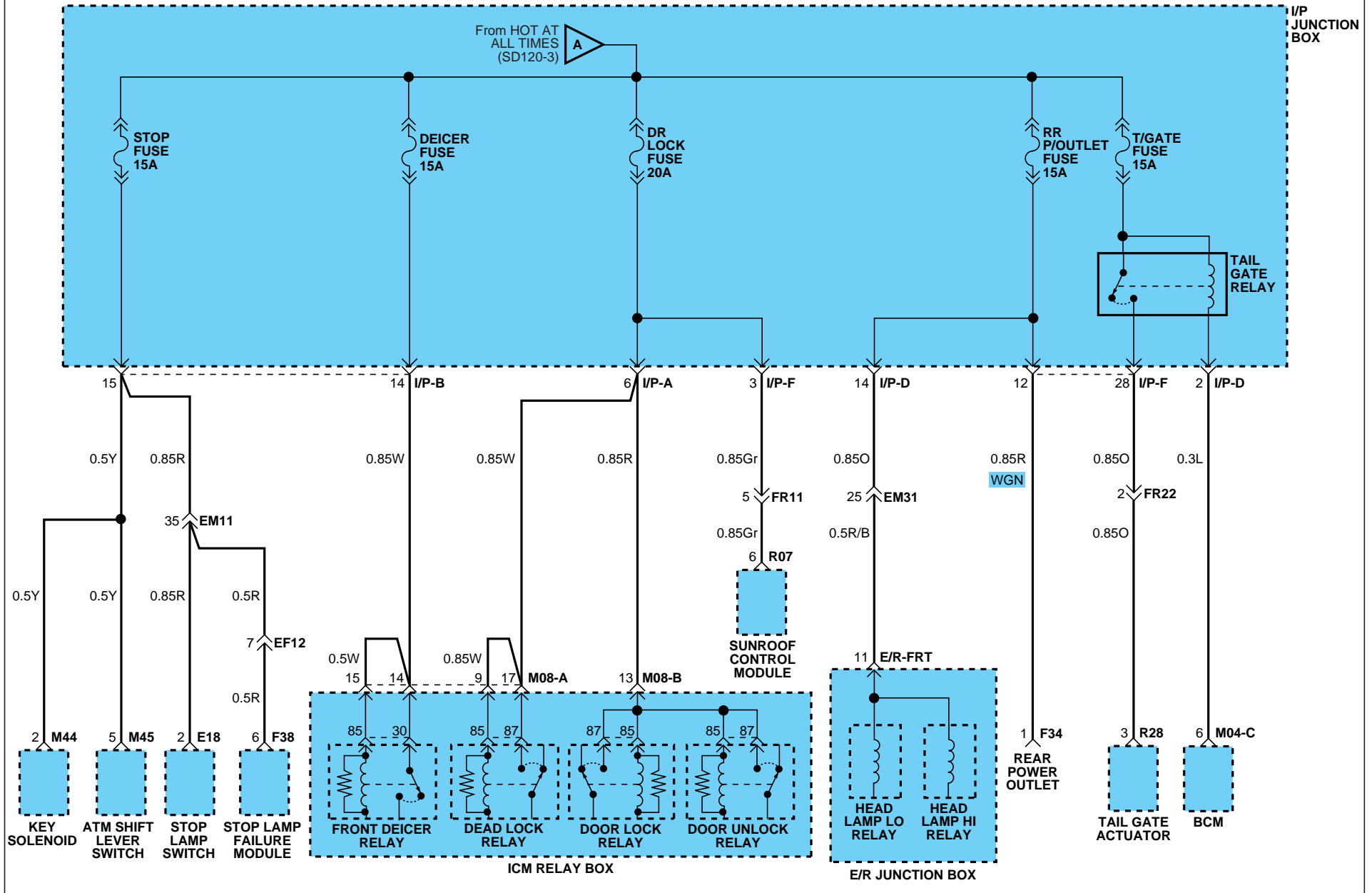

PASSENGER COMPARTMENT FUSE DETAILS

PASSENGER COMPARTMENT FUSE DETAILS (5)

SD120-5

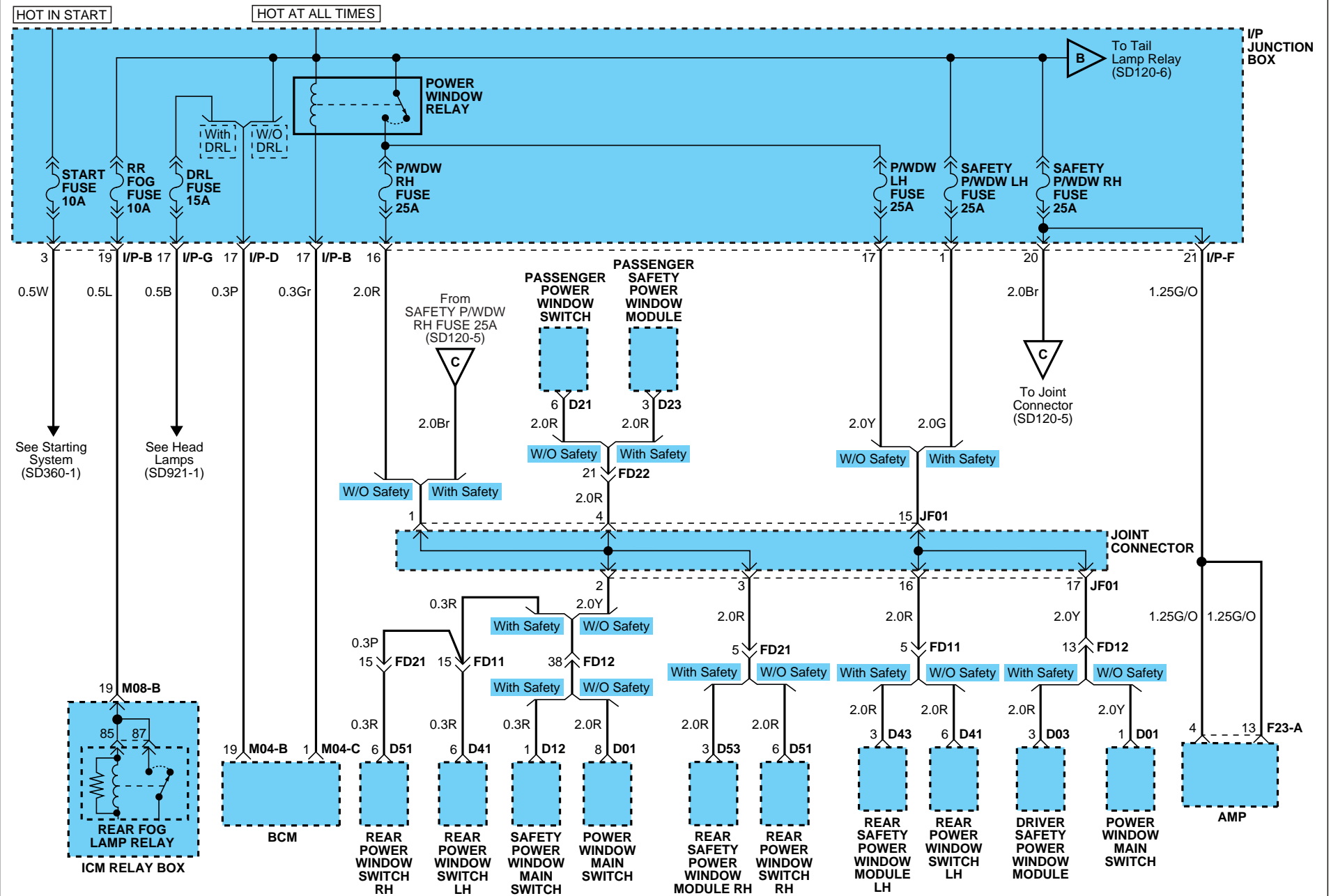

PASSENGER COMPARTMENT FUSE DETAILS

PASSENGER COMPARTMENT FUSE DETAILS (6)

SD120-6

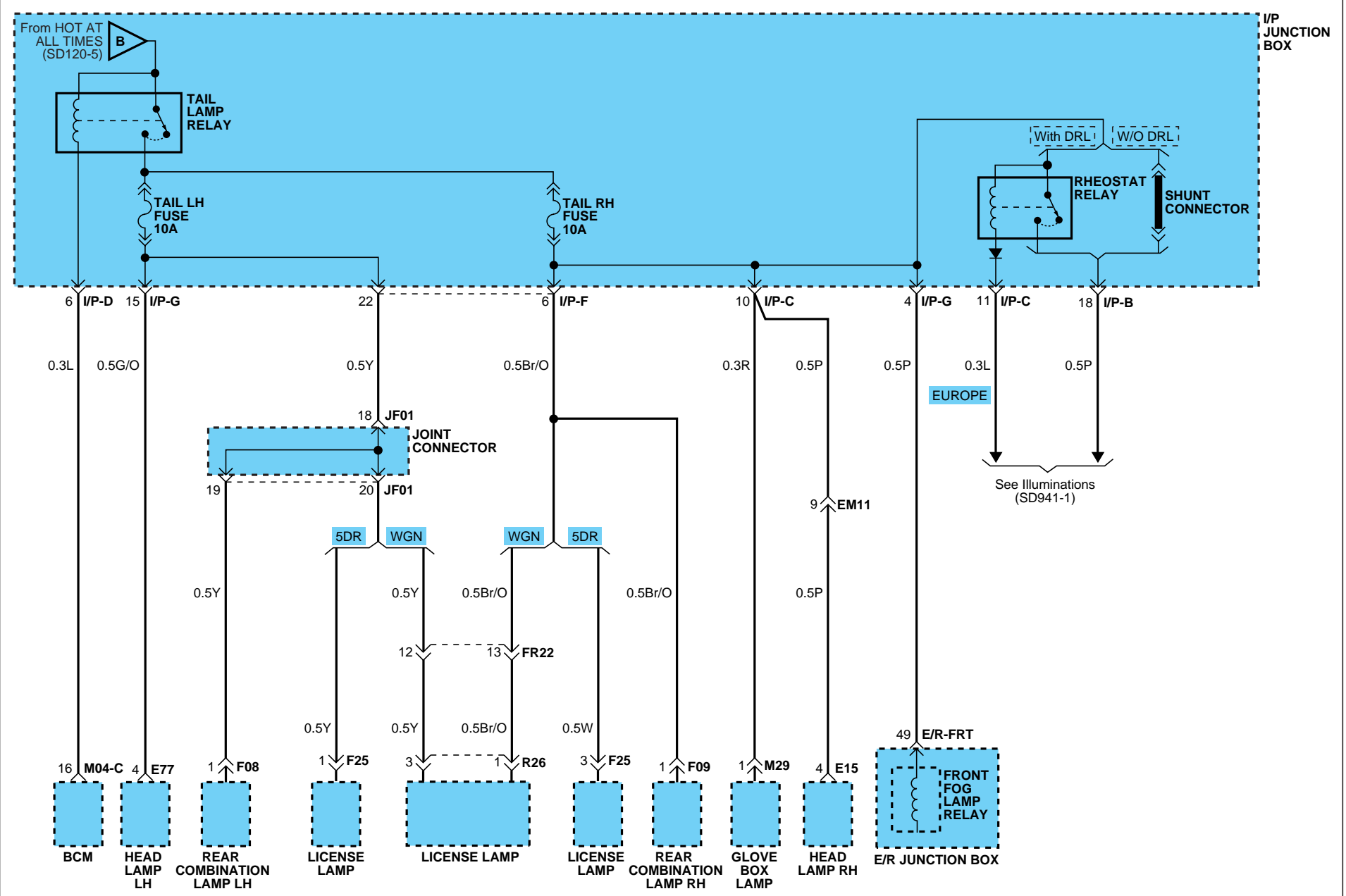

GROUND DISTRIBUTION (1)

SD130-1

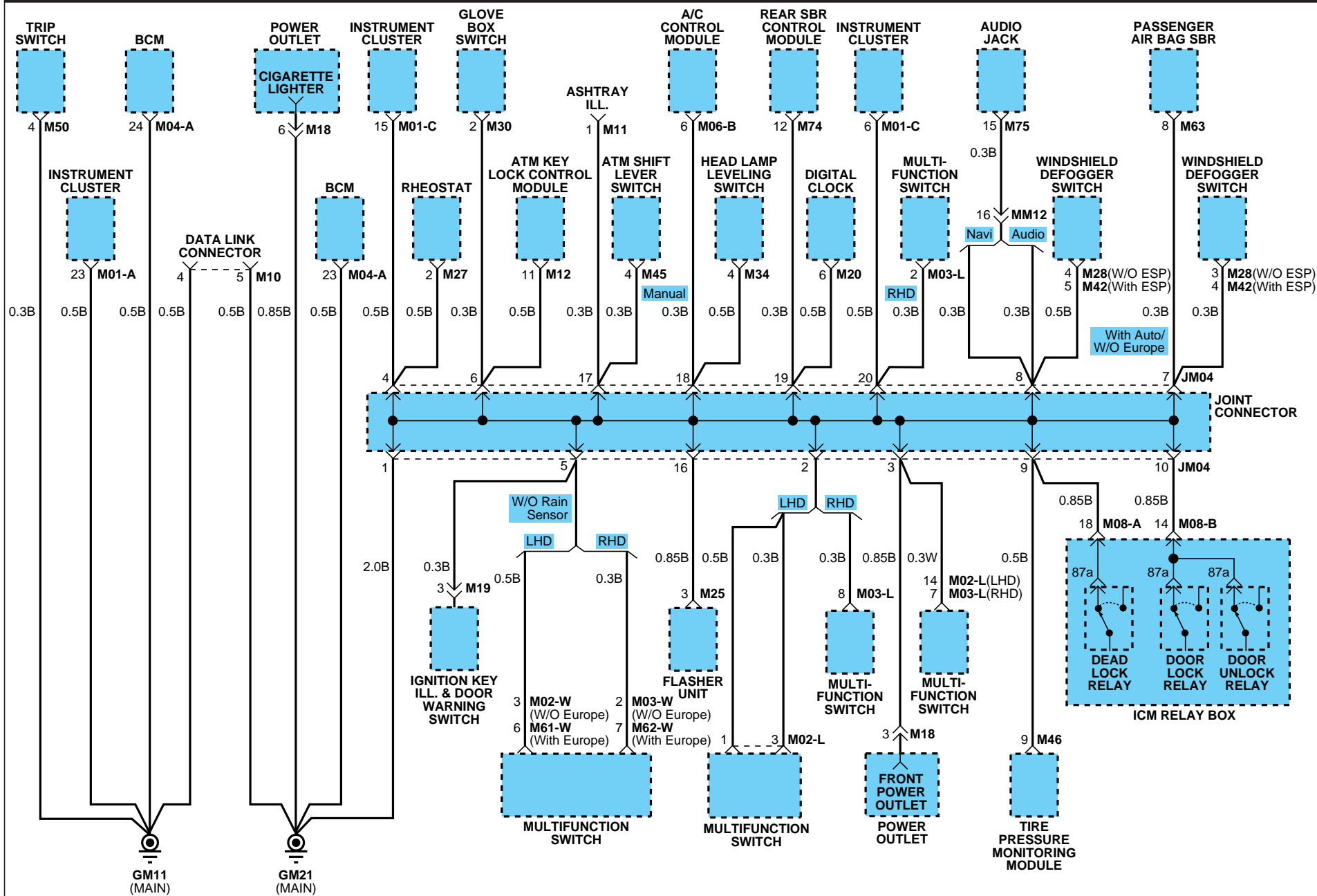

GROUND DISTRIBUTION

GROUND DISTRIBUTION (2)

SD130-2

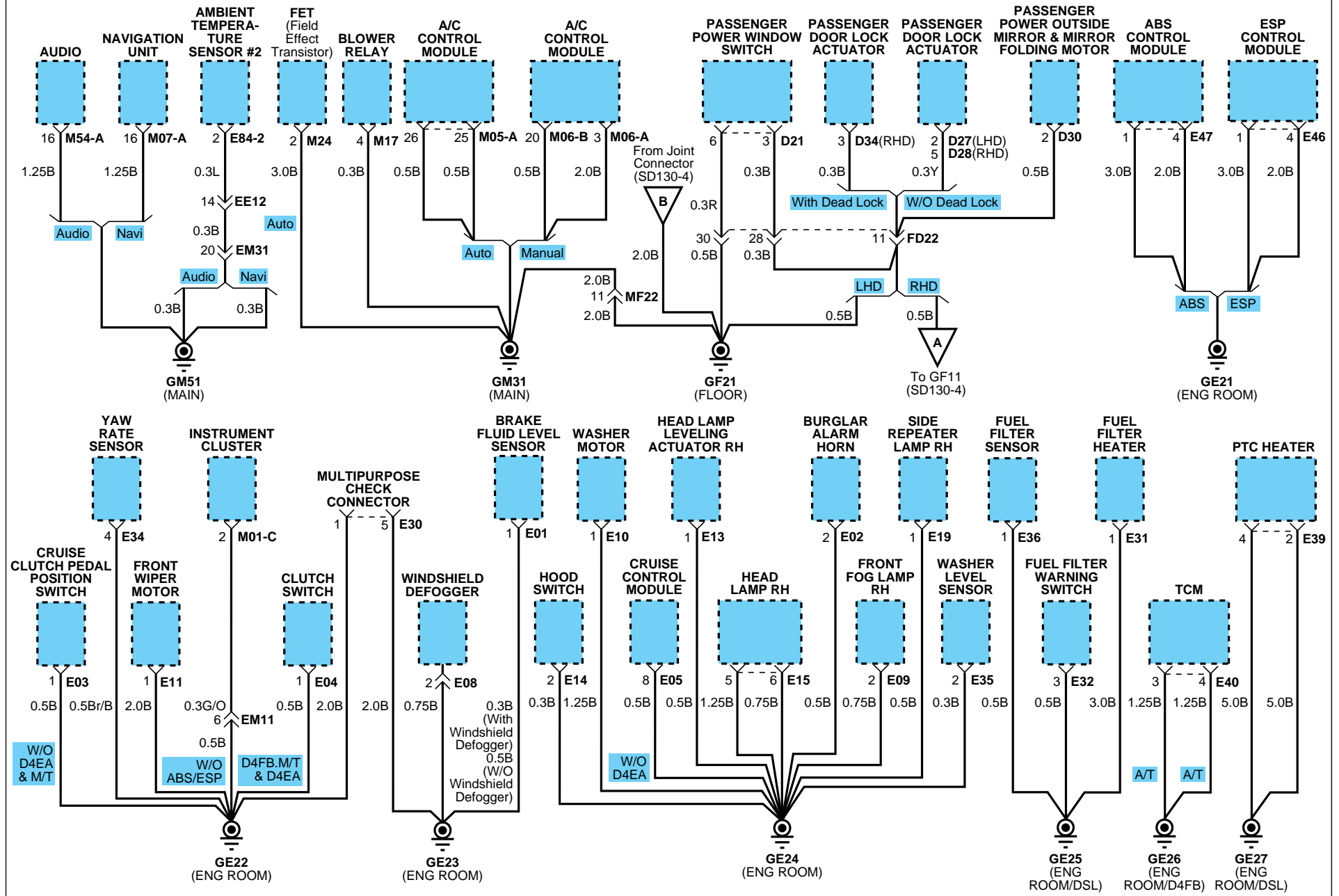

GROUND DISTRIBUTION

GROUND DISTRIBUTION (3)

SD130-3

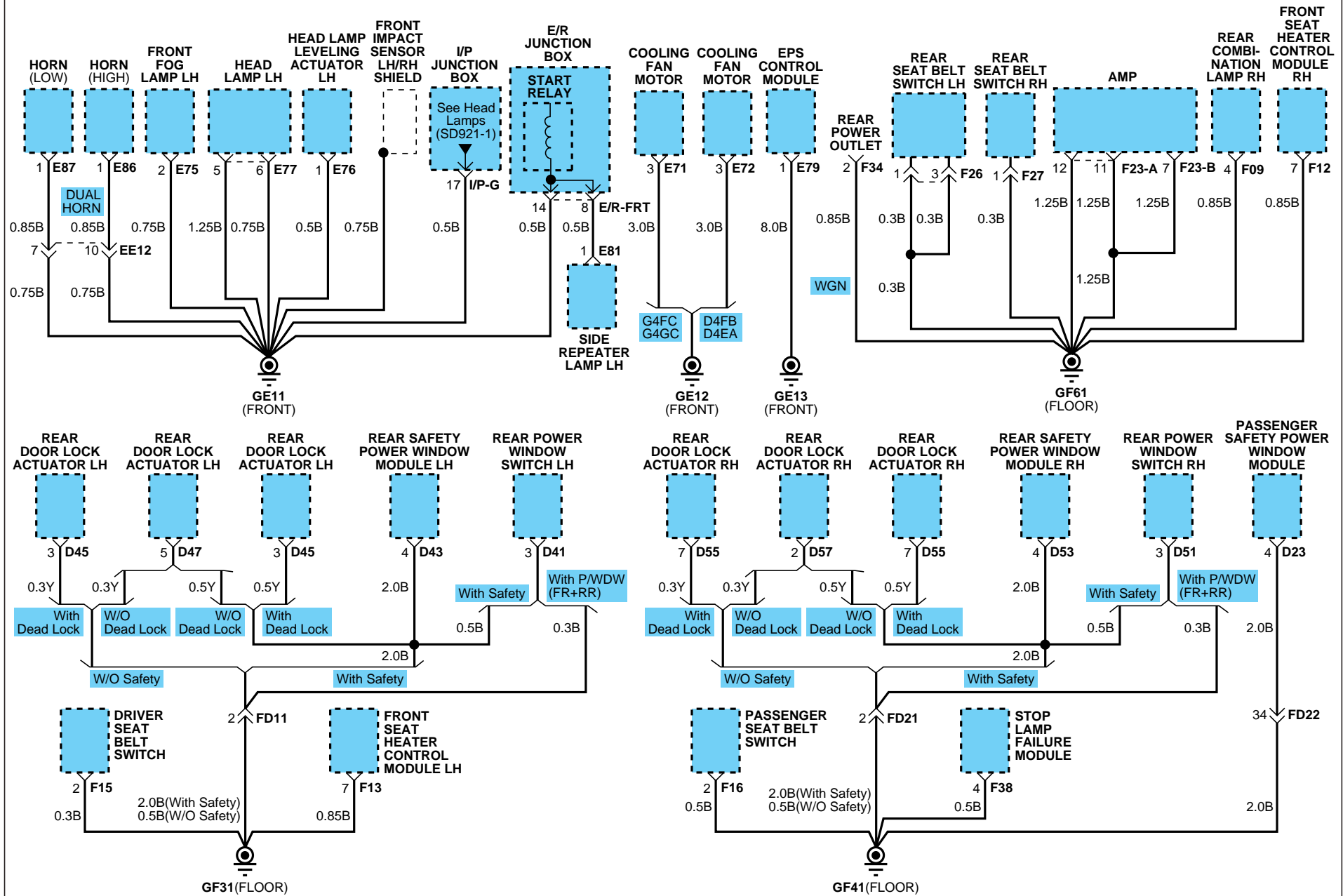

GROUND DISTRIBUTION

GROUND DISTRIBUTION (4)

SD130-4

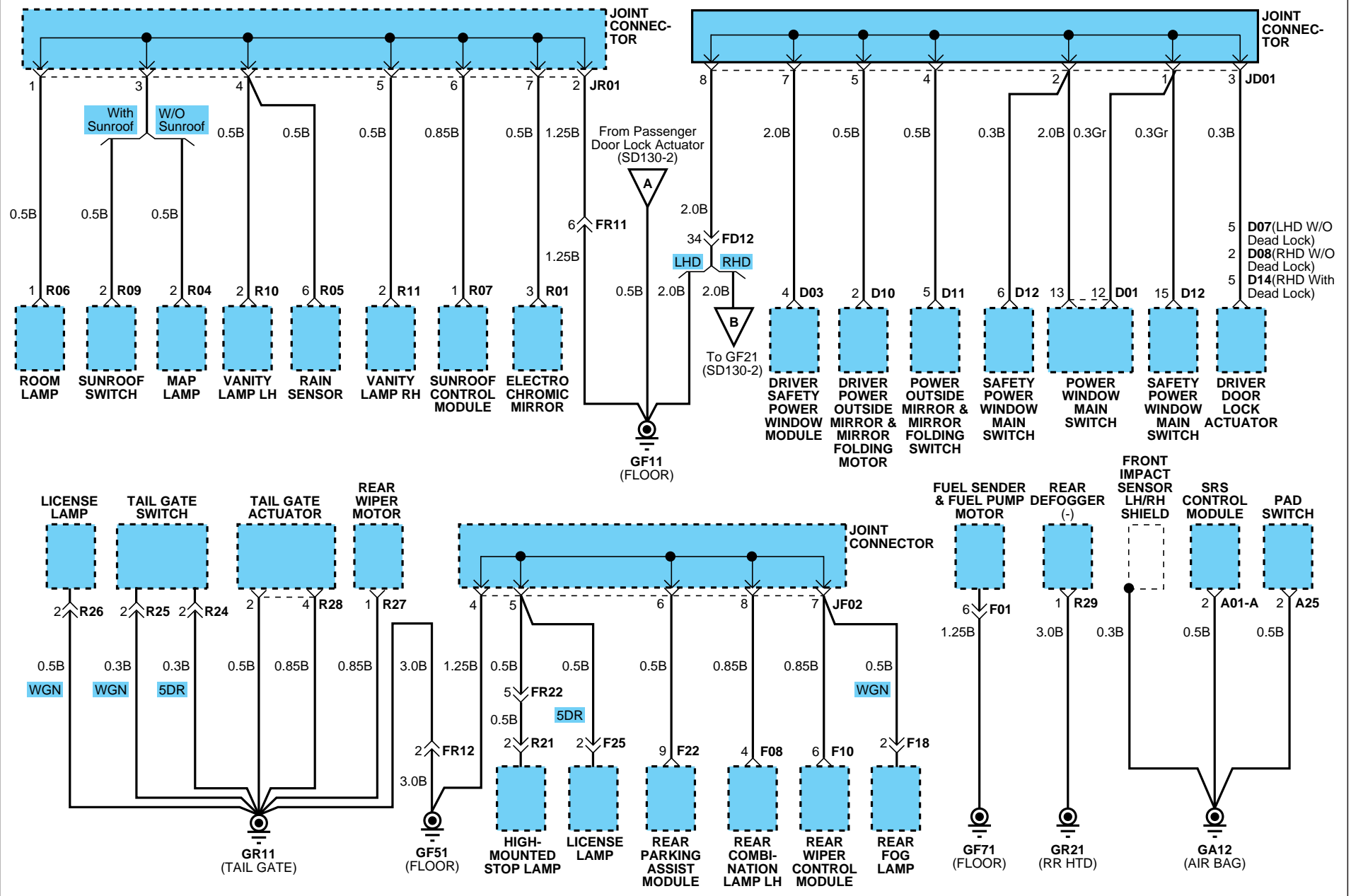

GROUND DISTRIBUTION

GROUND DISTRIBUTION (5)

SD130-5

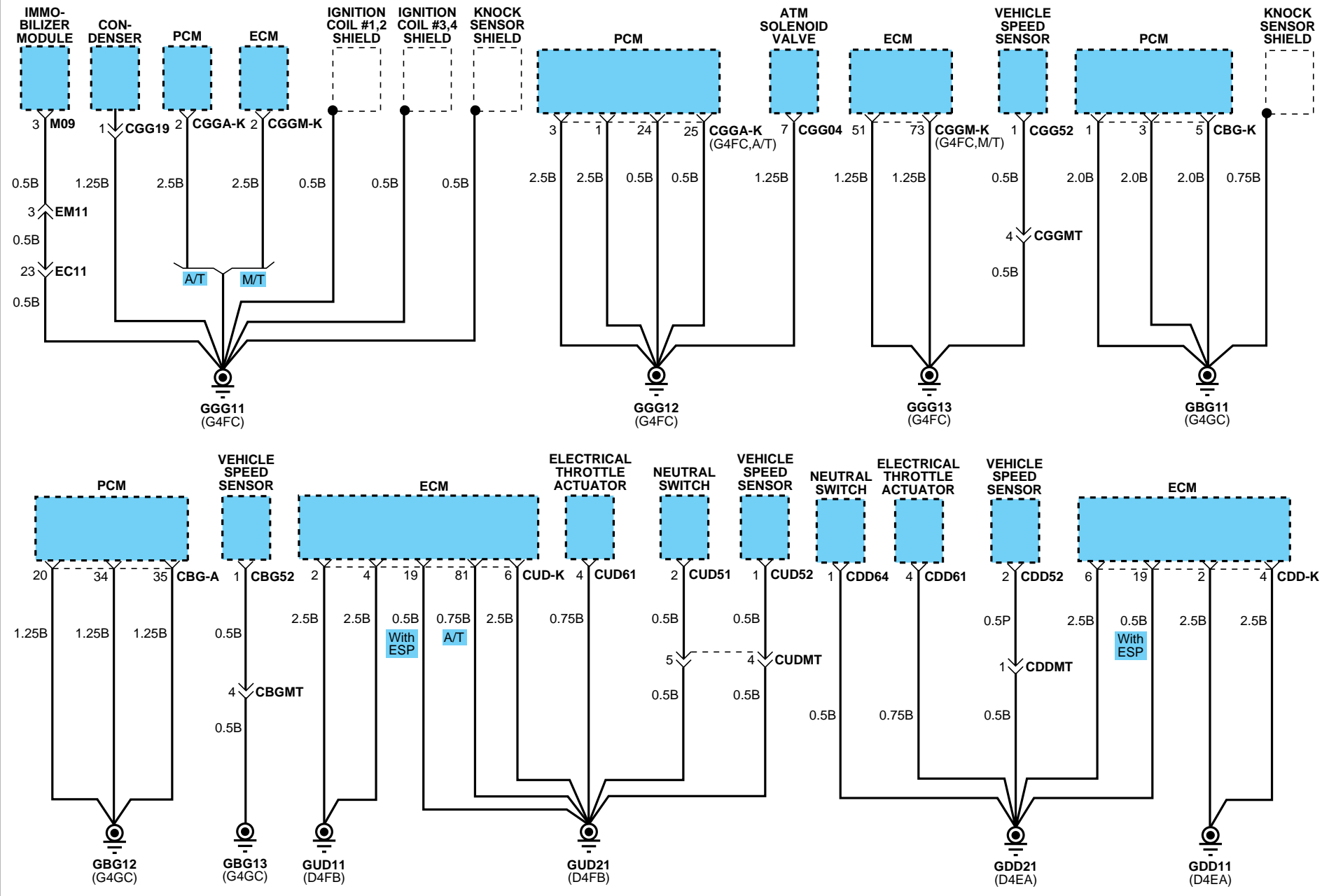

GROUND DISTRIBUTION

GROUND DISTRIBUTION (6)

SD130-6

MEMO

DATA LINK DETAILS (1)

SD200-1

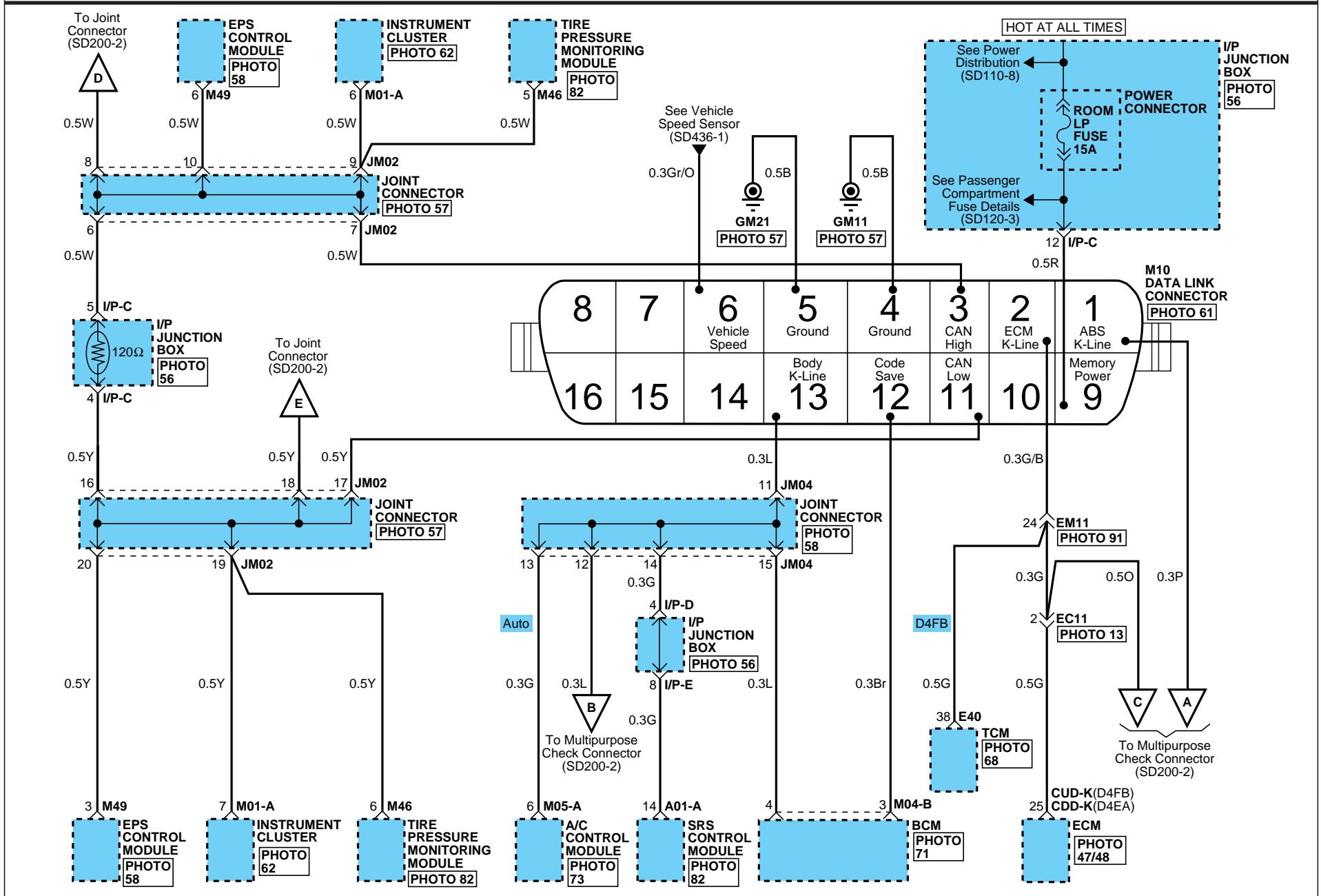

DATA LINK DETAILS

DATA LINK DETAILS (2)

SD200-2

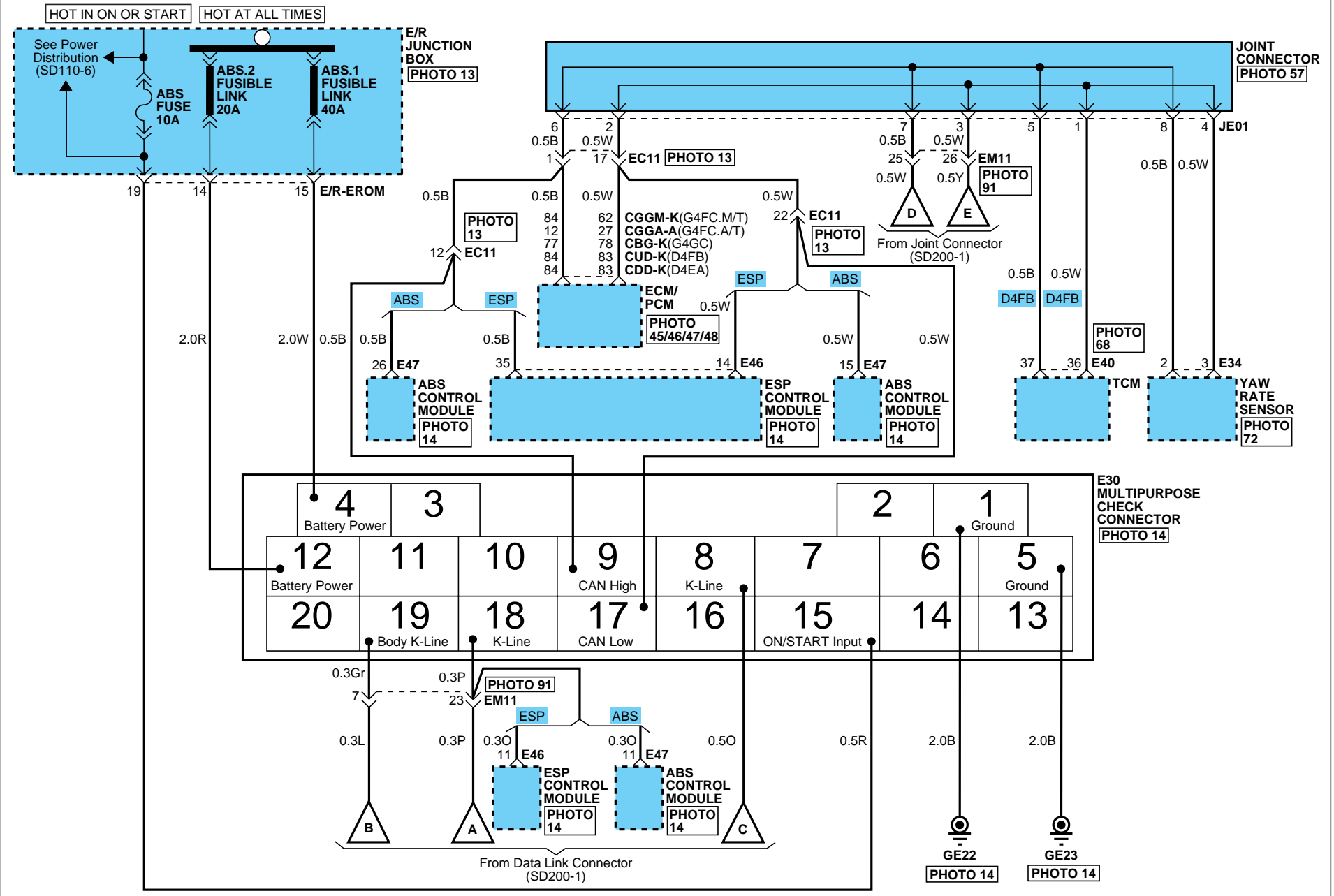

DATA LINK DETAILS

DATA LINK DETAILS (3)

SD200-3

A01-A

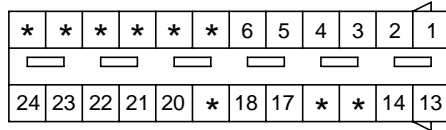

AMP_ABG_24F_B_ECU

CGGA-A

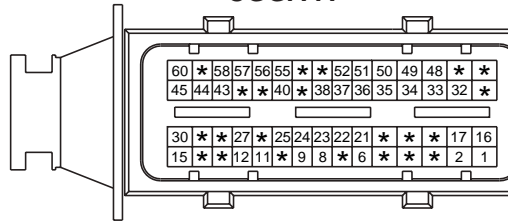

AMP_ECU_60F_B

BLANK

CGGM-K

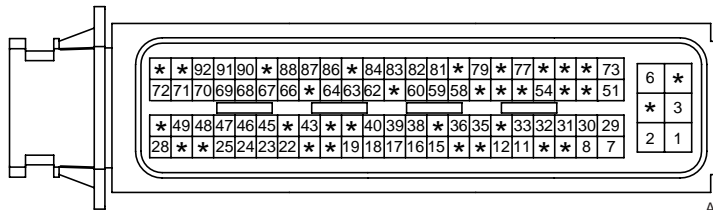

AMP_ECU_94F_B

CBG-K

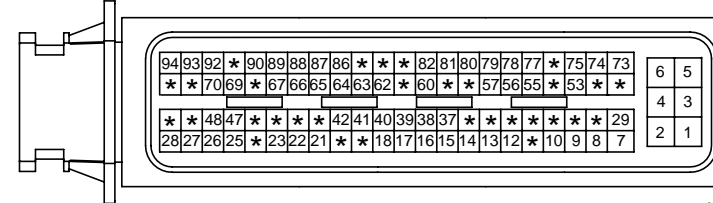

AMP_ECU_94F_B

CUD-K

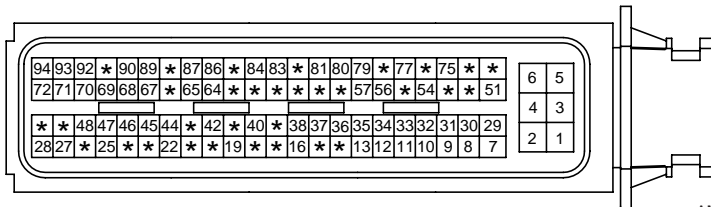

AMP_ECU_94F_B

CDD-K

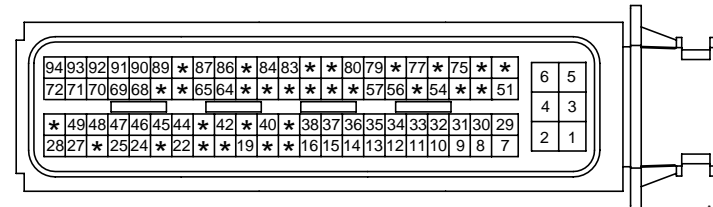

AMP_ECU_94F_B

E30

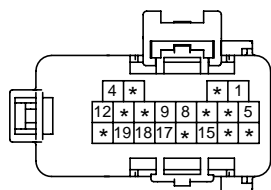

KET_DIAG_20F_B_BRK_C

E34

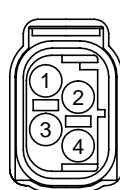

AMP_MQSWP_04F_B

E40

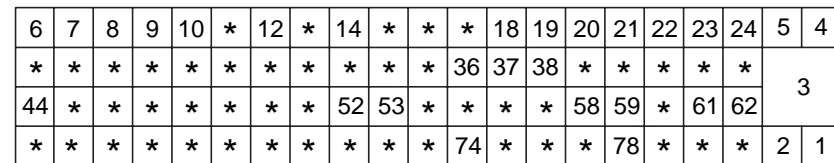

KET_ECU_81F_B_BOSCH

E46

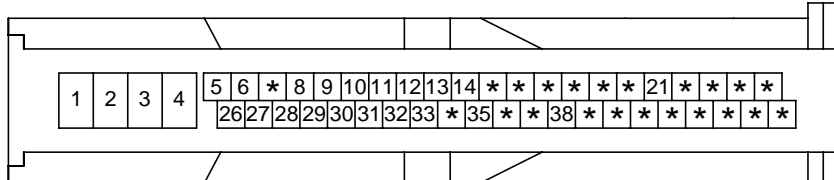

BOS_ESP_46F_B_L

E47

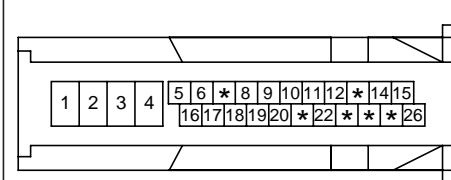

BOS_ABS_26F_B_L

M01-A

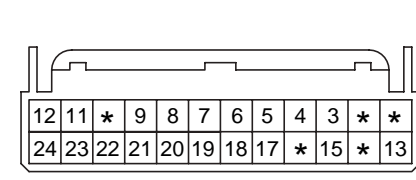

AMP_025_24F_W

DATA LINK DETAILS

DATA LINK DETAILS (4)

SD200-4

M04-B

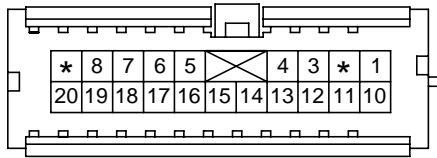

AMP_040III_20F_W

M05-A

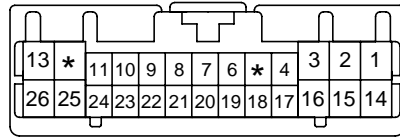

KET_0407_26F_W

M10

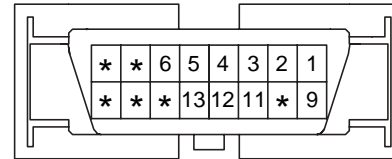

MLX_OBDII_16F_B

M46

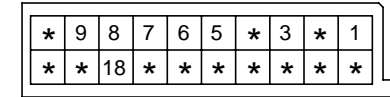

AMP_MQS_20F_B_GH

M49

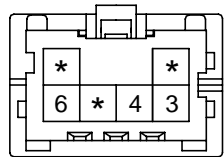

KET_040III_06F_W

BLANK

BLANK

BLANK

COOLING SYSTEM

EABB9247

COOLING SYSTEM (1)

SD253-1

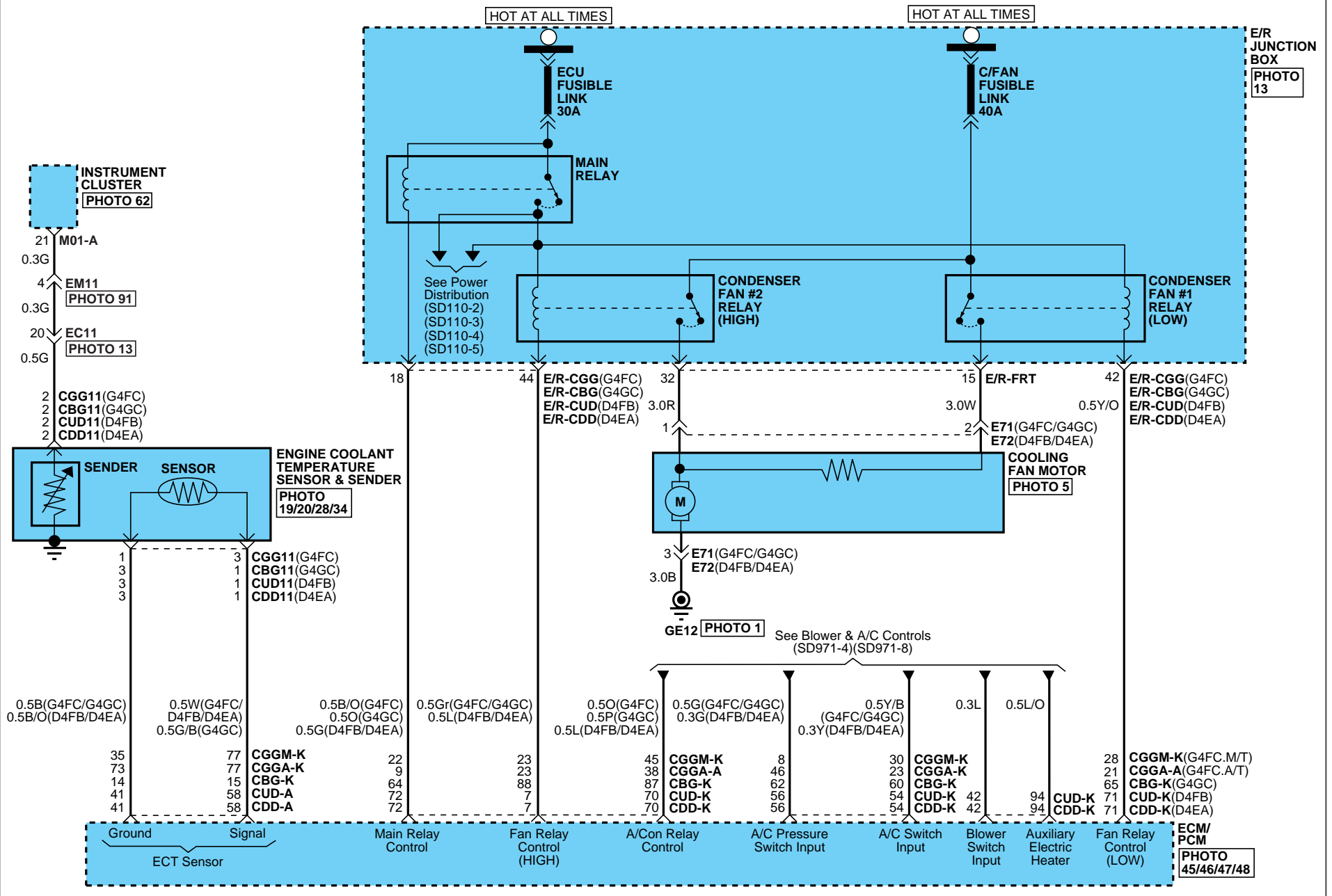

COOLING SYSTEM

COOLING SYSTEM (2)

SD253-2

CGGA-A

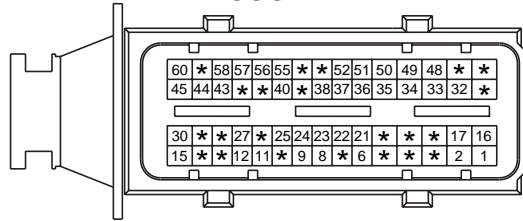

AMP_ECU_60F_B

CGGA-K

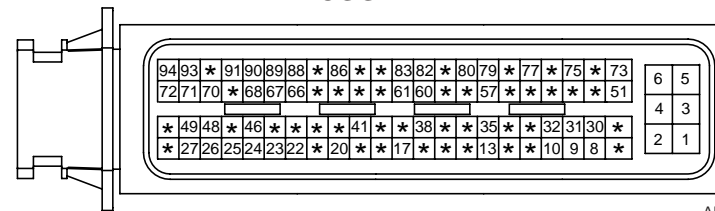

AMP_ECU_94F_B

CGGM-K

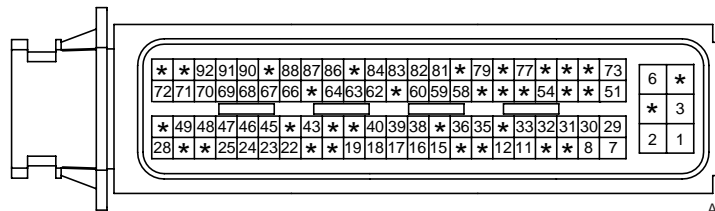

AMP_ECU_94F_B

CBG-K

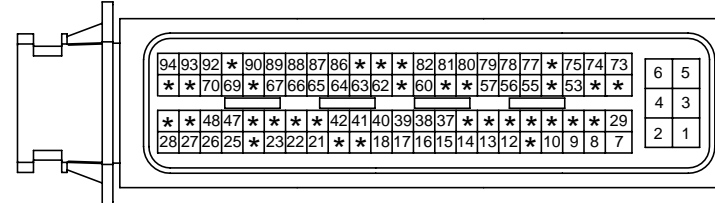

AMP_ECU_94F_B

CUD-A

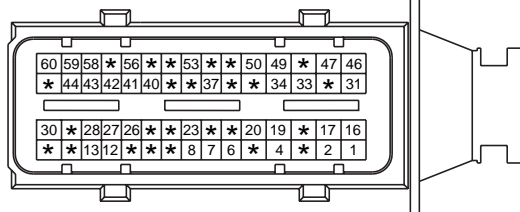

AMP_ECU_60F_B

CUD-K

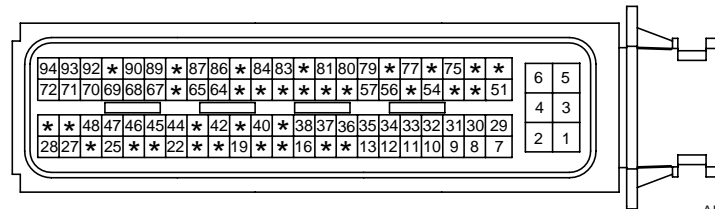

AMP_ECU_94F_B

CDD-A

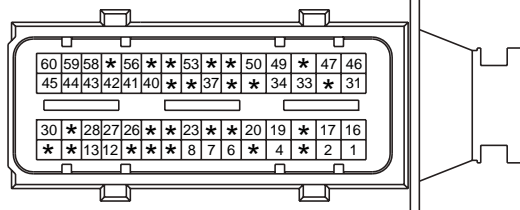

AMP_ECU_60F_B

CDD-K

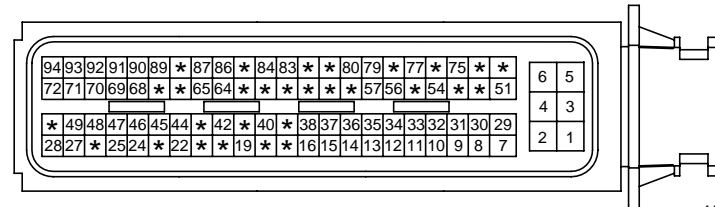

AMP_ECU_94F_B

CGG11/CBG11

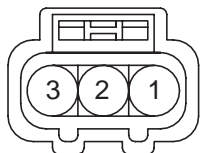

KUM_62Z_03F_B_WTS

CUD11/CDD11

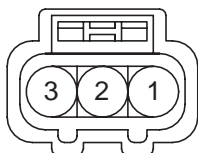

KUM_62Z_03F_B_WTS

E71/E72

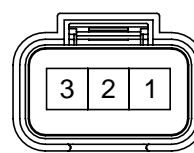

AMP_SPTWP_03F_B

M01-A

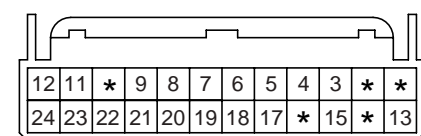

AMP_025_24F_W

MFI CONTROL SYSTEM (G4FC) (1)

SD313-1

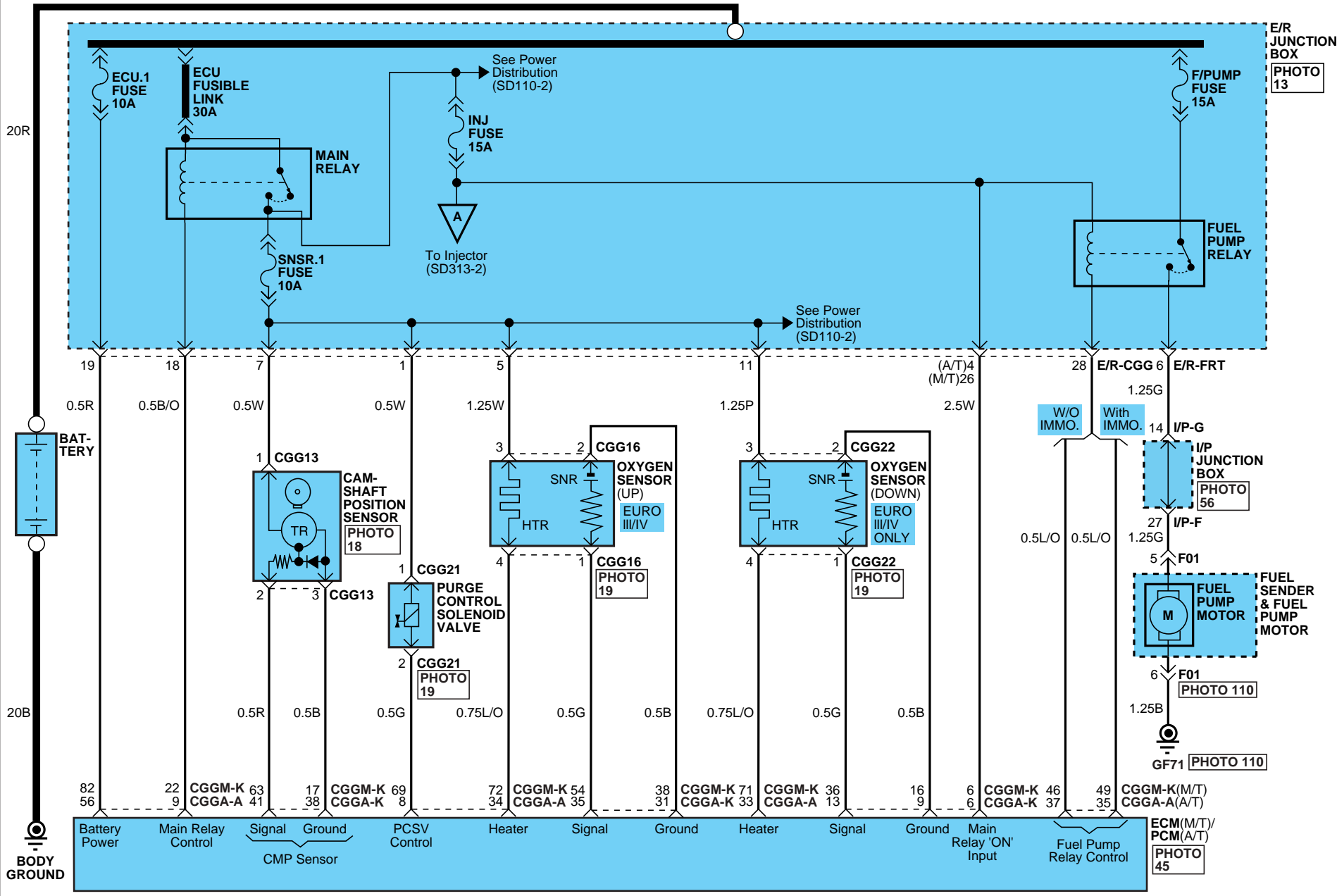

MFI CONTROL SYSTEM

MFI CONTROL SYSTEM (G4FC) (2)

SD313-2

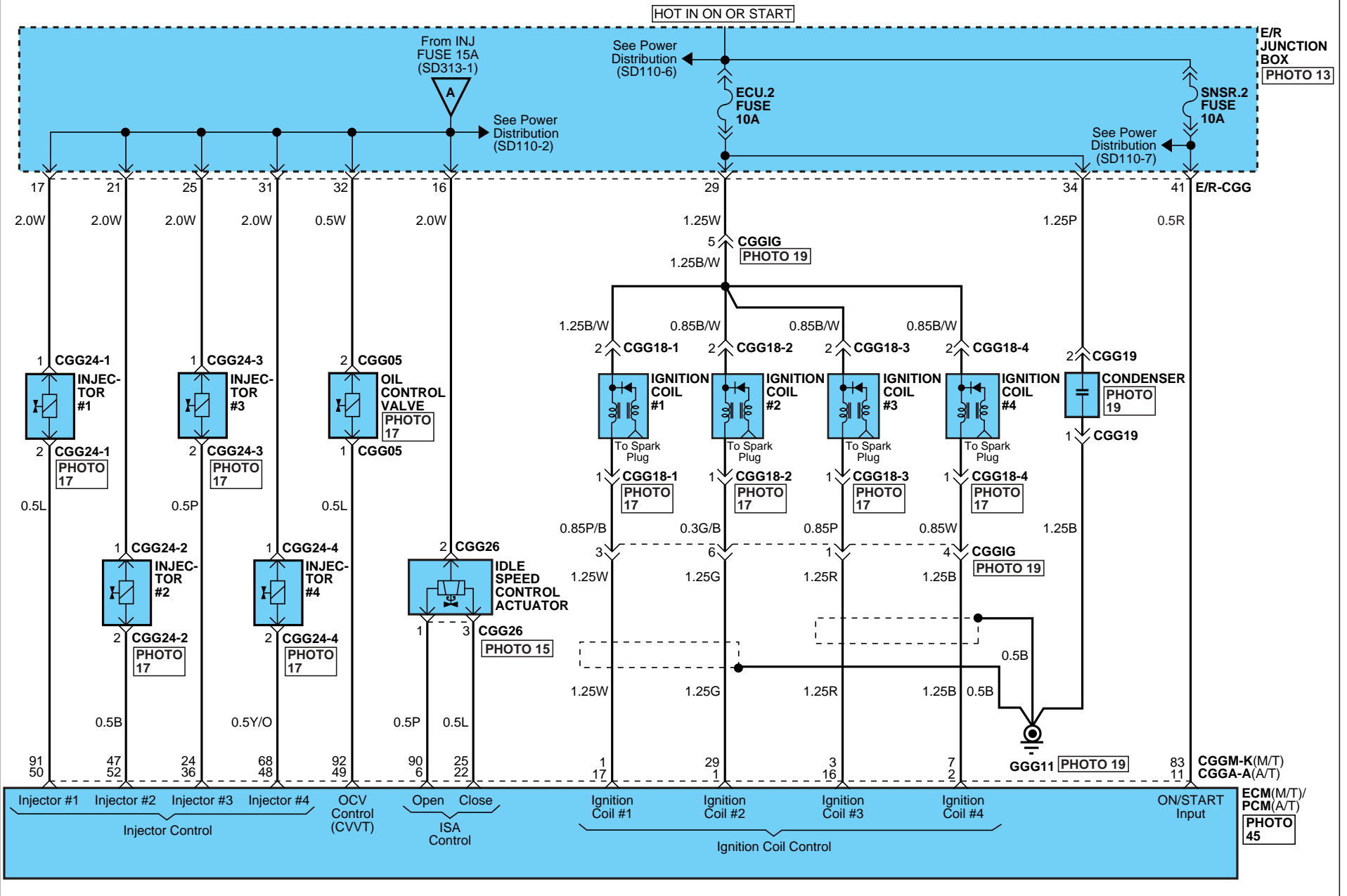

MFI CONTROL SYSTEM

MFI CONTROL SYSTEM (G4FC) (3)

SD313-3

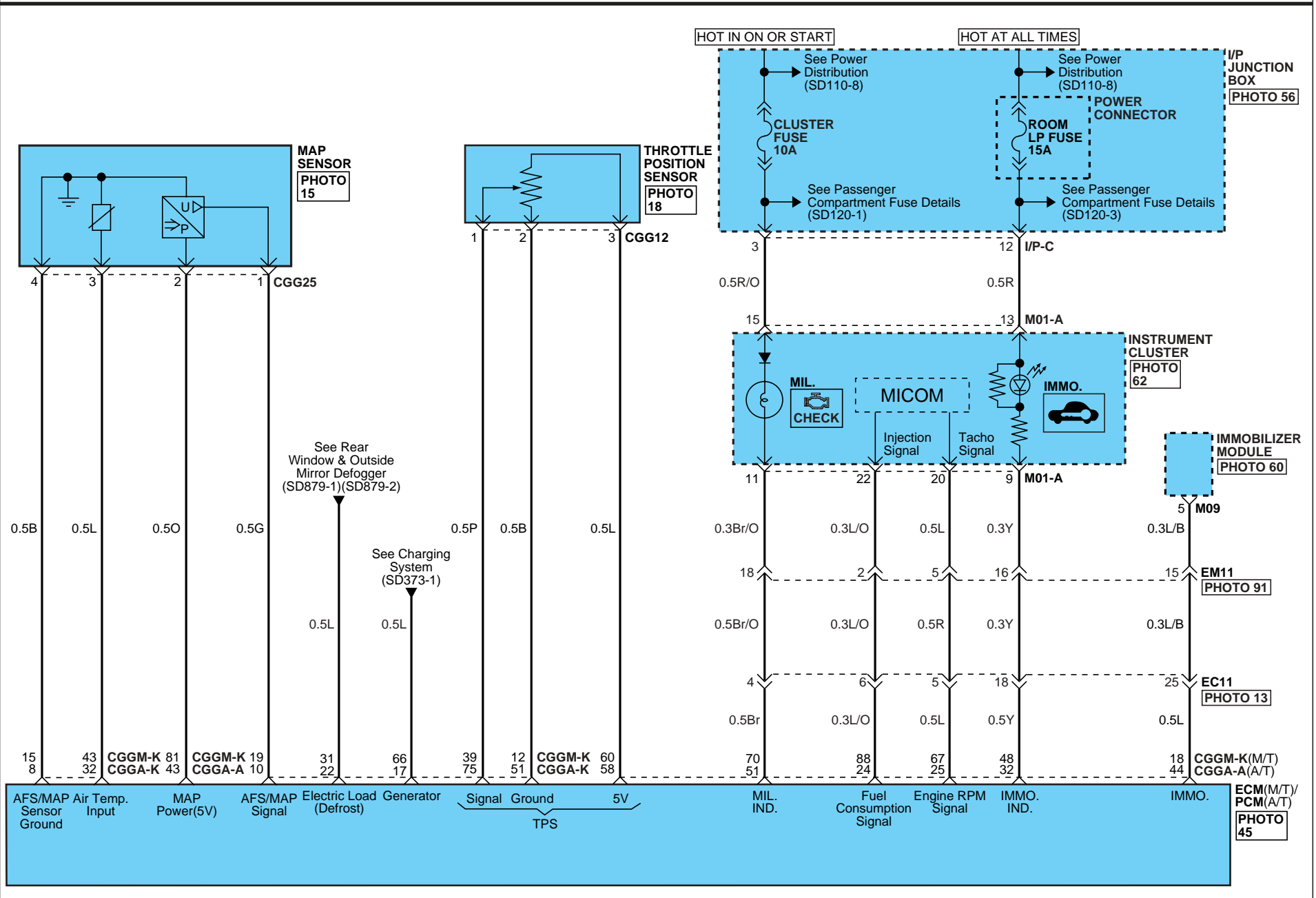

MFI CONTROL SYSTEM

MFI CONTROL SYSTEM (G4FC) (4)

SD313-4

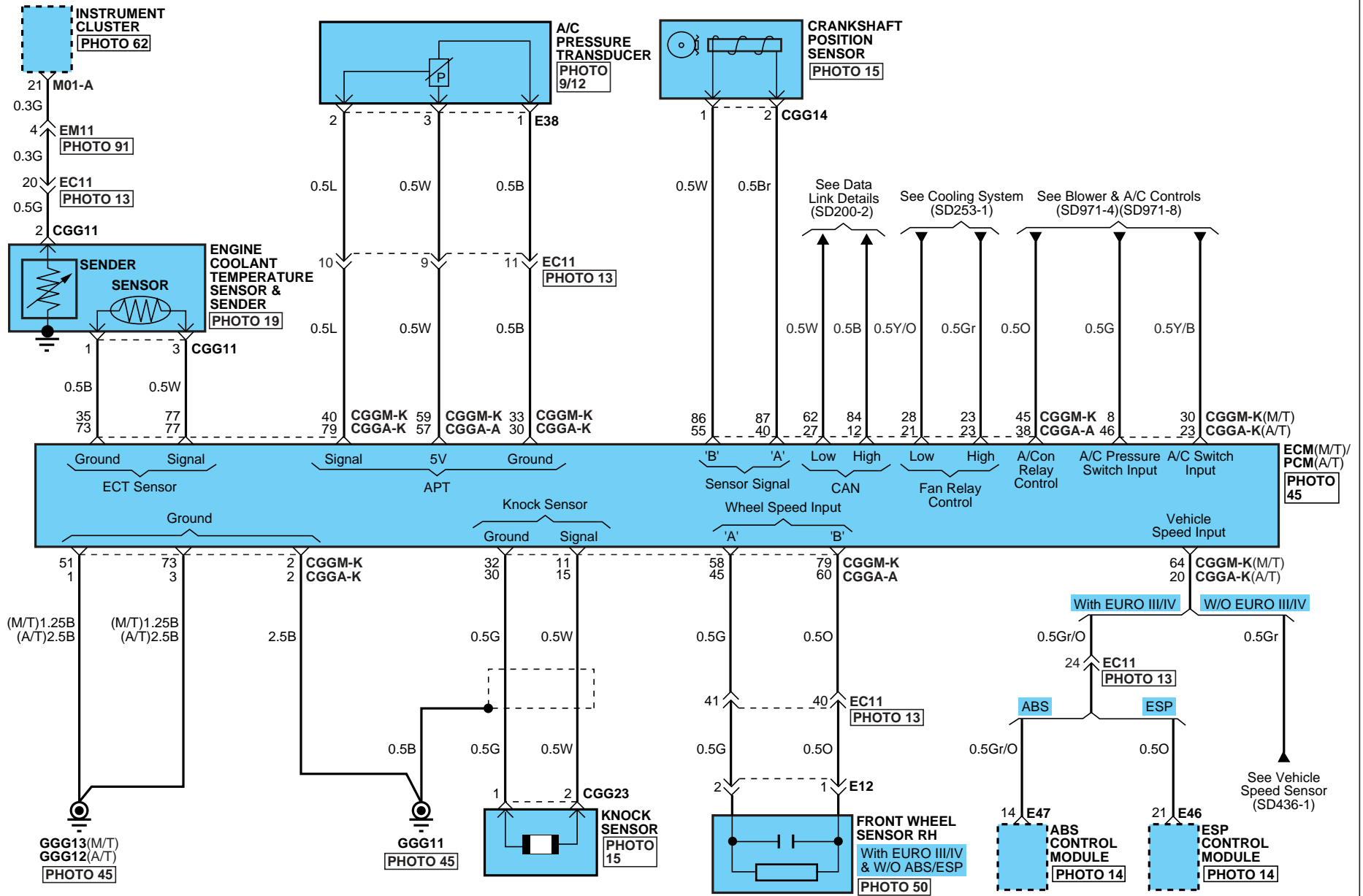

MFI CONTROL SYSTEM

MFI CONTROL SYSTEM (G4FC) (5)

SD313-5

CGGA-A

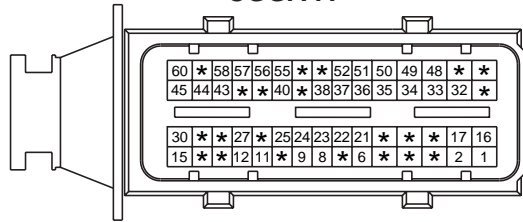

AMP_ECU_60F_B

CGGA-K

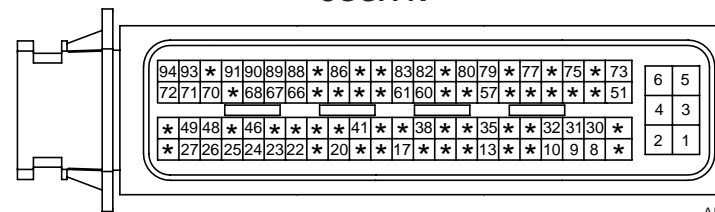

AMP_ECU_94F_B

CGGM-K

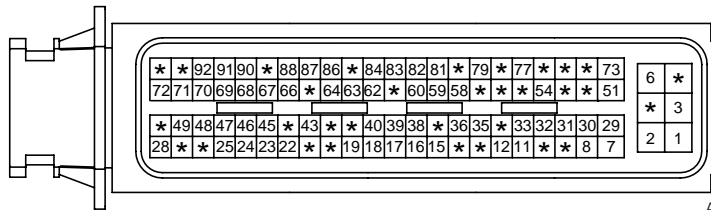

AMP_ECU_94F_B

CGG05

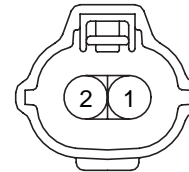

KET_090WP_02F_B_L

CGG11

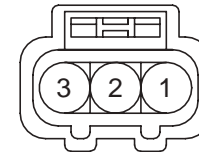

KUM_62Z_03F_B_WTS

CGG12

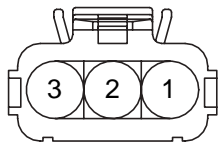

AMP_JPT_03F_B_BOSCH

CGG13

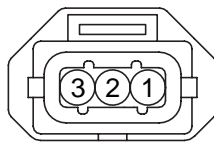

AMP_JPT_03F_B_BSH3

CGG14

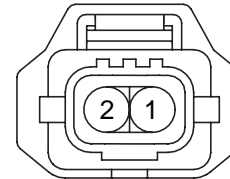

AMP_JPT_02F_B_BSH2

CGG16

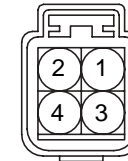

KUM_NMWP_04F_B

CGG18-1

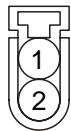

MLX_090WP_2F

CGG18-2

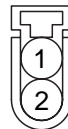

MLX_090WP_2F

CGG18-3

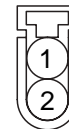

MLX_090WP_2F

CGG18-4

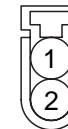

MLX_090WP_2F

CGG19



MLX_090CIGAR_02F_B

CGG21

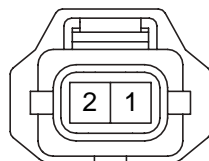

AMP_2.8WP_02F_B

CGG22



KUM_KNMWP_04F_GR

CGG23

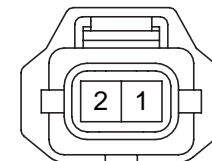



AMP_2.8WP_02F_B

MFI CONTROL SYSTEM

MFI CONTROL SYSTEM (G4FC) (6)

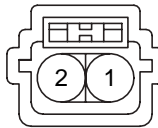
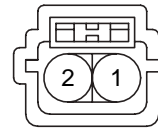
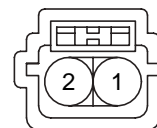
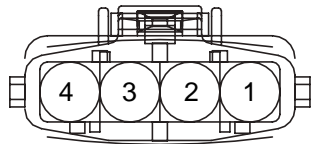
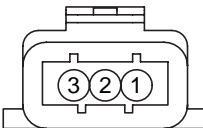
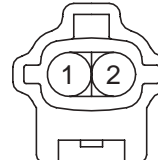
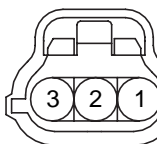
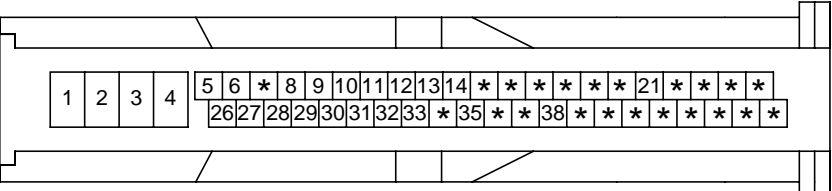
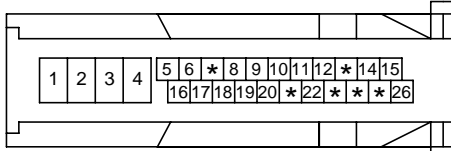
SD313-6

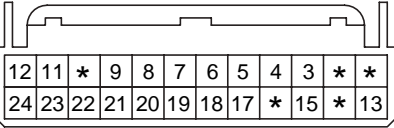
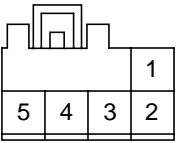
<p align="center">CGG24-1</p>  <p align="center">KUM_NDWP_02F_Gr</p>	<p align="center">CGG24-2</p>  <p align="center">KUM_NDWP_02F_Gr</p>	<p align="center">CGG24-3</p>  <p align="center">KUM_NDWP_02F_Gr</p>	<p align="center">CGG24-4</p>  <p align="center">KUM_NDWP_02F_Gr</p>
<p align="center">CGG25</p>  <p align="center">AMP_JPT_04F_B_BOSCH</p>	<p align="center">CGG26</p>  <p align="center">AMP_ISA_03F_B</p>	<p align="center">E12</p>  <p align="center">KET_090IWP_02M_Gr</p>	<p align="center">E38</p>  <p align="center">YAZ_040WP_03F_B</p>
<p align="center">E46</p>  <p align="center">BOS_ESP_46F_B_L</p>		<p align="center">E47</p>  <p align="center">BOS_ABS_26F_B_L</p>	<p align="center">F01</p>  <p align="center">KET_090IWP_06F_B</p>
<p align="center">M01-A</p>  <p align="center">AMP_025_24F_W</p>	<p align="center">M09</p>  <p align="center">KUM_CDR_05F_W</p>	<p align="center">BLANK</p>	<p align="center">BLANK</p>
Empty row			

MFI CONTROL SYSTEM (G4GC) (1)

SD313-7

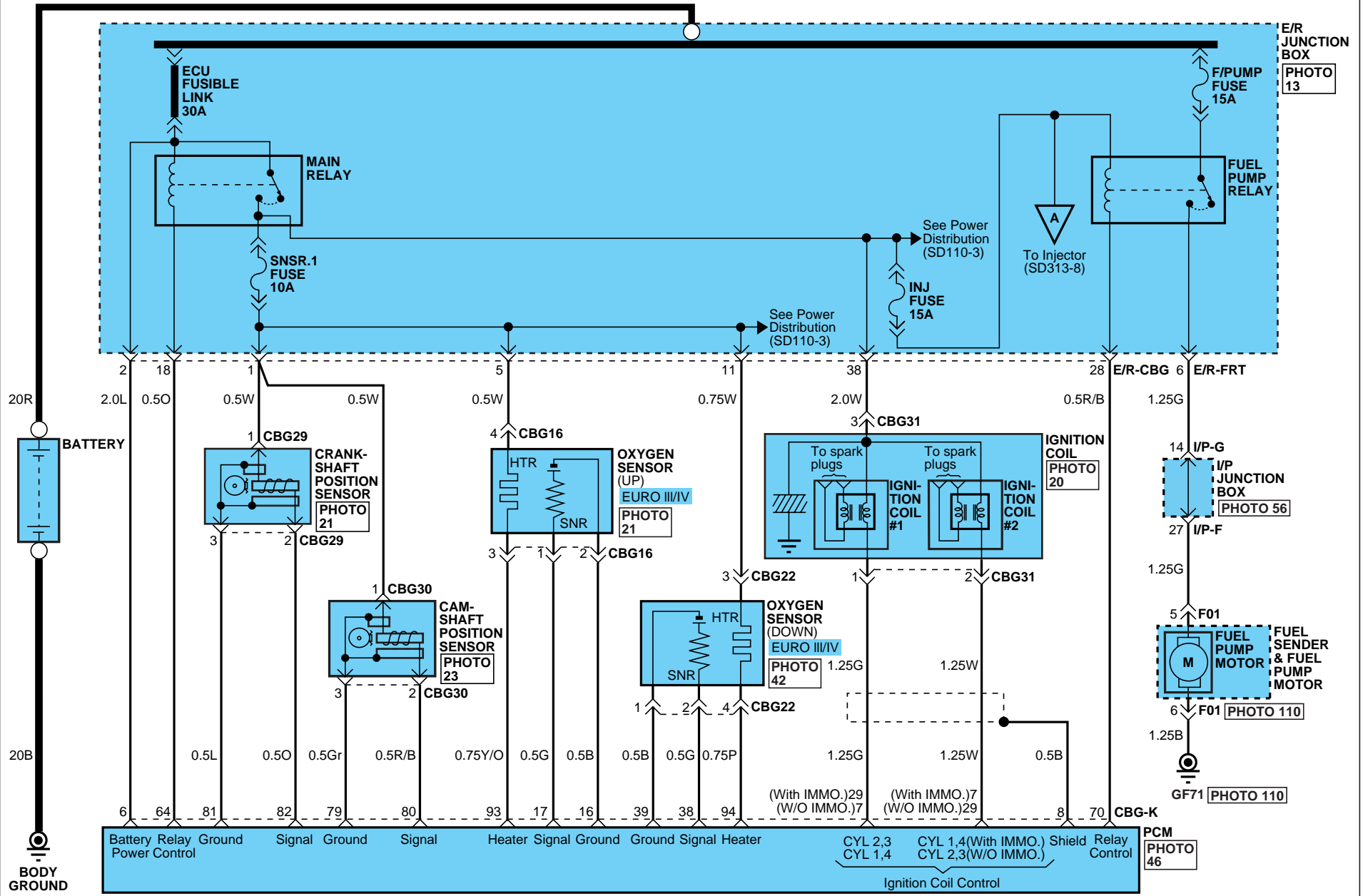

MFI CONTROL SYSTEM

MFI CONTROL SYSTEM (G4GC) (2)

SD313-8

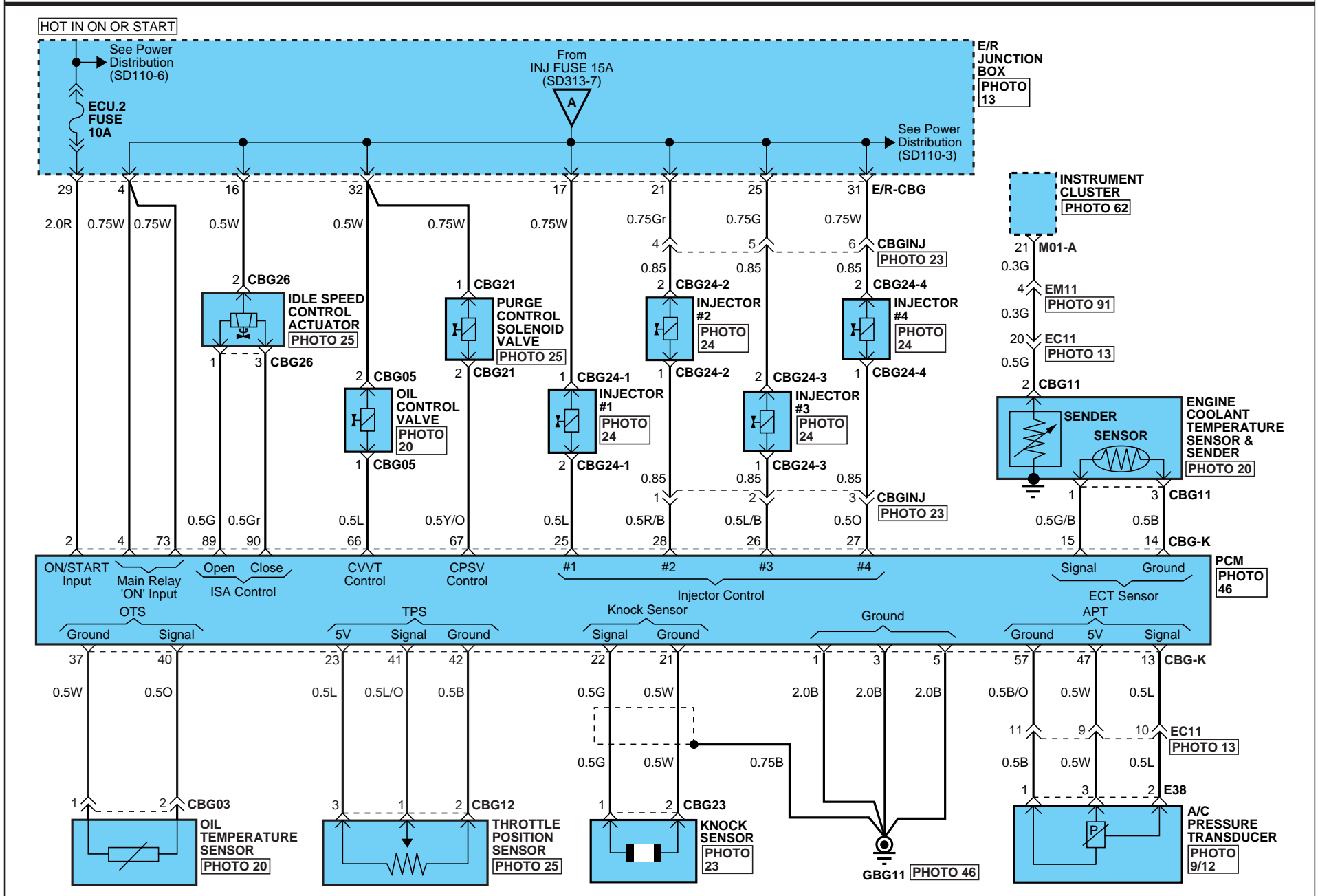

MFI CONTROL SYSTEM

MFI CONTROL SYSTEM (G4GC) (3)



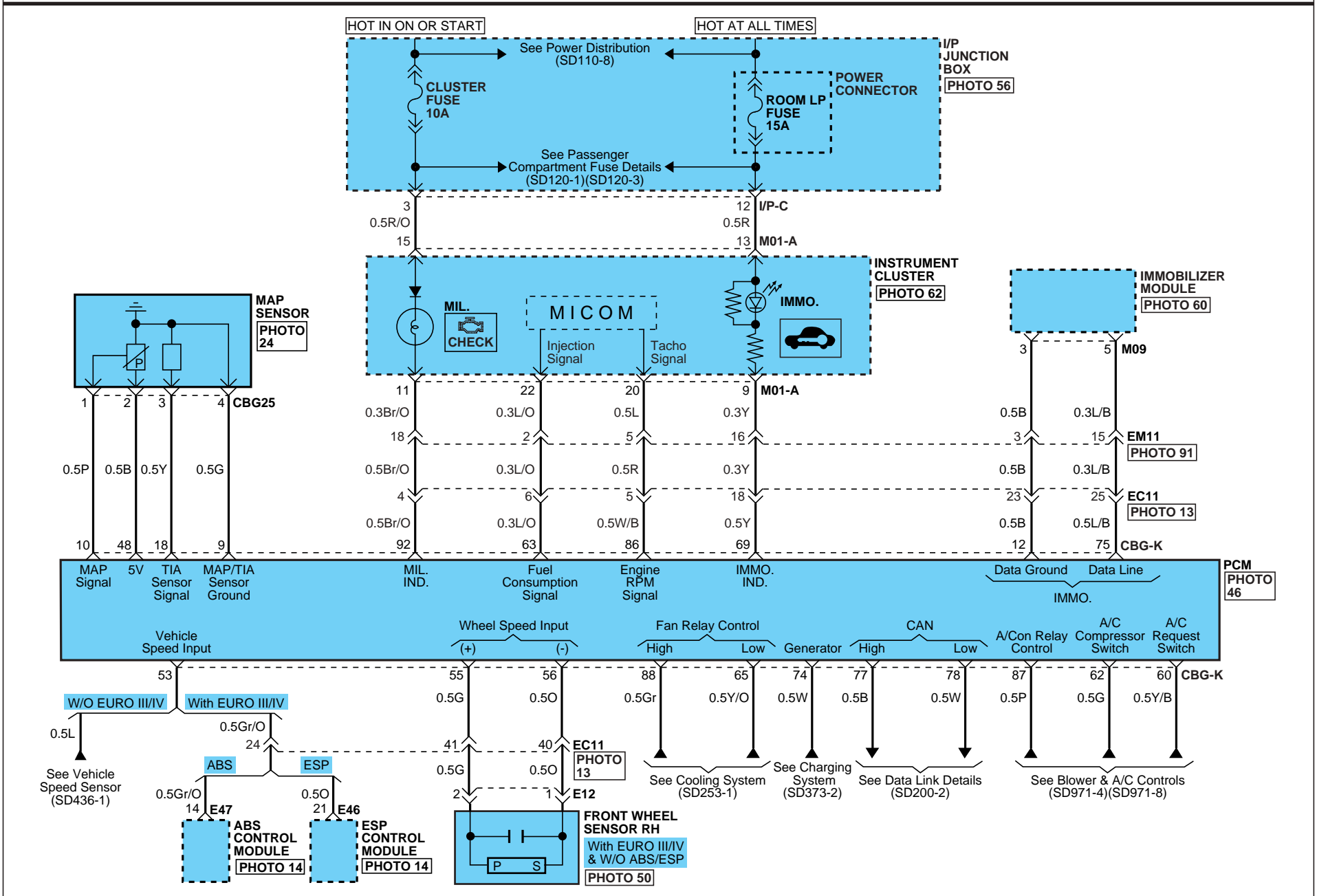



SD313-9

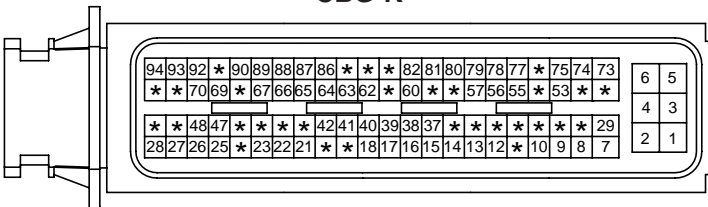
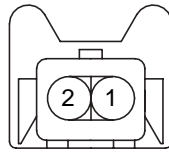

MFI CONTROL SYSTEM

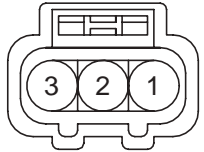
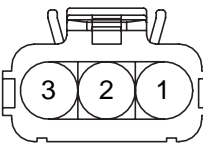
MFI CONTROL SYSTEM (G4GC) (4)

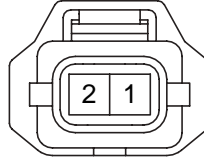
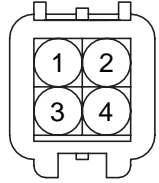
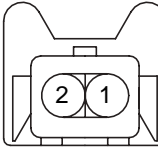
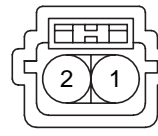
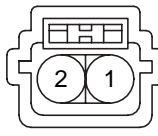
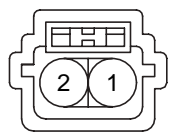
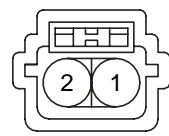
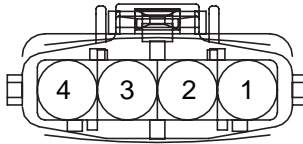
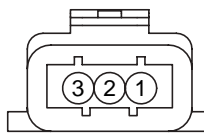
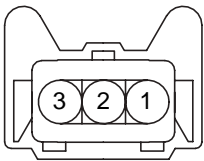
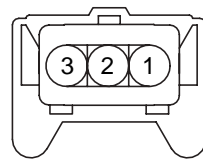
SD313-10

<p style="text-align: center;">CBG-K</p>  <p style="text-align: right;">AMP_ECU_94F_B</p>	<p style="text-align: center;">CBG03</p>  <p style="text-align: right;">AMP_JPT_02F_B</p>	<p style="text-align: center;">CBG05</p>  <p style="text-align: right;">KET_090WP_02F_B_L</p>	
<p style="text-align: center;">CBG11</p>  <p style="text-align: right;">KUM_62Z_03F_B_WTS</p>	<p style="text-align: center;">CBG12</p>  <p style="text-align: right;">AMP_JPT_03F_B_BOSCH</p>	<p style="text-align: center;">CBG16</p>  <p style="text-align: right;">AMP_EJWP_04F_B</p>	<p style="text-align: center;">CBG21</p>  <p style="text-align: right;">AMP_2.8WP_02F_B</p>
<p style="text-align: center;">CBG22</p>  <p style="text-align: right;">KUM_NMWP_04M_B</p>	<p style="text-align: center;">CBG23</p>  <p style="text-align: right;">AMP_JPT_02F_B</p>	<p style="text-align: center;">CBG24-1</p>  <p style="text-align: right;">KUM_NDWP_02F_Gr</p>	<p style="text-align: center;">CBG24-2</p>  <p style="text-align: right;">KUM_NDWP_02F_Gr</p>
<p style="text-align: center;">CBG24-3</p>  <p style="text-align: right;">KUM_NDWP_02F_Gr</p>	<p style="text-align: center;">CBG24-4</p>  <p style="text-align: right;">KUM_NDWP_02F_Gr</p>	<p style="text-align: center;">CBG25</p>  <p style="text-align: right;">AMP_JPT_04F_B_BOSCH</p>	<p style="text-align: center;">CBG26</p>  <p style="text-align: right;">AMP_ISA_03F_B</p>
<p style="text-align: center;">CBG29</p>  <p style="text-align: right;">AMP_JPT_03F_Gr_R1</p>	<p style="text-align: center;">CBG30</p>  <p style="text-align: right;">AMP_JPT_03F_B_S1</p>	<p style="text-align: center;">CBG31</p>  <p style="text-align: right;">KET_090IWP_03F_B</p>	<p style="text-align: center;">E12</p>  <p style="text-align: right;">KET_090IWP_02M_Gr</p>

MFI CONTROL SYSTEM

MFI CONTROL SYSTEM (G4GC) (5)

SD313-11

E38

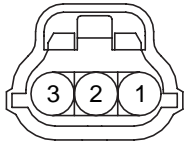

YAZ_040WP_03F_B

E46

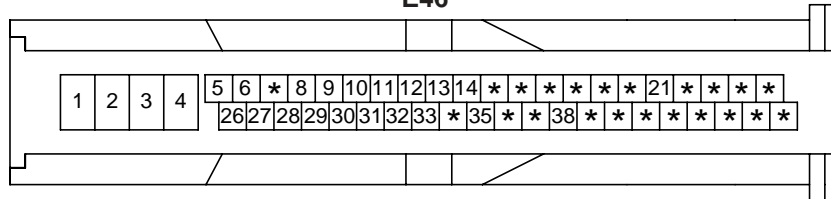

BOS_ESP_46F_B_L

E47

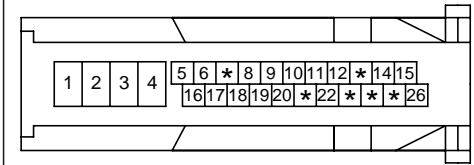

BOS_ABS_26F_B_L

F01



KET_090IWP_06F_B

M01-A

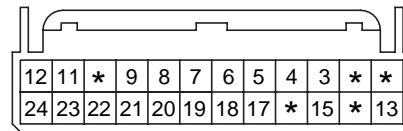

AMP_025_24F_W

M09

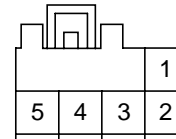

KUM_CDR_05F_W

BLANK

MFI CONTROL SYSTEM

MFI CONTROL SYSTEM (G4GC) (6)

SD313-12

MEMO

MFI CONTROL SYSTEM (D4FB) (1)

SD313-13

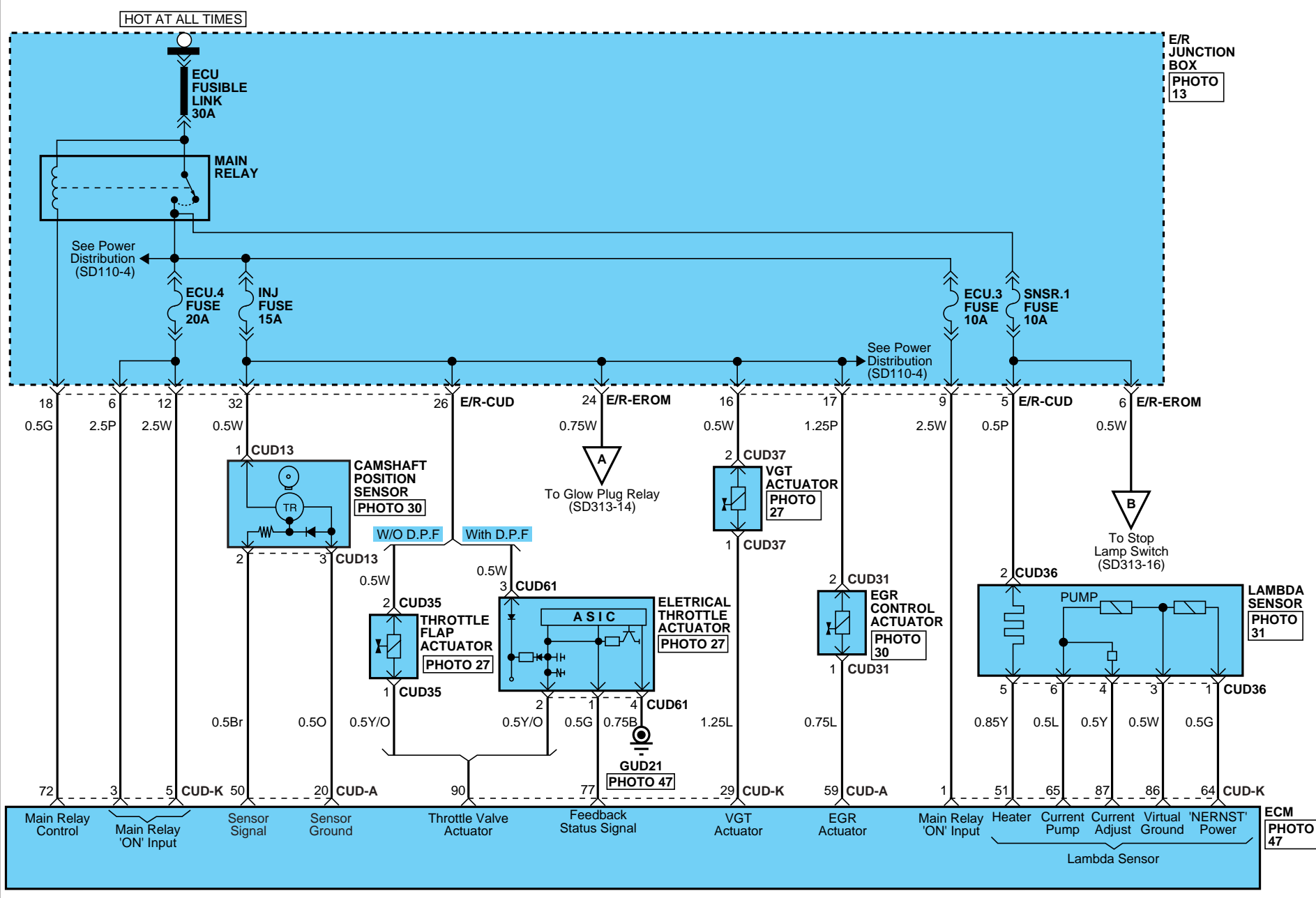

MFI CONTROL SYSTEM

MFI CONTROL SYSTEM (D4FB) (2)

SD313-14

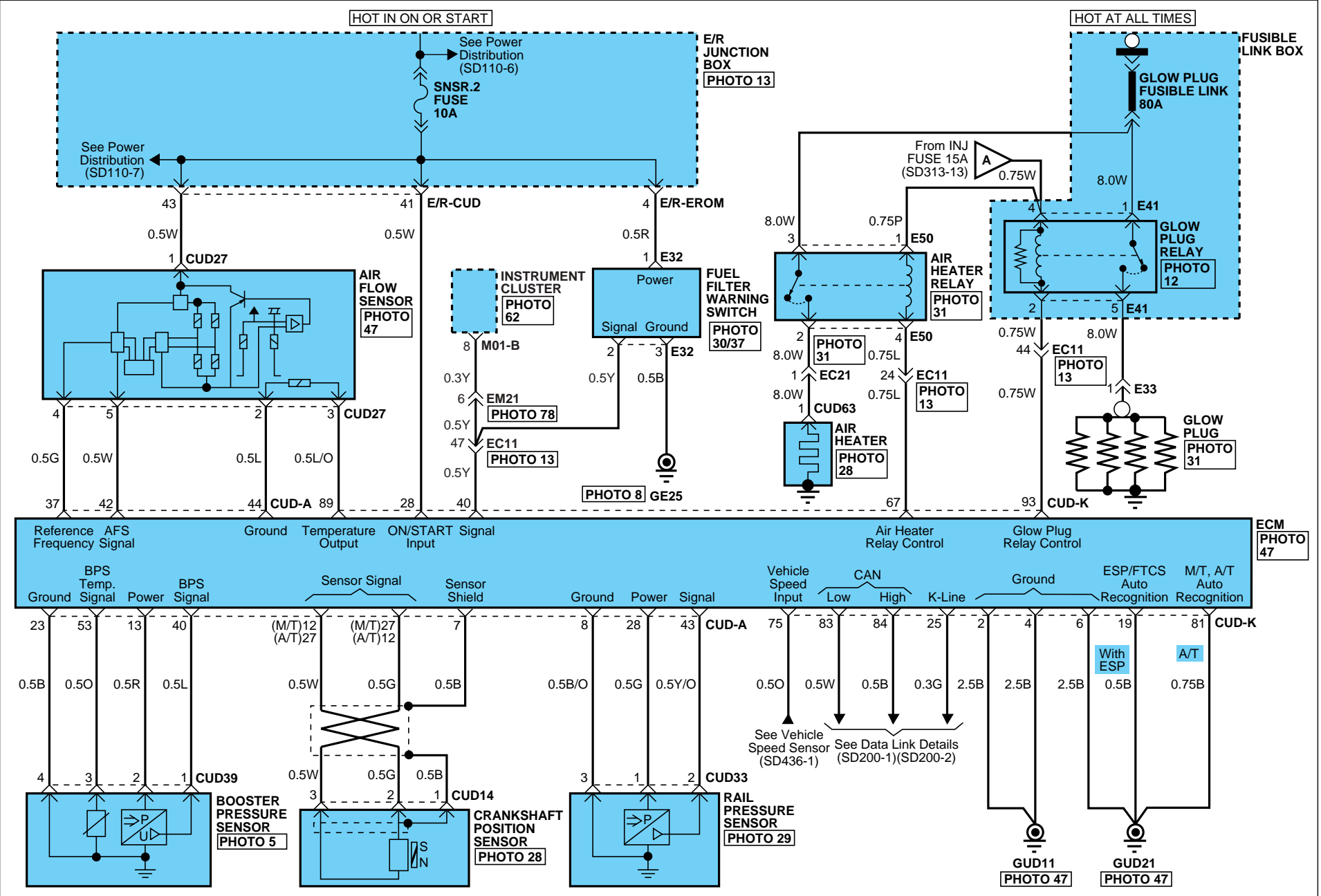

MFI CONTROL SYSTEM

MFI CONTROL SYSTEM (D4FB) (3)

SD313-15

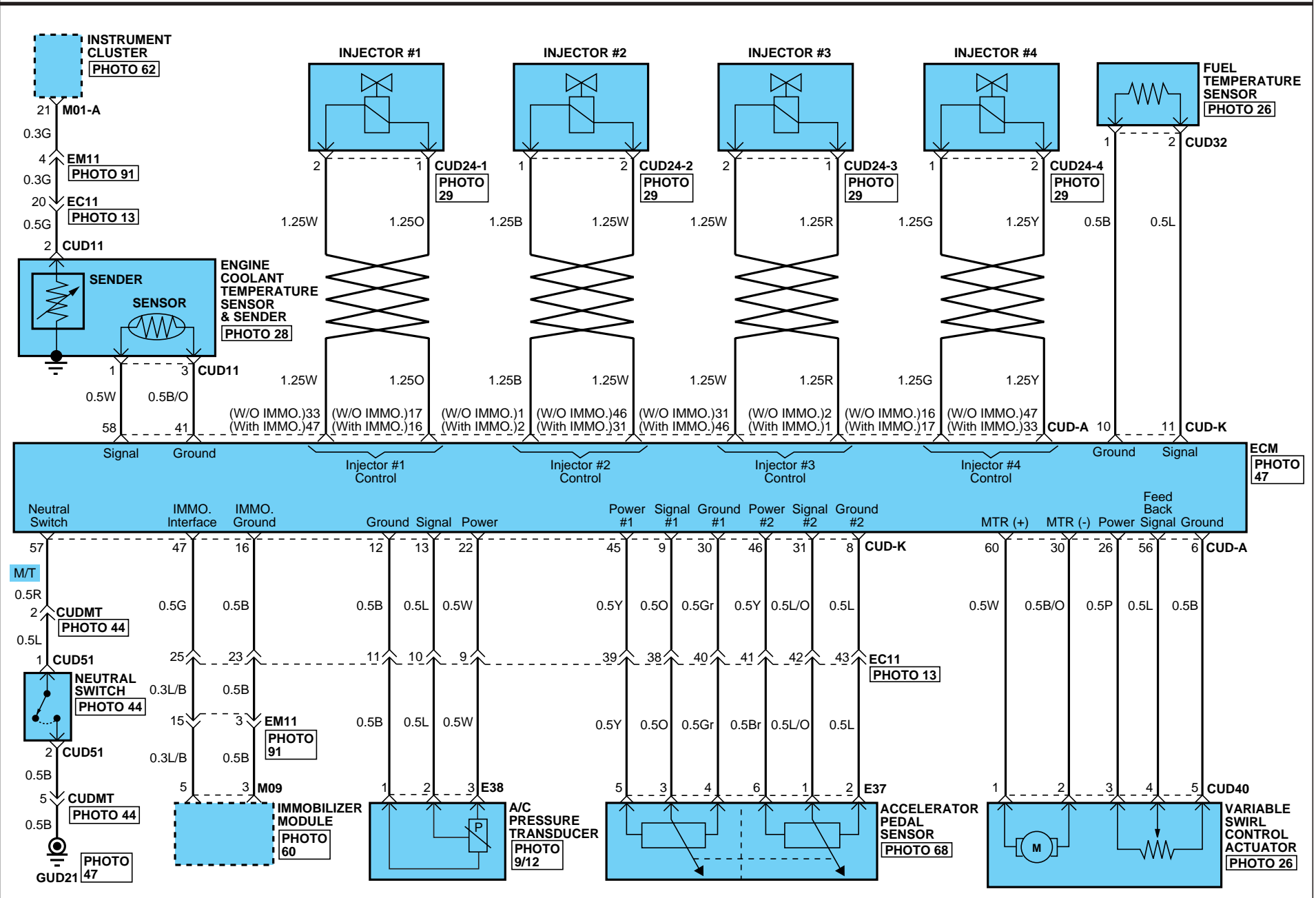

MFI CONTROL SYSTEM

MFI CONTROL SYSTEM (D4FB) (4)

SD313-16

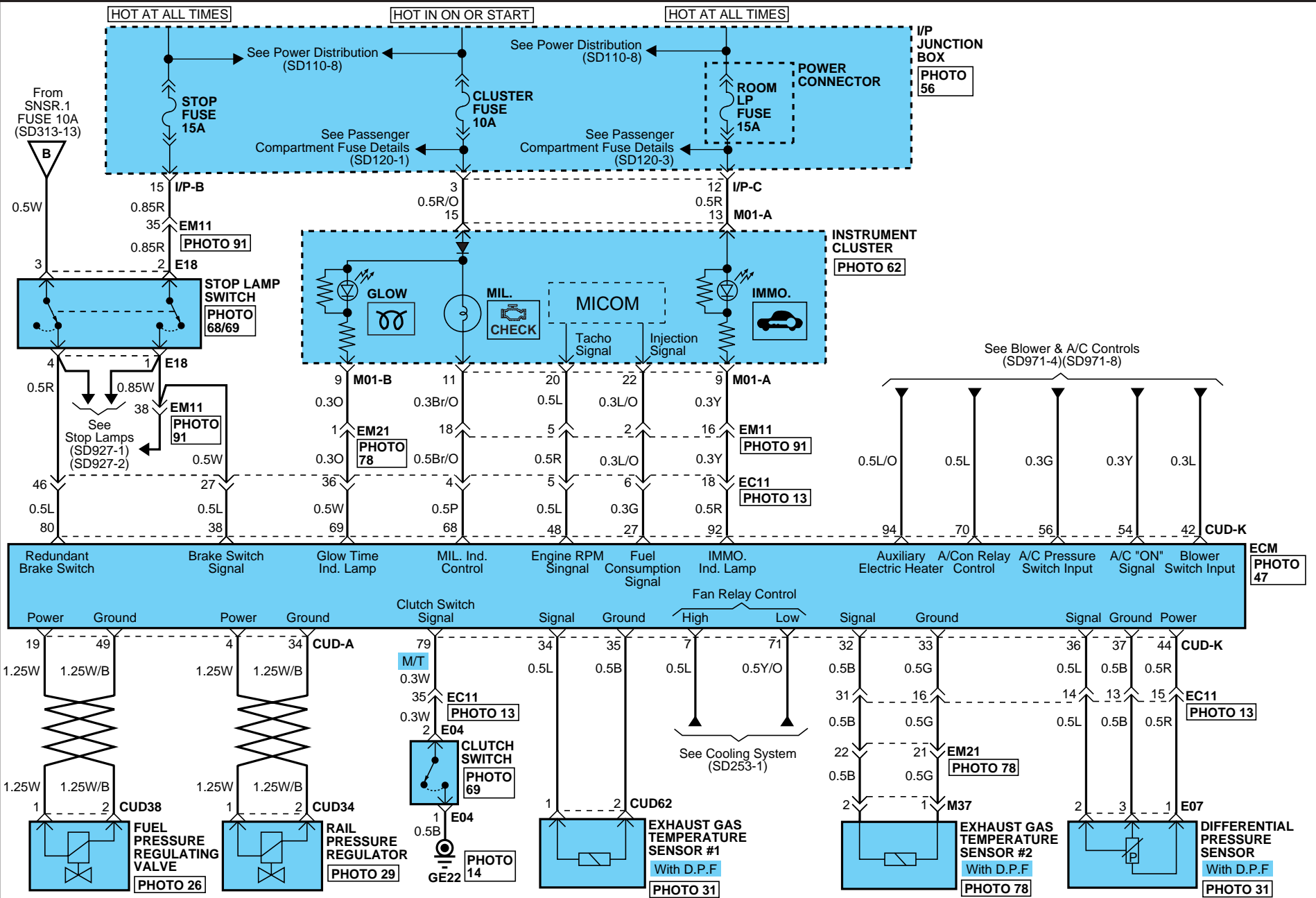

MFI CONTROL SYSTEM

MFI CONTROL SYSTEM (D4FB) (5)

SD313-17

CUD-A

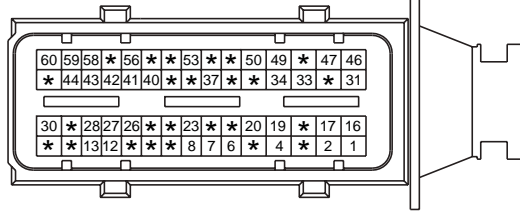

AMP_ECU_60F_B

CUD-K

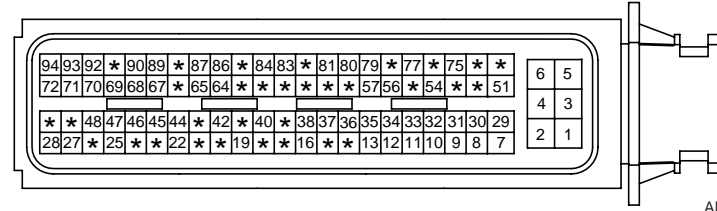

AMP_ECU_94F_B

CUD11

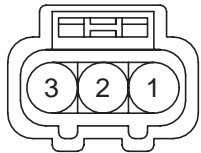

KUM_62Z_03F_B_WTS

CUD13

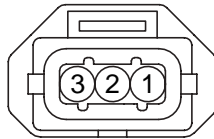

AMP_SFT_03F_B_1

CUD14

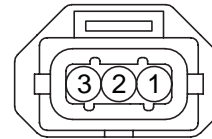

AMP_SFT_03F_B_1

CUD24-1/-2/-3/-4

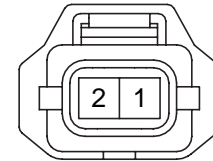

AMP_2.8WP_02F_B

CUD27

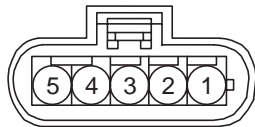

HSM_SENSOR_05F_B

CUD31

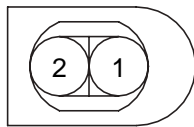

KST_SENSOR_02F_B_NF

CUD32

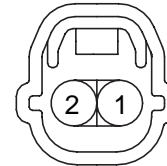

KET_SSD_02F_B

CUD33

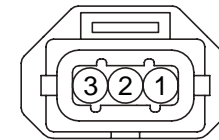

AMP_JPT_03F_B_L1

CUD34

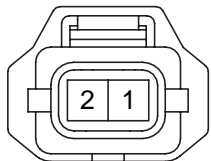

AMP_2.8WP_02F_B

CUD35

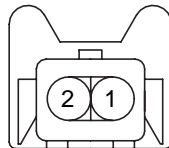

AMP_JPT_02F_Gr

CUD36

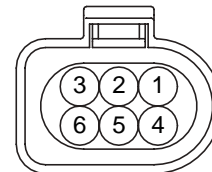

BSH_SENSOR_06F_B_NF

CUD37

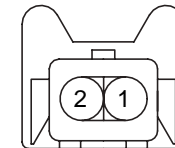

AMP_JPT_02F_B

CUD38

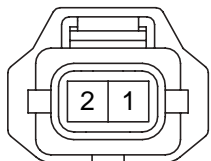

AMP_2.8WP_02F_B

CUD39

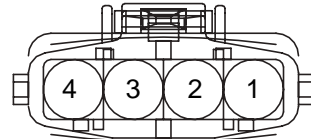

AMP_JPT_04F_B_BOSCH

CUD40

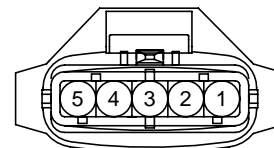

AMP_JPT_05F_B_SFT

CUD51







AMP_090WP_02F_B

MFI CONTROL SYSTEM

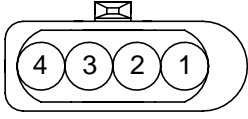
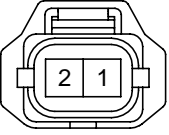
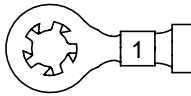
MFI CONTROL SYSTEM (D4FB) (6)

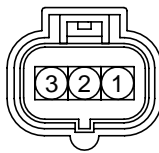
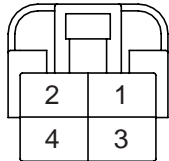
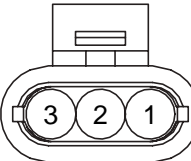
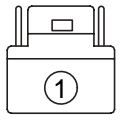
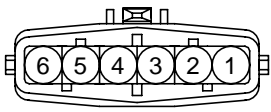
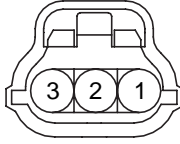
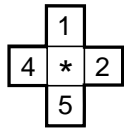
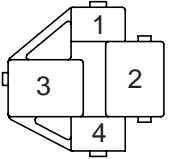
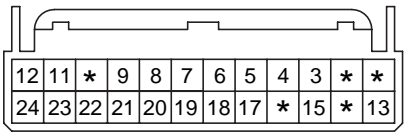
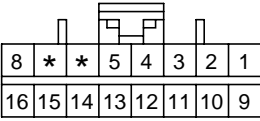
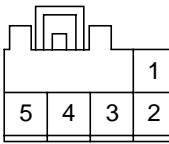
SD313-18

<p style="text-align: center;">CUD61</p>  <p style="text-align: center;">FEP_NFDSL_04F_N</p>	<p style="text-align: center;">CUD62</p>  <p style="text-align: center;">AMP_2.8WP_02F_B</p>	<p style="text-align: center;">CUD63</p>  <p style="text-align: center;">KET_EARTH_6.4_01F</p>	<p style="text-align: center;">E04</p>  <p style="text-align: center;">KET_250DL_02F_W</p>
<p style="text-align: center;">E07</p>  <p style="text-align: center;">SUM_090IWP_03F_B</p>	<p style="text-align: center;">E18</p>  <p style="text-align: center;">KET_250DL_04F_W</p>	<p style="text-align: center;">E32</p>  <p style="text-align: center;">AMP_1.5WP_03F_B</p>	<p style="text-align: center;">E33</p>  <p style="text-align: center;">YAZ_375WP_01F_B</p>
<p style="text-align: center;">E37</p>  <p style="text-align: center;">BSH_JPT_06F_B</p>	<p style="text-align: center;">E38</p>  <p style="text-align: center;">YAZ_040WP_03F_B</p>	<p style="text-align: center;">E41</p>  <p style="text-align: center;">CR05F019</p>	<p style="text-align: center;">E50</p>  <p style="text-align: center;">KET_3725_04F_B</p>
<p style="text-align: center;">M01-A</p>  <p style="text-align: center;">AMP_025_24F_W</p>	<p style="text-align: center;">M01-B</p>  <p style="text-align: center;">AMP_040M2_16F_B</p>	<p style="text-align: center;">M09</p>  <p style="text-align: center;">KUM_CDR_05F_W</p>	<p style="text-align: center;">M37</p>  <p style="text-align: center;">SUM_SENSOR_02M_B</p>

MFI CONTROL SYSTEM (D4EA) (1)

SD313-19

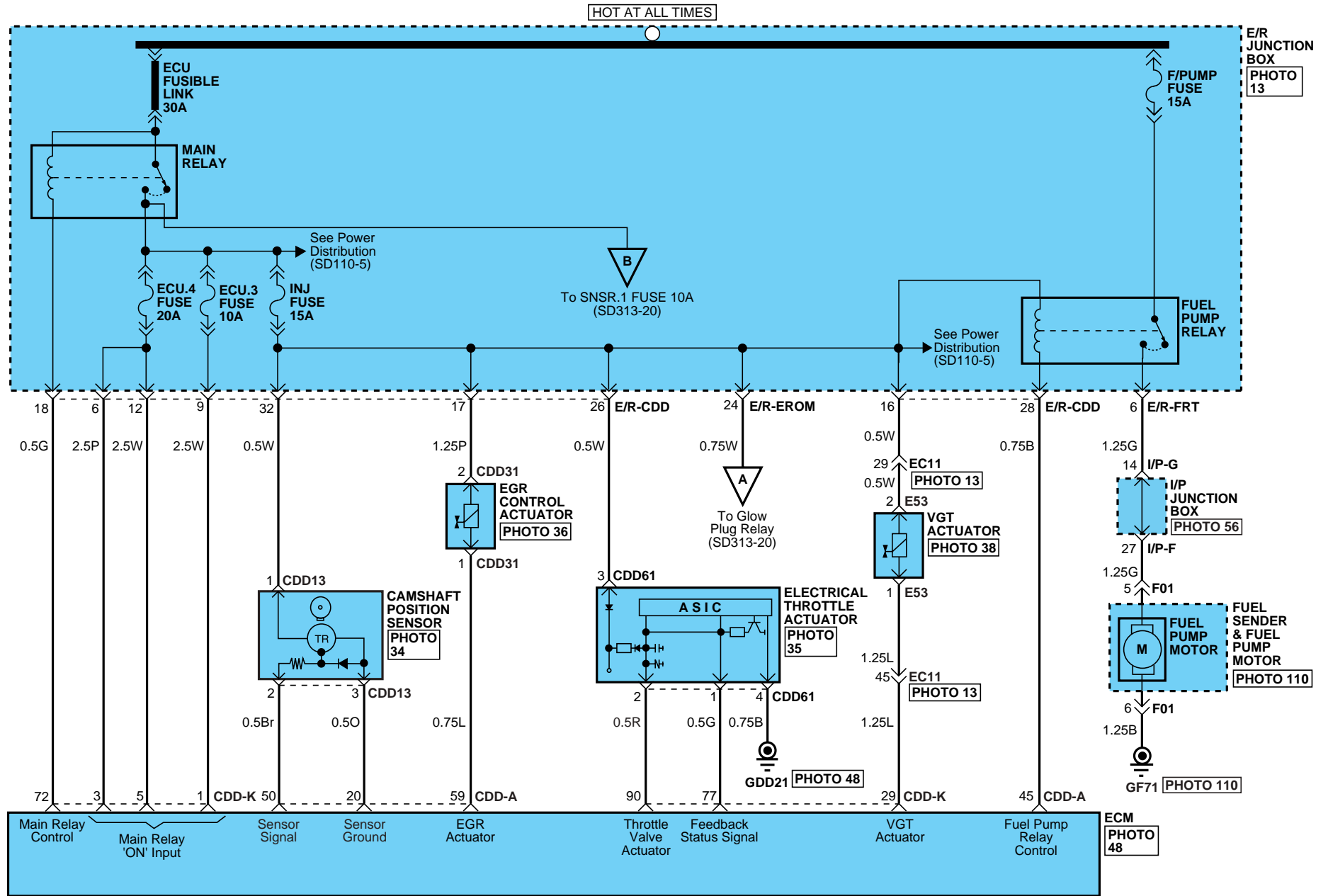

MFI CONTROL SYSTEM

MFI CONTROL SYSTEM (D4EA) (2)

SD313-20

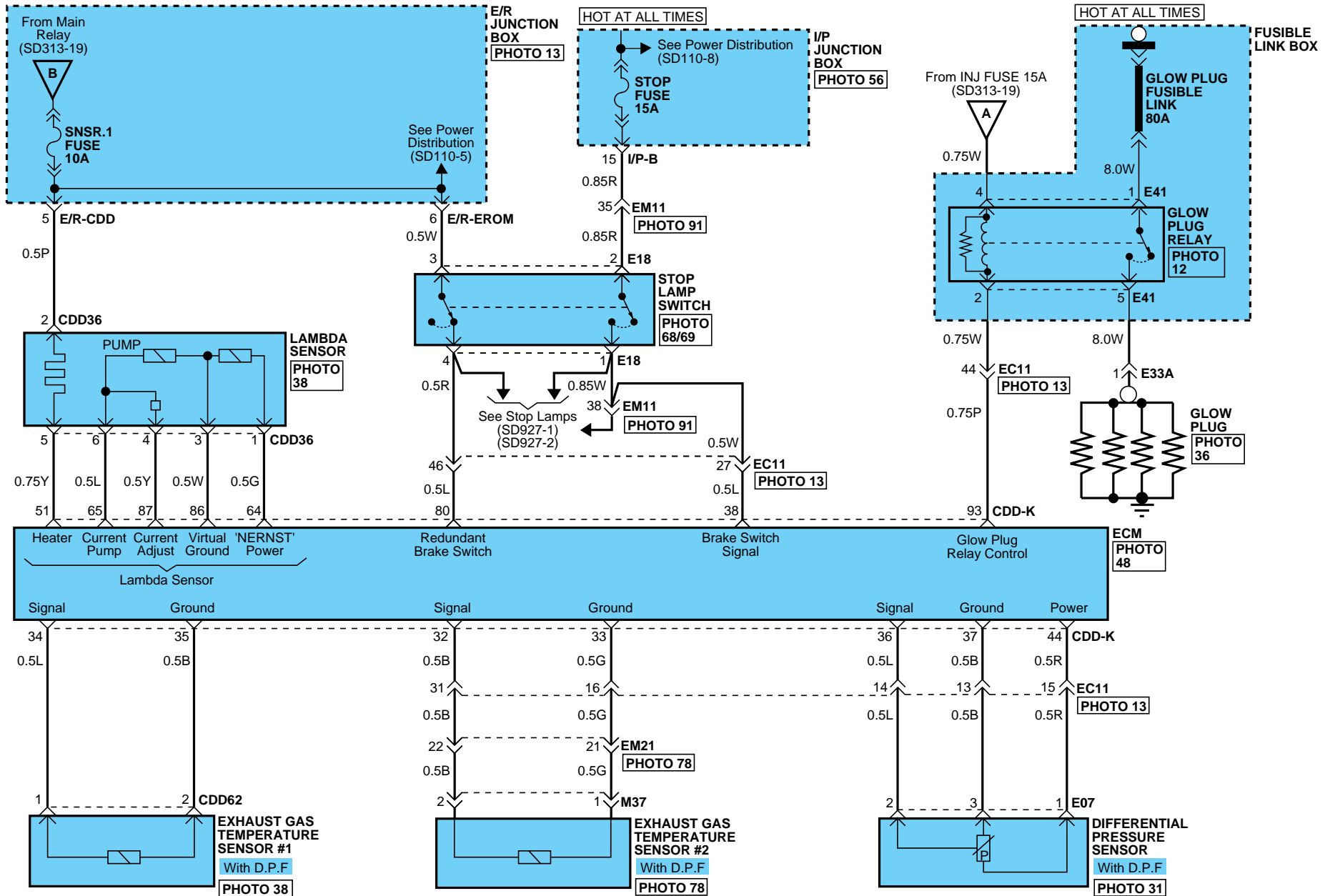

MFI CONTROL SYSTEM

MFI CONTROL SYSTEM (D4EA) (3)

SD313-21

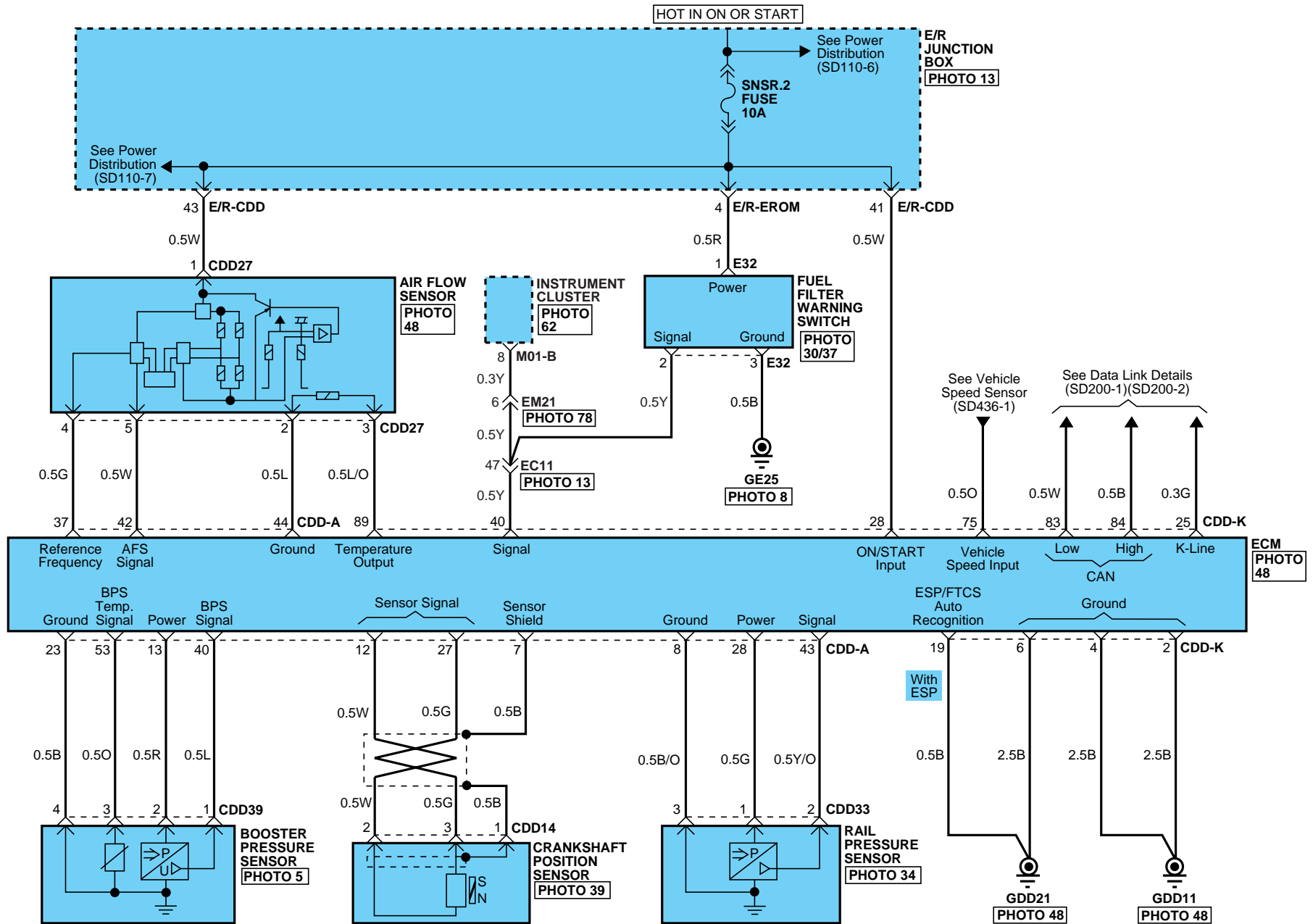

MFI CONTROL SYSTEM

MFI CONTROL SYSTEM (D4EA) (4)

SD313-22

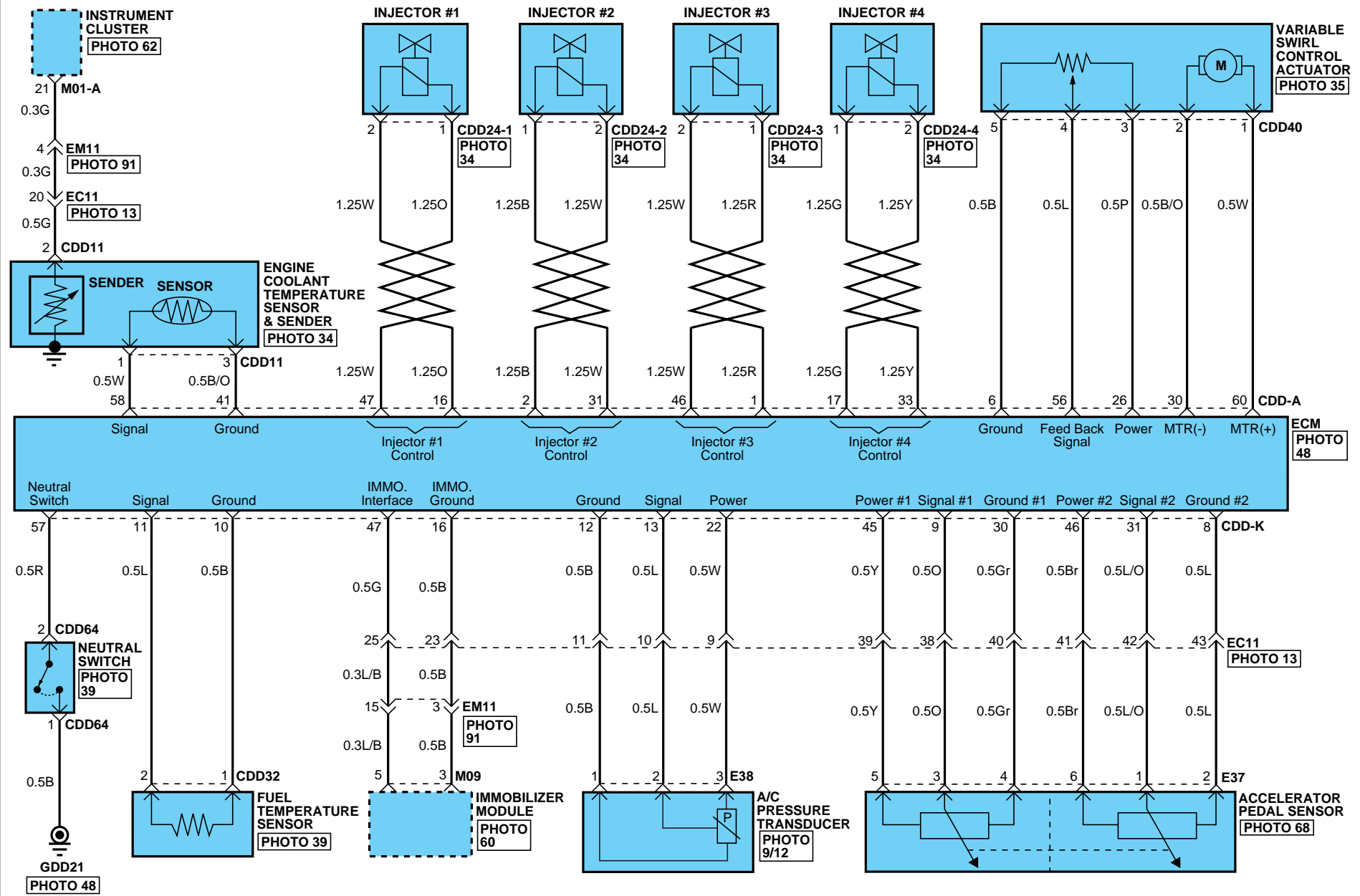

MFI CONTROL SYSTEM

MFI CONTROL SYSTEM (D4EA) (5)



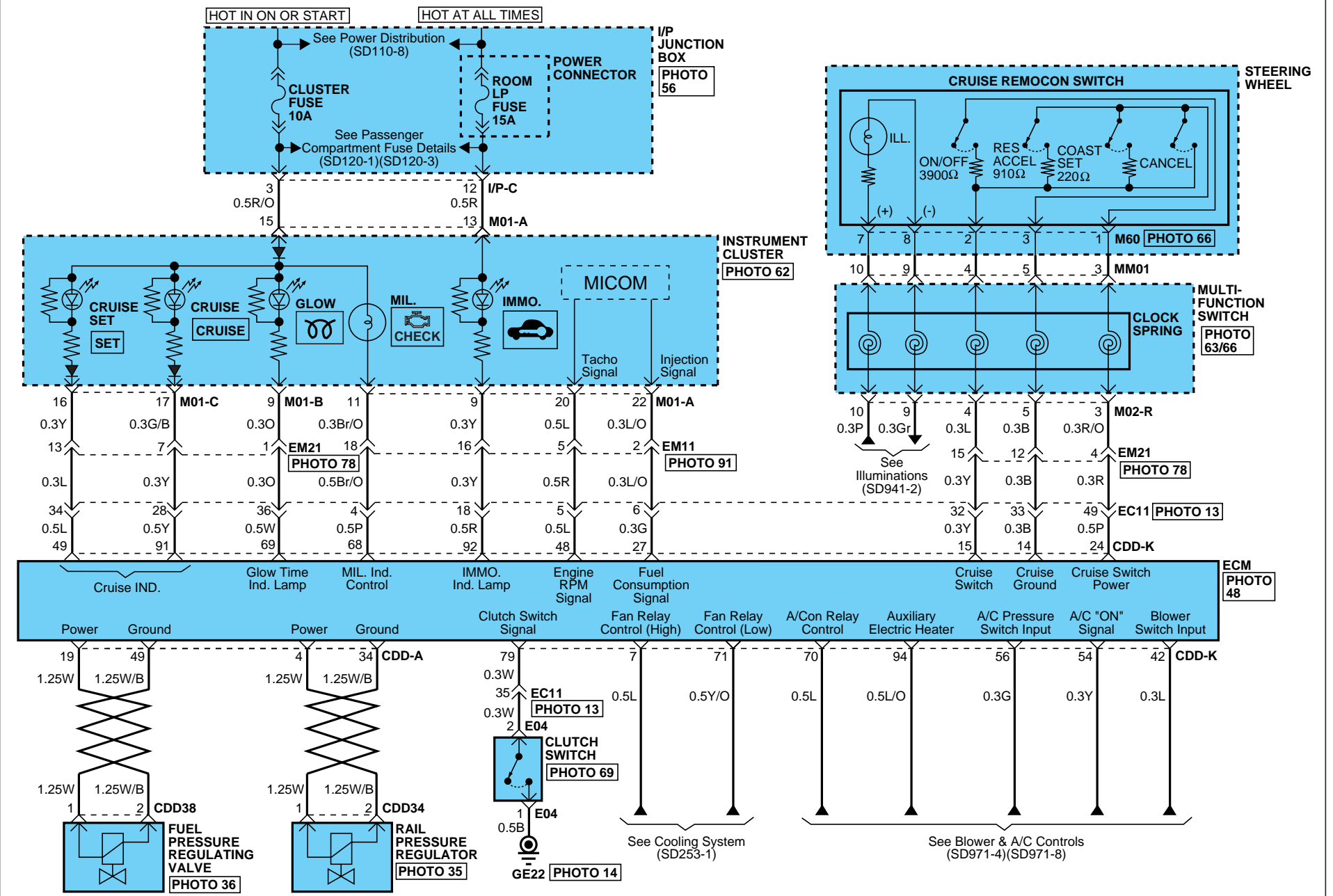

SD313-23

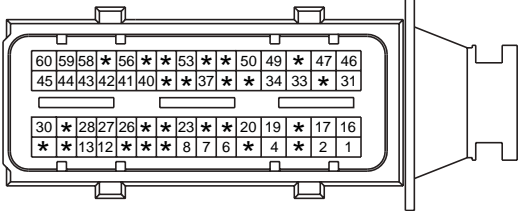
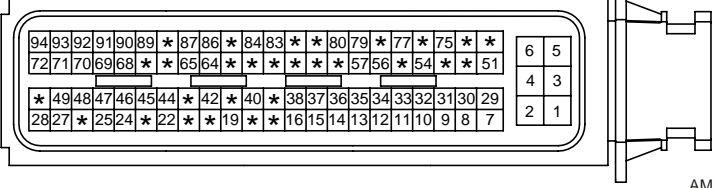
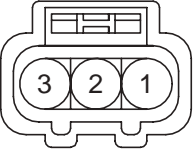

MFI CONTROL SYSTEM

MFI CONTROL SYSTEM (D4EA) (6)

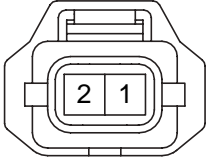
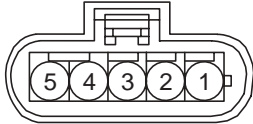
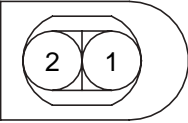
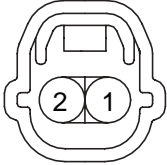
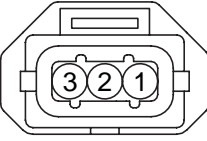
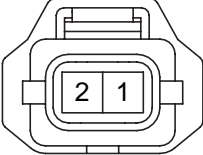
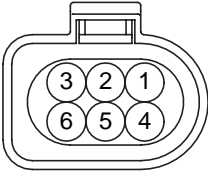
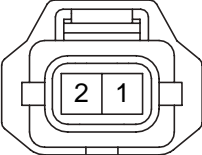
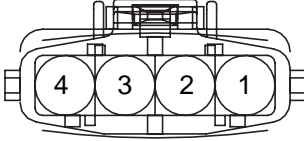
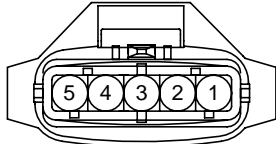
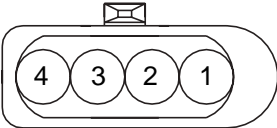
SD313-24

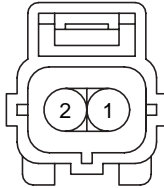
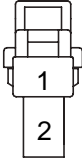
<p>CDD-A</p>  <p>AMP_ECU_60F_B</p>		<p>CDD-K</p>  <p>AMP_ECU_94F_B</p>	
<p>CDD11</p>  <p>KUM_62Z_03F_B_WTS</p>	<p>CDD13/CDD14</p>  <p>AMP_SFT_03F_B_1</p>	<p>CDD24-1/-2/-3/-4</p>  <p>AMP_2.8WP_02F_B</p>	<p>CDD27</p>  <p>HSM_SENSOR_05F_B</p>
<p>CDD31</p>  <p>KST_SENSOR_02F_B_NF</p>	<p>CDD32</p>  <p>KET_SSD_02F_B</p>	<p>CDD33</p>  <p>AMP_JPT_03F_B_L1</p>	<p>CDD34</p>  <p>AMP_2.8WP_02F_B</p>
<p>CDD36</p>  <p>BSH_SENSOR_06F_B_NF</p>	<p>CDD38</p>  <p>AMP_2.8WP_02F_B</p>	<p>CDD39</p>  <p>AMP_JPT_04F_B_BOSCH</p>	<p>CDD40</p>  <p>AMP_JPT_05F_B_SFT</p>
<p>CDD61</p>  <p>FEP_NFDSL_04F_N</p>	<p>CDD62</p>  <p>AMP_2.8WP_02F_B</p>	<p>CDD64</p>  <p>AMP_EJWP_02F_B</p>	<p>E04</p>  <p>KET_250DL_02F_W</p>

MFI CONTROL SYSTEM

MFI CONTROL SYSTEM (D4EA) (7)

SD313-25

E07

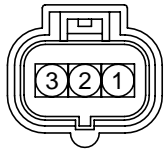

SUM_090IWP_03F_B

E18

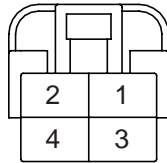

KET_250DL_04F_W

E32

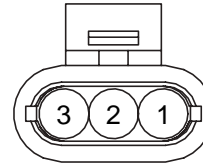

AMP_1.5WP_03F_B

E33A

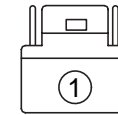

YAZ_375WP_01F_B

E37

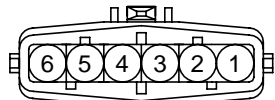

BSH_JPT_06F_B

E38

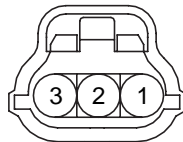

YAZ_040WP_03F_B

E41

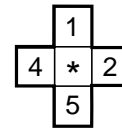

CR05F019

E53

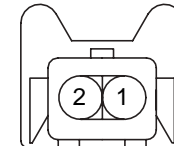

AMP_JPT_02F_B

F01



KET_090IWP_06F_B

M01-A

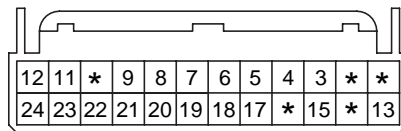

AMP_025_24F_W

M01-B

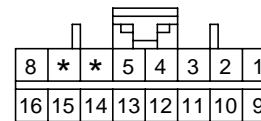

AMP_040M2_16F_B

M01-C

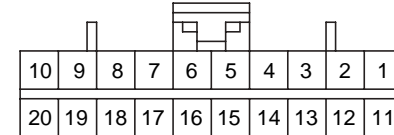

AMP_040M2_20F_B

M02-R

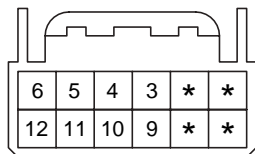

AMP_025_12F_W

M09

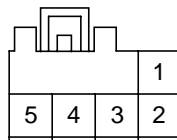

KUM_CDR_05F_W

M37

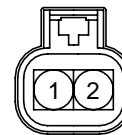

SUM_SENSOR_02M_B

M60

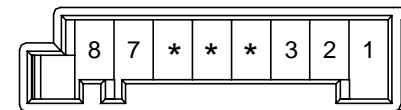

CR08F068

MFI CONTROL SYSTEM

MFI CONTROL SYSTEM (D4EA) (8)

SD313-26

MEMO

STARTING SYSTEM (1)

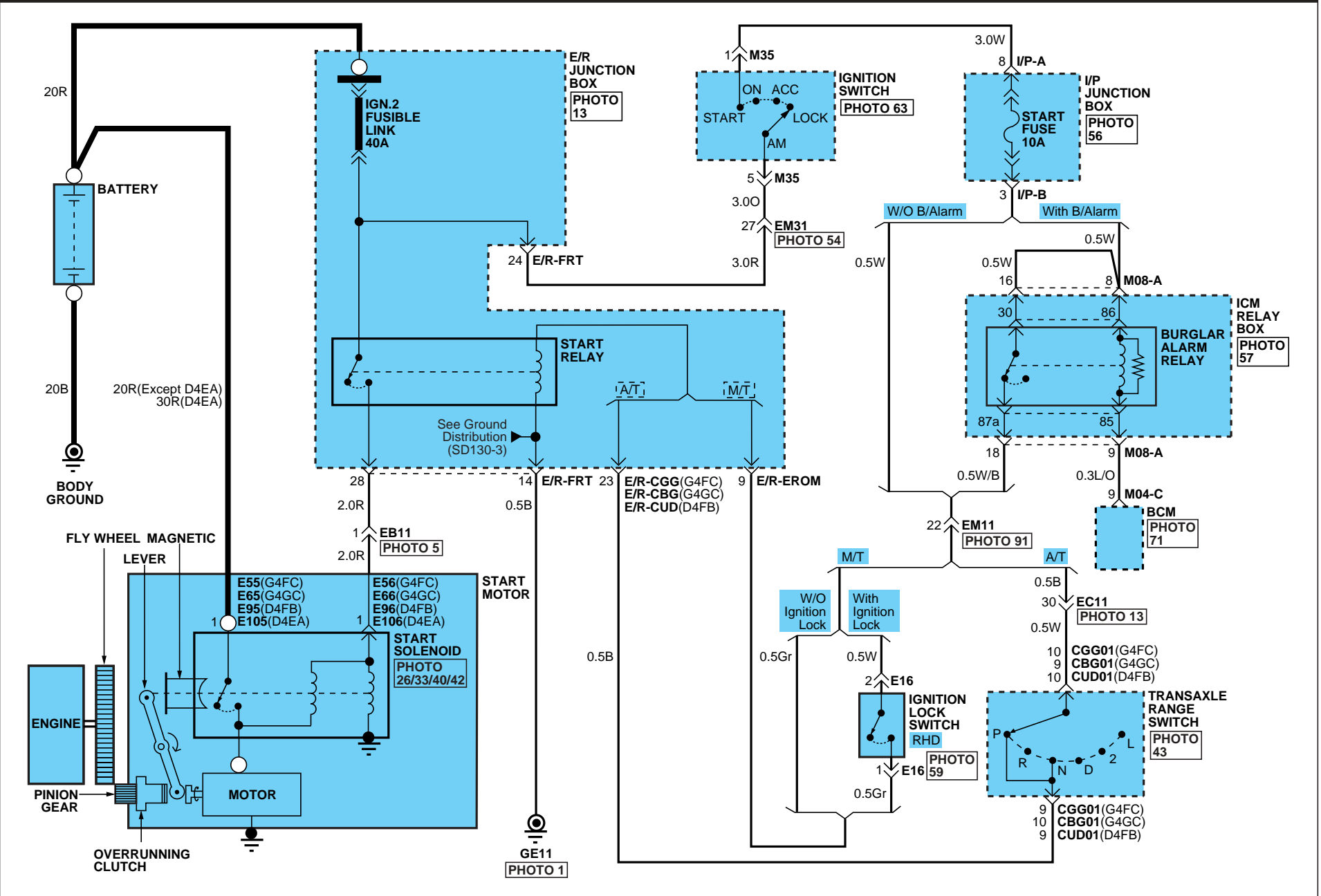

STARTING SYSTEM

STARTING SYSTEM (2)

SD360-2

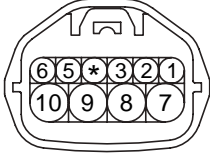
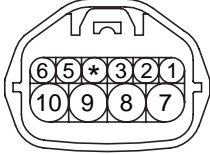
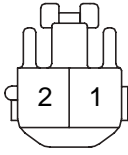
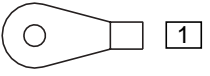
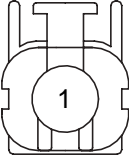
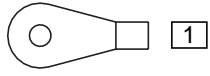
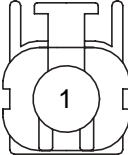
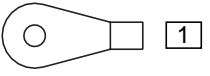
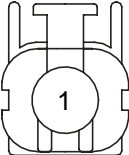
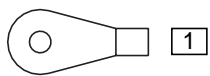
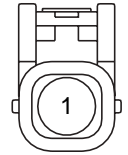
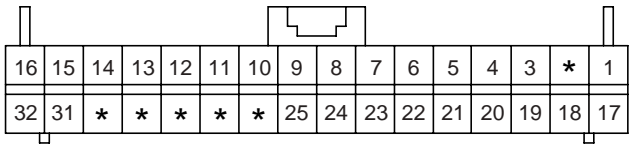
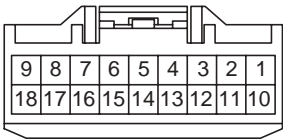
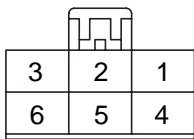
<p>CGG01</p>  <p>KET_SSD_10F_B_A</p>	<p>CBG01</p>  <p>KET_SSD_10F_B_A</p>	<p>CUD01</p>  <p>KET_SSD_10F_B_A</p>	<p>E16</p>  <p>KET_090II_02F_W_L</p>
<p>E55</p>  <p>CHT_STMTR_8T_N</p>	<p>E56</p>  <p>KET_58X_01F_B</p>	<p>E65</p>  <p>CHT_STMTR_8T_N</p>	<p>E66</p>  <p>KET_58X_01F_B</p>
<p>E95</p>  <p>CHT_STMTR_8T_N</p>	<p>E96</p>  <p>KET_58X_01F_B</p>	<p>E105</p>  <p>CHT_STMTR_8T_N</p>	<p>E106</p>  <p>AMP_187WP_01F_B</p>
<p>M04-C</p>  <p>AMP_025_32F_W</p>		<p>M08-A</p>  <p>AMP_090III_18F_W</p>	<p>M35</p>  <p>KUM_DSD_06F_W</p>

FUEL FILTER HEATING SYSTEM (D4FB/D4EA) (1)

SD361-1

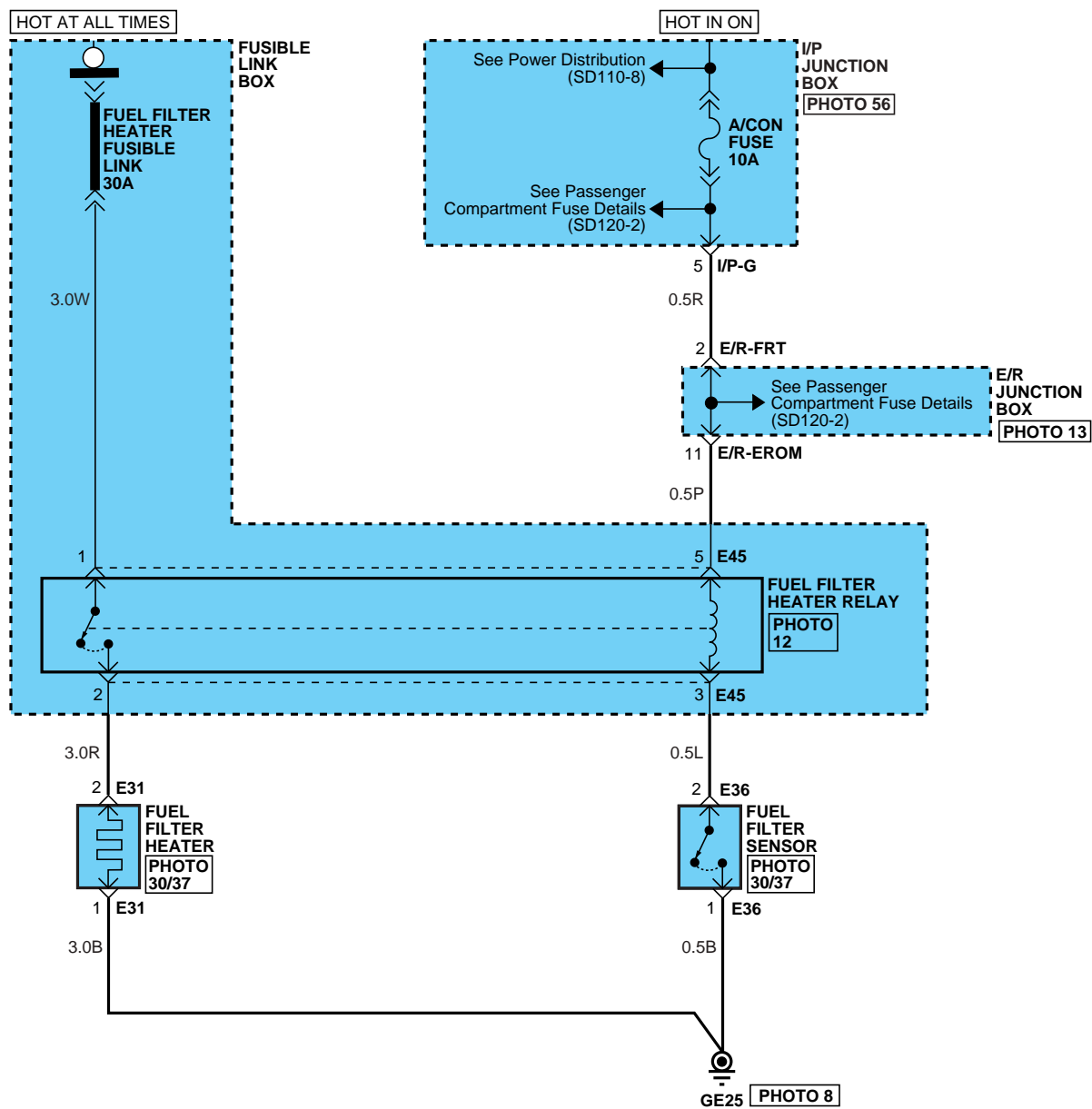

FUEL FILTER HEATING SYSTEM

FUEL FILTER HEATING SYSTEM (D4FB/D4EA) (2)

SD361-2

E31

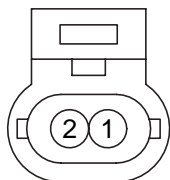

PKD_280WP_02F_B_1

E36

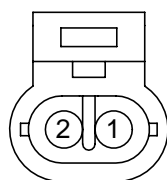

AMP_060WP_02F_B

E45

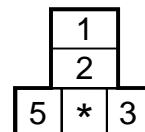

CR05F011

BLANK

CHARGING SYSTEM (1)

SD373-1

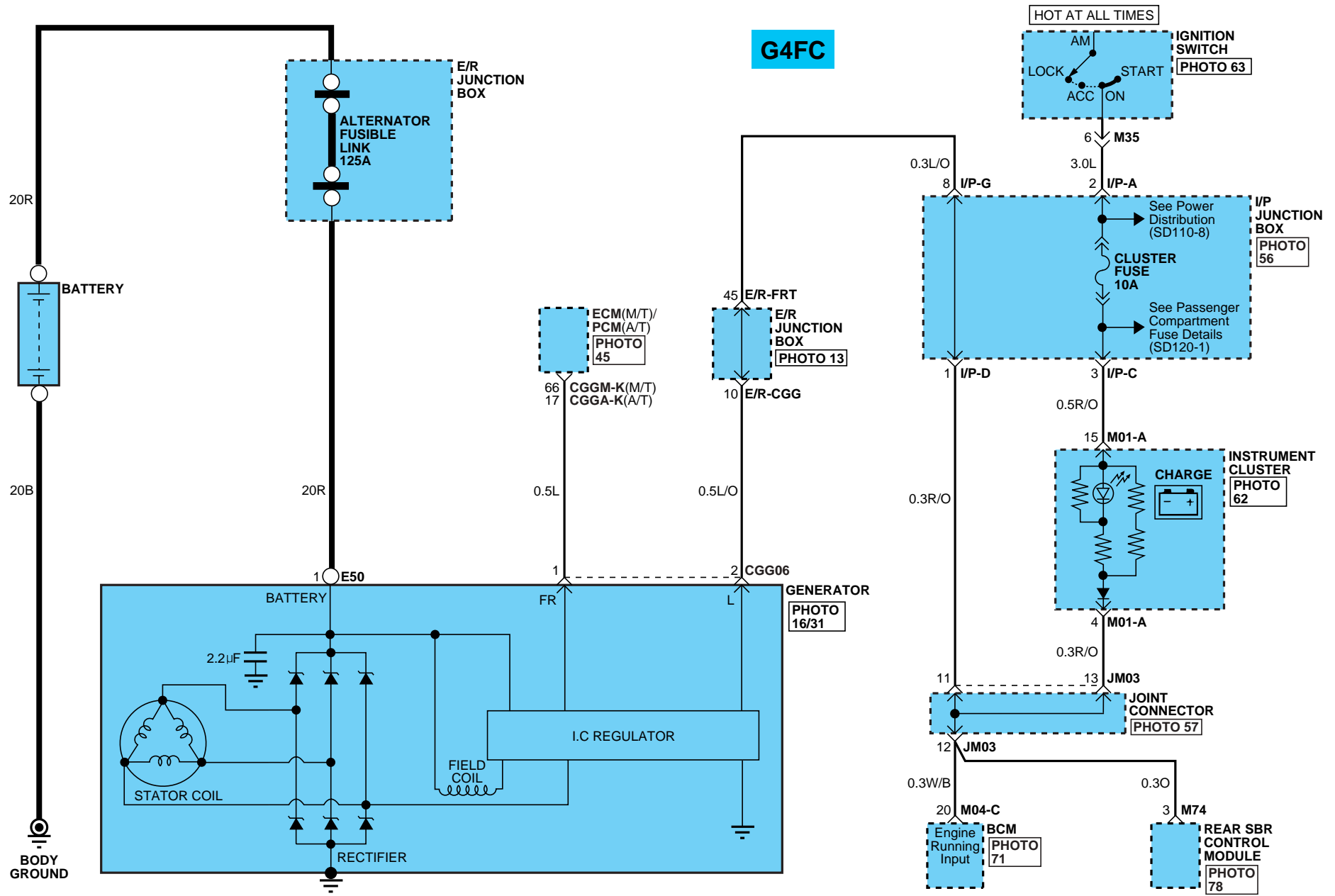

CHARGING SYSTEM

CHARGING SYSTEM (2)

SD373-2

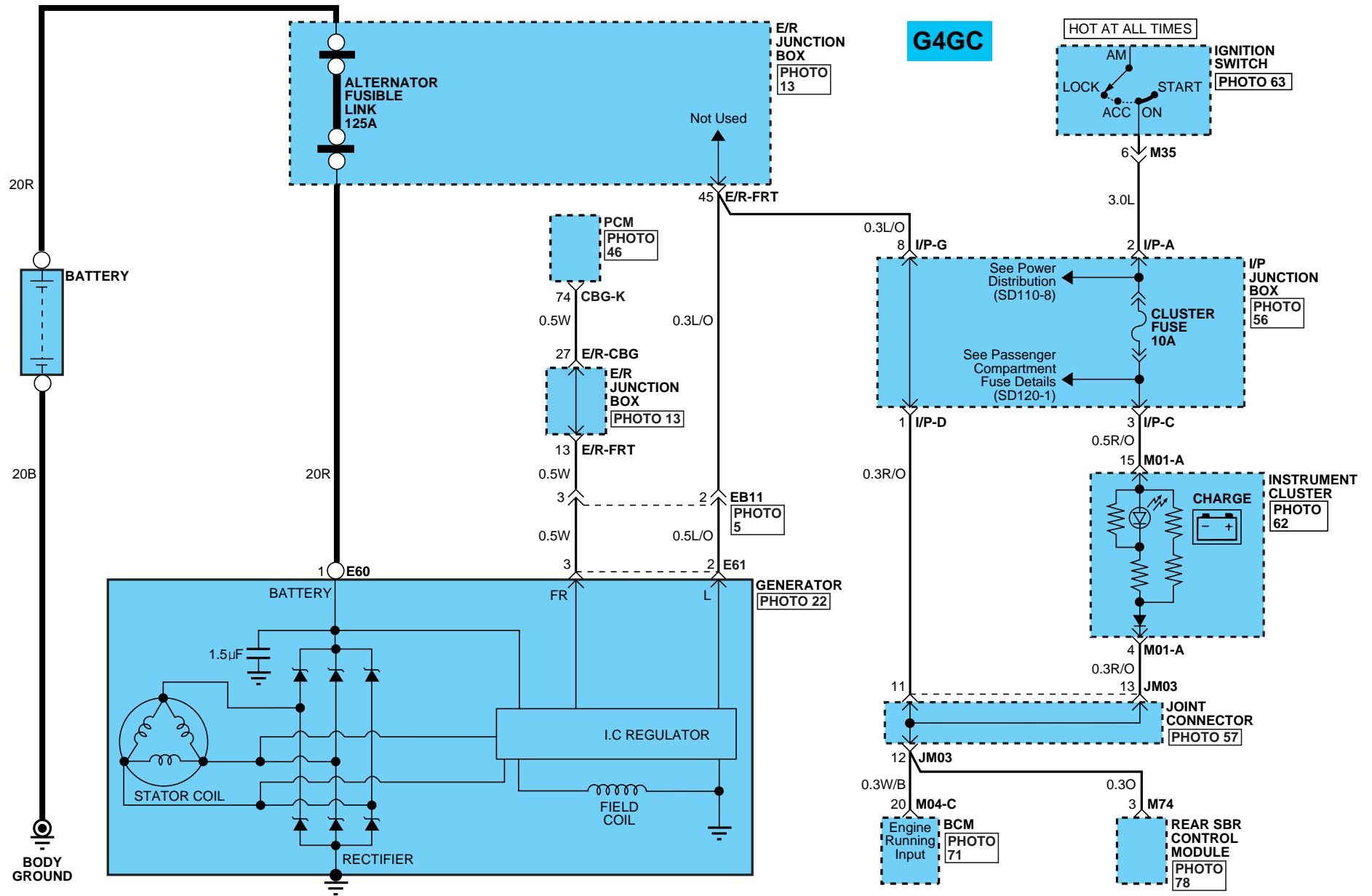

CHARGING SYSTEM

CHARGING SYSTEM (3)

SD373-3

D4FB

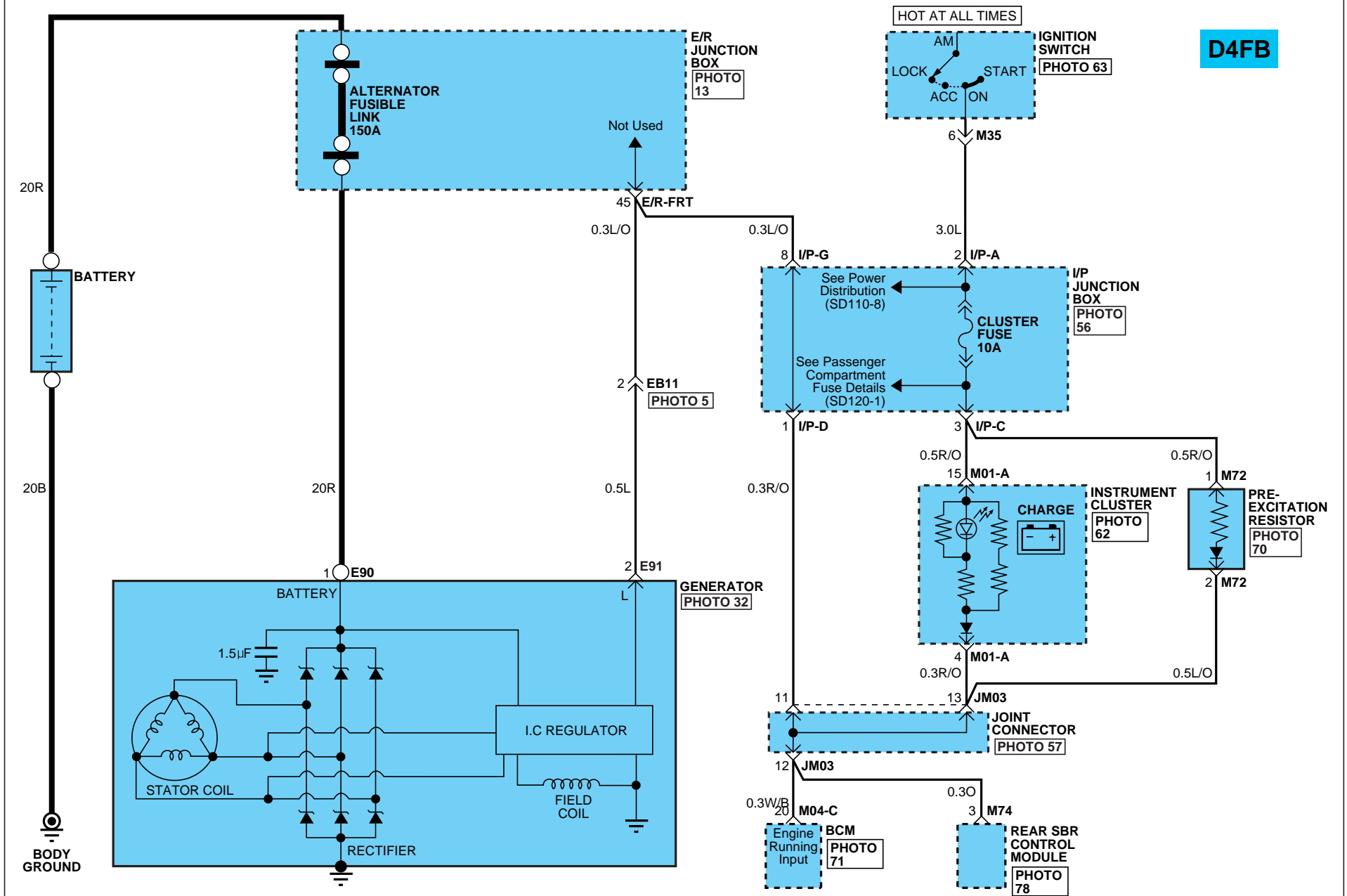

CHARGING SYSTEM

CHARGING SYSTEM (4)

SD373-4

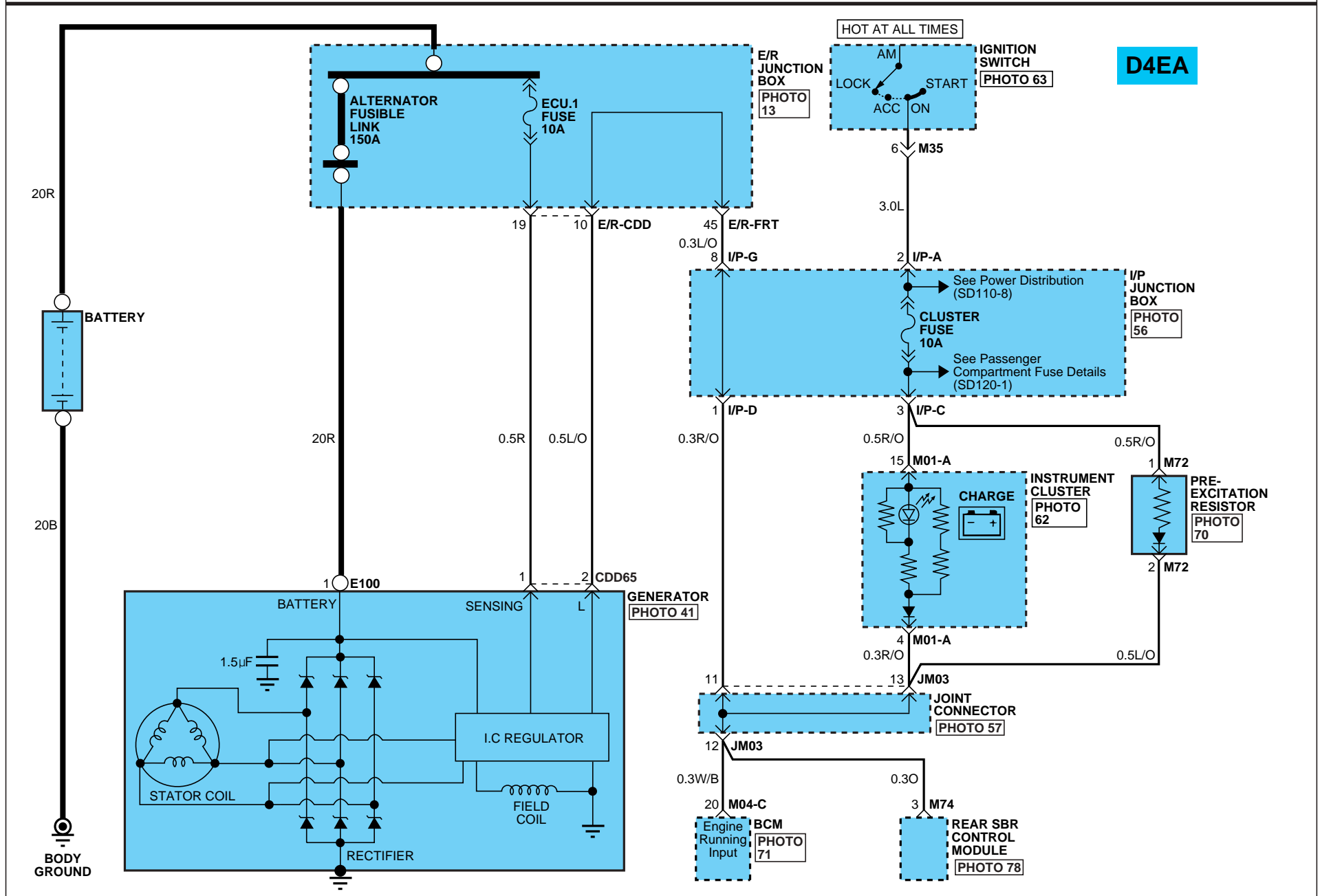

CHARGING SYSTEM

CHARGING SYSTEM (5)

SD373-5

CGGA-K

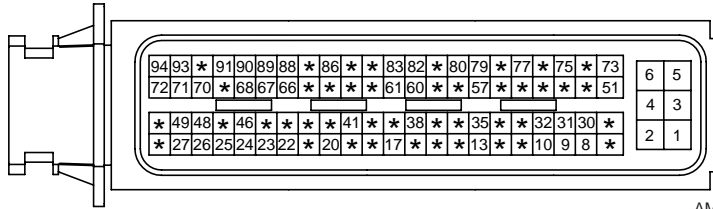

AMP_ECU_94F_B

CGGM-K

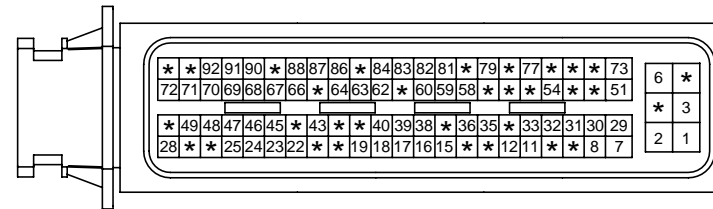

AMP_ECU_94F_B

CBG-K

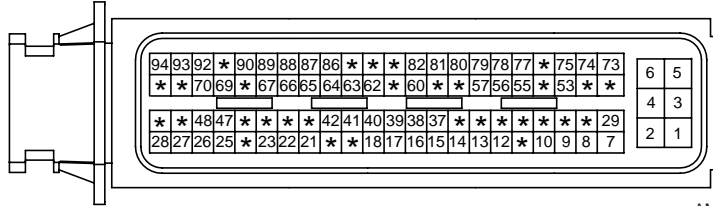

AMP_ECU_94F_B

CGG06

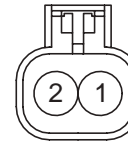

KET_58X_02F_Gr

CDD65

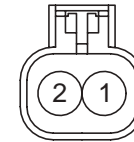

KET_58X_02F_Gr

E50/E60

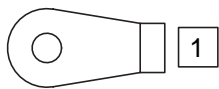

CR01F052

E61

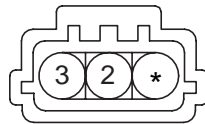

SUM_ALTWP_03F_B

E90

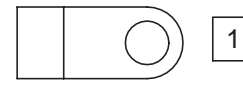

CR01F023

E91

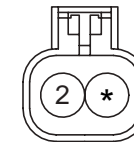

KET_58X_02F_Gr

E100



CR01F023

M01-A

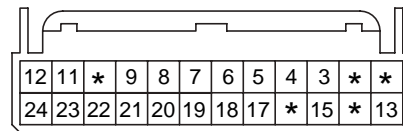

AMP_025_24F_W

M04-C

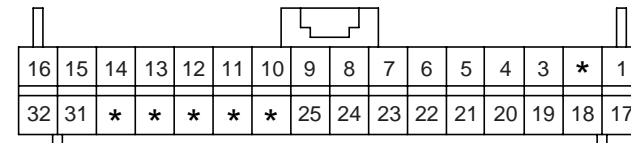

AMP_025_32F_W

M35

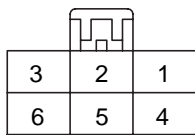

KUM_DSD_06F_W

M72

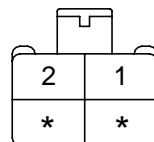

KET_250_04F_W

M74

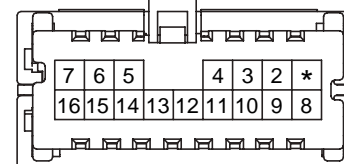

KET_040III_16F_W

BLANK

CHARGING SYSTEM

CHARGING SYSTEM (6)

SD373-6

MEMO

VEHICLE SPEED SENSOR (1)

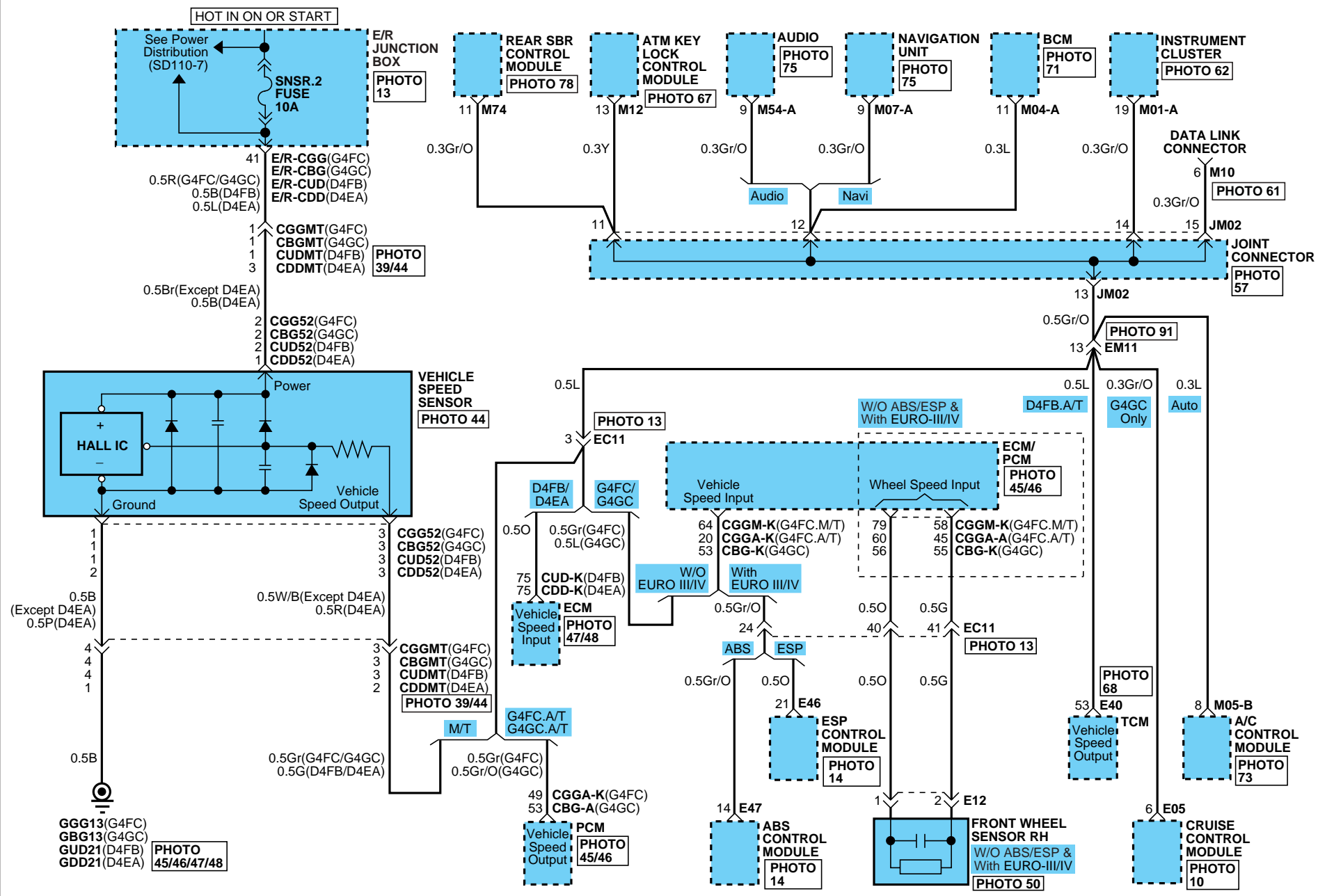

VEHICLE SPEED SENSOR

VEHICLE SPEED SENSOR (2)

SD436-2

CGGA-A

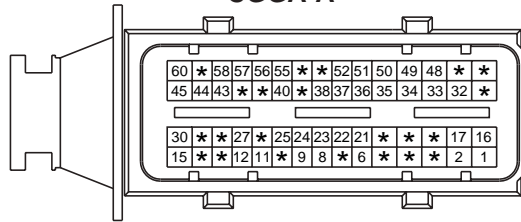

AMP_ECU_60F_B

CGGA-K

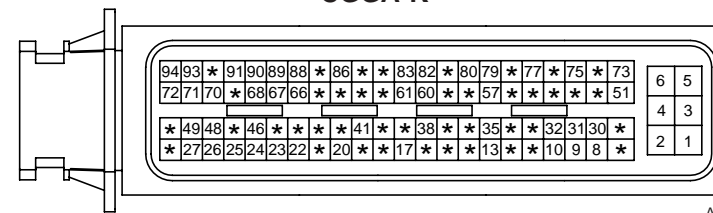

AMP_ECU_94F_B

CGGM-K

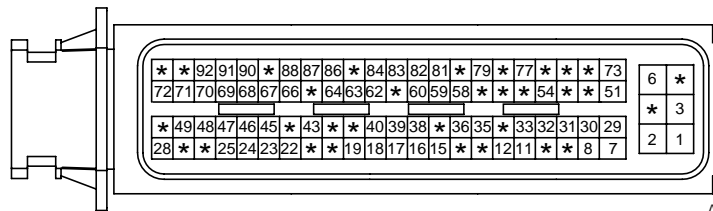

AMP_ECU_94F_B

CBG-A

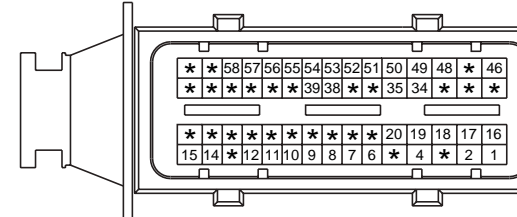

AMP_ECU_60F_B

CBG-K

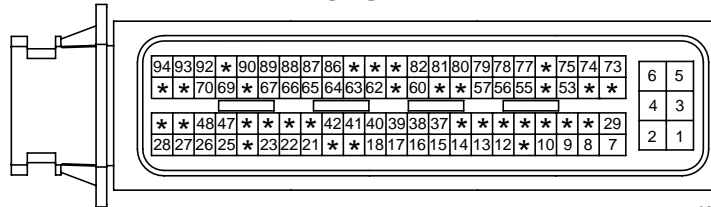

AMP_ECU_94F_B

CUD-K

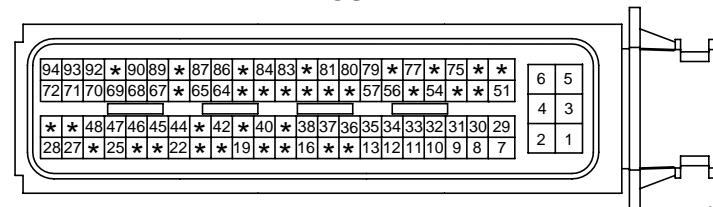

AMP_ECU_94F_B

CDD-K

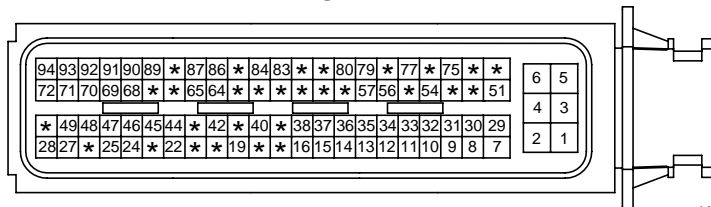

AMP_ECU_94F_B

CGG52

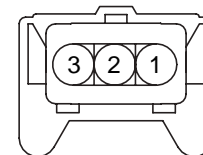

AMP_JPT_03F_B_S1

CBG52

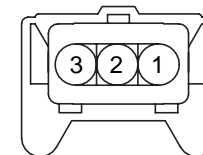

AMP_JPT_03F_B_S1

CUD52

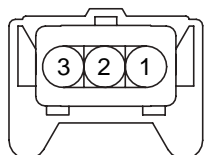

AMP_JPT_03F_B_S1

CDD52

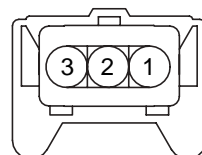

AMP_JPT_03F_B_S1

E05

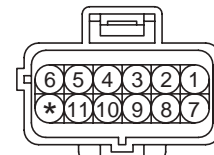

AMP_EJWP_12F_B

E12

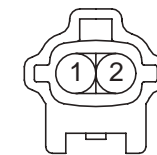

KET_090IWP_02M_Gr

VEHICLE SPEED SENSOR

VEHICLE SPEED SENSOR (3)

SD436-3

E40

6	7	8	9	10	*	12	*	14	*	*	*	18	19	20	21	22	23	24	5	4	
*	*	*	*	*	*	*	*	*	*	*	36	37	38	*	*	*	*	*		3	
44	*	*	*	*	*	*	*	52	53	*	*	*	*	58	59	*	61	62			
*	*	*	*	*	*	*	*	*	*	*	74	*	*	*	78	*	*	*	2	1	

KET_ECU_81F_B_BOSCH

E46

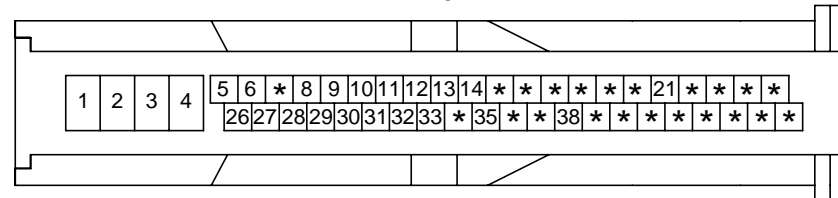

BOS_ESP_46F_B_L

E47

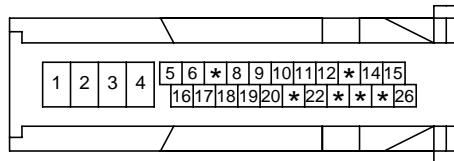

BOS_ABS_26F_B_L

M01-A

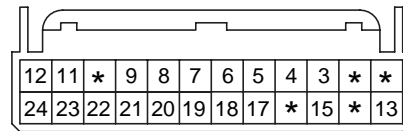

AMP_025_24F_W

M04-A

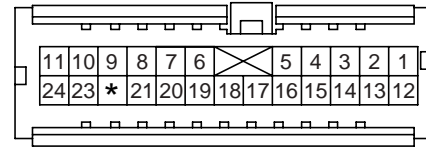

AMP_040III_24F_W

M05-B

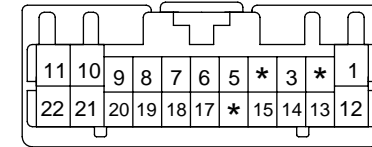

KET_0407_22F_W

M07-A

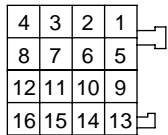

CWB_CY_16F_B

M10

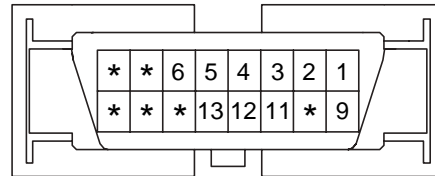

MLX_OBDII_16F_B

M12

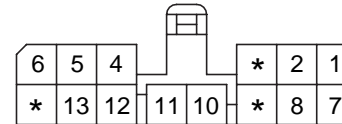

AMP_070_14F_W

M54-A

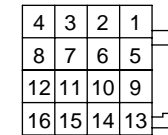

CWB_CY_16F_B

M74

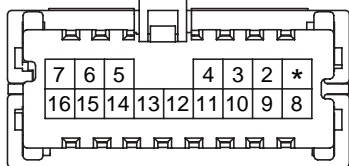

KET_040III_16F_W

BLANK

BLANK

BLANK

VEHICLE SPEED SENSOR

VEHICLE SPEED SENSOR (4)

SD436-4

MEMO

AUTOMATIC TRANSAXLE CONTROL SYSTEM (G4FC) (1)

SD450-1

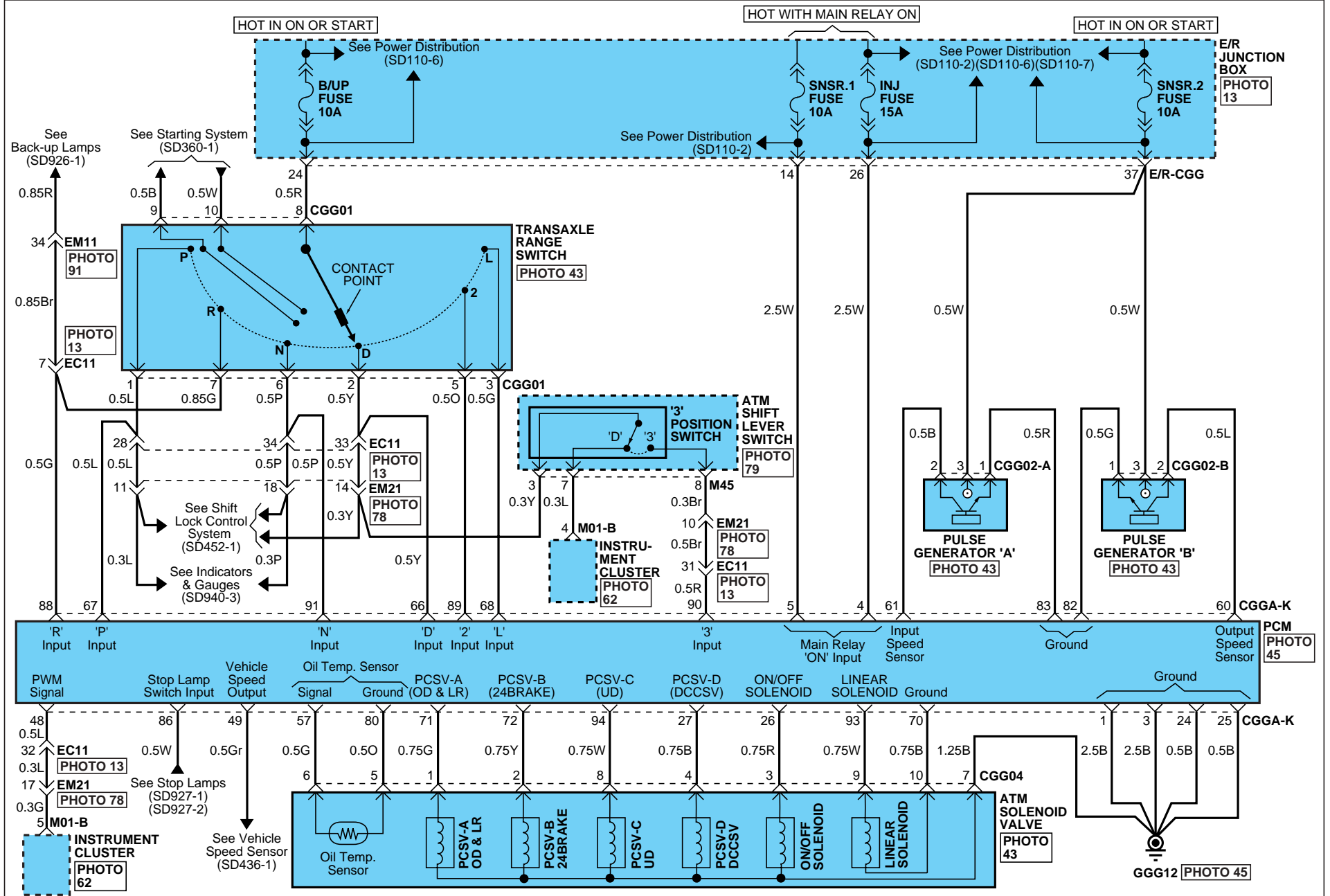

AUTOMATIC TRANSAXLE CONTROL SYSTEM

AUTOMATIC TRANSAXLE CONTROL SYSTEM (G4FC) (2)

SD450-2

CGGA-K

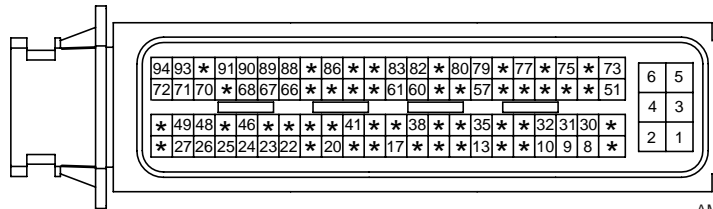

AMP_ECU_94F_B

CGG01



KET_SSD_10F_B_A

CGG02-A

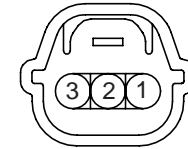

KET_SSD_03F_Gr_B

CGG02-B

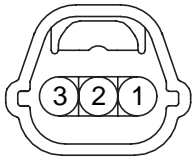

KET_SSD_03F_B_A

CGG04

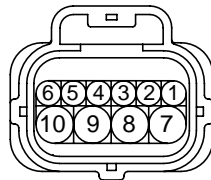

FCI_FPC_10F_B

M01-B

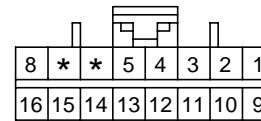

AMP_040M2_16F_B

M45

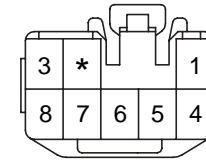

KET_090II_08F_B

AUTOMATIC TRANSAXLE CONTROL SYSTEM (G4GC) (1)

SD450-3

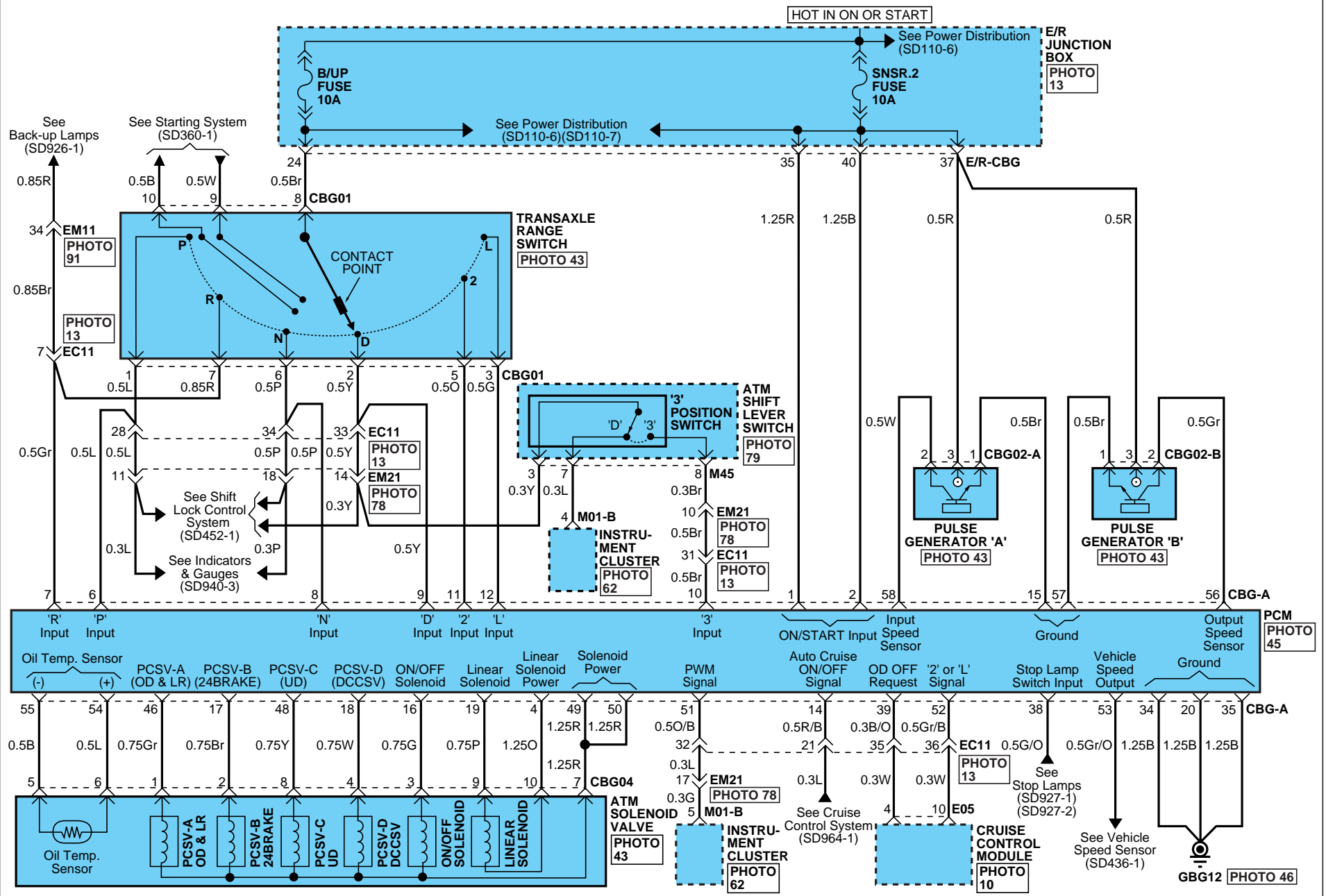

AUTOMATIC TRANSAXLE CONTROL SYSTEM

AUTOMATIC TRANSAXLE CONTROL SYSTEM (G4GC) (2)

SD450-4

CBG-A

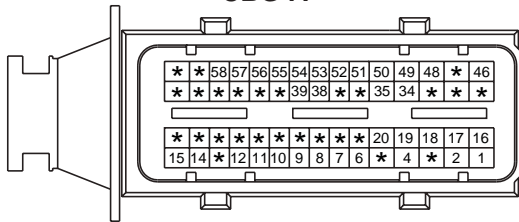

AMP_ECU_60F_B

CBG01



KET_SSD_10F_B_A

CBG02-A



KET_SSD_03F_Gr_B

CBG02-B



KET_SSD_03F_B_A

CBG04

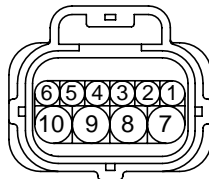

FCI_FPC_10F_B

E05

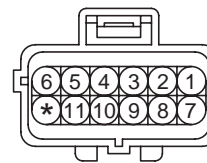

AMP_EJWP_12F_B

M01-B

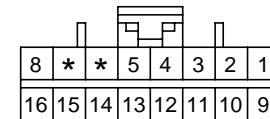

AMP_040M2_16F_B

M45

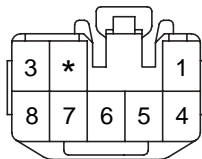

KET_0901I_08F_B

BLANK

BLANK

BLANK

AUTOMATIC TRANSAXLE CONTROL SYSTEM (D4FB) (1)

SD450-5

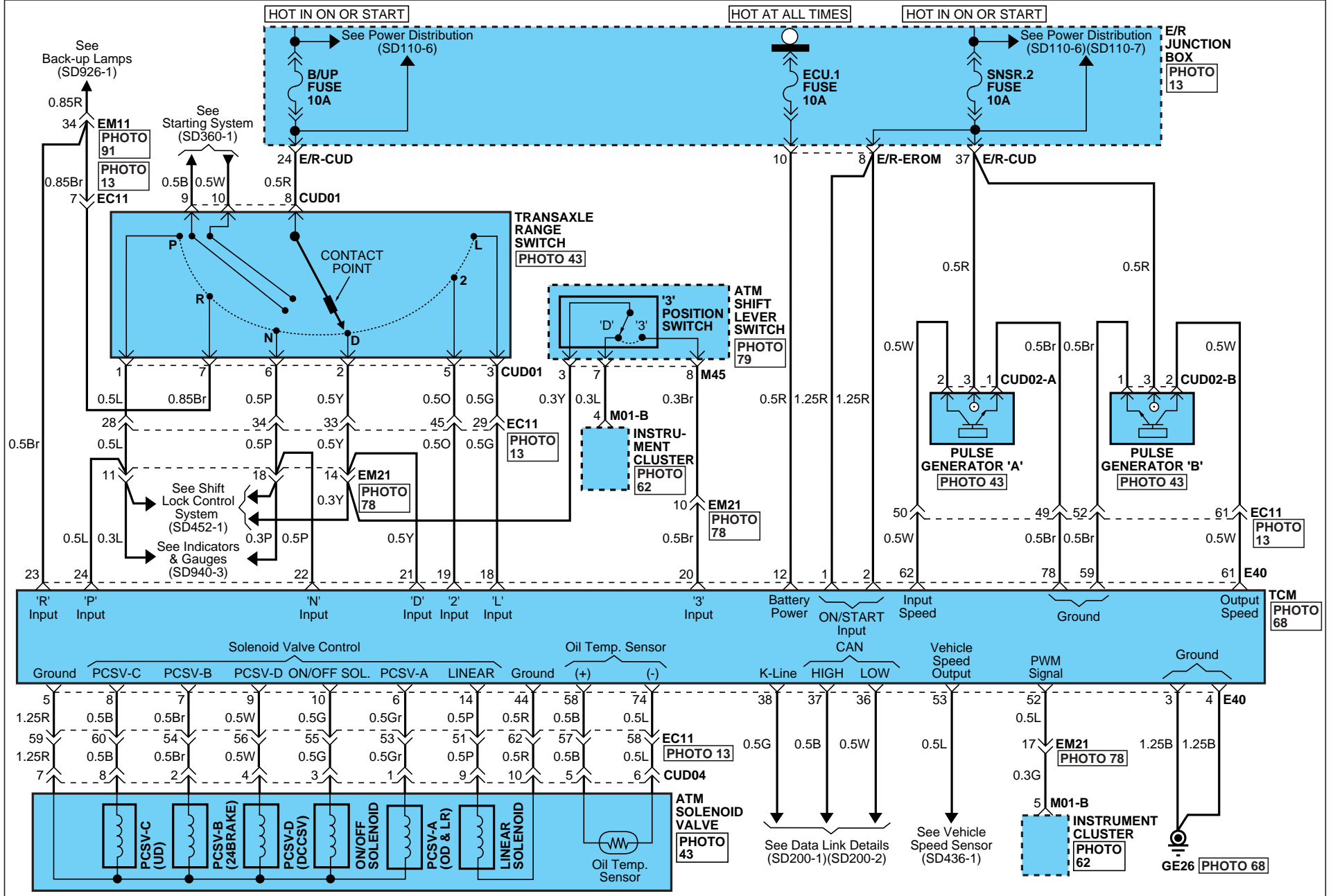

AUTOMATIC TRANSAXLE CONTROL SYSTEM

AUTOMATIC TRANSAXLE CONTROL SYSTEM (D4FB) (2)

SD450-6

CUD01



KET_SSD_10F_B_A

CUD02-A

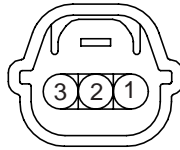

KET_SSD_03F_Gr_B

CUD02-B

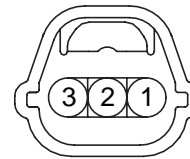

KET_SSD_03F_B_A

CUD04

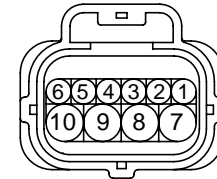

FCI_FPC_10F_B

E40

6	7	8	9	10	*	12	*	14	*	*	*	18	19	20	21	22	23	24	5	4	
*	*	*	*	*	*	*	*	*	*	*	*	36	37	38	*	*	*	*	*	3	
44	*	*	*	*	*	*	*	52	53	*	*	*	*	58	59	*	61	62			
*	*	*	*	*	*	*	*	*	*	*	74	*	*	*	78	*	*	*	2	1	

KET_ECU_81F_B_BOSCH

M01-B

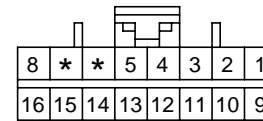

AMP_040M2_16F_B

M45

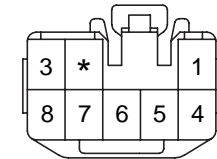

KET_090II_08F_B

SHIFT LOCK CONTROL SYSTEM (1)

SD452-1

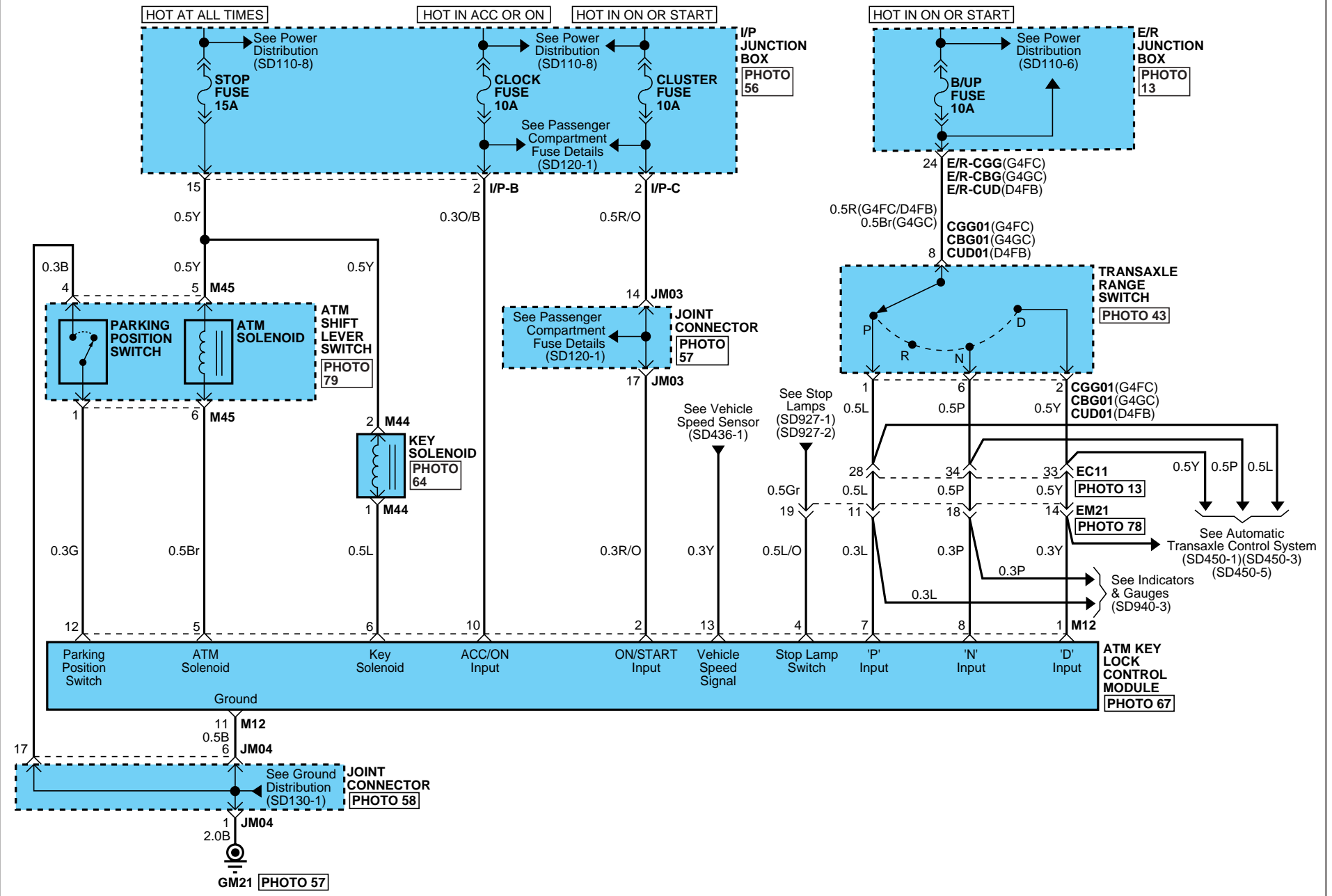

SHIFT LOCK CONTROL SYSTEM

SHIFT LOCK CONTROL SYSTEM (2)

SD452-2

CGG01



KET_SSD_10F_B_A

CBG01



KET_SSD_10F_B_A

CUD01



KET_SSD_10F_B_A

M12

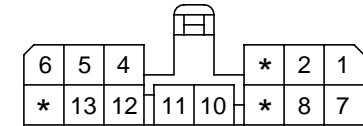

AMP_070_14F_W

M44

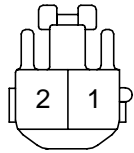

KET_090II_02F_B_R

M45

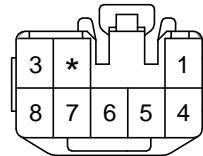

KET_090II_08F_B

BLANK

BLANK

EPS (ELECTRONIC POWER STEERING) SYSTEM - MDPS (1)

SD563-1

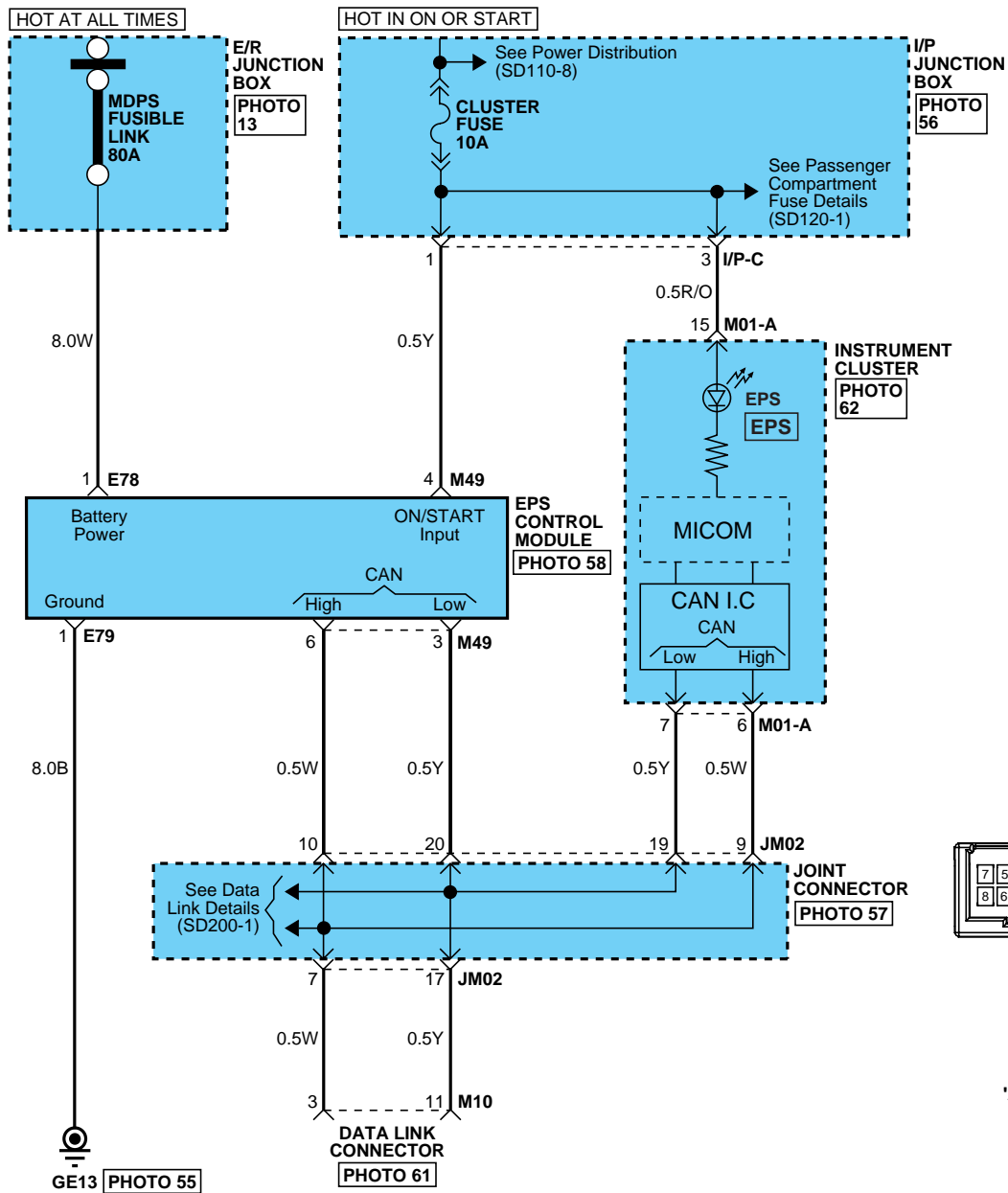

MDPS: Motor Driven Power Steering

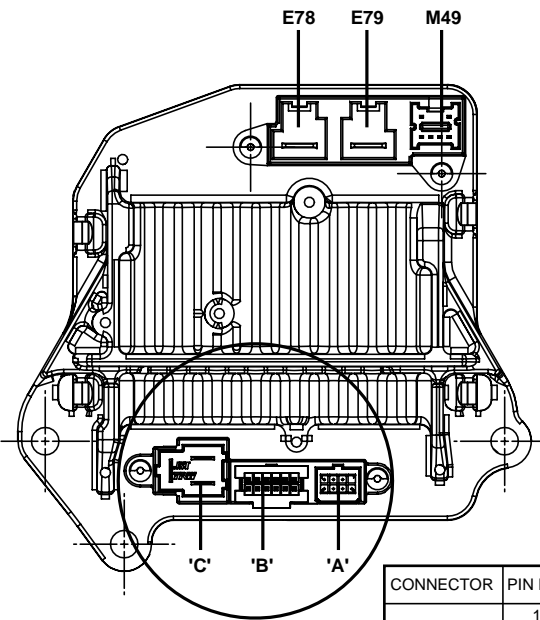

CONNECTOR	PIN NO.	CIRCUIT
A	1	LA_CHAN_B
	2	LA_CLK_LSD
	3	OV
	4	LED_DRV
	5	5V
	6	LA_SI_LSD
	7	NO PIN
	8	LA_CHAN_A
B	1	OV ENCODER
	2	5V ENCODER
	3	OV HALL
	4	ENCODER_B
	5	VLINK
	6	5V_HALL
	7	V_STAR
	8	MOT_RLY
	9	ENCODER_A
	10	HALL_C
	11	HALL_A
	12	HALL_B
C	1	MOTOR PHASE 3
	2	MOTOR PHASE 1
	3	MOTOR PHASE 2

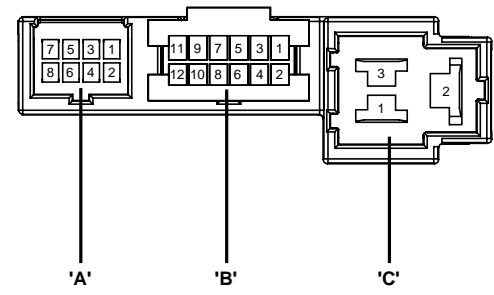

EPS (ELECTRONIC POWER STEERING) SYSTEM - MDPS

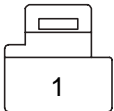
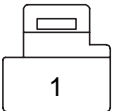
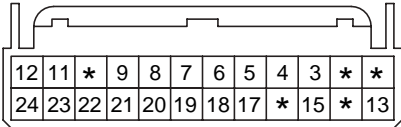
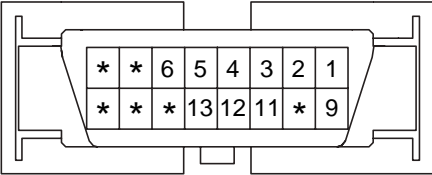
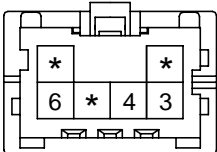
EPS (ELECTRONIC POWER STEERING) SYSTEM - MDPS (2)			SD563-2																																								
<p style="text-align: center;">E78</p> <div style="text-align: center;">  <p>1</p> </div> <p style="text-align: right; font-size: small;">YAZ_375R_01F_B</p>	<p style="text-align: center;">E79</p> <div style="text-align: center;">  <p>1</p> </div> <p style="text-align: right; font-size: small;">YAZ_375L_01F_W</p>	<p style="text-align: center;">M01-A</p> <div style="text-align: center;">  <table border="1" style="margin: auto; font-size: x-small;"> <tr> <td>12</td><td>11</td><td>*</td><td>9</td><td>8</td><td>7</td><td>6</td><td>5</td><td>4</td><td>3</td><td>*</td><td>*</td> </tr> <tr> <td>24</td><td>23</td><td>22</td><td>21</td><td>20</td><td>19</td><td>18</td><td>17</td><td>*</td><td>15</td><td>*</td><td>13</td> </tr> </table> </div> <p style="text-align: right; font-size: small;">AMP_025_24F_W</p>	12	11	*	9	8	7	6	5	4	3	*	*	24	23	22	21	20	19	18	17	*	15	*	13	<p style="text-align: center;">M10</p> <div style="text-align: center;">  <table border="1" style="margin: auto; font-size: x-small;"> <tr> <td>*</td><td>*</td><td>6</td><td>5</td><td>4</td><td>3</td><td>2</td><td>1</td> </tr> <tr> <td>*</td><td>*</td><td>*</td><td>13</td><td>12</td><td>11</td><td>*</td><td>9</td> </tr> </table> </div> <p style="text-align: right; font-size: small;">MLX_OBDII_16F_B</p>	*	*	6	5	4	3	2	1	*	*	*	13	12	11	*	9
12	11	*	9	8	7	6	5	4	3	*	*																																
24	23	22	21	20	19	18	17	*	15	*	13																																
*	*	6	5	4	3	2	1																																				
*	*	*	13	12	11	*	9																																				
<p style="text-align: center;">M49</p> <div style="text-align: center;">  <table border="1" style="margin: auto; font-size: x-small;"> <tr> <td>*</td><td>*</td> </tr> <tr> <td>6</td><td>*</td><td>4</td><td>3</td> </tr> </table> </div> <p style="text-align: right; font-size: small;">KET_040III_06F_W</p>	*	*	6	*	4	3	<p>BLANK</p>	<p>BLANK</p>	<p>BLANK</p>																																		
*	*																																										
6	*	4	3																																								

AIR BAG SYSTEM (SRS) (1)

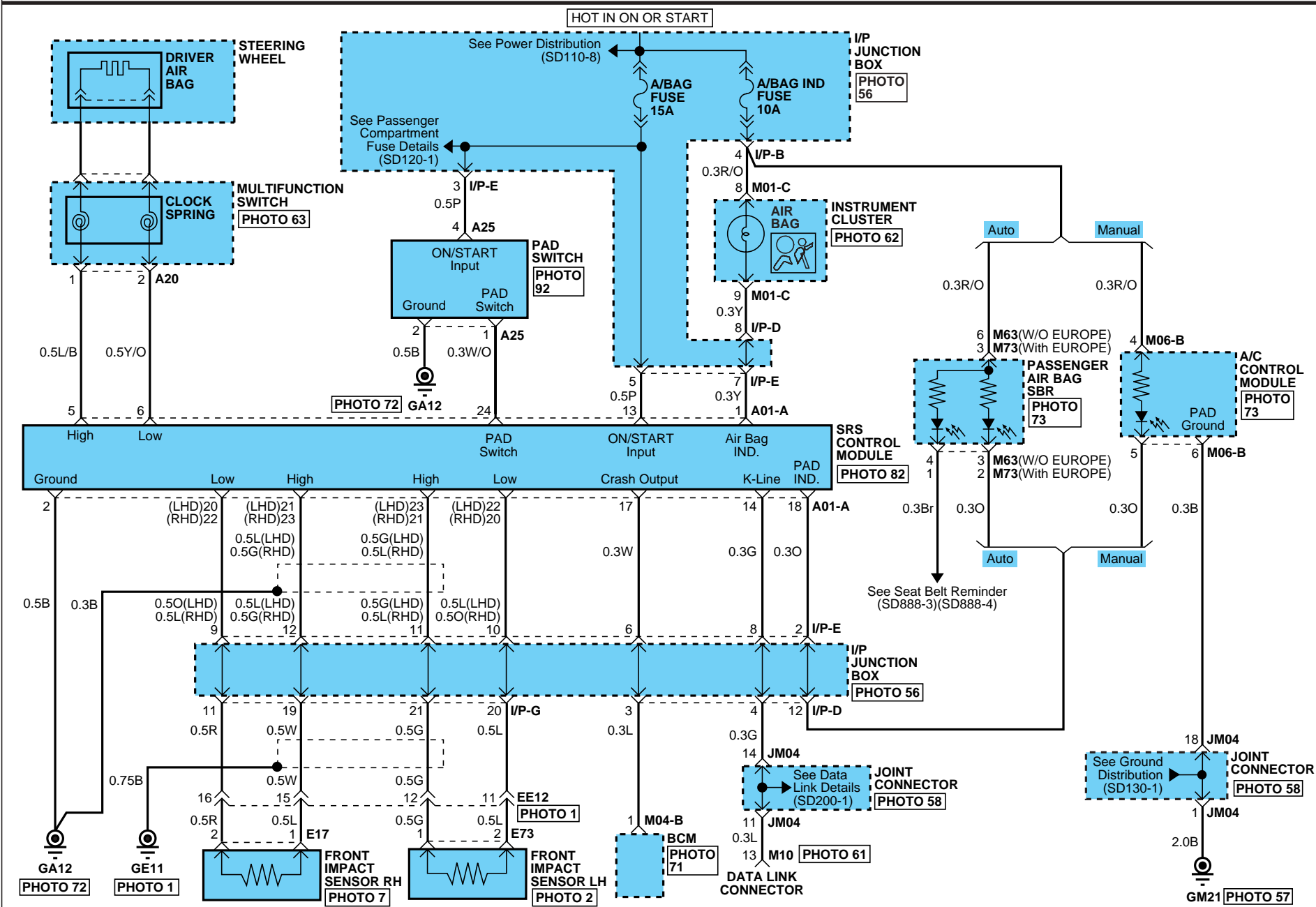

AIR BAG SYSTEM (SRS)

AIR BAG SYSTEM (SRS) (2)

SD569-2

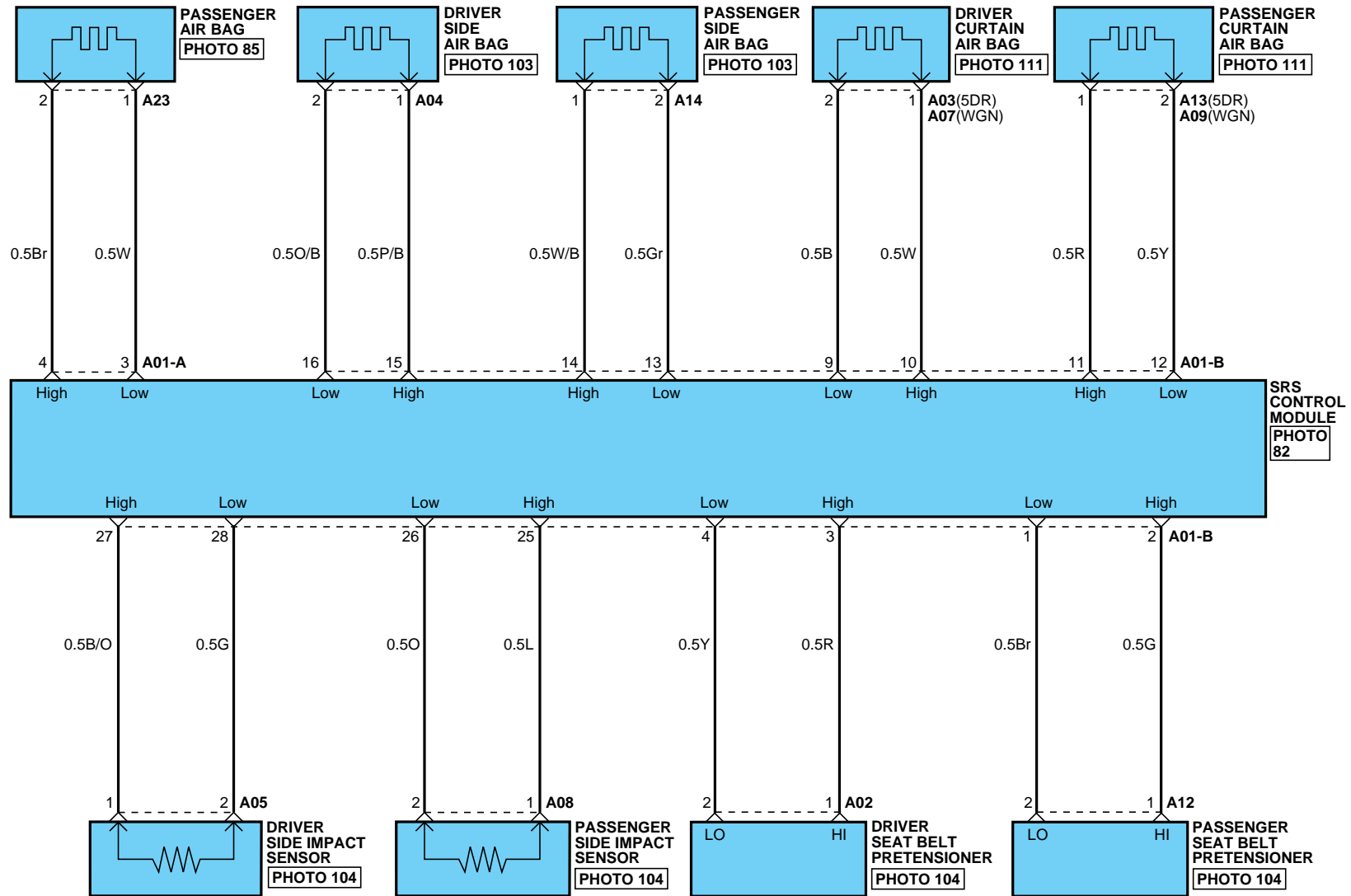

AIR BAG SYSTEM (SRS)

AIR BAG SYSTEM (SRS) (3)

SD569-3

<p>A01-A</p> <p>AMP_ABG_24F_B_ECU</p>	<p>A01-B</p> <p>AMP_ABG_32F_B_ECU</p>	<p>A02</p> <p>JST_SQS_02F_B</p>	<p>A03</p> <p>JST_SQS_02F_B</p>
<p>A04</p> <p>YAZ_040WP_02F_Y_GH</p>	<p>A05</p> <p>YAZ_040_02F_Y</p>	<p>A07</p> <p>JST_SQS_02F_B</p>	<p>A08</p> <p>YAZ_040_02F_Y</p>
<p>A09</p> <p>JST_SQS_02F_B</p>	<p>A12</p> <p>JST_SQS_02F_B</p>	<p>A13</p> <p>JST_SQS_02F_B</p>	<p>A14</p> <p>YAZ_040WP_02F_Y_GH</p>
<p>A20</p> <p>YAZ_040_04F_Y</p>	<p>A23</p> <p>JST_SQS_02F_B</p>	<p>A25</p> <p>AMP_MQS_04F_B_040</p>	<p>E17</p> <p>YAZ_ABAG_02F_Y_B</p>
<p>E73</p> <p>YAZ_ABAG_02F_Y_B</p>	<p>M01-C</p> <p>AMP_040M2_20F_B</p>	<p>M04-B</p> <p>AMP_040III_20F_W</p>	<p>BLANK</p>

AIR BAG SYSTEM (SRS)

AIR BAG SYSTEM (SRS) (4)

SD569-4

M06-B

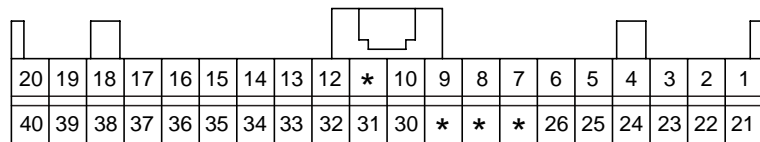

AMP_025_40F_W

M10

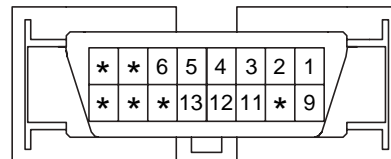

MLX_OBDII_16F_B

M63

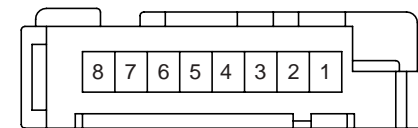

AMP_MQS_08F_W

M73

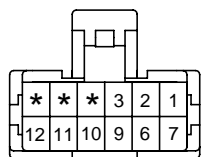

KET_SP_12F_B

BLANK

BLANK

BLANK

ABS CONTROL SYSTEM (1)

SD587-1

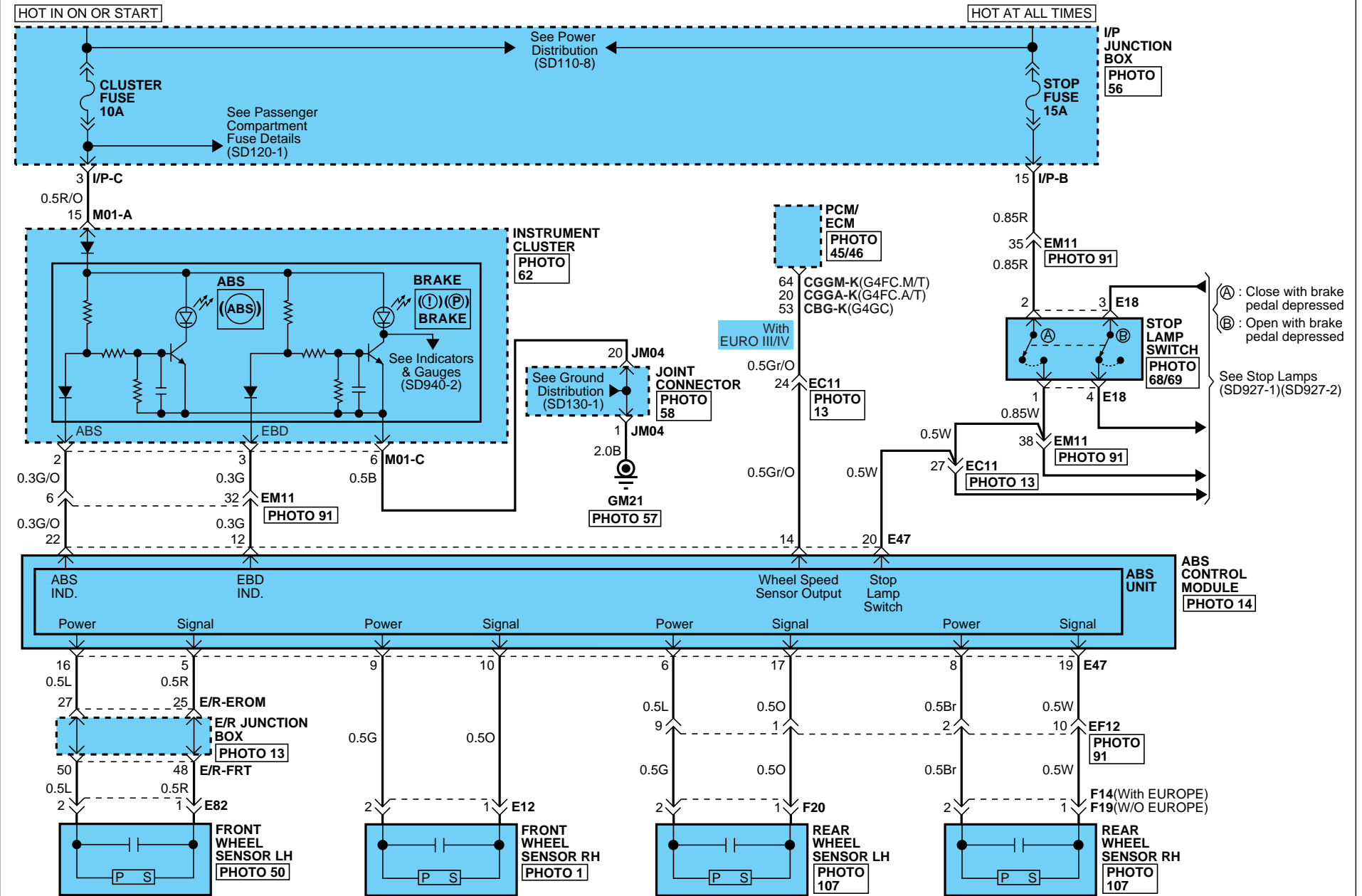

ABS CONTROL SYSTEM

ABS CONTROL SYSTEM (2)

SD587-2

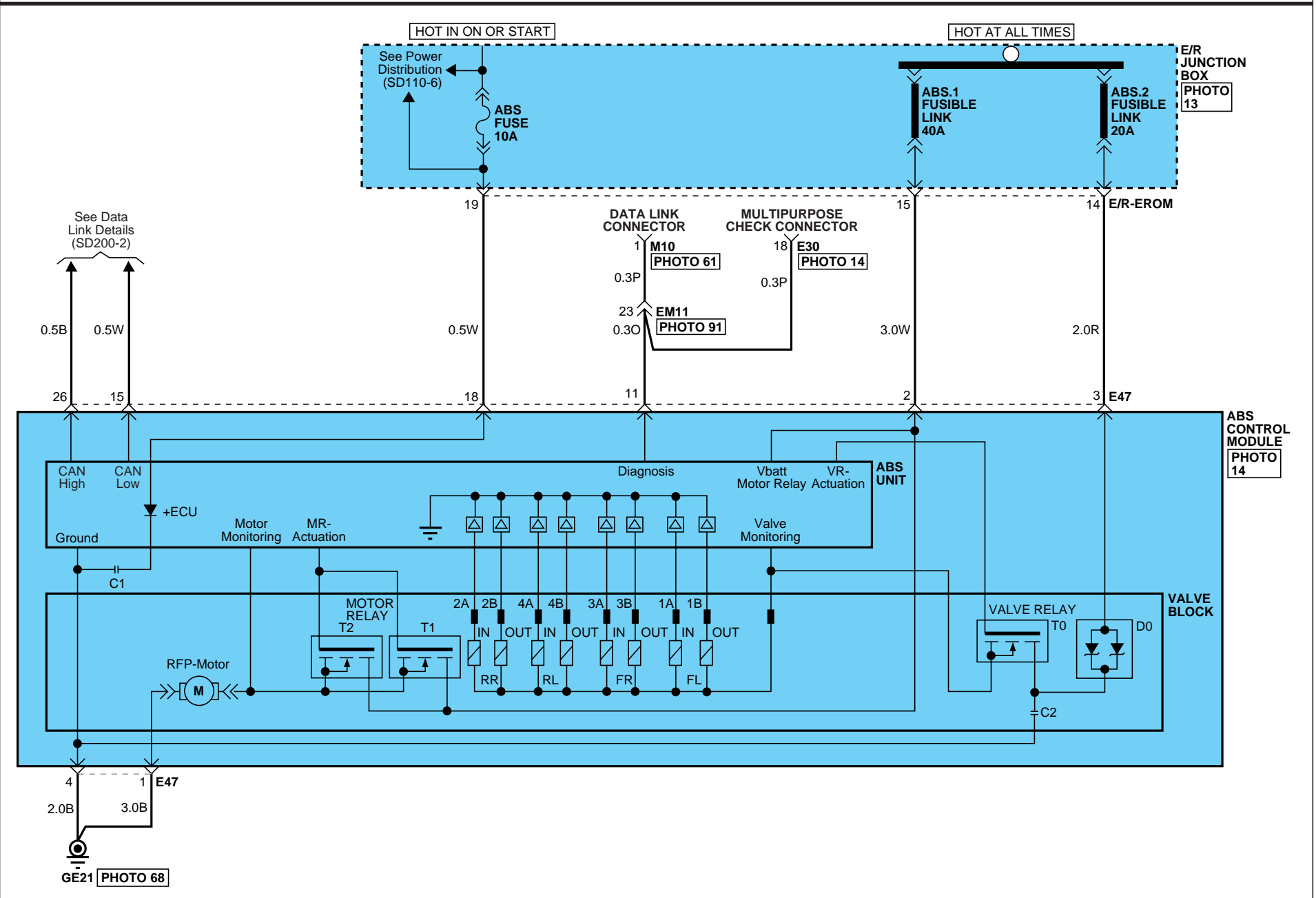

ABS CONTROL SYSTEM

ABS CONTROL SYSTEM (3)

SD587-3

CGGA-K

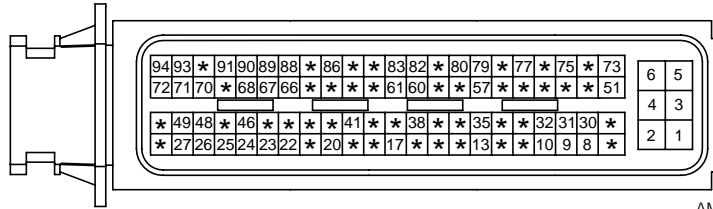

AMP_ECU_94F_B

CGGM-K

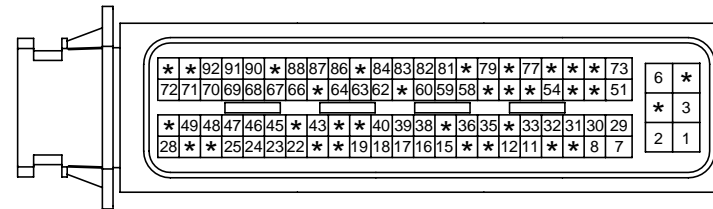

AMP_ECU_94F_B

CBG-K

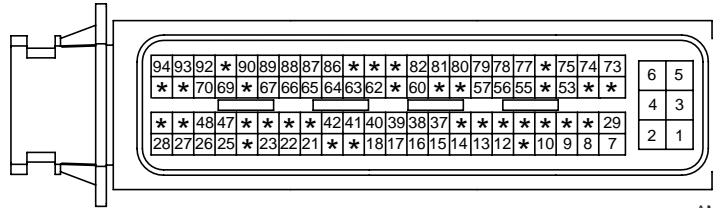

AMP_ECU_94F_B

E12

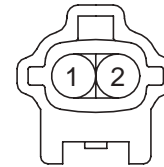

KET_090IWP_02M_Gr

E18

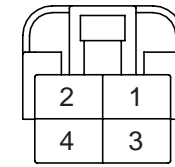

KET_250DL_04F_W

E30

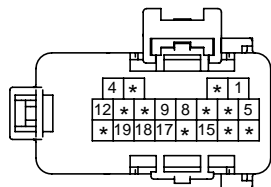

KET_DIAG_20F_B_BRK_C

E47

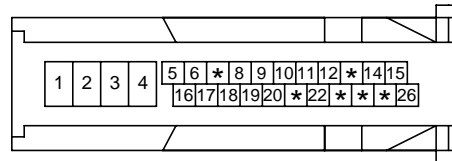

BOS_ABS_26F_B_L

E82

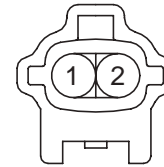

KET_090IWP_02M_Gr

F14

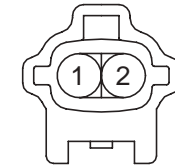

KET_090IWP_02M_Gr

F19

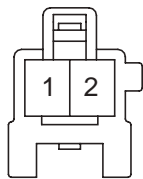

KET_090III_02M_W_L

F20

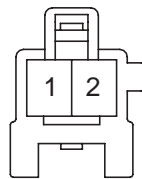

KET_090III_02M_W_L

M01-A

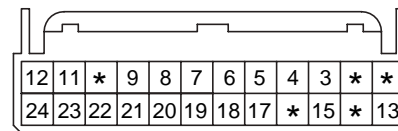

AMP_025_24F_W

M01-C

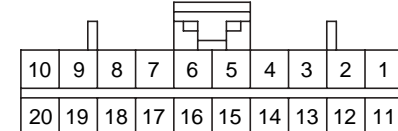

AMP_040M2_20F_B

M10

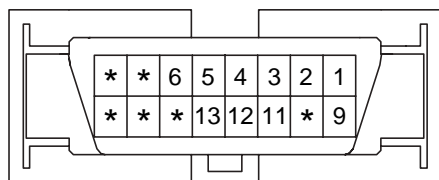

MLX_OBDII_16F_B

BLANK

BLANK

BLANK

ABS CONTROL SYSTEM

ABS CONTROL SYSTEM (4)

SD587-4

MEMO

ESP (ELECTRONIC STABILITY PROGRAM) SYSTEM (1)

SD589-1

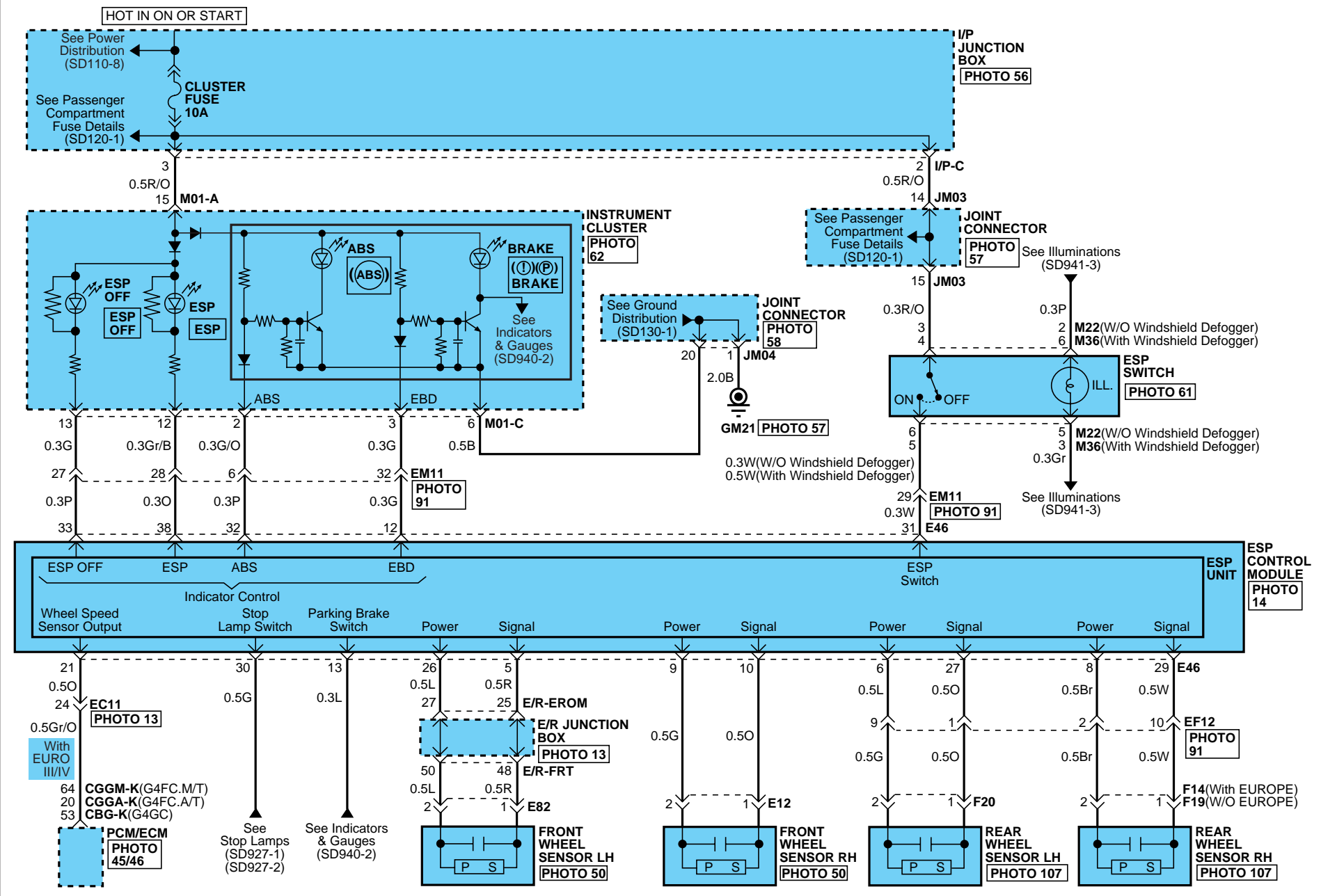

ESP (ELECTRONIC STABILITY PROGRAM) SYSTEM

ESP (ELECTRONIC STABILITY PROGRAM) SYSTEM (2)

SD589-2

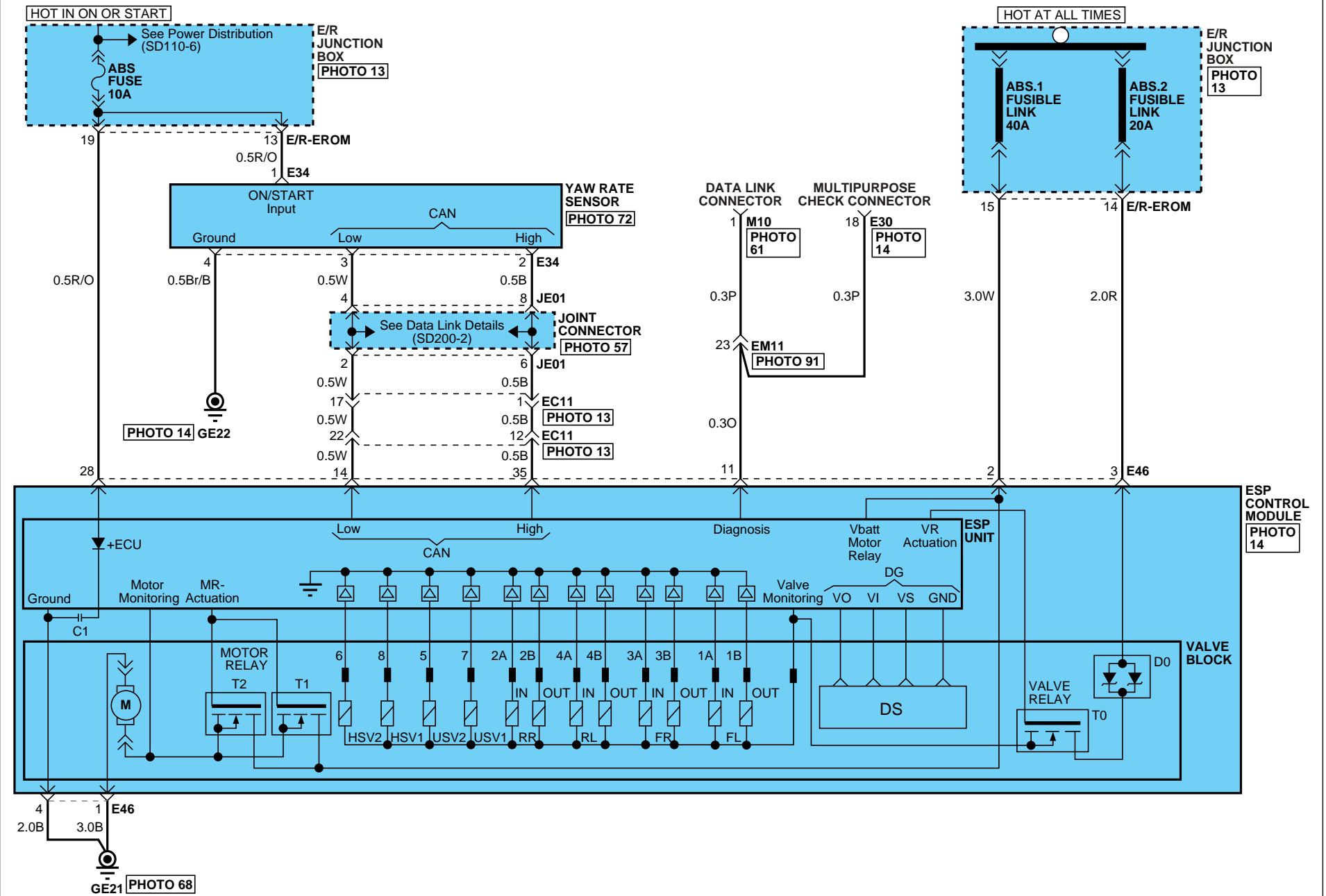

ESP (ELECTRONIC STABILITY PROGRAM) SYSTEM

ESP (ELECTRONIC STABILITY PROGRAM) SYSTEM (3)

SD589-3

CGGA-K

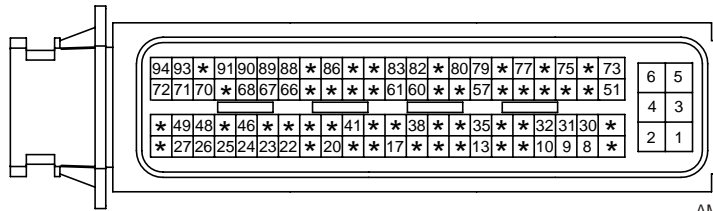

AMP_ECU_94F_B

CGGM-K

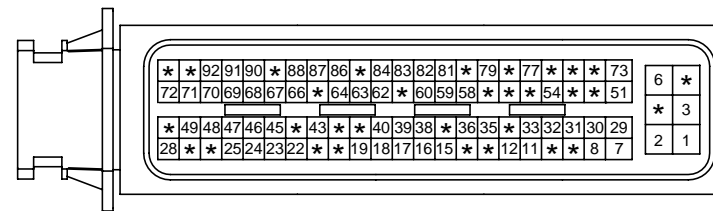

AMP_ECU_94F_B

CBG-K

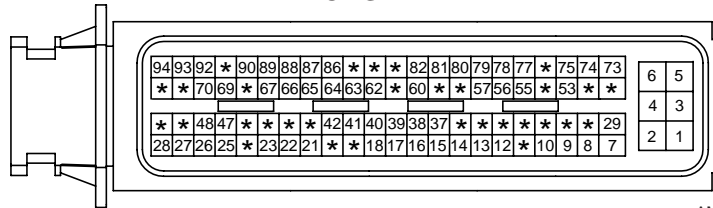

AMP_ECU_94F_B

E12

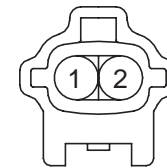

KET_090IWP_02M_Gr

E30

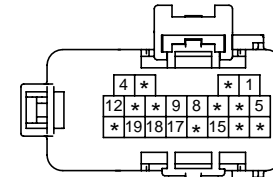

KET_DIAG_20F_B_BRK_C

E34

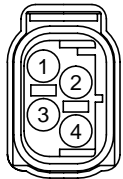

AMP_MQSWP_04F_B

E46

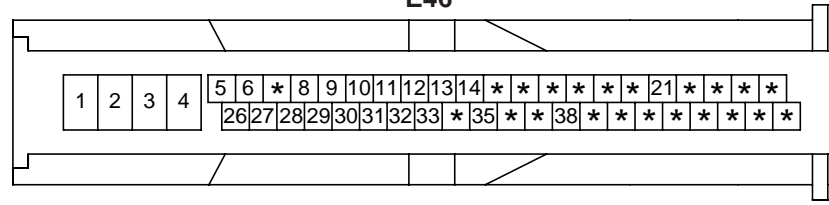

BOS_ESP_46F_B_L

E82

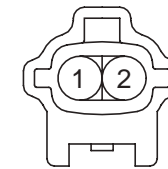

KET_090IWP_02M_Gr

F14

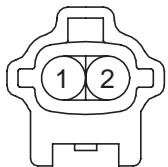

KET_090IWP_02M_Gr

F19

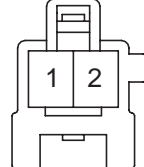

KET_090III_02M_W_L

F20

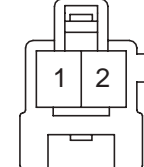

KET_090III_02M_W_L

M01-A

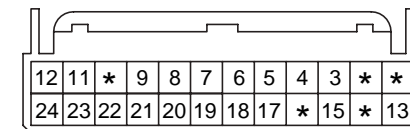

AMP_025_24F_W

M01-C

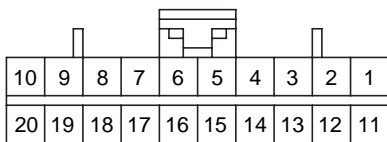

AMP_040M2_20F_B

M10

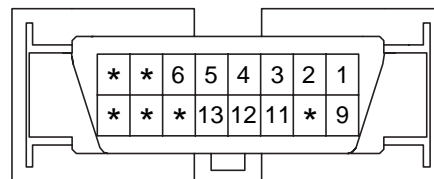

MLX_OBDII_16F_B

M22

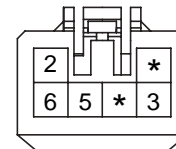

AMP_090III_06F_Y_S2

M36

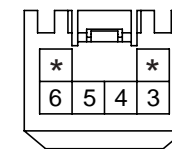

AMP_090III_06F_Y_2

ESP (ELECTRONIC STABILITY PROGRAM) SYSTEM

ESP (ELECTRONIC STABILITY PROGRAM) SYSTEM (4)

SD589-4

MEMO

POWER DOOR LOCKS (1)

SD813-1

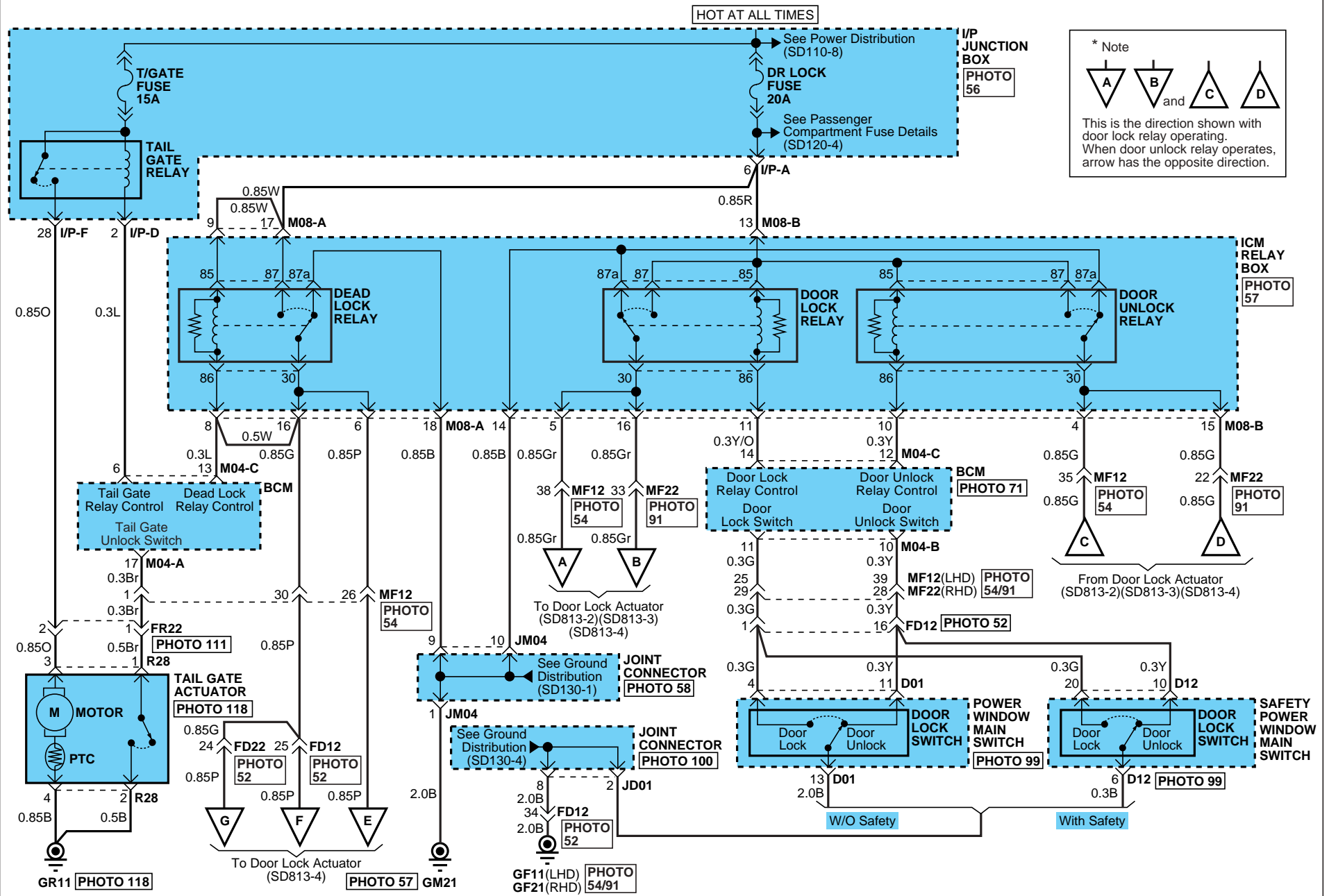

POWER DOOR LOCKS

POWER DOOR LOCKS (2)

SD813-2

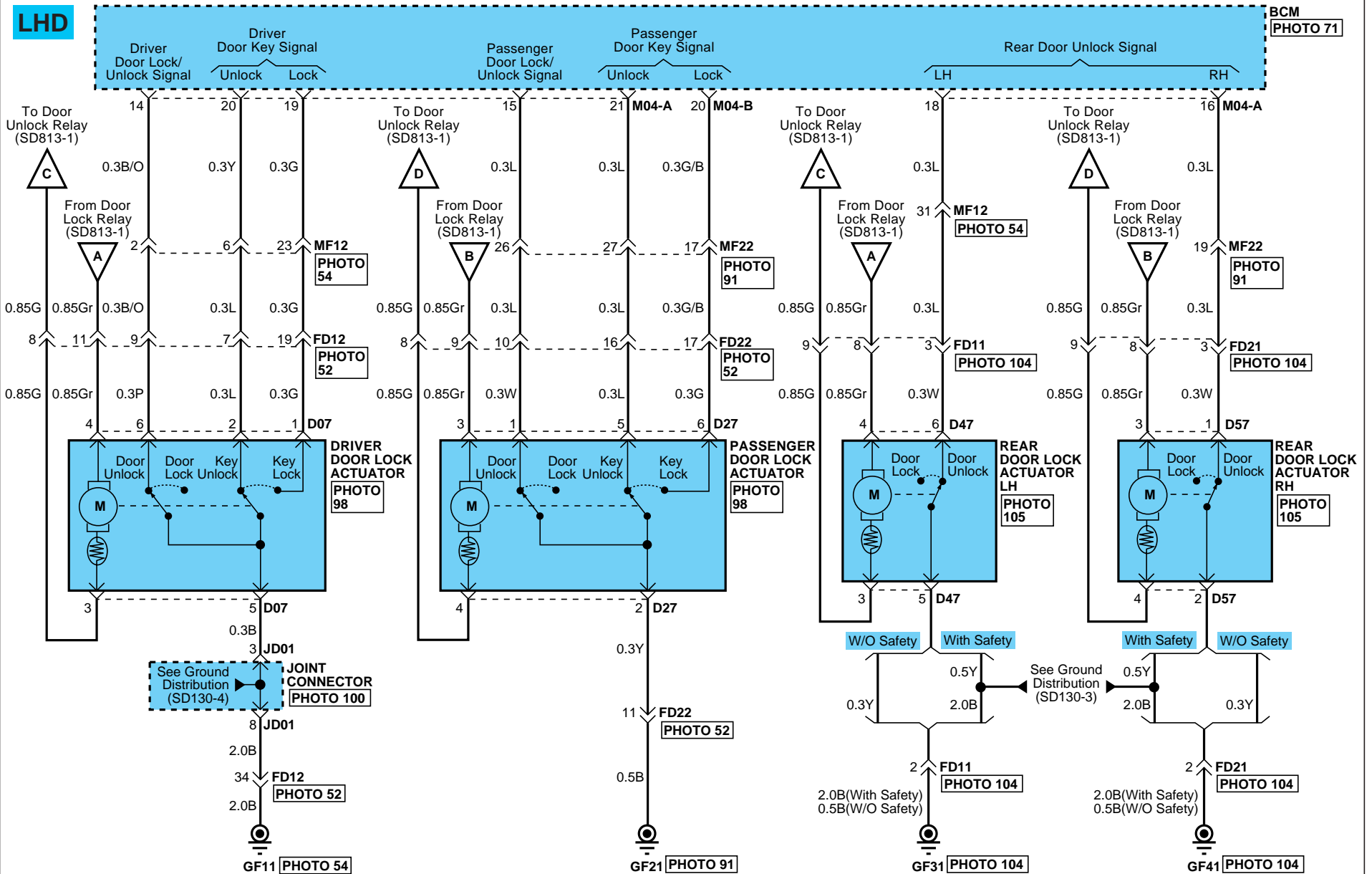

POWER DOOR LOCKS

POWER DOOR LOCKS (3)

SD813-3

RHD & W/O DEAD LOCK

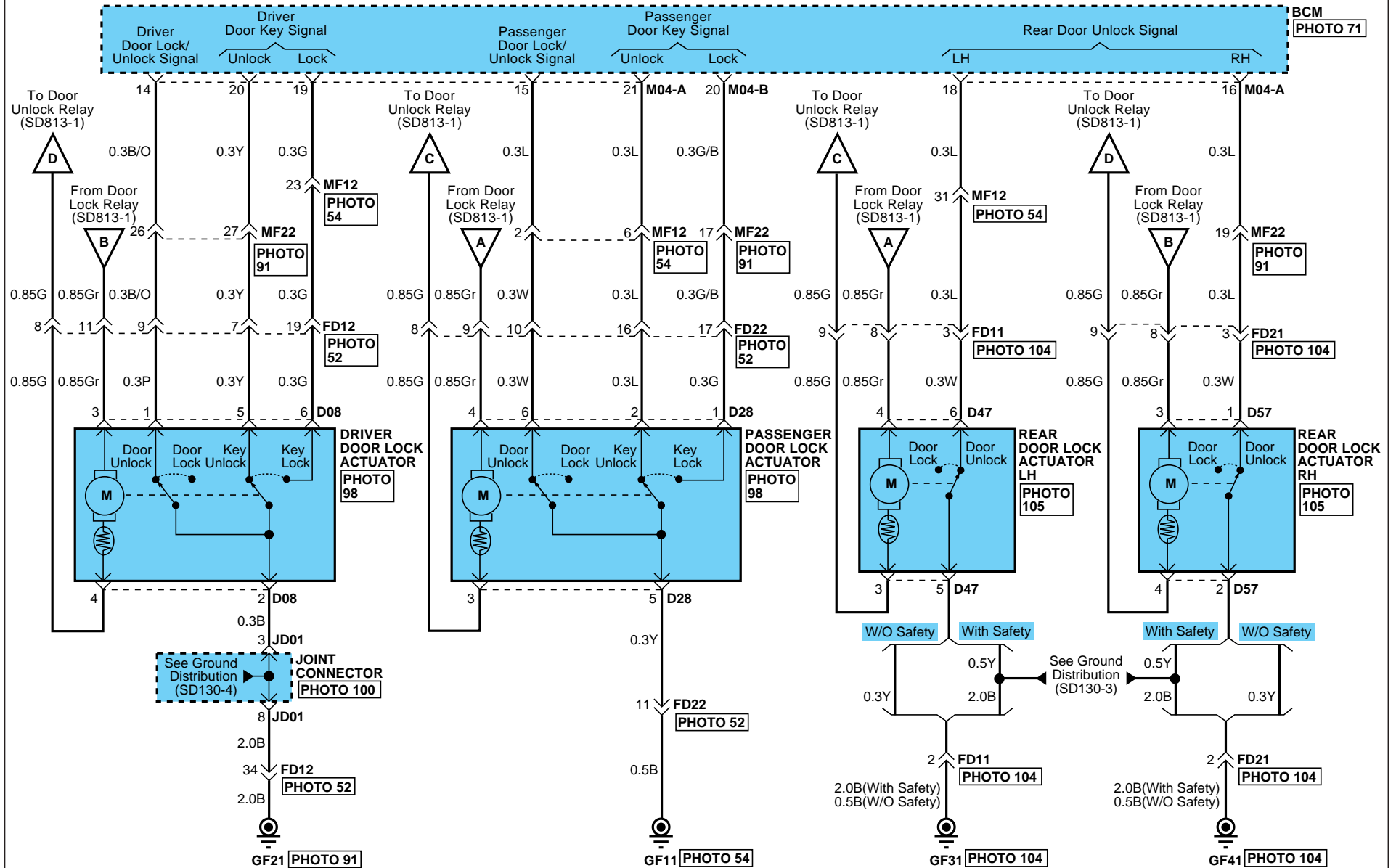

POWER DOOR LOCKS

POWER DOOR LOCKS (4)

SD813-4

RHD & With DEAD LOCK

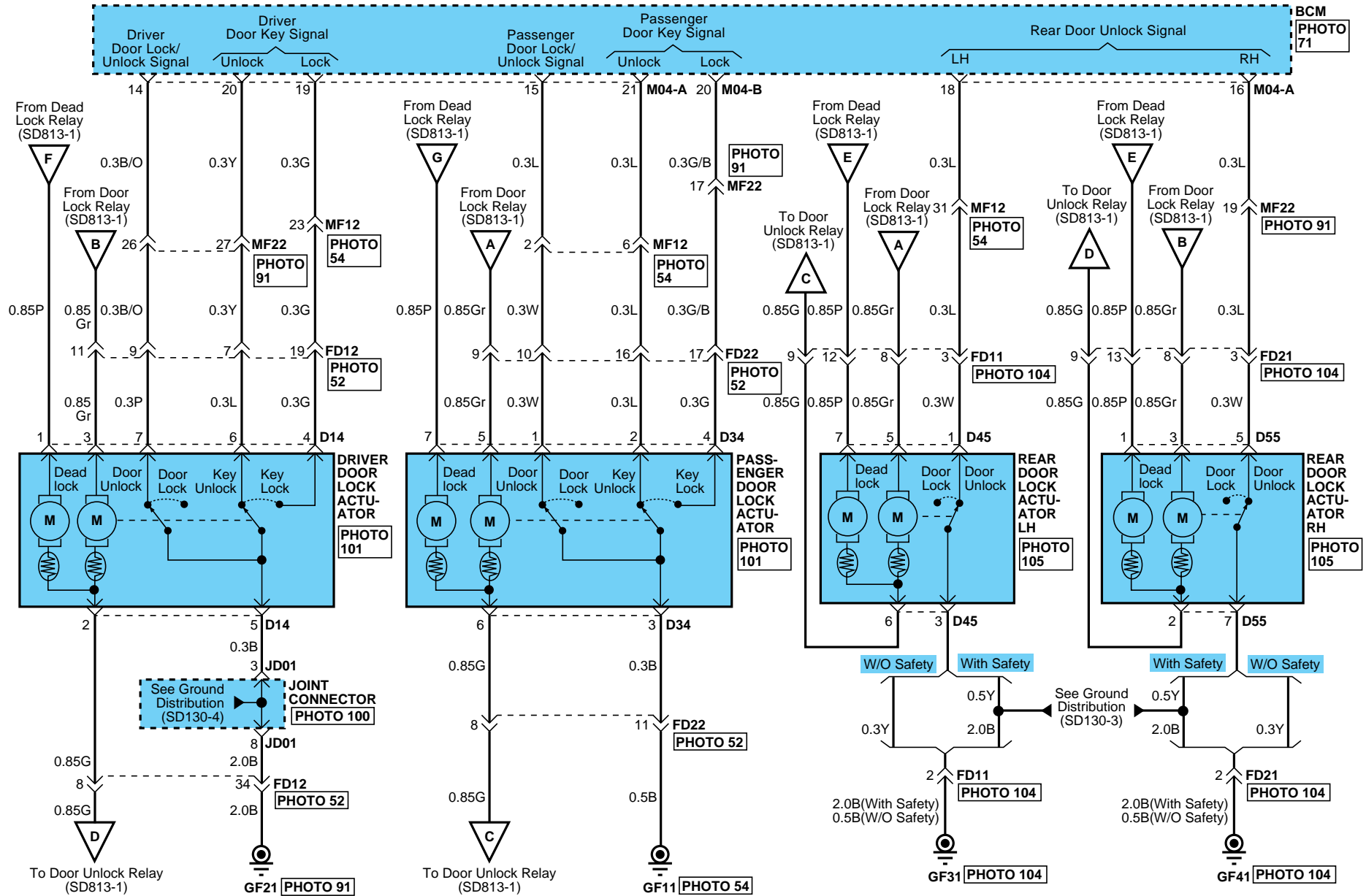

POWER DOOR LOCKS

POWER DOOR LOCKS (5)

SD813-5

D01

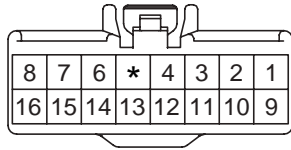

KET_090III_16F_W

D07

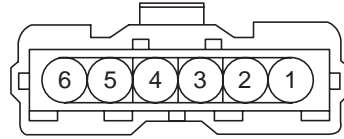

FCL_SENSOR_06F_B

D08

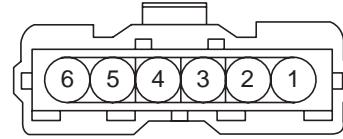

FCL_SENSOR_06F_B

D12

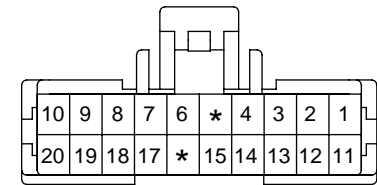

KET_SP_20F_W

D14

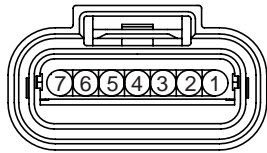

AMP_025WP_07F_B

D27

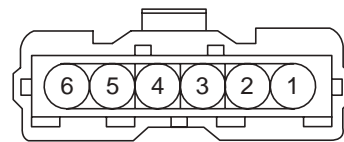

FCL_SENSOR_06F_B

D28

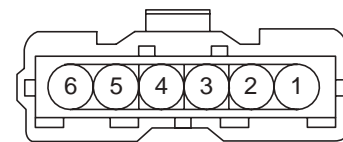

FCL_SENSOR_06F_B

D34

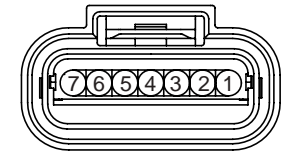

AMP_025WP_07F_B

D45

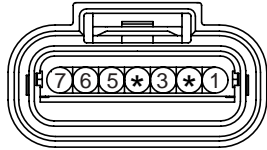

AMP_025WP_07F_B

D47

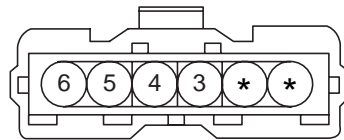

FCL_SENSOR_06F_B

D55

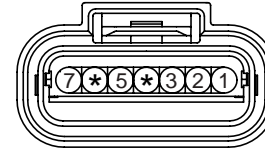

AMP_025WP_07F_B

D57

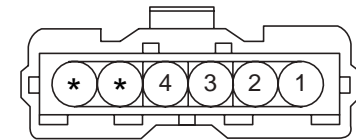

FCL_SENSOR_06F_B

M04-A

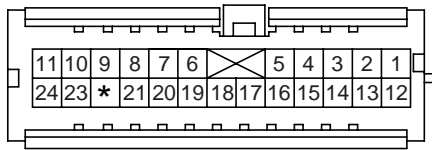

AMP_040III_24F_W

M04-B

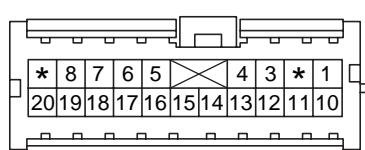

AMP_040III_20F_W

M04-C

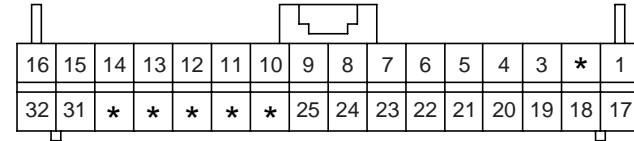

AMP_025_32F_W

M08-A

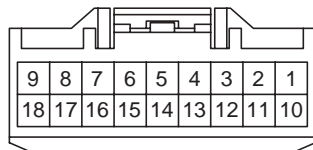

AMP_090III_18F_W

M08-B

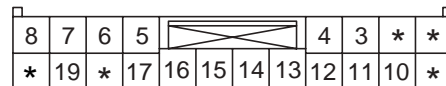

AMP_0925_20F_W

R28

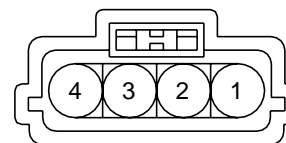

KUM_NDWP_04F_B

BLANK

POWER DOOR LOCKS

POWER DOOR LOCKS (6)

SD813-6

MEMO

KEYLESS ENTRY & BURGLAR ALARM SYSTEM (1)

SD814-1

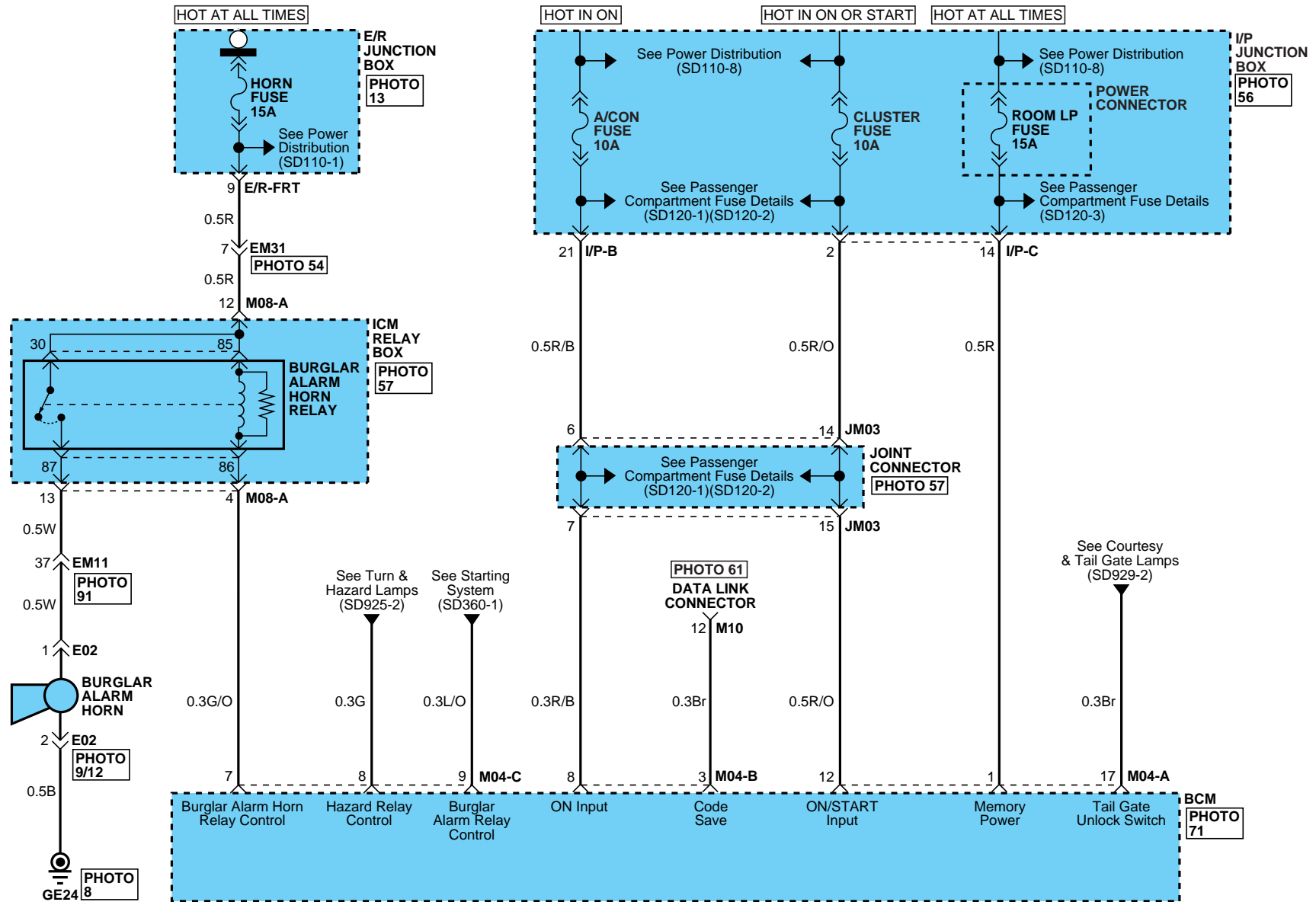

KEYLESS ENTRY & BURGLAR ALARM SYSTEM

KEYLESS ENTRY & BURGLAR ALARM SYSTEM (2)

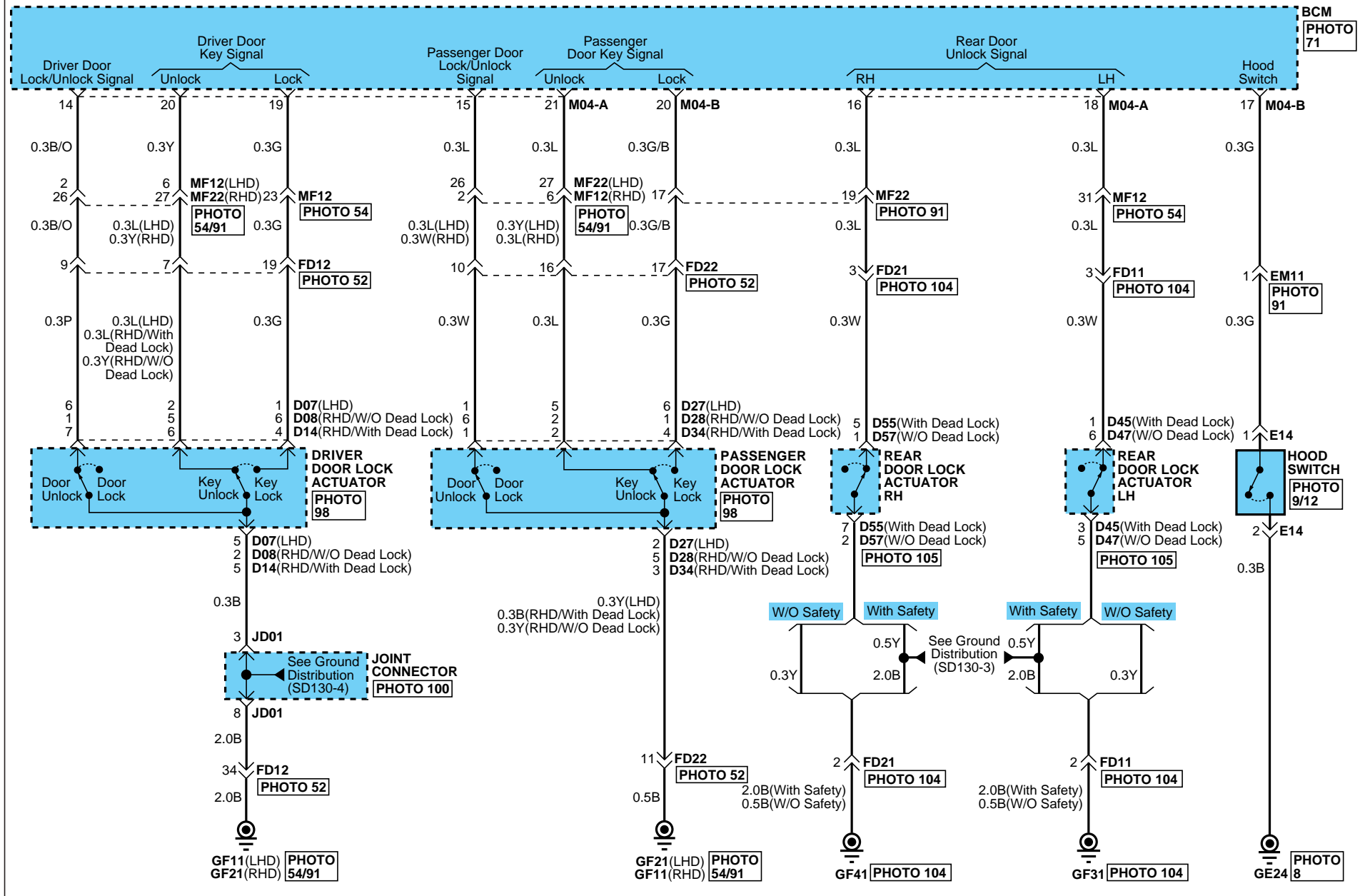

SD814-2



KEYLESS ENTRY & BURGLAR ALARM SYSTEM

KEYLESS ENTRY & BURGLAR ALARM SYSTEM (3)

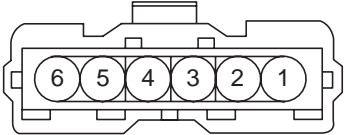
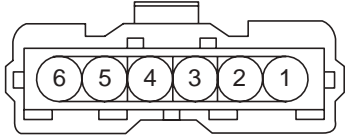
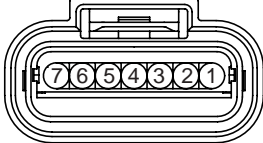
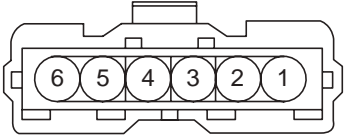
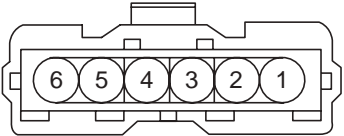
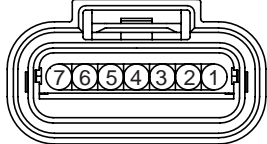
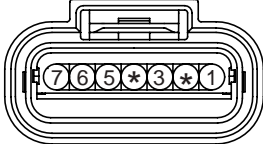
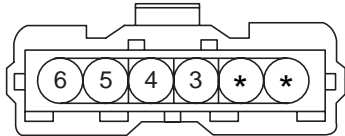
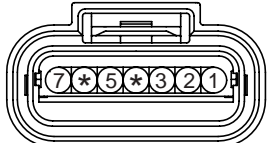
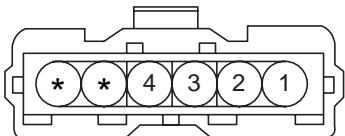
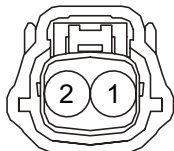
SD814-3

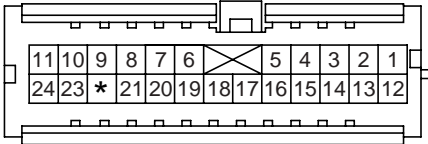
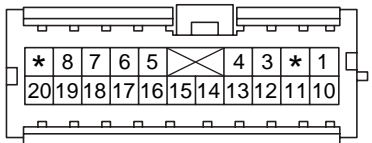
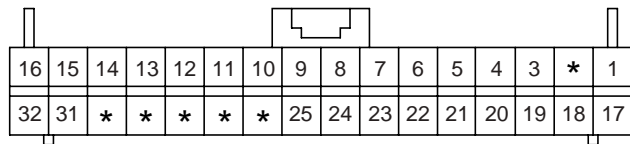
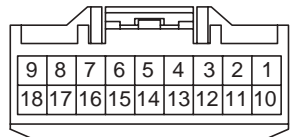
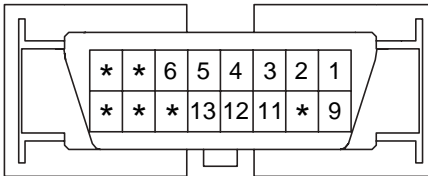
<p>D07</p>  <p>FCI_SENSOR_06F_B</p>	<p>D08</p>  <p>FCI_SENSOR_06F_B</p>	<p>D14</p>  <p>AMP_025WP_07F_B</p>	<p>D27</p>  <p>FCI_SENSOR_06F_B</p>
<p>D28</p>  <p>FCI_SENSOR_06F_B</p>	<p>D34</p>  <p>AMP_025WP_07F_B</p>	<p>D45</p>  <p>AMP_025WP_07F_B</p>	<p>D47</p>  <p>FCI_SENSOR_06F_B</p>
<p>D55</p>  <p>AMP_025WP_07F_B</p>	<p>D57</p>  <p>FCI_SENSOR_06F_B</p>	<p>E02</p>  <p>MLX_HORN_02F_B_FILT</p>	<p>E14</p>  <p>KET_090IWP_02F_W_ASM</p>
<p>M04-A</p>  <p>AMP_040III_24F_W</p>	<p>M04-B</p>  <p>AMP_040III_20F_W</p>	<p>M04-C</p>  <p>AMP_025_32F_W</p>	
<p>M08-A</p>  <p>AMP_090III_18F_W</p>	<p>M10</p>  <p>MLX_OBDII_16F_B</p>	<p>BLANK</p>	<p>BLANK</p>

KEYLESS ENTRY & BURGLAR ALARM SYSTEM

KEYLESS ENTRY & BURGLAR ALARM SYSTEM (4)

SD814-4

MEMO

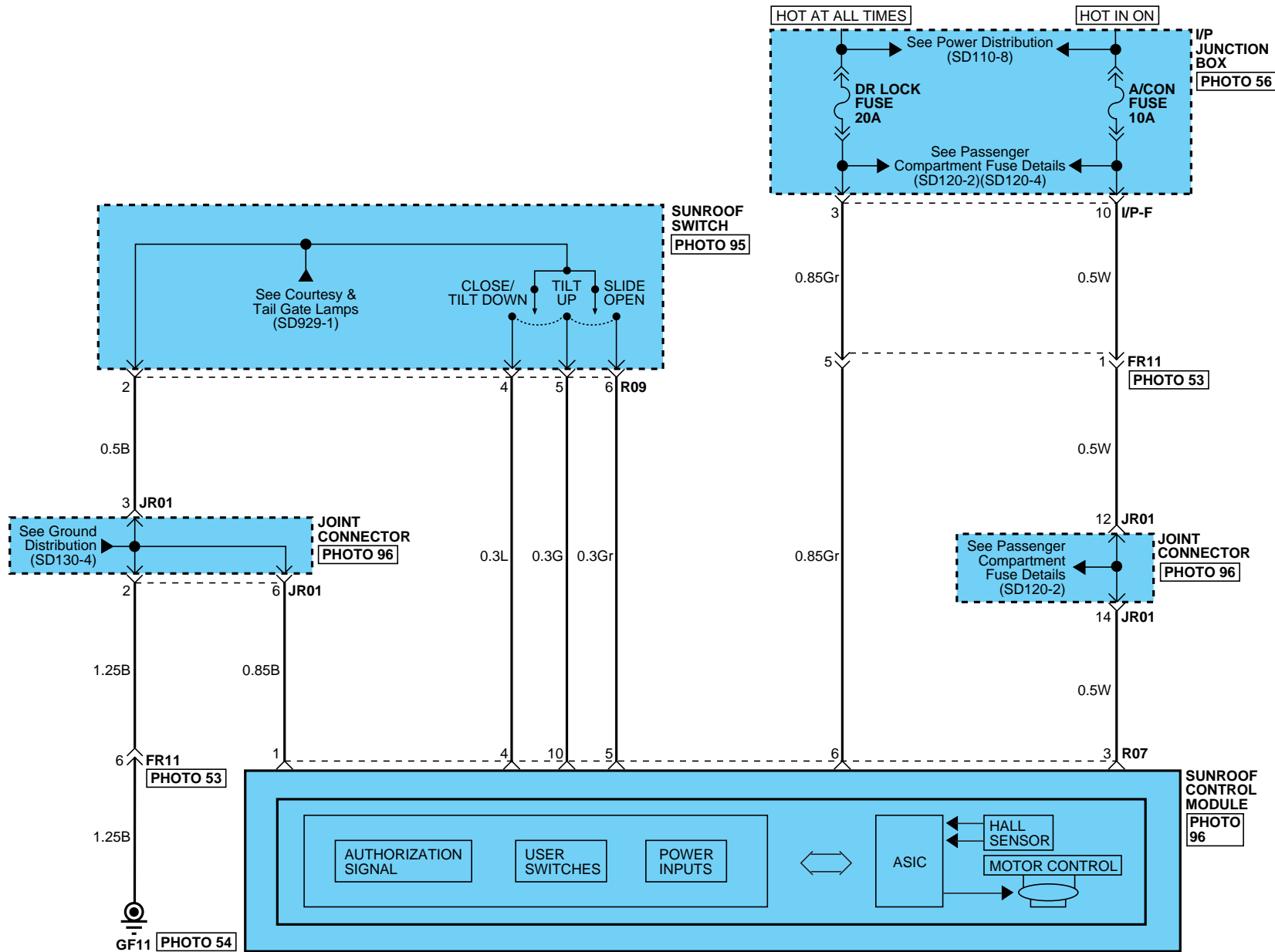

SUNROOF

SUNROOF (2)

SD816-2

R07

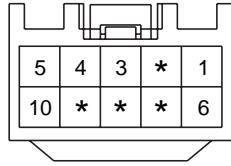

YAZ_1.5SYS_10F_Gr

R09

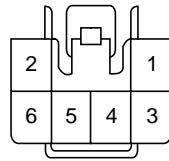

KET_090_06F_W

BLANK

BLANK

POWER WINDOWS (1)

SD824-1

HOT AT ALL TIMES

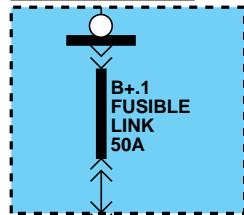

E/R JUNCTION BOX PHOTO 13

With Safety Power Window

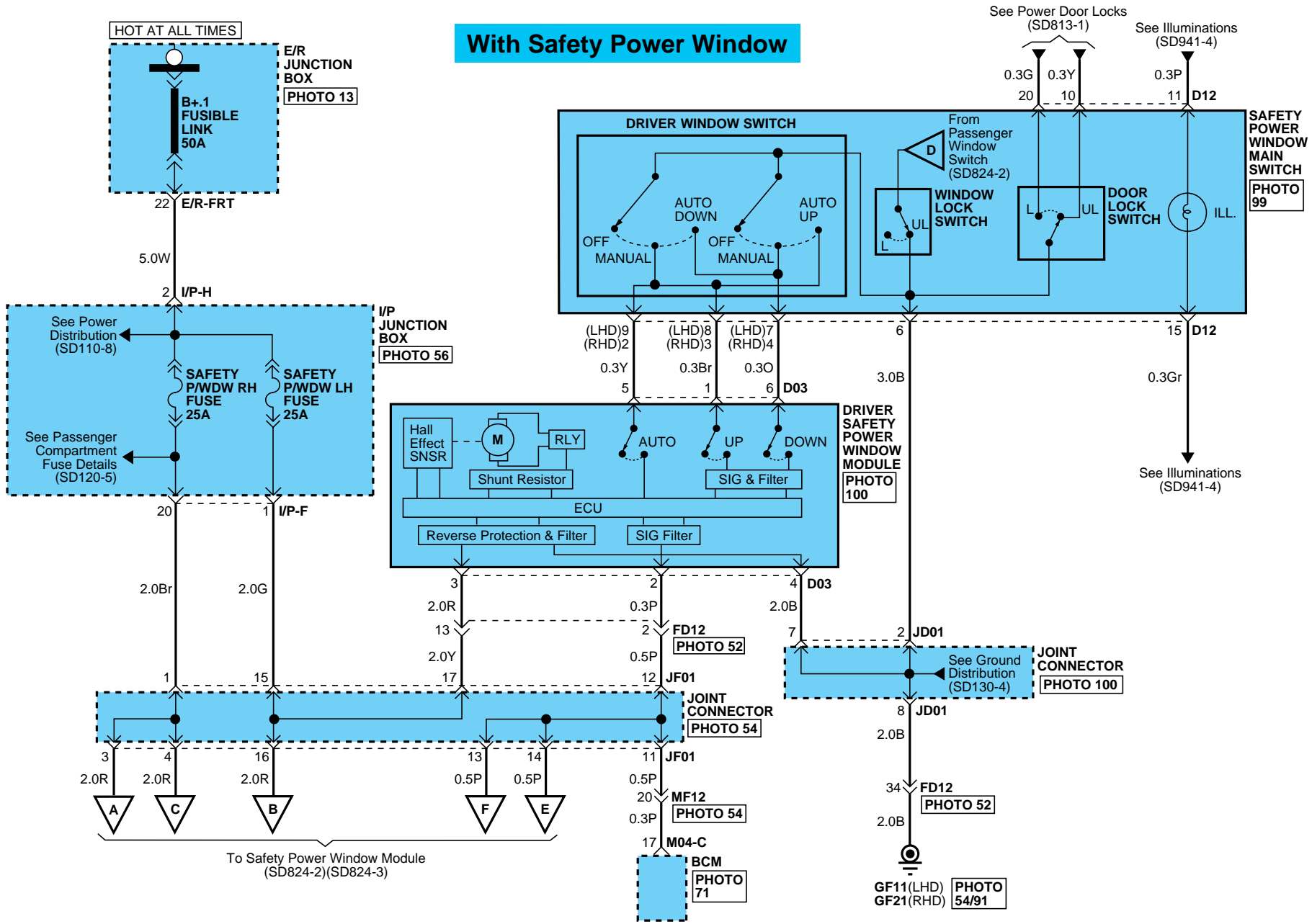

To Safety Power Window Module (SD824-2)(SD824-3)

POWER WINDOWS

POWER WINDOWS (2)

SD824-2

With Safety Power Window

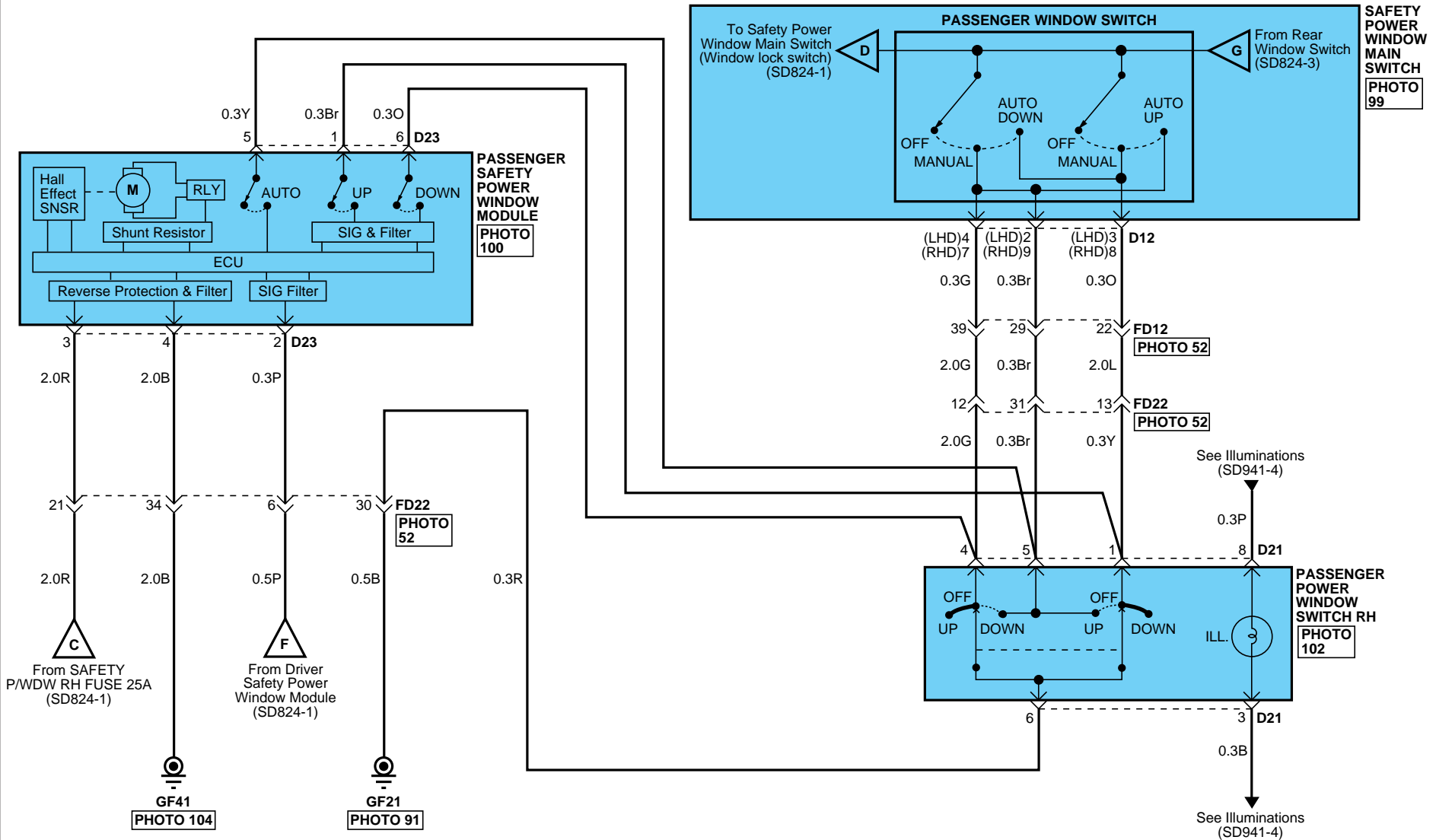

POWER WINDOWS

POWER WINDOWS (3)

SD824-3

With Safety Power Window

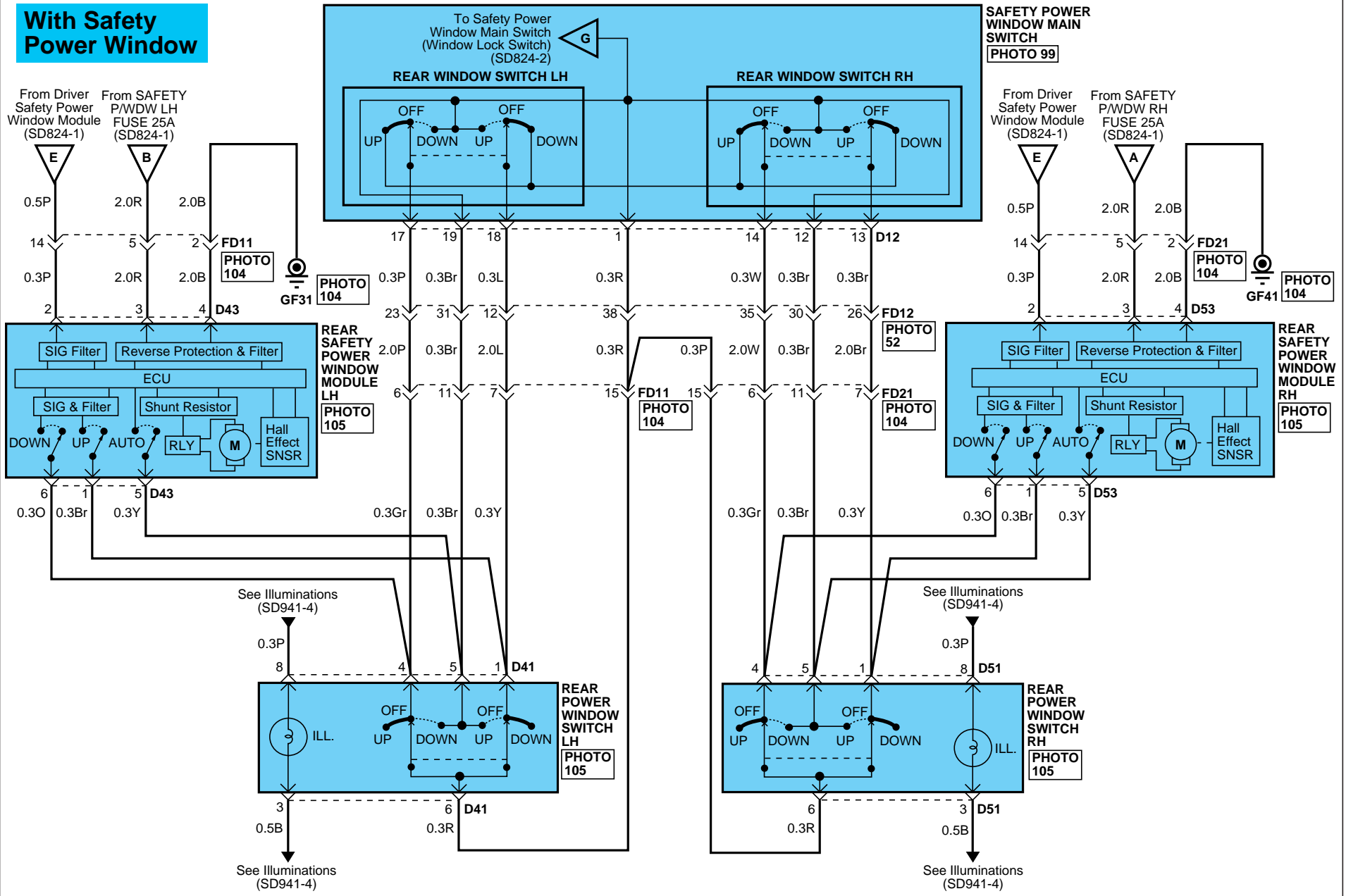

W/O Safety Power Window (Front & Rear)

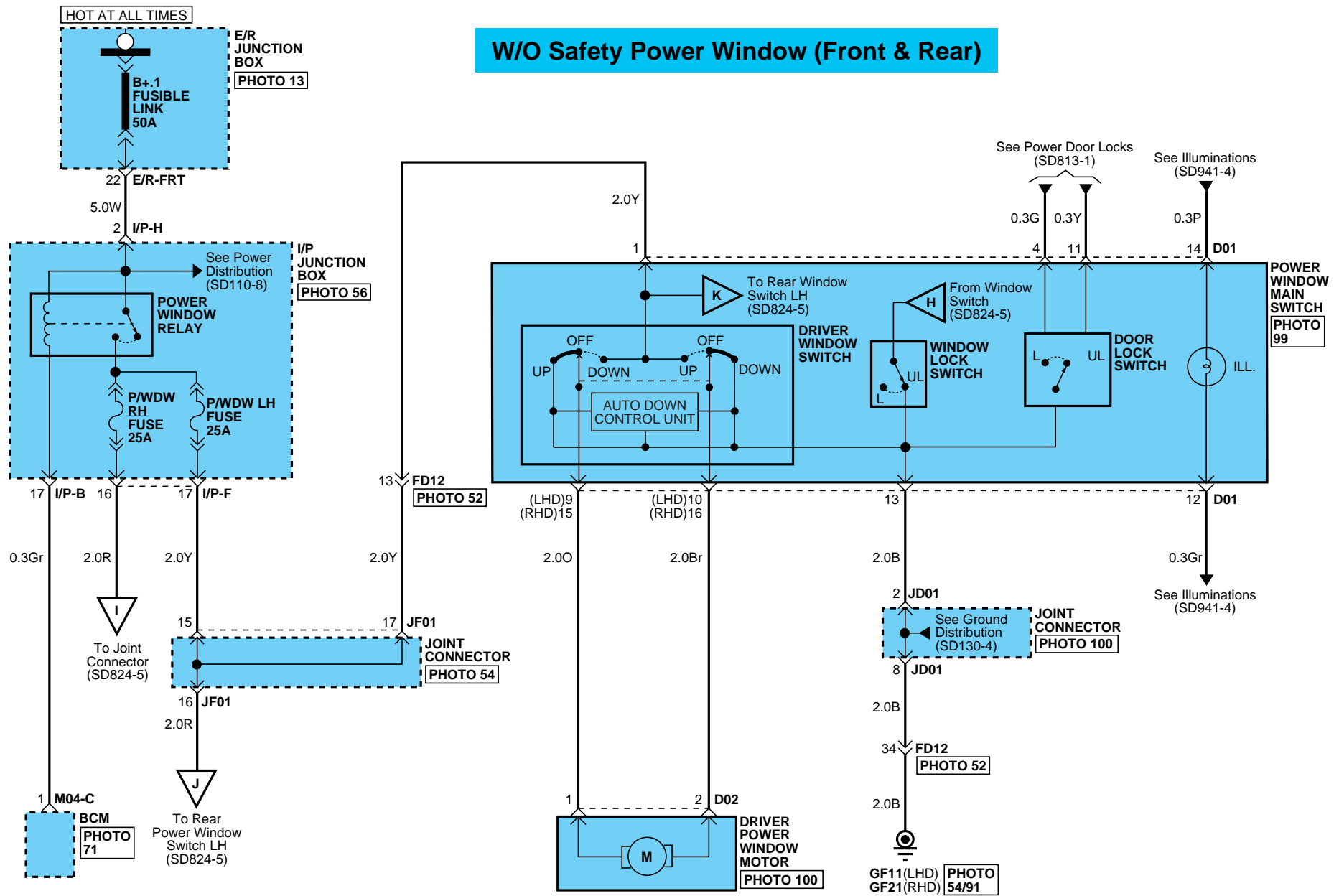

POWER WINDOWS

POWER WINDOWS (5)

SD824-5

W/O Safety Power Window (Front & Rear)

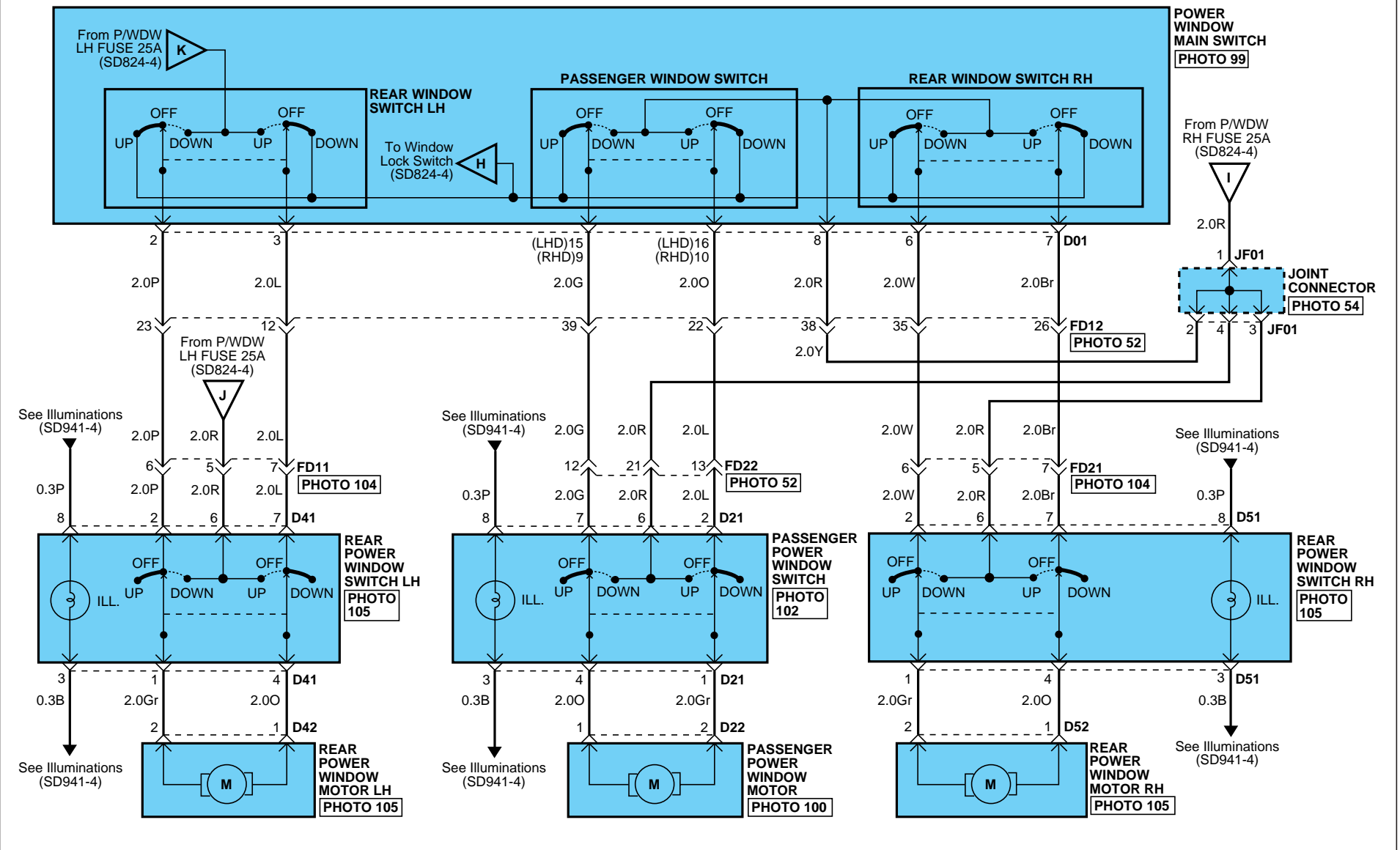

POWER WINDOWS

POWER WINDOWS (6)

SD824-6

W/O Safety Power Window (Front)

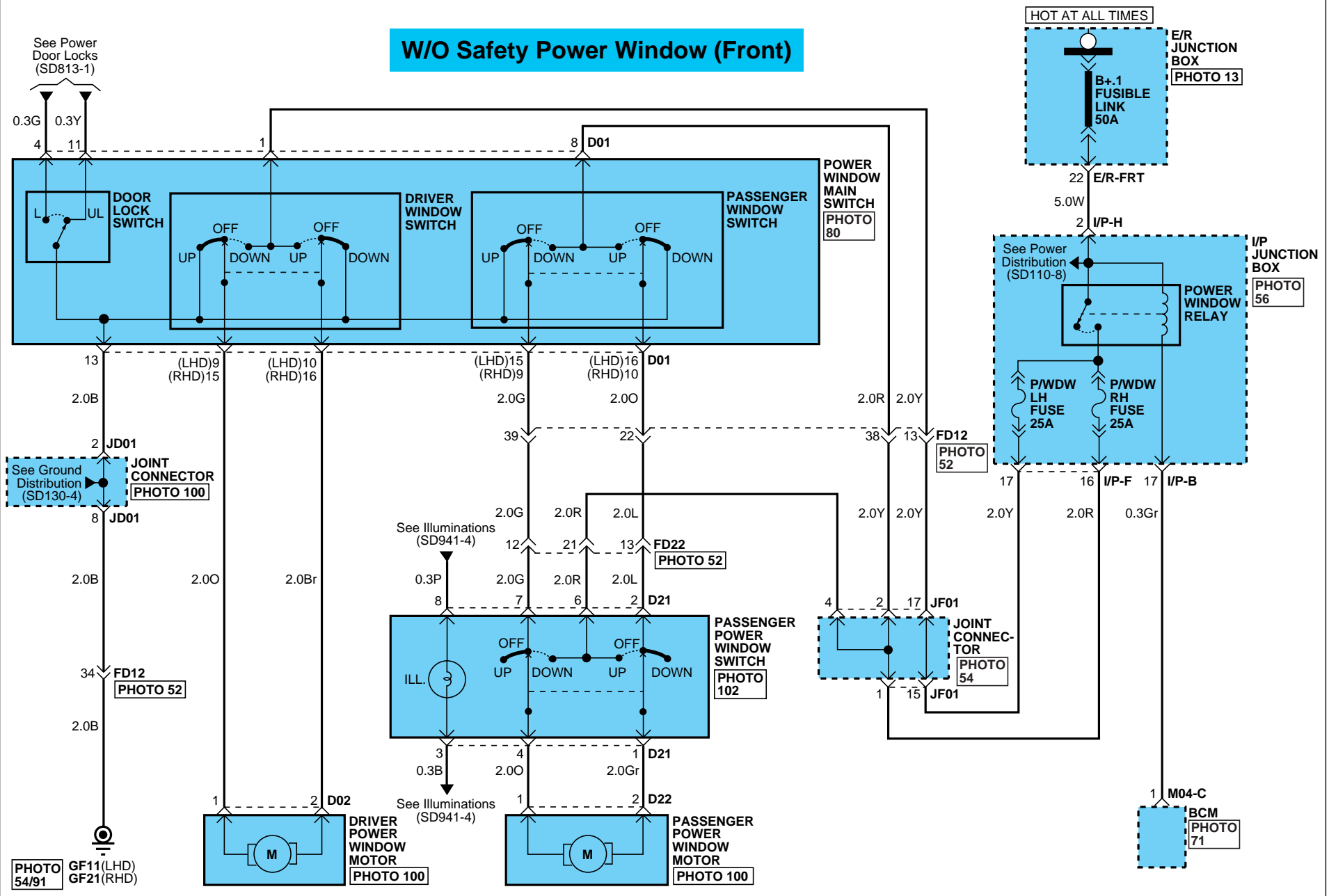

POWER WINDOWS

POWER WINDOWS (7)

SD824-7

D01

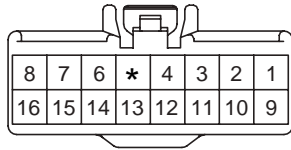

KET_090III_16F_W

D02

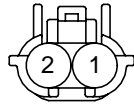

KET_SWP_02F_B

D03

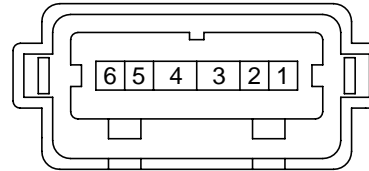

FCI_MINIWP_06F_B_SL

D12

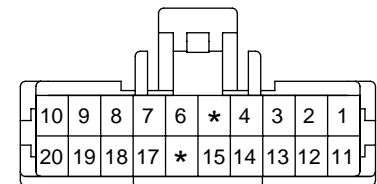

KET_SP_02F_W

D21

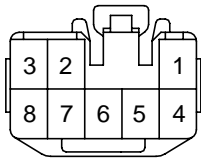

KET_090II_08F_W

D22

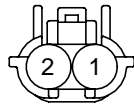

KET_SWP_02F_B

D23

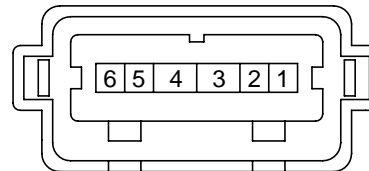

FCI_MINIWP_06F_B_SL

D41

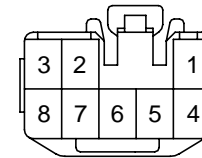

KET_090II_08F_W

D42

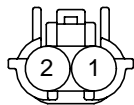

KET_SWP_02F_B

D43

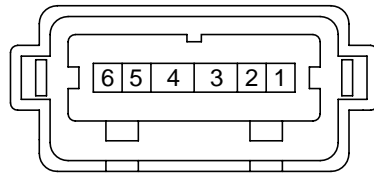

FCI_MINIWP_06F_B_SL

D51

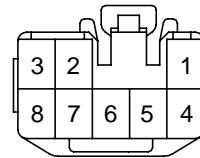

KET_090II_08F_W

D52

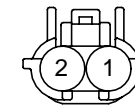

KET_SWP_02F_B

D53

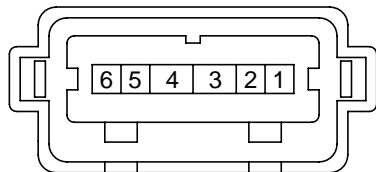

FCI_MINIWP_06F_B_SL

M04-C

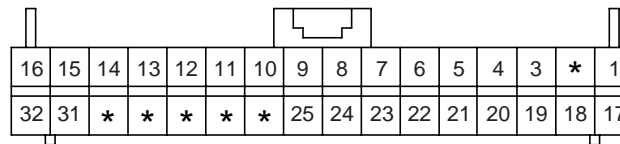

AMP_025_32F_W

BLANK

POWER WINDOWS

POWER WINDOWS (8)

SD824-8

MEMO

ELECTRO CHROMIC MIRROR (1)

SD851-1

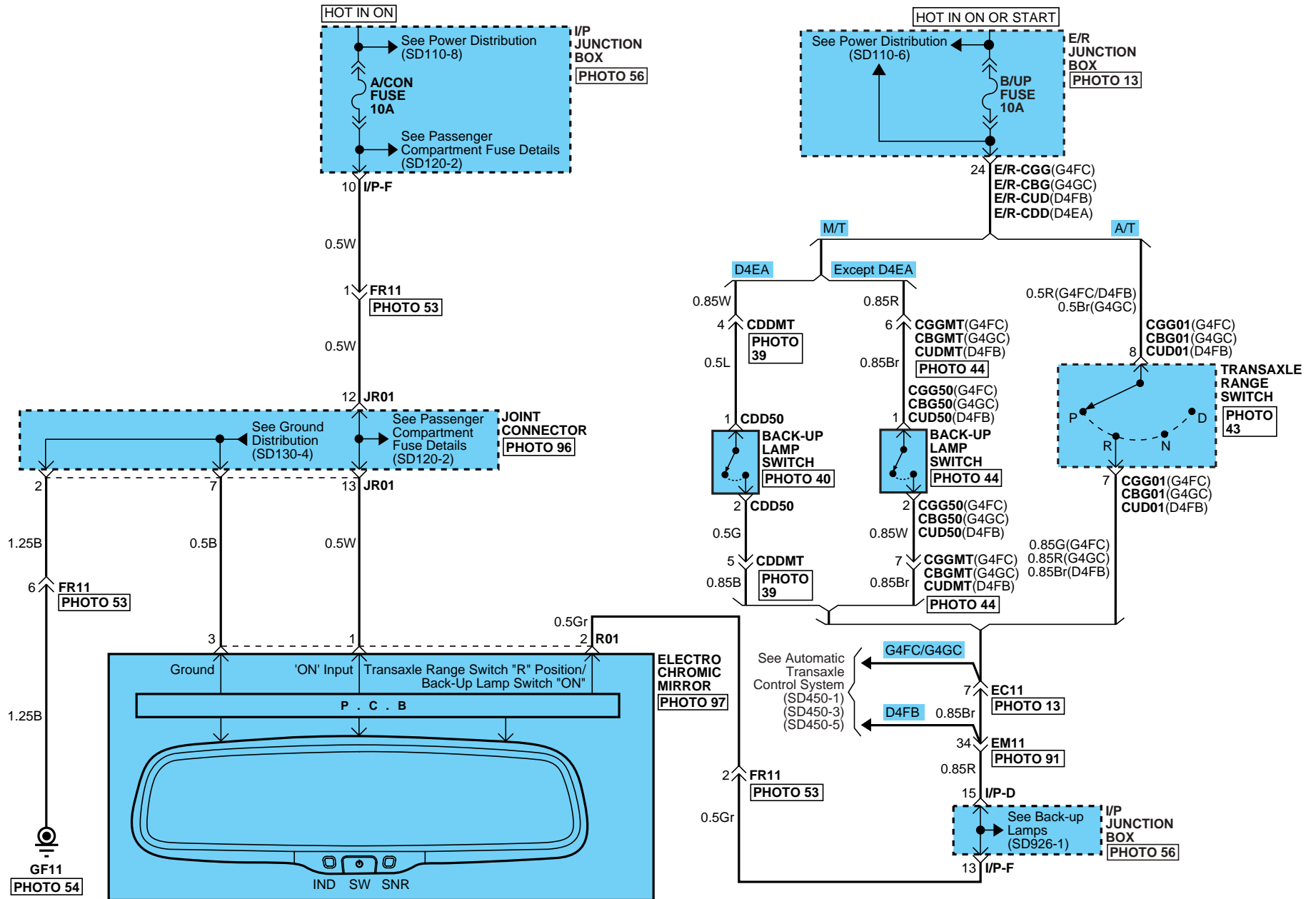

ELECTRO CHROMIC MIRROR

ELECTRO CHROMIC MIRROR (2)

SD851-2

CGG01



KET_SSD_10F_B_A

CGG50

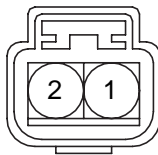

KUM_NMWP_02F_LGr

CBG01



KET_SSD_10F_B_A

CBG50

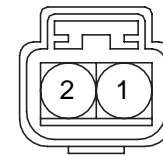

KUM_NMWP_02F_LGr

CUD01



KET_SSD_10F_B_A

CUD50

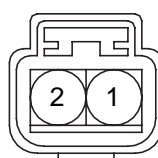

KUM_NMWP_02F_LGr

CDD50

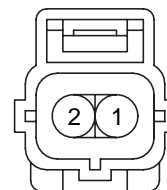

AMP_EJ_MK_II_2F

R01

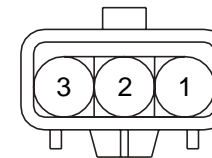

KET_TLCWP_03F_W

WINDSHIELD DEFOGGER SYSTEM (1)

SD861-1

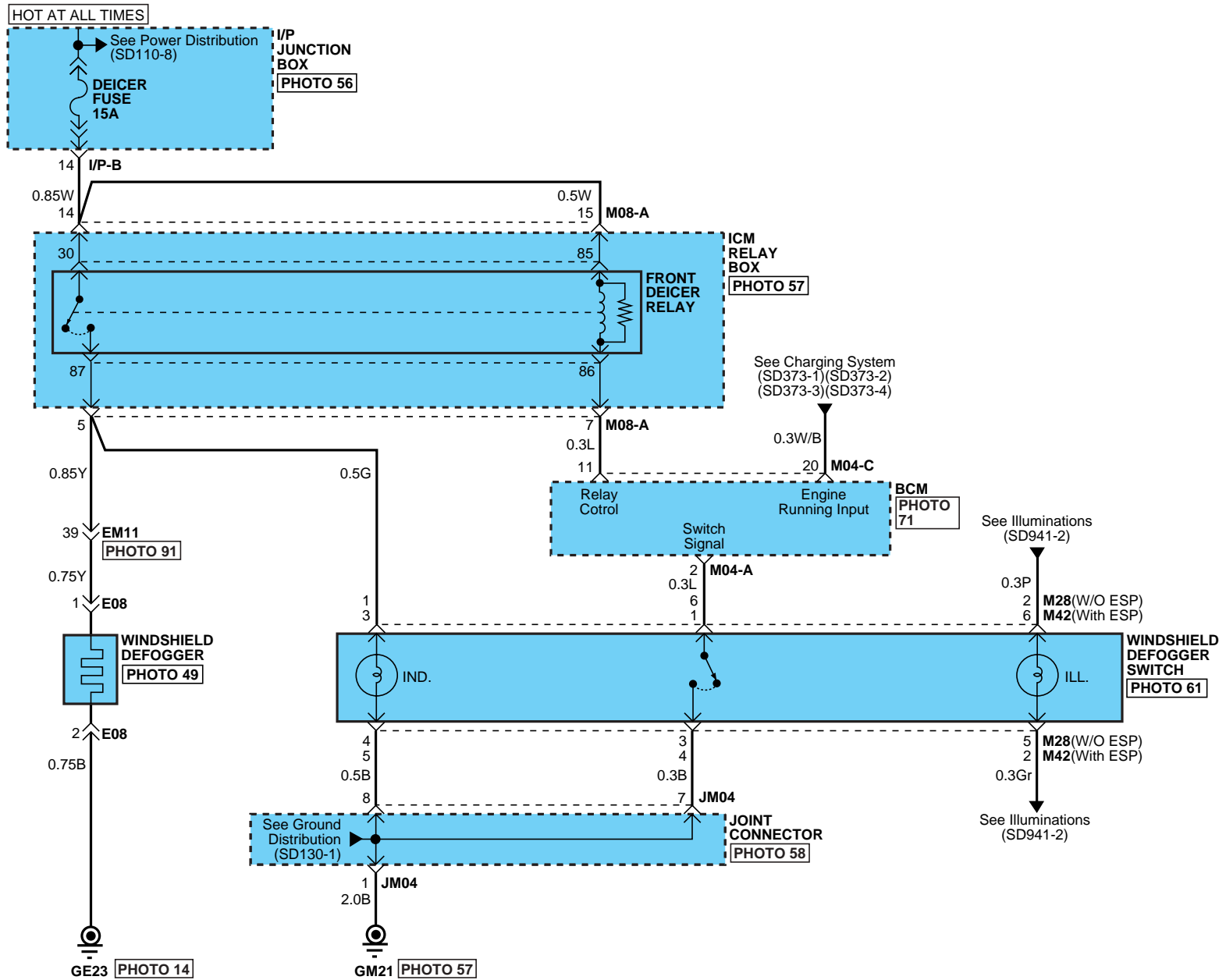

WINDSHIELD DEFOGGER SYSTEM

WINDSHIELD DEFOGGER SYSTEM (2)

SD861-2

E08

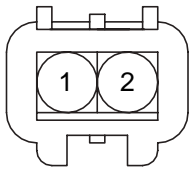

KUM_NMWP_02M_B

M04-A

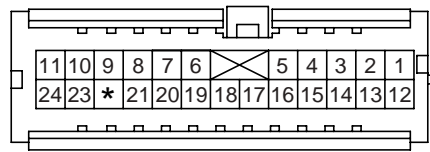

AMP_040III_24F_W

M04-C

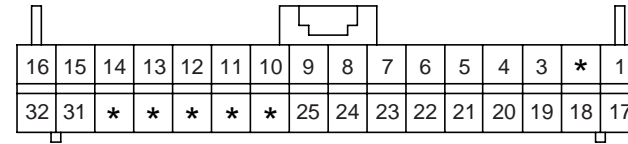

AMP_025_32F_W

M08-A

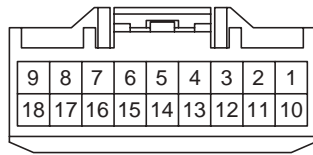

AMP_090III_18F_W

M28

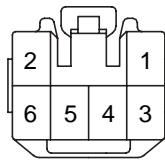

KET_090II_06F_L

M42

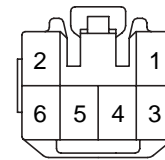

KET_090II_06F_L

BLANK

POWER OUTSIDE MIRRORS (1)

SD876-1

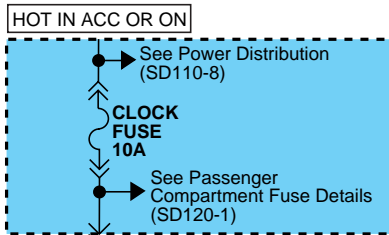

I/P JUNCTION BOX
[PHOTO 56]

TABLE

MIRROR SELECT SWITCH	SELECTOR SWITCH POSITION	POSITION	PIN NO.(RHD)								
			6 (6)	5 (5)	8 (12)	9 (11)	10 (10)	11 (9)	12 (8)		
DRIVER	UP		○	○	○	○					
	DOWN		○	○	○	○					
	OFF				○	○	○	○			
PASSENGER	UP		○	○	○	○					
	DOWN		○	○	○	○					
	OFF				○	○	○	○			
	LEFT		○		○						
	RIGHT		○		○						
	RIGHT		○		○						

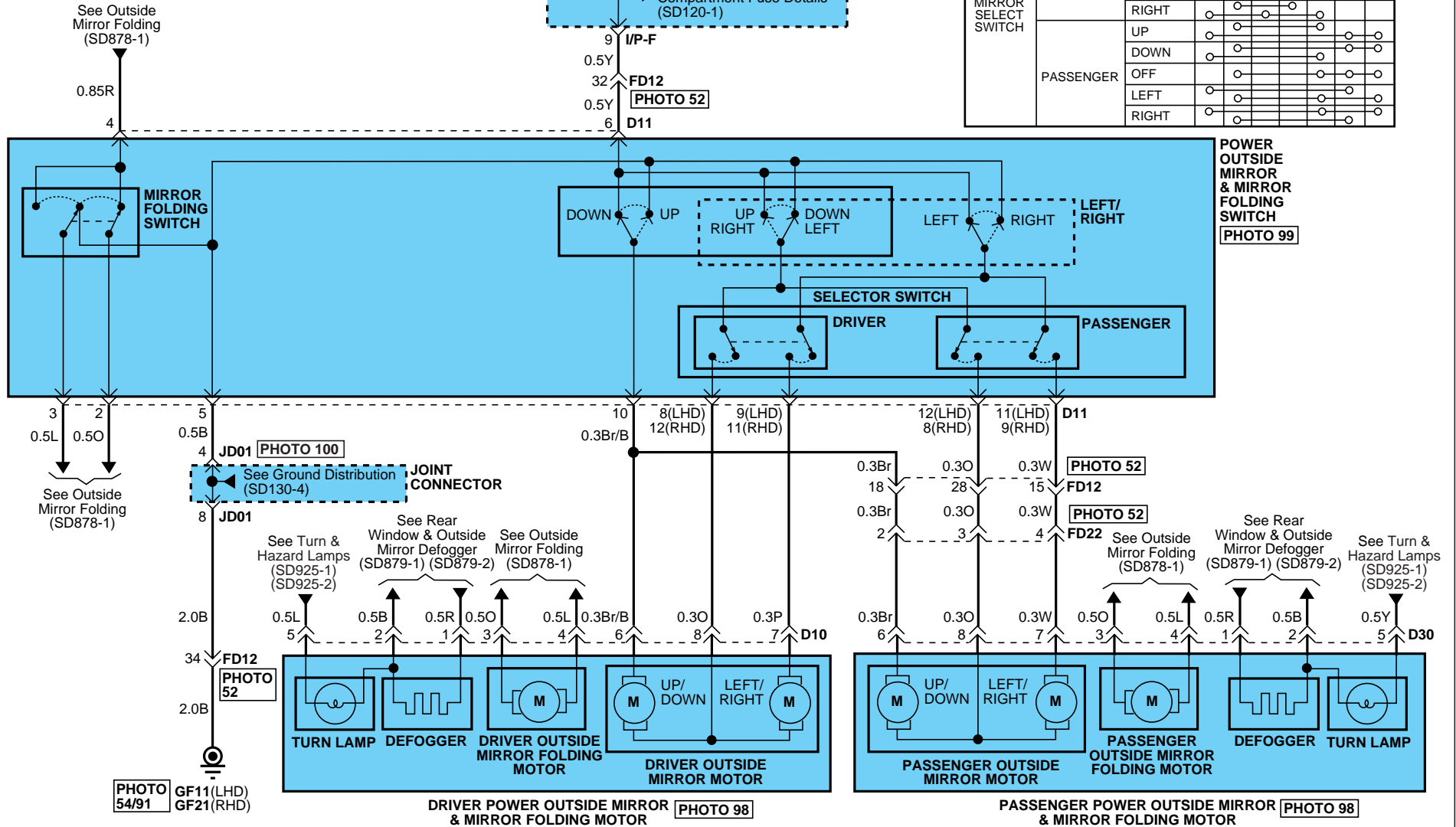

POWER OUTSIDE MIRROR & MIRROR FOLDING SWITCH
[PHOTO 99]

JOINT CONNECTOR
[PHOTO 100]

See Ground Distribution (SD130-4)

[PHOTO 54/91] GF11(LHD) GF21(RHD)

DRIVER POWER OUTSIDE MIRROR & MIRROR FOLDING MOTOR [PHOTO 98]

PASSENGER POWER OUTSIDE MIRROR & MIRROR FOLDING MOTOR [PHOTO 98]

POWER OUTSIDE MIRRORS

POWER OUTSIDE MIRRORS (2)

SD876-2

D10

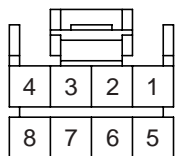

AMP_040M1_08F_B

D11

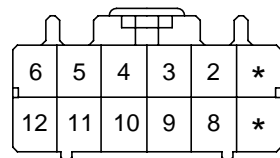

AMP_0407_12F_W_070

D30

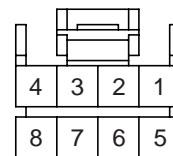

AMP_040M1_08F_B

BLANK

OUTSIDE MIRROR FOLDING (1)

SD878-1

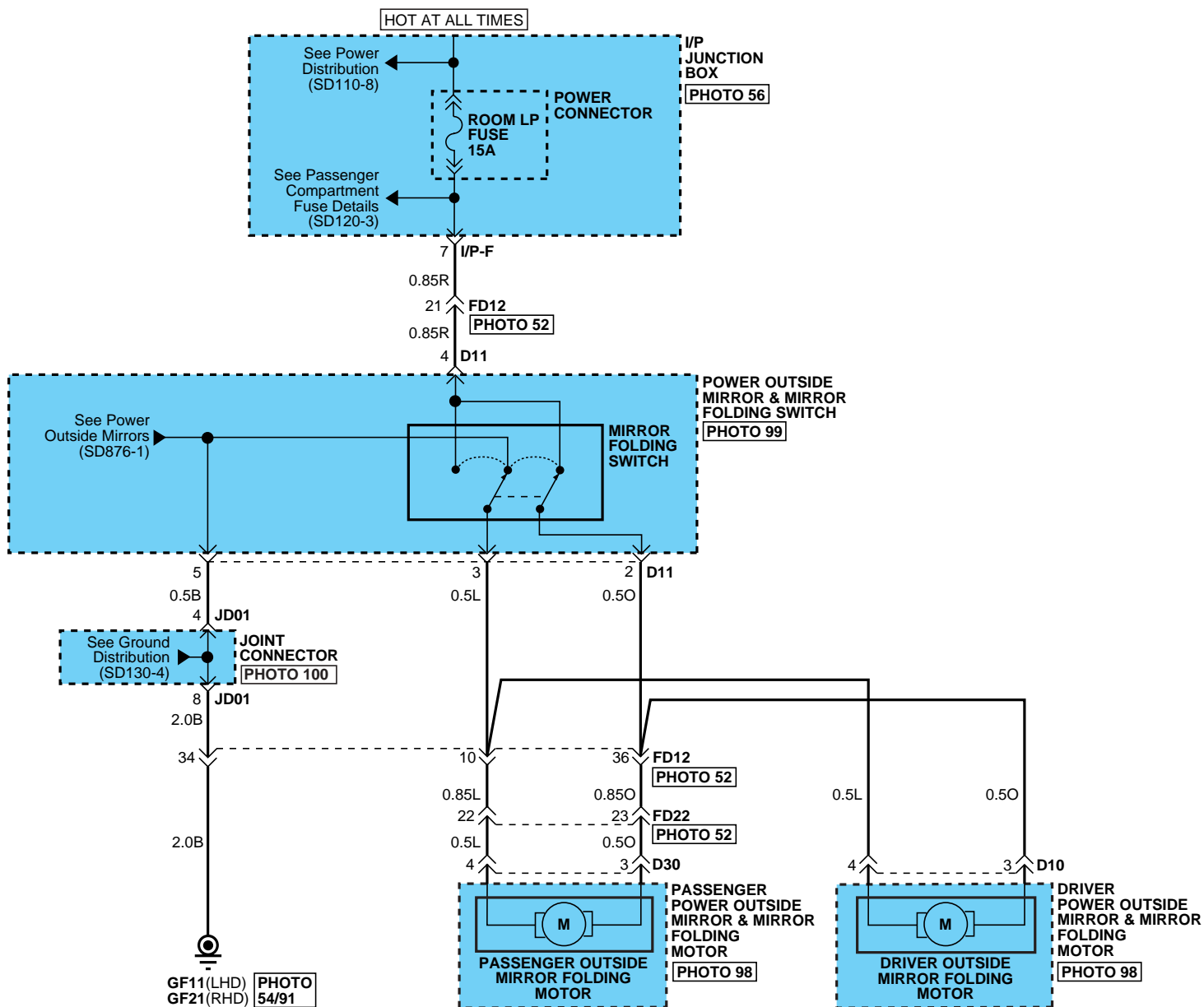

OUTSIDE MIRROR FOLDING

OUTSIDE MIRROR FOLDING (2)

SD878-2

D10

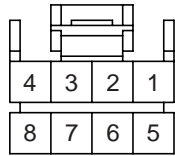

AMP_040M1_08F_B

D11

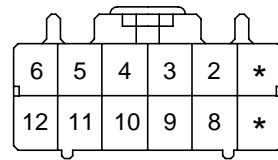

AMP_0407_12F_W_070

D30

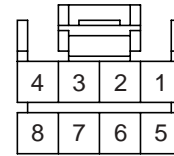

AMP_040M1_08F_B

BLANK

W/O EUROPE (AUTO A/C)

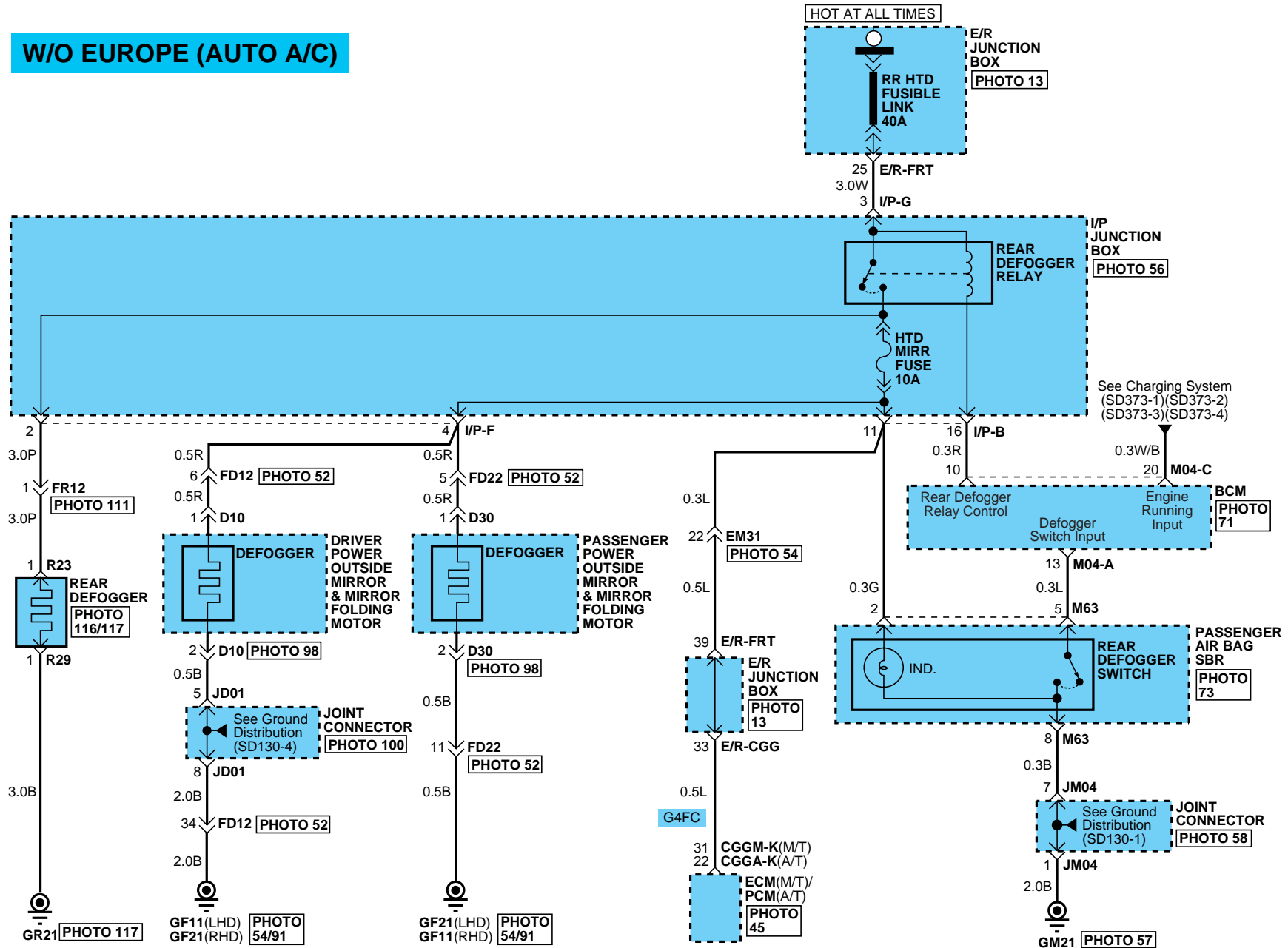

REAR WINDOW & OUTSIDE MIRROR DEFOGGER

REAR WINDOW & OUTSIDE MIRROR DEFOGGER (2)

SD879-2

With EUROPE (AUTO A/C) / MANUAL A/C

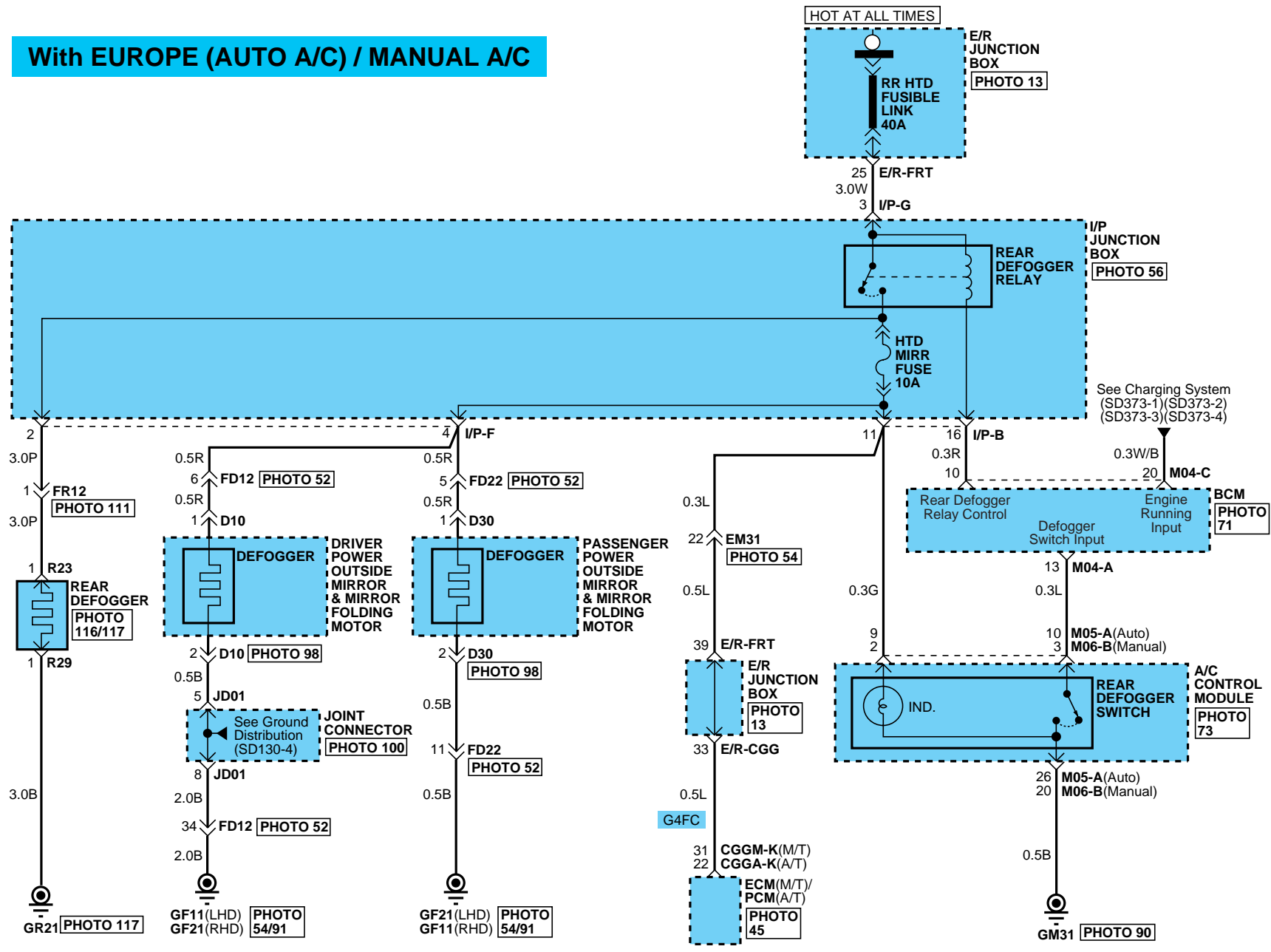

REAR WINDOW & OUTSIDE MIRROR DEFOGGER

REAR WINDOW & OUTSIDE MIRROR DEFOGGER (3)

SD879-3

CGGA-K

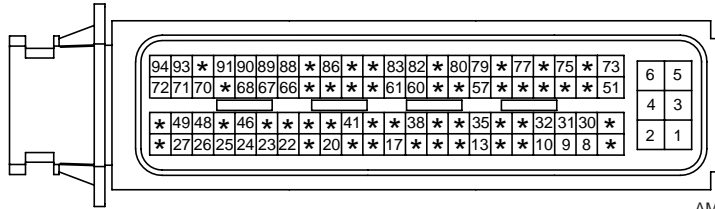

AMP_ECU_94F_B

CGGM-K

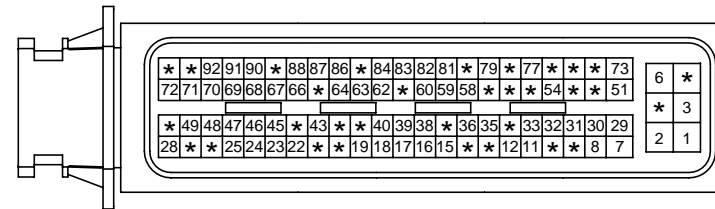

AMP_ECU_94F_B

D10

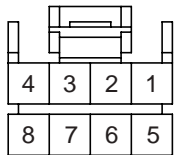

AMP_040M1_08F_B

D30

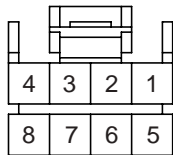

AMP_040M1_08F_B

M04-A

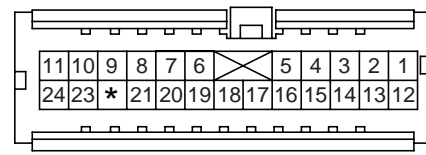

AMP_040III_24F_W

BLANK

M04-C

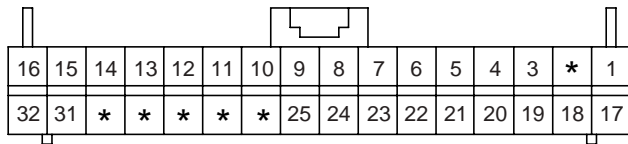

AMP_025_32F_W

M05-A

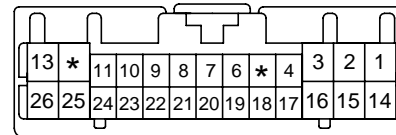

KET_0407_26F_W

BLANK

M06-B

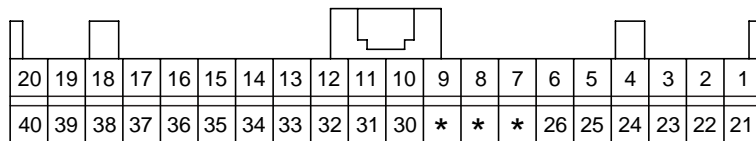

AMP_025_40F_W

M63

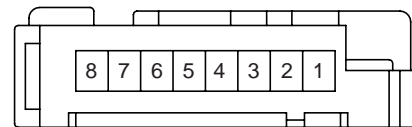

AMP_MQS_08F_W

R23



AMP_250DL_01F_B

R29



AMP_250DL_01F_B

BLANK

BLANK

BLANK

REAR WINDOW & OUTSIDE MIRROR DEFOGGER

REAR WINDOW & OUTSIDE MIRROR DEFOGGER (4)

SD879-4

MEMO

SEAT BELT REMINDER (1)

SD888-3

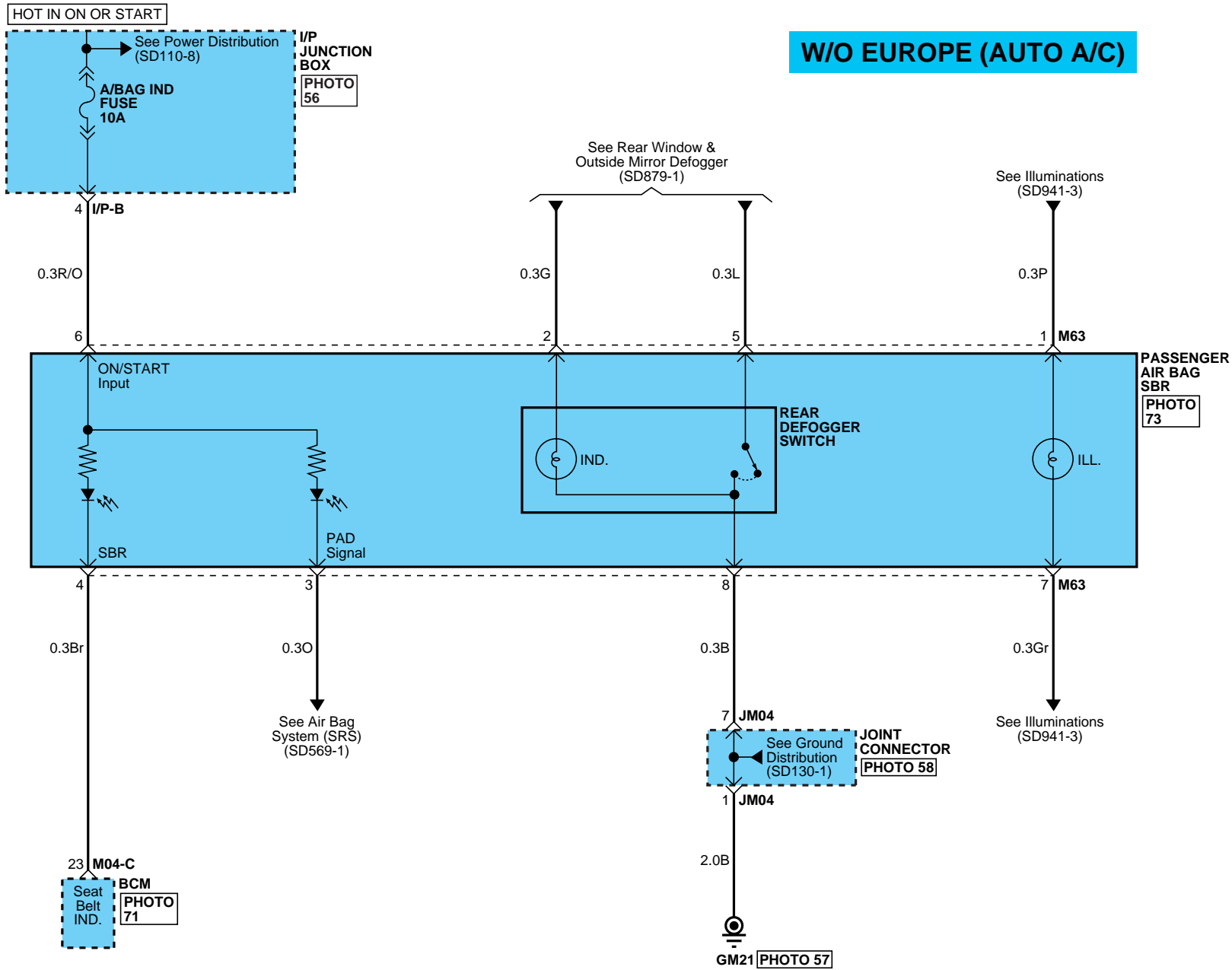

SEAT BELT REMINDER

SEAT BELT REMINDER (2)

SD888-4

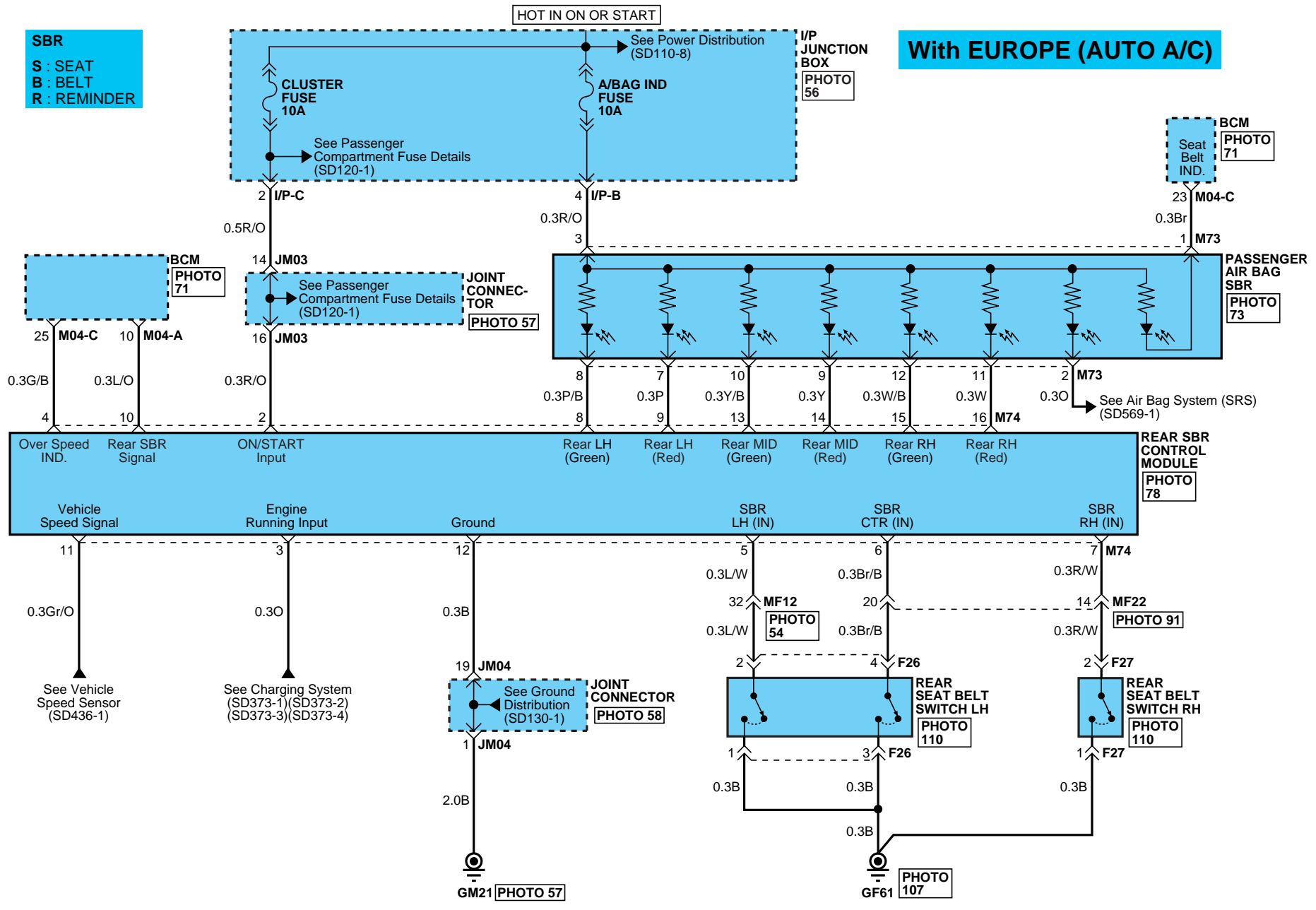

SEAT BELT REMINDER

SEAT BELT REMINDER (3)

SD888-5

SBR
S : SEAT
B : BELT
R : REMINDER

With EUROPE (MANUAL A/C)

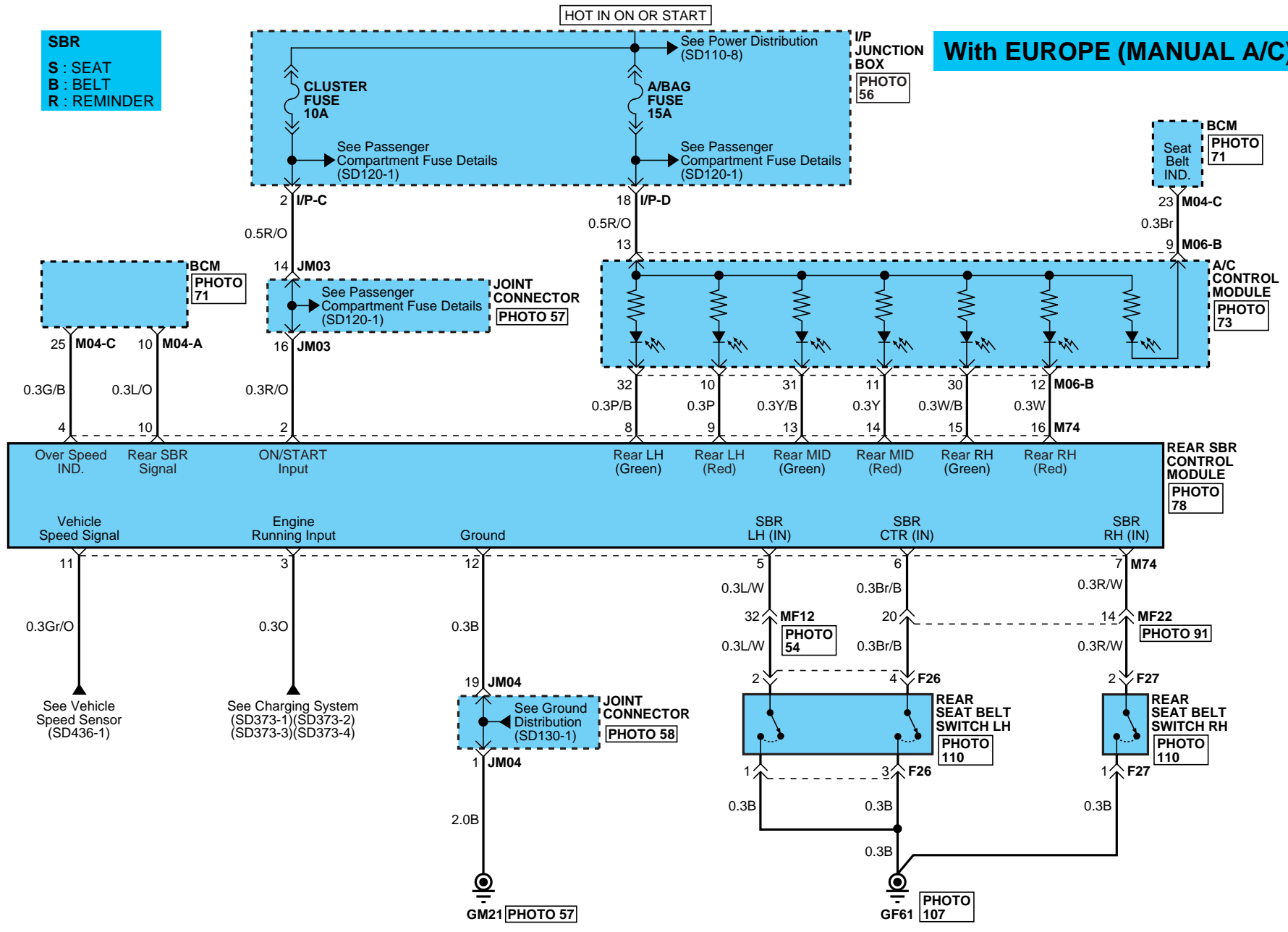

SEAT BELT REMINDER

SEAT BELT REMINDER (4)

SD888-6

F26

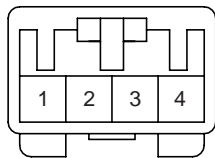

AMP_070_04M_W

F27

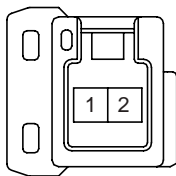

KET_040III_02M_W

M04-A

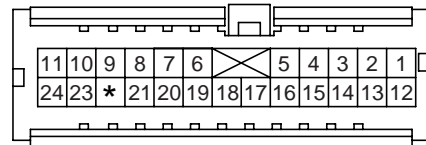

AMP_040III_24F_W

BLANK

M04-C

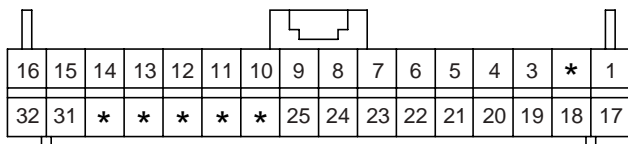

AMP_025_32F_W

M06-B

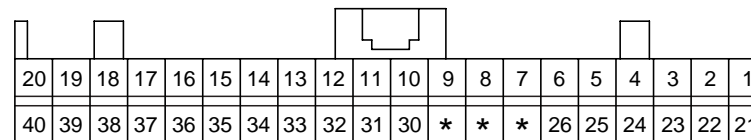

AMP_025_40F_W

M63

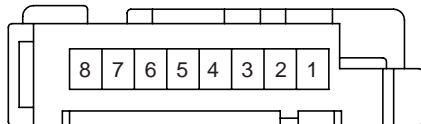

AMP_MQS_08F_W

M73

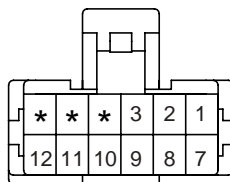

KET_SP_12F_B

M74

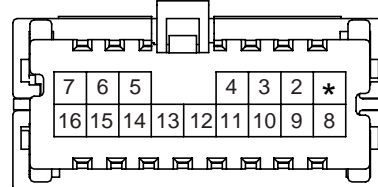

KET_040III_16F_W

BLANK

SEAT WARMER (1)

SD889-1

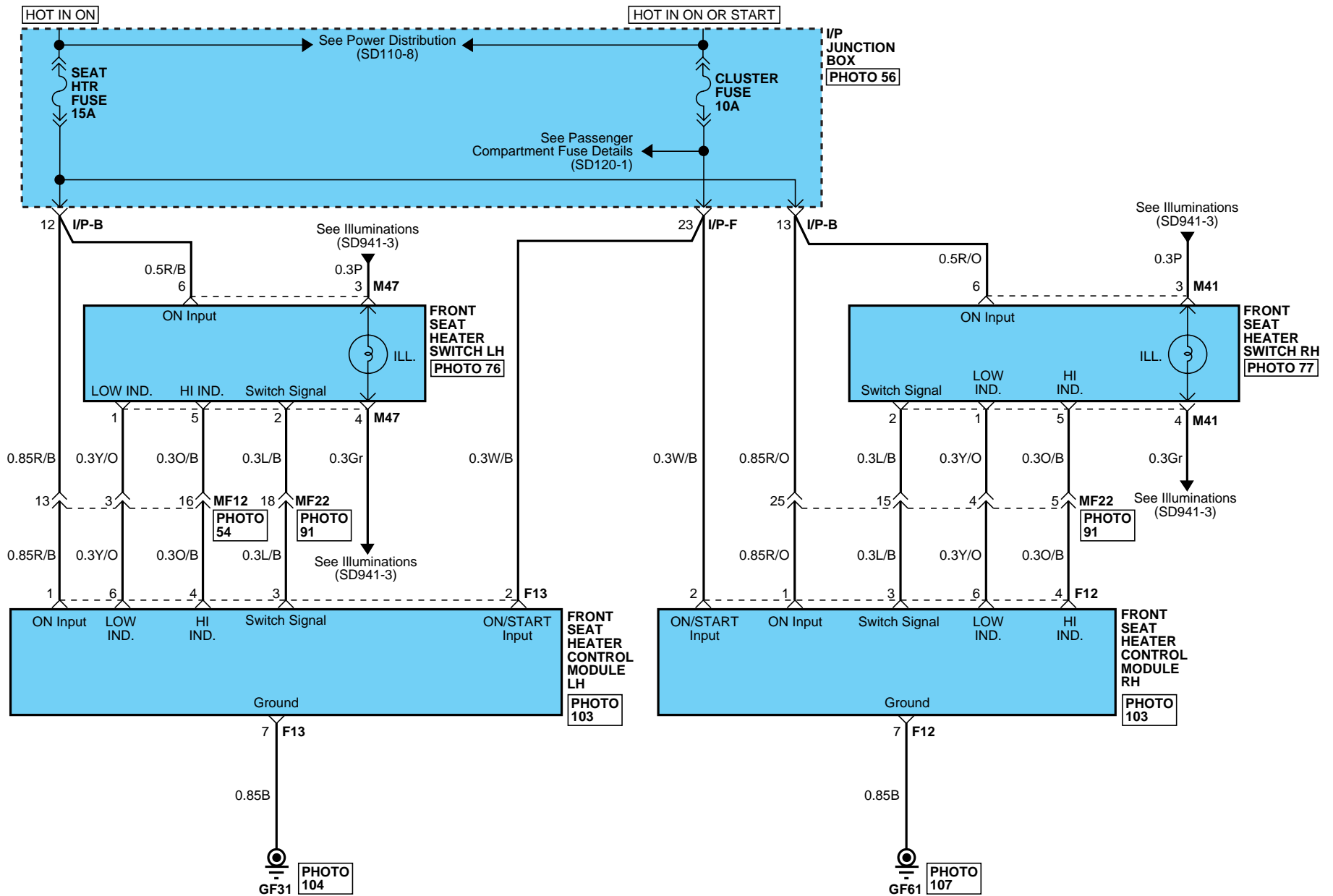

SEAT WARMER

SEAT WARMER (2)

SD889-2

F12

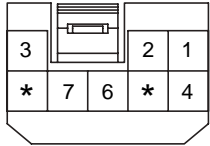

AMP_090III_08F_W

F13

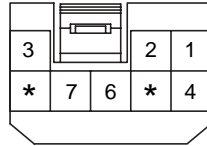

AMP_090III_08F_W

M41

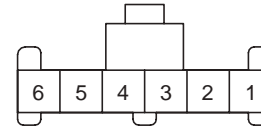

KET_91A_06F_W

M47

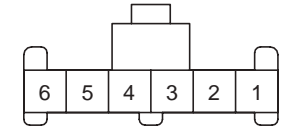

KET_91A_06F_W

HEAD LAMPS (1)

SD921-1

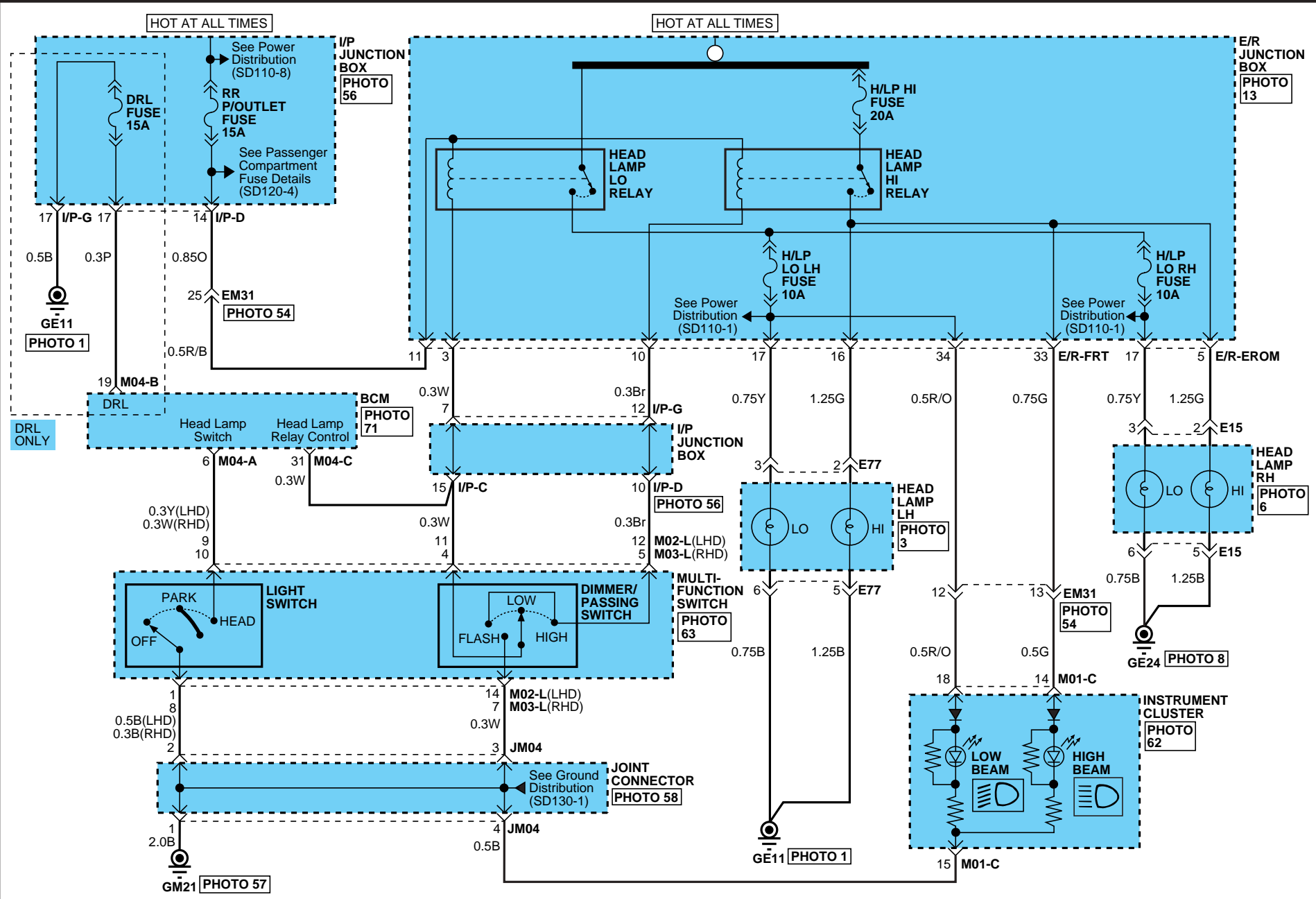

HEAD LAMPS

HEAD LAMPS (2)

SD921-2

E15



KUM_NMWP_06F_B

E77

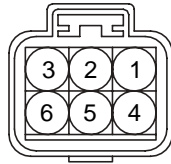

KUM_NMWP_06F_B

M01-C

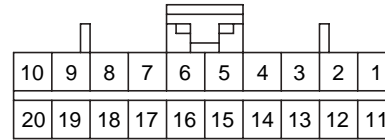

AMP_040M2_20F_B

M02-L

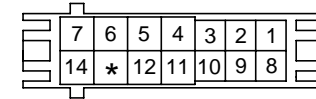

AMP_0409_14F_W

M03-L

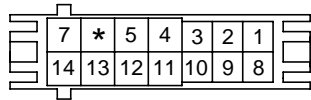

AMP_0409_14F_W

M04-A

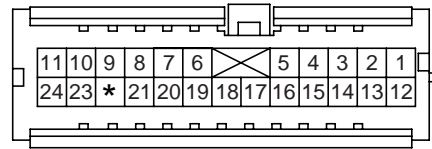

AMP_040III_24F_W

M04-B

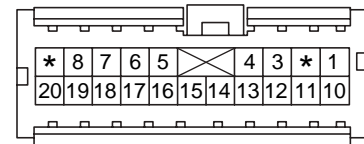

AMP_040III_20F_W

BLANK

M04-C

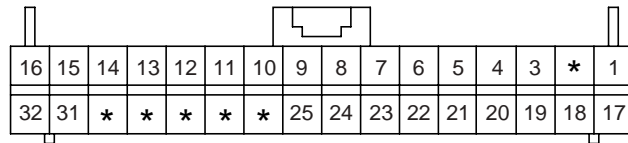

AMP_025_32F_W

BLANK

BLANK

HEAD LAMP LEVELING DEVICE (1)

SD922-1

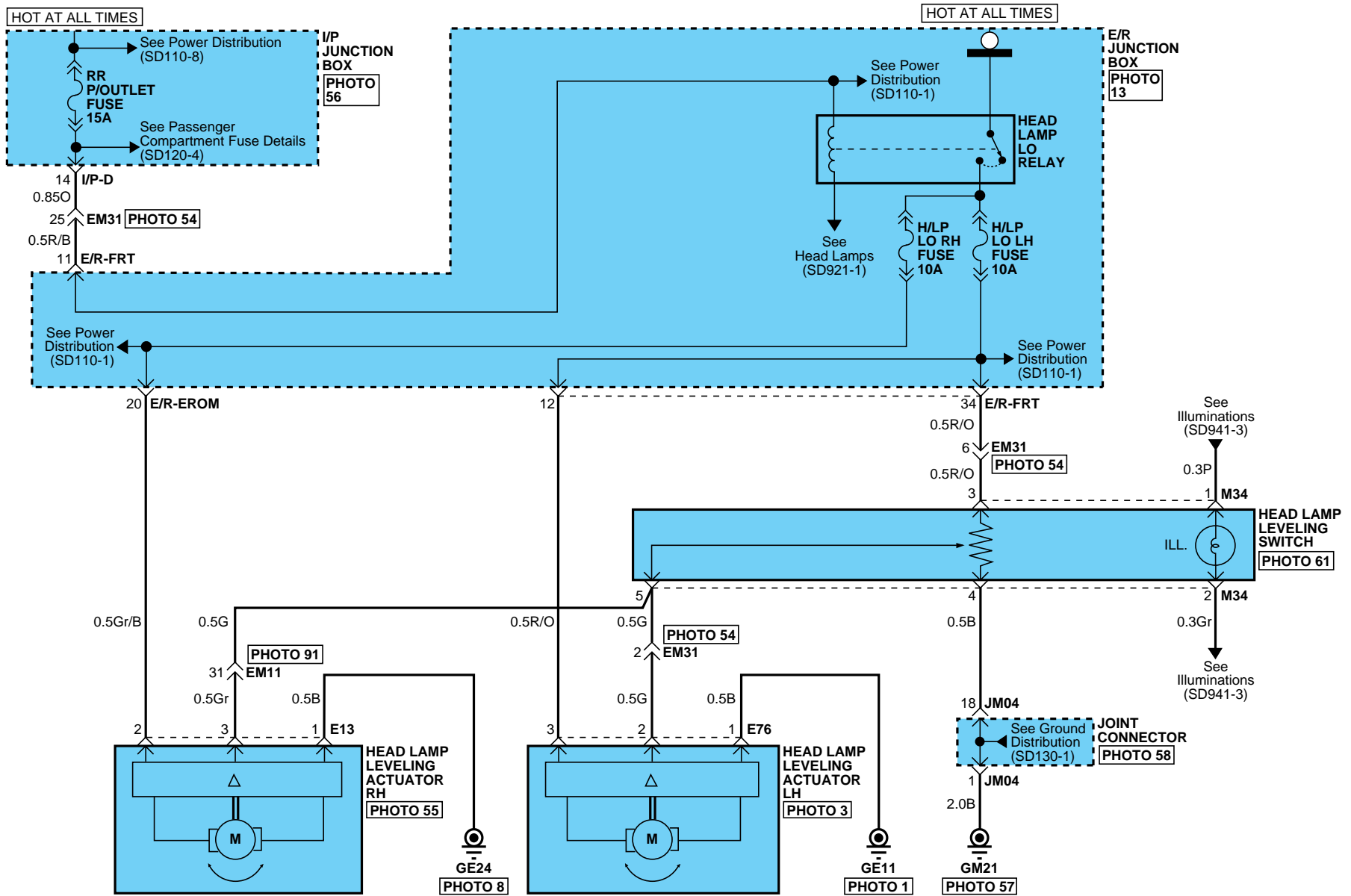

HEAD LAMP LEVELING DEVICE

HEAD LAMP LEVELING DEVICE (2)

SD922-2

E13



KUM_NMWP_03F_B

E76

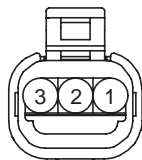

AMP_025WP_03F_B

M34

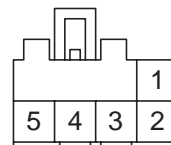

KUM_CDR_05F_W

BLANK

FOG LAMPS (1)

SD924-1

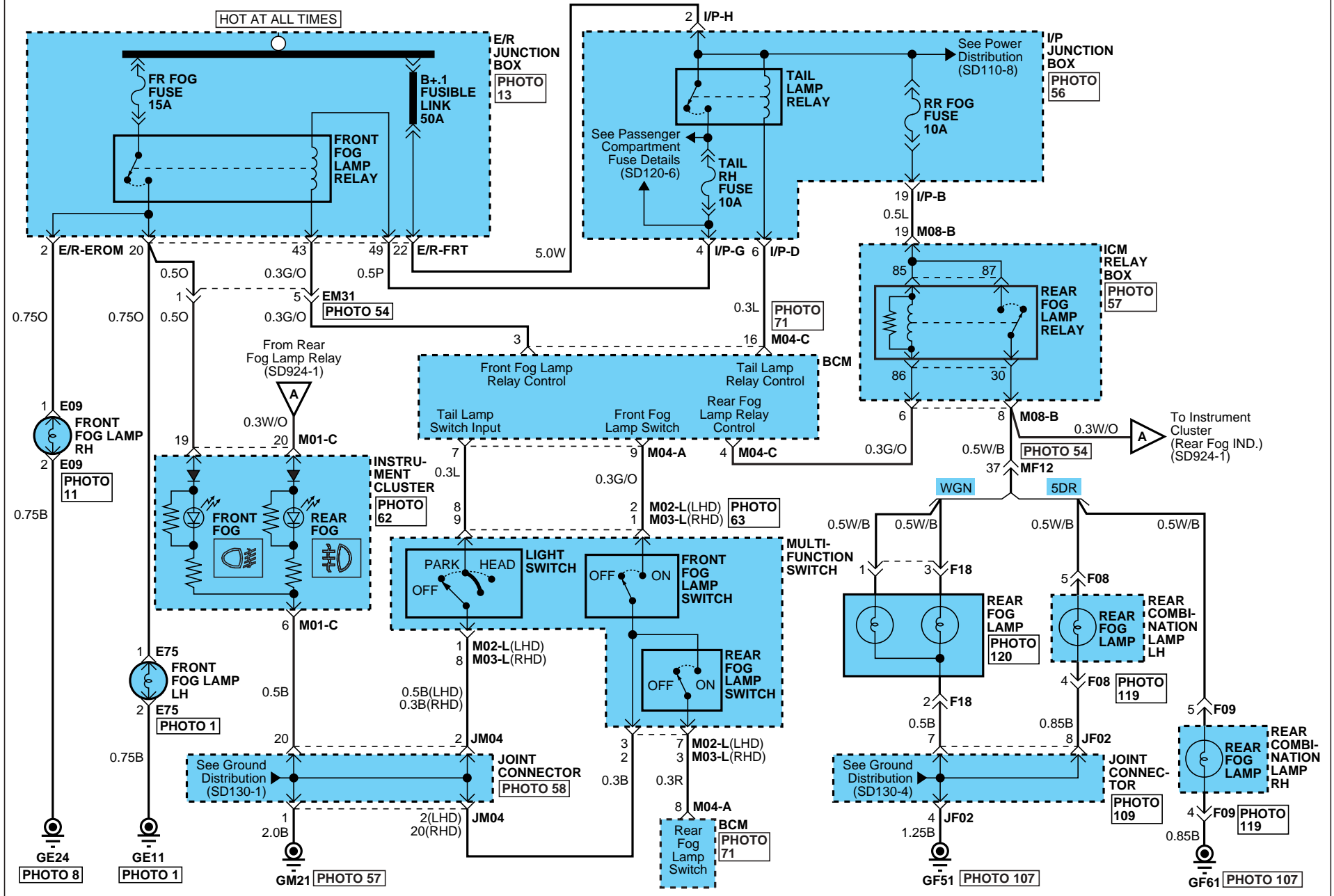

FOG LAMPS

FOG LAMPS (2)

SD924-2

E09



KET_110WP_02F_B_FOG

E75

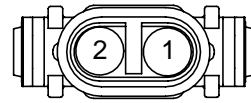

KET_110WP_02F_B_FOG

F08

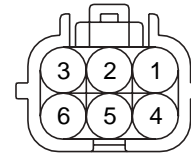

KET_SWP_06F_W

F09

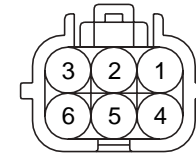

KET_SWP_06F_W

F18

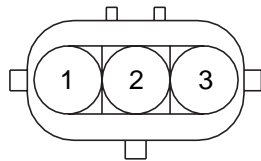

AMP_EJWP_03M_B

M01-C

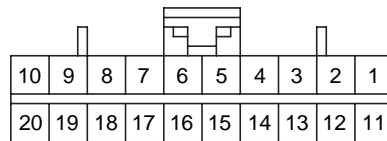

AMP_040M2_20F_B

M02-L

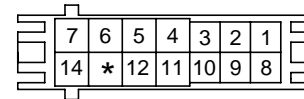

AMP_0409_14F_W

M03-L

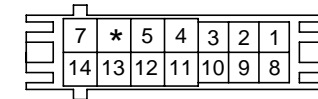

AMP_0409_14F_W

M04-A

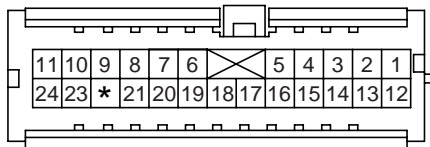

AMP_040III_24F_W

M04-C

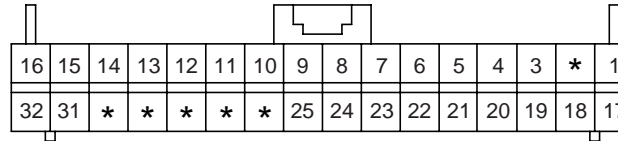

AMP_025_32F_W

M08-B

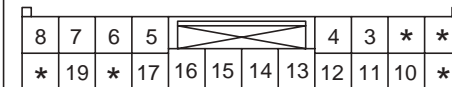

AMP_0925_20F_W

TURN & HAZARD LAMPS (1)

SD925-1

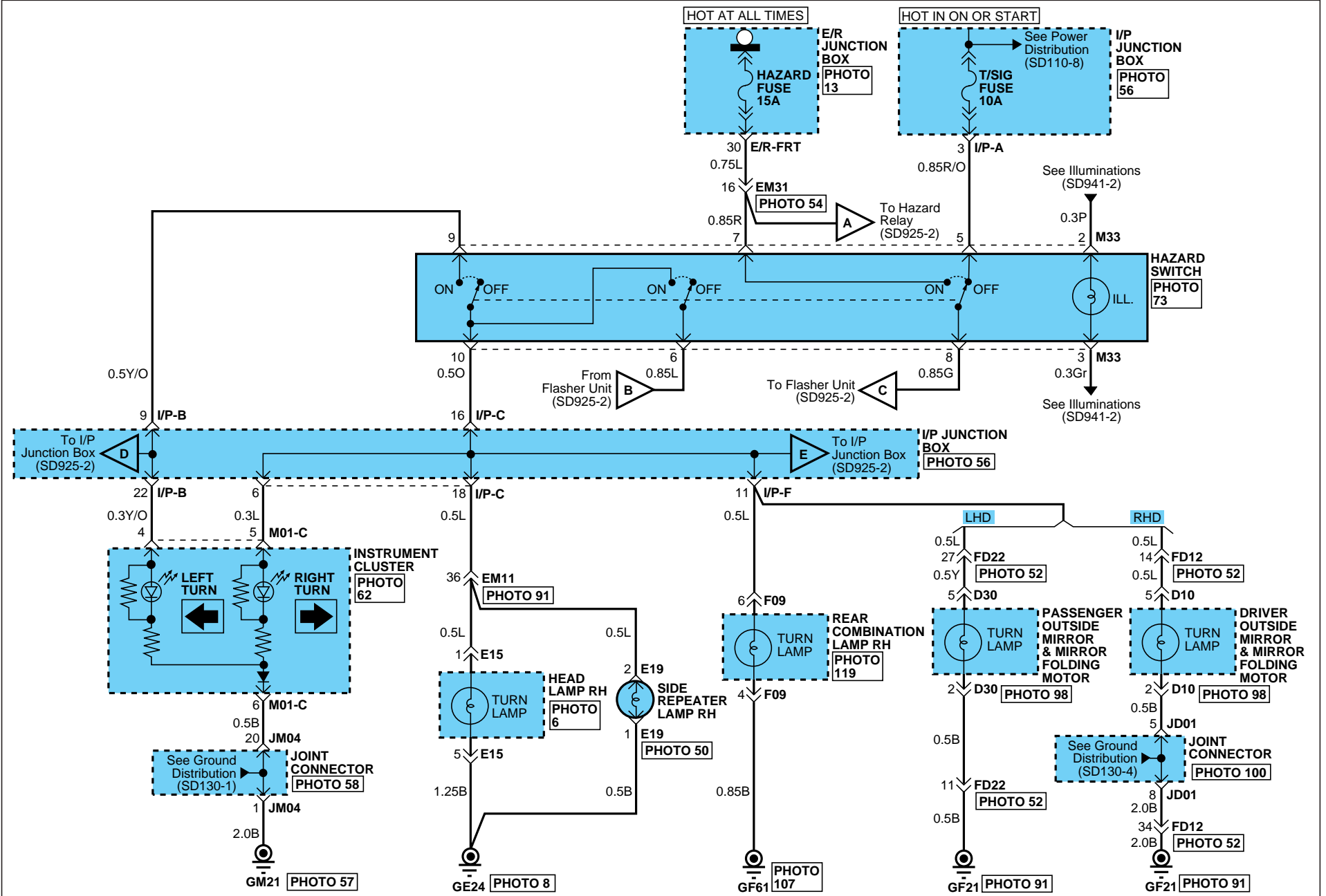

TURN & HAZARD LAMPS

TURN & HAZARD LAMPS (2)

SD925-2

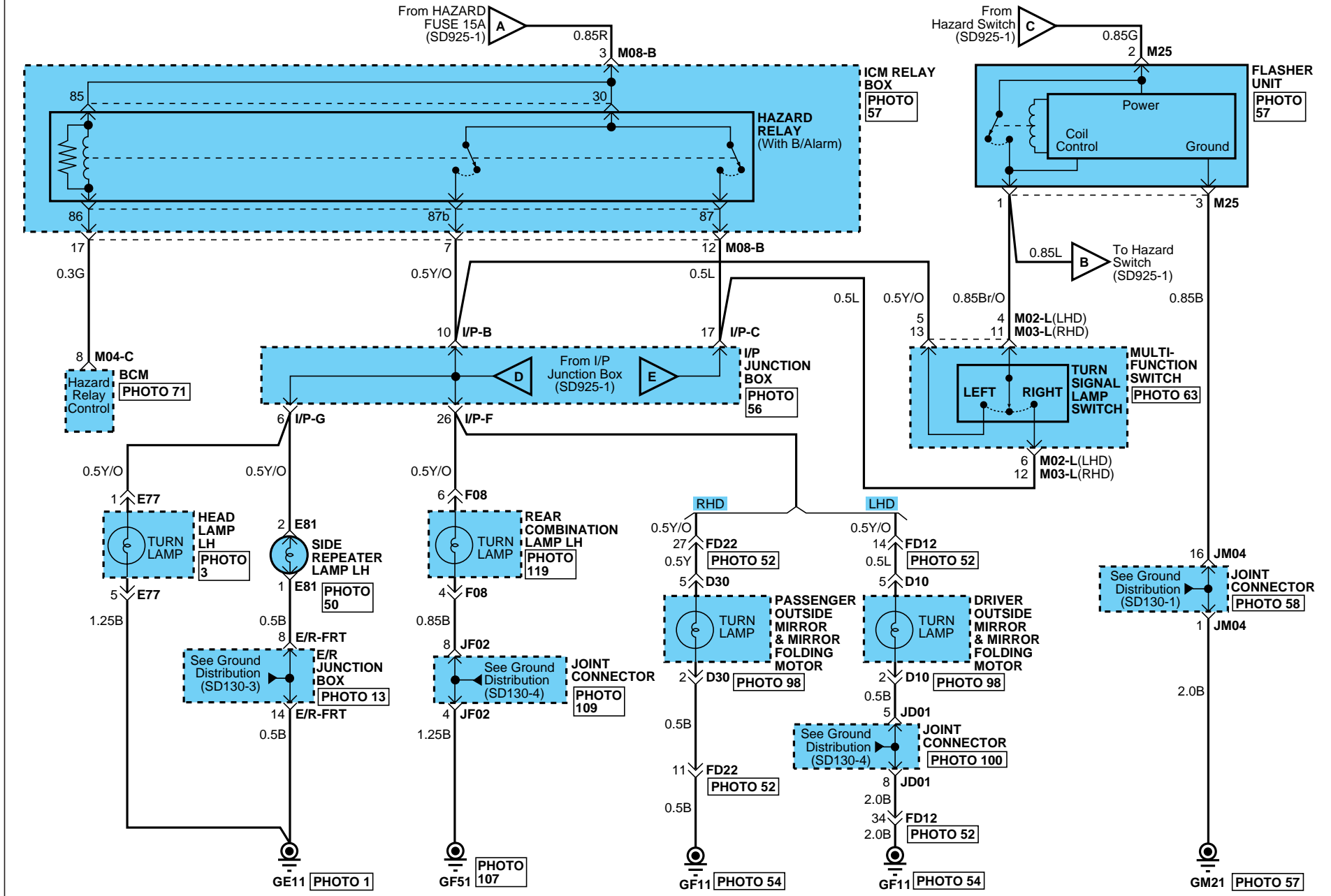

TURN & HAZARD LAMPS

TURN & HAZARD LAMPS (3)

SD925-3

D10

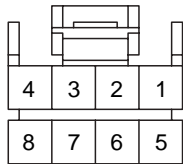

AMP_040M1_08F_B

D30

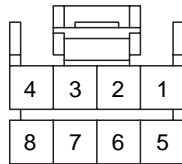

AMP_040M1_08F_B

E15

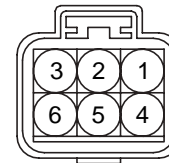

KUM_NMWP_06F_B

E19

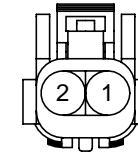

KUM_62Z_02F_GR

E77

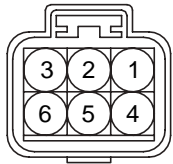

KUM_NMWP_06F_B

E81

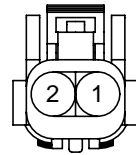

KUM_62Z_02F_GR

F08

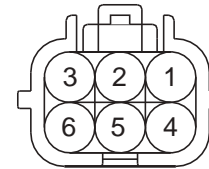

KET_SWP_06F_W

F09

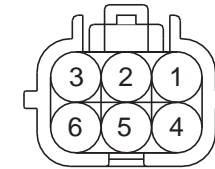

KET_SWP_06F_W

M01-C

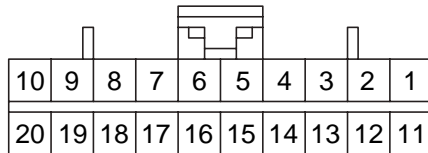

AMP_040M2_20F_B

M02-L

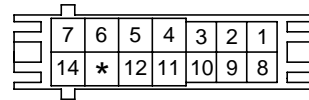

AMP_0409_14F_W

M03-L

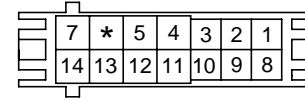

AMP_0409_14F_W

BLANK

M04-C

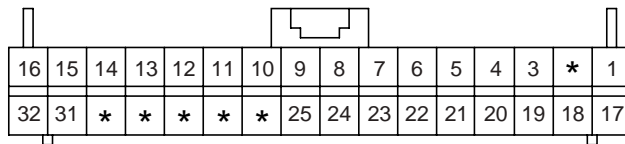

AMP_025_32F_W

M08-B

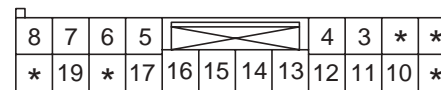

AMP_0925_20F_W

M25

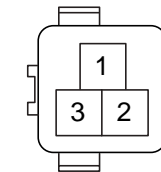

AMP_187_03F_B_RLY

M33

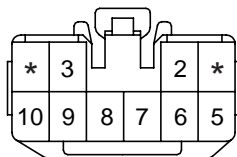

KET_090II_10F_W

BLANK

BLANK

BLANK

TURN & HAZARD LAMPS

TURN & HAZARD LAMPS (4)

SD925-4

MEMO

BACK-UP LAMPS (1)

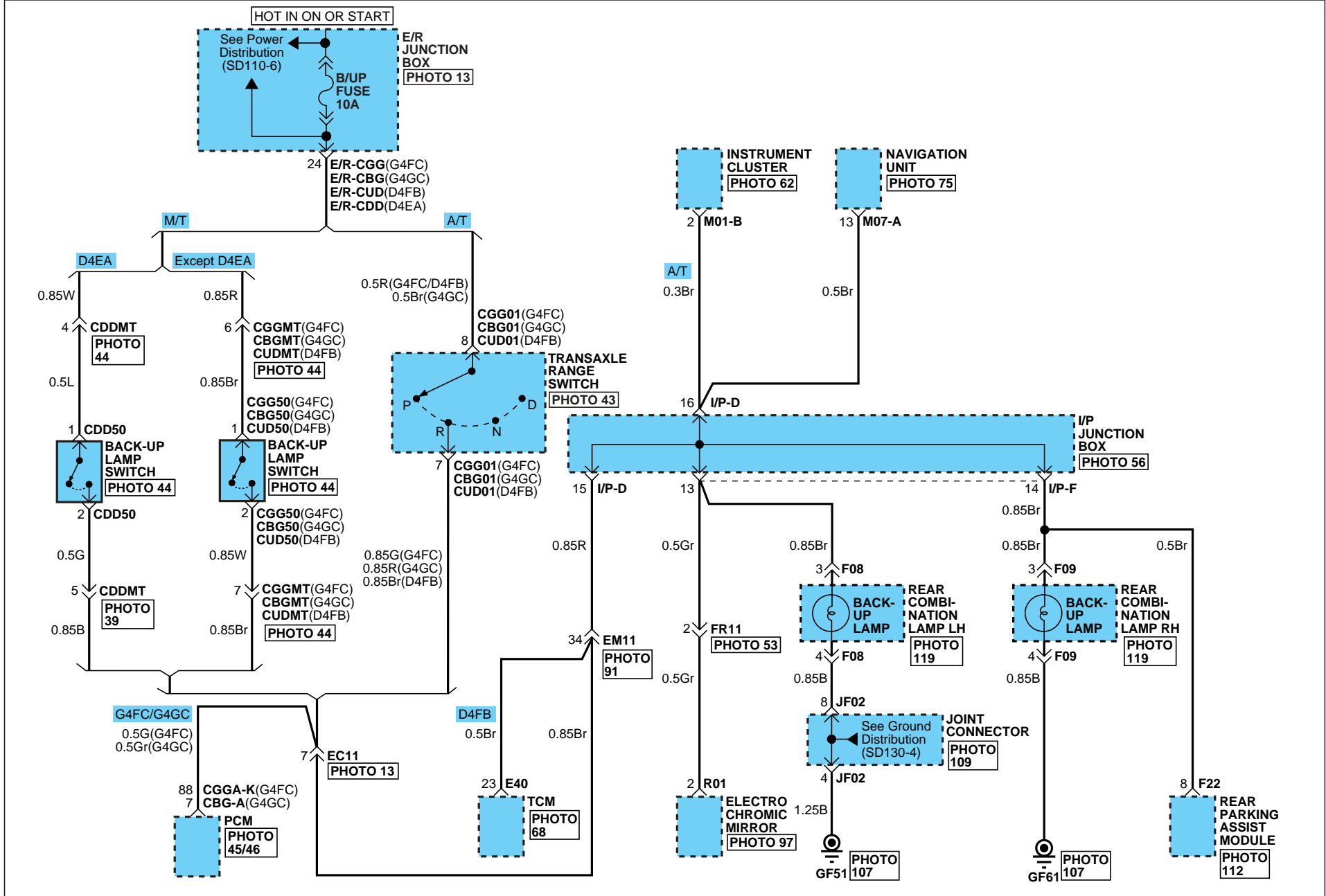

BACK-UP LAMPS

BACK-UP LAMPS (2)

SD926-2

CGGA-K

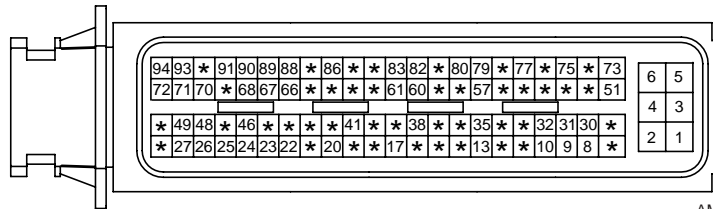

AMP_ECU_94F_B

CBG-A

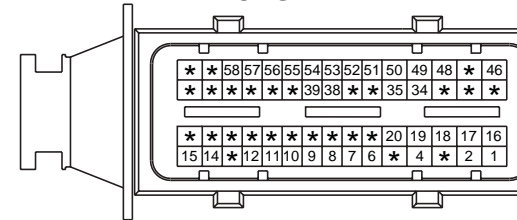

AMP_ECU_60F_B

CGG01



KET_SSD_10F_B_A

CGG50

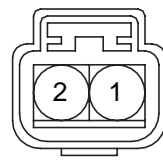

KUM_NMWP_02F_LGr

CBG01



KET_SSD_10F_B_A

CBG50

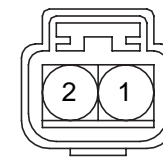

KUM_NMWP_02F_LGr

CUD01



KET_SSD_10F_B_A

CUD50

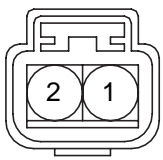

KUM_NMWP_02F_LGr

CDD50

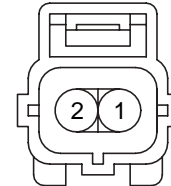

AMP_EJ_MK_II_2F

BLANK

E40

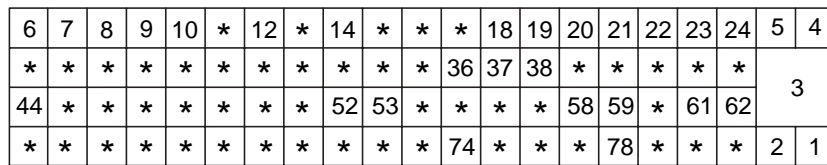

KET_ECU_81F_B_BOSCH

F08

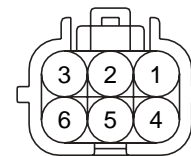

KET_SWP_06F_W

F09

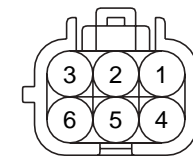

KET_SWP_06F_W

F22

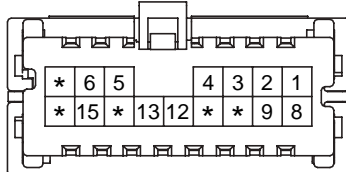

KET_040III_16F_W

M01-B

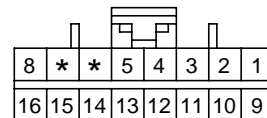

AMP_040M2_16F_B

M07-A

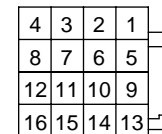

CWB_CY_16F_B

R01

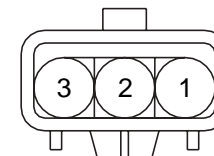

KET_TLCWP_03F_W

STOP LAMPS (1)

SD927-1

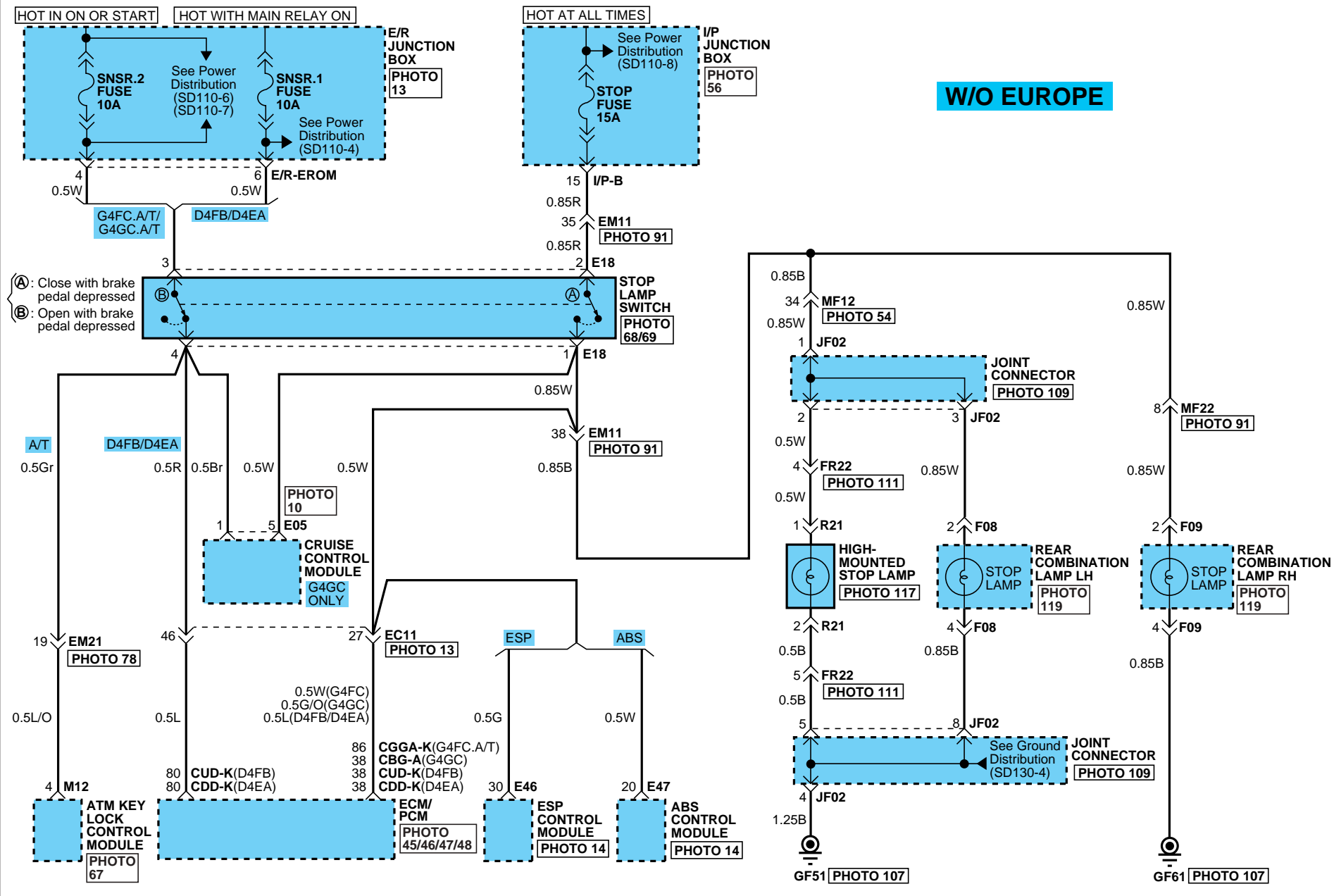

STOP LAMPS

STOP LAMPS (2)

SD927-2

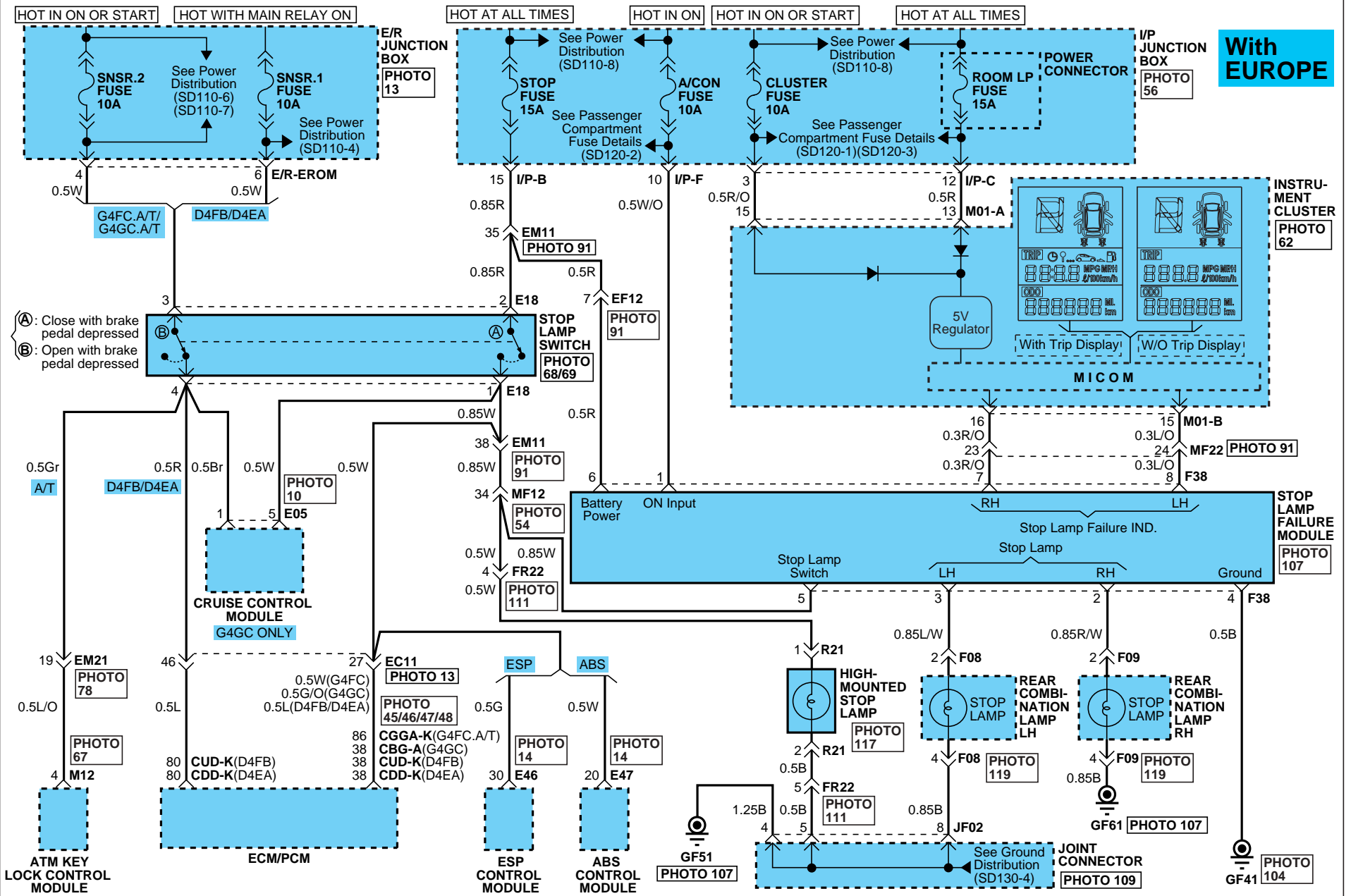

STOP LAMPS

STOP LAMPS (3)

SD927-3

CGGA-K

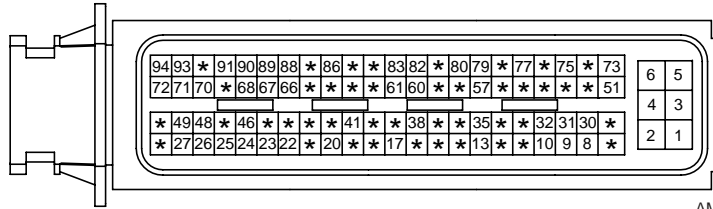

AMP_ECU_94F_B

CBG-A

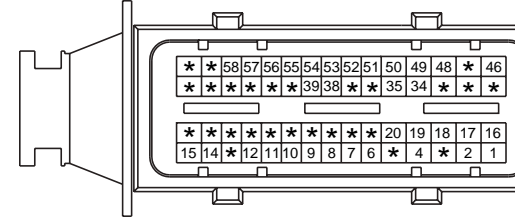

AMP_ECU_60F_B

CUD-K

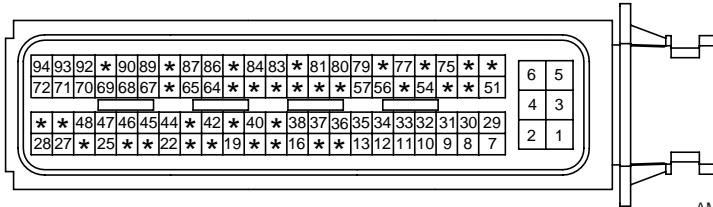

AMP_ECU_94F_B

CDD-K

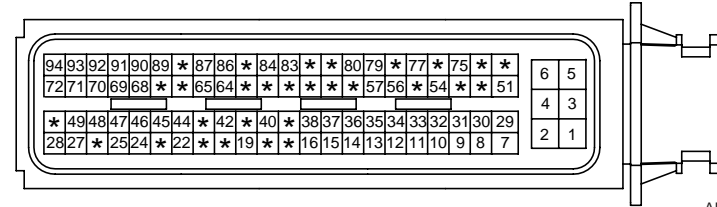

AMP_ECU_94F_B

E05

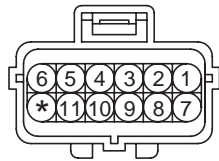

AMP_EJWP_12F_B

E18

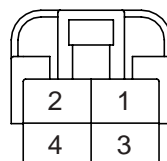

KET_250DL_04F_W

E46

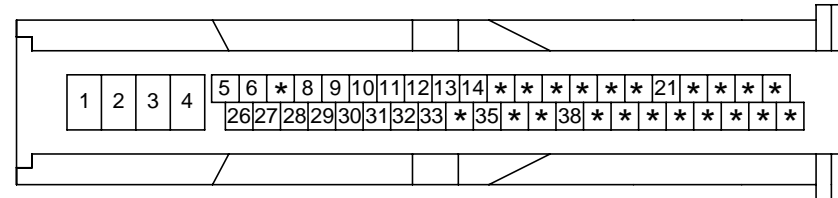

BOS_ESP_46F_B_L

E47

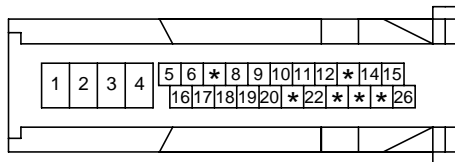

BOS_ABS_26F_B_L

F08

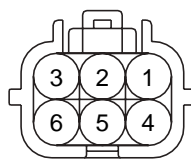

KET_SWP_06F_W

F09

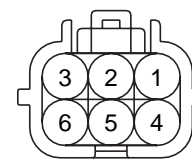

KET_SWP_06F_W

F38

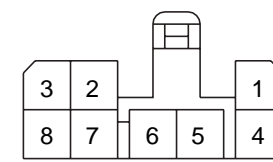

AMP_070_08F_W

M01-A

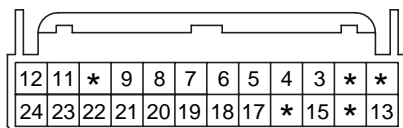

AMP_025_24F_W

M01-B

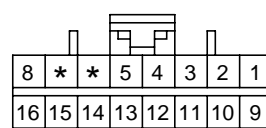

AMP_040M2_16F_B

M12

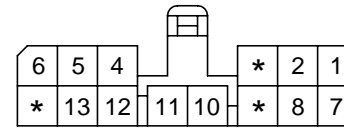

AMP_070_14F_W

R21

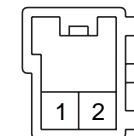

KUM_CDR_02M_W

STOP LAMPS

STOP LAMPS (4)

SD927-4

MEMO

TAIL, PARKING & LICENSE LAMPS (1)

SD928-1

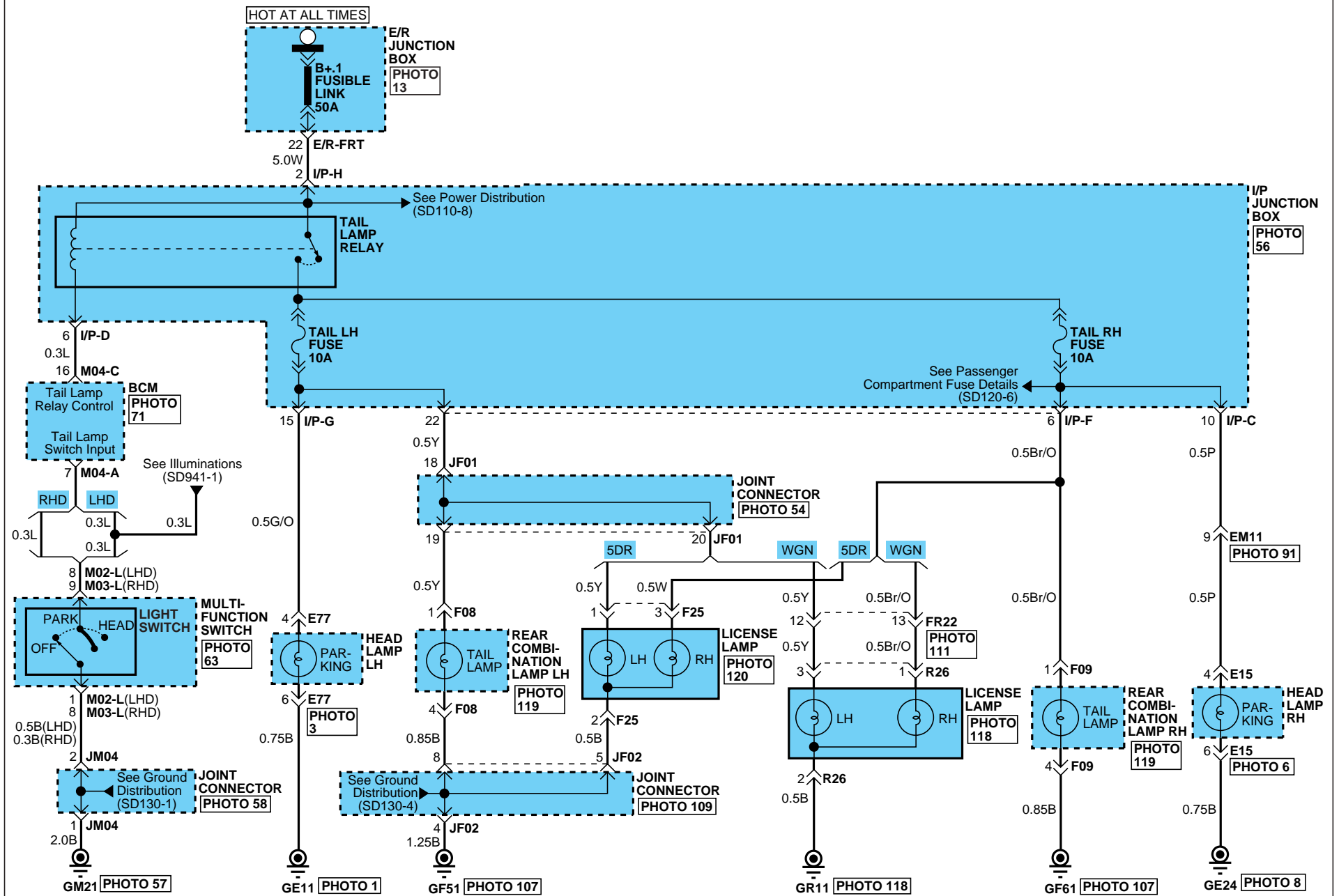

TAIL, PARKING & LICENSE LAMPS

TAIL, PARKING & LICENSE LAMPS (2)

SD928-2

E15



KUM_NMWP_06F_B

E77

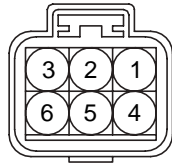

KUM_NMWP_06F_B

F08

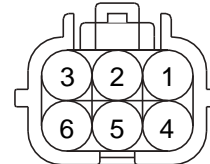

KET_SWP_06F_W

F09

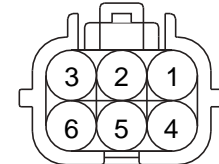

KET_SWP_06F_W

F25

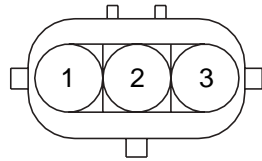

AMP_EJWP_03M_B

M02-L

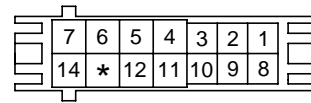

AMP_0409_14F_W

M03-L

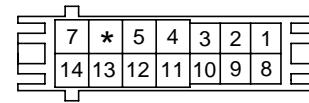

AMP_0409_14F_W

M04-A

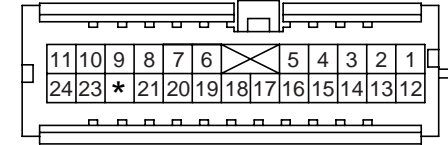

AMP_040III_24F_W

M04-C

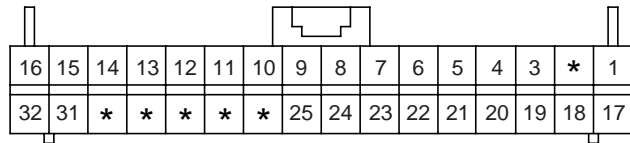

AMP_025_32F_W

R26

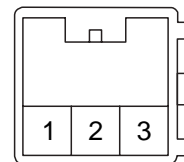

KUM_CDR_03M_W

BLANK

COURTESY & TAIL GATE LAMPS (1)

SD929-1

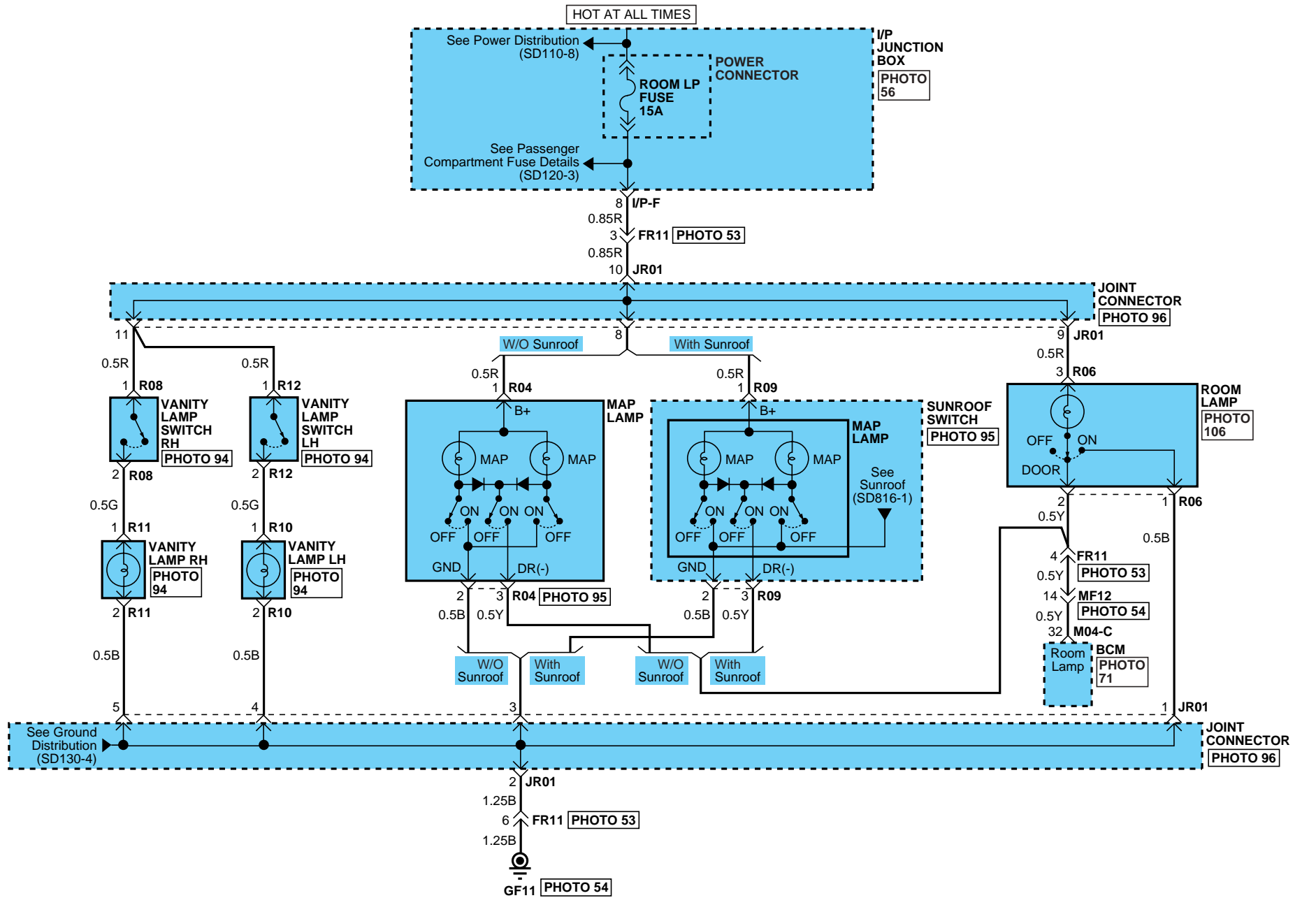

COURTESY & TAIL GATE LAMPS

COURTESY & TAIL GATE LAMPS (2)

SD929-2

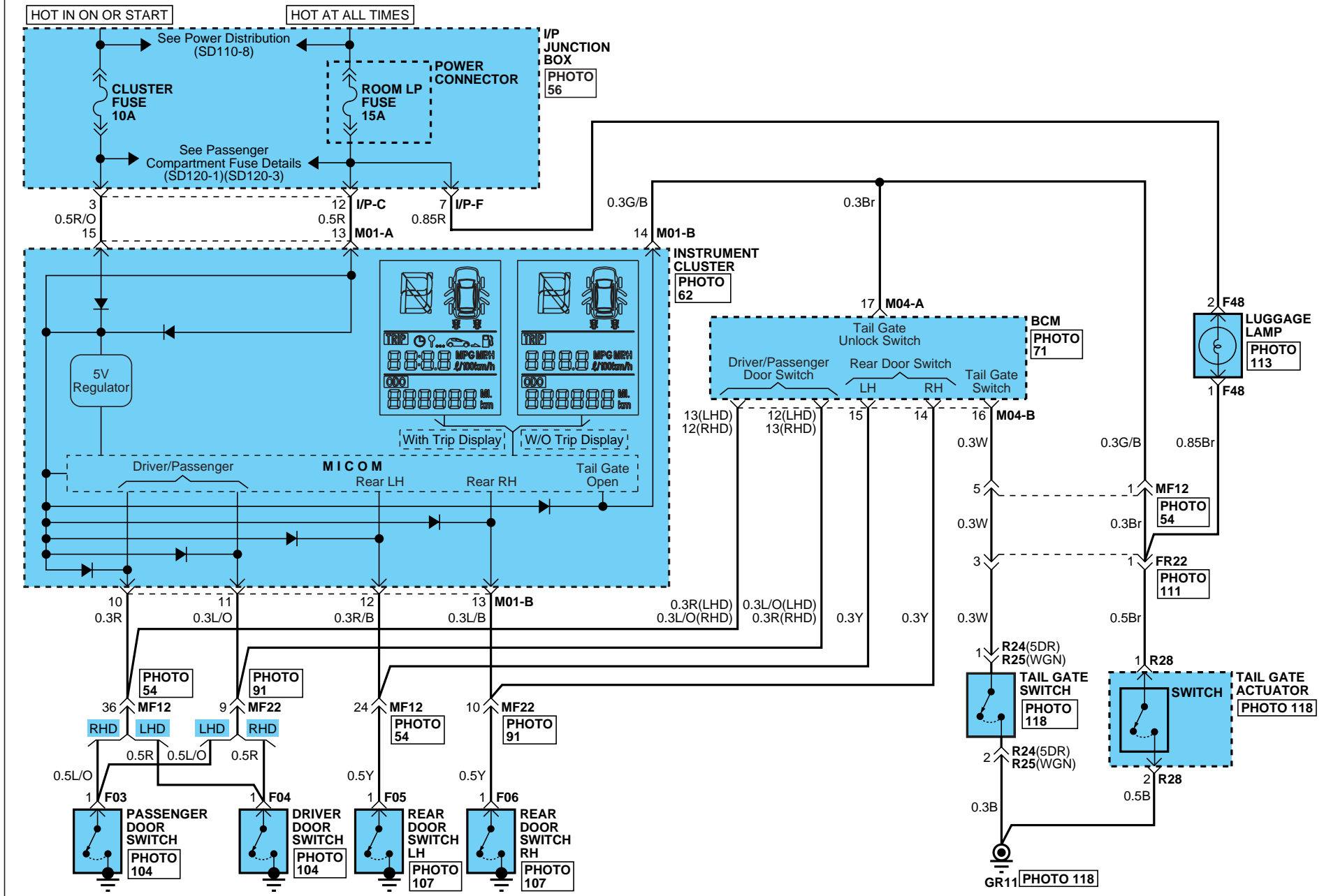

COURTESY & TAIL GATE LAMPS

COURTESY & TAIL GATE LAMPS (3)

SD929-3

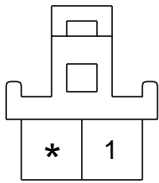
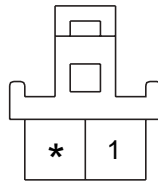
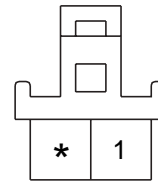
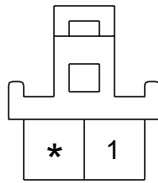
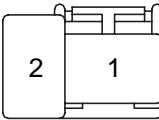
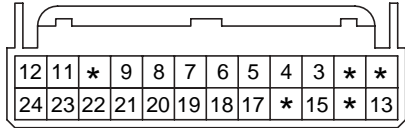
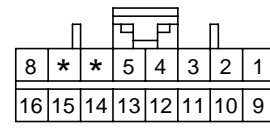
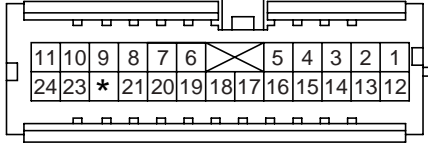
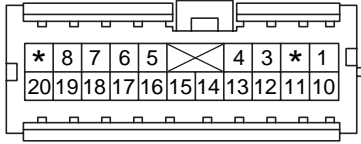
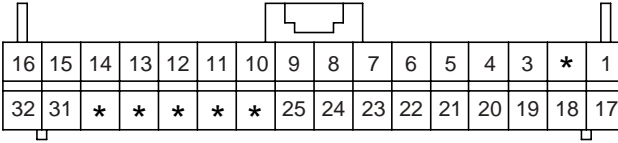
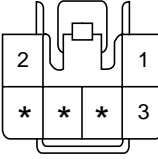
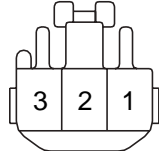
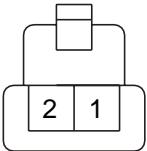
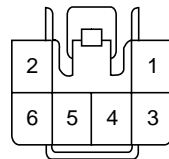
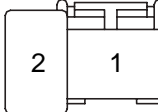
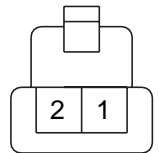
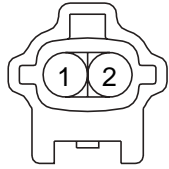
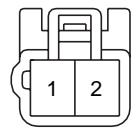
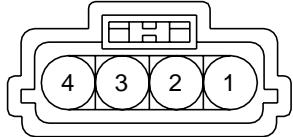
<p>F03</p>  <p>KET_070_02F_W</p>	<p>F04</p>  <p>KET_070_02F_W</p>	<p>F05</p>  <p>KET_070_02F_W</p>	<p>F06</p>  <p>KET_070_02F_W</p>																																																																	
<p>F48</p>  <p>AMP_PLM2_02F_B_DL</p>	<p>M01-A</p>  <table border="1" data-bbox="672 598 1075 678"> <tr><td>12</td><td>11</td><td>*</td><td>9</td><td>8</td><td>7</td><td>6</td><td>5</td><td>4</td><td>3</td><td>*</td><td>*</td></tr> <tr><td>24</td><td>23</td><td>22</td><td>21</td><td>20</td><td>19</td><td>18</td><td>17</td><td>*</td><td>15</td><td>*</td><td>13</td></tr> </table> <p>AMP_025_24F_W</p>	12	11	*	9	8	7	6	5	4	3	*	*	24	23	22	21	20	19	18	17	*	15	*	13	<p>M01-B</p>  <table border="1" data-bbox="1209 598 1478 678"> <tr><td>8</td><td>*</td><td>*</td><td>5</td><td>4</td><td>3</td><td>2</td><td>1</td></tr> <tr><td>16</td><td>15</td><td>14</td><td>13</td><td>12</td><td>11</td><td>10</td><td>9</td></tr> </table> <p>AMP_040M2_16F_B</p>	8	*	*	5	4	3	2	1	16	15	14	13	12	11	10	9	<p>M04-A</p>  <table border="1" data-bbox="1612 574 2038 638"> <tr><td>11</td><td>10</td><td>9</td><td>8</td><td>7</td><td>6</td><td>⊗</td><td>5</td><td>4</td><td>3</td><td>2</td><td>1</td></tr> <tr><td>24</td><td>23</td><td>*</td><td>21</td><td>20</td><td>19</td><td>18</td><td>17</td><td>16</td><td>15</td><td>14</td><td>13</td><td>12</td></tr> </table> <p>AMP_040III_24F_W</p>	11	10	9	8	7	6	⊗	5	4	3	2	1	24	23	*	21	20	19	18	17	16	15	14	13	12
12	11	*	9	8	7	6	5	4	3	*	*																																																									
24	23	22	21	20	19	18	17	*	15	*	13																																																									
8	*	*	5	4	3	2	1																																																													
16	15	14	13	12	11	10	9																																																													
11	10	9	8	7	6	⊗	5	4	3	2	1																																																									
24	23	*	21	20	19	18	17	16	15	14	13	12																																																								
<p>M04-B</p>  <table border="1" data-bbox="212 845 571 909"> <tr><td>*</td><td>8</td><td>7</td><td>6</td><td>5</td><td>⊗</td><td>4</td><td>3</td><td>*</td><td>1</td></tr> <tr><td>20</td><td>19</td><td>18</td><td>17</td><td>16</td><td>15</td><td>14</td><td>13</td><td>12</td><td>11</td><td>10</td></tr> </table> <p>AMP_040III_20F_W</p>	*	8	7	6	5	⊗	4	3	*	1	20	19	18	17	16	15	14	13	12	11	10	<p>M04-C</p>  <table border="1" data-bbox="806 829 1422 917"> <tr><td>16</td><td>15</td><td>14</td><td>13</td><td>12</td><td>11</td><td>10</td><td>9</td><td>8</td><td>7</td><td>6</td><td>5</td><td>4</td><td>3</td><td>*</td><td>1</td></tr> <tr><td>32</td><td>31</td><td>*</td><td>*</td><td>*</td><td>*</td><td>*</td><td>25</td><td>24</td><td>23</td><td>22</td><td>21</td><td>20</td><td>19</td><td>18</td><td>17</td></tr> </table> <p>AMP_025_32F_W</p>		16	15	14	13	12	11	10	9	8	7	6	5	4	3	*	1	32	31	*	*	*	*	*	25	24	23	22	21	20	19	18	17	<p>R04</p>  <p>KET_090_06F_W</p>												
*	8	7	6	5	⊗	4	3	*	1																																																											
20	19	18	17	16	15	14	13	12	11	10																																																										
16	15	14	13	12	11	10	9	8	7	6	5	4	3	*	1																																																					
32	31	*	*	*	*	*	25	24	23	22	21	20	19	18	17																																																					
<p>R06</p>  <p>KET_090II_03F_W</p>	<p>R08</p>  <p>AMP_040MI_02F_B</p>	<p>R09</p>  <p>KET_090_06F_W</p>	<p>R10/R11</p>  <p>AMP_PLM2_02F_B_DL</p>																																																																	
<p>R12</p>  <p>AMP_040MI_02F_B</p>	<p>R24</p>  <p>KET_090IWP_02M_B</p>	<p>R25</p>  <p>KET_090II_02M_B_R</p>	<p>R28</p>  <p>KUM_NDWP_04F_B</p>																																																																	

COURTESY & TAIL GATE LAMPS

COURTESY & TAIL GATE LAMPS (4)

SD929-4

MEMO

INDICATORS & GAUGES (1)

SD940-1

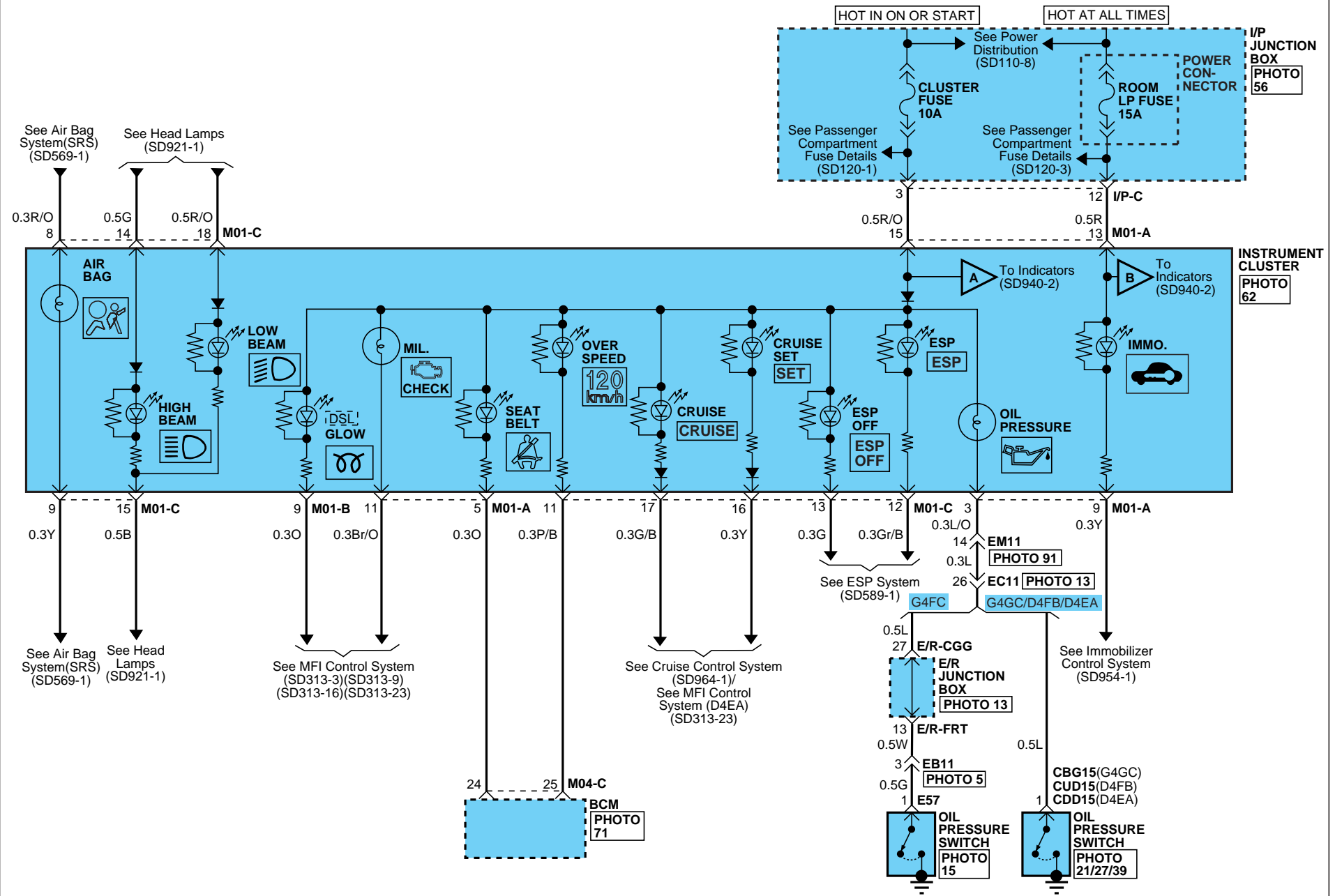

INDICATORS & GAUGES

INDICATORS & GAUGES (2)

SD940-2

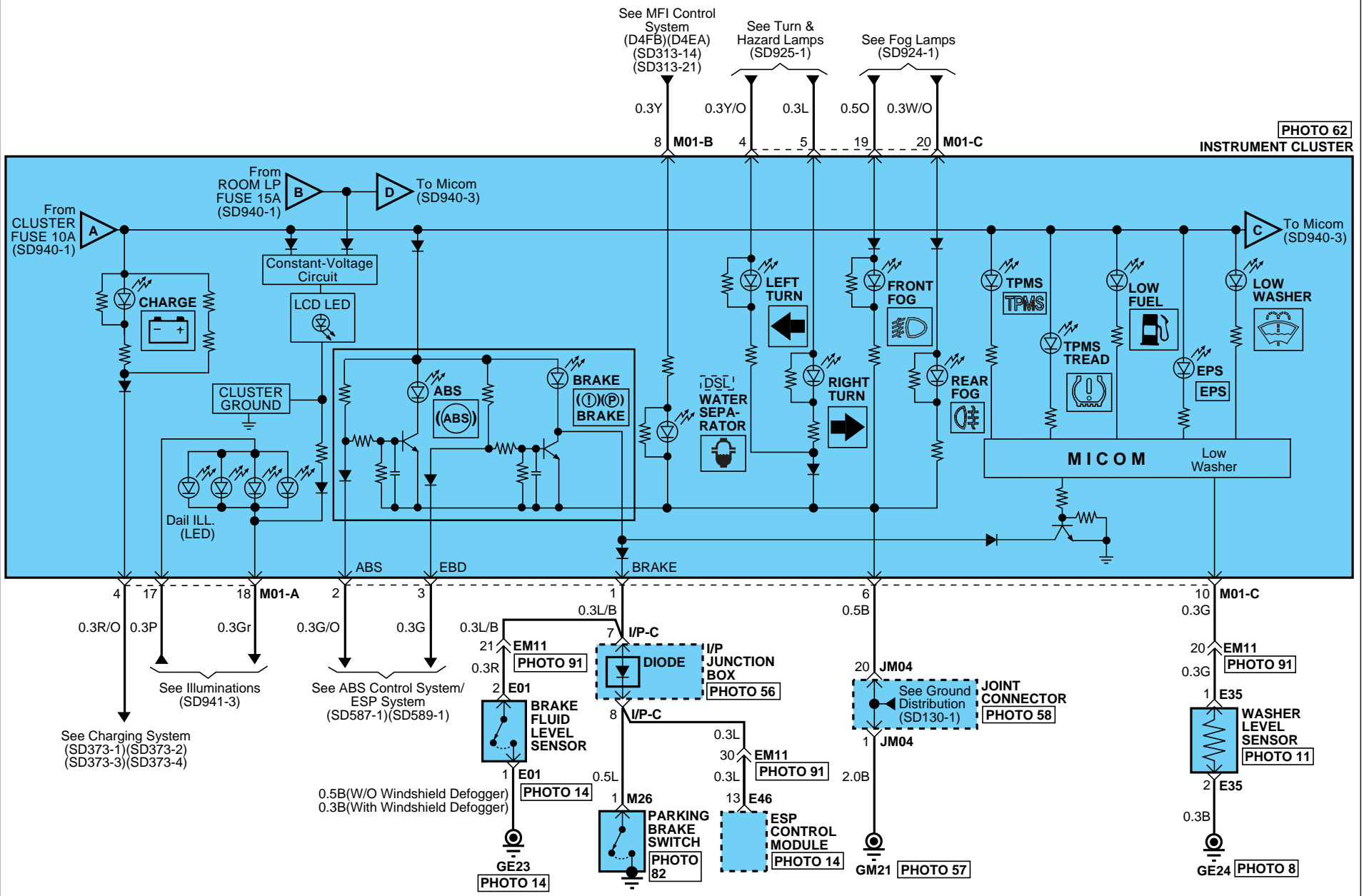

INDICATORS & GAUGES

INDICATORS & GAUGES (3)

SD940-3

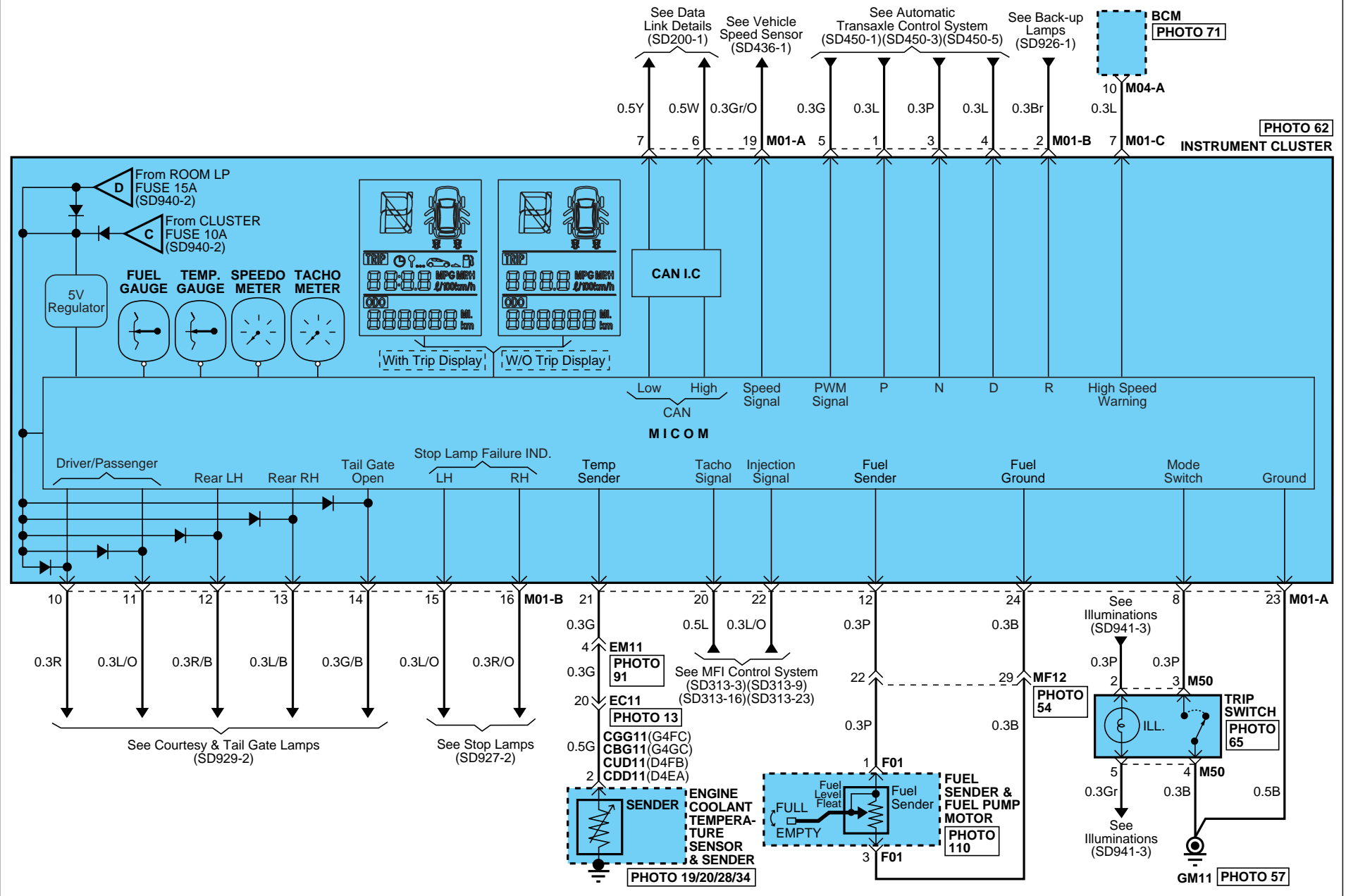

INDICATORS & GAUGES

INDICATORS & GAUGES (4)

SD940-4

CGG11

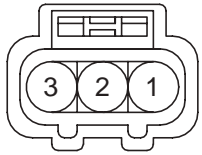

KUM_62Z_03F_B_WTS

CBG11

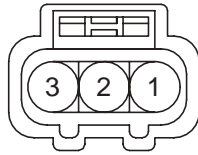

KUM_62Z_03F_B_WTS

CBG15

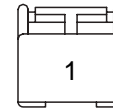

AMP_PLM2_01F_B

CUD11

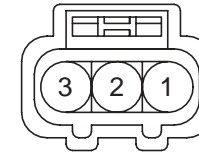

KUM_62Z_03F_B_WTS

CUD15/CDD15



KUM_NMWP_01F_B

CDD11

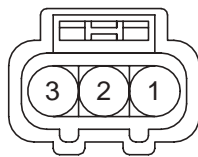

KUM_62Z_03F_B_WTS

E01

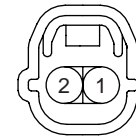

KET_SSD_02F_B

E35

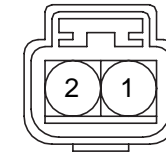

KUM_NMWP_02F_B

E46

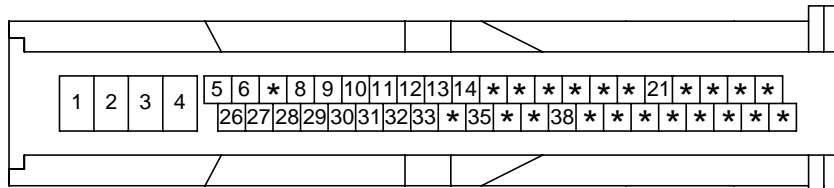

BOS_ESP_46F_B_L

E57



KUM_NMWP_01F_B

F01



KUM_090IWP_06F_B

M01-A

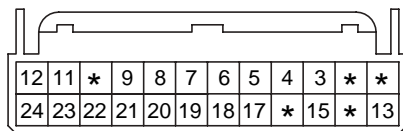

AMP_025_24F_W

M01-B

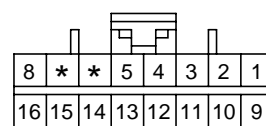

AMP_040M2_16F_B

M01-C

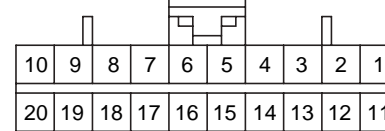

AMP_040M2_20F_B

M04-A

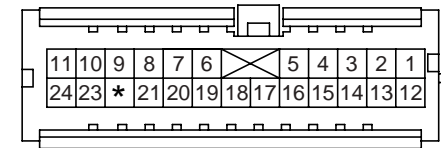

AMP_040III_24F_W

M04-C

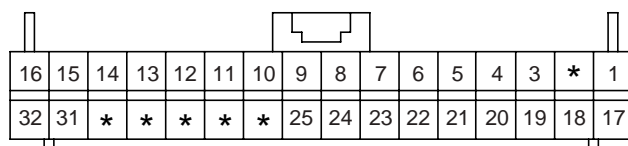

AMP_025_32F_W

M26

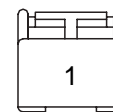

AMP_PLM2_01F_B_DL

M50

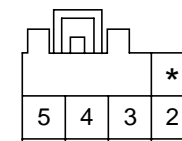

KUM_CDR_05F_B

ILLUMINATIONS (1)

SD941-1

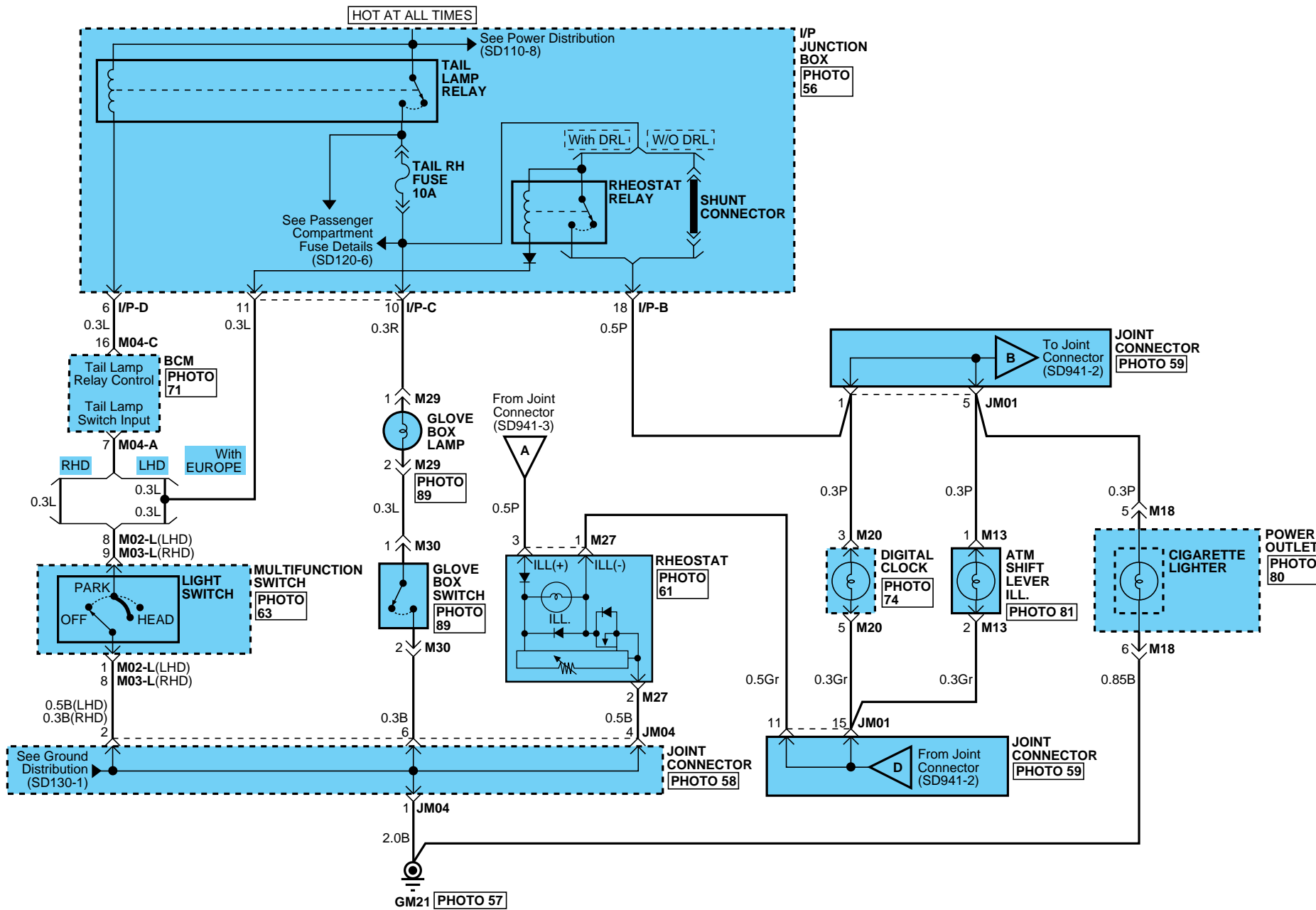

ILLUMINATIONS

ILLUMINATIONS (2)

SD941-2

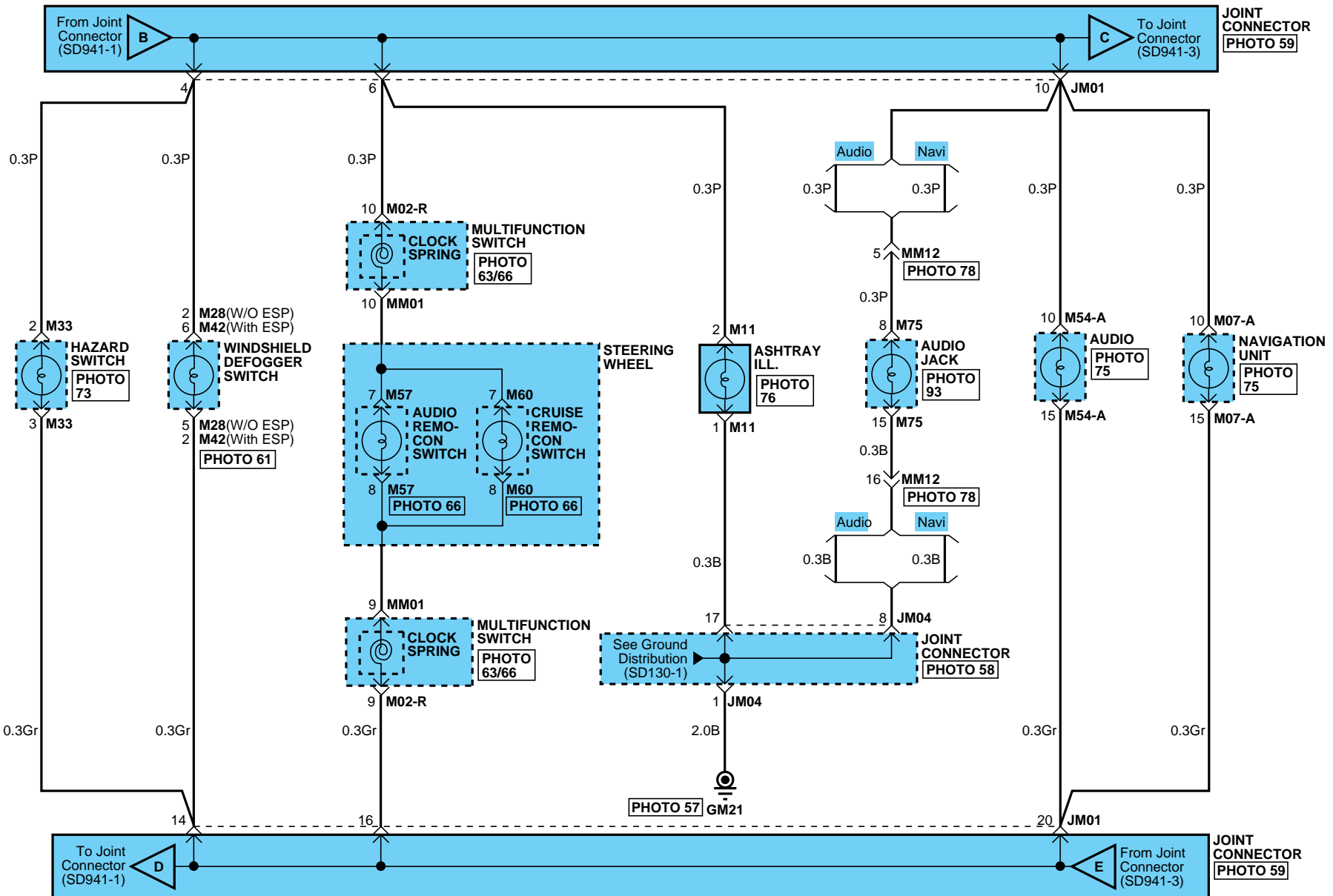

ILLUMINATIONS

ILLUMINATIONS (3)

SD941-3

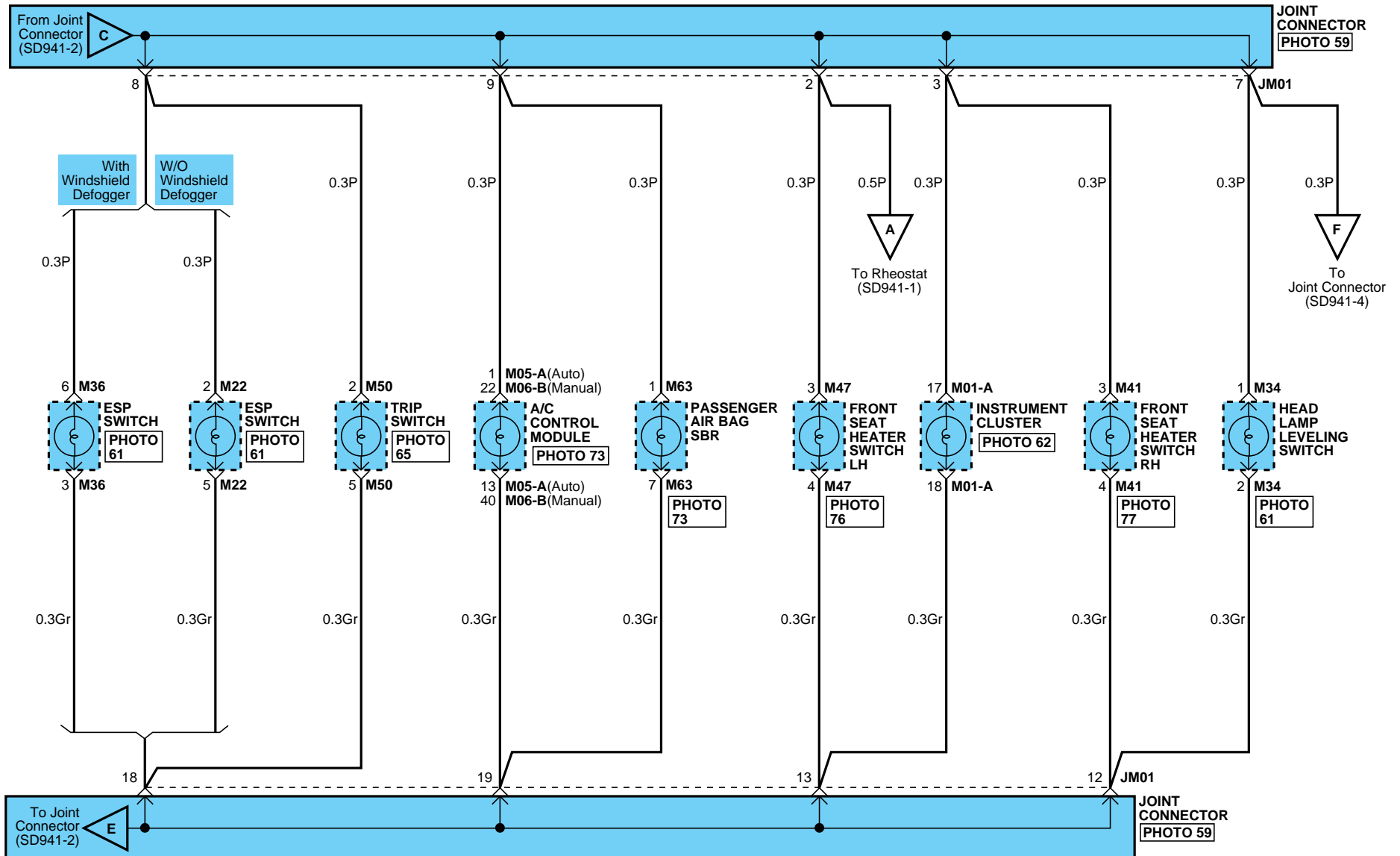

ILLUMINATIONS

ILLUMINATIONS (4)

SD941-4

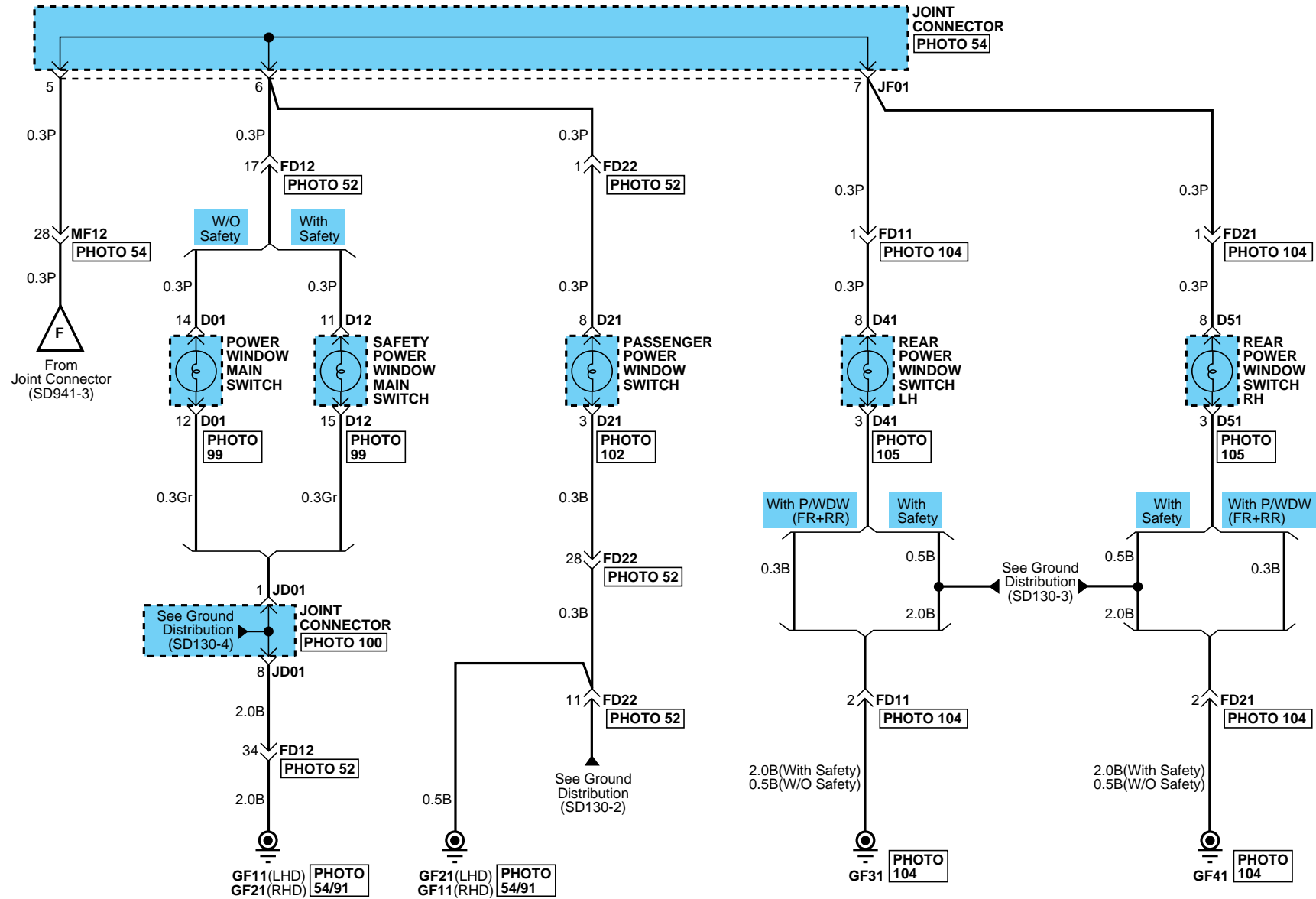

ILLUMINATIONS

ILLUMINATIONS (5)

SD941-5

D01

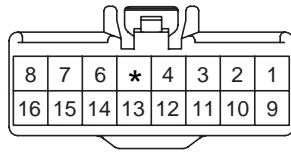

KET_090III_16F_W

D12

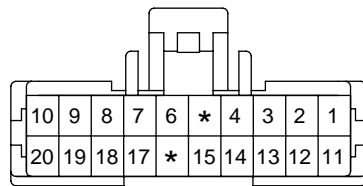

KET_SP_20F_W

D21

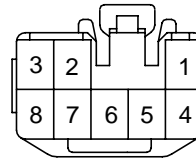

KET_090II_08F_W

D41

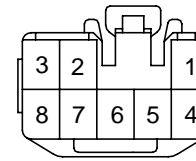

KET_090II_08F_W

D51

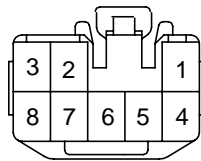

KET_090II_08F_W

M01-A

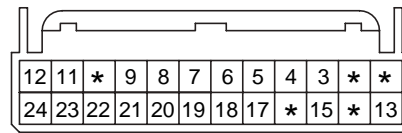

AMP_025_24F_W

M02-L

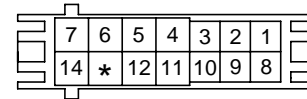

AMP_0409_14F_W

M02-R

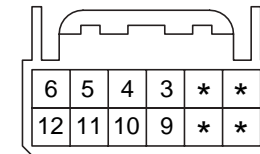

AMP_025_12F_W

M03-L

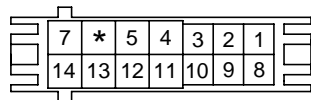

AMP_0409_14F_W

M04-A

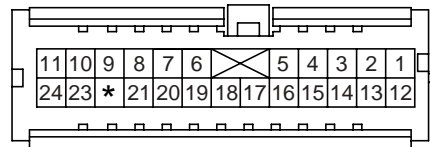

AMP_040III_24F_W

M04-C

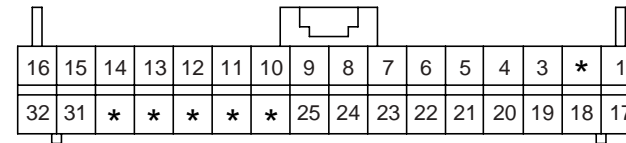

AMP_025_32F_W

M05-A

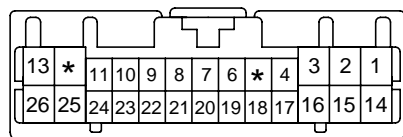

KET_0407_26F_W

M06-B

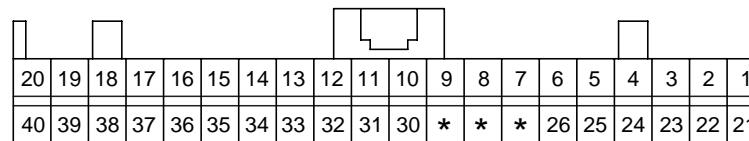

AMP_025_40F_W

M07-A

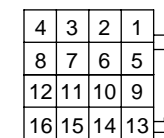

CWB_CY_16F_B

M11

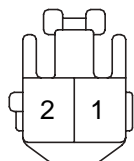

KET_090II_02F_W_L

M13

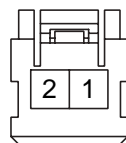

AMP_090III_02F_W

M18

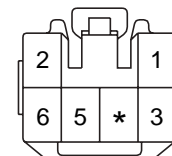

KET_090II_06F_W

M20

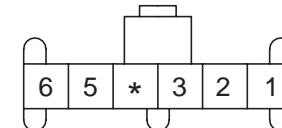

KET_91A_06F_W

ILLUMINATIONS

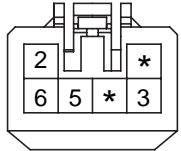
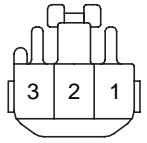
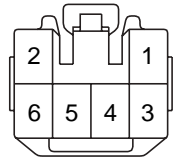
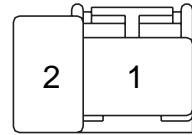
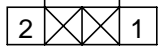
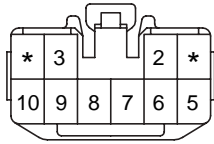
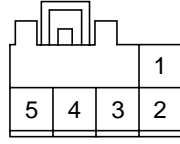
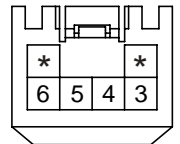
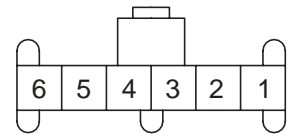
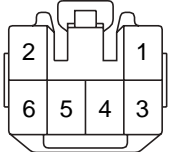
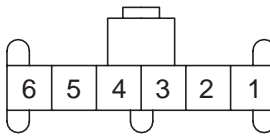
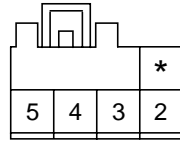
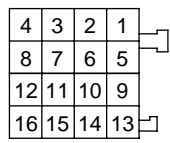
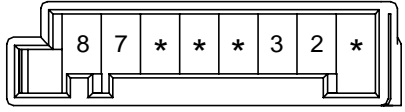
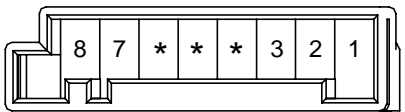
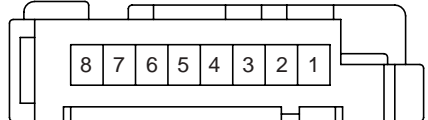
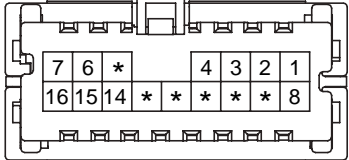
ILLUMINATIONS (6)			SD941-6
<p>M22</p>  <p>AMP_090III_06F_Y_S2</p>	<p>M27</p>  <p>KET_090II_03F_B</p>	<p>M28</p>  <p>KET_090II_06F_L</p>	<p>M29</p>  <p>AMP_PLM2_02F_B_DL</p>
<p>M30</p>  <p>KET_187_02F_W</p>	<p>M33</p>  <p>KET_090II_10F_W</p>	<p>M34</p>  <p>KUM_CDR_05F_W</p>	<p>M36</p>  <p>KET_090II_06F_Y_2</p>
<p>M41</p>  <p>KET_91A_06F_W</p>	<p>M42</p>  <p>KET_090II_06F_L</p>	<p>M47</p>  <p>KET_91A_06F_W</p>	<p>M50</p>  <p>KUM_CDR_05F_B</p>
<p>M54-A</p>  <p>CWB_CY_16F_B</p>	<p>M57</p>  <p>CR08F068</p>	<p>M60</p>  <p>CR08F068</p>	<p>M63</p>  <p>AMP_MQS_08F_W</p>
<p>M75</p>  <p>KET_040III_16F_W</p>	<p>BLANK</p>	<p>BLANK</p>	<p>BLANK</p>

DIGITAL CLOCK & CIGARETTE LIGHTER (POWER OUTLET) (1)

SD945-1

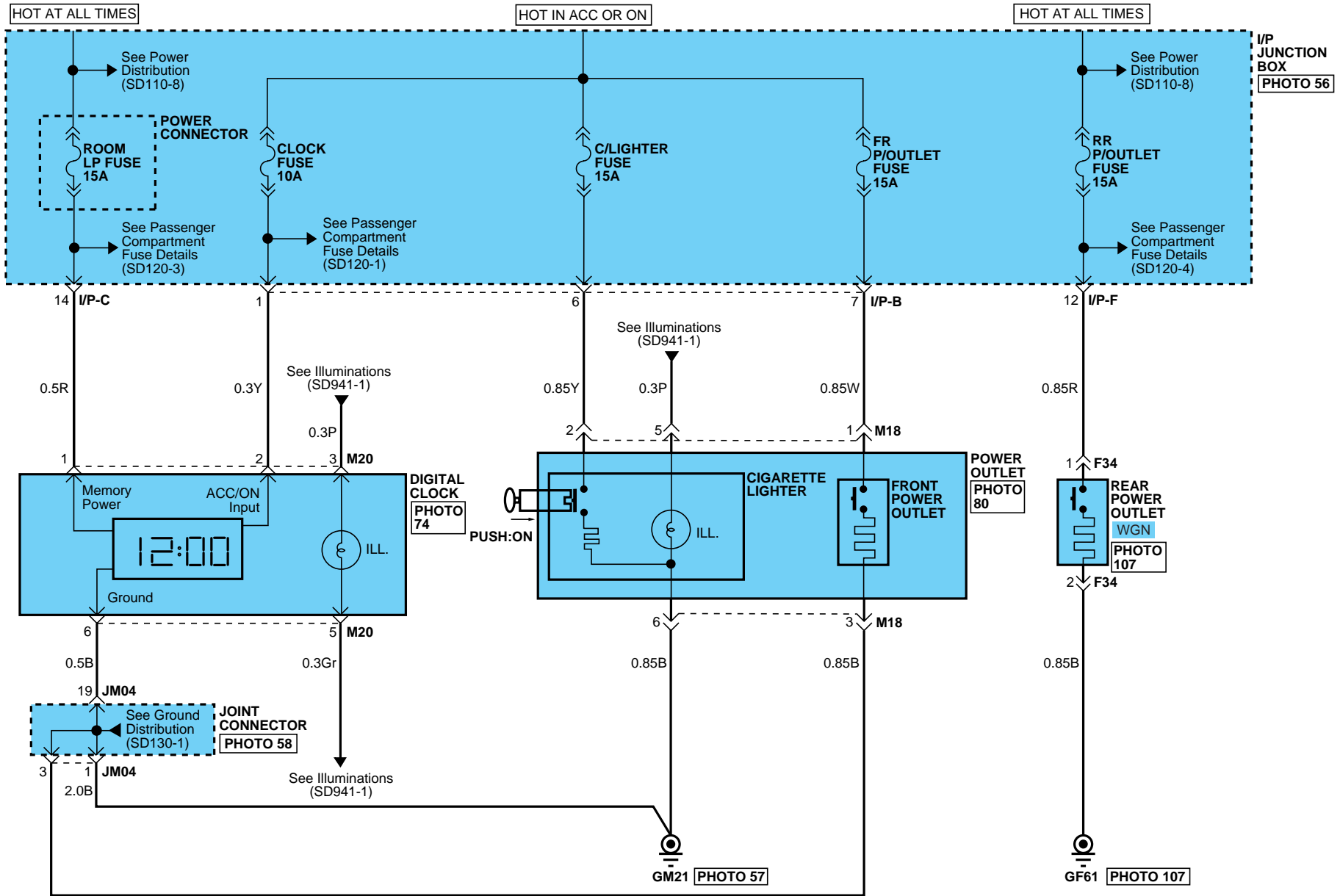

DIGITAL CLOCK & CIGARETTE LIGHTER (POWER OUTLET)

DIGITAL CLOCK & CIGARETTE LIGHTER (POWER OUTLET) (2)

SD945-2

M18

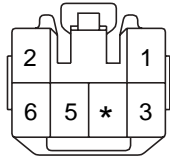

KET_090II_06F_W

M20

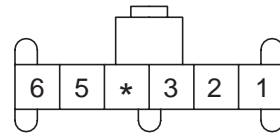

KET_91A_06F_W

F34

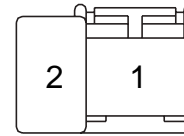

AMP_PLM2_02F_B_DL

BLANK

BCM (BODY CONTROL MODULE) SYSTEM (1)

SD950-1

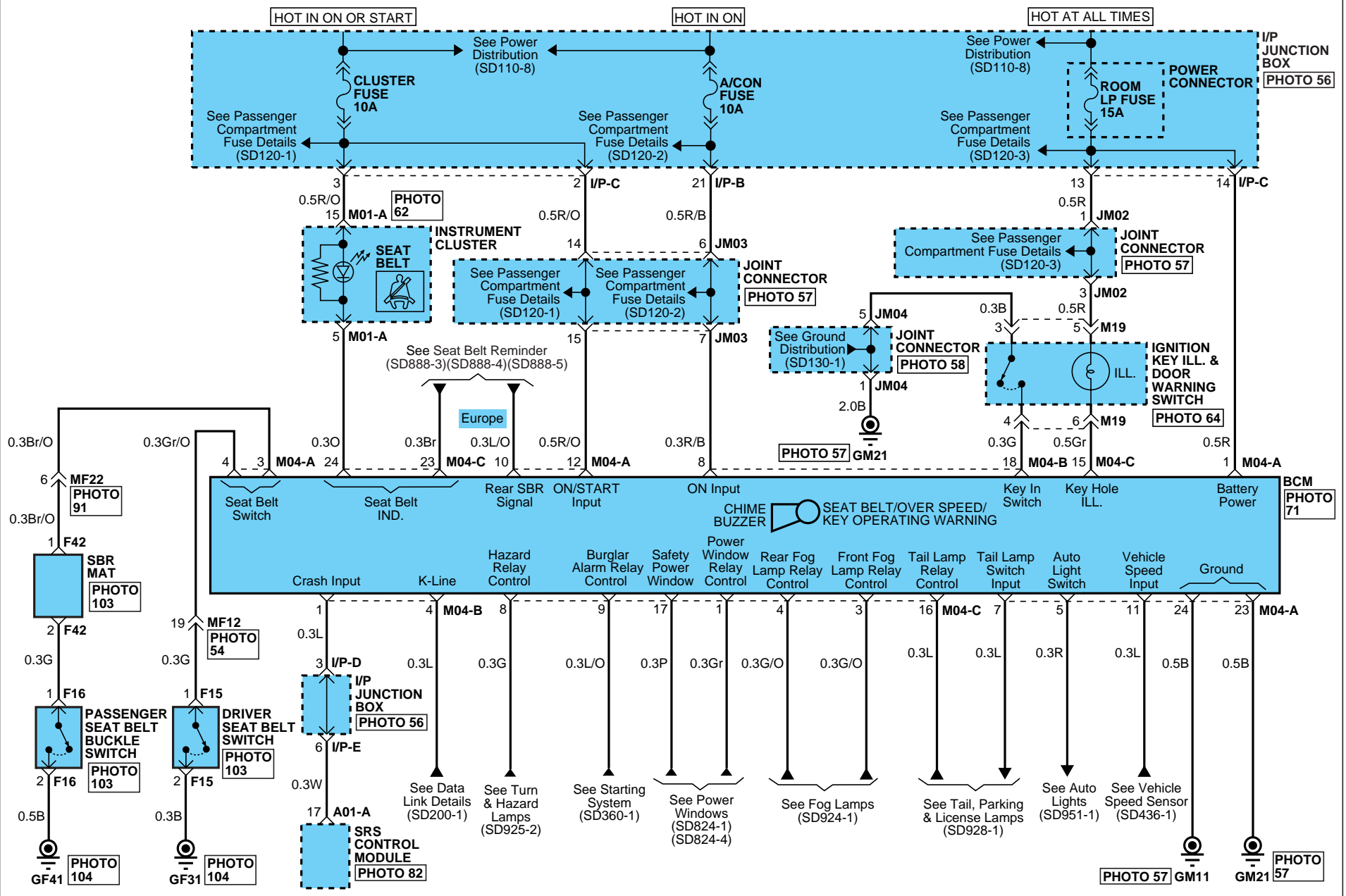

BCM (BODY CONTROL MODULE) SYSTEM

BCM (BODY CONTROL MODULE) SYSTEM (2)

SD950-2

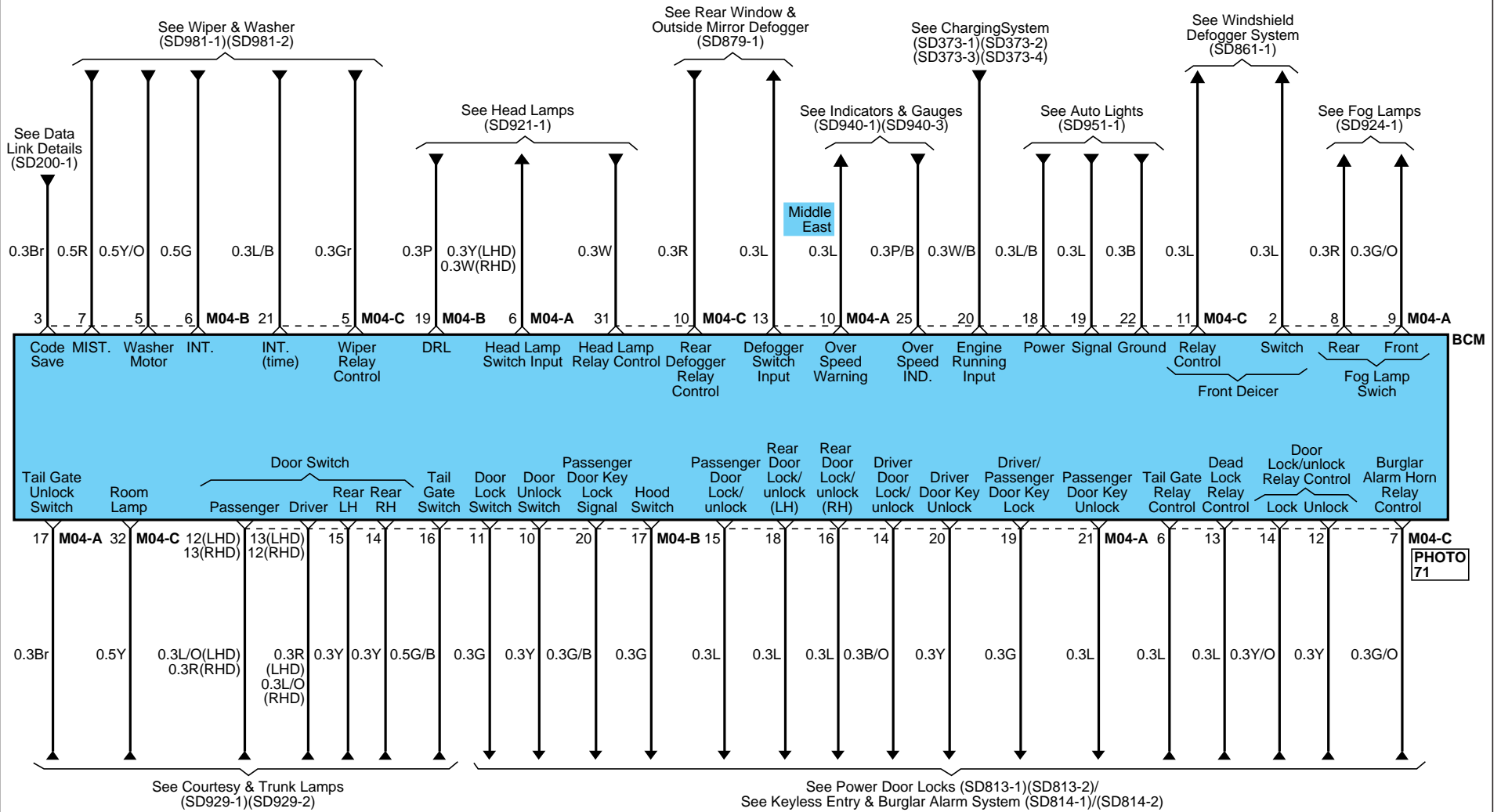

BCM (BODY CONTROL MODULE) SYSTEM

BCM (BODY CONTROL MODULE) SYSTEM (3)

SD950-3

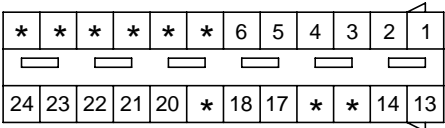
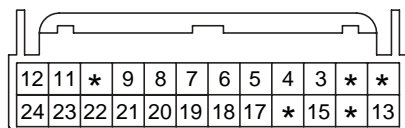
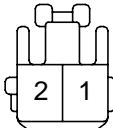
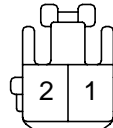
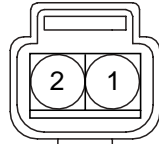
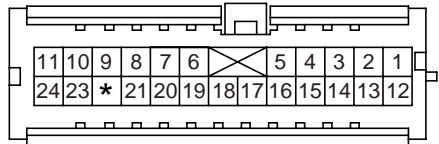
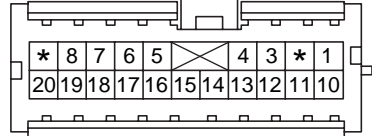
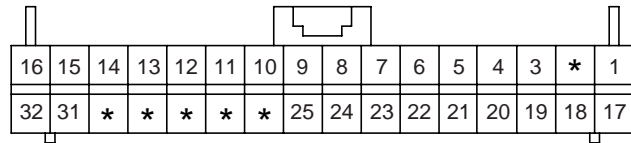
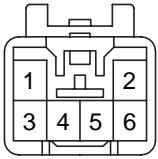
<p>A01-A</p>  <p>AMP_ABG_24F_B_ECU</p>	<p>M01-A</p>  <p>AMP_025_24F_W</p>	<p>F15</p>  <p>KET_090II_02F_W_L</p>	<p>F16</p>  <p>KET_090II_02F_W_L</p>
<p>F42</p>  <p>AMP_MQSWP_02F_B</p>	<p>M04-A</p>  <p>AMP_040III_24F_W</p>	<p>M04-B</p>  <p>AMP_040III_20F_W</p>	<p>BLANK</p>
<p>M04-C</p>  <p>AMP_025_32F_W</p>		<p>M19</p>  <p>KET_090II_06M_W</p>	<p>BLANK</p>
<p>BLANK</p>			

BCM (BODY CONTROL MODULE) SYSTEM

BCM (BODY CONTROL MODULE) SYSTEM (4)

SD950-4

MEMO

AUTO LIGHTS (1)

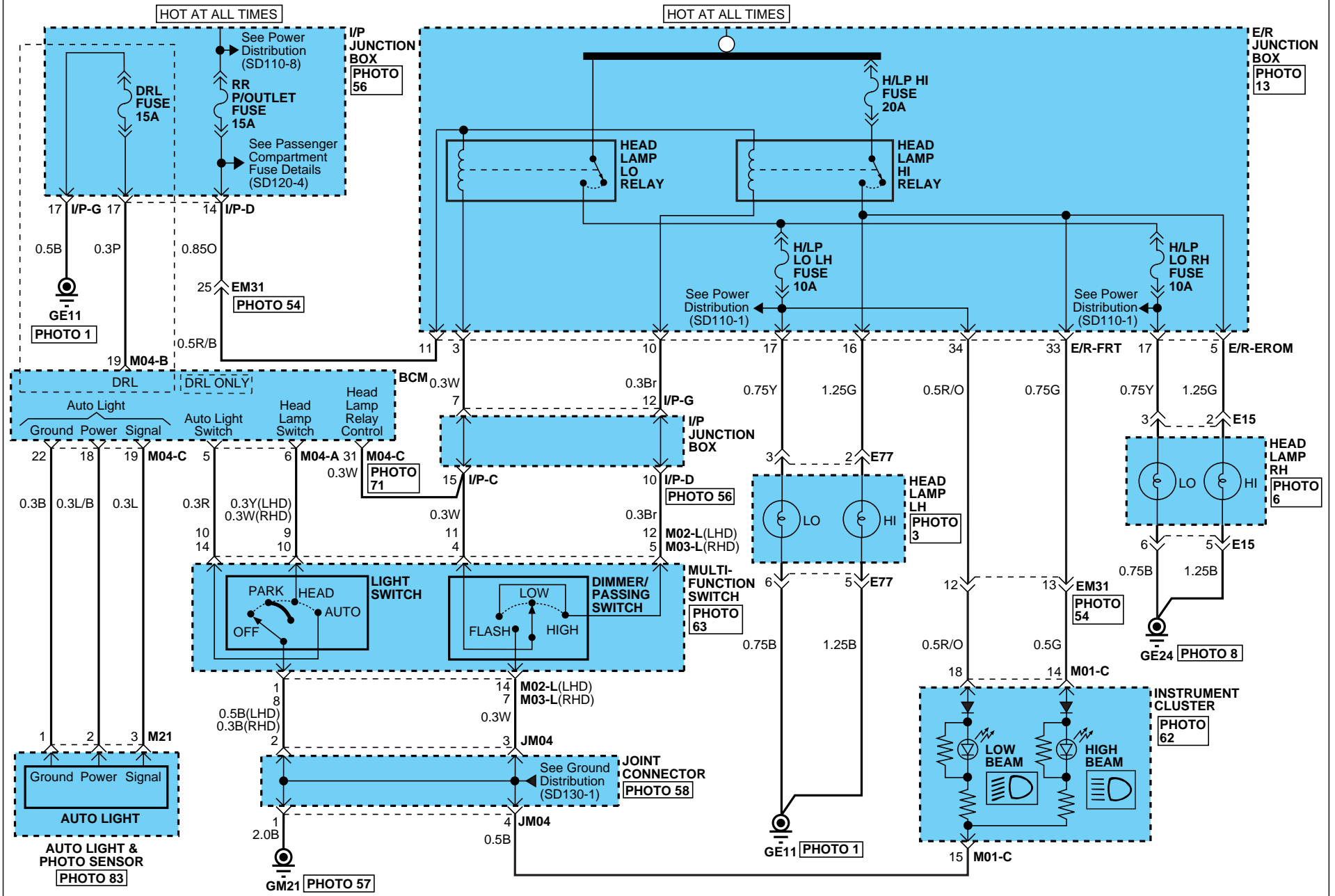

AUTO LIGHTS

AUTO LIGHTS (2)

SD951-2

E15

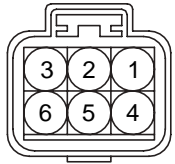

KUM_NMWP_06F_B

E77

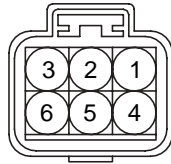

KUM_NMWP_06F_B

M01-C

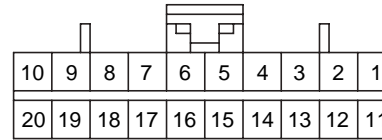

AMP_040M2_20F_B

M02-L

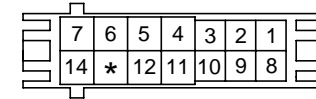

AMP_0409_14F_W

M03-L

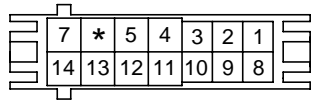

AMP_0409_14F_W

M04-A

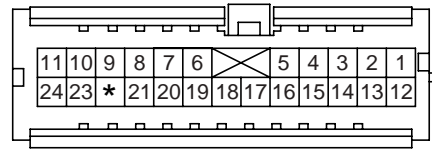

AMP_040III_24F_W

M04-B

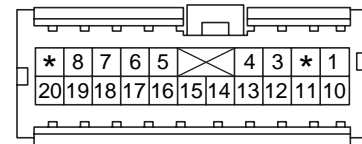

AMP_040III_20F_W

BLANK

M04-C

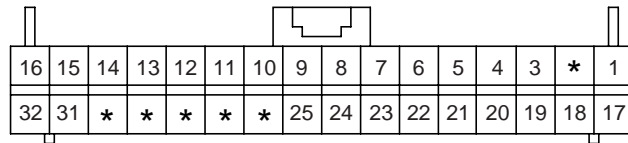

AMP_025_32F_W

M21

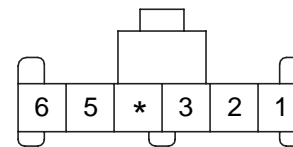

KET_91A_06F_W

BLANK

IMMOBILIZER CONTROL SYSTEM (1)

SD954-1

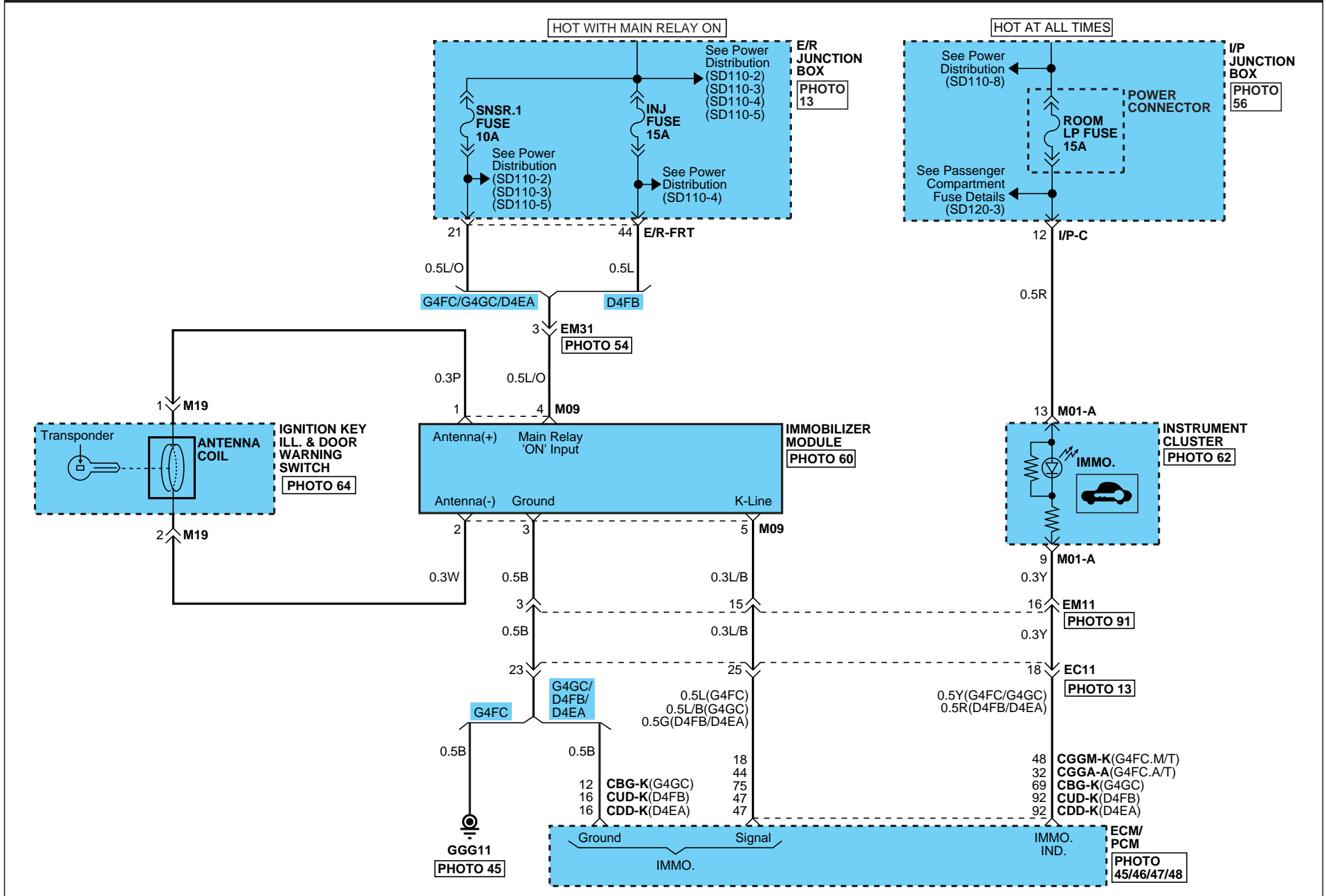

IMMOBILIZER CONTROL SYSTEM

IMMOBILIZER CONTROL SYSTEM (2)

SD954-2

CGGA-A

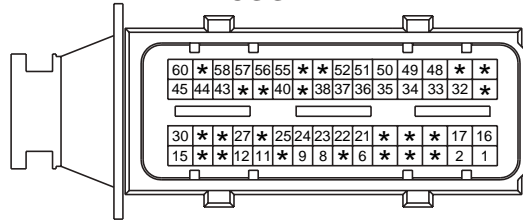

AMP_ECU_60F_B

CGGM-K

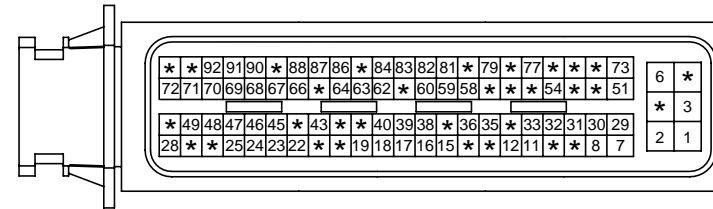

AMP_ECU_94F_B

CBG-K

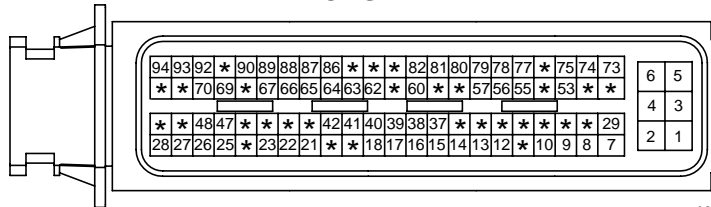

AMP_ECU_94F_B

CUD-K

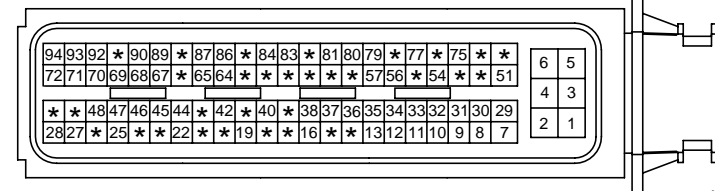

AMP_ECU_94F_B

CDD-K

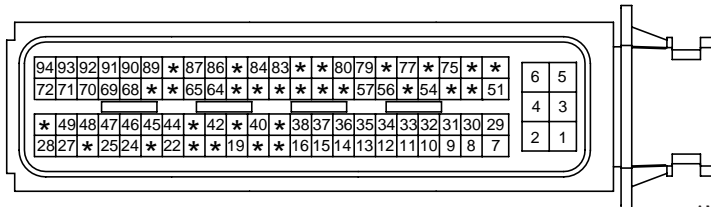

AMP_ECU_94F_B

M01-A

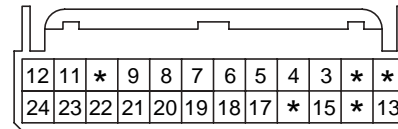

AMP_025_24F_W

M09

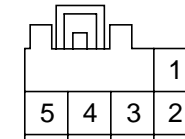

KUM_CDR_05F_W

M19

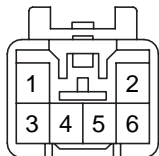

KET_090II_06M_W

BLANK

BLANK

BLANK

TIRE PRESSURE MONITORING SYSTEM (1)

SD956-1

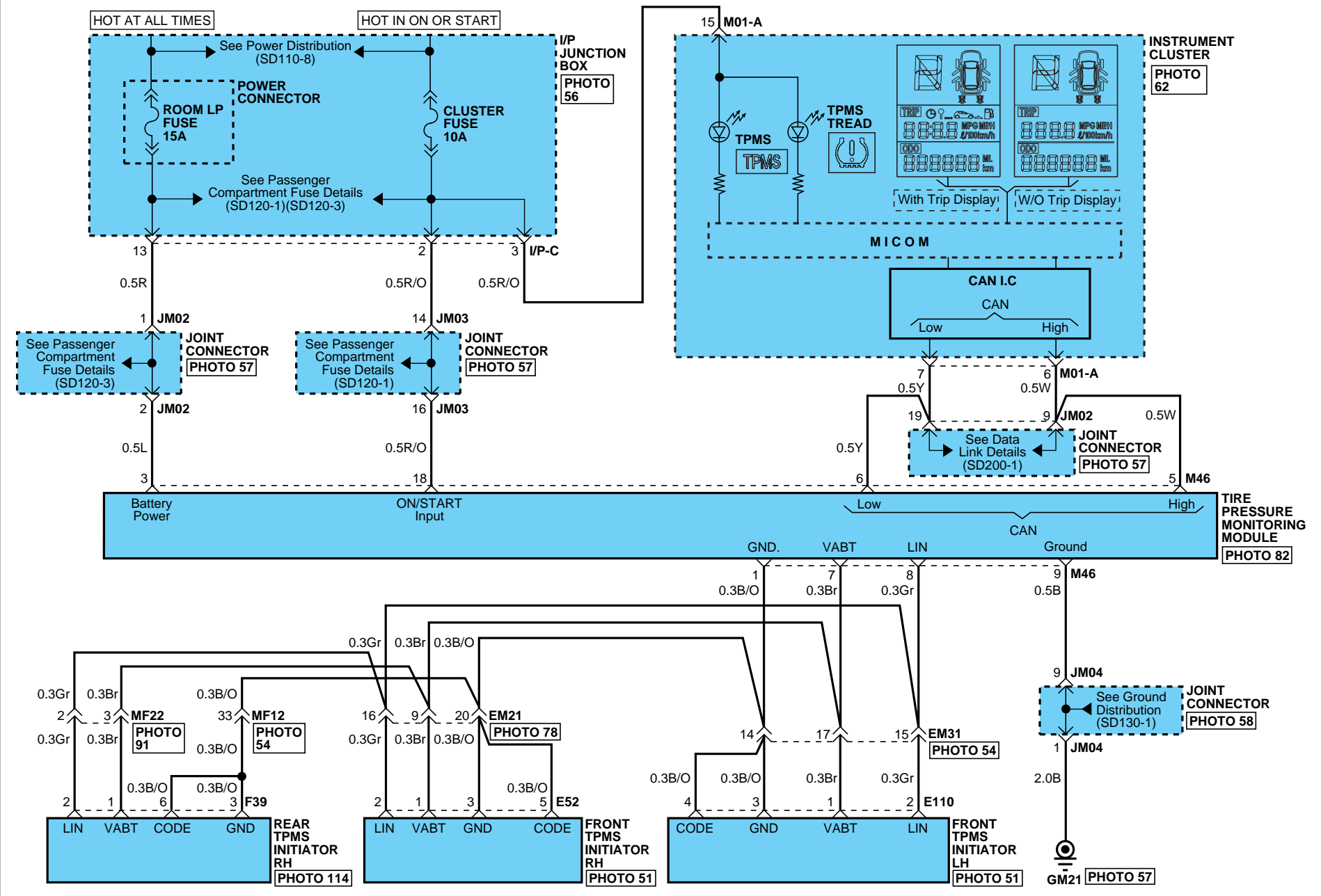

TIRE PRESSURE MONITORING SYSTEM

TIRE PRESSURE MONITORING SYSTEM (2)

SD956-2

E52

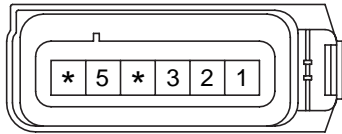

AMP_025_06F_B

E110

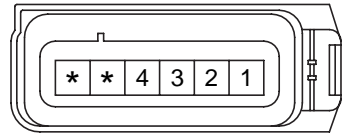

AMP_025_06F_B

F39

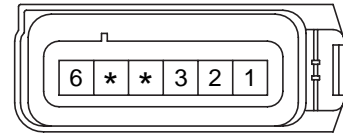

AMP_025_06F_B

M01-A

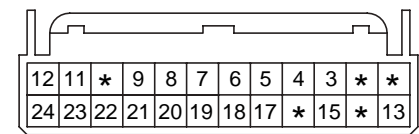

AMP_025_24F_W

M46

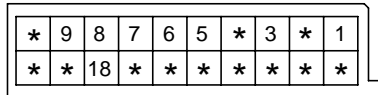

AMP_MQS_20F_B_GH

BLANK

BLANK

BLANK

REAR PARKING ASSIST SYSTEM (1)

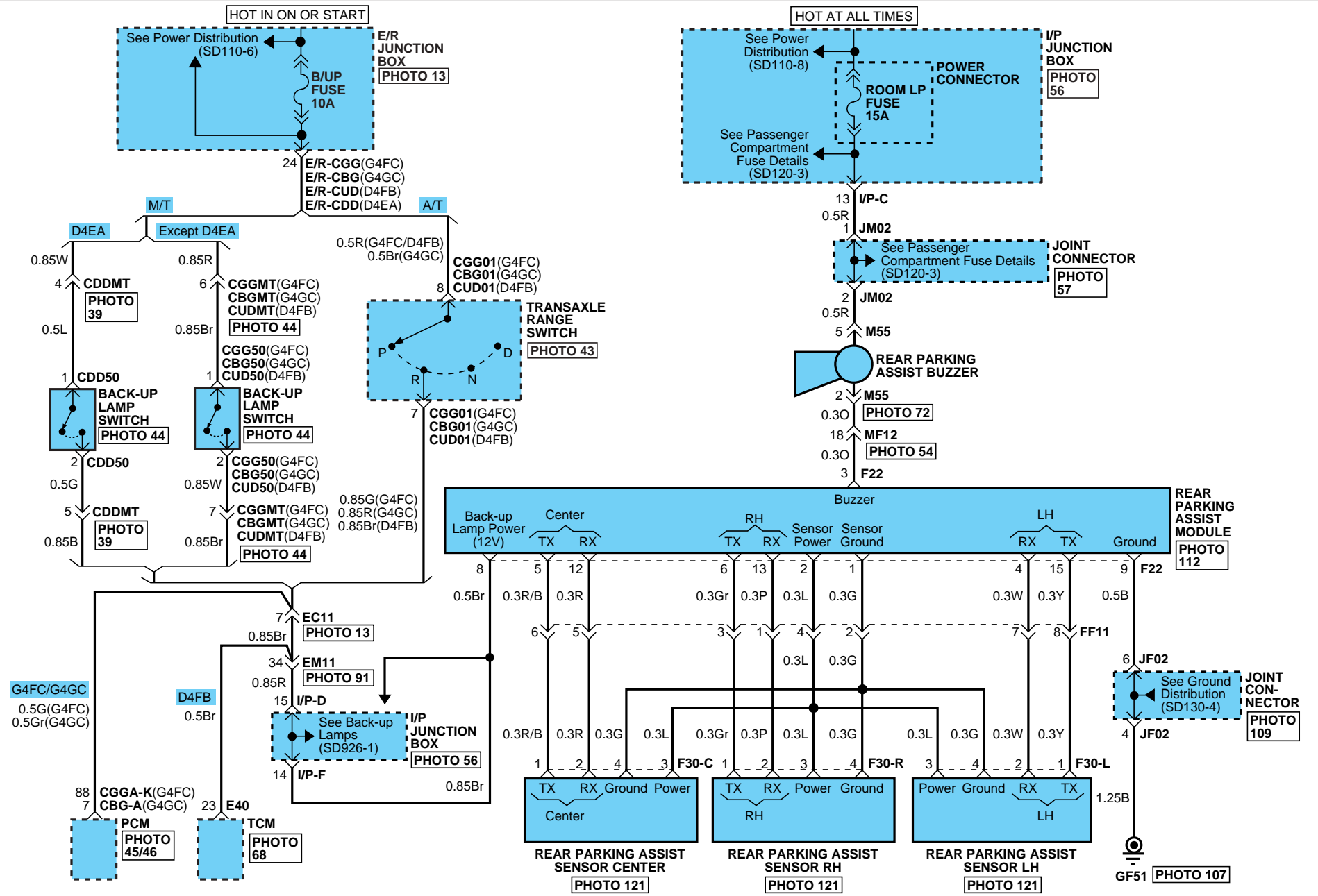

REAR PARKING ASSIST SYSTEM

REAR PARKING ASSIST SYSTEM (2)

SD957-2

CGGA-K

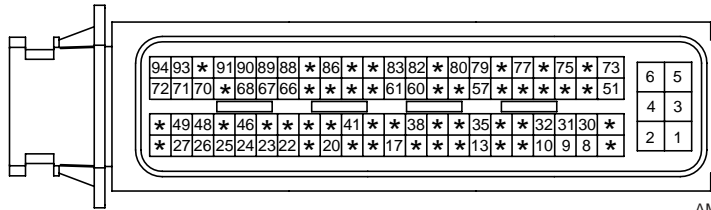

AMP_ECU_94F_B

CBG-A

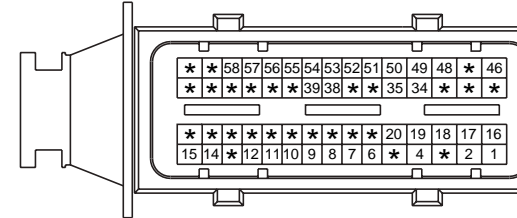

AMP_ECU_60F_B

CGG01



KET_SSD_10F_B_A

CGG50

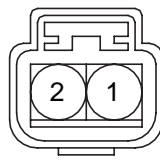

KUM_NMWP_02F_LGr

CBG01



KET_SSD_01F_B_A

CBG50

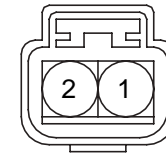

KUM_NMWP_02F_LGr

CUD01

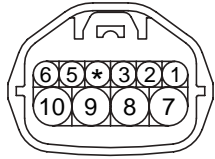

KET_SSD_10F_B_A

CUD50

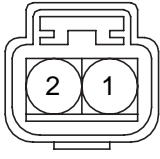

KUM_NMWP_02F_LGr

CDD50

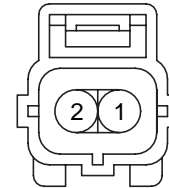

AMP_EJ_MK_II_2F

BLANK

E40

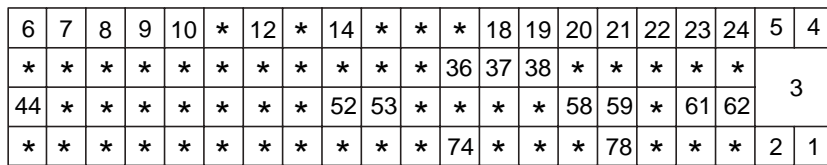

KET_ECU_81F_B_BOSCH

F22

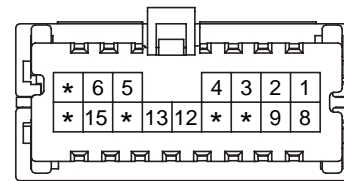

KET_040III_16F_W

F30-C



AMP_EJWP_04F_B

F30-L



AMP_EJWP_04F_B

F30-R



AMP_EJWP_04F_B

M55

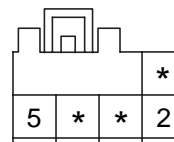

KUM_CDR_05F_W

BLANK

AUDIO SYSTEM (1)

SD961-1

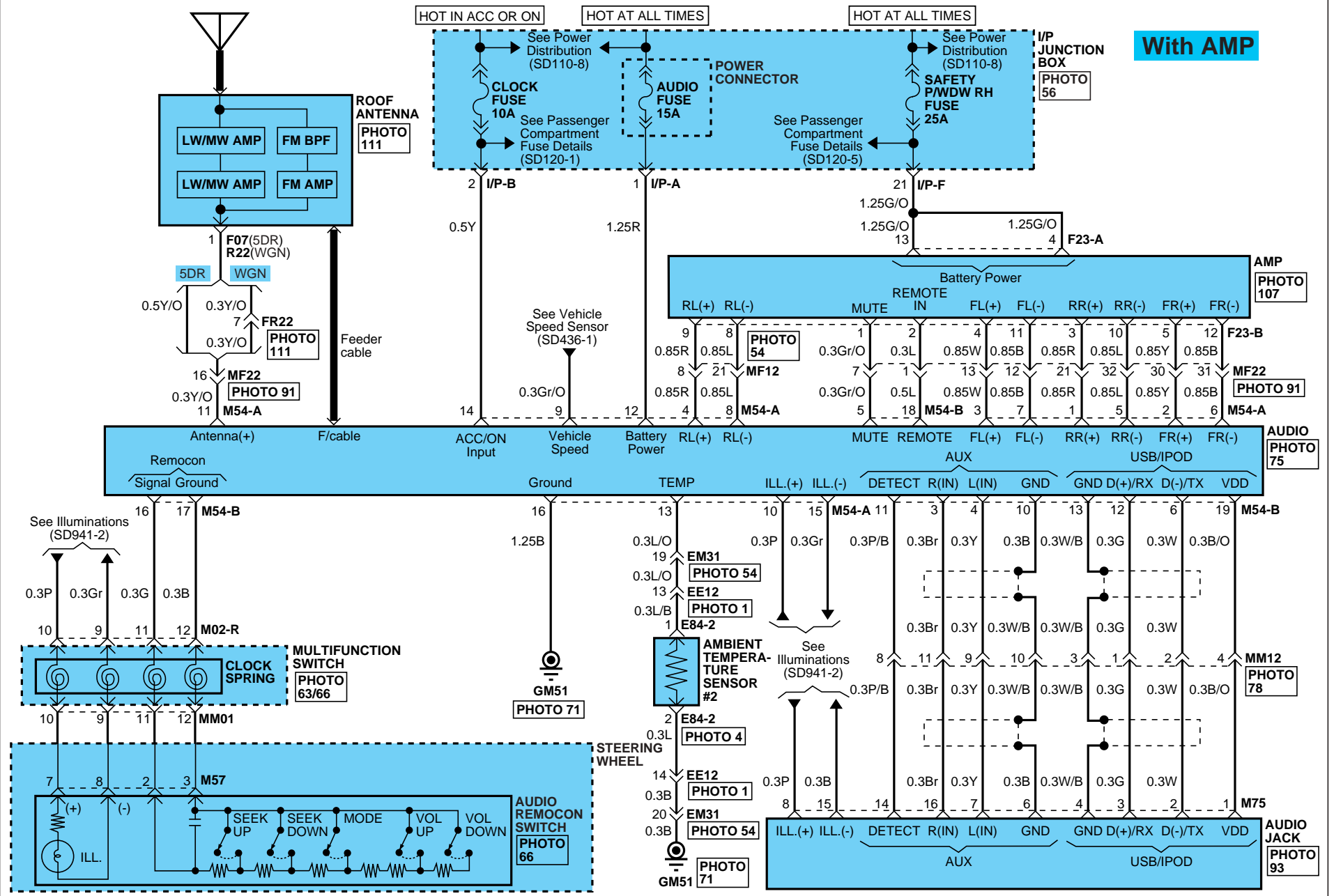

AUDIO SYSTEM

AUDIO SYSTEM (2)

SD961-2

With AMP

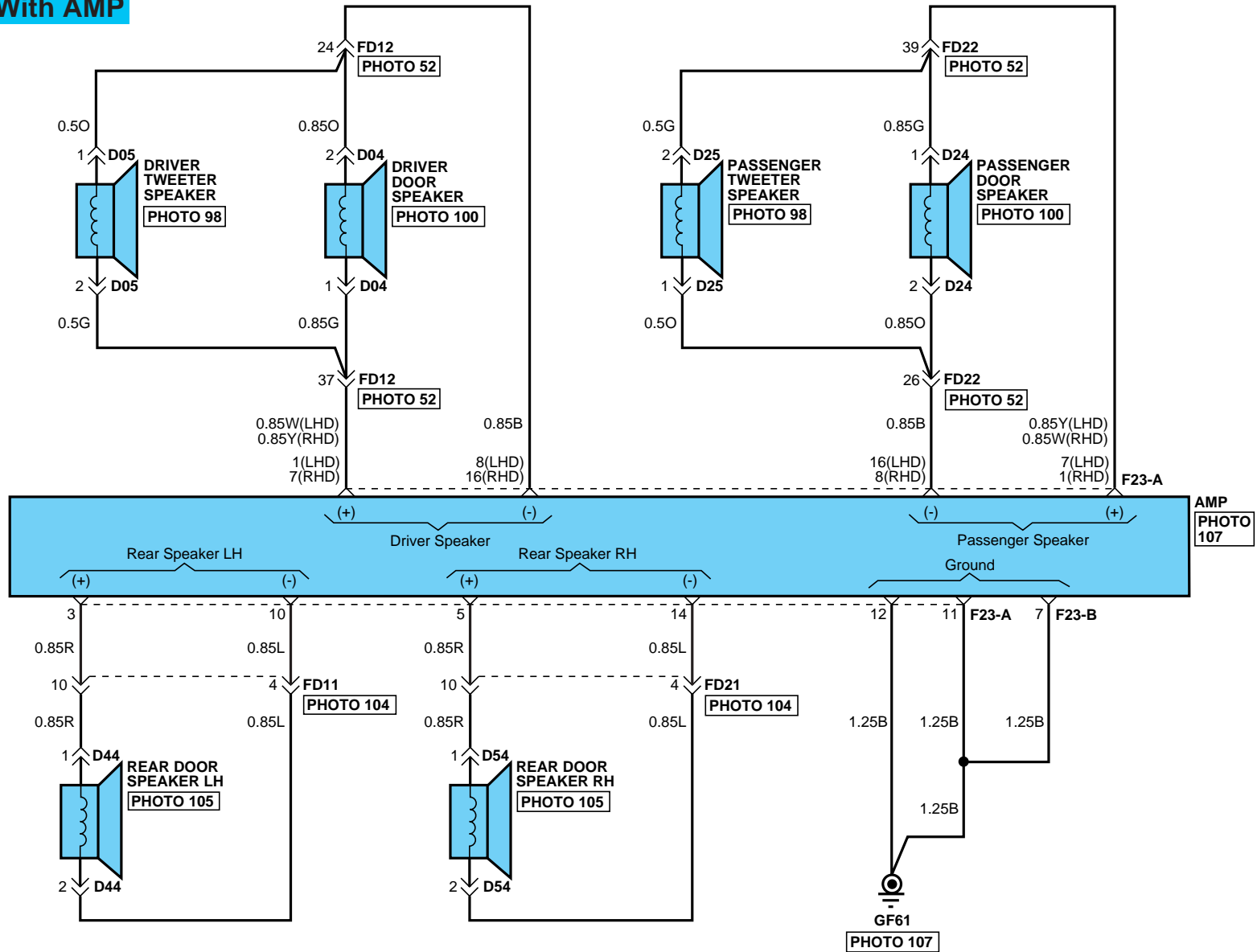

AUDIO SYSTEM

AUDIO SYSTEM (3)

SD961-3

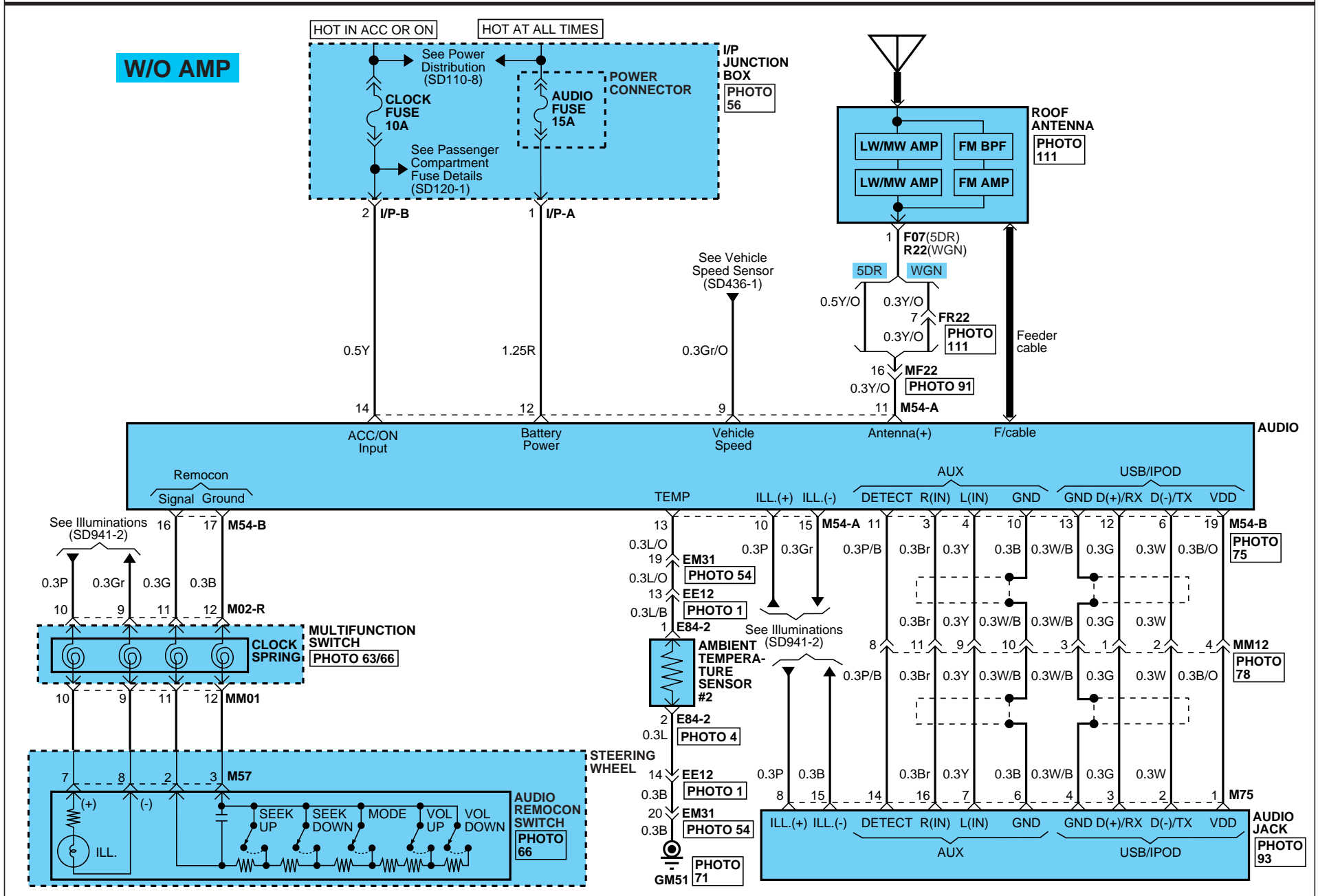

AUDIO SYSTEM

AUDIO SYSTEM (4)

SD961-4



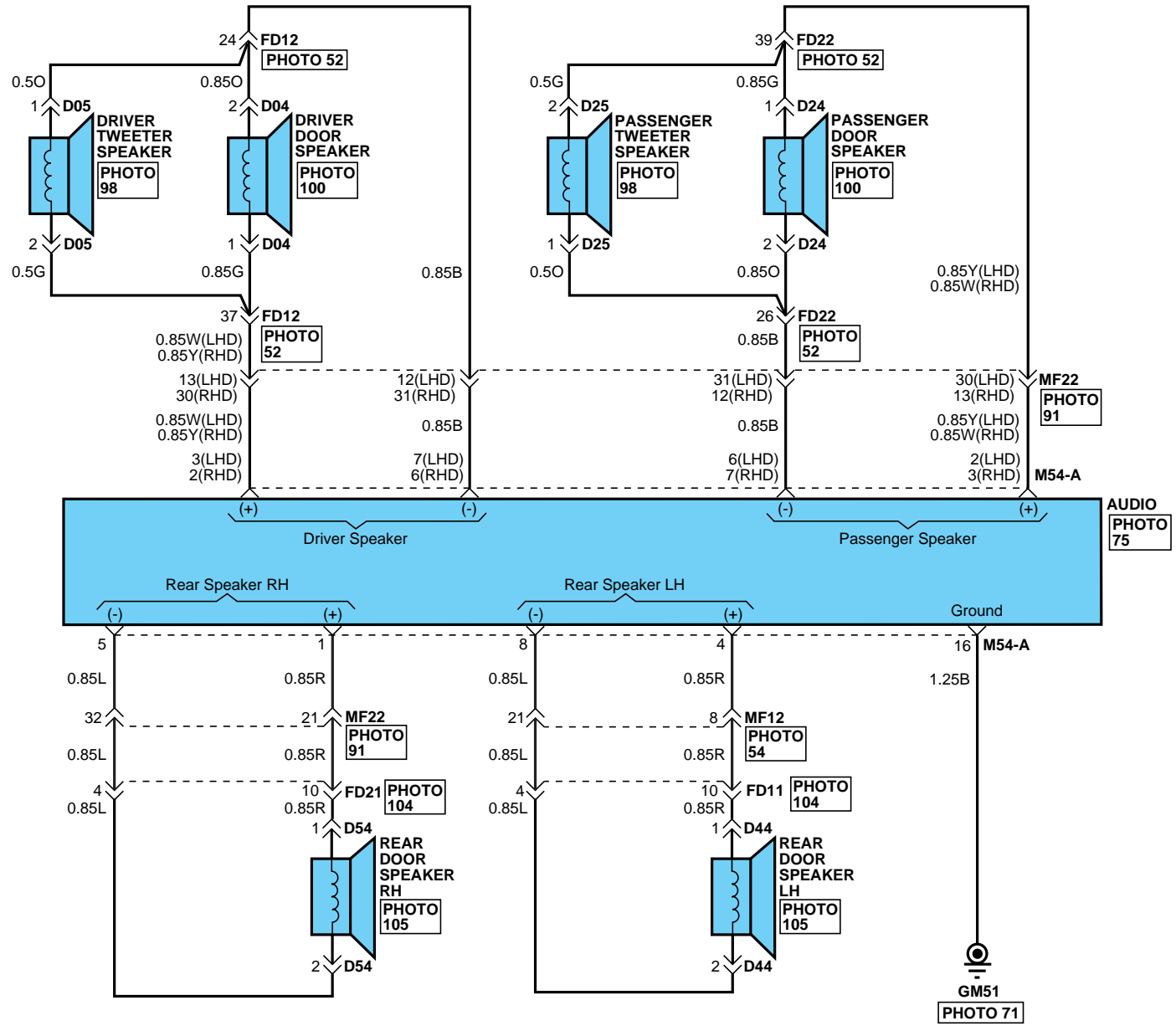

W/O AMP

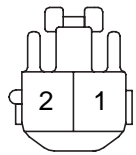
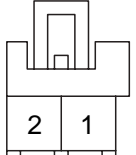
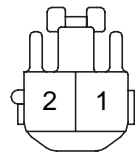
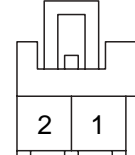
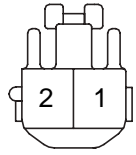
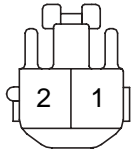
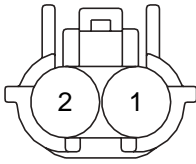

AUDIO SYSTEM

AUDIO SYSTEM (5)

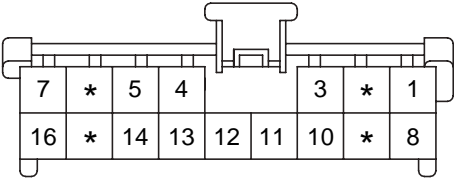
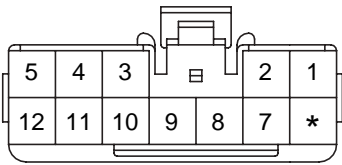
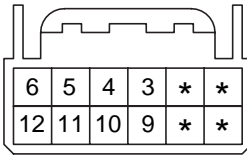
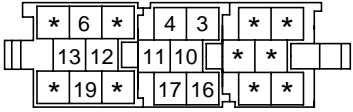
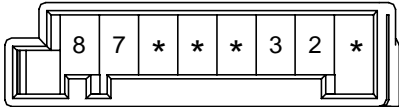
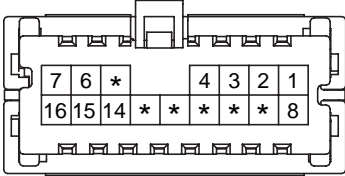
SD961-5

<p>D04</p>  <p>KET_090II_02F_W_L</p>	<p>D05</p>  <p>KUM_CDR_02F_W</p>	<p>D24</p>  <p>KET_090II_02F_W_L</p>	<p>D25</p>  <p>KUM_CDR_02F_W</p>																
<p>D44</p>  <p>KET_090II_02F_W_L</p>	<p>D54</p>  <p>KET_090II_02F_W_L</p>	<p>E84-2</p>  <p>KET_SWP_02F_B</p>	<p>F07</p>  <p>AMP_PLM1_01F_B</p>																
<p>F23-A</p>  <p>KUM_AR_16F_B</p>	<p>F23-B</p>  <p>KET_090II_12F_W</p>	<p>M02-R</p>  <p>AMP_025_12F_W</p>	<p>M54-A</p> <table border="1" data-bbox="1742 810 1906 943"> <tr><td>4</td><td>3</td><td>2</td><td>1</td></tr> <tr><td>8</td><td>7</td><td>6</td><td>5</td></tr> <tr><td>12</td><td>11</td><td>10</td><td>9</td></tr> <tr><td>16</td><td>15</td><td>14</td><td>13</td></tr> </table> <p>CWB_CY_16F_B</p>	4	3	2	1	8	7	6	5	12	11	10	9	16	15	14	13
4	3	2	1																
8	7	6	5																
12	11	10	9																
16	15	14	13																
<p>M54-B</p>  <p>CWB_CY_20F_R</p>	<p>M57</p>  <p>CR08F068</p>	<p>M75</p>  <p>KET_040III_16F_W</p>	<p>R22</p>  <p>AMP_PLM1_01F_B</p>																
Empty space for additional diagrams																			

AUDIO SYSTEM

AUDIO SYSTEM (6)

SD961-6

MEMO

CRUISE CONTROL SYSTEM (1)

SD964-1

G4GC ONLY

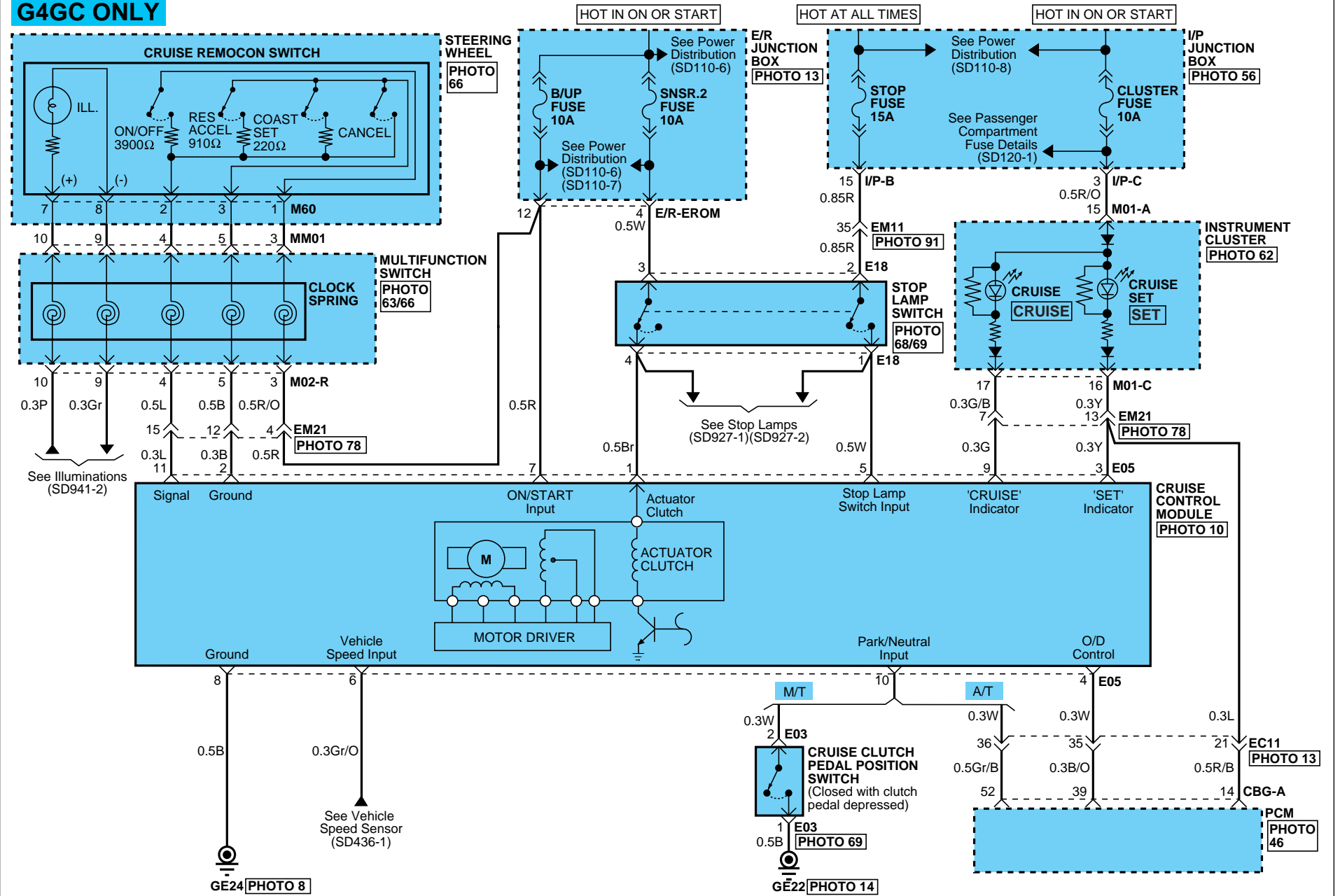

CRUISE CONTROL SYSTEM

CRUISE CONTROL SYSTEM (2)

SD964-2

CBG-A

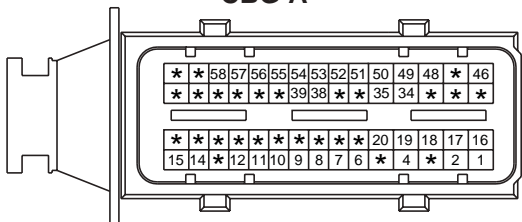

AMP_ECU_60F_B

E03



KET_250DL_02F_W

E05

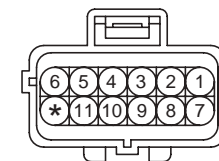

AMP_EJWP_12F_B

E18

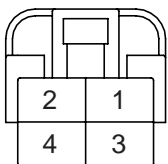

KET_250DL_04F_W

M01-A

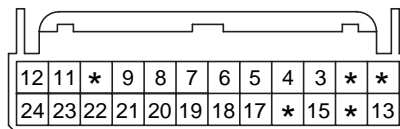

AMP_025_24F_W

M01-C

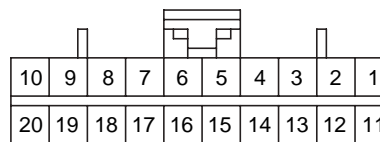

AMP_040M2_20F_B

M02-R

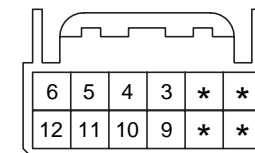

AMP_025_12F_W

M60

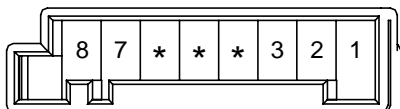

CR08F068

BLANK

BLANK

BLANK

NAVIGATION SYSTEM (1)

SD967-1

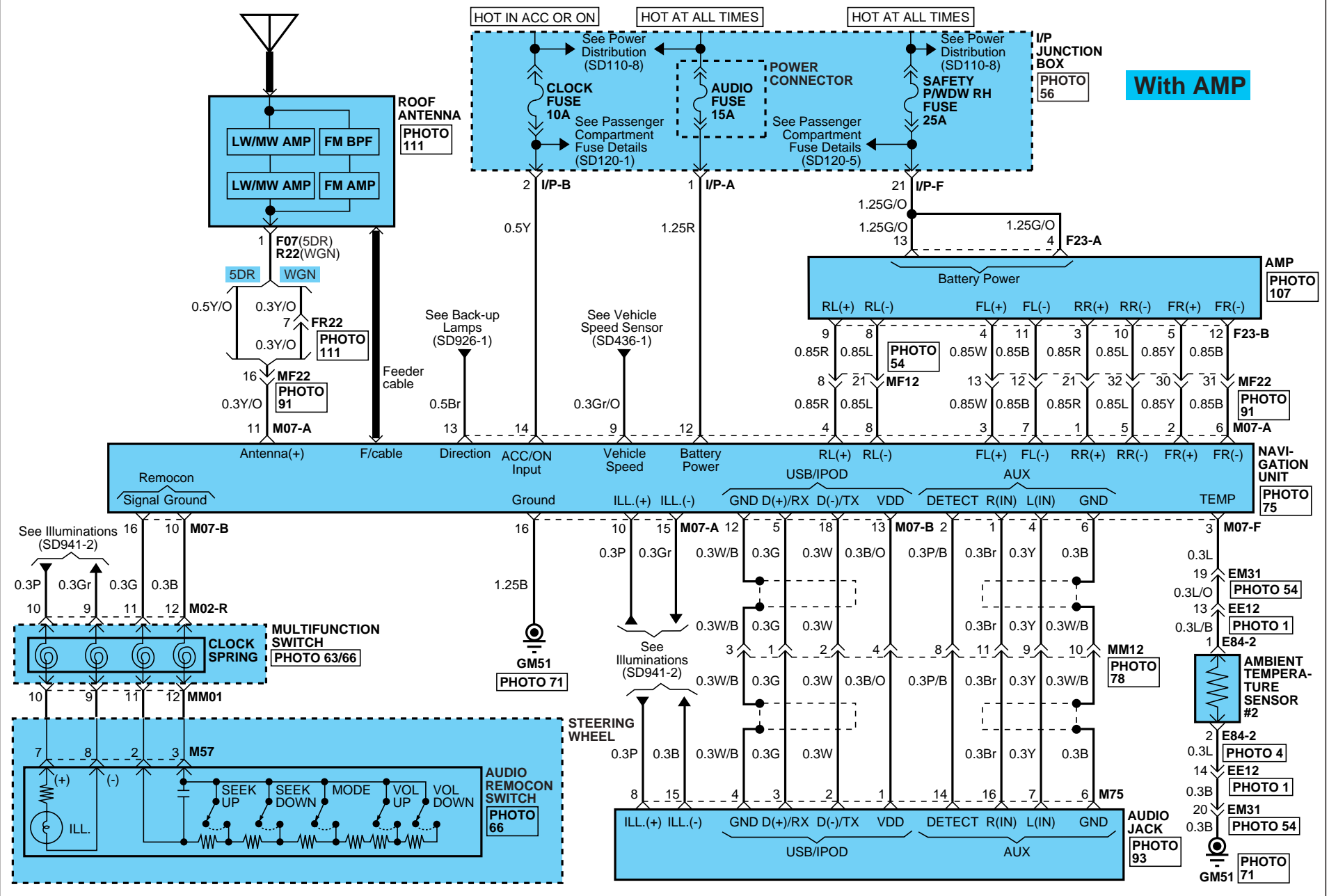

With AMP

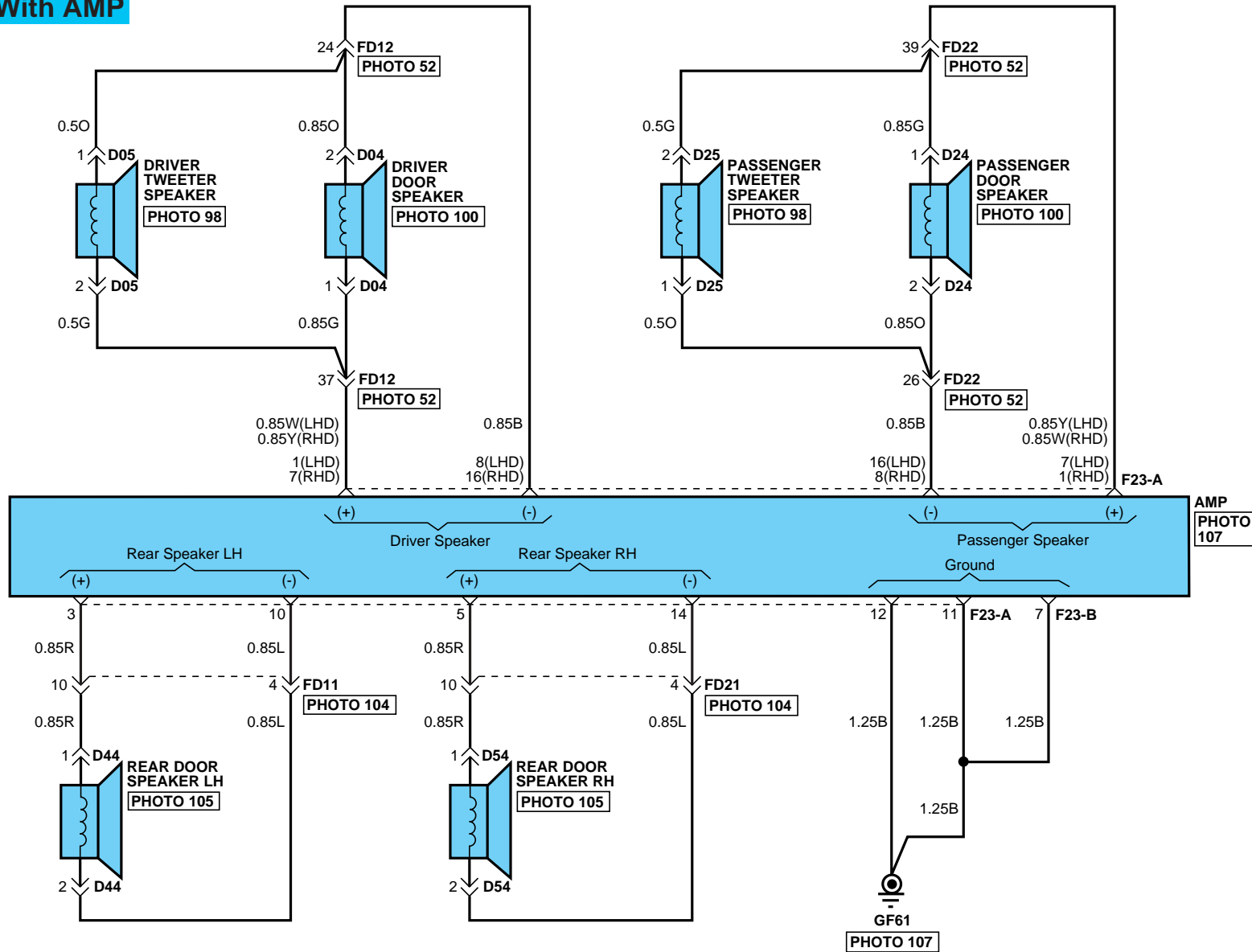

NAVIGATION SYSTEM

NAVIGATION SYSTEM (3)

SD967-3

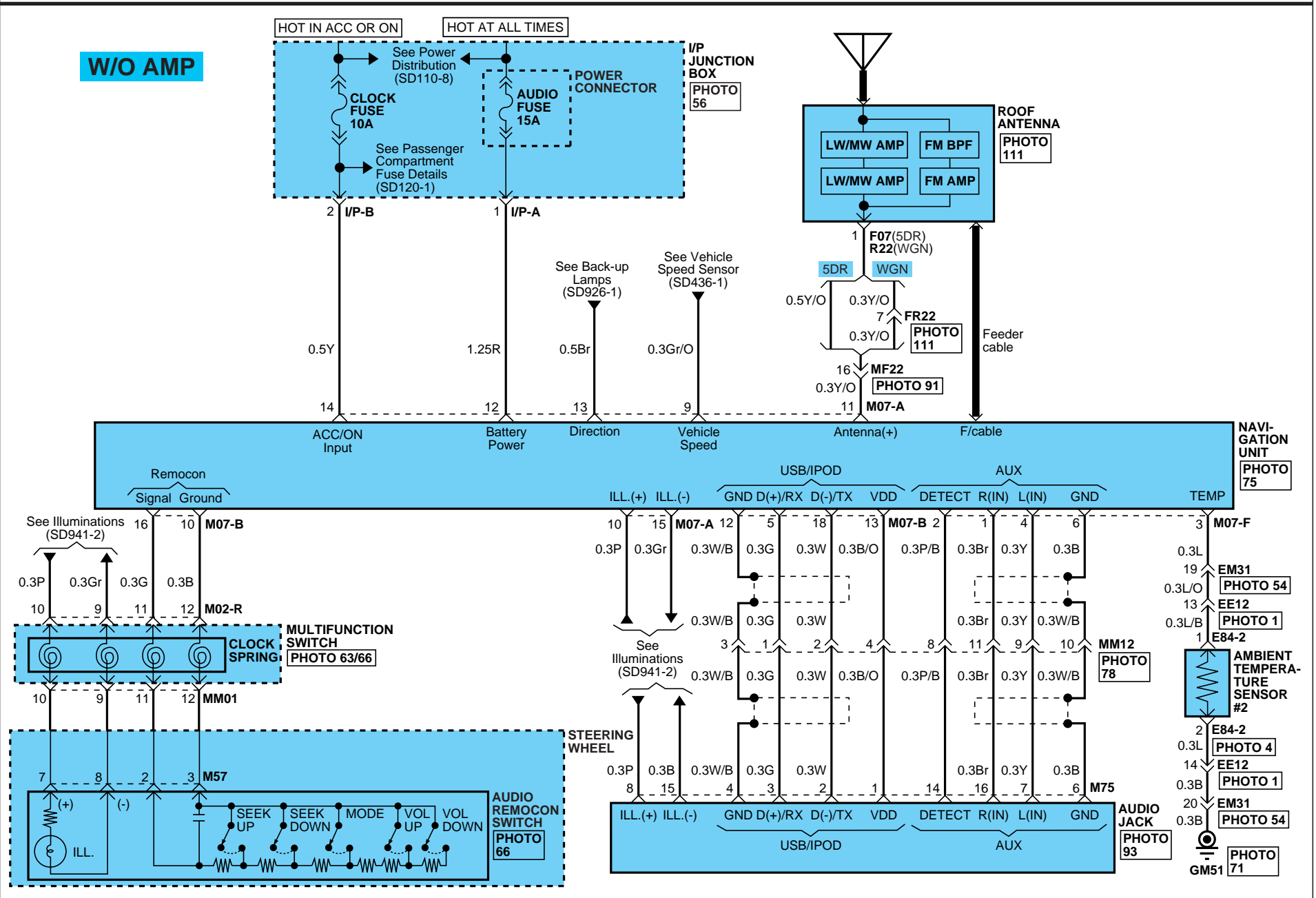



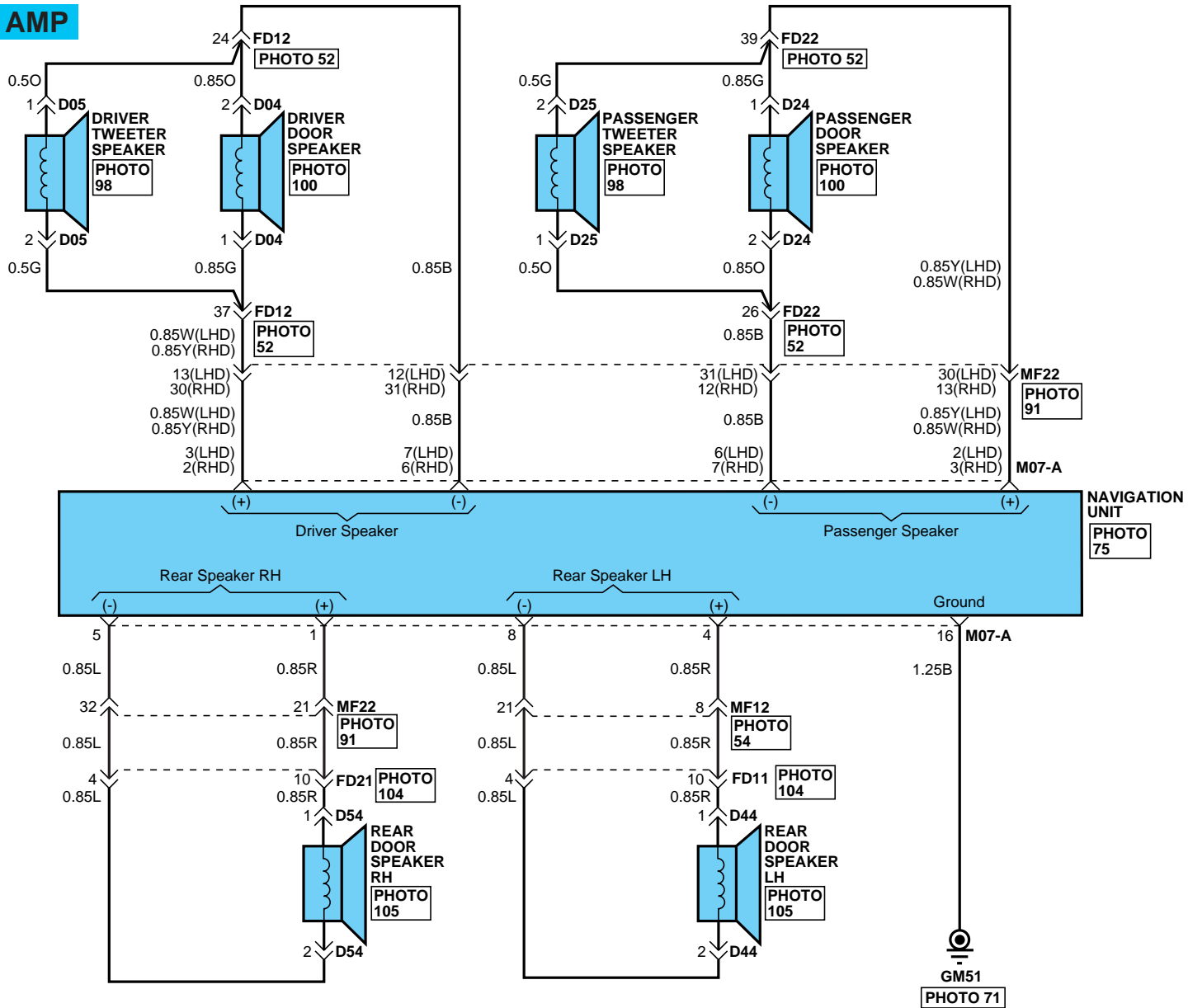

W/O AMP

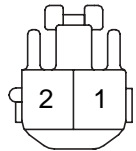
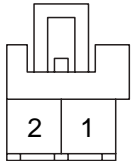
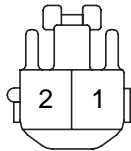
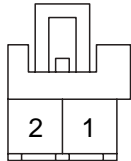
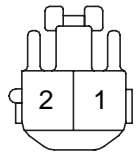
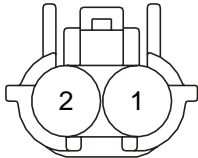

NAVIGATION SYSTEM

NAVIGATION SYSTEM (5)

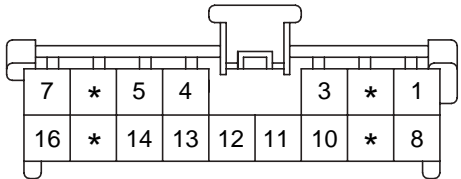
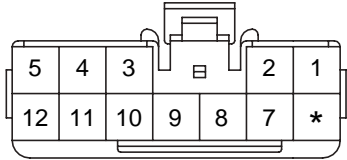
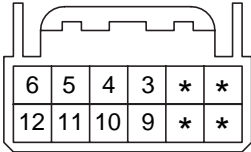
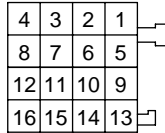
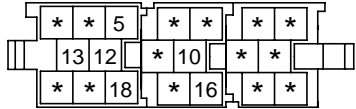
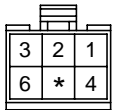
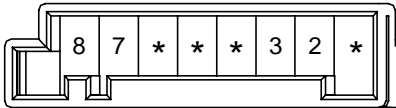
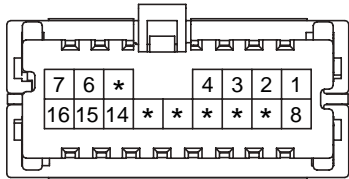
SD967-5

<p>D04</p>  <p>KET_090II_02F_W_L</p>	<p>D05</p>  <p>KUM_CDR_02F_W</p>	<p>D24</p>  <p>KET_090II_02F_W_L</p>	<p>D25</p>  <p>KUM_CDR_02F_W</p>
<p>D44/D54</p>  <p>KET_090II_02F_W_L</p>	<p>E84-2</p>  <p>KET_SWP_02F_B</p>	<p>F07</p>  <p>AMP_PLM1_01F_B</p>	<p>F23-A</p>  <p>KUM_AR_16F_B</p>
<p>F23-B</p>  <p>KET_090II_12F_W</p>	<p>M02-R</p>  <p>AMP_025_12F_W</p>	<p>M07-A</p>  <p>CWB_CY_16F_B</p>	<p>M07-B</p>  <p>CWB_CY_20F_R</p>
<p>M07-F</p>  <p>MLX_118_06F_B</p>	<p>M57</p>  <p>CR08F068</p>	<p>M75</p>  <p>KET_040III_16F_W</p>	<p>R22</p>  <p>AMP_PLM1_01F_B</p>

NAVIGATION SYSTEM

NAVIGATION SYSTEM (6)

SD967-6

MEMO

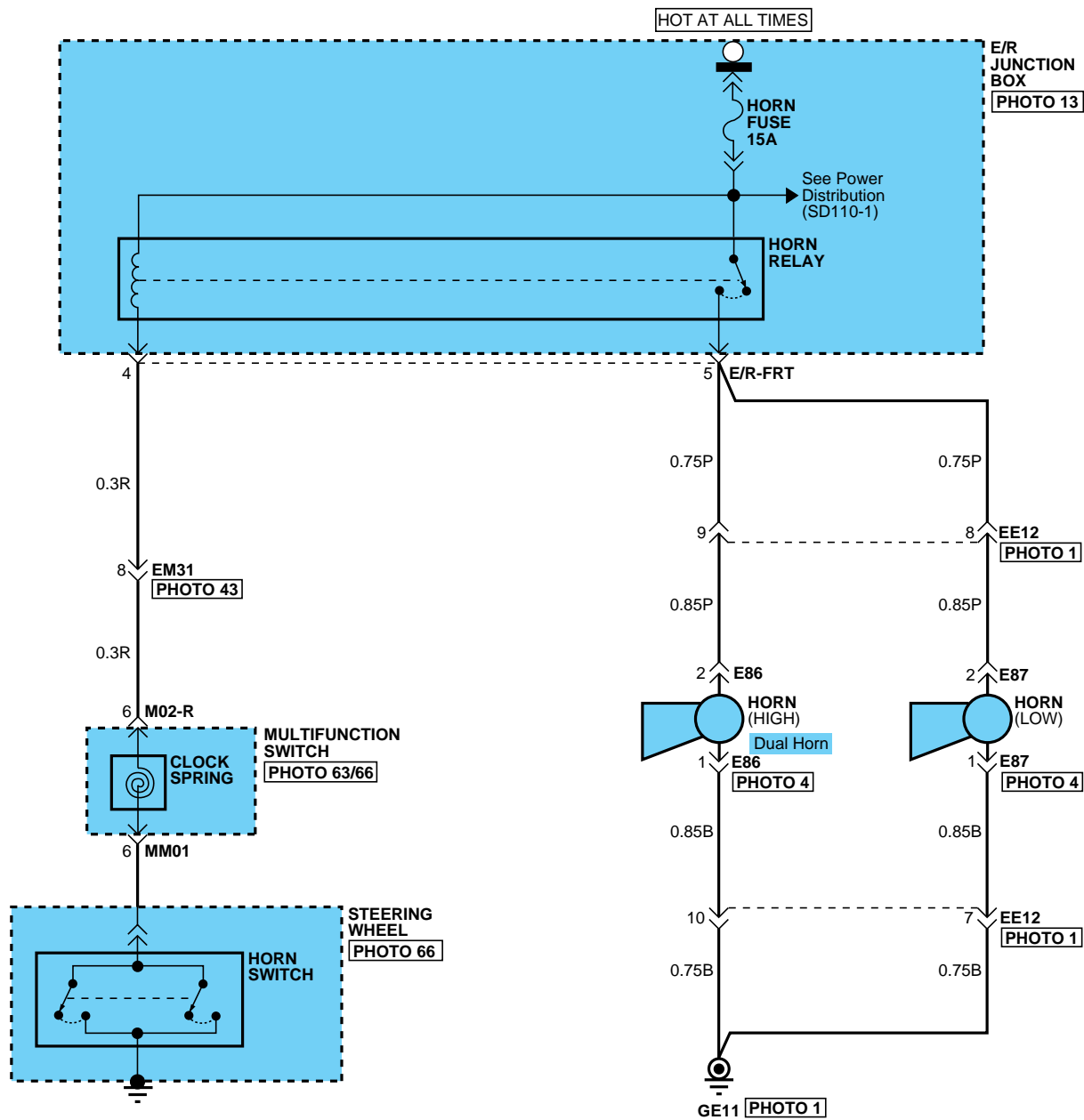

HORNS

HORNS (2)

SD968-2

E86

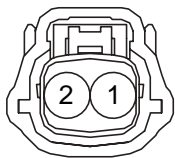

MLX_HORN_02F_B_FILT

E87

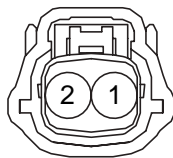

MLX_HORN_02F_B_FILT

M02-R

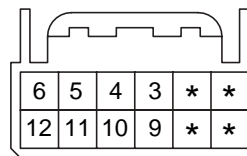

AMP_025_12F_W

BLANK

BLOWER & A/C CONTROLS (AUTO) (1)

SD971-1

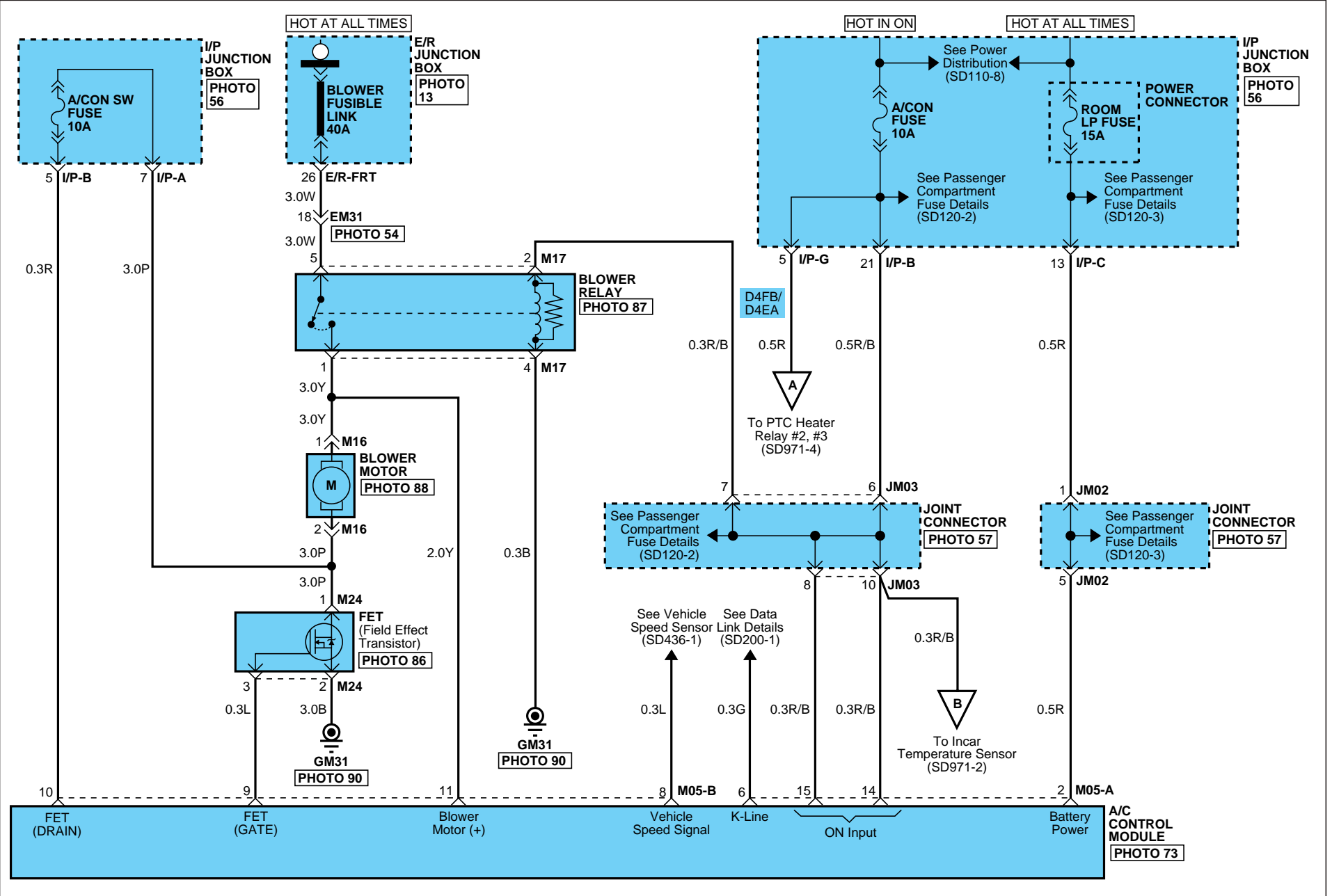

BLOWER & A/C CONTROLS

BLOWER & A/C CONTROLS (AUTO) (2)

SD971-2

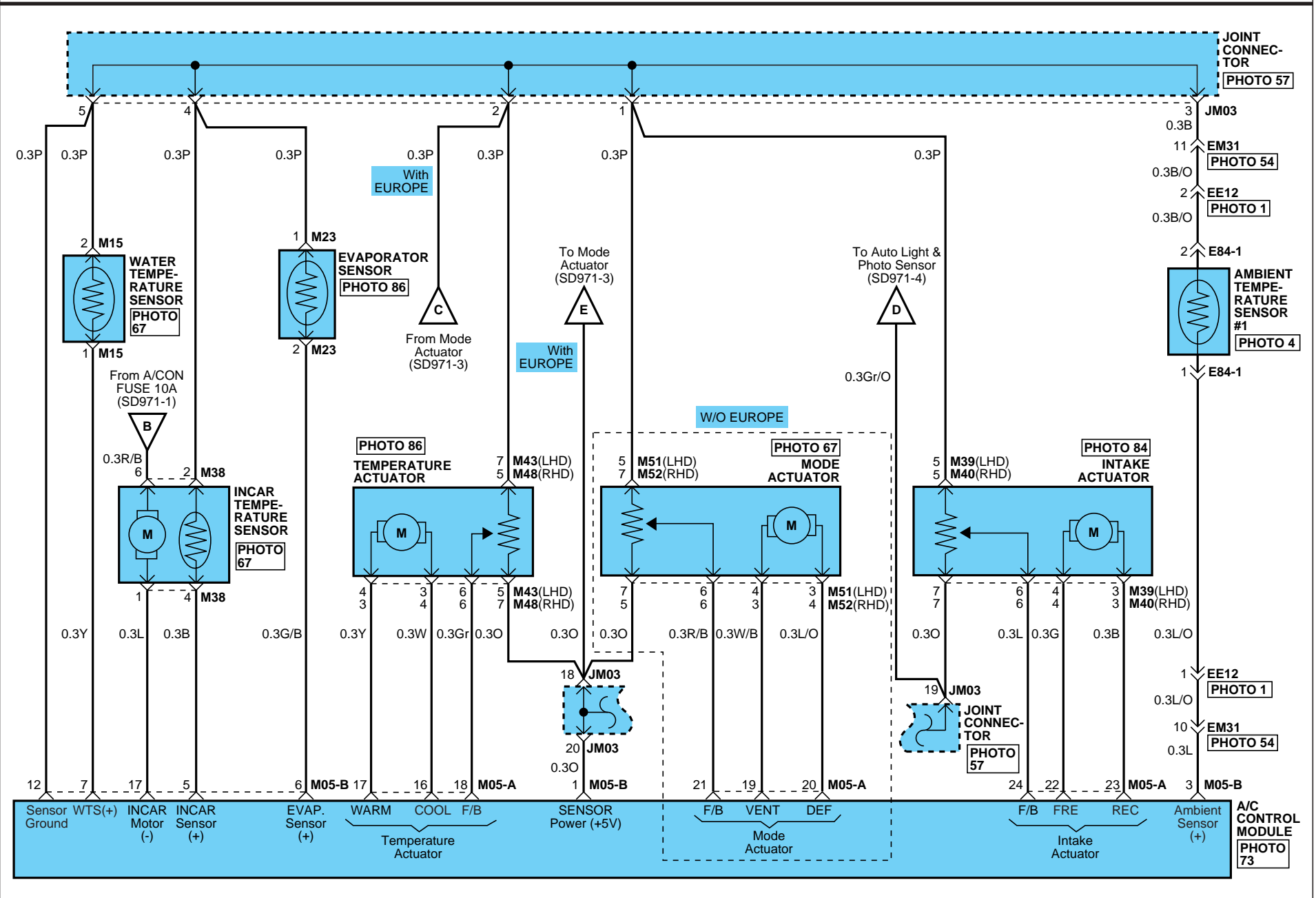

BLOWER & A/C CONTROLS

BLOWER & A/C CONTROLS (AUTO) (3)

SD971-3

With EUROPE

MODE ACTUATOR
PHOTO 67

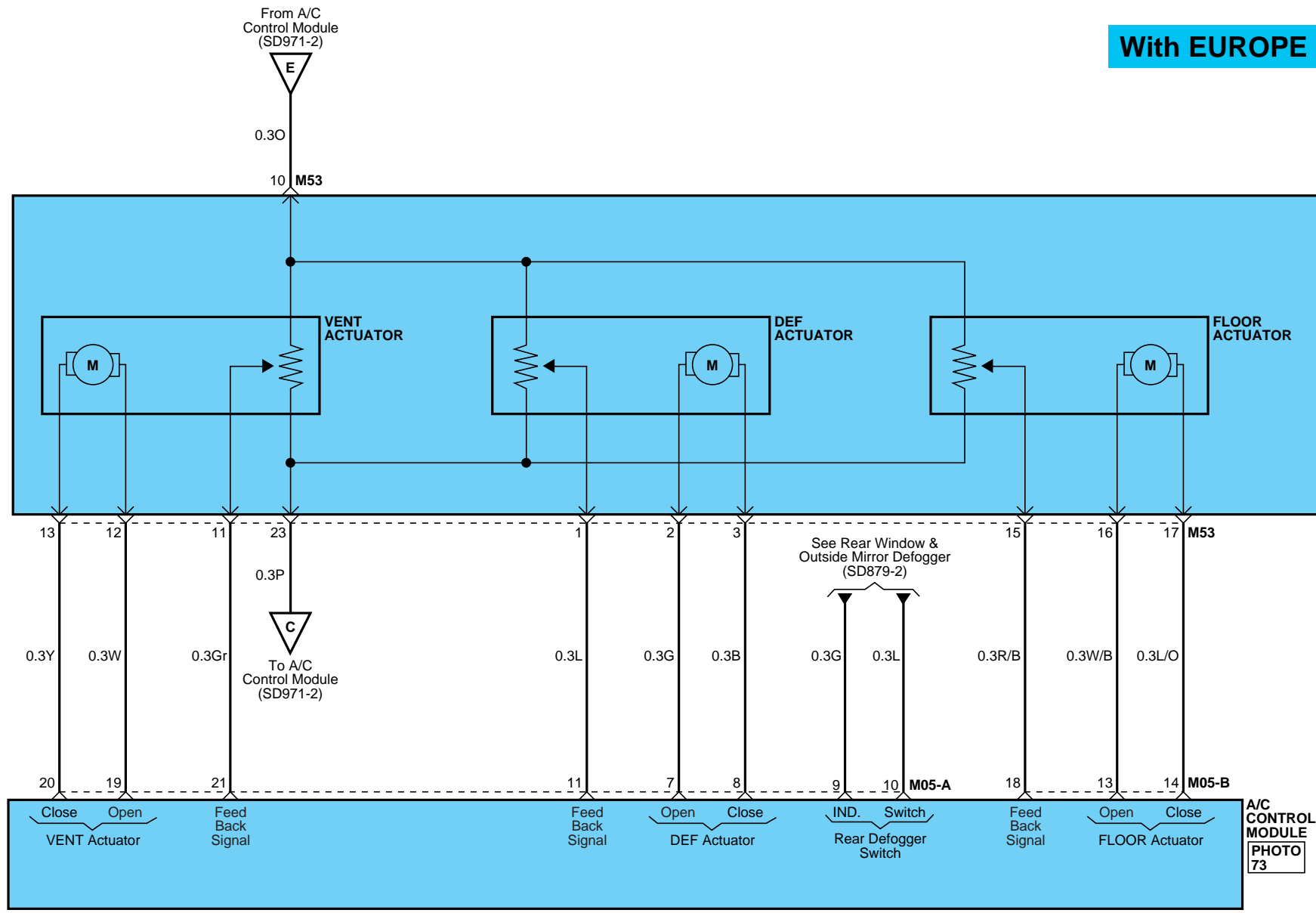

A/C CONTROL MODULE
PHOTO 73

BLOWER & A/C CONTROLS

BLOWER & A/C CONTROLS (AUTO) (4)

SD971-4

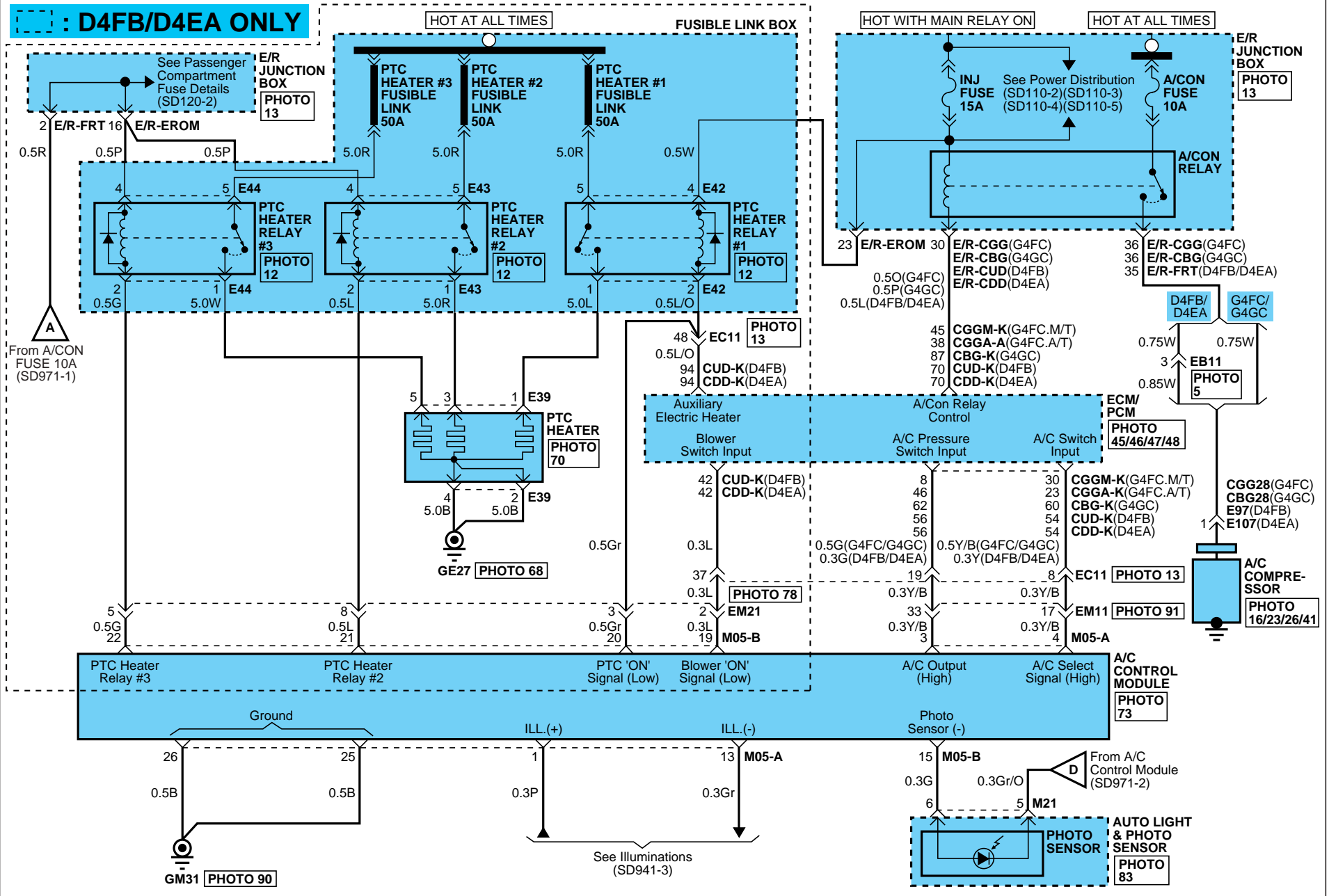

BLOWER & A/C CONTROLS

BLOWER & A/C CONTROLS (AUTO) (5)

SD971-5

CGGA-A

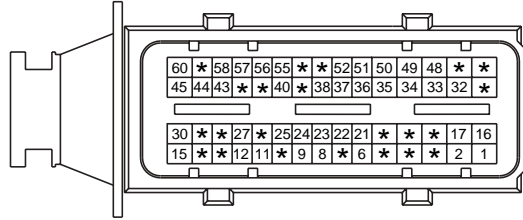

AMP_ECU_60F_B

CGGA-K

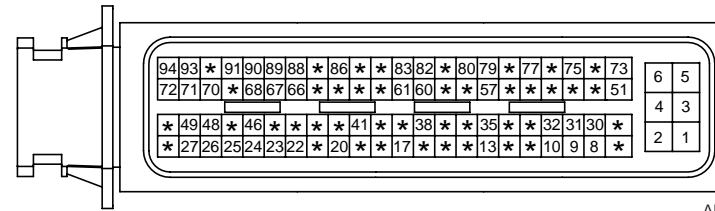

AMP_ECU_94F_B

CGGM-K

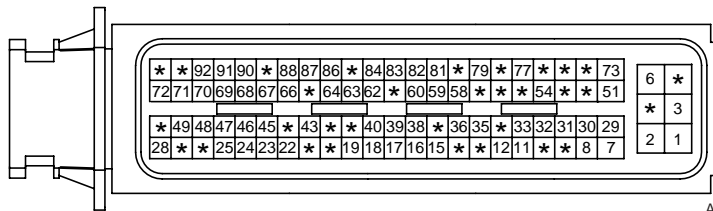

AMP_ECU_94F_B

CBG-K

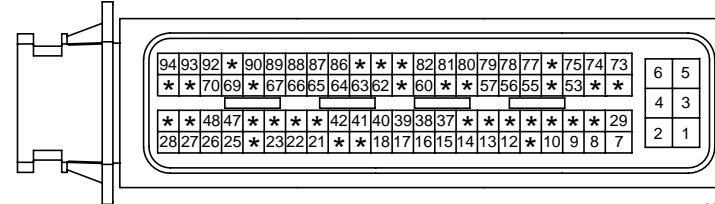

AMP_ECU_94F_B

CUD-K

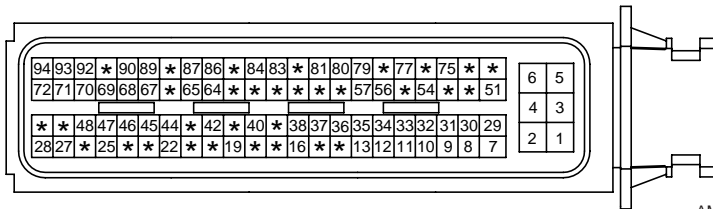

AMP_ECU_94F_B

CDD-K

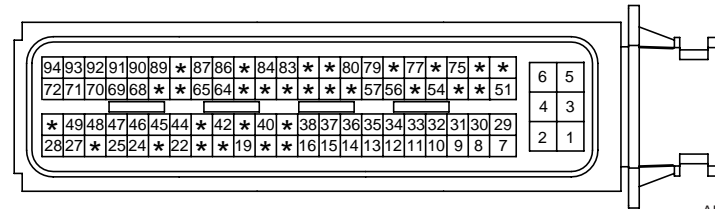

AMP_ECU_94F_B

CGG28



KUM_NMWP_01F_B

CBG28



KUM_NMWP_01F_B

E39

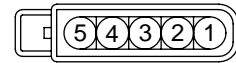

AMP_PTC_05F_B

E42

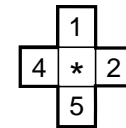

CR05F019

E43

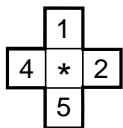

CR05F019

E44

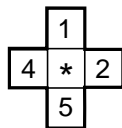

CR05F019

E84-1

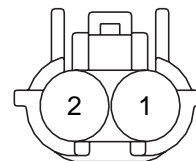

KET_SWP_02F_B

E97





KUM_NMWP_01F_B

BLOWER & A/C CONTROLS

BLOWER & A/C CONTROLS (AUTO) (6)

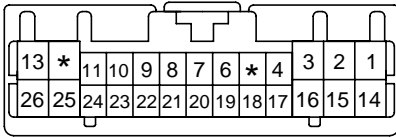
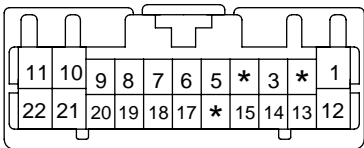
SD971-6

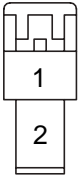
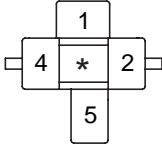
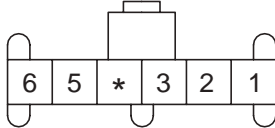
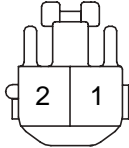
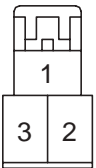
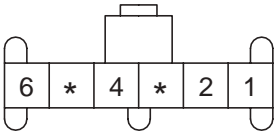
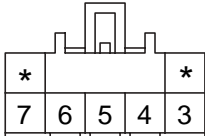
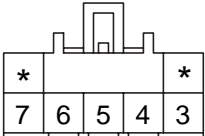
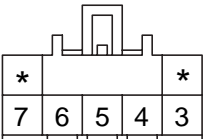
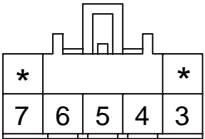
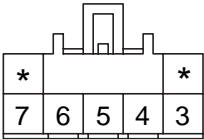
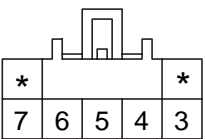
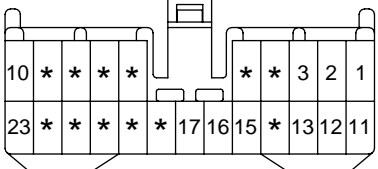
<p>E107</p>  <p>KUM_NMWP_01F_B</p>	<p>M05-A</p>  <p>KET_0407_26F_W</p>	<p>M05-B</p>  <p>KET_0407_22F_W</p>	<p>M15</p>  <p>KET_090II_02F_W_SPK</p>
<p>M16</p>  <p>KUM_DSD_02F_W</p>	<p>M17</p>  <p>KET_250_05F_W_RLY</p>	<p>M21</p>  <p>KET_91A_06F_W</p>	<p>M23</p>  <p>KUM_090II_02F_W_L</p>
<p>M24</p>  <p>KUM_DSD_03F_B</p>	<p>M38</p>  <p>KET_91A_06F_W</p>	<p>M39</p>  <p>KUM_CDR_07F_L</p>	<p>M40</p>  <p>KUM_CDR_07F_L</p>
<p>M43</p>  <p>KUM_CDR_07F_W</p>	<p>M48</p>  <p>KUM_CDR_07F_W</p>	<p>M51</p>  <p>KUM_CDR_07F_L</p>	<p>M52</p>  <p>KUM_CDR_07F_L</p>
<p>M53</p>  <p>KET_050_23F_W</p>	<p>BLANK</p>	<p>BLANK</p>	<p>BLANK</p>

BLOWER & A/C CONTROLS (MANUAL) (1)

SD971-7

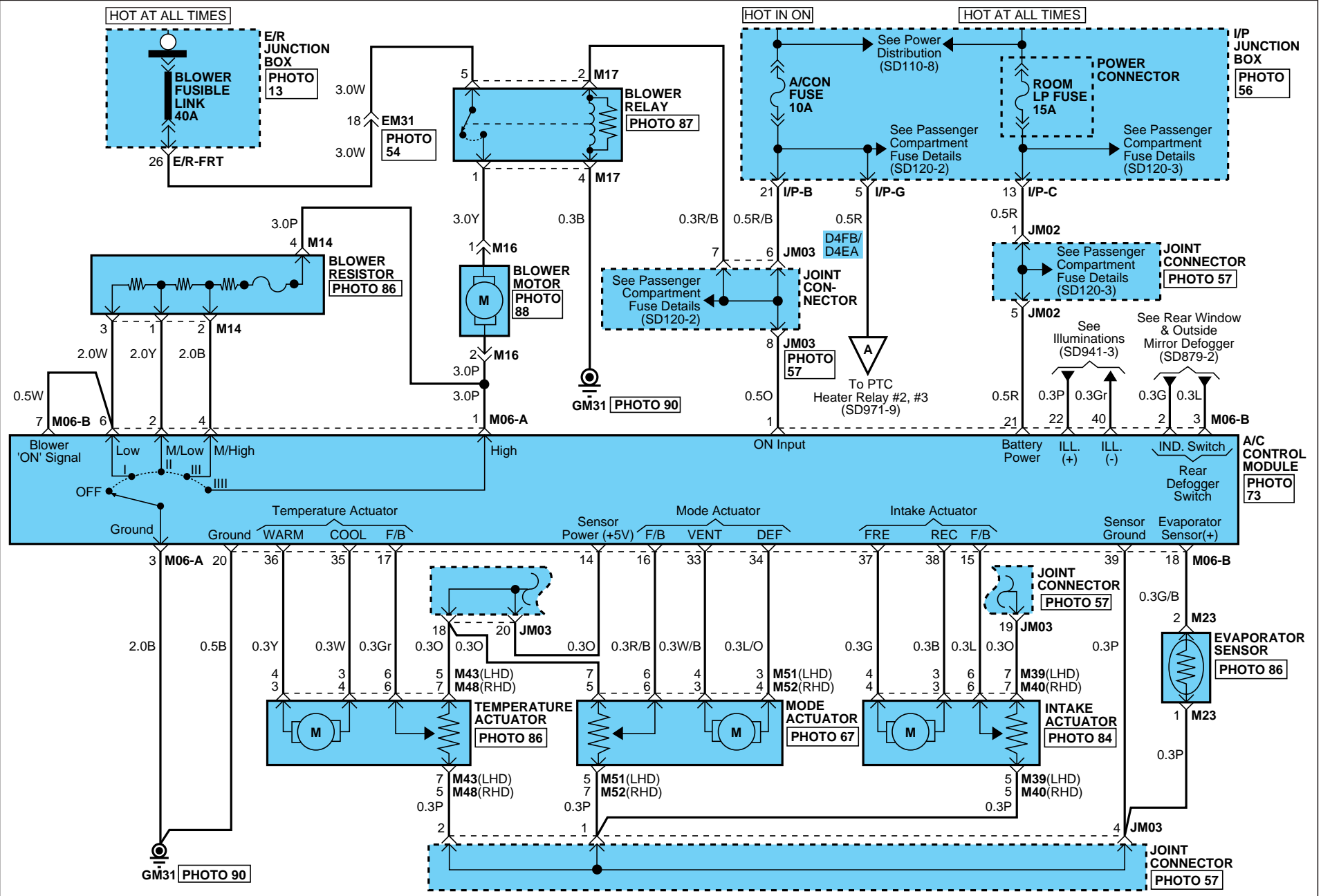

BLOWER & A/C CONTROLS

BLOWER & A/C CONTROLS (MANUAL) (2)

SD971-8

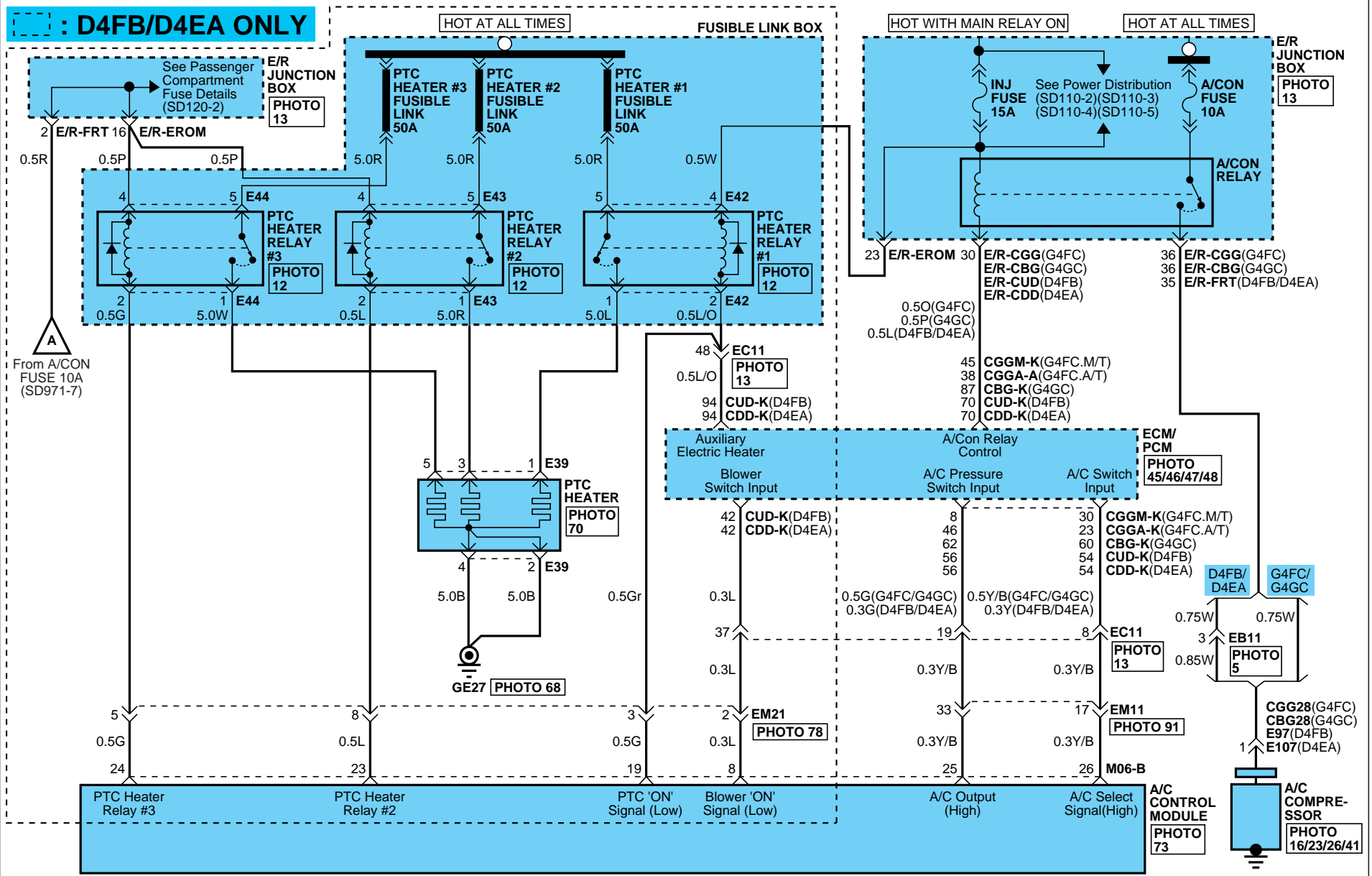

BLOWER & A/C CONTROLS

BLOWER & A/C CONTROLS (MANUAL) (3)

SD971-9

With EUROPE

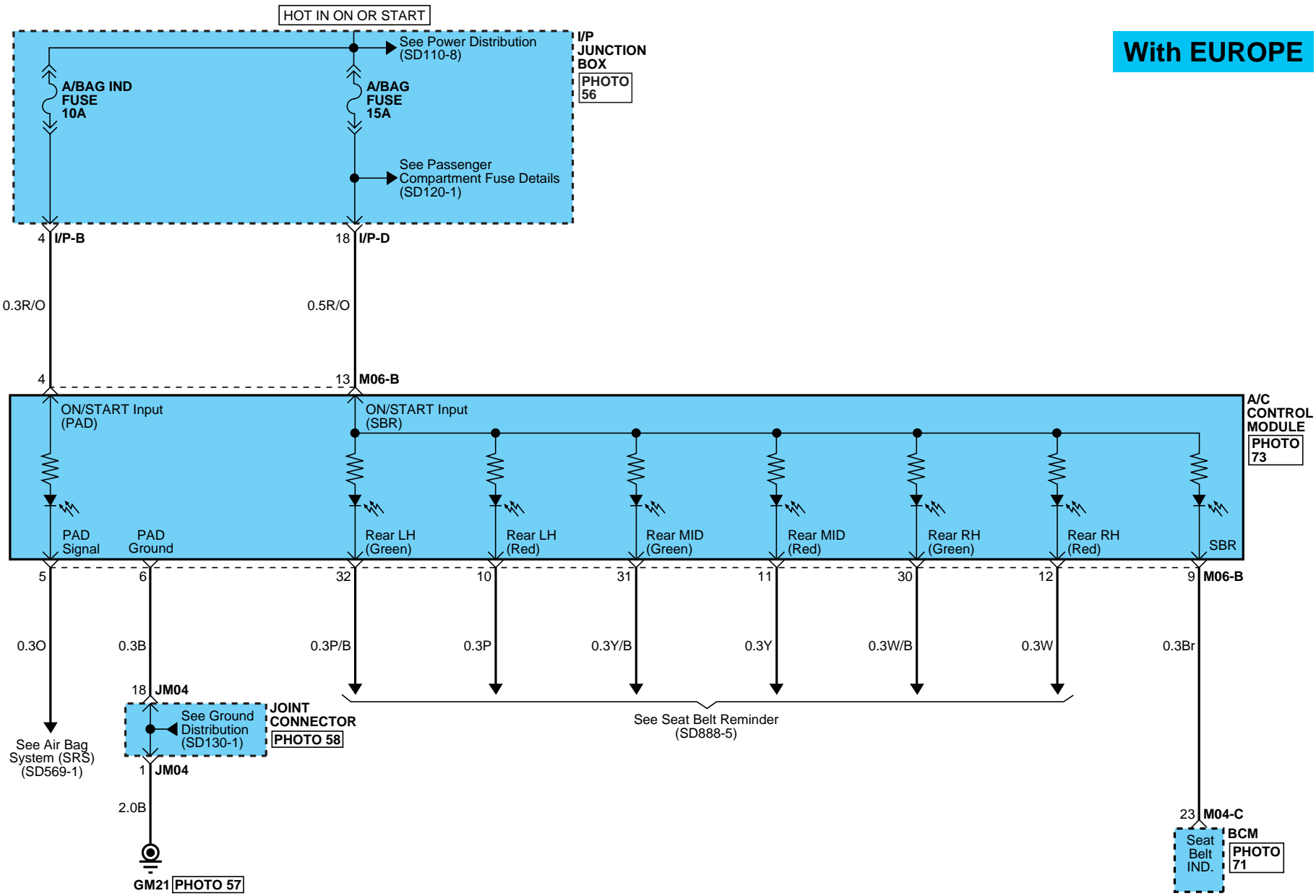

BLOWER & A/C CONTROLS

BLOWER & A/C CONTROLS (MANUAL) (4)

SD971-10

CGGA-A

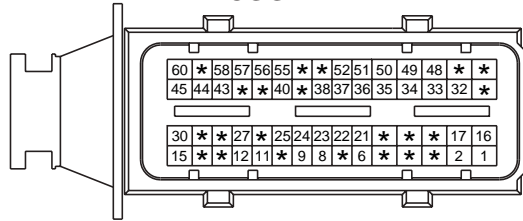

AMP_ECU_60F_B

CGGA-K

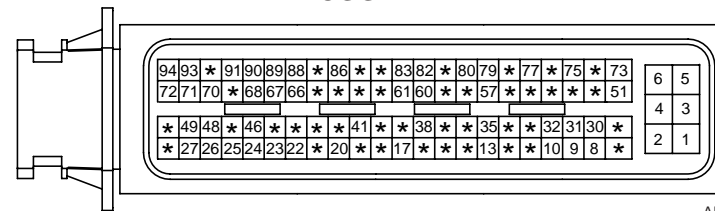

AMP_ECU_94F_B

CGGM-K

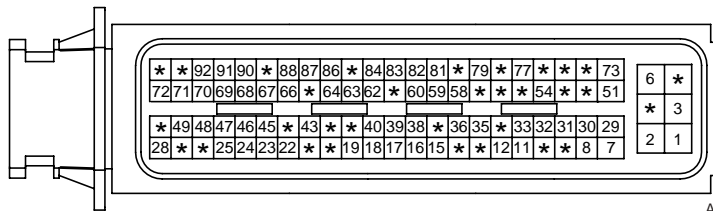

AMP_ECU_94F_B

CBG-K

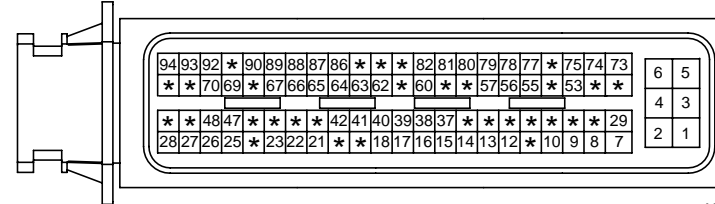

AMP_ECU_94F_B

CUD-K

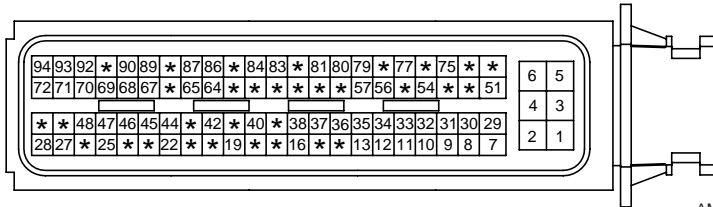

AMP_ECU_94F_B

CDD-K

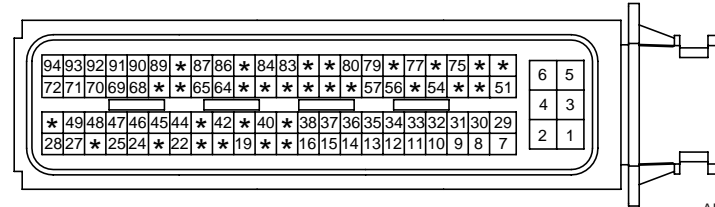

AMP_ECU_94F_B

CGG28



KUM_NMWP_01F_B

CBG28



KUM_NMWP_01F_B

E39

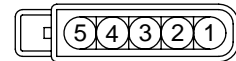

AMP_PTC_05F_B

E42

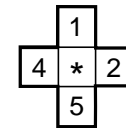

CR05F019

E43

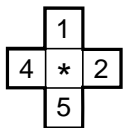

CR05F019

E44

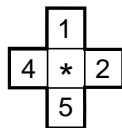

CR05F019

E97



KUM_NMWP_01F_B

E107



KUM_NMWP_01F_B

BLOWER & A/C CONTROLS

BLOWER & A/C CONTROLS (MANUAL) (5)

SD971-11

M04-C

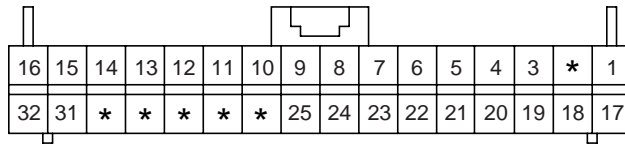

AMP_025_32F_W

M06-A

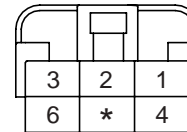

KET_250DL_06F_W

BLANK

M06-B

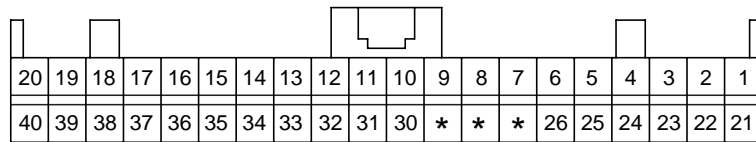

AMP_025_40F_W

M14

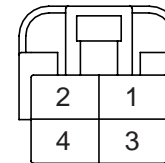

KET_250DL_04F_W

M16

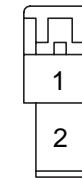

KUM_DSD_02F_W

M17

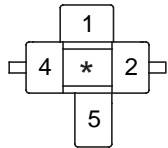

KET_250_05F_W_RLY

M23

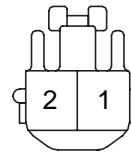

KET_090II_02F_W_L

M39

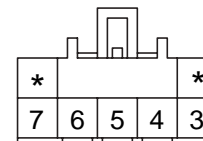

KUM_CDR_07F_L

M40

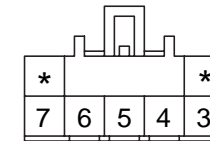

KUM_CDR_07F_L

M43

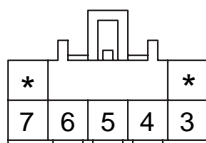

KUM_CDR_07F_W

M48

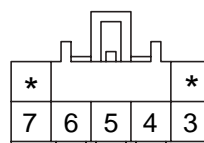

KUM_CDR_07F_W

M51

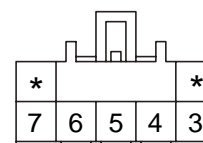

KUM_CDR_07F_L

M52

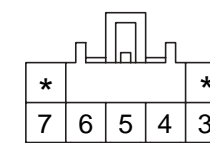

KUM_CDR_07F_L

BLOWER & A/C CONTROLS

BLOWER & A/C CONTROLS (MANUAL) (6)

SD971-12

MEMO

FRONT WIPER & WASHER (1)

SD981-1

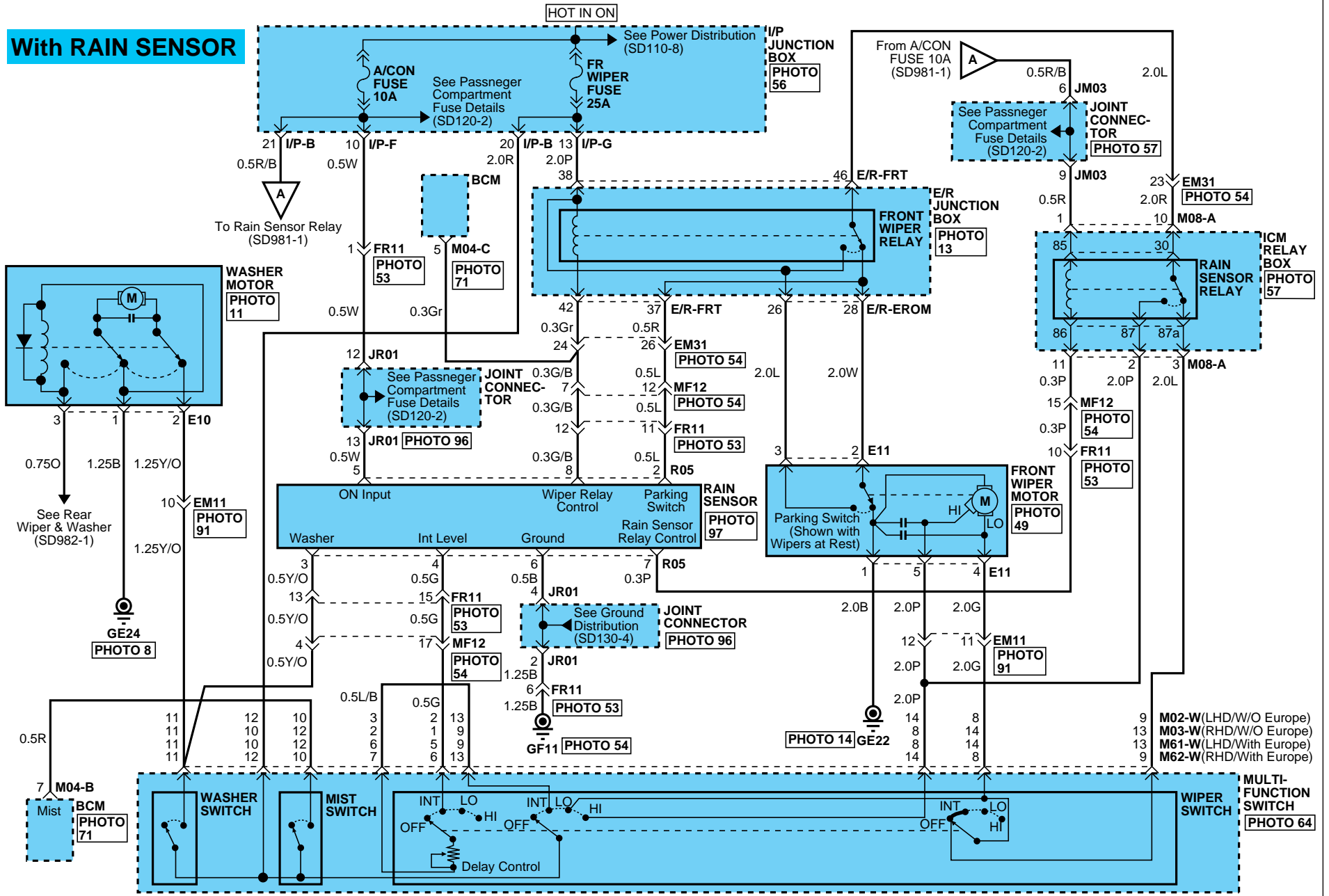

FRONT WIPER & WASHER

FRONT WIPER & WASHER (2)

SD981-2

W/O RAIN SENSOR

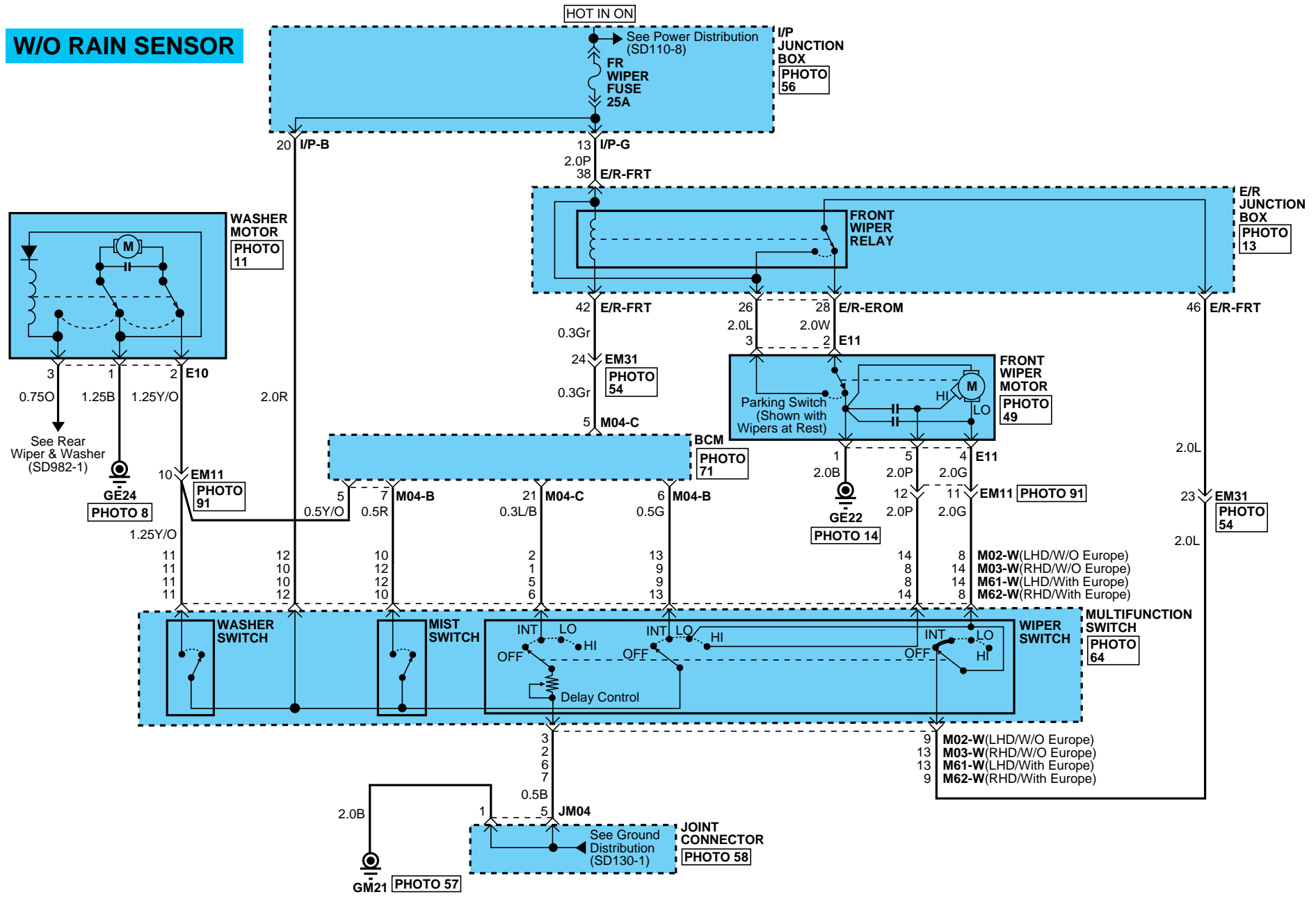

FRONT WIPER & WASHER

FRONT WIPER & WASHER (3)

SD981-3

E10



KET_090IWP_03F_Gr

E11

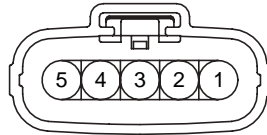

KUM_NDWP_05F_B

M02-W

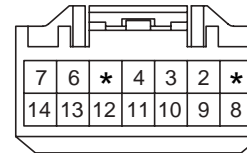

AMP_090III_14F_W

M03-W

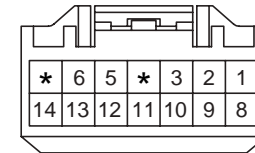

AMP_090III_14F_W

M04-B

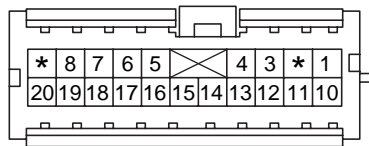

AMP_040III_20F_W

M04-C

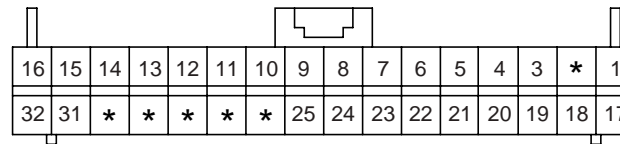

AMP_025_32F_W

M08-A

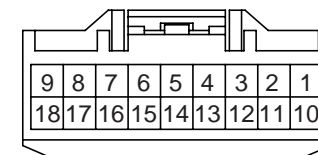

AMP_090III_18F_W

M61-W

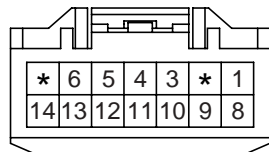

AMP_090III_14F_W

M62-W

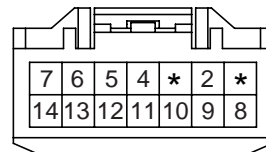

AMP_090III_14F_W

R05

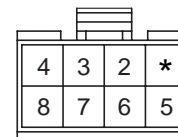

MLX_118_08F_B

BLANK

FRONT WIPER & WASHER

FRONT WIPER & WASHER (4)

SD981-4

MEMO

REAR WIPER & WASHER (1)

SD982-1

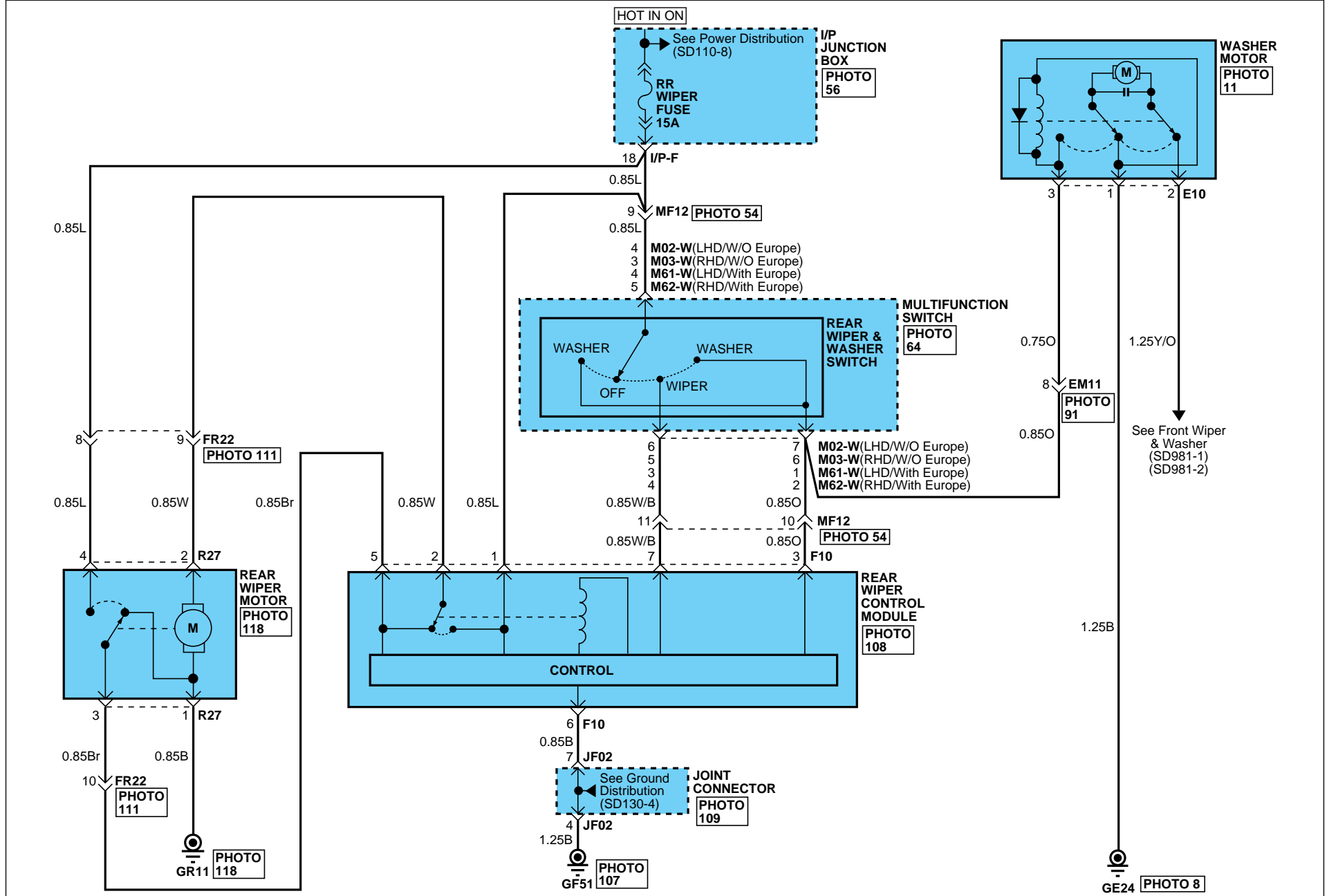

REAR WIPER & WASHER

REAR WIPER & WASHER (2)

SD982-2

E10



KET_090IWP_03F_Gr

F10

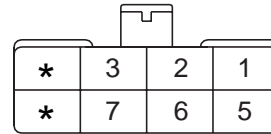

KET_250_08F_W

M02-W

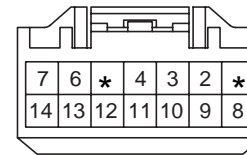

AMP_090III_14F_W

M03-W

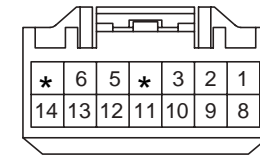

AMP_090III_14F_W

M61-W

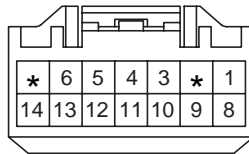

AMP_090III_14F_W

M62-W

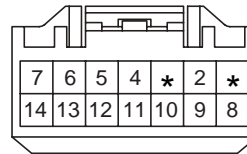

AMP_090III_14F_W

R27

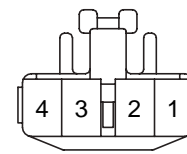

KET_090II_04F_W

BLANK

COMPONENT LOCATIONS(1)

CL-1

PHOTO.1

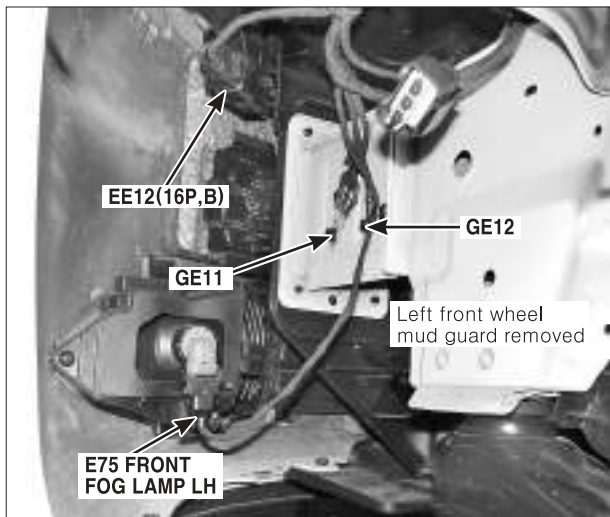

PHOTO.2

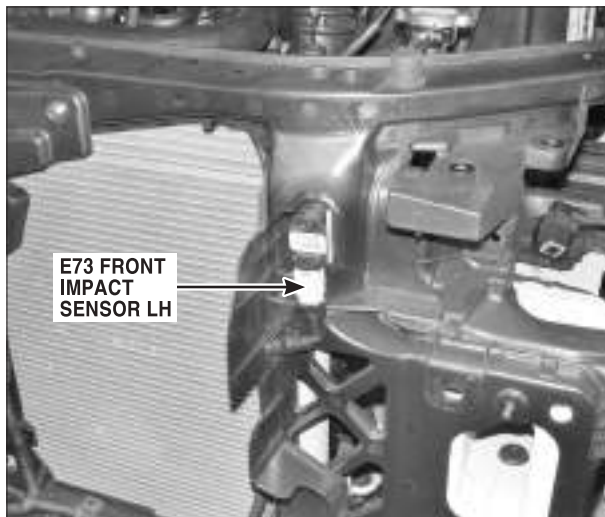

PHOTO.3

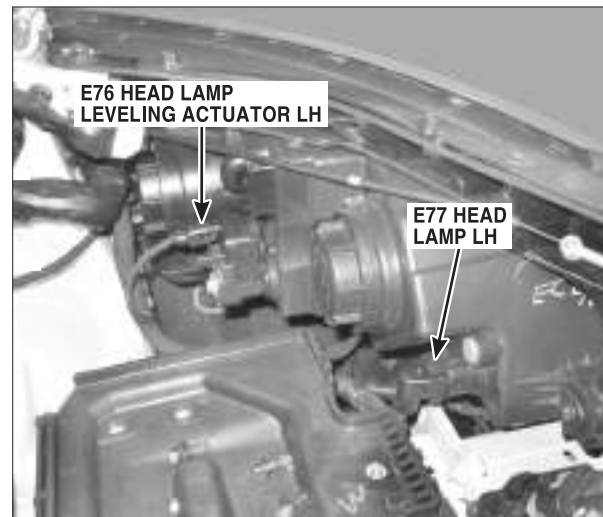

PHOTO.4

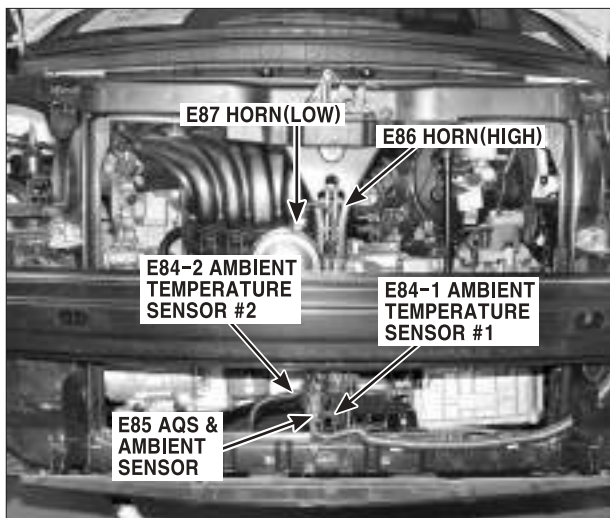

PHOTO.5

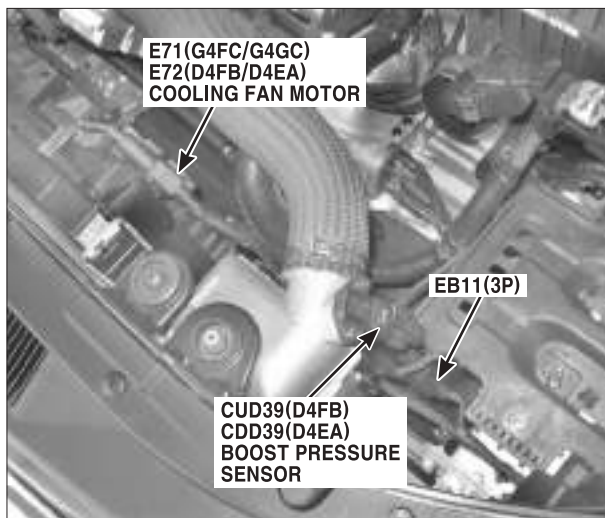
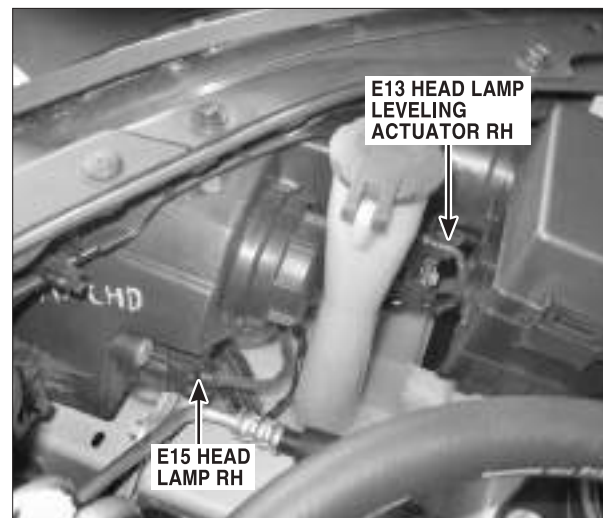

PHOTO.6



COMPONENT LOCATIONS

COMPONENT LOCATIONS(2)

CL-2

PHOTO.7

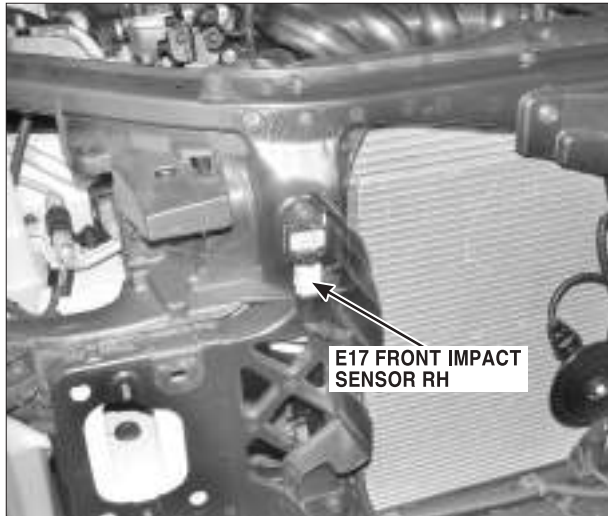

PHOTO.8

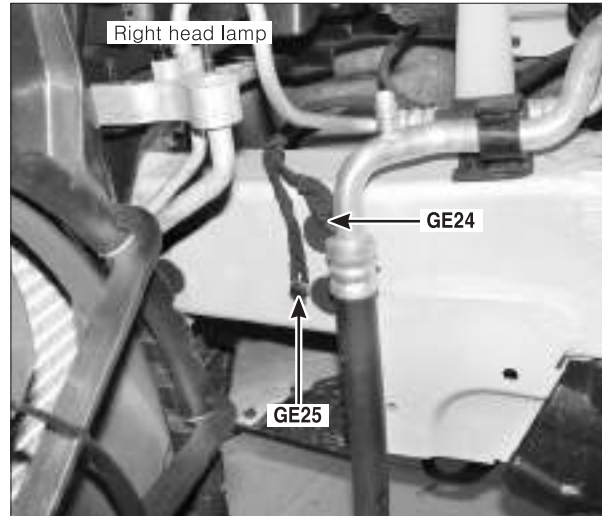

PHOTO.9

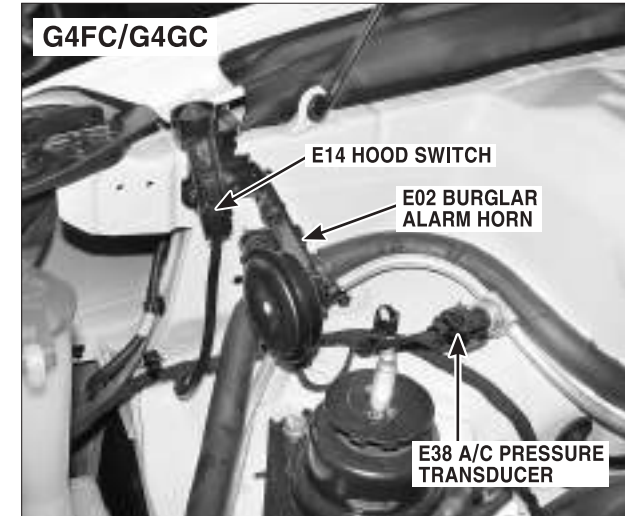

PHOTO.10



PHOTO.11

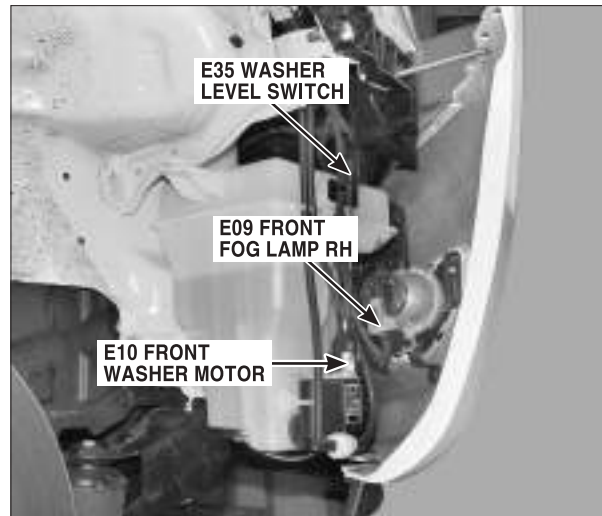
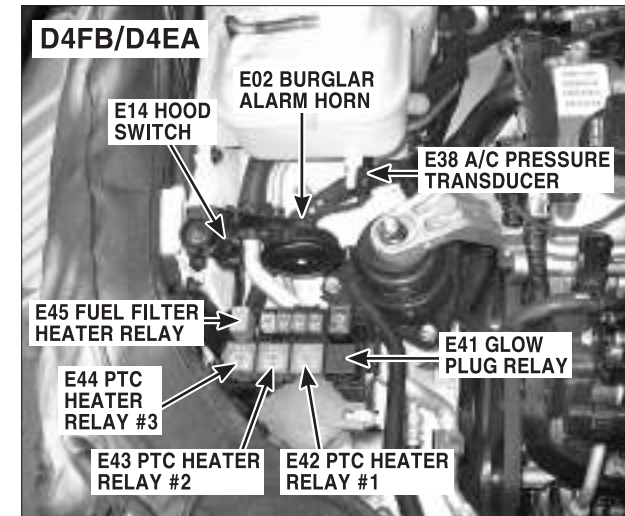

PHOTO.12



COMPONENT LOCATIONS

COMPONENT LOCATIONS(3)

CL-3

PHOTO.13

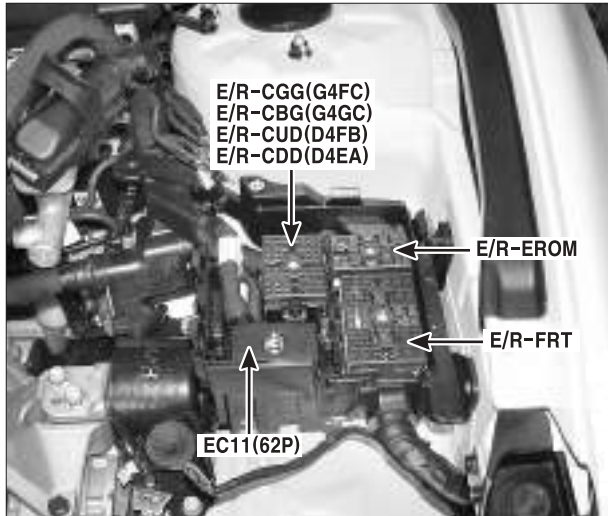

PHOTO.14

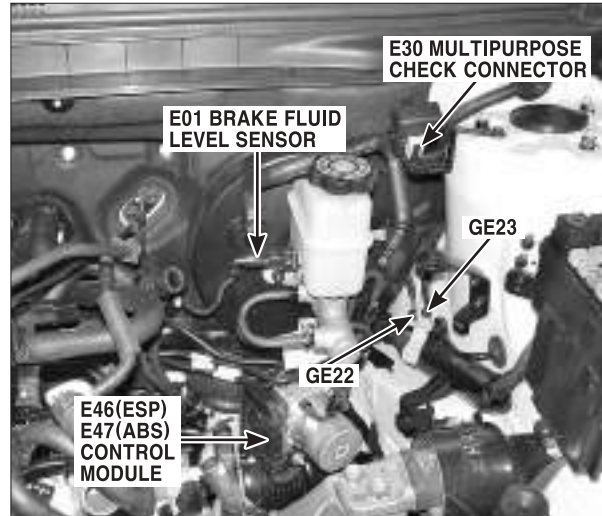

PHOTO.15

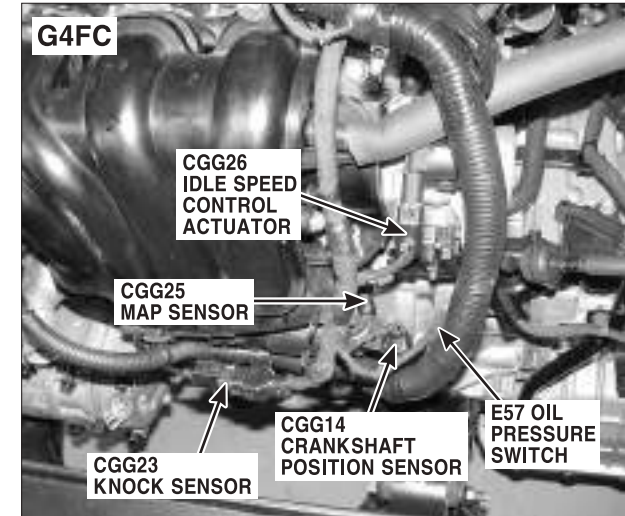

PHOTO.16

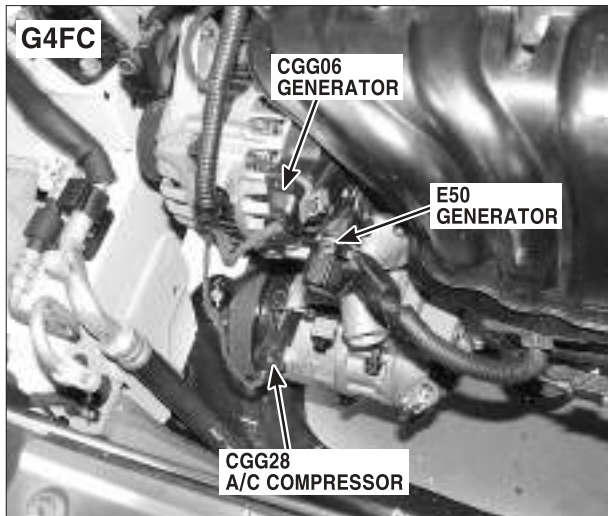

PHOTO.17

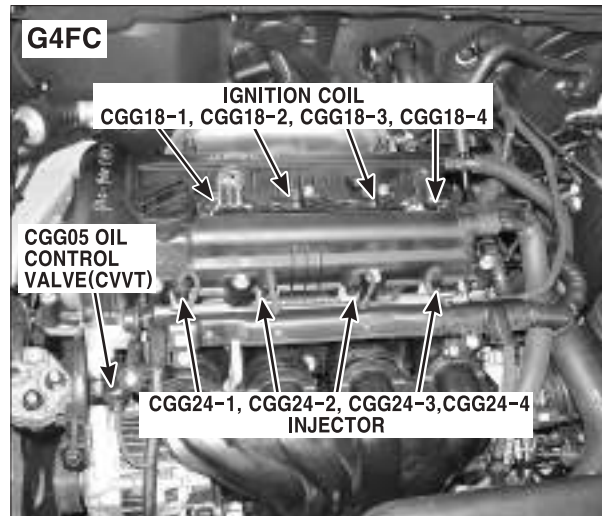
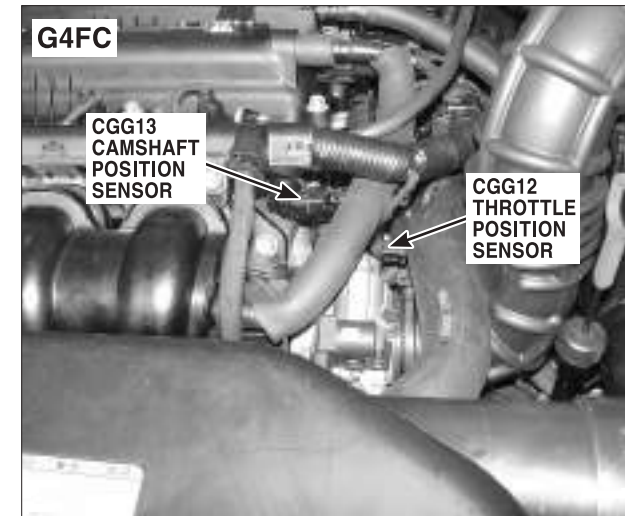

PHOTO.18



COMPONENT LOCATIONS

COMPONENT LOCATIONS(4)

CL-4

PHOTO.19

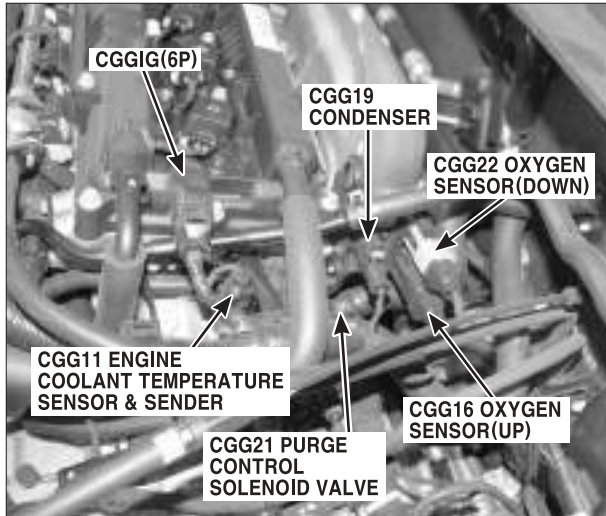

PHOTO.20

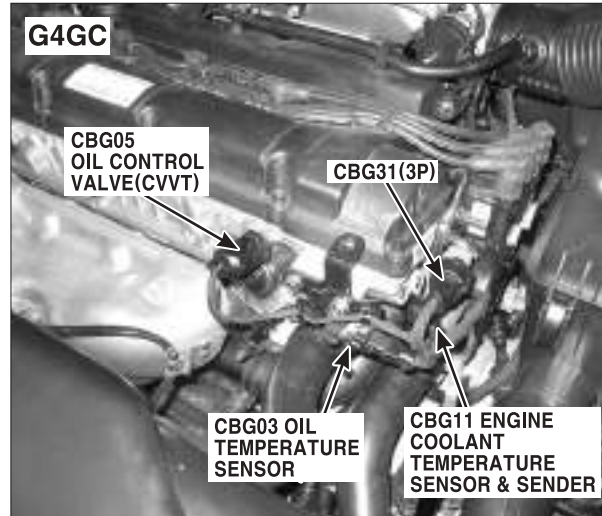

PHOTO.21

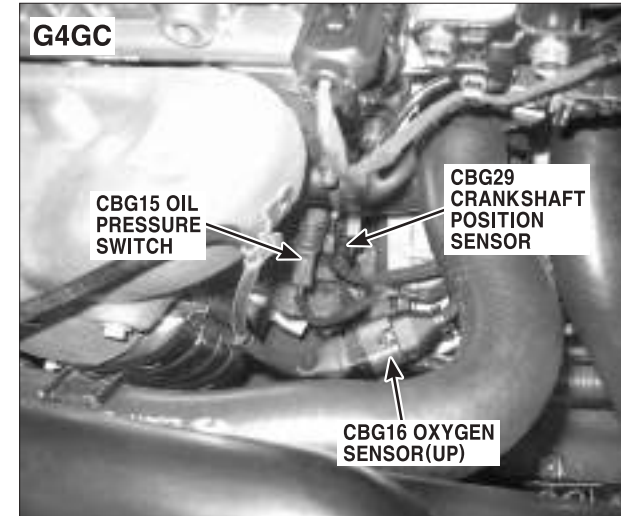

PHOTO.22

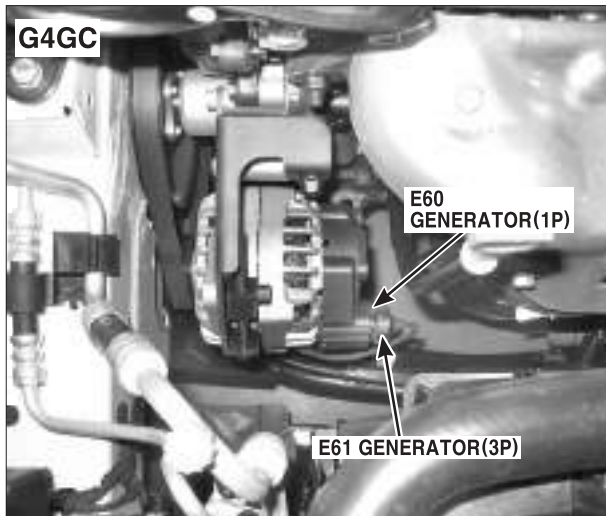

PHOTO.23

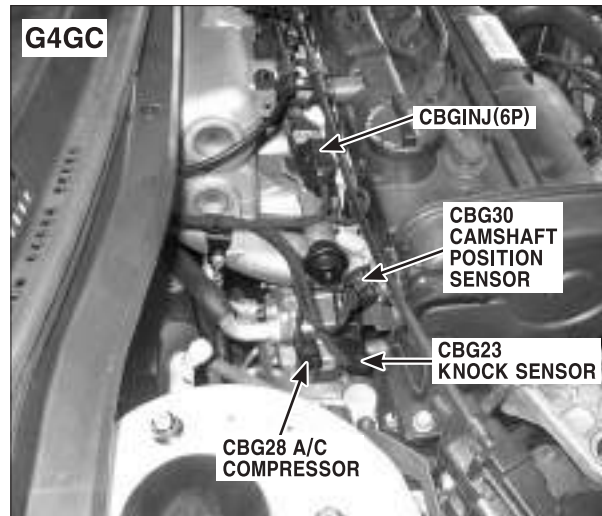
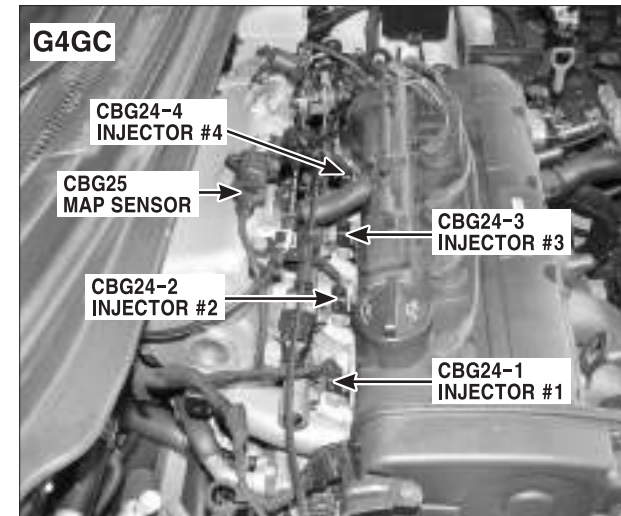

PHOTO.24



COMPONENT LOCATIONS

COMPONENT LOCATIONS(5)

CL-5

PHOTO.25

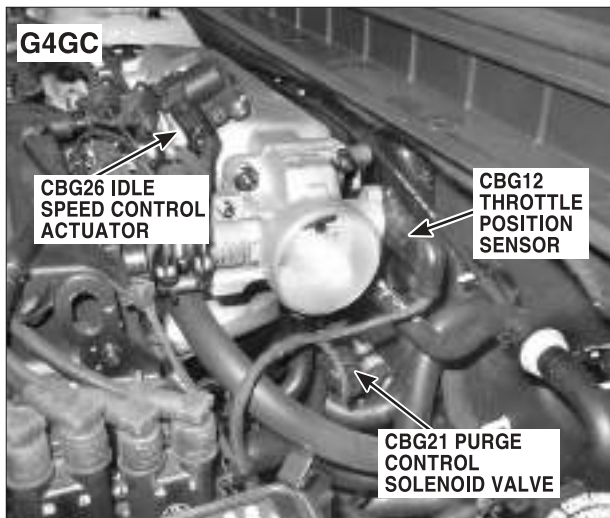

PHOTO.26

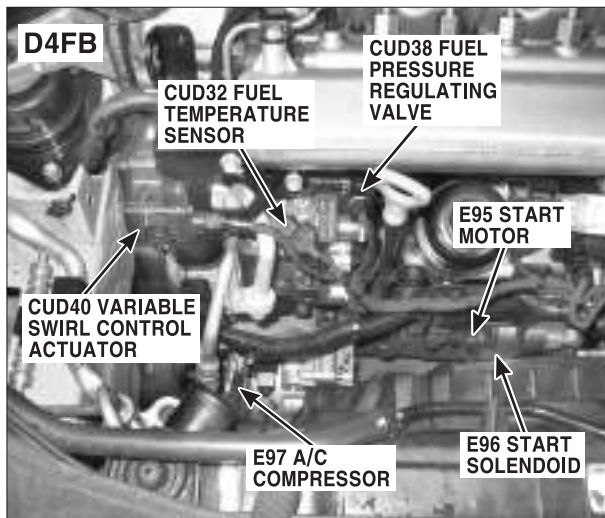

PHOTO.27

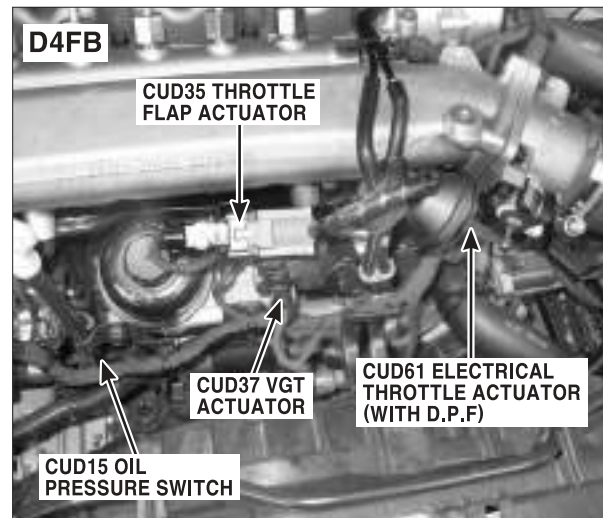

PHOTO.28

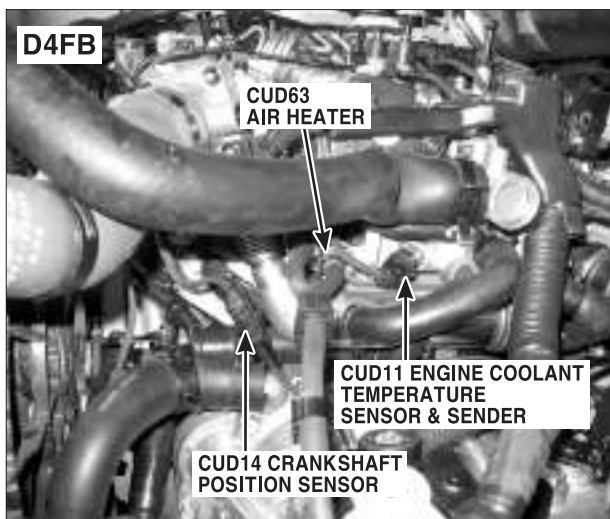

PHOTO.29

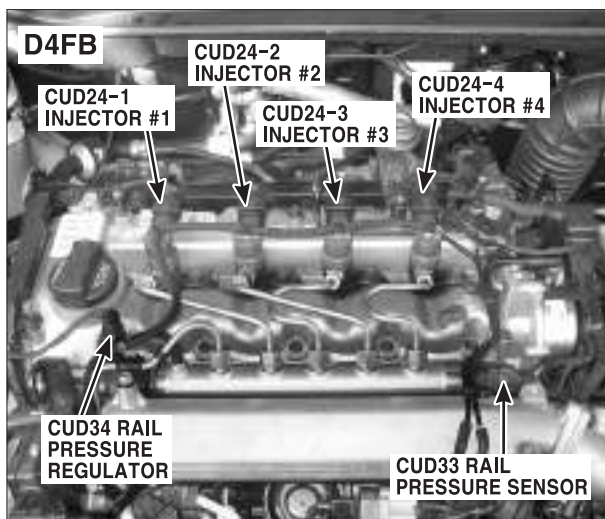
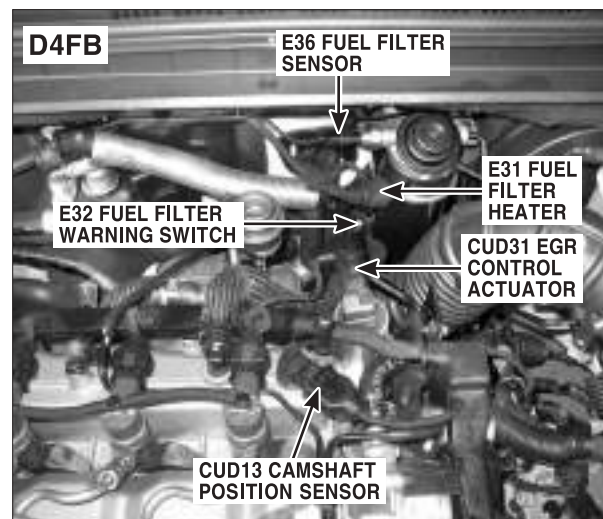

PHOTO.30



COMPONENT LOCATIONS

COMPONENT LOCATIONS(6)

CL-6

PHOTO.31

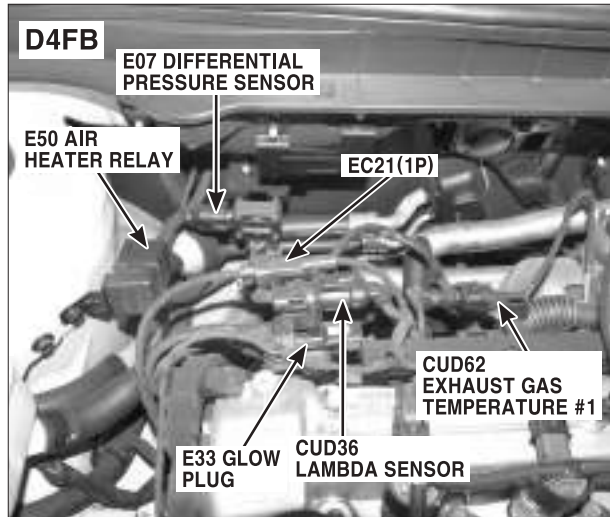

PHOTO.32

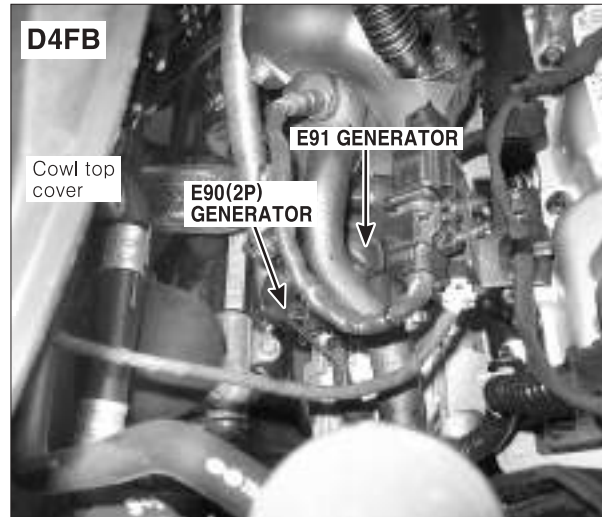

PHOTO.33

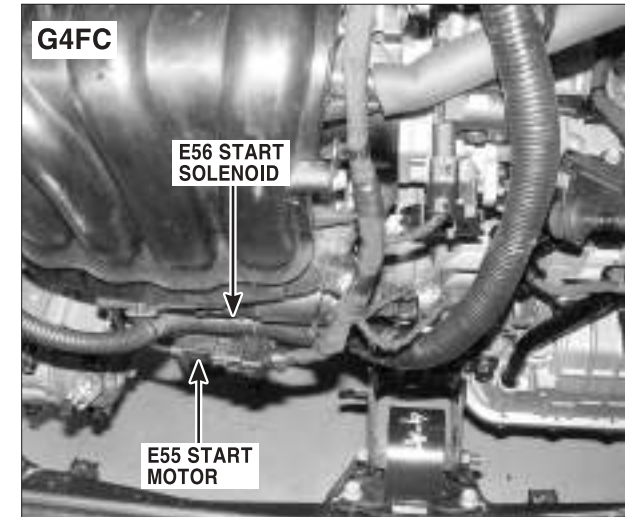

PHOTO.34

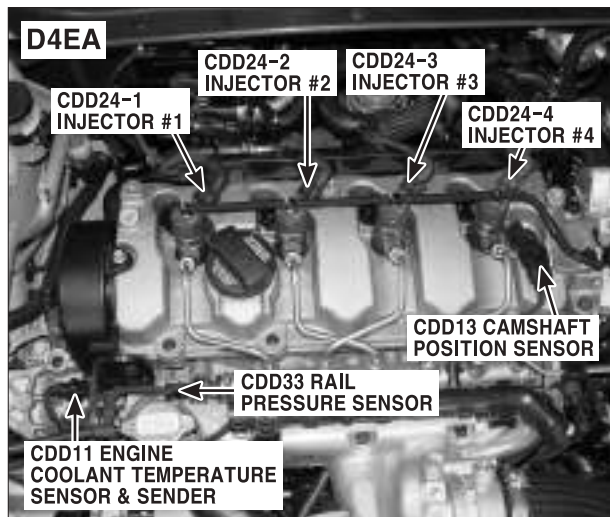

PHOTO.35

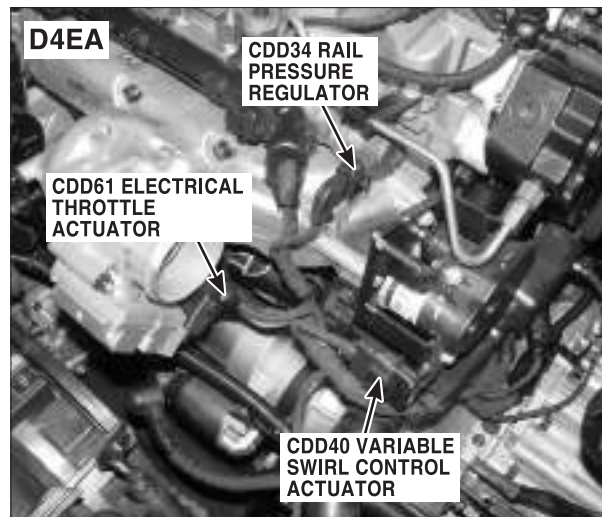
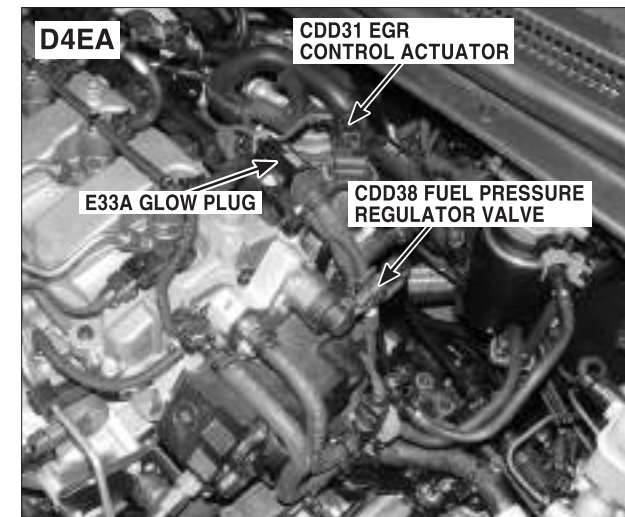

PHOTO.36



COMPONENT LOCATIONS

COMPONENT LOCATIONS(7)

CL-7

PHOTO.37

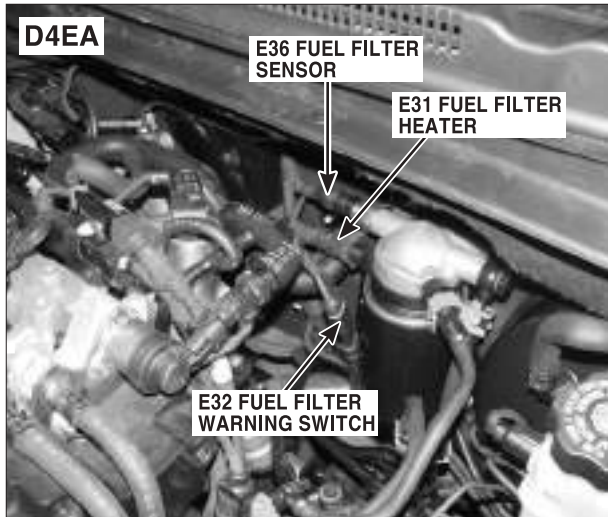

PHOTO.38

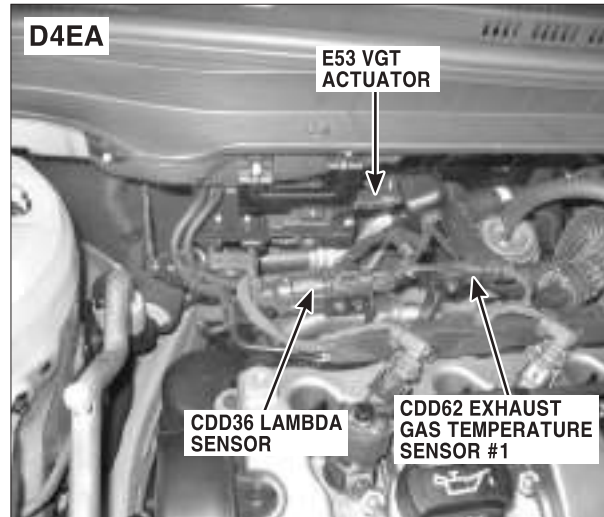

PHOTO.39

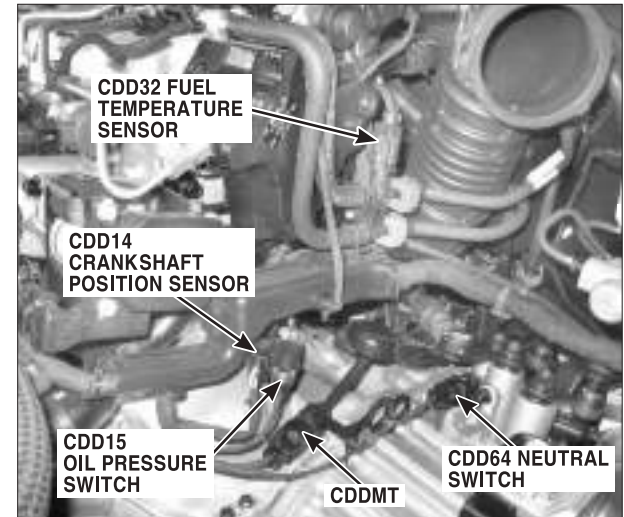

PHOTO.40

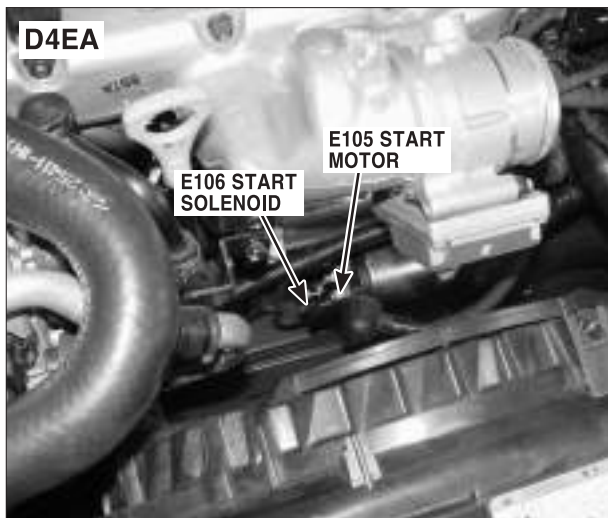

PHOTO.41

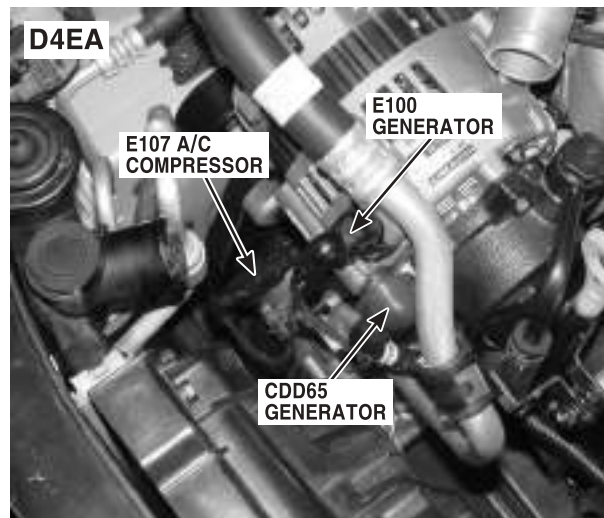
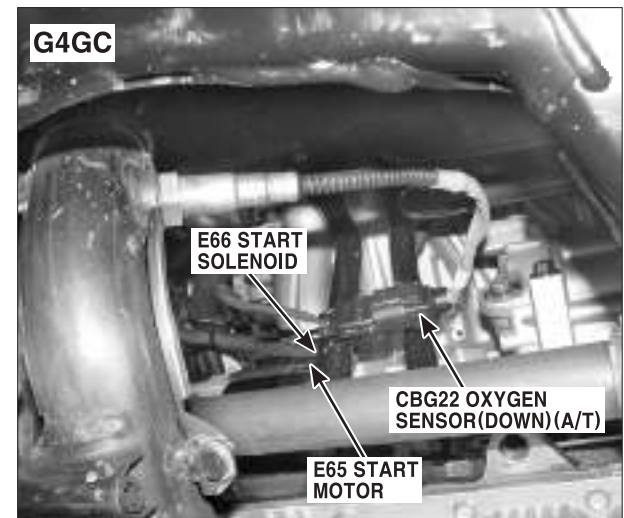

PHOTO.42



COMPONENT LOCATIONS

COMPONENT LOCATIONS(8)

CL-8

PHOTO.43

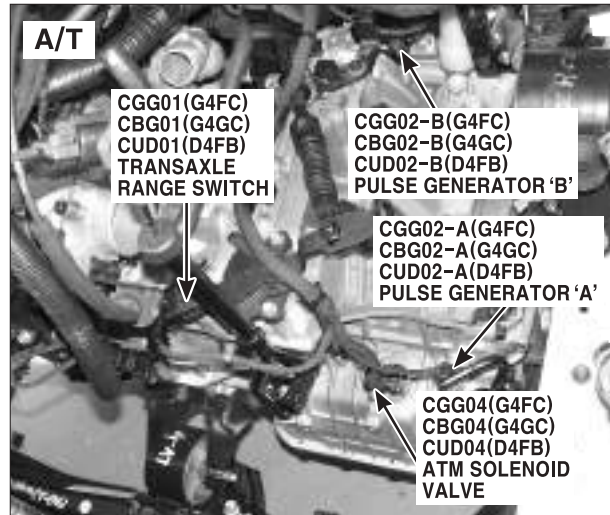

PHOTO.44

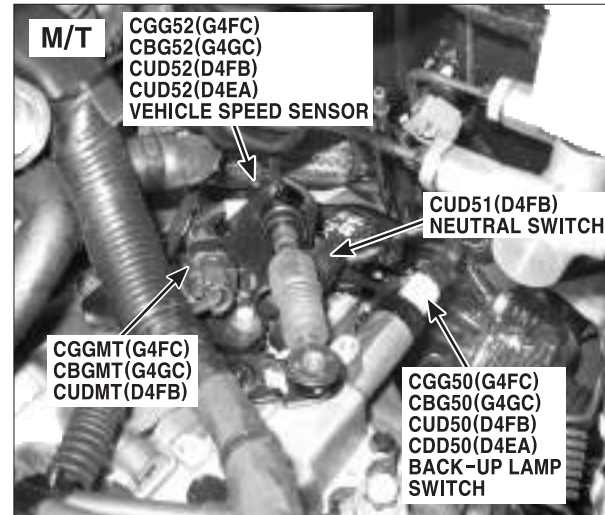

PHOTO.45

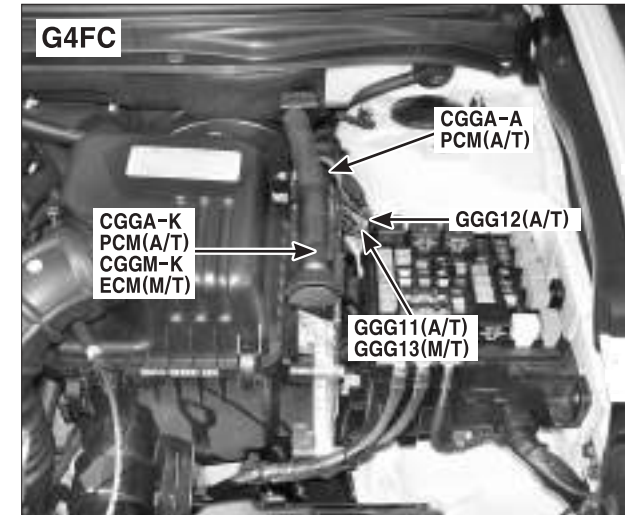

PHOTO.46

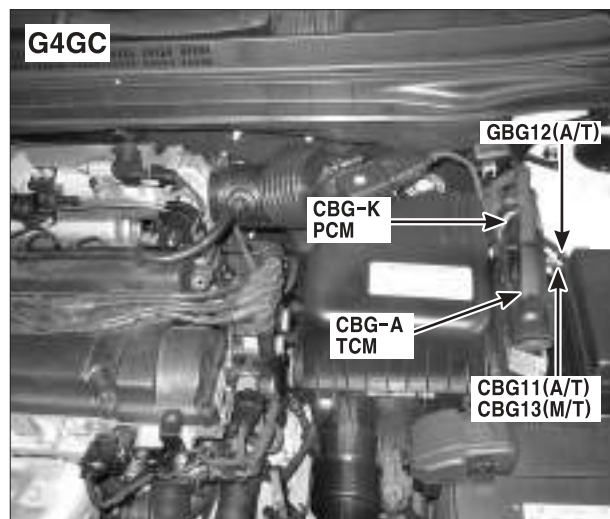

PHOTO.47

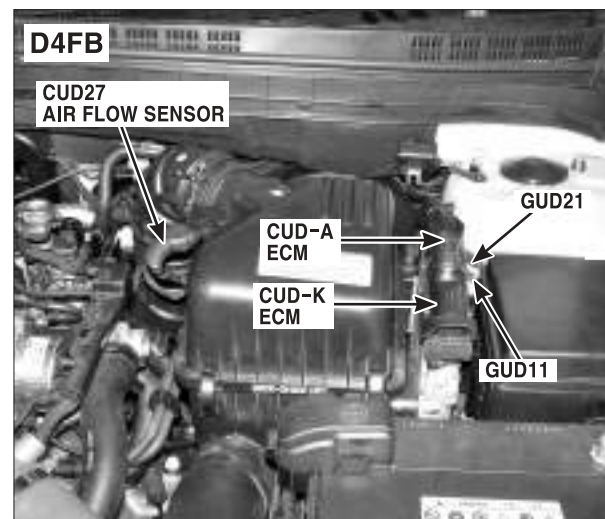
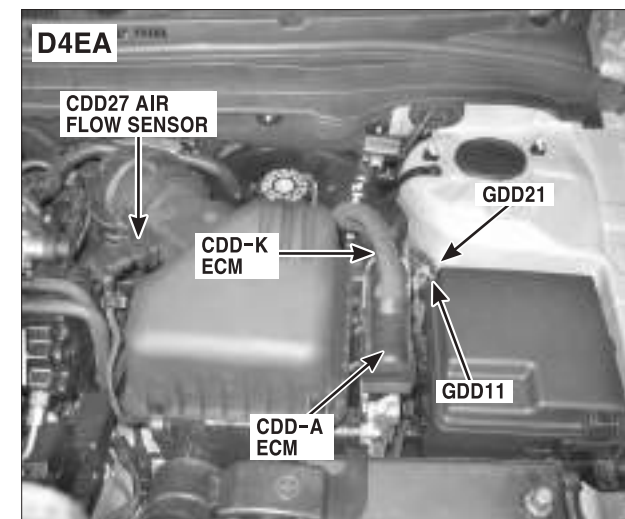

PHOTO.48



COMPONENT LOCATIONS

COMPONENT LOCATIONS(9)

CL-9

PHOTO.49

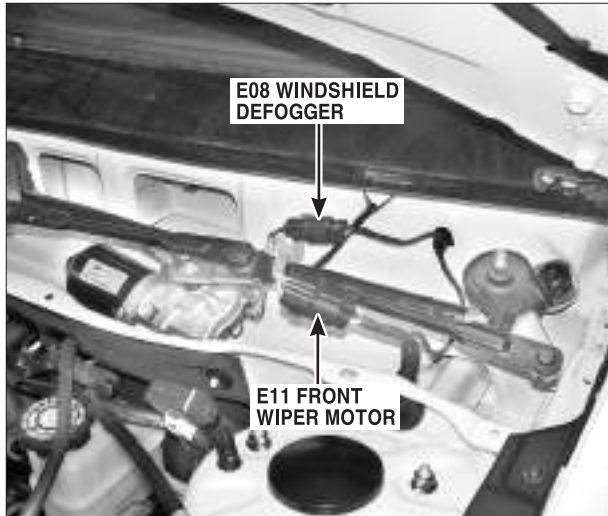

PHOTO.50

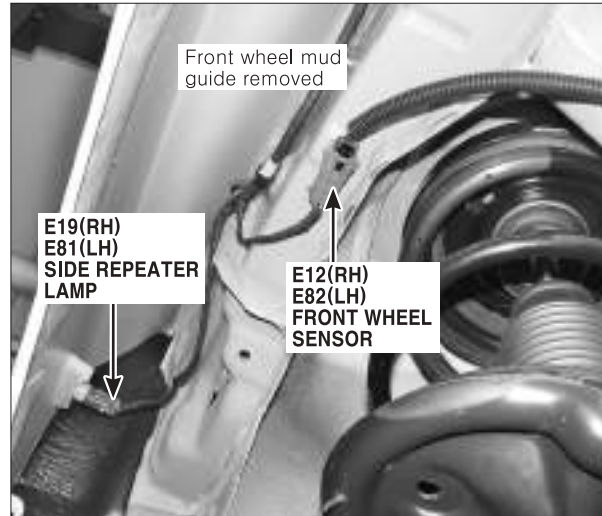

PHOTO.51

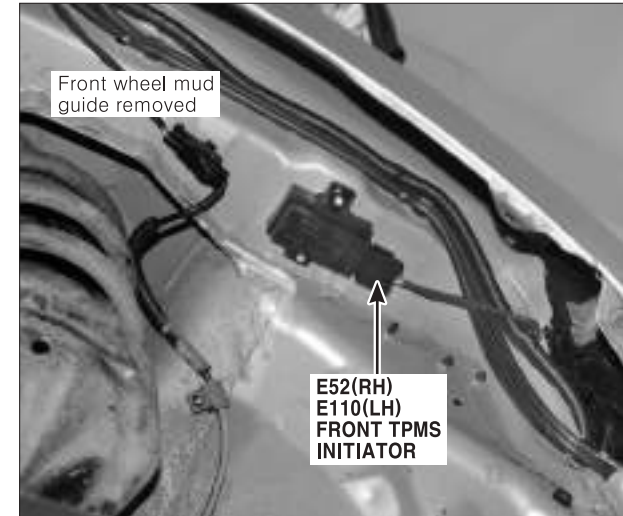

PHOTO.52



PHOTO.53

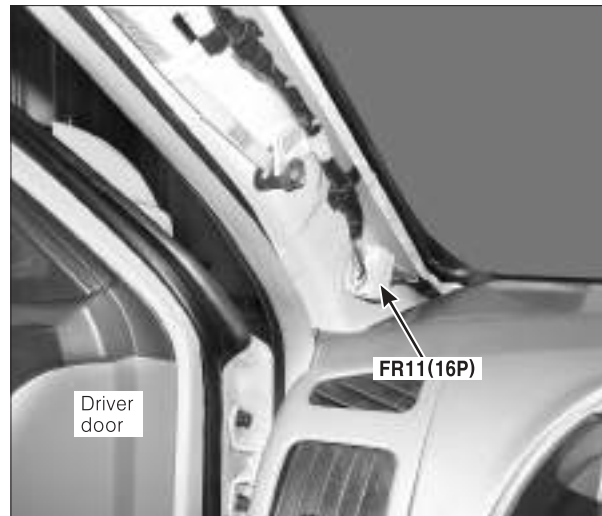
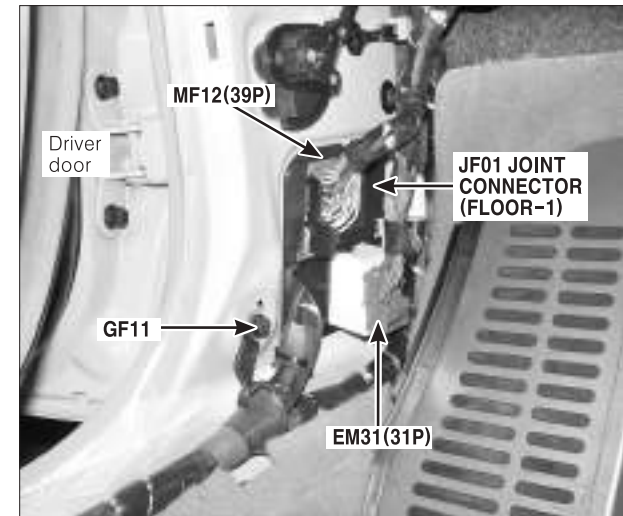

PHOTO.54



COMPONENT LOCATIONS

COMPONENT LOCATIONS(10)

CL-10

PHOTO.55

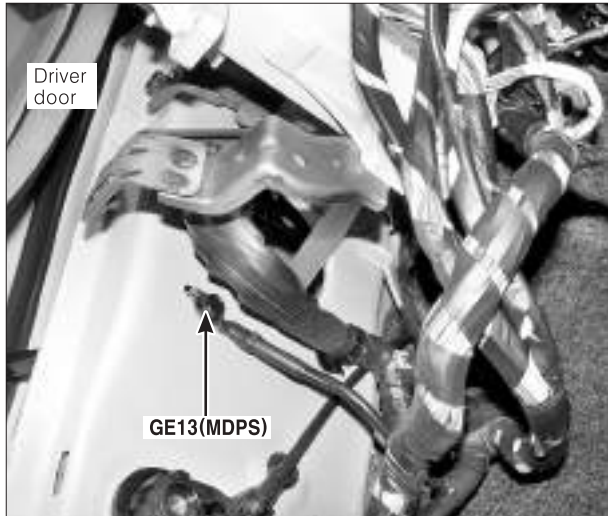

PHOTO.56

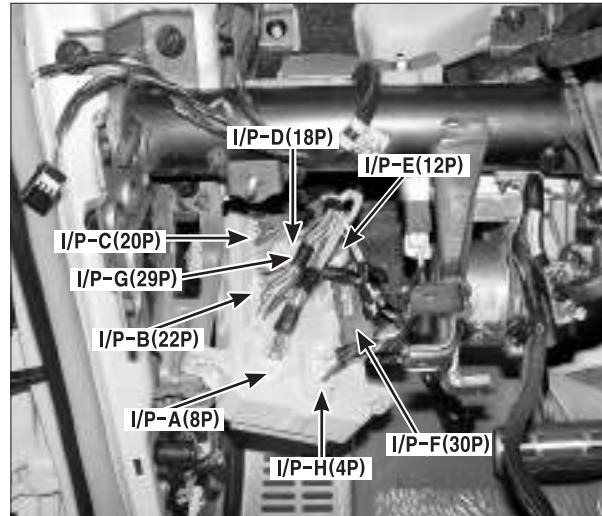

PHOTO.57

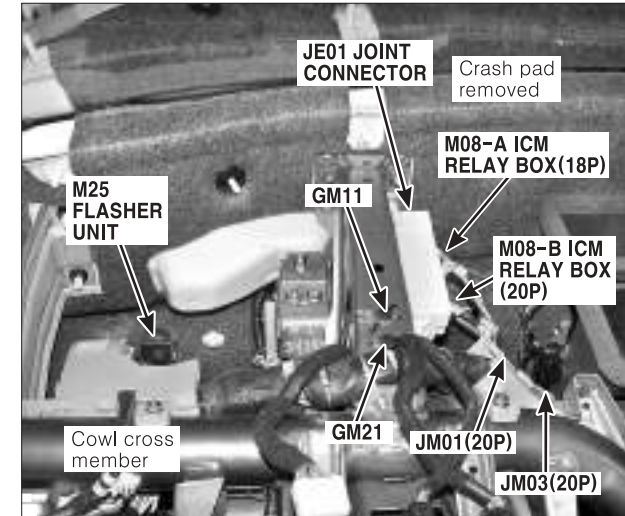

PHOTO.58

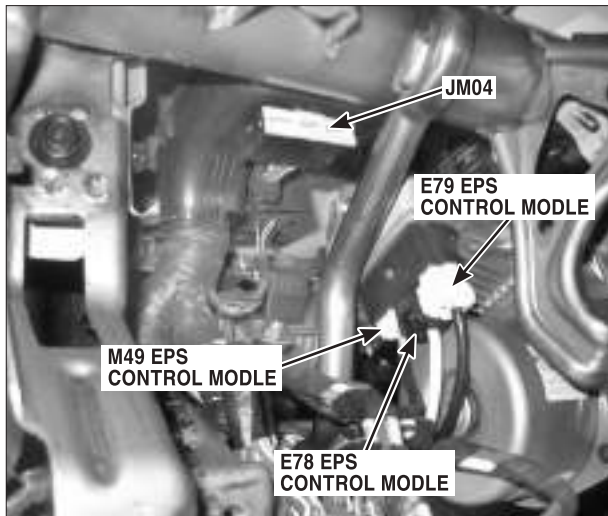

PHOTO.59

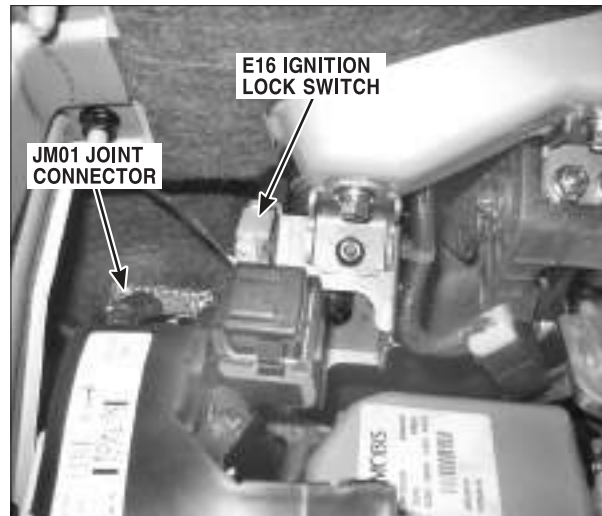
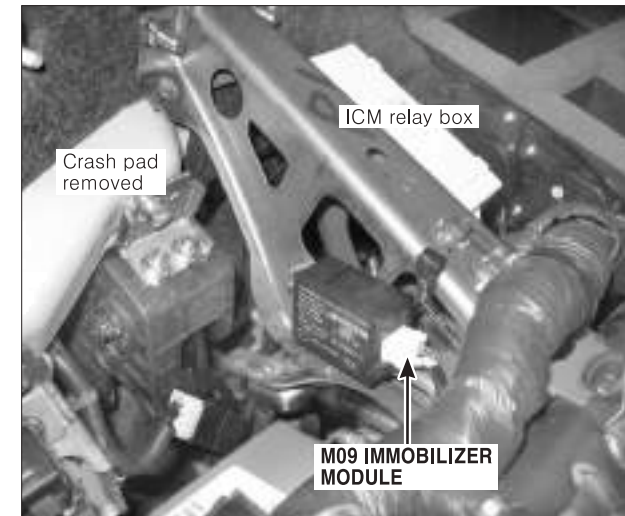

PHOTO.60



COMPONENT LOCATIONS

COMPONENT LOCATIONS(11)

CL-11

PHOTO.61

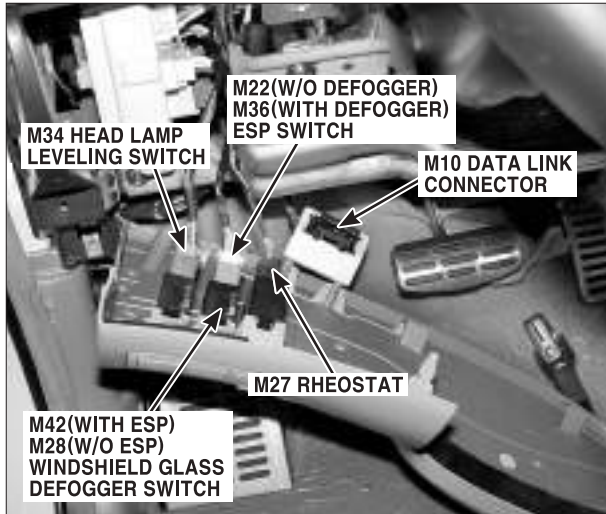

PHOTO.62

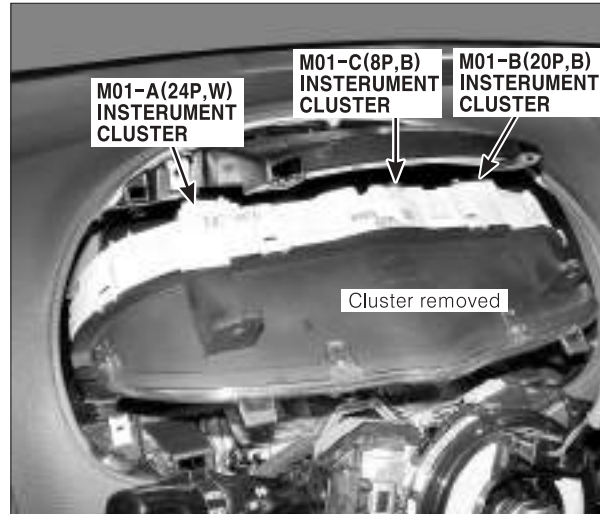

PHOTO.63

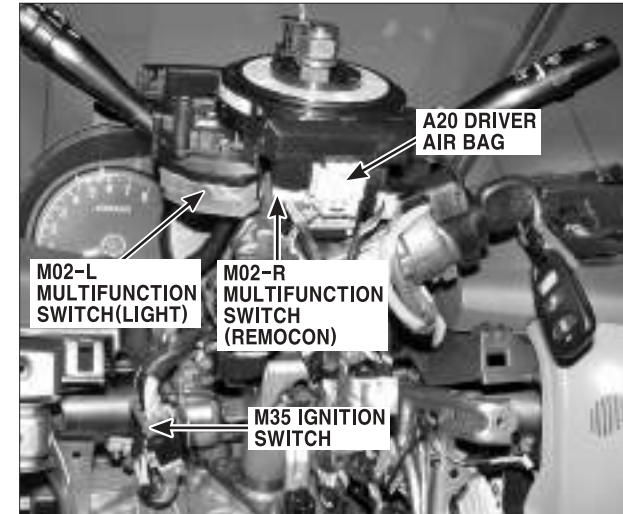

PHOTO.64

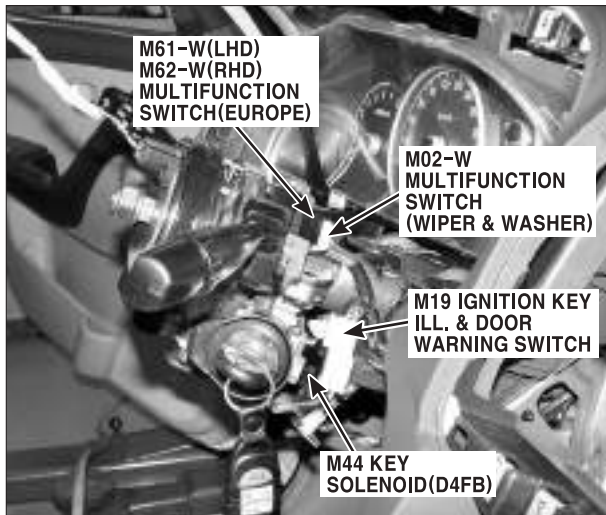

PHOTO.65

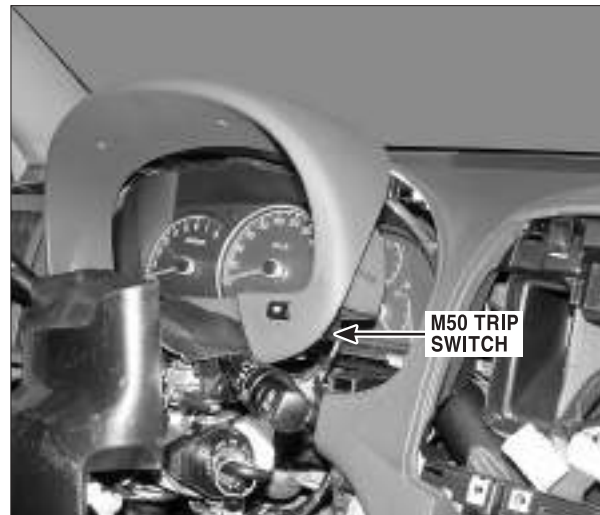
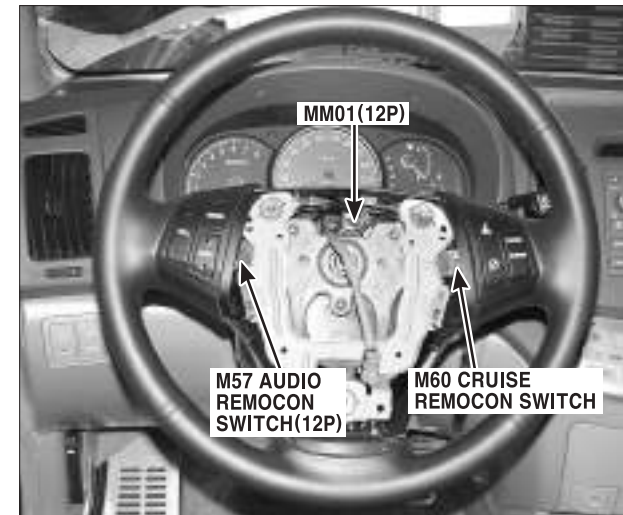

PHOTO.66



COMPONENT LOCATIONS

COMPONENT LOCATIONS(12)

CL-12

PHOTO.67

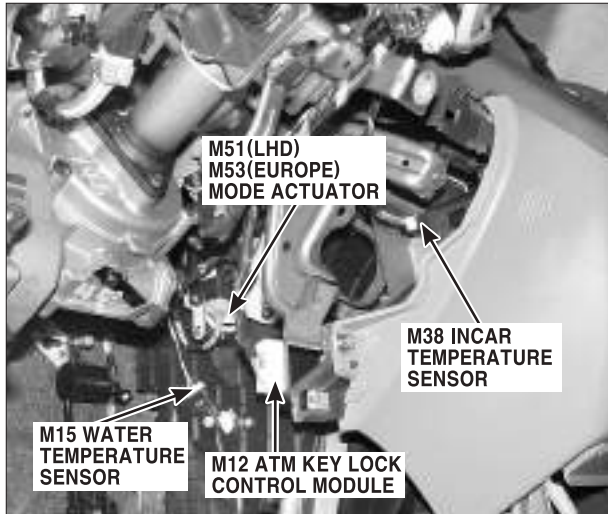

PHOTO.68

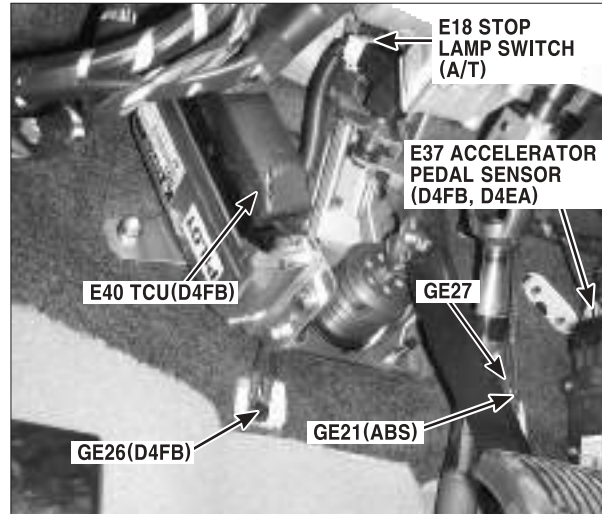

PHOTO.69

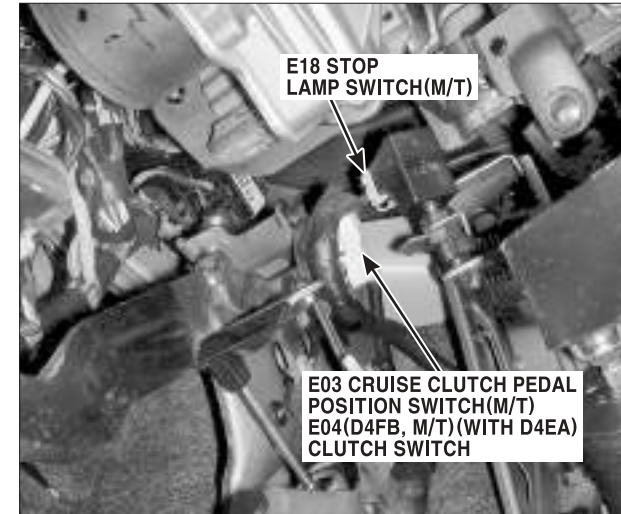

PHOTO.70

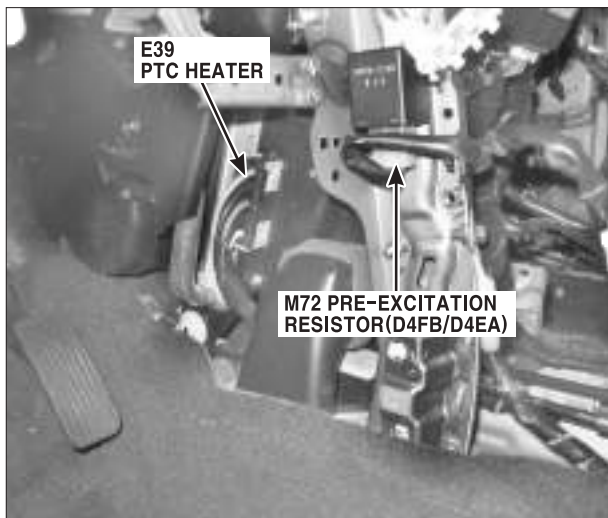

PHOTO.71

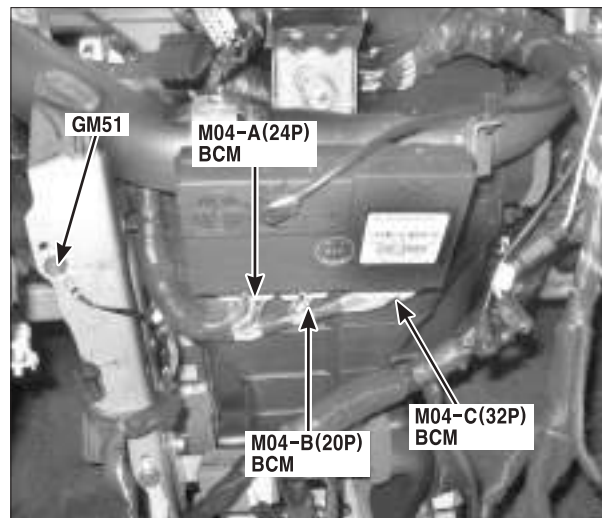
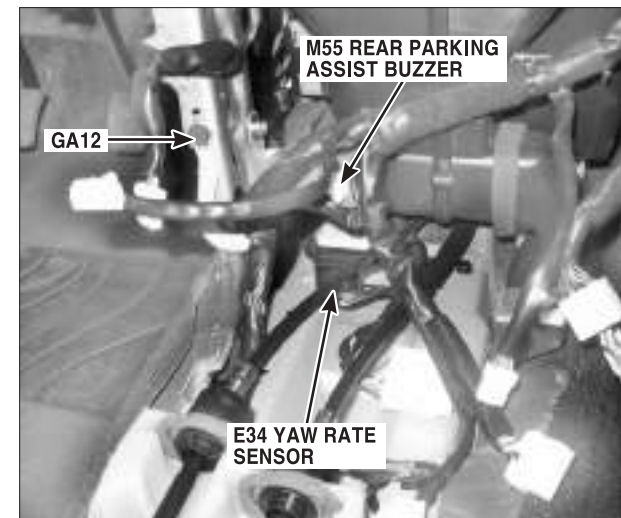

PHOTO.72



COMPONENT LOCATIONS

COMPONENT LOCATIONS(13)

CL-13

PHOTO.73

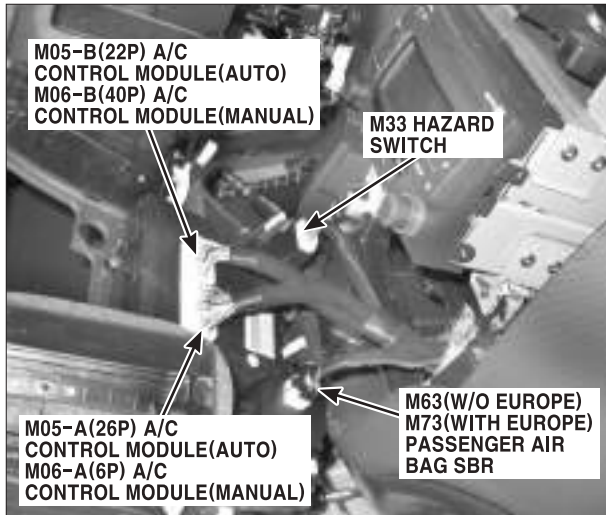

PHOTO.74

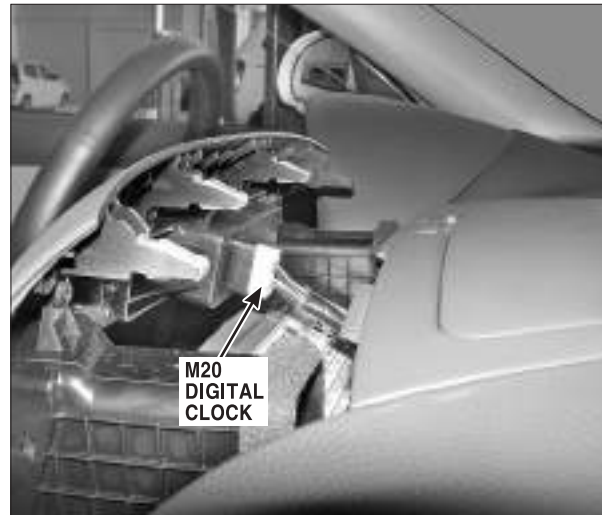

PHOTO.75

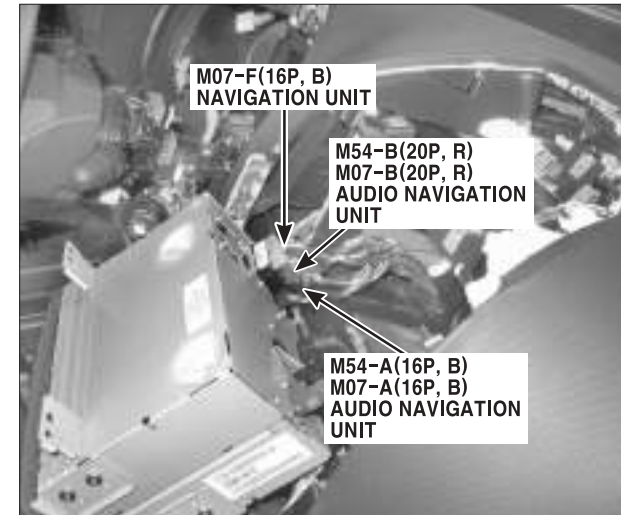

PHOTO.76

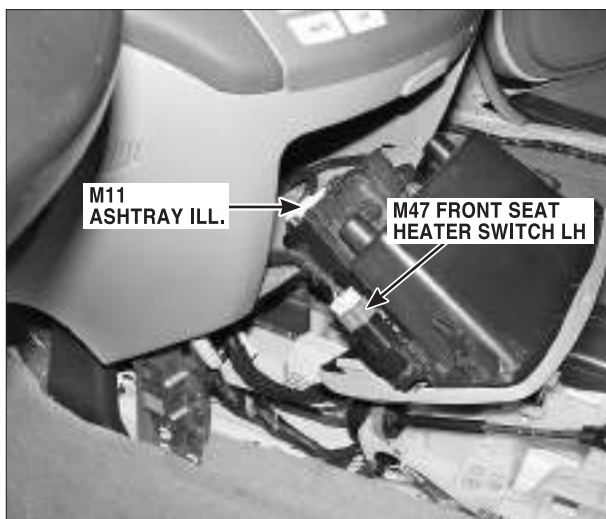
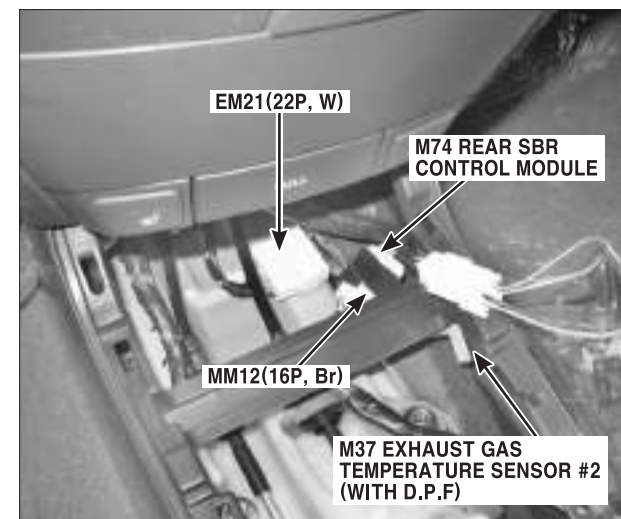

PHOTO.77



PHOTO.78



COMPONENT LOCATIONS

COMPONENT LOCATIONS(14)

CL-14

PHOTO.79



PHOTO.80



PHOTO.81

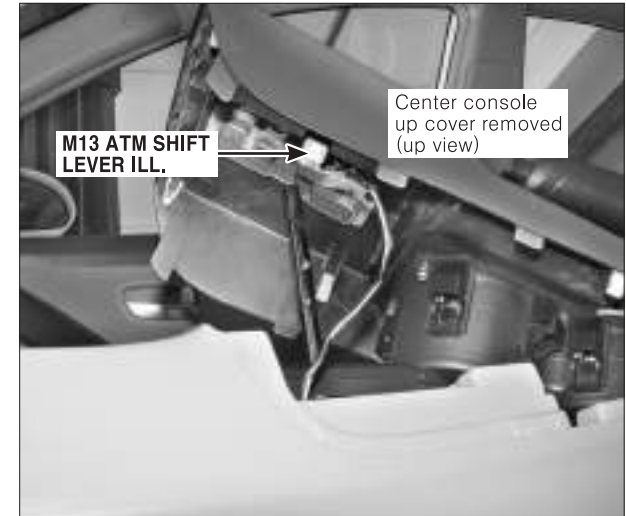

PHOTO.82

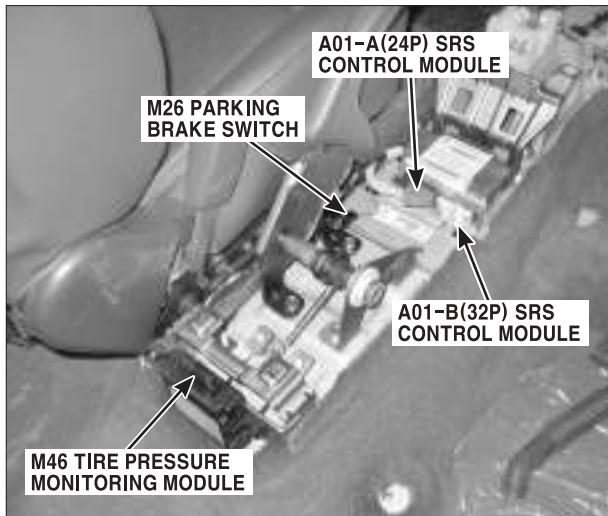

PHOTO.83

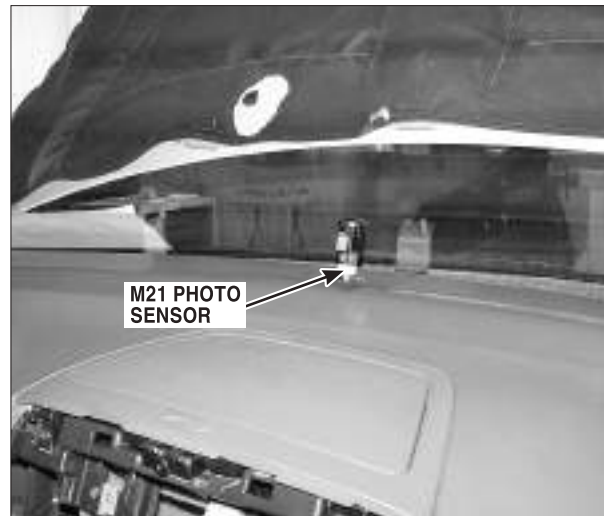
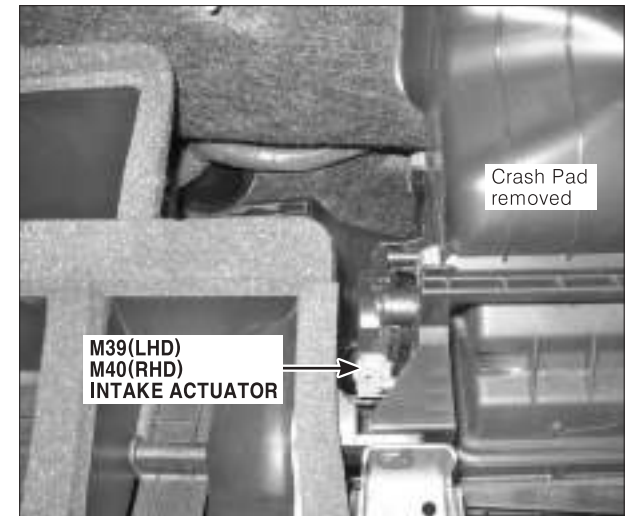

PHOTO.84



COMPONENT LOCATIONS

COMPONENT LOCATIONS(15)

CL-15

PHOTO.85

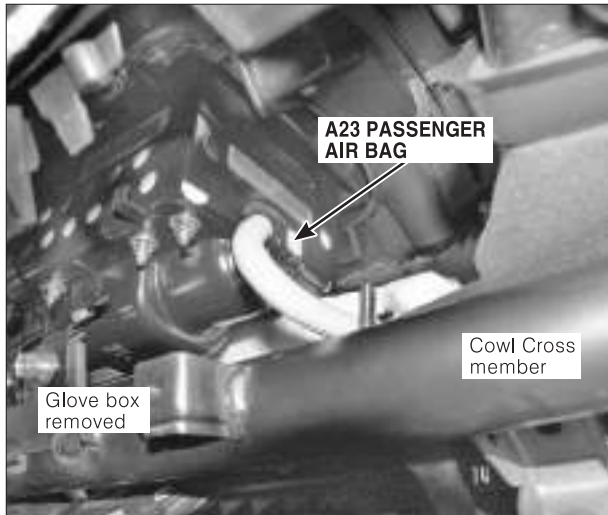

PHOTO.86

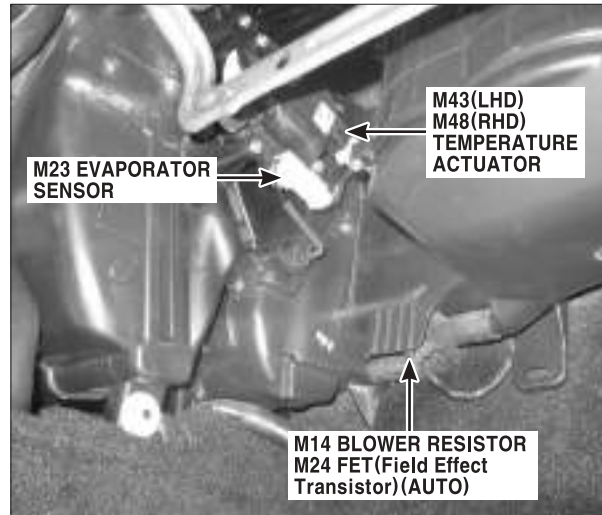

PHOTO.87

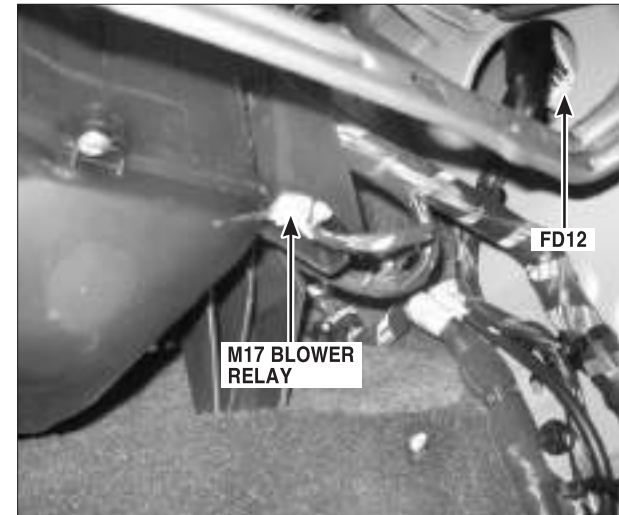

PHOTO.88

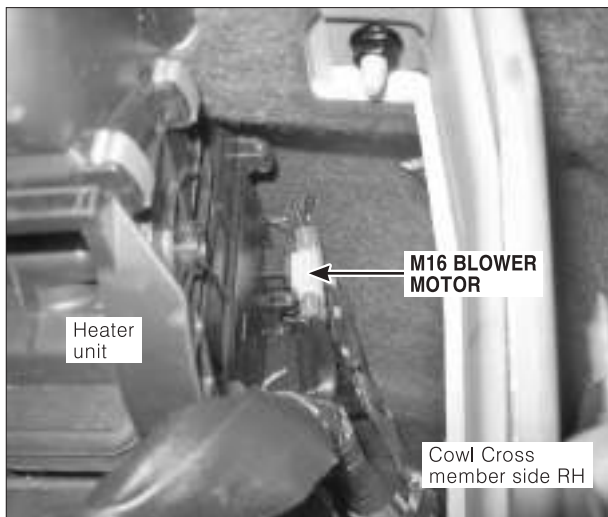

PHOTO.89

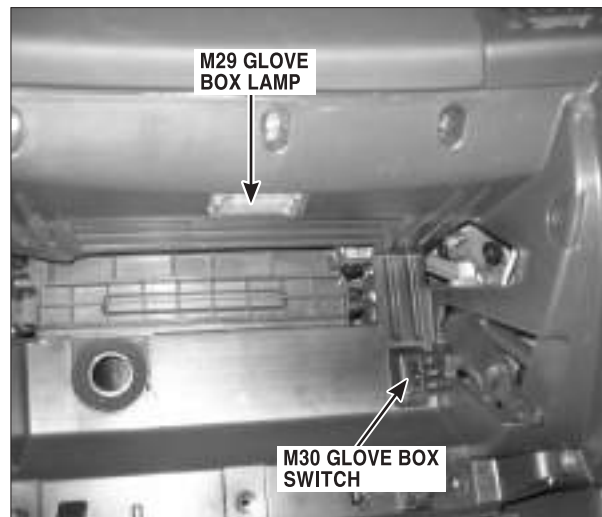

PHOTO.90



COMPONENT LOCATIONS

COMPONENT LOCATIONS(16)

CL-16

PHOTO.91

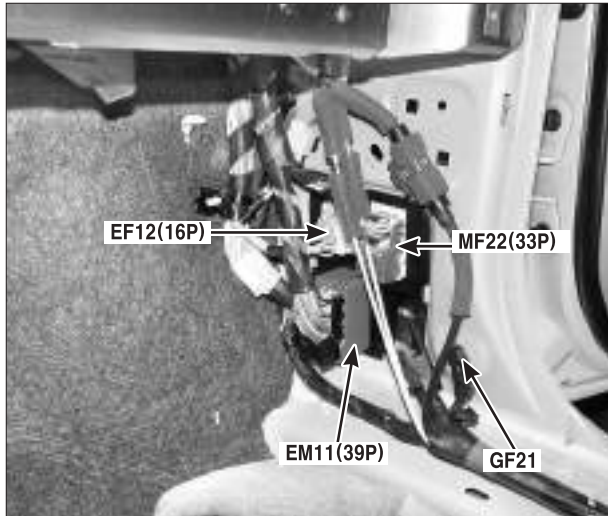

PHOTO.92



PHOTO.93

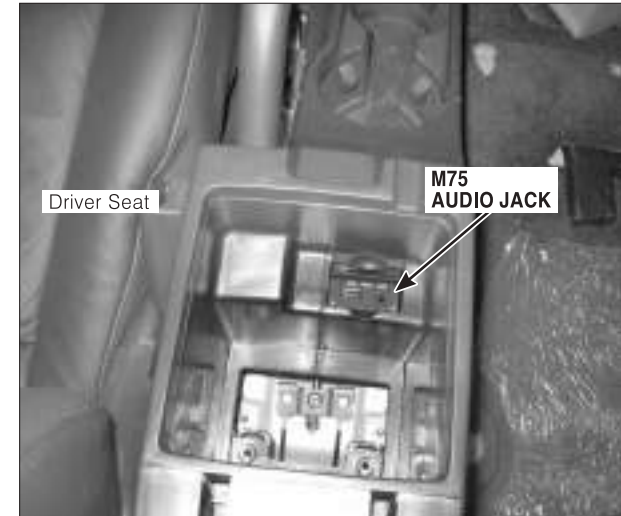

PHOTO.94

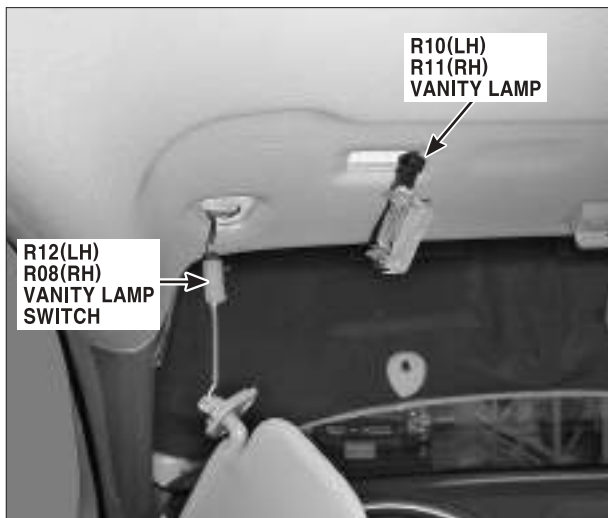

PHOTO.95

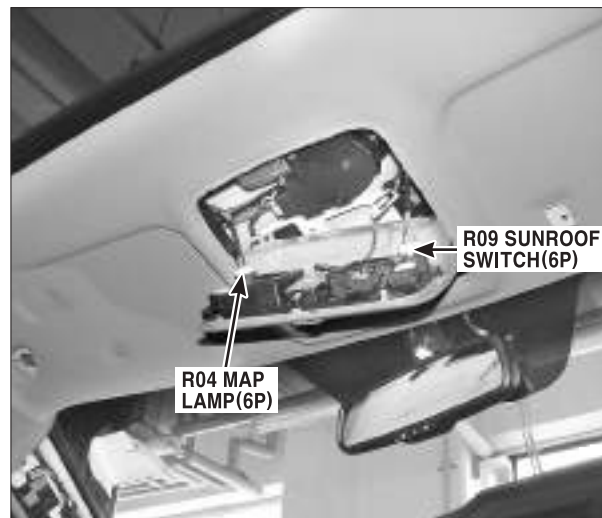
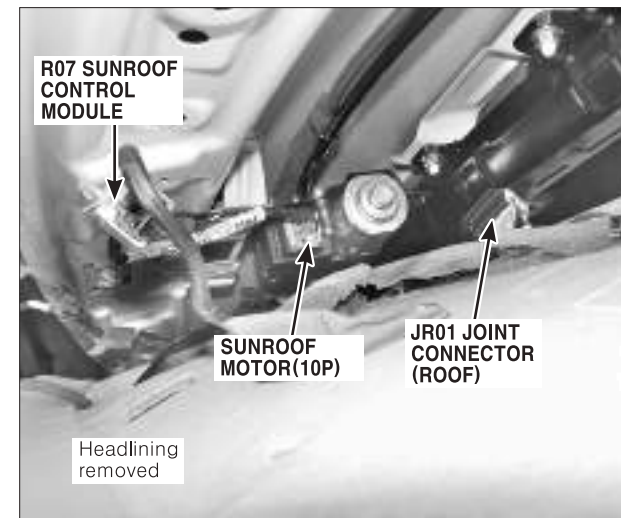

PHOTO.96



COMPONENT LOCATIONS

COMPONENT LOCATIONS(17)

CL-17

PHOTO.97

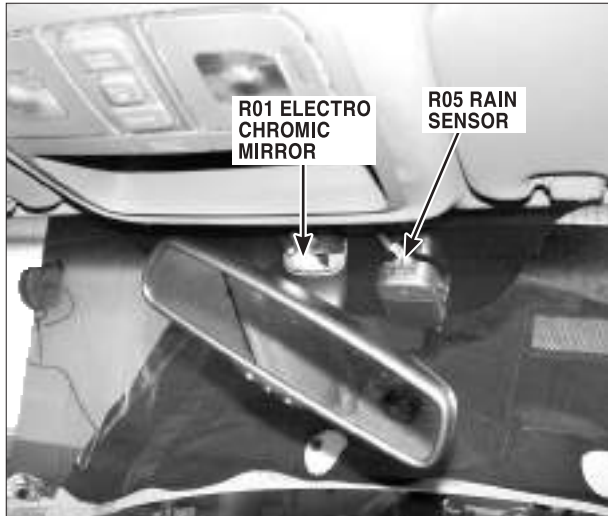

PHOTO.98

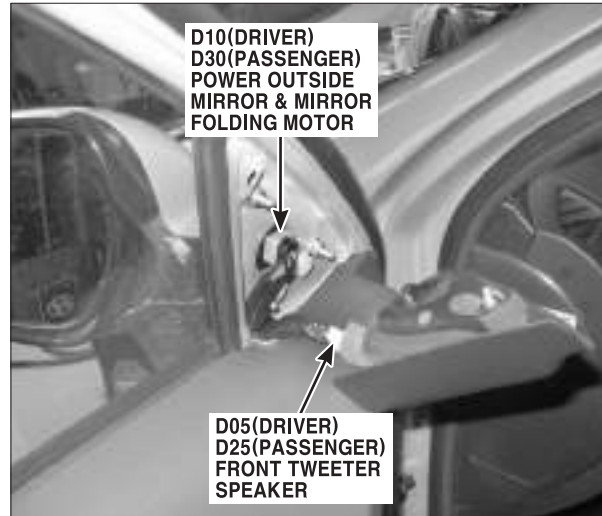

PHOTO.99

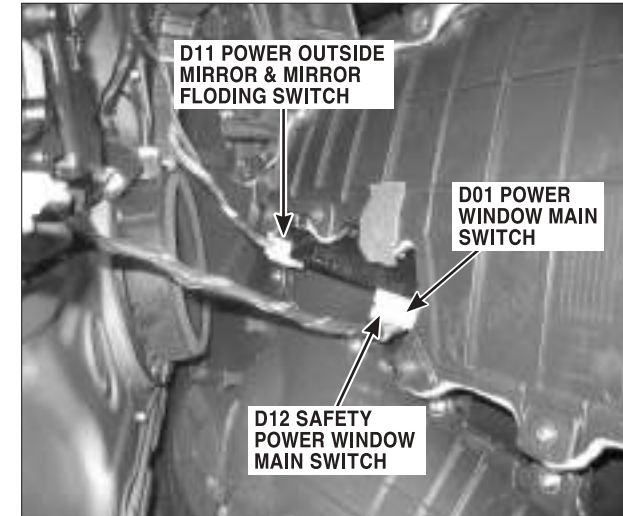

PHOTO.100

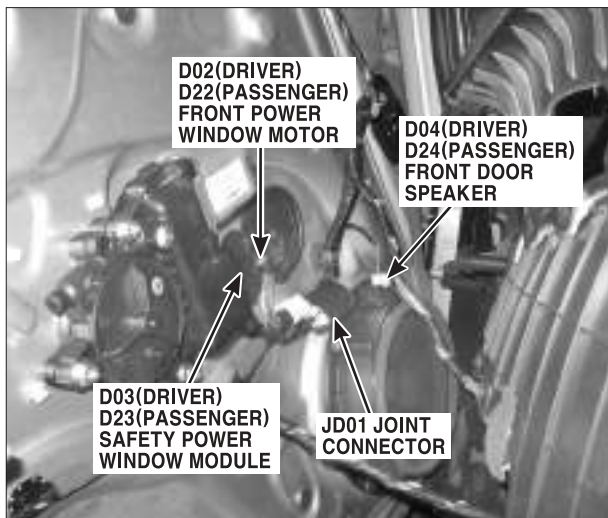

PHOTO.101



PHOTO.102



COMPONENT LOCATIONS

COMPONENT LOCATIONS(18)

CL-18

PHOTO.103

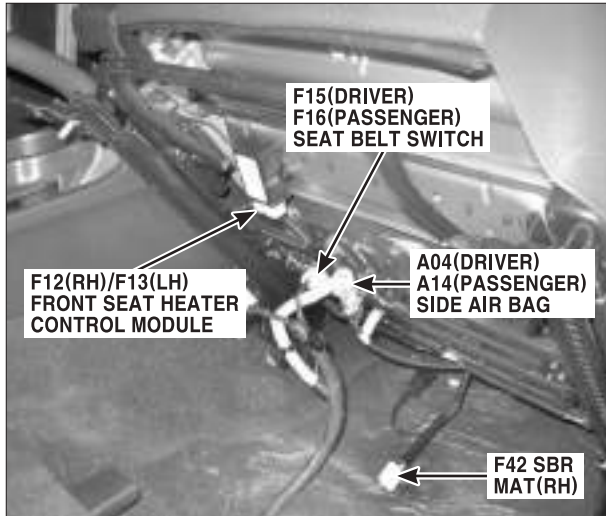

PHOTO.104

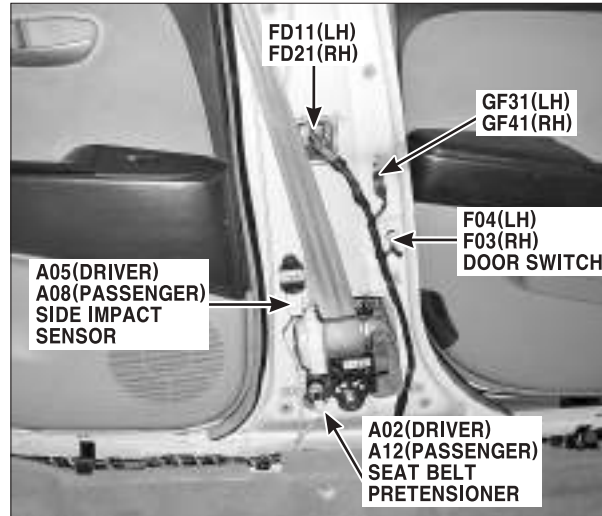

PHOTO.105

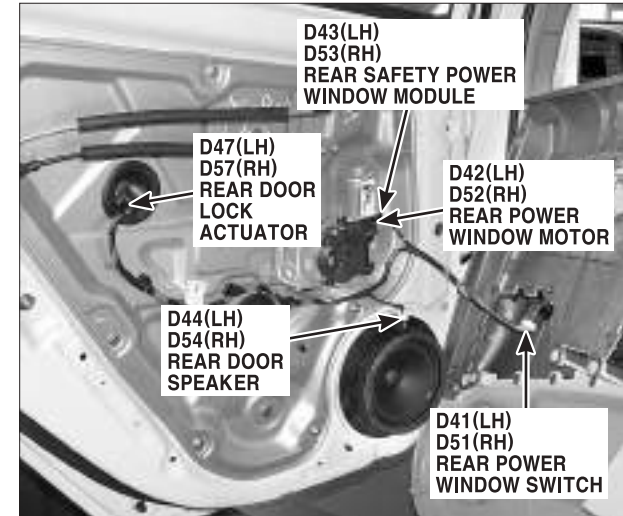

PHOTO.106



PHOTO.107

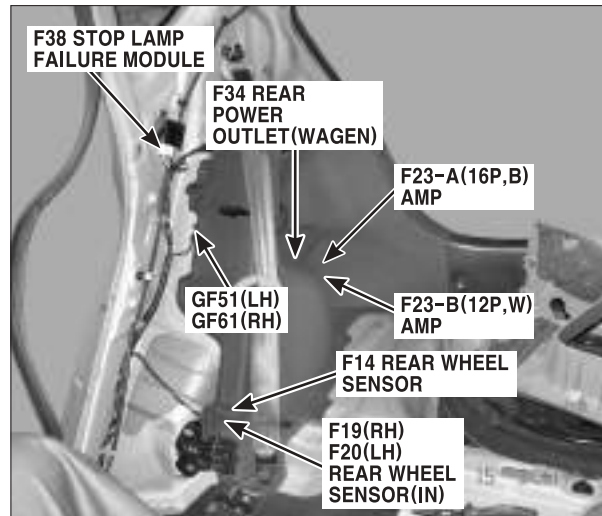
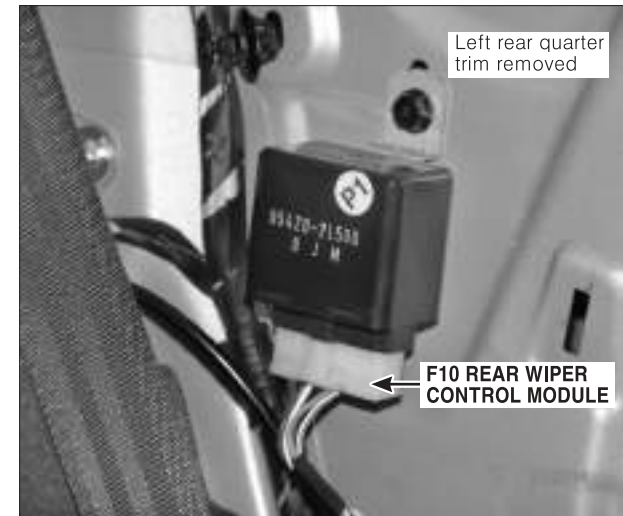

PHOTO.108



COMPONENT LOCATIONS

COMPONENT LOCATIONS(19)

CL-19

PHOTO.109

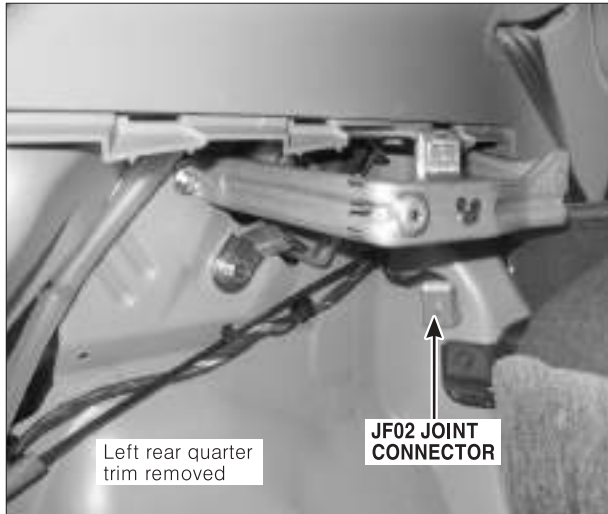

PHOTO.110

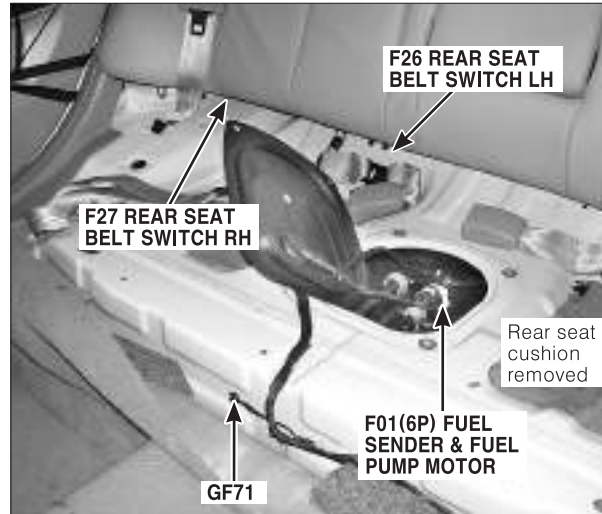

PHOTO.111

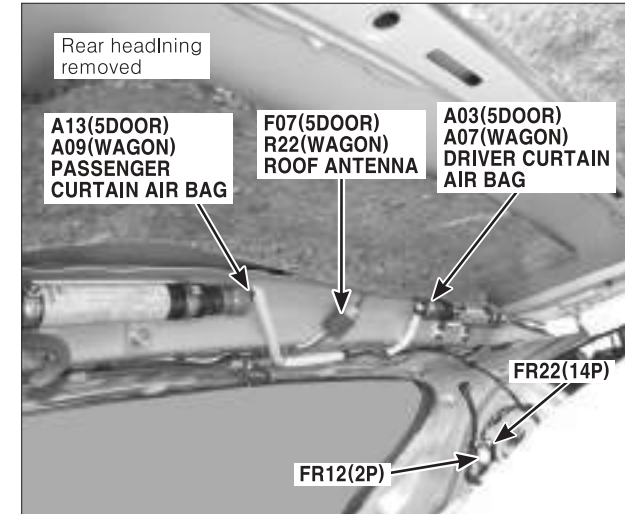

PHOTO.112

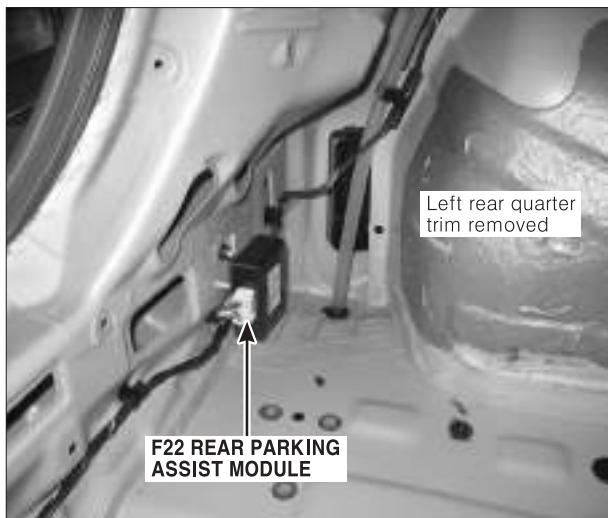

PHOTO.113

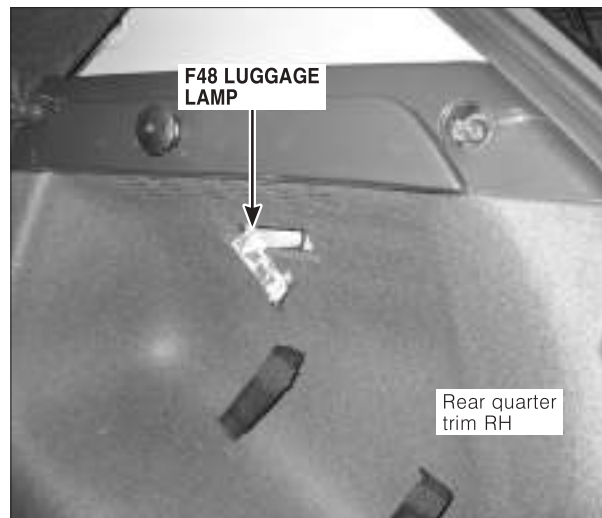

PHOTO.114



COMPONENT LOCATIONS

COMPONENT LOCATIONS(20)

CL-20

PHOTO.115

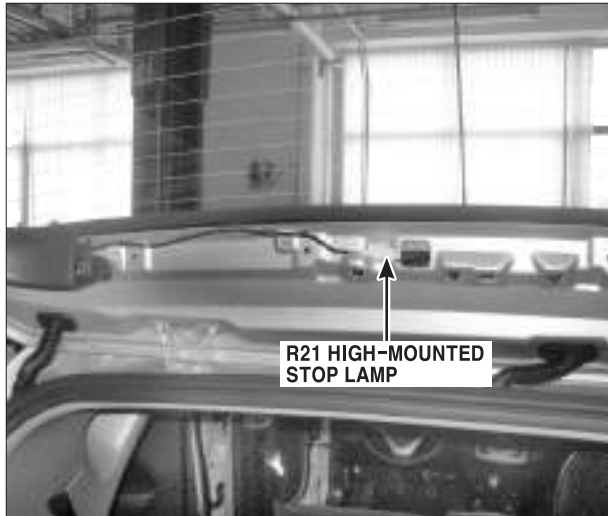

PHOTO.116



PHOTO.117

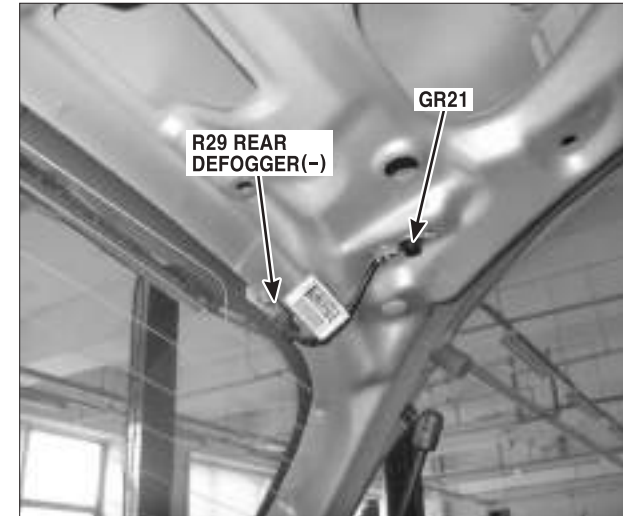

PHOTO.118

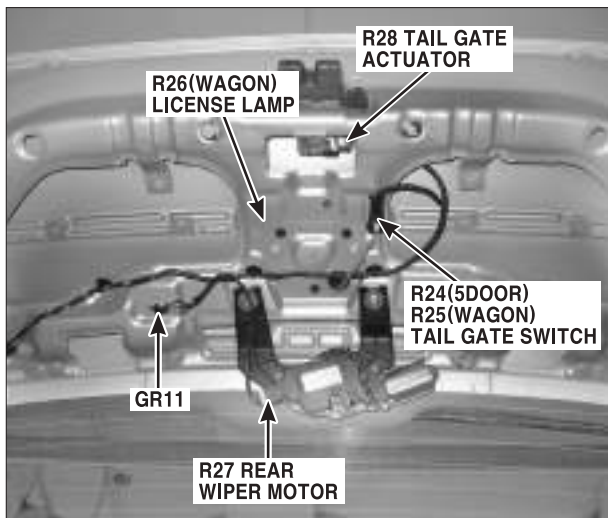

PHOTO.119

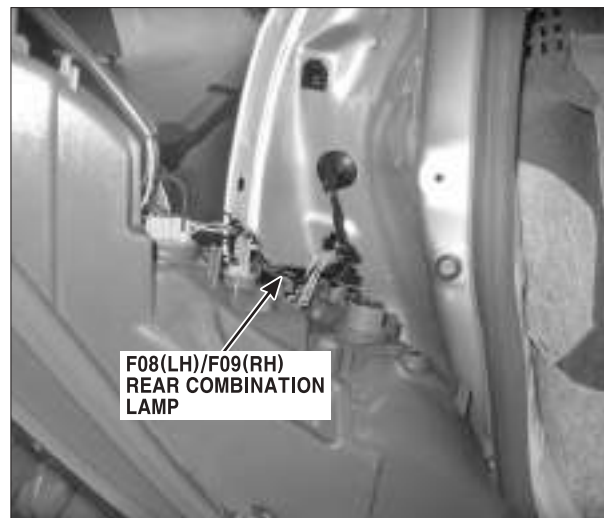
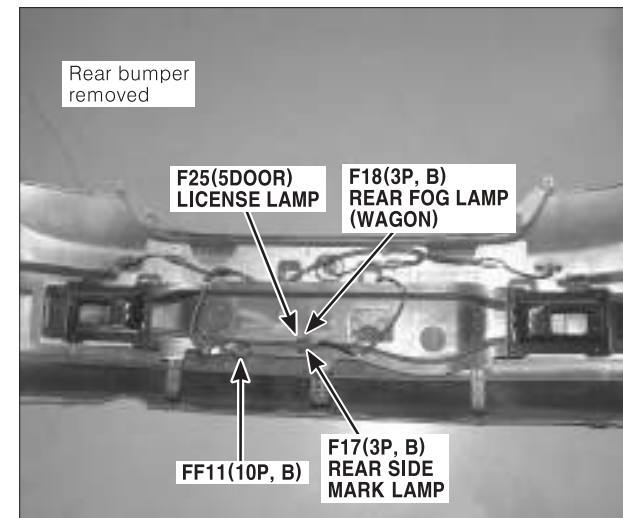

PHOTO.120



COMPONENT LOCATIONS

COMPONENT LOCATIONS(21)

CL-21

PHOTO.121



HARNESS CONNECTORS

E11D5D16

HARNESS CONNECTORS (1)

CC-1

CGGIG

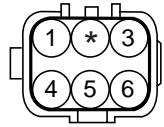

KUM_NMWP_06M_5



KUM_NMWP_06F_B

CGGMT

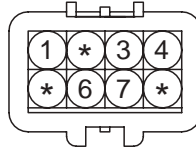

KUM_NMWP_08M_B

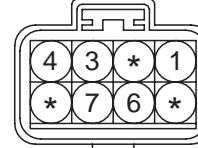

KUM_NMWP_08F_B

CBGINJ

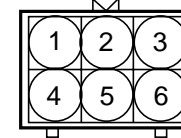

CR06M010

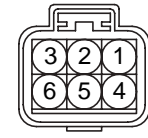

KUM_NMWP_06F_B

CBGMT

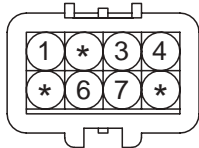

KUM_NMWP_08M_B

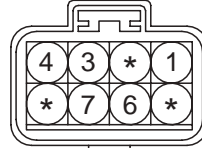

KUM_NMWP_08F_B

CUDMT

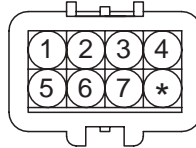

KUM_NMWP_08M_B

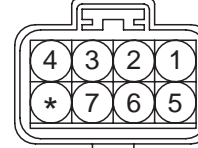

KUM_NMWP_08F_B

CDDMT

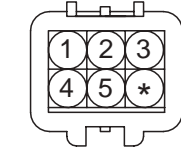

KUM_NMWP_06M_B

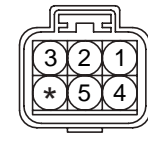

KUM_NMWP_06F_B

EB11

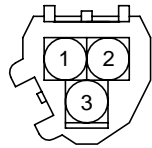

KUM_NMWP_03M_B

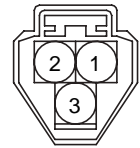

KUM_NMWP_03F_B

EC21

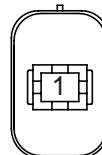

AMP_312WP_01M_B

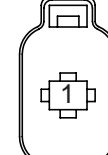

AMP_312WP_01F_B

EE12



KET_SSD_16M_B



KET_SSD_16F_B

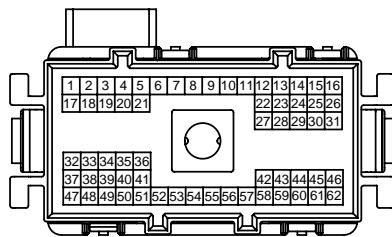

AMP_090_62M_B

EC11

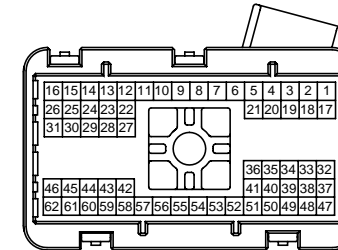

AMP_090_62F_B

EF12

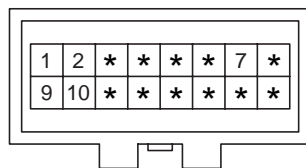

AMP_090III_16M_W

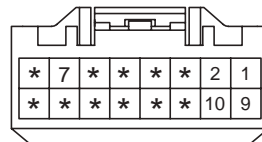

AMP_090III_16F_W

EM11

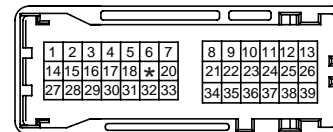

KET_LIF0409_39M_Gr

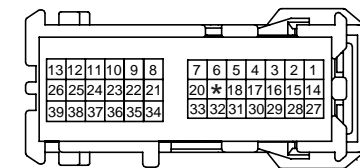

KET_LIF0409_39F_Gr

HARNES CONNECTORS

HARNES CONNECTORS (2)

CC-2

EM21

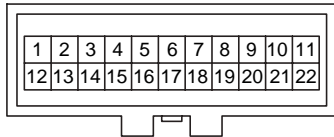

AMP_090III_22M_W

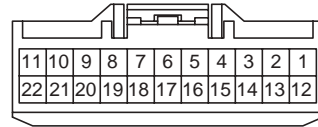

AMP_090III_22F_W

EM31

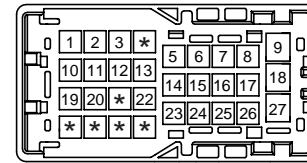

KET_LIF187_31M_W

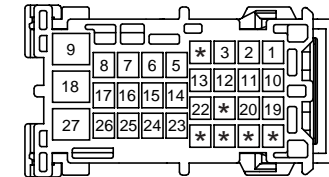

KET_LIF187_31F_W

FD11

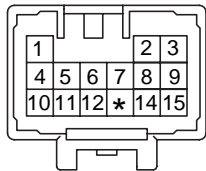

KET_090III_15M_W

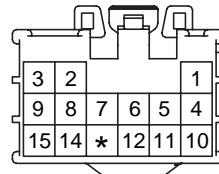

KET_090III_15F_W

FD12

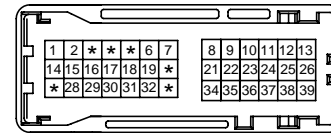

KET_LIF0409_39M_W_DR

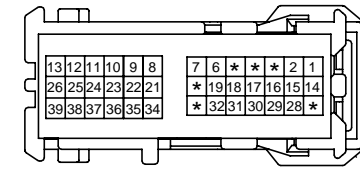

KET_LIF0409_39F_W

FD21

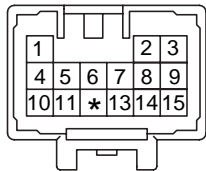

KET_090III_15M_W

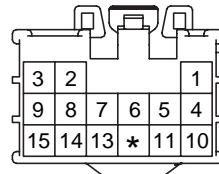

KET_090III_15F_W

FD22

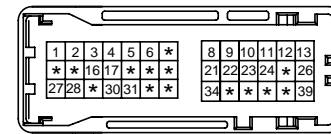

KET_LIF0409_39M_W_DR

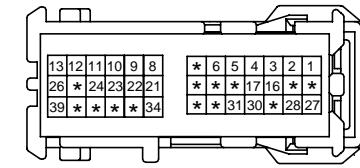

KET_LIF0409_39F_W

FF11

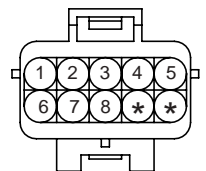

AMP_EJWP_10M_B

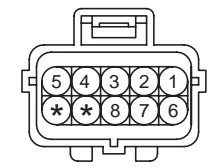

AMP_EJWP_10F_B

FR11

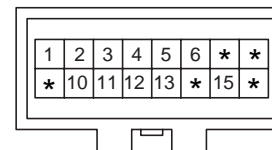

AMP_090III_16M_W

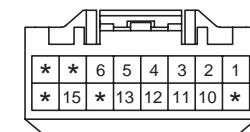

AMP_090III_16F_W

FR12

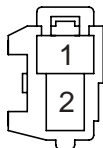

KUM_DSD_02M_W_CL_1P



KUM_DSD_02F_W

FR22

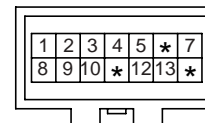

AMP_090III_14M_W

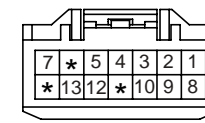

AMP_090III_14F_W

HARNESS CONNECTORS

HARNESS CONNECTORS (3)

CC-3

MF12

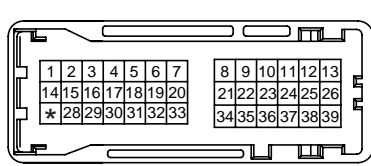

KET_LIF0409_39M_Gr

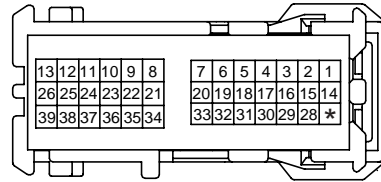

KET_LIF0409_39F_Gr

MF22

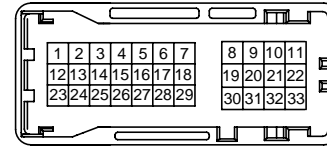

KET_LIF0409_33M_W

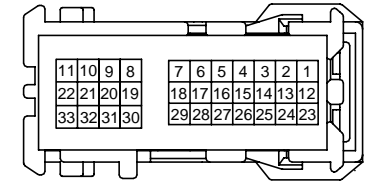

KET_LIF0409_33F_W

MM01

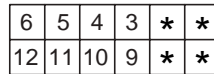

CR12F031

MM12

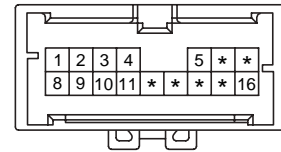

KET_040III_16M_Br

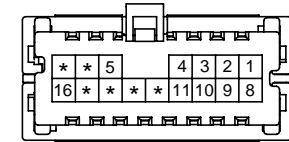

KET_040III_16F_Br

ENGINE COMPARTMENT JUNCTION BOX (1)

CC-4

E/R-CGG(G4FC)

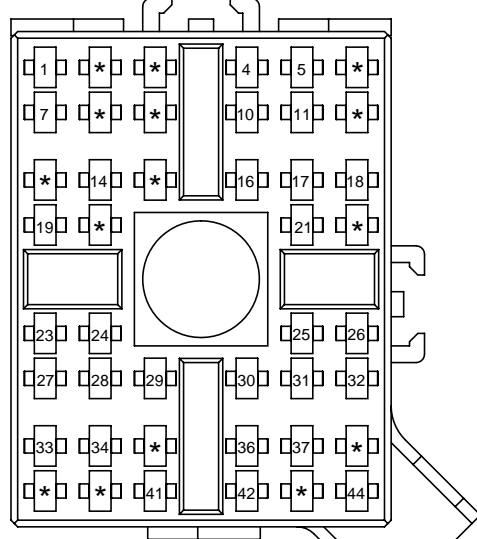

AMP_UHBOX_44F_B

E/R-CBG(G4GC)

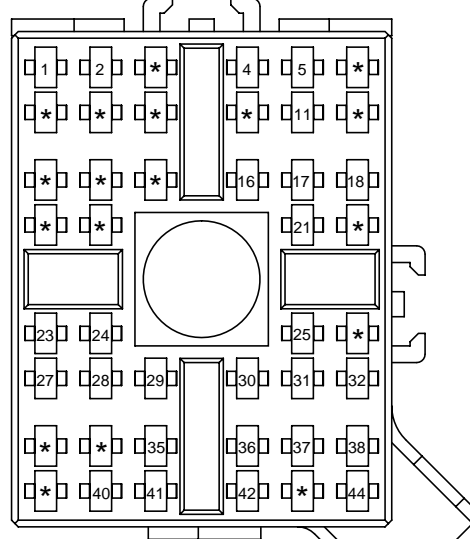

AMP_UHBOX_44F_B

E/R-CUD(D4FB)

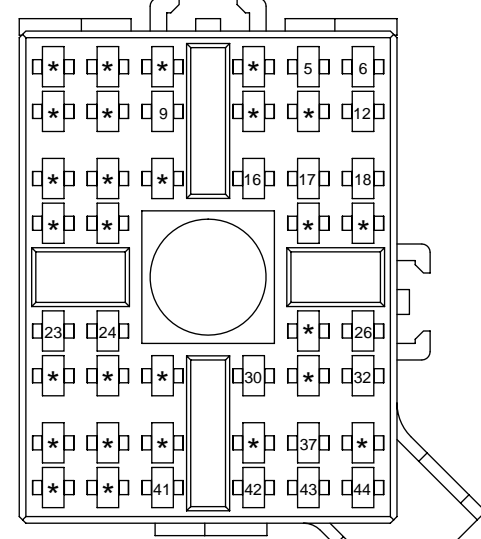

AMP_UHBOX_44F_B

E/R-CDD(D4EA)

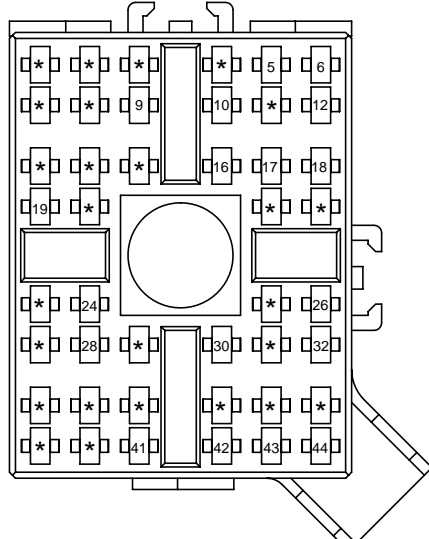

AMP_UHBOX_44F_B

E/R-EROM

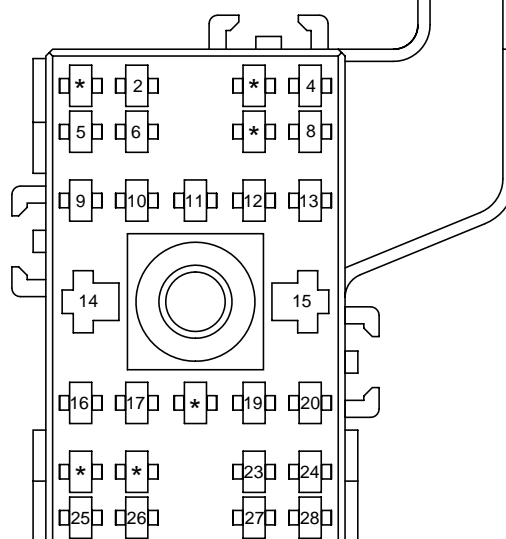

AMP_UHBOX_28F_B

E/R-FRT

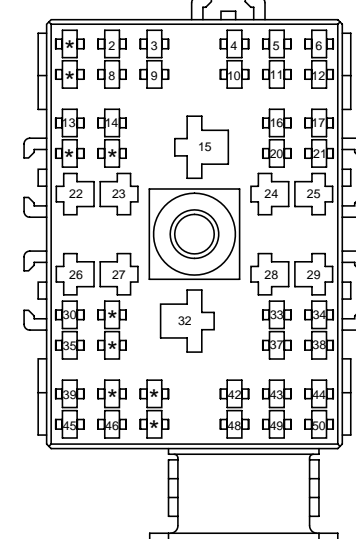

AMP_UHBOX_50F_B

PASSENGER COMPARTMENT JUNCTION BOX & JOINT CONNECTORS E82D8F64

PASSENGER COMPARTMENT JUNCTION BOX & JOINT CONNECTORS (1)

CC-5

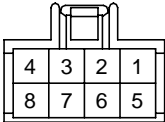
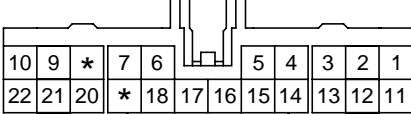
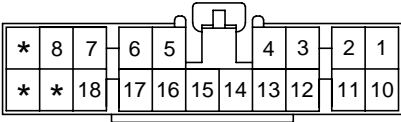
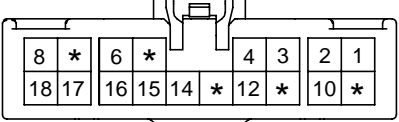
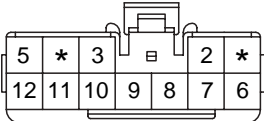
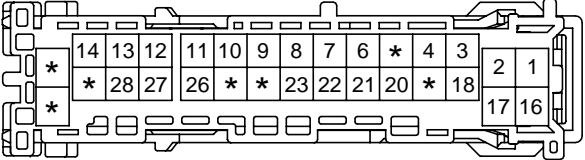
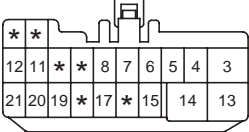
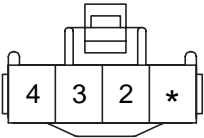
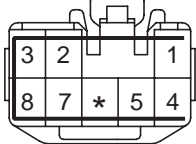
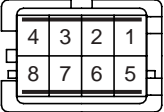
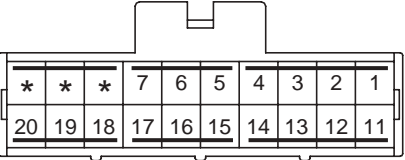
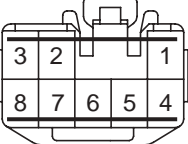
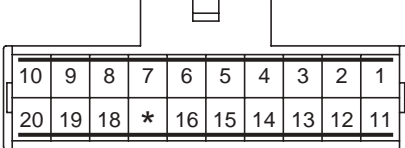
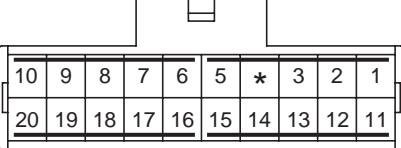
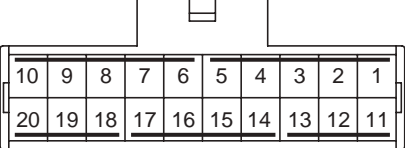
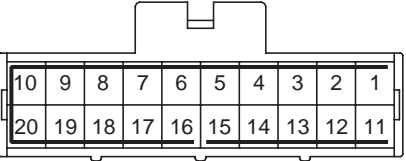
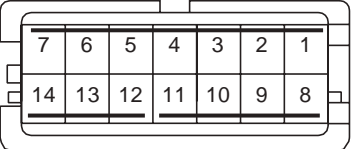
<p>I/P-A</p>  <p>KET_187II_08F_W</p>	<p>I/P-B</p>  <p>KET_090III_22F_W</p>	<p>I/P-C</p>  <p>KET_090III_20F_W</p>	<p>I/P-D</p>  <p>KET_090III_18F_W</p>
<p>I/P-E</p>  <p>KET_090II_12F_W</p>	<p>I/P-F</p>  <p>KET_LIF09187_30F_W</p>		<p>I/P-G</p>  <p>KET_1809_21F_W_A</p>
<p>I/P-H</p>  <p>KET_312II_04F_W</p>	<p>JD01</p>  <p>KET_090II_08F_W</p>	<p>JE01</p>  <p>KET_070_08F_W_JCH</p>	<p>JF01</p>  <p>KET_090II_20F_B_JCH</p>
<p>JF02</p>  <p>KET_090II_08F_W</p>	<p>JM01</p>  <p>KET_090II_20F_B_JCH</p>	<p>JM02</p>  <p>KET_090II_20F_B_JCH</p>	<p>JM03</p>  <p>KET_090II_20F_B_JCH</p>
<p>JM04</p>  <p>KET_090II_20F_B_JCH</p>	<p>JR01</p>  <p>KET_070_14F_B_JCH</p>	<p>BLANK</p>	<p>BLANK</p>

MAIN HARNESS (1)

HL-1

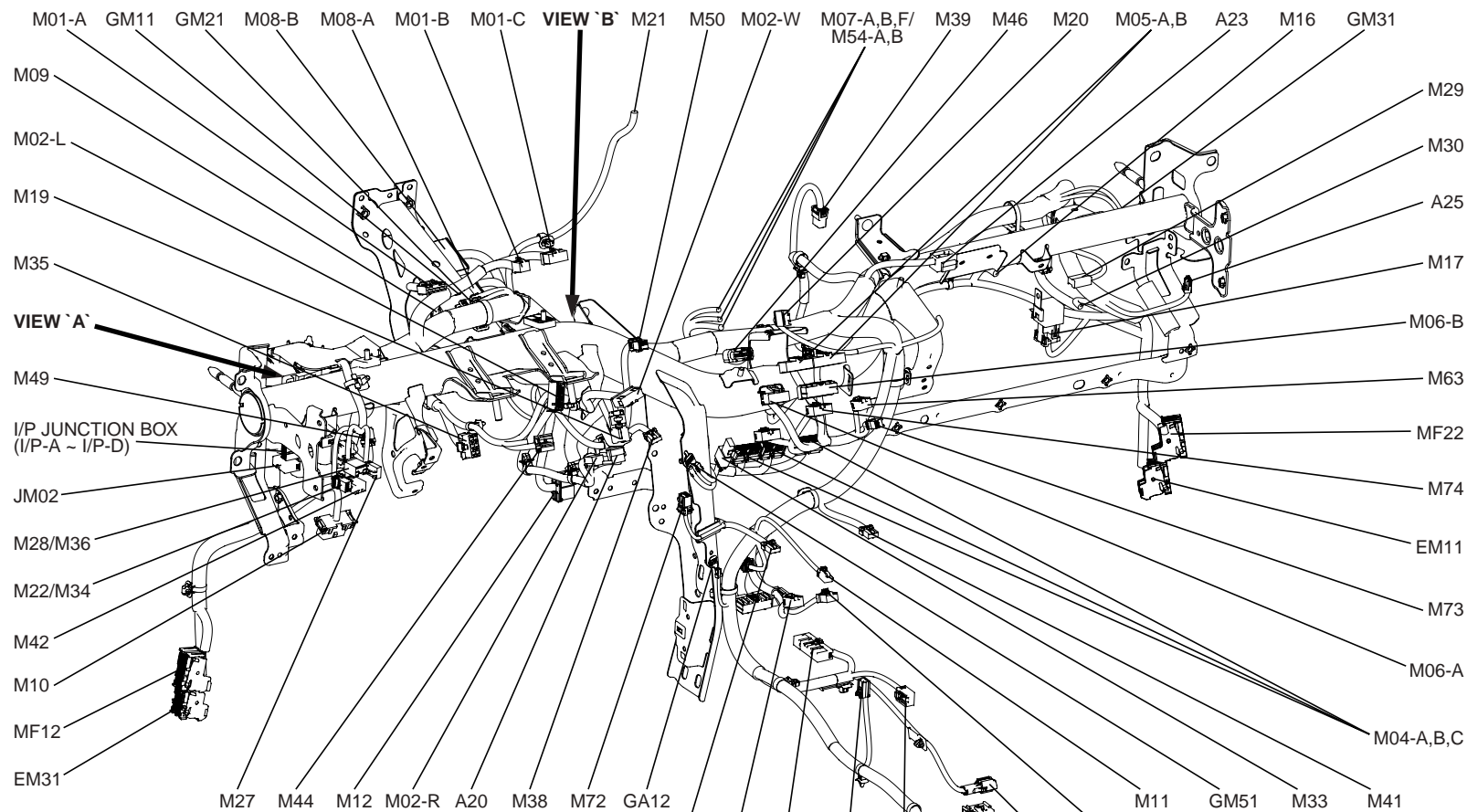

VIEW 'A'

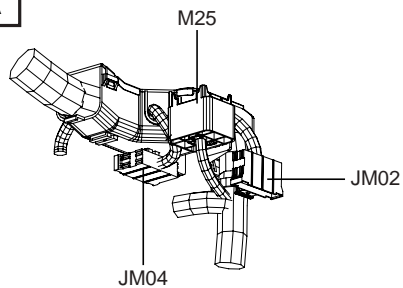

VIEW 'B'

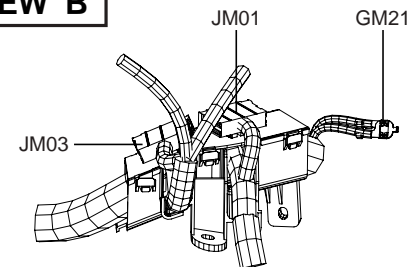

M47 M18 EM21 M13 M45 A01-A M26 M46

MAIN HARNESS

MAIN HARNESS (2)

HL-2

MAIN HARNESS

M01-A	Instrument Cluster	M27	Rheostat
M01-B	Instrument Cluster	M28	Windshield Defogger Switch(W/O ESP)
M01-C	Instrument Cluster	M29	Glove Box Lamp
M02-L	Multifunction Switch(LHD)	M30	Glove Box Switch
M02-R	Multifunction Switch	M33	Hazard Switch
M02-W	Multifunction Switch(LHD)	M34	Head Lamp Leveling Switch
M03-L	Multifunction Switch(RHD)	M35	Ignition Switch
M03-W	Multifunction Switch(RHD)	M36	ESP Switch(With Windshield Defogger)
M04-A	BCM	M37	Exhaust Gas Temperature Sensor #2 (With D.P.F)
M04-B	BCM	M38	Incar Temperature Sensor
M04-C	BCM	M39	Intake Actuator(LHD)
M05-A	A/C Control Module(Auto)	M40	Intake Actuator(RHD)
M05-B	A/C Control Module(Auto)	M41	Front Seat Heater Switch RH
M06-A	A/C Control Module(Manual)	M42	Windshield Defogger Switch(With ESP)
M06-B	A/C Control Module(Manual)	M43	Temperature Actuator(LHD)
M07-A	Navigation Unit	M44	Key Solenoid
M07-B	Navigation Unit	M45	ATM Shift Lever Switch
M07-F	Navigation Unit	M46	Tire Pressure Monitoring Module
M08-A	ICM Relay Box	M47	Front Seat Heater Switch LH
M08-B	ICM Relay Box	M48	Temperature Actuator(RHD)
M09	Immobilizer Module	M49	EPS Control Module
M10	Data Link Connector	M50	Trip Switch
M11	Ashtral ILL.	M51	Mode Actuator(LHD)
M12	ATM Key Lock Control Module	M52	Mode Actuator(RHD)
M13	ATM Shift Lever ILL.	M53	Mode Actuator(With Europe)
M14	Blower Resistor	M54-A	Audio
M15	Water Temperature Sensor(Auto)	M54-B	Audio
M16	Blower Motor	M55	Rear Parking Assist Buzzer
M17	Blower Relay	M61-W	Multifunction Switch(LHD)(With Europe)
M18	Power Outlet	M62-W	Multifunction Switch(RHD)(With Europe)
M19	Ignition Key ILL. & Door Warning Switch	M63	Passenger Air Bag SBR(W/O Europe)
M20	Digital Clock	M72	Pre-excitation Resistor(D4FB/D4EA)
M21	Photo Sensor	M73	Passenger Air Bag SBR(With Europe)
M22	ESP Switch	M74	Rear SBR Control Module
M23	(W/O Windshield Defogger) Evaporator Sensor	JM01	Joint Connector
M24	FET(Field Effect Transistor)	JM02	Joint Connector
M25	Flasher Unit	JM03	Joint Connector
M26	Parking Brake Switch	JM04	Joint Connector
		EM11	Connection With ENGINE ROOM Harness

EM21	Connection With ENGINE ROOM Harness
EM31	Connection With FRONT Harness
I/P-A	Connection With I/P JUNCTION BOX Harness
I/P-B	Connection With I/P JUNCTION BOX Harness
I/P-C	Connection With I/P JUNCTION BOX Harness
I/P-D	Connection With I/P JUNCTION BOX Harness
MF12	Connection With FLOOR Harness
MF22	Connection With FLOOR Harness
MM12	Connection With CONSOLE EXT. Harness
GM11	Ground
GM21	Ground
GM31	Ground
GM51	Ground

STEERING REMOCON HARNESS

M57	Audio Remocon Switch
M60	Cruise Remocon Switch
MM01	Connection With Steering Remocon Harness

CONSOLE EXT. HARNESS

M75	Audio Jack
MM12	Connection With MAIN Harness

AIR BAG EXT. HARNESS

A01-A	SRS Control Module
A20	Driver Air Bag
A23	Passenger Air Bag
A25	PAD Switch
I/P-E	Connection With I/P JUNCTION BOX Harness
GA12	Ground

ENGINE ROOM HARNESS (1)

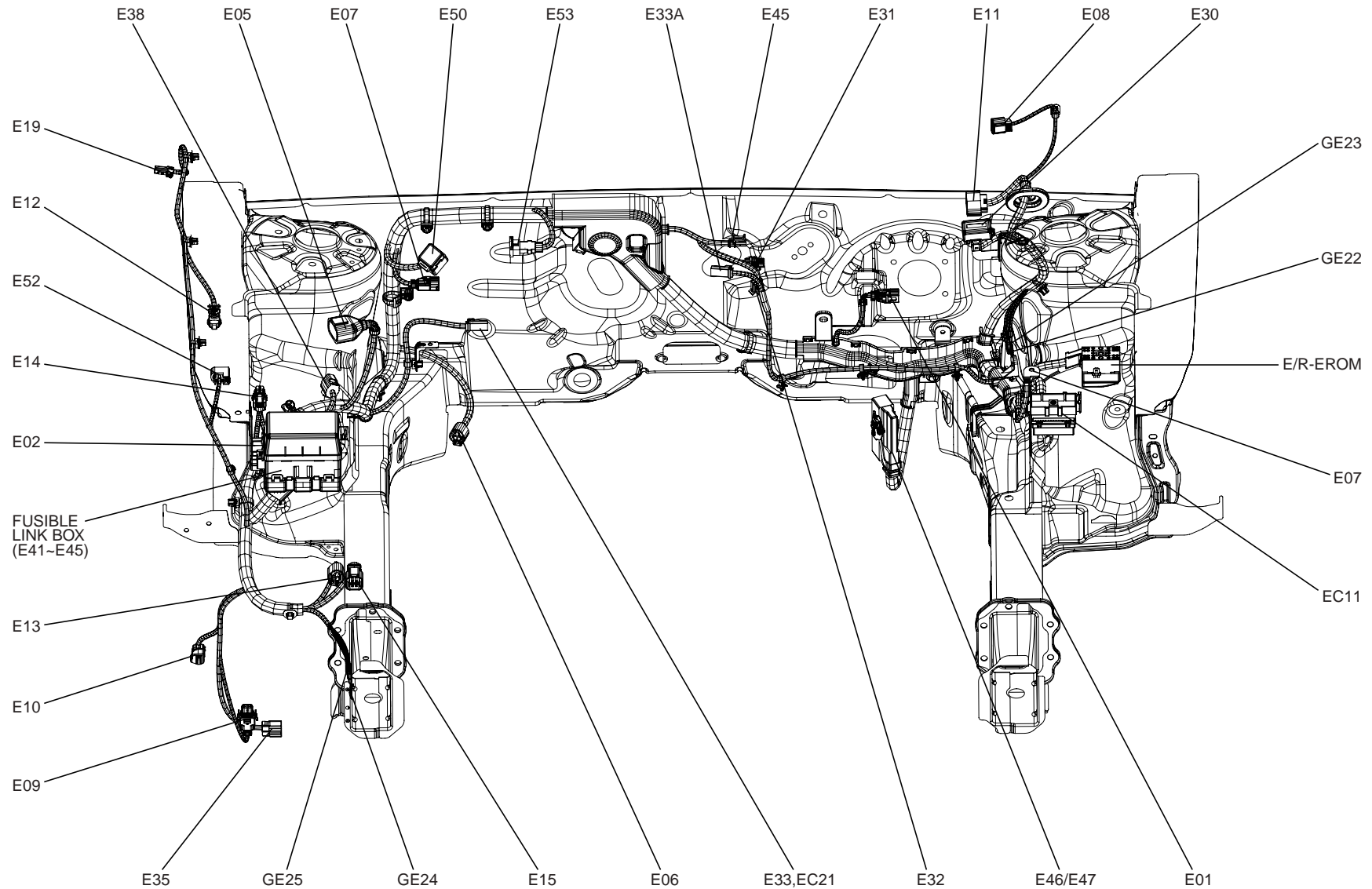

ENGINE ROOM HARNESS

ENGINE ROOM HARNESS (2)

HL-4

ENGINE ROOM HARNESS

E01	Brake Fluid Level Sensor	JE01	Joint Connector
E02	Burglar Alarm Horn	EC11	Connection with CONTROL harness
E03	Cruise Clutch Pedal Position Switch(M/T)(W/O D4EA)	EC21	Connection with CONTROL harness(D4FB)
E04	Clutch Switch(D4FB.M/T)(With D4EA)	EF12	Connection with FLOOR harness
E05	Cruise Control Module(G4GC ONLY)	EM11	Connection with MAIN harness
E07	Differential Pressure Sensor	EM21	Connection with MAIN harness
E08	Windshield Defogger	E/R-EROM	Connection with E/R JUNCTION BOX harness
E09	Front Fog Lamp RH	GE21	Ground
E10	Washer Motor	GE22	Ground
E11	Front Wiper Motor	GE23	Ground
E12	Front Wheel Sensor RH	GE24	Ground
E13	Head Lamp Leveling Actuator RH	GE25	Ground
E14	Hood Switch	GE26	Ground
E15	Head Lamp RH	GE27	Ground
E16	Ignition Lock Switch(RHD ONLY)		
E18	Stop Lamp Switch		
E19	Side Repeater Lamp RH		
E30	Multipurpose Check Connector		
E31	Fuel Filter Heater(D4FB/D4EA)		
E32	Fuel Filter Warning Switch(D4FB/D4EA)		
E33	Glow Plug(D4FB)		
E33A	Glow Plug(D4EA)		
E34	Yaw Rate Sensor		
E35	Washer Level Sensor		
E36	Fuel Filter Sensor(D4FB/D4EA)		
E37	Accelerator Pedal Sensor(D4FB/D4EA)		
E38	A/C Pressure Transducer		
E39	PTC Heater(D4FB/D4EA)		
E40	TCM(D4FB)		
E41	Glow Plug Relay(D4FB/D4EA)		
E42	PTC Heater Relay #1(D4FB/D4EA)		
E43	PTC Heater Relay #2(D4FB/D4EA)		
E44	PTC Heater Relay #3(D4FB/D4EA)		
E45	Fuel Filter Heater Relay(D4FB/D4EA)		
E46	ESP Control Module		
E47	ABS Control Module		
E50	Air Heater Relay(D4FB)		
E52	Front TPMS Initiator RH		
E53	VGT Actuator(D4EA)		

FRONT & FRONT END MODULE HARNESS (1)

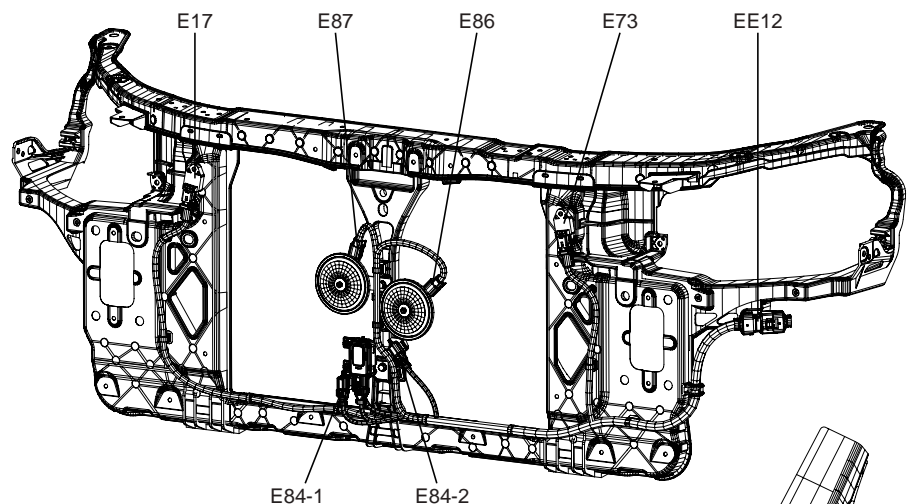

FRONT END MODULE HARNESS

- E17 Front Impact Sensor RH
- E73 Front Impact Sensor LH
- E84-1 Ambient Temperature Sensor #1
- E84-2 Ambient Temperature Sensor #2
- E86 Horn (High)(With Dual Horn)
- E87 Horn (Low)
- EE12 Connection With FRONT Harness

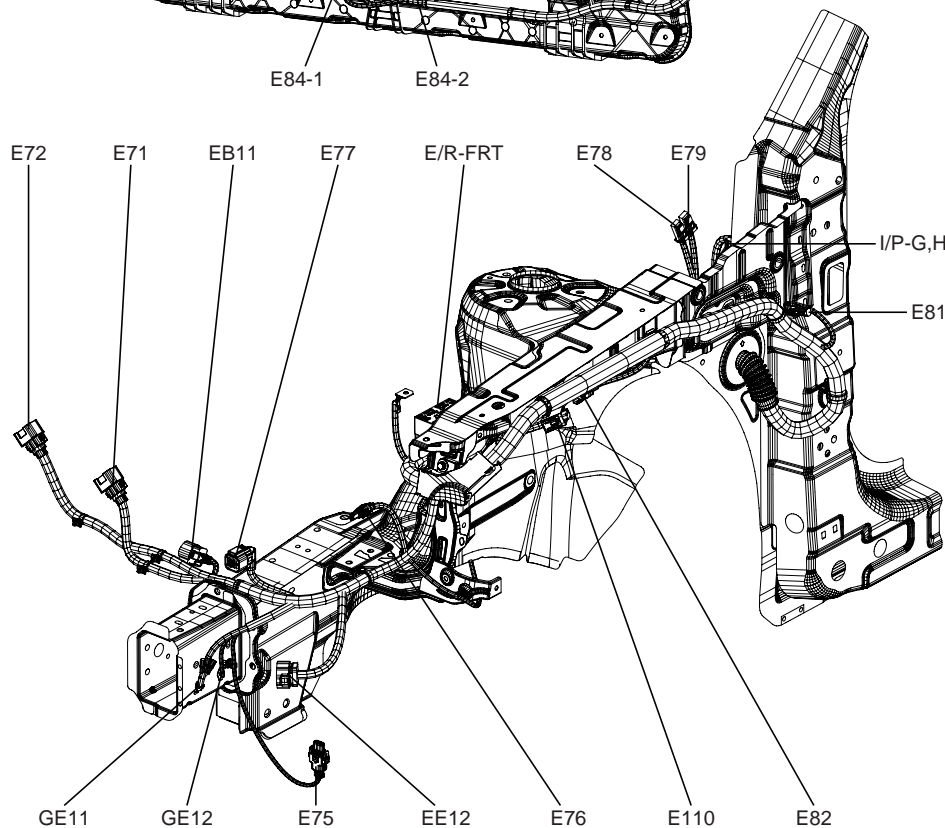

FRONT HARNESS

- E71 Cooling Fan Motor(G4FC/G4GC)
- E72 Cooling Fan Motor(D4FB/D4EA)
- E75 Front Fog Lamp LH
- E76 Head Lamp Leveling Actuator LH
- E77 Head Lamp LH
- E78 EPS Control Module
- E79 EPS Control Module
- E81 Side Repeater Lamp LH
- E82 Front Wheel Sensor LH
- E110 Front TPMS Initiator LH
- EB11 Connection With BATTERY Harness
- EE12 Connection With FRONT END MODULE Harness
- EM31 Connection With MAIN Harness
- E/R-FRT Connection With E/R JUNCTION BOX Harness
- I/P-G Connection With I/P JUNCTION BOX Harness
- I/P-H Connection With I/P JUNCTION BOX Harness
- GE11 Ground
- GE12 Ground
- GE13 Ground

BATTERY HARNESS (1)

G4FC

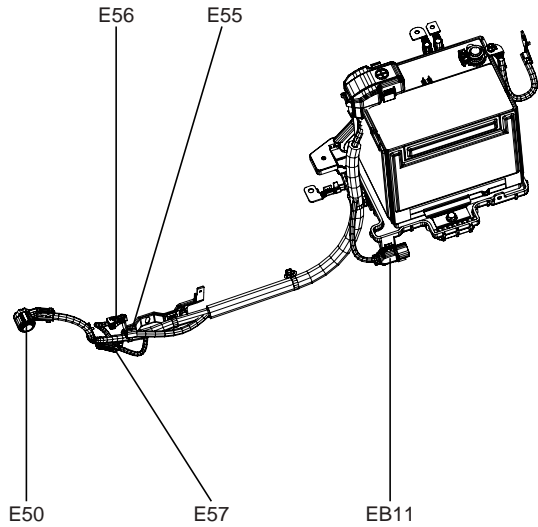

G4GC

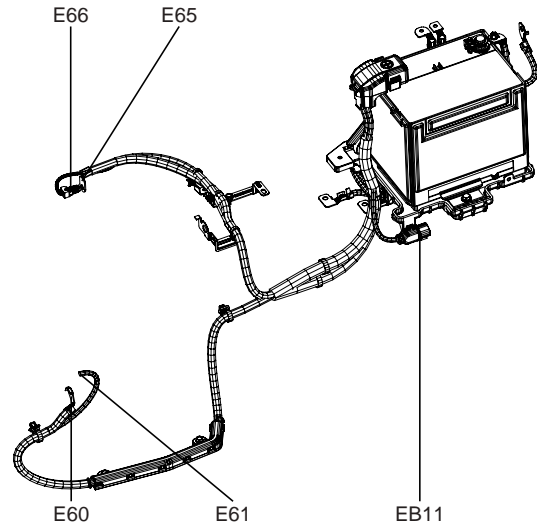

BATTERY HARNESS (G4FC)

- E50 Generator
- E55 Start Motor
- E56 Start Solenoid
- E57 Oil Pressure Switch
- EB11 Connection With FRONT Harness

BATTERY HARNESS (G4GC)

- E60 Generator
- E61 Generator
- E65 Start Motor
- E66 Start Solenoid
- EB11 Connection With FRONT Harness

D4FB

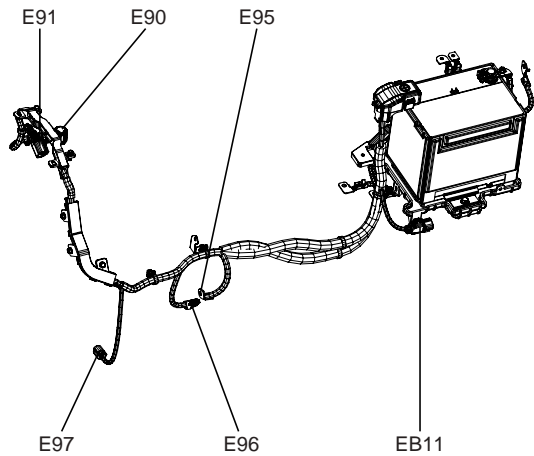

D4EA

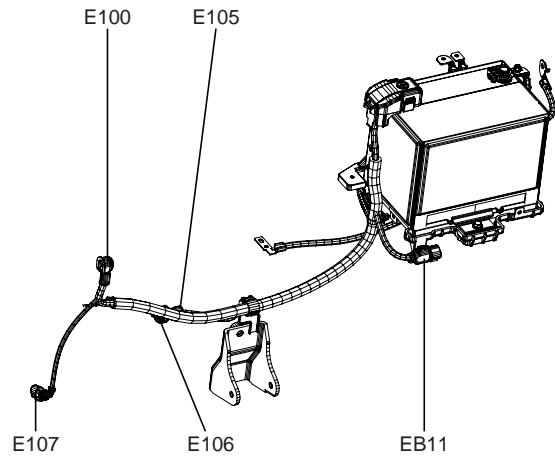

BATTERY HARNESS (D4FB)

- E90 Generator
- E91 Generator
- E95 Start Motor
- E96 Start Solenoid
- E97 A/C Compressor
- EB11 Connection With FRONT Harness

BATTERY HARNESS (D4EA)

- E100 Generator
- E105 Start Motor
- E106 Start Solenoid
- E107 A/C Compressor
- EB11 Connection With FRONT Harness

FLOOR HARNESS (1)

HL-7

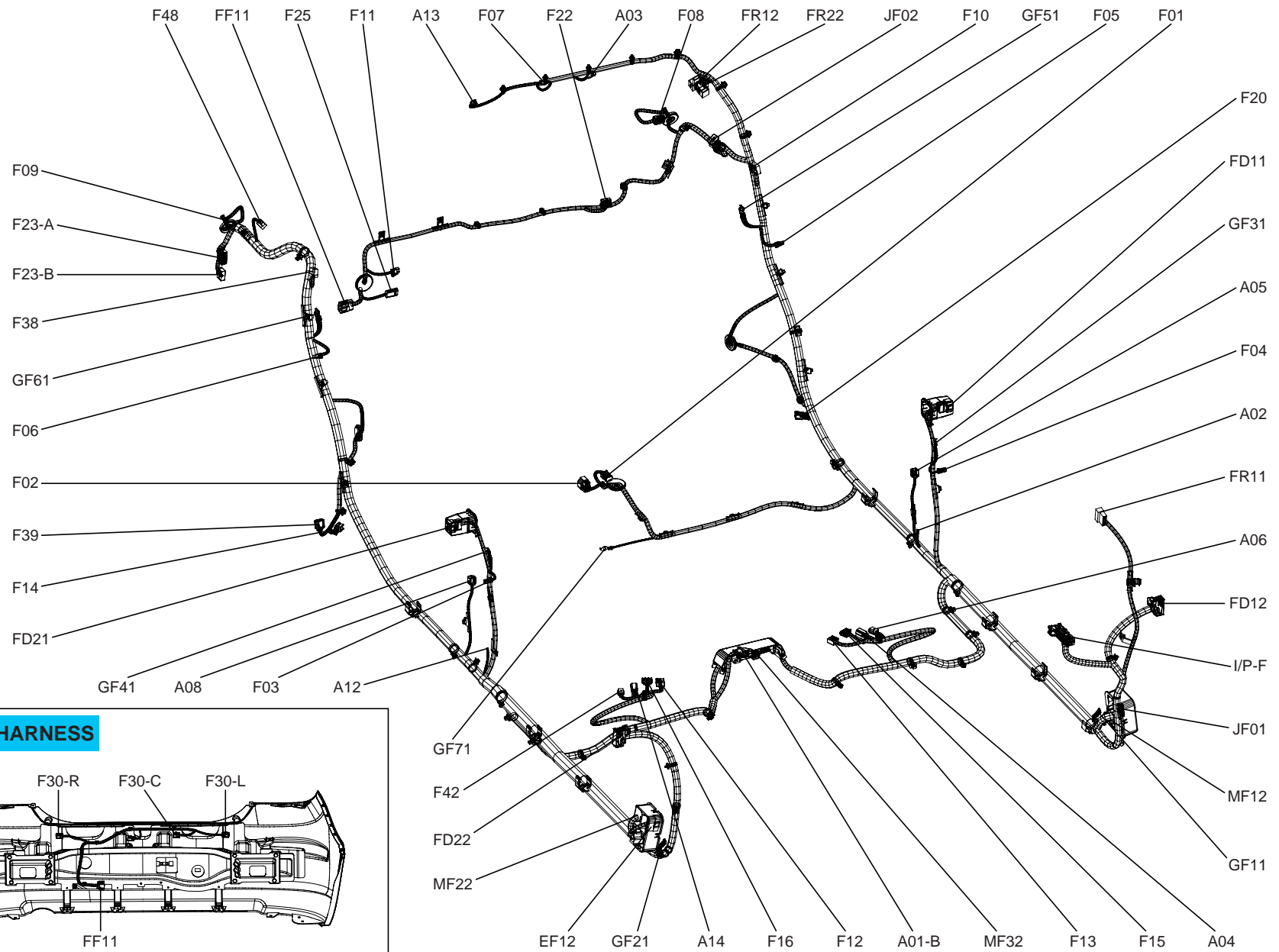

BWS EXT. HARNESS

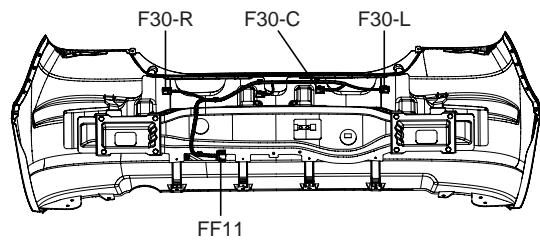

FLOOR HARNESS

FLOOR HARNESS (2)

HL-8

FLOOR HARNESS

F01 Fuel Sender & Fuel Pump Motor
F03 Passenger Door Switch
F04 Driver Door Switch
F05 Rear Door Switch LH
F06 Rear Door Switch RH
F07 Roof Antenna
F08 Rear Combination Lamp LH
F09 Rear Combination Lamp RH
F10 Rear Wiper Control Module
F12 Front Seat Heater Control Module RH
F13 Front Seat Heater Control Module LH
F14 Rear Wheel Sensor RH(With Europe)
F15 Driver Seat Belt Switch
F16 Passenger Seat Belt Switch
F18 Rear Fog Lamp(WGN)
F19 Rear Wheel Sensor RH(W/O Europe)
F20 Rear Wheel Sensor LH
F22 Rear Parking Assist Module
F23-A AMP
F23-B AMP
F25 License Lamp(5DR)
F26 Rear Seat Belt Switch LH
F27 Rear Seat Belt Switch RH
F34 Rear Power Outlet(WGN)
F38 Stop Lamp Failure Module
F39 Rear RH
F42 SBR MAT
F48 Luggage Lamp
JF01 Joint Connector
JF02 Joint Connector
EF12 Connection With ENGINE ROOM Harness
FD11 Connection With DOOR Harness
FD12 Connection With DOOR Harness
FD21 Connection With DOOR Harness
FD22 Connection With DOOR Harness
FF11 Connection With BWS EXT. Harness

FR11 Connection With ROOF Harness
FR12 Connection With TAIL GATE Harness
FR22 Connection With TAIL GATE Harness
I/P-F Connection With I/P JUNCTION BOX Harness
MF12 Connection With MAIN Harness
MF22 Connection With MAIN Harness
GF11 Ground
GF21 Ground
GF31 Ground
GF41 Ground
GF51 Ground
GF61 Ground
GF71 Ground

BWS EXT. HARNESS

F30-C Rear Parking Assist Sensor Center
F30-L Rear Parking Assist Sensor LH
F30-R Rear Parking Assist Sensor RH
FF11 Connection With FLOOR Harness

AIR BAG HARNESS

A01-B SRS Control Module
A02 Driver Seat Belt Pretensioner
A03 Driver Curtain Air Bag(5DR)
A04 Driver Side Air Bag
A05 Driver Side Impact Sensor
A07 Driver Curtain Air Bag(WGN)
A08 Passenger Side Impact Sensor
A09 Passenger Curtain Air Bag(WGN)
A12 Passenger Seat Belt Pretensioner
A13 Passenger Curtain Air Bag(5DR)
A14 Passenger Side Air Bag

CONTROL HARNESS (G4FC) (1)

HL-9

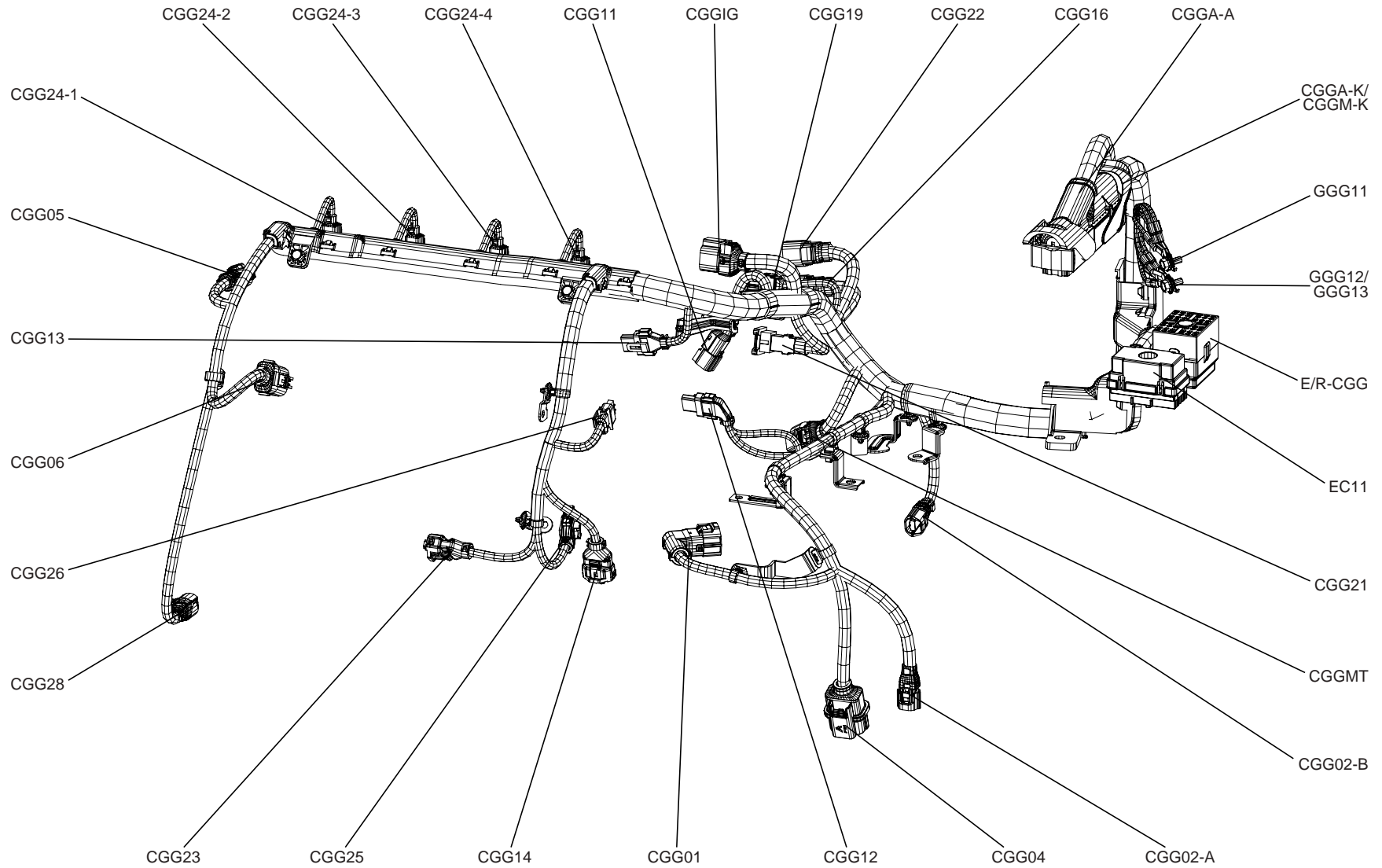

CONTROL HARNESS

CONTROL HARNESS (G4FC) (1)

HL-10

CONTROL HARNESS

CGG01	Transaxle Range Switch
CGG02-A	Pulse Generator 'A'
CGG02-B	Pulse Generator 'B'
CGG04	ATM Solenoid Valve
CGG05	Oil Control Valve
CGG06	Generator
CGG11	Engine Coolant Temperature Sensor & Sender
CGG12	Throttle Position Sensor
CGG13	Camshaft Position Sensor
CGG14	Crankshaft Position Sensor
CGG16	Oxygen Sensor (UP)(EURO ¥2/¥3)
CGG19	Condenser
CGG21	Purge Control Solenoid Valve
CGG22	Oxygen Sensor (DOWN)(EURO ¥2/¥3 ONLY)
CGG23	Knock Sensor
CGG24-1	Injector #1
CGG24-2	Injector #2
CGG24-3	Injector #3
CGG24-4	Injector #4
CGG25	MAP Sensor
CGG26	Idle Speed Control Actuator
CGG28	A/C Compressor
CGGA-A	PCM(A/T)
CGGA-K	PCM(A/T)
CGGM-K	ECM(M/T)
CGGIG	Connection With IGNITION COIL EXT. harness
CGGMT	Connection With MTM EXT. harness
EC11	Connection With ENGINE ROOM harness
E/R-CGG	Connection With E/R JUNCTION BOX harness
GGG11	Ground
GGG12	Ground(A/T)
GGG13	Ground(M/T)

IGNITION COIL EXT. HARNESS

CGG18-1	Ignition Coil #1
CGG18-2	Ignition Coil #2
CGG18-3	Ignition Coil #3
CGG18-4	Ignition Coil #4
CGGIG	Connection With CONTROL harness

MTM EXT. HARNESS

CGG50	Back-up Lamp Switch
CGG52	Vehicle Speed Sensor
CGGMT	Connection With CONTROL harness

CONTROL HARNESS

CONTROL HARNESS (G4GC) (3)

HL-11

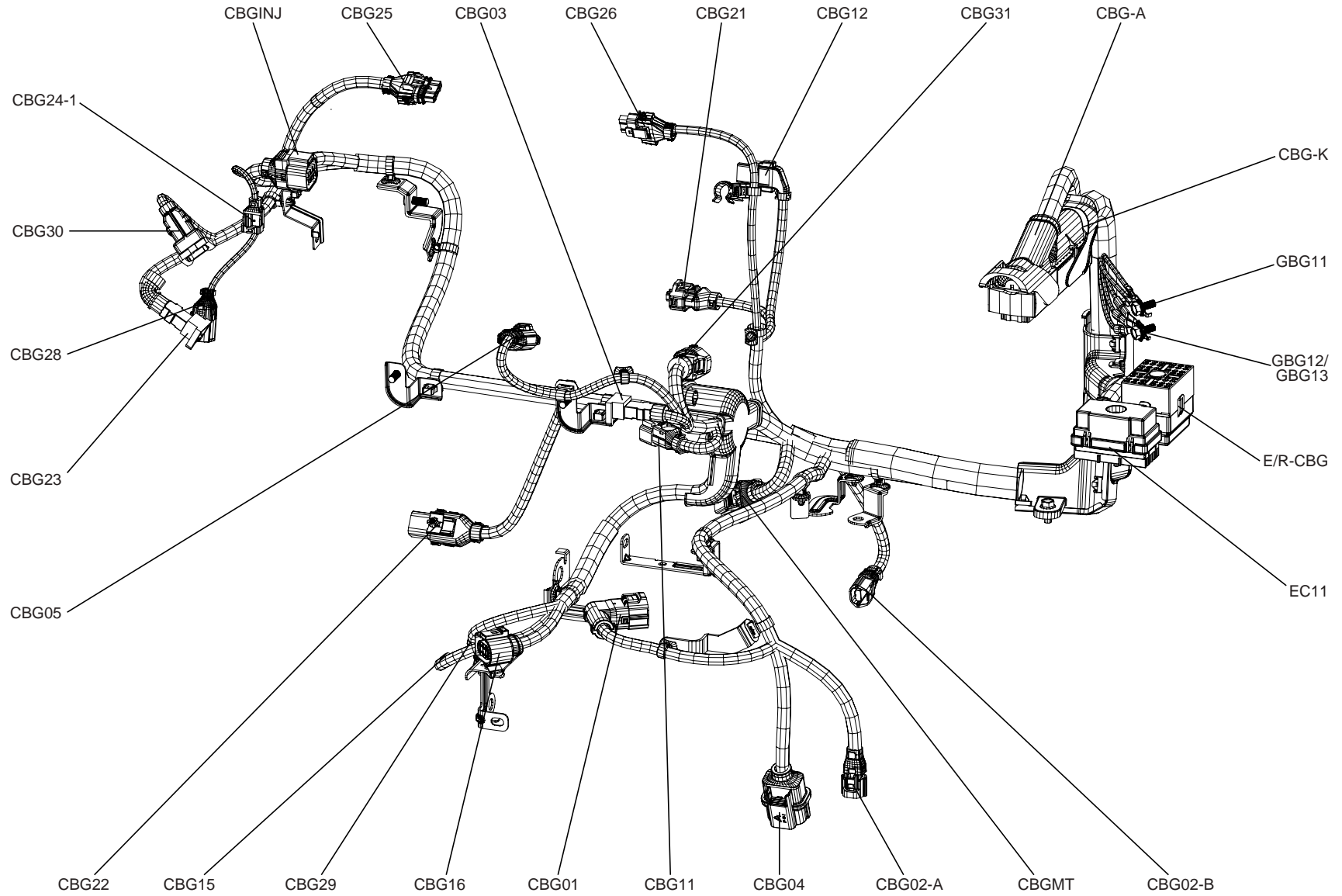

CONTROL HARNESS

CONTROL HARNESS (G4GC) (4)

HL-12

CONTROL HARNESS

CBG01	Transaxle Range Switch
CBG02-A	Pulse Generator 'A'
CBG02-B	Pulse Generator 'B'
CBG03	Oil Temperature Sensor
CBG04	ATM Solenoid Valve
CBG05	Oil Control Valve
CBG11	Engine Coolant Temperature Sensor & Sender
CBG12	Throttle Position Sensor
CBG15	Oil Pressure Switch
CBG16	Oxygen Sensor (UP)(EURO ¥2/¥3)
CBG21	Purge Control Solenoid Valve
CBG22	Oxygen Sensor (DOWN)(EURO ¥2/¥3 ONLY)
CBG23	Knock Sensor
CBG24-1	Injector #1
CBG25	MAP Sensor (EURO ¥2/¥3)
CBG26	Idle Speed Control Actuator
CBG28	A/C Compressor
CBG29	Crankshaft Position Sensor
CBG30	Camshaft Position Sensor
CBG31	Ignition Coil
CBG-A	PCM
CBG-K	PCM
CBGINJ	Connection With INJECTOR EXT. harness
CBGMT	Connection With MTM EXT. harness
EC11	Connection With ENGINE ROOM harness
E/R-CBG	Connection With E/R JUNCTION BOX harness
GBG11	Ground
GBG12	Ground(A/T)
GBG13	Ground(M/T)

IGNITION COIL EXT. HARNESS

CBG24-2	Injector #2
CBG24-3	Injector #3
CBG24-4	Injector #4
CBGINJ	Connection With CONTROL harness

MTM EXT. HARNESS

CBG50	Back-up Lamp Switch
CBG52	Vehicle Speed Sensor
CBGMT	Connection With CONTROL harness

CONTROL HARNESS

CONTROL HARNESS (D4FB) (5)

HL-13

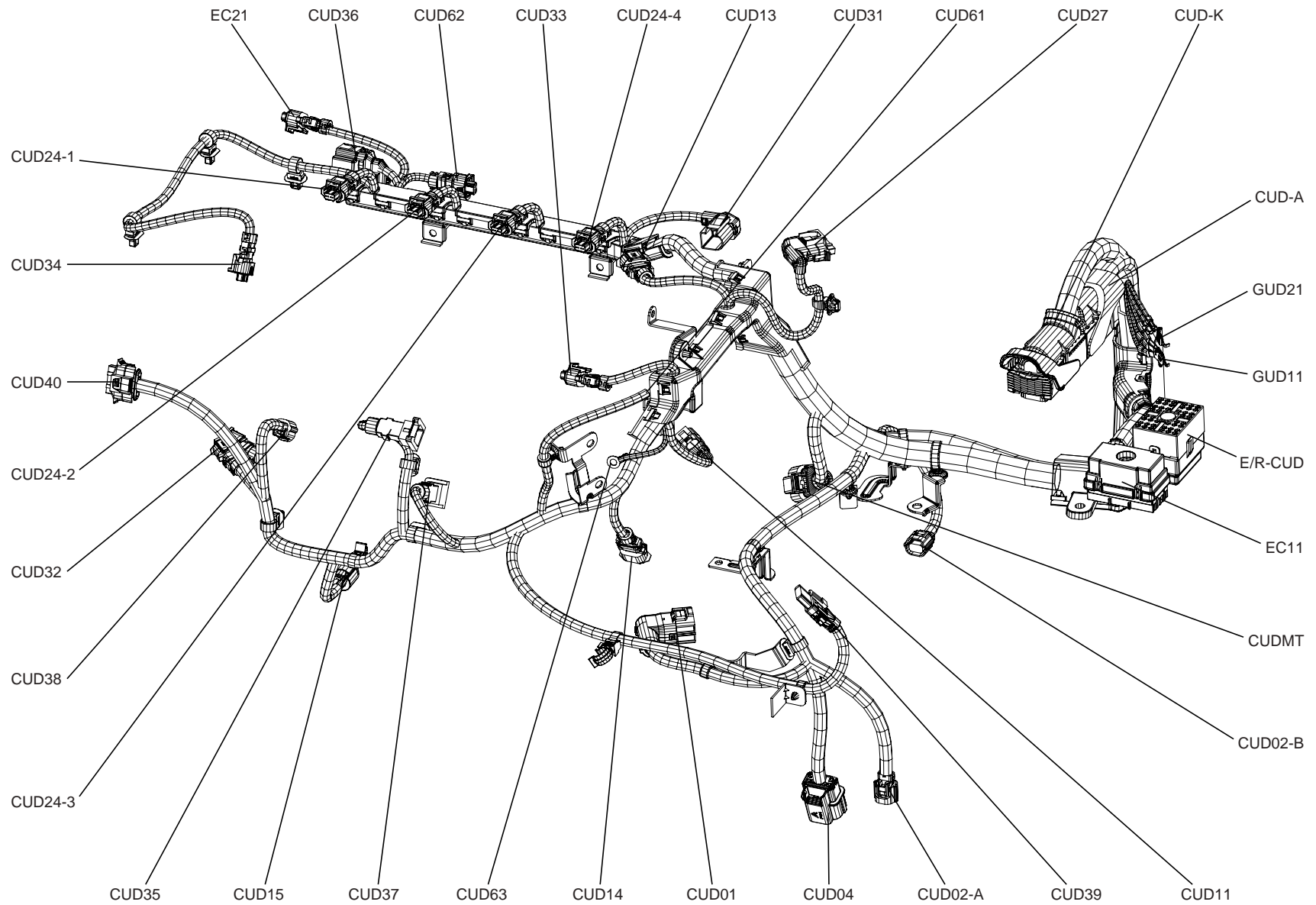

CONTROL HARNESS

CONTROL HARNESS (D4FB) (6)

HL-14

CONTROL HARNESS

CUD01	Transaxle Range Switch
CUD02-A	Pulse Generator 'A'
CUD02-B	Pulse Generator 'B'
CUD04	ATM Solenoid Valve
CUD11	Engine Coolant Temperature Sensor & Sender
CUD13	Camshaft Position Sensor
CUD14	Crankshaft Position Sensor
CUD15	Oil Pressure Switch
CUD24-1	Injector #1
CUD24-2	Injector #2
CUD24-3	Injector #3
CUD24-4	Injector #4
CUD27	Air Flow Sensor
CUD31	EGR Control Actuator
CUD32	Fuel Temperature Sensor
CUD33	Rail Pressure Sensor
CUD34	Rail Pressure Regulator
CUD35	Throttle Flap Actuator(W/O D.P.F)
CUD36	Lambda Sensor
CUD37	VGT Actuator
CUD38	Fuel Pressure Regulating Valve
CUD39	Booster Pressure Sensor
CUD40	Variable Swirl Control Actuator
CUD61	Electrical Throttle Actuator(With D.P.F)
CUD62	Exhaust Gas Temperature #1
CUD63	Air Heater
CUD-A	ECM
CUD-K	ECM
CUDMT	Connection With MTM EXT. harness
EC11	Connection With ENGINE ROOM harness
EC21	Connection With ENGINE ROOM harness
E/R-CUD	Connection With E/R JUNCTION BOX harness
GUD11	Ground
GUD21	Ground

MTM EXT. HARNESS

CUD50	Back-up Lamp Switch
CUD51	Neutral Switch
CUD52	Vehicle Speed Sensor
CUDMT	Connection With CONTROL harness

CONTROL HARNESS

CONTROL HARNESS (D4EA) (7)

HL-15

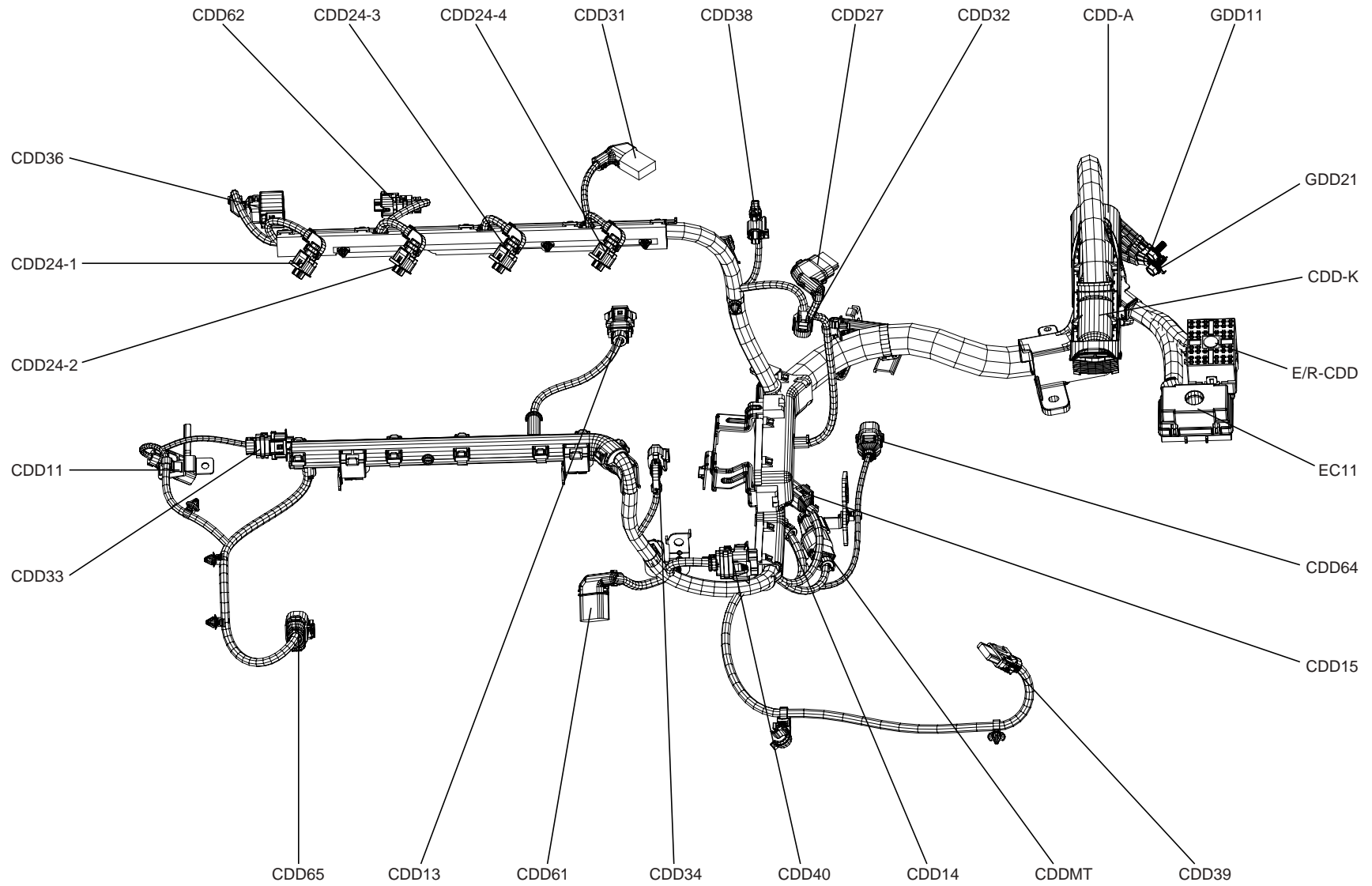

CONTROL HARNESS

CONTROL HARNESS (D4EA) (8)

HL-16

CONTROL HARNESS

CDD11	Engine Coolant Temperature Sensor & Sender
CDD13	Camshaft Position Sensor
CDD14	Crankshaft Position Sensor
CDD15	Oil Pressure Switch
CDD24-1	Injector #1
CDD24-2	Injector #2
CDD24-3	Injector #3
CDD24-4	Injector #4
CDD27	Air Flow Sensor
CDD31	EGR Control Actuator
CDD32	Fuel Temperature Sensor
CDD33	Rail Pressure Sensor
CDD34	Rail Pressure Regulator
CDD36	Lambda Sensor
CDD38	Fuel Pressure Regulating Valve
CDD39	Booster Pressure Sensor
CDD40	Variable Swirl Control Actuator
CDD61	Electrical Throttle Actuator
CDD62	Exhaust Gas Temperature #1
CDD64	Neutral Switch
CDD65	Generator
CDD-A	ECM
CDD-K	ECM
CDDMT	Connection With MTM EXT. harness
EC11	Connection With ENGINE ROOM harness
E/R-CDD	Connection With E/R JUNCTION BOX harness
GDD11	Ground
GDD21	Ground

MTM EXT. HARNESS

CDD50	Back-up Lamp Switch
CDD52	Vehicle Speed Sensor
CDDMT	Connection With CONTROL harness

DOOR HARNESS (1)

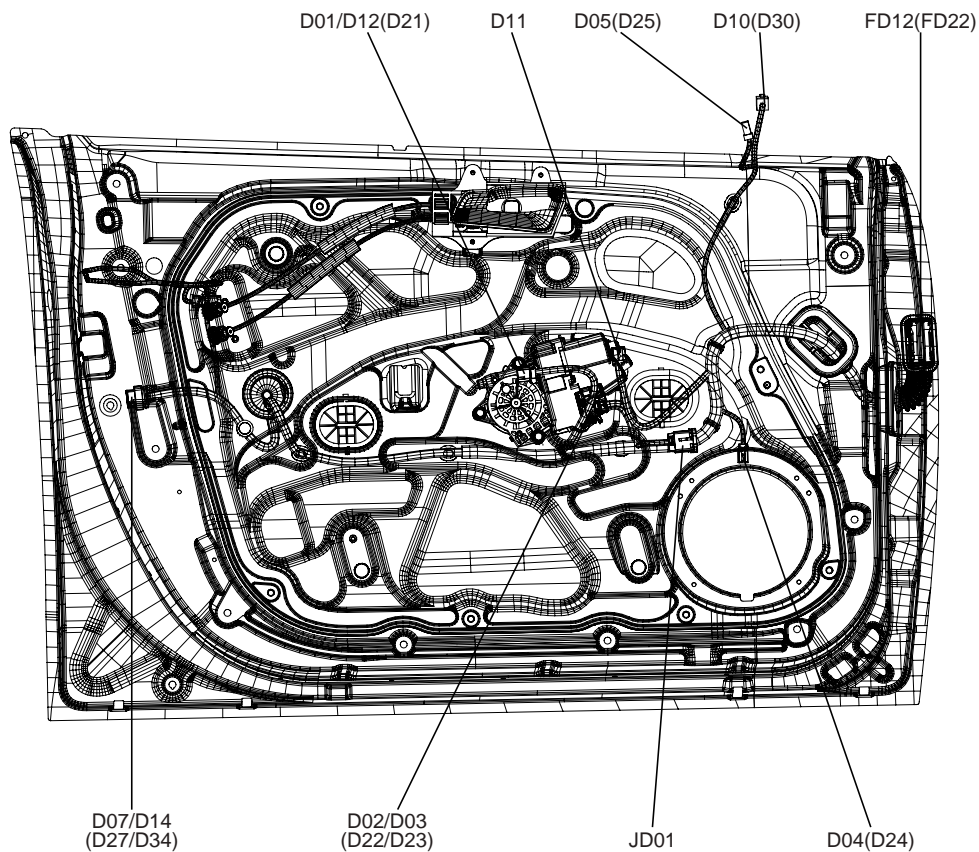

DRIVER DOOR HARNESS

- D01 Power Window Main Switch
- D02 Driver Power Window Motor
- D03 Driver Safety Power Window Module
- D04 Driver Door Speaker
- D05 Driver Tweeter Speaker
- D07 Driver Door Lock Actuator(LHD/W/O Dead Lock)
- D08 Driver Door Lock Actuator(RHD/W/O Dead Lock)
- D10 Driver Power Outside Mirror & Mirror Folding Motor
- D11 Power Outside Mirror & Mirror Folding Switch
- D12 Safety Power Window Main Switch
- D14 Driver Door Lock Actuator (RHD/With Dead Lock)
- JD01 Joint Connector
- FD12 Connection With FLOOR Harness

PASSENGER DOOR HARNESS

- D21 Passenger Power Window Switch
- D22 Passenger Power Window Motor
- D23 Passenger Safety Power Window Module
- D24 Passenger Door Speaker
- D25 Passenger Tweeter Speaker
- D27 Passenger Door Lock Actuator(LHD/W/O Dead Lock)
- D28 Passenger Door Lock Actuator(RHD/W/O Dead Lock)
- D30 Passenger Power Outside Mirror & Mirror Folding Motor
- D34 Passenger Door Lock Actuator(RHD/With Dead Lock)
- FD22 Connection With FLOOR Harness

() : Passenger

DOOR HARNESS

DOOR HARNESS (2)

HL-18

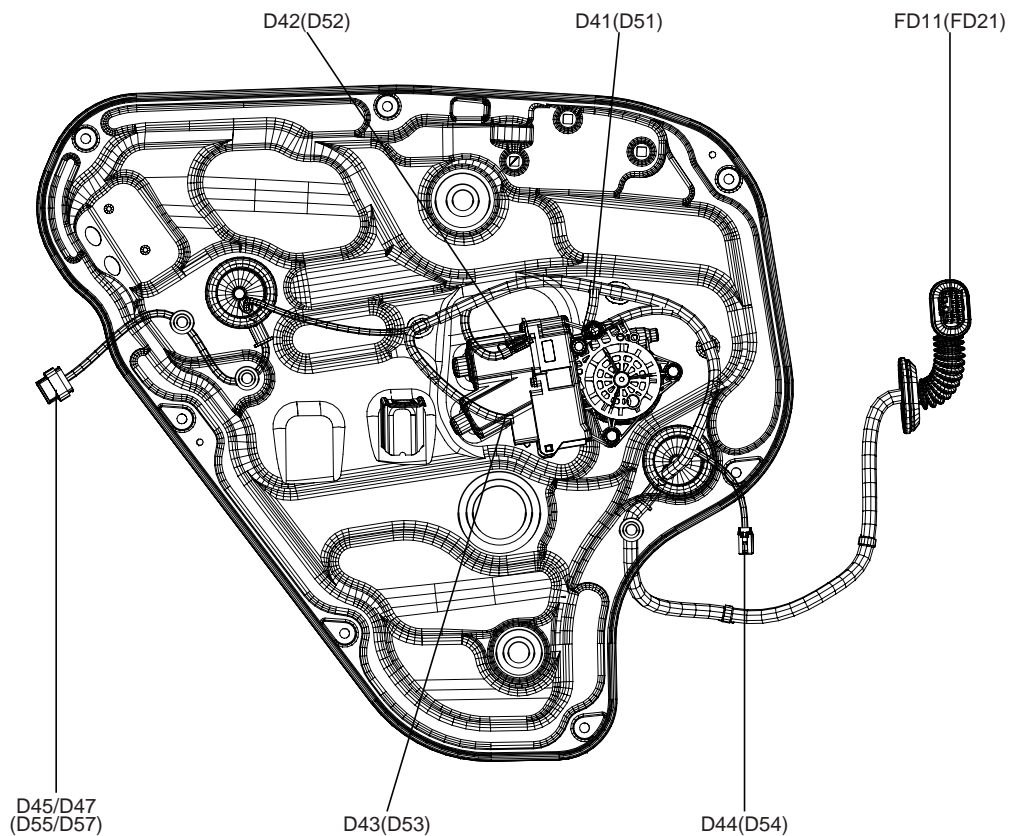

REAR DOOR LH HARNESS

- D41 Rear Power Window Switch LH
- D42 Rear Power Window Motor LH
- D43 Rear Safety Power Window Module LH
- D44 Rear Door Speaker LH
- D47 Rear Door Lock Actuator LH
- FD11 Connection With FLOOR Harness

REAR DOOR RH HARNESS

- D51 Rear Power Window Switch RH
- D52 Rear Power Window Motor RH
- D53 Rear Safety Power Window Module RH
- D54 Rear Door Speaker RH
- D57 Rear Door Lock Actuator RH
- FD21 Connection With FLOOR Harness

(): RH

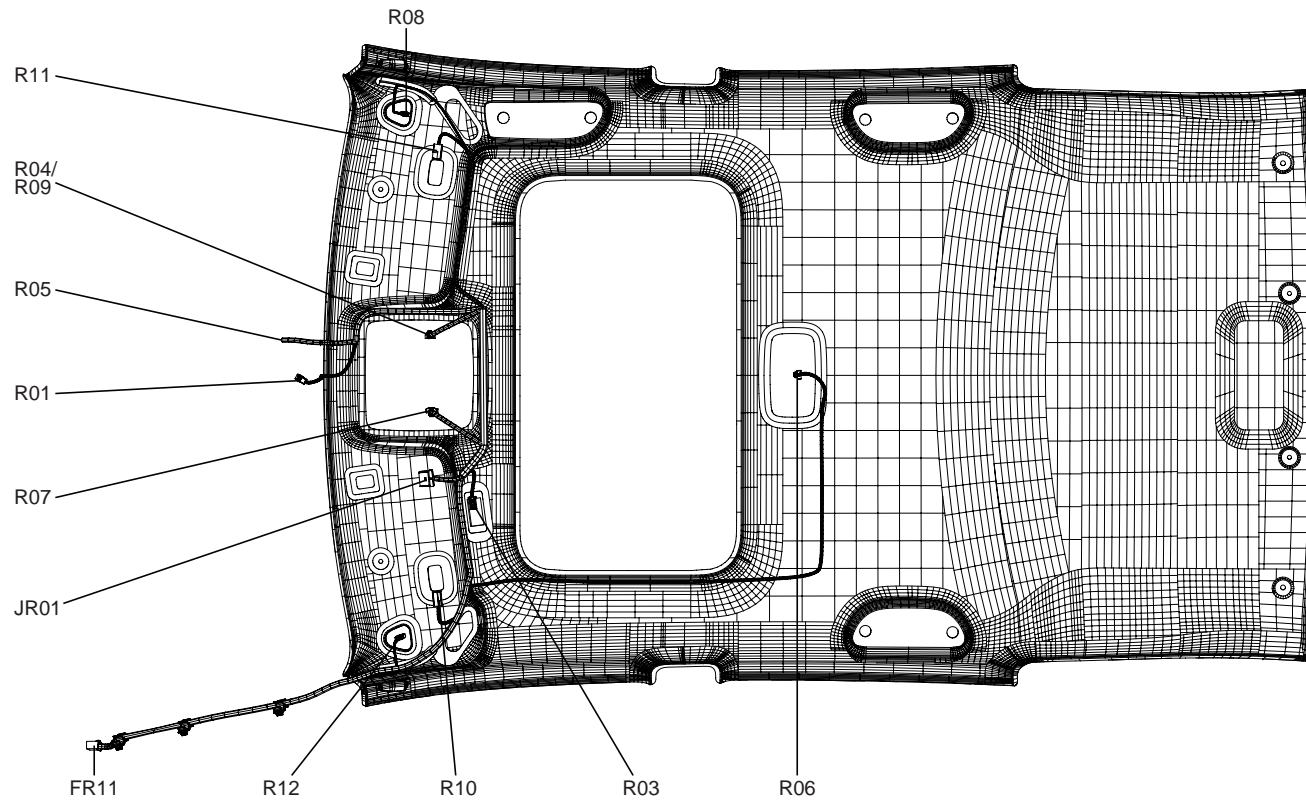

ROOF HARNESS

- R01 Electro Chromic Mirror
- R04 Map Lamp(W/O Sunroof)
- R05 Rain Sensor
- R06 Room Lamp
- R07 Sunroof Control Module
- R08 Vanity Lamp Switch RH
- R09 Sunroof Switch
- R10 Vanity Lamp LH
- R11 Vanity Lamp RH
- R12 Vanity Lamp Switch LH
- JR01 Joint Connector
- FR11 Connection With FLOOR Harness

TAIL GATE HARNESS (1)

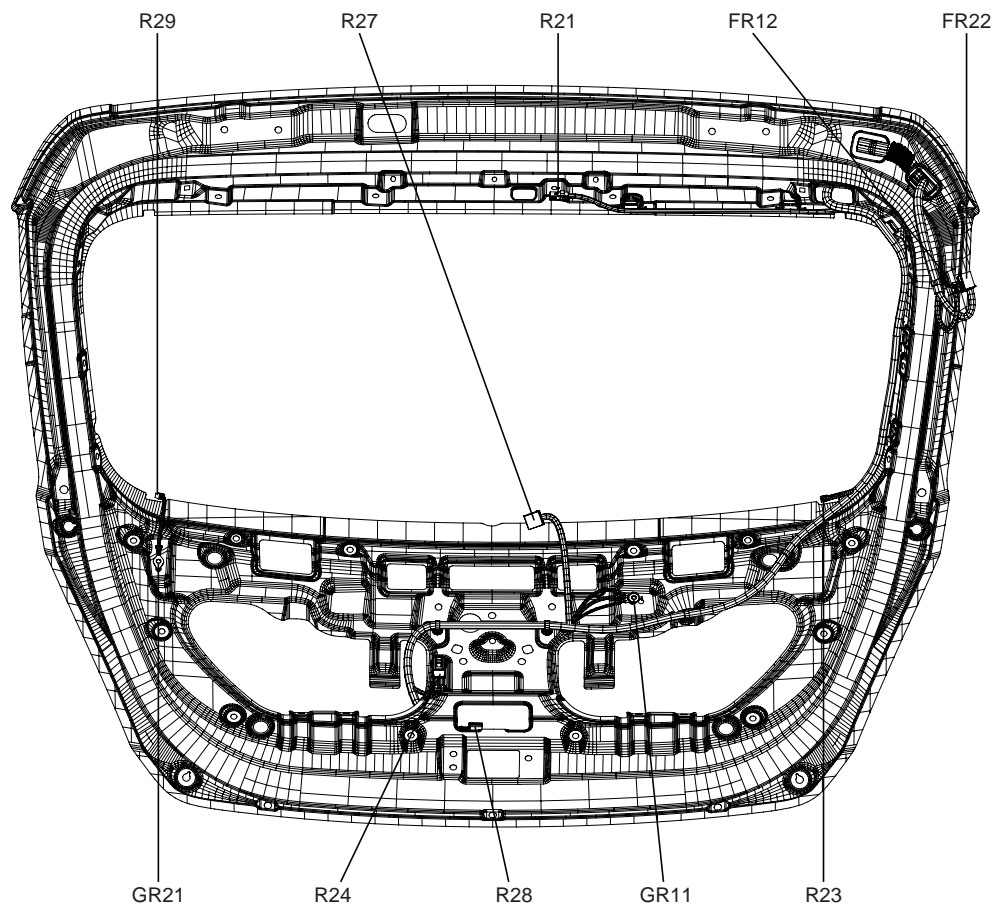

TAIL GATE HARNESS

- R21 High-mounted Stop Lamp
- R22 Roof Antenna
- R23 Rear Defogger (+)
- R24 Tail Gate Switch(5DR)
- R25 Tail Gate Switch(WGN)
- R26 License Lamp(WGN)
- R27 Rear Wiper Motor
- R28 Tail Gate Actuator
- FR12 Connection With FLOOR Harness
- FR22 Connection With FLOOR Harness
- GR11 Ground

REAR HTD (-) HARNESS

- R29 Rear Defogger (-)
- GR21 Ground