



# INTRODUCTION

## Introduction (2)

GI-2

### Starting System

#### Starting System (2)

SD360-2

② Connector configurations (components)

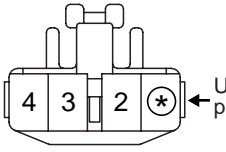
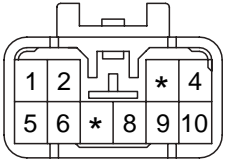
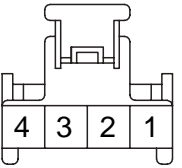
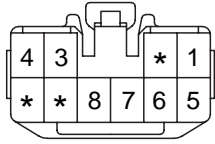
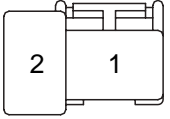
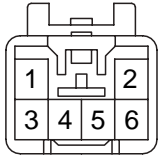
<p><b>M05</b></p>  <p>KET_090II_04F_W</p>	<p><b>M06</b></p>  <p>KET_090II_10M_W</p>	<p><b>M11</b></p>  <p>KUM_AR_04F_W</p>	<p><b>M13</b></p>  <p>KET_090II_10F_W</p>
<p><b>M67</b></p>  <p>AMP_PLM2_02F_B</p>	<p><b>M81</b></p>  <p>KET_090II_06M_W</p>	<p><b>BLANK</b></p>	<p><b>BLANK</b></p>

E2RG360B

Explanation of connector code

### M05

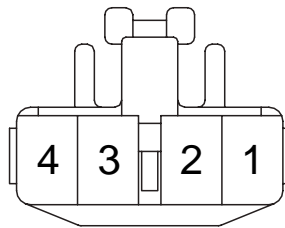

KET\_090II\_04F\_W

a b c d e

a : Connector manufacturer

b : Terminal series number

c : The number of connector terminals

d : Connector distinguishing

- Female Pin : F
- Male Pin : M

e : Connector color abbreviations

- B (Black)
- Br (Brown)
- G (Green)
- Gr (Gray)
- L (Blue)
- R (Red)
- W (White)
- Y (Yellow)

# INTRODUCTION

## Introduction (3)

GI-3

### ① Pages by system/ Name of Schematic diagram

- Each page is consisted of circuits by system. This schematic diagram includes the path of electricity flow, connection condition for each switch, and the function of other relevant circuits at once. It is applicable to real service work.
- It is very important to understand relevant circuits exactly before troubleshooting diagnosis.
- Circuits by system depends upon part number and are indicated on schematic diagram index.

### ② Connector configuration (components)

- The connector figure of components in the schematic diagram by system is indicated on the last page of schematic diagram.
- It shows the front of the connector on the harness side when not to the harness connector. The terminal number on each connector can be obtained by following the pattern used in ⑤ connector view and numbering order. Unused terminals are marked with an asterisk (\*).

### ③ Connector configurations (connection between harnesses)

- When connecting the harness with connector between harnesses, it shows female and male connectors and indicates them on the connector configurations group.

EM02

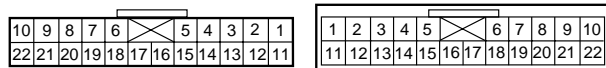

### ④ Component locations

- To find the components easily, a component locations diagram is indicated with "PHOTO NO" on the lower portion of the component name.
- To make it easy to distinguish connectors, the connector in the picture is indicated being installed in the vehicle.

PHOTO 03

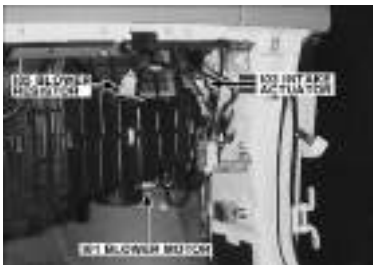

### ⑤ CONNECTOR VIEW AND NUMBERING ORDER

Female	Male	Remarks
		<p>It is not the shape of the connector housing, but the connector pin that distinguishes between male or female connectors. When numbering female and male connectors, refer to the numbering order in the following table. Some connectors may not follow this method of numbering order. For individual detailed numbering, refer to the CONNECTOR CONFIGURATIONS.</p>
		<p>Numbered in order from upper right to lower left</p> <p>Numbered in order from upper left to lower right</p>

### NOTE

UNLESS OTHERWISE STATED, ALL CONNECTOR VIEWS ARE FROM THE TERMINAL SIDE OF THE CONNECTOR.

# INTRODUCTION

## Introduction (4)

GI-4

### ⑥ WIRE COLOR ABBREVIATIONS

The following abbreviations are used to identify wire colors in the circuit schematics.

Symbol	Color of wire	Symbol	Color of wire
B	Black	O	Orange
Br	Brown	P	Pink
G	Green	R	Red
Gr	Gray	W	White
L	Blue	Y	Yellow
Lg	Light Green	Pp	Purple
T	Tan	LI	Light Blue

\* (Y)/(B): Black stripe with yellow ground (2 colors)

↑                      ↑  
the color of      the color of  
background      stripe

### ⑦ HARNESS CLASSIFICATION

Electrical wiring connectors are classified according to the wiring parts in the Harness Layouts.

Symbol	Harness name	Location
A	Air bag harness	Under crash pad and Floor
C	Control, Injector, Ignition, Glow harness	Engine compartment, Passenger compartment
D	Door harness	Door
E	Engine, Battery harness	Engine compartment
F	Floor, Back warning harness	Floor, Tail gate
M	Main harness	Passenger compartment
R	Roof, Tail gate harness	Roof, Tail gate
S	Seat harness	Front seat

\* It depends on vehicles, it is necessary to check the harness name symbol on the harness layouts for detailed symbol.

### ⑧ CONNECTOR IDENTIFICATION

A connector identification symbol consists of a wiring harness location classification symbol corresponding to a wiring harness location and number corresponding to the connector. These connector locations can be found in the HARNESS LAYOUTS.

For example:

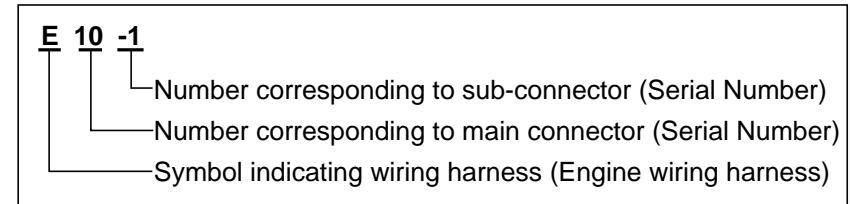

#### NOTE

Connectors which connect each wiring harness are represented by the following symbols.

For example:

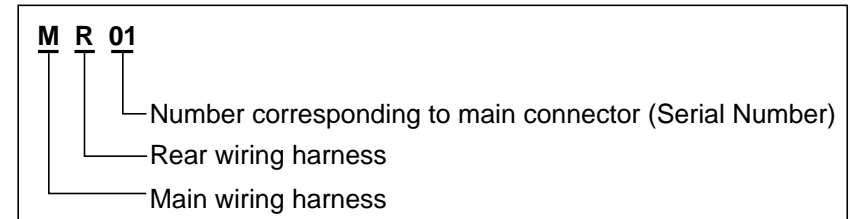

### JUNCTION BLOCK IDENTIFICATION

A junction block identification symbol consists of a wiring harness location classification symbol corresponding to a wiring harness location and number corresponding to the connector in the junction block.

For example:

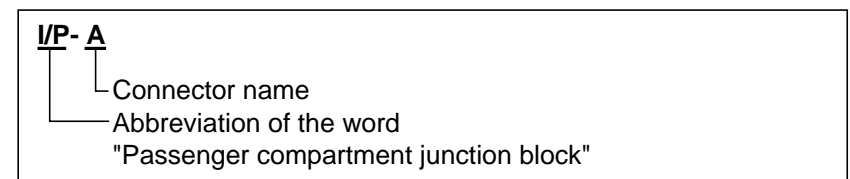



**HARNESS LAYOUTS**

Harness layouts show the routing of the major wiring harnesses, the in-line connectors and the splices between the major harnesses. These layouts will make electrical troubleshooting easier.

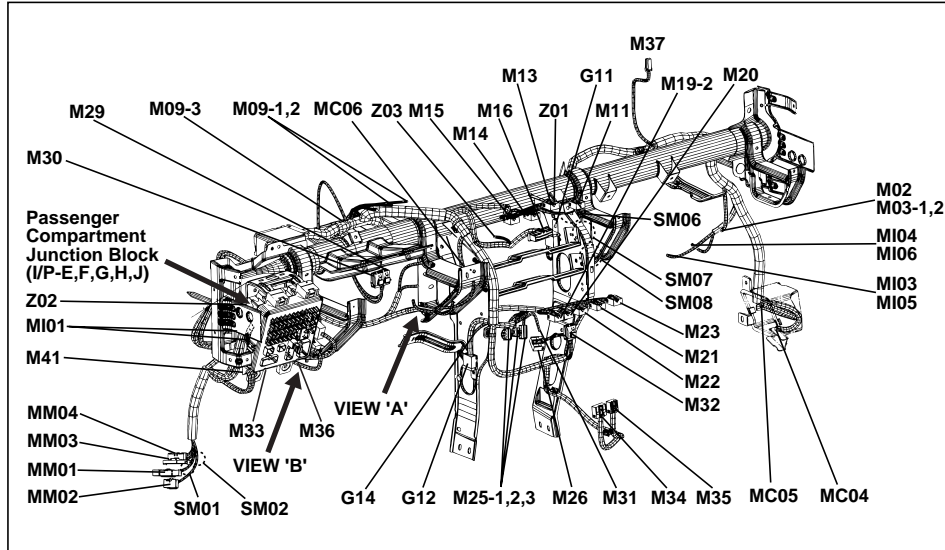









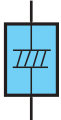

Symbols (1)

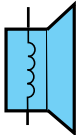
Section	Symbol	Meaning	Section	Symbol	Meaning	Section	Symbol	Meaning	Section	Symbol	Meaning
C O M P O N E N T		A solid line means the entire component is shown.	C O N N E C T O R		Shows the name of each connector on the component location index for reference.	S H I E L D W I R E		This represents RFI (Radio Frequency Interference) Shielding around a wire. The shielding is always connected to ground.	L A M P		Double filament
		A broken line indicates only part of the component is shown.			Indicates the number of corresponding terminal. (Only relevant terminal on the corresponding schematic diagram).			Single filament			
		This means the connector connects directly to the component.	W I R E		A wavy line means the wire is broken but is to be continued.	J O I N T C O N N E C T O R		This is a connector showing the joining wires.	D I O D E		Diode
		This indicates the connector connects to a lead (pigtail), wired directly to the component.			Wire insulation is yellow with a red strip.			Led diode			
		This indicates a screw terminal on the component.	S P L I C E S		Current path is continued on the same page or another page. The arrow shows the direction of current flow. You should look for the "A" in the marked position.	S L O W B L O W		Power supplied at all times. Name Capacity	T R		NPN
		This ground symbol (dot and 3 lines overlapping the component) means the housing of the component is attached to a metal part of the vehicle.			A wire connects to another circuit. The wire is shown again on that circuit which the arrow is pointing.			PNP			
		The name of the component appears next to its upper right corner.	G R O U N D		Name of Circuit	F U S E		This means power is supplied with the ignition on position. This means the short bar connects to other fuses. Identification Current rating	G E N E R A L C O M P O N E N T S Y M B O L		These switches move together: a dashed line shows a mechanical connection between them.
		Shows the number of pictures for component location.			Splices are numbered and shown as a dot with circle. The exact location and connection of these splices may vary among vehicles.			Control battery power at all times			Heater

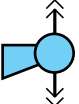
# SYMBOLS

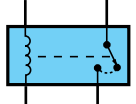
## Symbols (2)

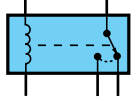
GI-7

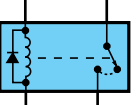
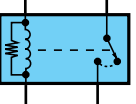
Section	Symbol	Meaning	Section	Symbol	Meaning
GENERAL COMPONENTS SYMBOL		Sensor	GENERAL COMPONENTS SYMBOL		Condenser
		Sender			Speaker
		Injector			Horn, Buzzer, Siren, Chime Bell
		Solenoid	RELAY		Normally open contact
		Motor			This is a relay shown with no current flowing through its coil. When a current flows through coil, contact will toggle.
		Battery			Diode interior relay
				Resistance interior relay	

## Troubleshooting Instructions (1)

GI-8

## TROUBLESHOOTING INSTRUCTIONS

## TROUBLESHOOTING PROCEDURES

The following five-step troubleshooting procedure is recommended.

**1. Verify the customer's complaints**

Turn on all the components in the problem circuit to check the accuracy of the customer's complaints. Note the symptoms. Do not begin disassembly or testing until you have narrowed down the probable causes.

**2. Read and analyze the schematic diagram**

Locate the schematic for the problem circuit. Determine how the circuit is supposed to work by tracing the current paths from the power source through the system components to ground. If you do not understand how the circuit should work, read the circuit operation text. Also check other circuits that share with the problem circuit. The name of circuits that share the same fuse, ground, or switch, for example, are referred to on each diagram. Try to operate any shared circuits you did not check in step 1. If the shared circuit works, the shared wiring is okay, and the cause must be within the wiring used only by the problem circuit.

If several circuits fail at the same time, the fuse or ground is a likely cause.

**3. Inspect the circuit/ component with the problem isolated**

Make a circuit test to check the diagnosis you made in step 2. Remember that a logical, simple procedure is the key to efficient troubleshooting. Narrow down the probable causes using the troubleshooting hints and system diagnosis charts. Test for the most likely cause of failure first. Try to make tests at points that are easily accessible.

**4. Repair the problem**

Once the problem is found, make the necessary repairs.

**5. Make sure the circuit works**

Repeat the system check to be sure you have repaired the problem. If the problem was a blown fuse, be sure to test all of the circuits on that fuse.

## TROUBLESHOOTING EQUIPMENT

**VOLTMETER AND TEST LAMP**

Use a test lamp or a voltmeter on circuits without solidstate units and use a test lamp to check for voltage. A test lamp is made up of a 12-volt light bulb with a pair of leads attached. After grounding one lead, touch the other lead to various points along the circuit where voltage should be present. When the bulb goes on, there is voltage at the point being tested.

**CAUTION**

**A number of circuits include solid-state modules, such as the Engine Control Module(ECM), used with computer command control injection. Voltage in these circuits should be tested only with a 10-megaohm or higher impedance digital multimeter. Never use a test lamp on circuits that contain solid state modules. Damage to the modules may result.**

A voltmeter can be used in place of a test lamp. While a test lamp shows whether the voltage is present or not, a voltmeter indicates how much voltage is present.

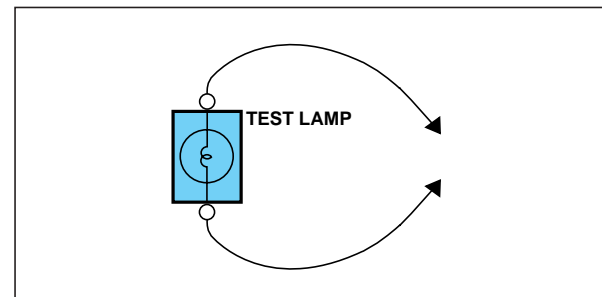
**SELF-POWERED TEST LAMP AND OHMMETER**

Use a self-powered test lamp or an ohmmeter to check for continuity. The ohmmeter shows how much resistance there is between two points along a circuit. Low resistance means good continuity.

## TROUBLESHOOTING INSTRUCTIONS

### Troubleshooting Instructions (2)

GI-9

#### CAUTION

**Never use a self-powered test lamp on circuits that contain solid state modules. Damage to these modules may result.**

An ohmmeter can be used in place of a self-powered test lamp. The ohmmeter shows how much resistance there is between two points along a circuit. Low resistance means good continuity.

Circuits which include any solid-state devices should be tested only with a 10-megaohm or higher impedance digital multimeter. When measuring resistance with a digital multimeter, the battery negative terminal should be disconnected. Otherwise, there may be incorrect readings. Diodes and solid-state devices in a circuit can make an ohmmeter give a false reading. To find out if a component is affecting a measurement, take one reading, reverse the leads and take a second reading. If different the solid-state device is affecting the measurement.

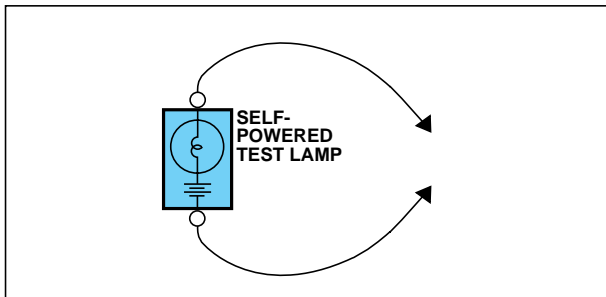

#### JUMPER WIRE WITH FUSE

Use a jumper wire with a fuse to by-pass an open circuit.

A jumper wire is made up of an in-line fuse holder connected to a set of test leads. This tool is available with small clamp connectors providing adaption to most connectors without damage.

#### CAUTION

**Do not use a fuse with a higher rating than the specified fuse that protects the circuit being tested. Do not use this tool in any situation to substitute an input or output at the solid-state control module, such as ECM, TCM, etc.**

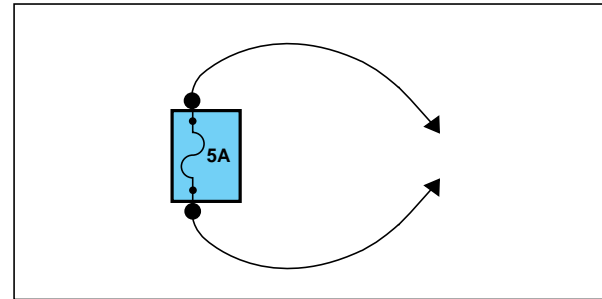

#### SHORT FINDER

A short finder is available to locate a short to ground. The short finder creates a pulsing magnetic field in the shorted circuit and shows you the location of the short through body trim or sheet metal.

#### TROUBLESHOOTING TEST

##### 1. TESTING FOR VOLTAGE

This test measures voltage in a circuit. When testing for voltage at a connector, you do not have to separate the two halves of the connector. Instead, probe the connector from the back(backprobe). Always check both sides of the connector because dirt and corrosion between its contact surfaces can cause electrical problems.

- A. Connect one lead of a test lamp or voltmeter to a ground. If you are using a voltmeter, be sure it is the voltmeter's negative test lead you have connected to ground.
- B. Connect the other lead of the test lamp or voltmeter to a selected test point(connector or terminal).
- C. If the test lamp glows, there is voltage present. If you are using a voltmeter, note the voltage reading. A loss of more than 1 volt from specification indicates a problem.

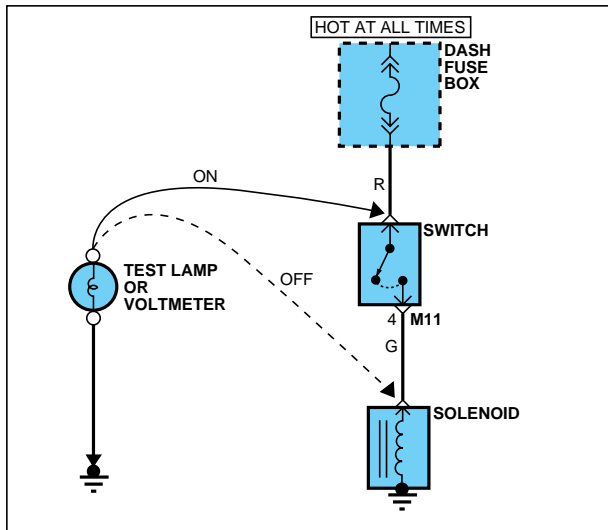

2. TESTING FOR CONTINUITY

- A. Disconnect the battery negative terminal.
- B. Connect one lead of a self-powered test lamp or ohmmeter to one end of the part of the circuit you wish to test. If you are using an ohmmeter, hold the leads together and adjust the ohmmeter to read zero ohms.
- C. Connect the other lead to the other end.
- D. If the self-power test lamp glows, there is continuity. If you are using an ohmmeter, low or zero resistance means good continuity.

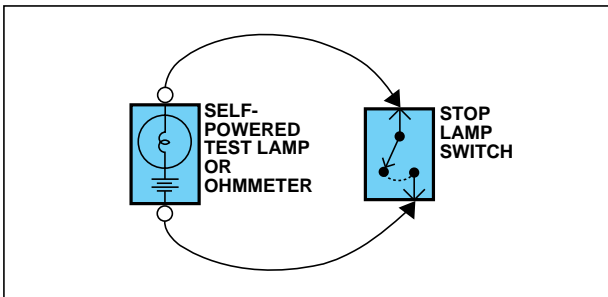

3. TESTING FOR SHORT TO GROUND

- A. Disconnect the battery negative terminal.
- B. Connect one lead of a self-powered test lamp or an ohmmeter to the fuse terminal on the load side.
- C. Connect the other lead to a ground.
- D. Beginning near the fuse block move the harness from side to side. Continue this procedure (about six inches apart) while watching the self-powered test lamp or ohmmeter.
- E. When the self-powered test lamp glows, or ohmmeter registers, there is a short to a ground in the wiring near that point.

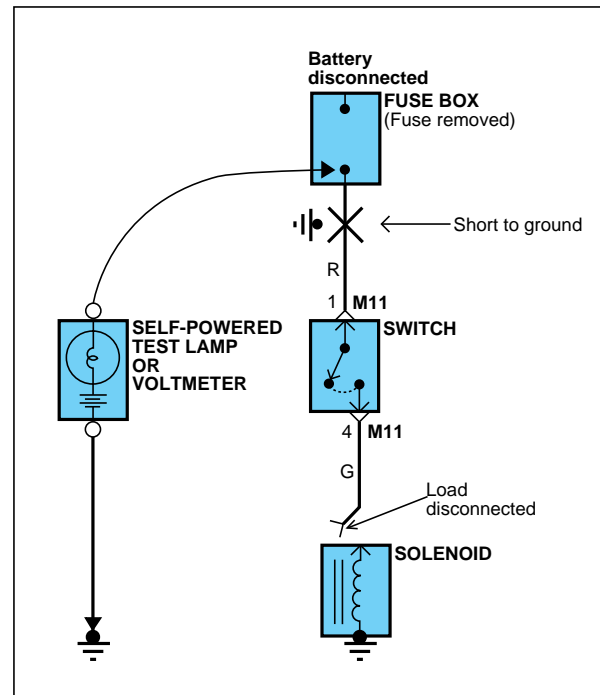

**4. TESTING FOR A SHORT WITH A SHORT FINDER**

- A. Remove the blown fuse. Leave the battery connected.
- B. Connect the short finder across the fuse terminals.
- C. Close all switches in series in the circuit that is being testing.
- D. Turn on the short circuit locator. It sends pulses of current to the short.  
This creates a pulsing magnetic field around the wiring between the fuse box and the short.
- E. Beginning at the fuse box, slowly move the short finder along the circuit wiring. The meter will show current pulses through sheet metal and body trim. As long as the meter is between the fuse and the short, the needle will move with each current pulse. Once the meter is moved past the point of the short, the needle will stop moving. Check around this area to locate the cause of the short circuit.

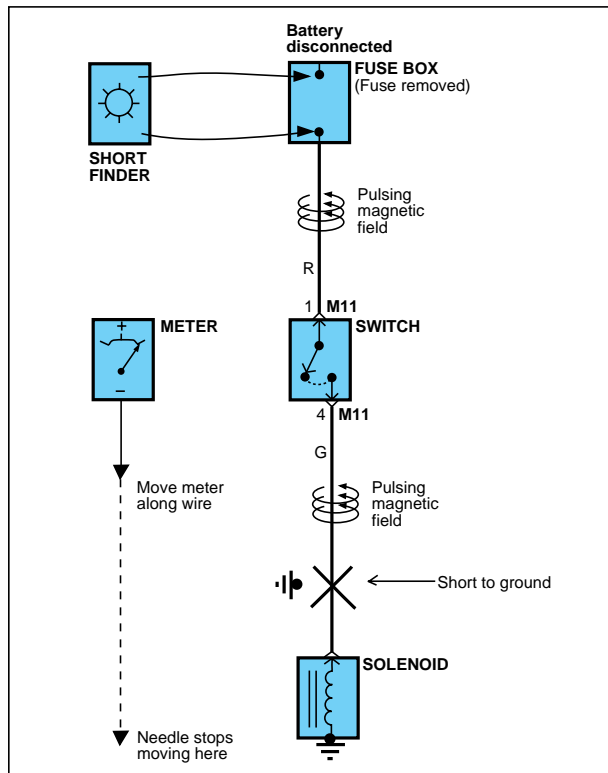

**\* REFERENCE SERVICE TOOLS**

Tool Number	Tool Name
TRK00A	Wiring Repair Kit (Standard Kit)
TRK001	Wire Stripper Set
TRK002	Remover Tool Set
TRK003	Terminal Tension Gauge Set
TRK004	Cable Tie Set
TRK005	Shrink Tube Set
TRK006	Jump Connector Kit(A)
TRK007~10	General Connector Kit(B~E)
TRK011	Terminal With Lead Wire Kit(F)
TRK012	Composition Kit(G)
TRK013	Lead Wire Set
TRK014	Carrying Case
TRK015	User's Guide & Parts Information
TRK016	Inner Box(Large)
TRK017	Inner Box(Small)
TRK018	Solder

\* For more details, refer to the User's guide & parts Information of the Wiring Repair Kit (Pub. No. : OSG200208).

**\* Wiring Repair Kit**

[Standard Kit (TRK00A)]

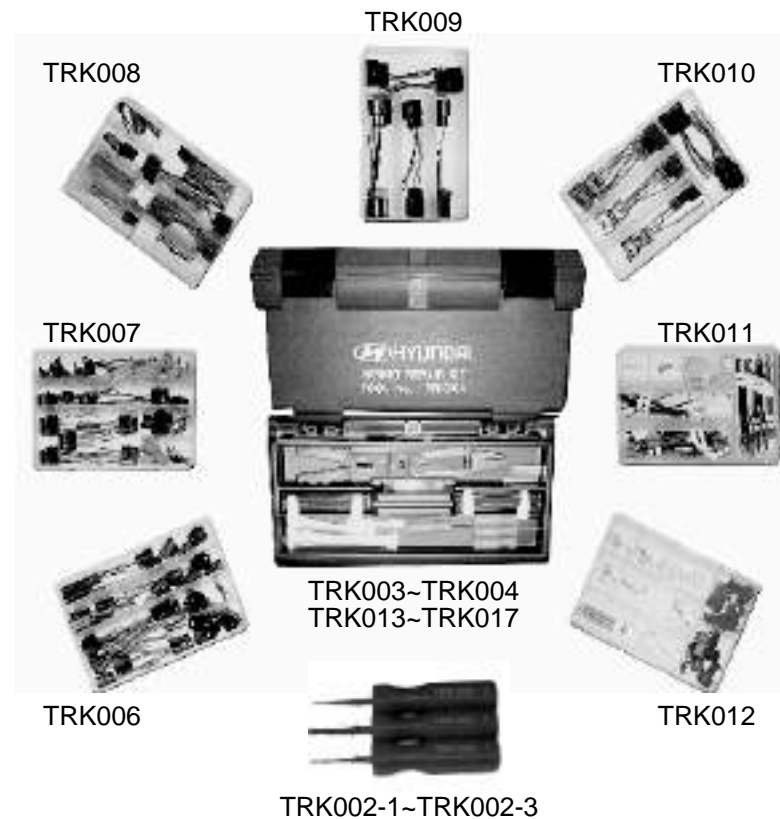

**\* Optional Items**





**REWORK PROCEDURE**

**1. Use of Wire stripper set (TRK001)**

- 1) Disconnect the battery cable.
  - 2) Choose the correct clamping slot for the wire and strip off the wire coat.
- ⦿ If the incorrect crimping slot is used, the terminal may be damaged and may not fit into the connector.



**2. Use of Remover tool set (TRK002)**

▶ **Flat tip type** : Removal of single locking male/female terminal from the connector.

- 1) Remove the front or rear retainer (holder, stopper) of the connector.



- 2) Ensure that the tip of the tool is inserted into the gap between the elastic arm of key and terminal.



- 3) Remove the terminal and check the terminal condition, if there is a damaged, replace it with a new terminal.

▶ **Double tip type** : Removal of double locking male/female terminal from the connector.



**3. Use of Terminal tension gauge set (TRK003)**

- 1) Select the tension gauge that matches the female terminal to be checked.



- 2) Insert a tension gauge into the female terminal and check the terminal condition. (as shown in the photograph)



⦿ If the tension of female terminal is not tight enough, remove it and replace the terminal and wire assembly (including seal).



**4. Use of Ring terminal (TRK012-4)**

- 1) Strip off about 5mm of the wire coat at the end of the wire.



- 2) Joint the stripped wire with ring terminal and crimp using wire stripper.



- 3) Put the shrink tube over the connection area and shrink the tube using electrical hot gun.

**5. Use of Inline solder (TRK012-5) and Shrink tube set (TRK005)**

- 1) Strip off about 5mm of the wire coat at the end of the wires.



- 2) Insert each wire into the opposite ends of the inline solder and crimp using wire stripper.



- 3) Put the shrink tube over the connection area and shrink the tube using electrical hot gun.



- ◎ Shrink tube should be securely wrapped around the inline solder area.



**6. Use of Terminal with lead wire kit (TRK011)**

- 1) Remove the damaged connector and terminal using remover tool.



- 2) Select the right wire, which is fitted with the terminal specification from terminal with lead wire box and cut of the end of wire using wire stripper.



- 3) Put the end of each cut off wire in the middle of the splice joint terminal and compress using wire stripper.



- 4) Put the shrink tube over the connection area and shrink the tube using electrical hot gun.



- 5) Insert the terminal with lead wire into the connector.







# FUSE & RELAY INFORMATION

## Fuse & Relay Information (2)

SD100-2

### CIRCUIT

FUSE	(A)	Circuit Protected
AUDIO 2	10A	Navigation module, Smart key control module Camera control module, Power outlet relay, Audio MTS module, Digital clock, BCM, A/V head module Tuner module
C/LIGHTER	20A	Cigarette lighter & Power outlet
A/BAG 2	10A	Telltale lamp
A/BAG 1	15A	SRS control module
A/BAG IND	10A	Instrument cluster(Air bag IND.)
B/UP LP	10A	Back-up lamp relay, TCM, Electro chromic mirror Back warning control module, IMS control module Rear combination lamp LH/RH, Navigation module MTS module, Rear parking assist control module Camera control module
CRUISE	10A	Multifunction switch(Cruise remocon switch) Smart key control module Driver/Passenger seat warmer switch
ATM CONT	10A	4WD ECM, BCM, Multifunction switch(Light) Semi active engine mounting control module
CLUSTER	10A	Instrument cluster(Micom, IND.), Generator BCM, MTS module, Smart key control module Semi active engine mounting control module Tire pressure monitoring module
START	10A	Burglar alarm relay, Power tail gate control module
EPS	10A	Power window main switch, Camera control module Front power window switch RH, BCM, Rheostat
A/Con	10A	Front/Rear A/Con control module, Blower relay Rear A/Con relay, Electro chromic mirror Sunroof control module, A/V head module, Rain sensor Auto A/Con keyboard, Fuel filter heater relay(DSL) Auto head lamp leveling device sensor
FR S/HTR	15A	Driver/Passenger Seat warmer switch
RR S/HTR	15A	Rear seat warmer switch LH/RH, Rear seat warmer relay
IMS	10A	IMS control module, Tilt & Telescopic module PTC heater relay, Power tail gate control module
H/LP AQS	10A	Head lamp(low) relay LH/RH, Head lamp(high) relay Head lamp leveling device actuator LH/RH, AQS sensor
FR WIPER	15A	Front wiper relay, Front washer relay
RR WIPER	15A	Rear wiper control module, Rear wiper motor Multifunction switch(Wiper)

FUSE	(A)	Circuit Protected
TAIL LH	10A	Head lamp LH, Rear combination lamp LH Tail gate handle switch & license lamp Rear camera, Front fog lamp relay
TAIL RH	10A	Head lamp RH, Rear combination lamp RH, DRL relay Glove box lamp, Illuminations, Trailer lamp connector
DR LOCK	20A	Power window main switch, Power tail gate relay Tail gate lock actuator relay
STOP LP	15A	Stop lamp switch
ADJ-PEDAL	15A	-
H/LP WASHER	20A	Head lamp washer relay
FUEL LID	15A	Fuel lid switch
RR FOG	15A	Rear fog lamp relay
FR WIPER	30A	Front wiper motor
TILT & TELE	15A	Tilt & Telescopic module
DRL	15A	-
P/WDW LH	25A	Driver safety window ECM, Rear power window switch LH
P/WDW RH	25A	Front/Rear power window switch RH
MIRR HTD	10A	Power outside mirror motor & Defogger LH/RH A/V head module Front A/Con control module(Defogger switch)
P/SEAT	30A	Driver/Passenger seat manual switch Driver lumbar support switch, IMS control module
KEY SOL	10A	4WD ECM, Rear TPMS initiator LH/RH Rear Parking assist buzzer, Smart key MSCL.
DEICER	15A	Windshield defogger relay, Windshield defogger, BCM
S/ROOF	15A	Sunroof control module
RSE/SMART KEY	10A	Smart key control module
AUDIO 1 (POWER CONNECTOR)	15A	Audio, A/V head module, Tuner module MTS module, Navigation module
ROOM LP (POWER CONNECTOR)	15A	Instrument cluster(Micom, ILL.), Door lamp, Room lamp Power window main switch, Data link connector BCM, Door warning switch, IMS control module Front/Rear A/Con control module, Foot lamp, Map lamp Electro chromic mirror, Front power window switch RH Door scuff lamp inverter, Power tail gate ON/OFF switch Tale gate lamp, Power tale gate control module Power outside mirror motor & defogger LH/RH Cargo lamp, Vanity lamp, Overhead consol lamp Digital clock, Auto light & security indicator, RF receiver Multifunction switch(Light), Tilt & Telescopic module

✘ USE THE DESIGNATED FUSE ONLY

# FUSE & RELAY INFORMATION

## Fuse & Relay Information (3)

SD100-3

E/R SUB BOX(GSL)

LAYOUT

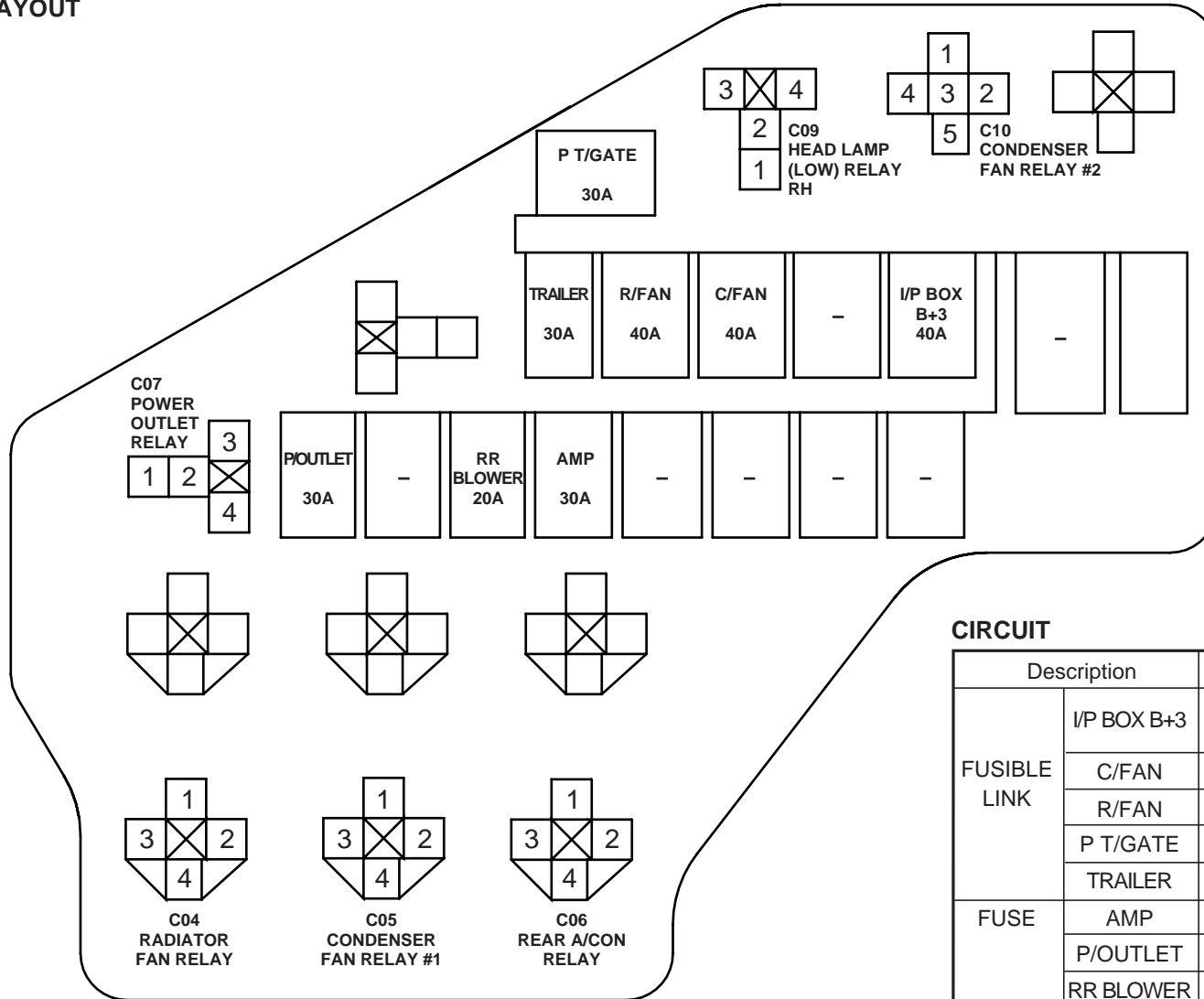

### CIRCUIT

Description		(A)	Circuit Protected
FUSIBLE LINK	I/P BOX B+3	40A	Fuse( RR FOG 15A, FUEL LID 15A, FR WIPER 30A, TILT & TELE 15A, DRL 15A)
	C/FAN	40A	Condenser fan relay #1
	R/FAN	40A	Radiator fan relay
	P T/GATE	30A	Power tail gate control module
	TRAILER	30A	Trailer power outlet
FUSE	AMP	30A	JBL amp
	P/OUTLET	30A	Power outlet relay
	RR BLOWER	20A	Rear A/Con relay

✘ USE THE DESIGNATED FUSE AND RELAY ONLY

# FUSE & RELAY INFORMATION

## Fuse & Relay Information (4)

SD100-4

E/R SUB BOX(DSL)  
LAYOUT

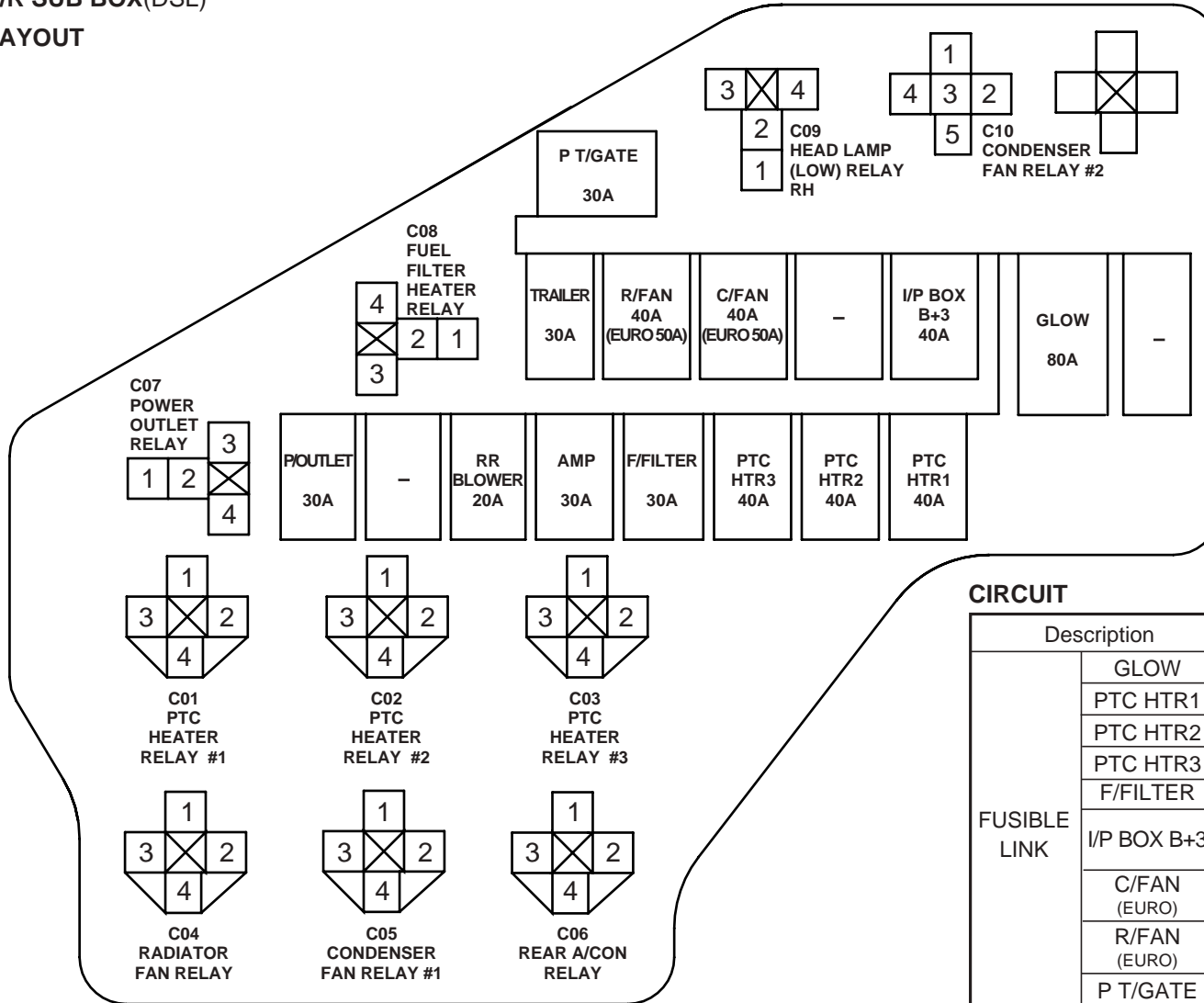

### CIRCUIT

Description		(A)	Circuit Protected
FUSIBLE LINK	GLOW	80A	Glow control module
	PTC HTR1	40A	PTC heater relay #1
	PTC HTR2	40A	PTC heater relay #2
	PTC HTR3	40A	PTC heater relay #3
	F/FILTER	30A	Fuel filter heater relay
	I/P BOX B+3	40A	Fuse(RR FOG 15A, FUEL LID 15A FR WIPER 30A, TILT & TELE 15A, DRL 15A)
	C/FAN (EURO)	40A (50A)	Condenser fan relay #1
	R/FAN (EURO)	40A (50A)	Radiator fan relay
	P T/GATE	30A	Power tail gate control module
	TRAILER	30A	Trailer power outlet
FUSE	AMP	30A	JBL amp
	P/OUTLET	30A	Power outlet relay
	RR BLOWER	20A	Rear A/Con relay

✱ USE THE DESIGNATED FUSE AND RELAY ONLY



# FUSE & RELAY INFORMATION

## Fuse & Relay Information (5)

SD100-5

### E/R JUNCTION BOX LAYOUT

< FRONT >

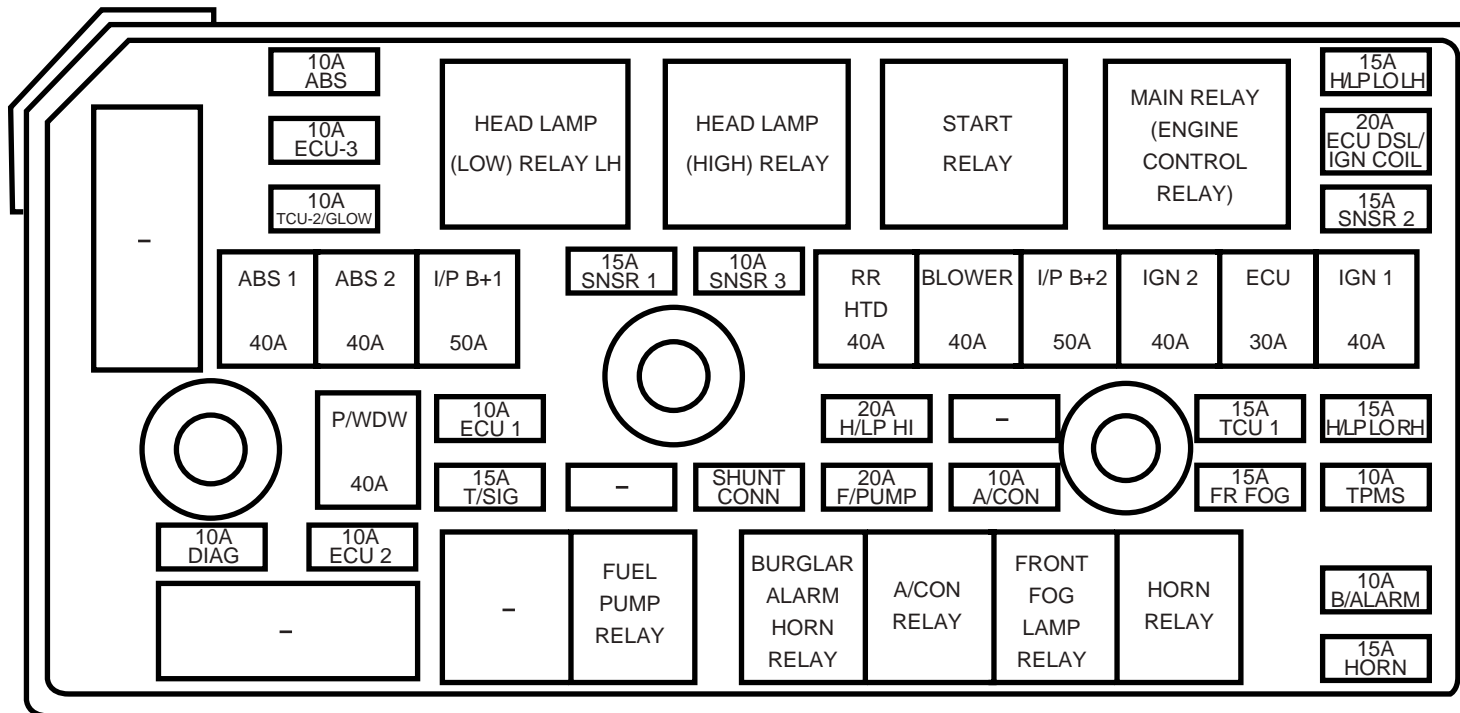

※ USE THE DESIGNATED FUSE AND RELAY ONLY

# FUSE & RELAY INFORMATION

## Fuse & Relay Information (6)

SD100-6

### CIRCUIT

Description		(A)	Circuit Protected
FUSIBLE LINK	IGN 1	40A	Ignition switch(ACC, IG1)
	IGN 2	40A	Start relay, Ignition switch(IG2, START)
	I/P B+1	50A	Fuse(DR LOCK 20A, STOP LP 15A, TAIL LH/RH 10A ADJ-PEDAL 15A, H/LP WASHER 20A)
	I/P B+2	50A	Fuse(P/SEAT 30A, KEY SOL 10A, S/ROOF 15A RSE/SMART KEY 10A, DEICER 15A Power connector(AUDIO1 15A, ROOM LP 15A))
	P/WDW	40A	Fuse(P/WDW LH/RH 25A)
	BLOWER	40A	Blower relay
	RR HTD	40A	Rear defogger relay, Fuse(MIRR HTD 10A)
	ECU	30A	Main relay(Engine control relay), Fuse(ECU DSL 20A(DSL) SNSR2 15A, SNSR1 15A, SNSR3 10A, ECU-2 10A IGN COIL 20A(GSL))
	ABS 1	40A	ABS/ESP control module
	ABS 2	40A	ABS/ESP control module
FUSE	TCU1	15A	TCM
	TPMS	10A	Tire pressure monitoring module, Front TPMS initiator LH/RH Semi active engine mounting solenoid
	B/ALARM	10A	Burglar alarm horn relay
	F/PUMP	20A	Fuel pump relay
	T/SIG	15A	BCM(Hazard lamp)
	A/Con	10A	A/Con relay
	ECU-1	10A	ECM(GSL), Multi-purpose check connector

Description		(A)	Circuit Protected
FUSE	IGN COIL	20A	Ignition coil #1~#6(GSL)
	SNSR1	15A	ECM(GSL), Mass air flow sensor(GSL) Oil control valve(GSL), Fuel metering unit(DSL) EGR actuator(DSL), EVGT actuator(DSL) Immobilizer module, PCSV(GSL), VIV(GSL)
	SNSR2	15A	Fuel pump relay, Oxygen sensor #1~#4(GSL) Rail pressure control valve(DSL)
	SNSR3	10A	A/Con relay, Injector #1~#6(GSL) Condenser fan relay,Radiator fan relay Lambda sensor(DSL)
	ECU-2	10A	ECM(GSL), Stop lamp switch(DSL)
	ECU DSL	20A	ECM(DSL), PTC heater relay #1(DSL)
	H/LP LO RH	15A	Head lamp(Low) relay RH
	H/LP LO LH	15A	Head lamp(Low) relay LH
	H/LP HI	20A	Head lamp(High) relay
	FR FOG	15A	Front fog lamp relay
	HORN	15A	Horn relay
	ABS	10A	ABS/ESP control module, ESP switch
	DIAG	10A	-
	ECU-3	10A	ECM
	TCU-2/ GLOW	10A	TCM, Stop lamp switch(GSL) Glow control module(DSL), Air flow sensor(DSL) Fuel filter warning sensor(DSL)

✘ USE THE DESIGNATED FUSE ONLY



# FUSE & RELAY INFORMATION

## FUSE & RELAY INFORMATION (8)

SD100-8

### ICM RELAY BOX

#### LAYOUT

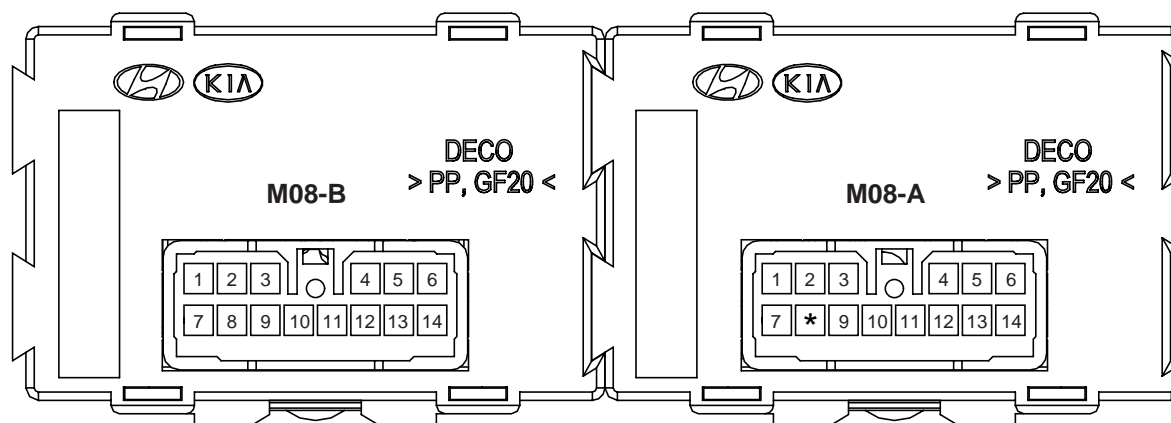
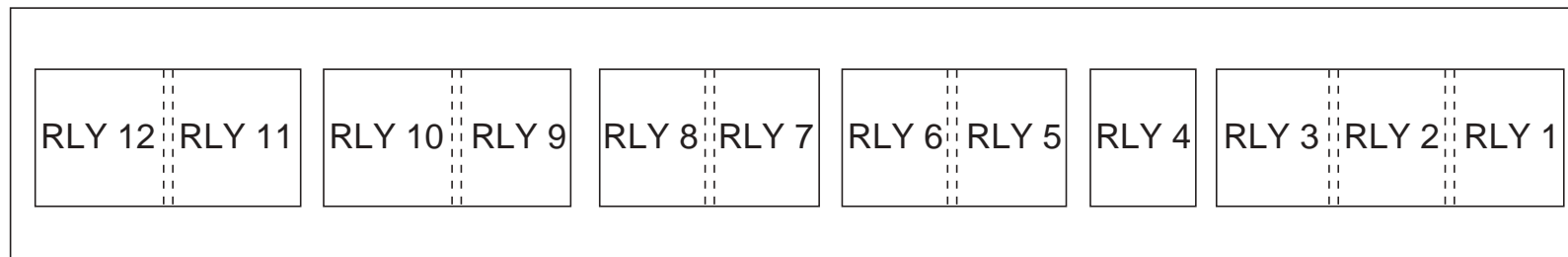

#### RELAY NAME

NO	NAME
RLY 1	Front washer relay
RLY 2	Front wiper relay
RLY 3	Power tail gate relay(With Power T/Gate), Tail gate lock actuator relay(W/O Power T/Gate)
RLY 4	Rear fog lamp relay(Except Euro), Head lamp washer relay(Euro)
RLY 5	Rear seat warmer relay RH(Except Euro), Head lamp washer relay(GEN/MES)
RLY 6	Rear seat warmer relay LH(Except Euro)
RLY 7	Not used
RLY 8	Not used
RLY 9	Rear seat warmer relay RH(Euro)
RLY 10	Rear seat warmer relay LH(Euro)
RLY 11	DRL relay(Euro)
RLY 12	Rear fog lamp relay(Euro)

#### CIRCUIT

CONNECTOR	PIN NO.	RELAY
M08-A	1	RLY 1 / RLY 2
	2	RLY 2
	3	RLY 2
	4	RLY 3
	5	RLY 3
	6	RLY 4
	7	RLY 1
	8	-
	9	RLY 2
	10	RLY 1
	11	RLY 3
	12	RLY 3
	13	RLY 4
	14	RLY 4
M08-B	1	RLY 9 / RLY 10
	2	RLY 6 (Except Euro) RLY 10 (Euro)
	3	RLY 6 (Except Euro) RLY 10 (Euro)
	4	RLY 11
	5	RLY 11
	6	RLY 12
	7	RLY 5 (Except Euro) RLY 9 (Euro)
	8	RLY 5
	9	RLY 5 (Except Euro) RLY 10 (Euro)
	10	RLY 6 (Except Euro) RLY 9 (Euro)
	11	RLY 11
	12	RLY 11
	13	RLY 12
	14	RLY 12

# POWER DISTRIBUTION

E527FE26

## Power Distribution (1)

SD110-1

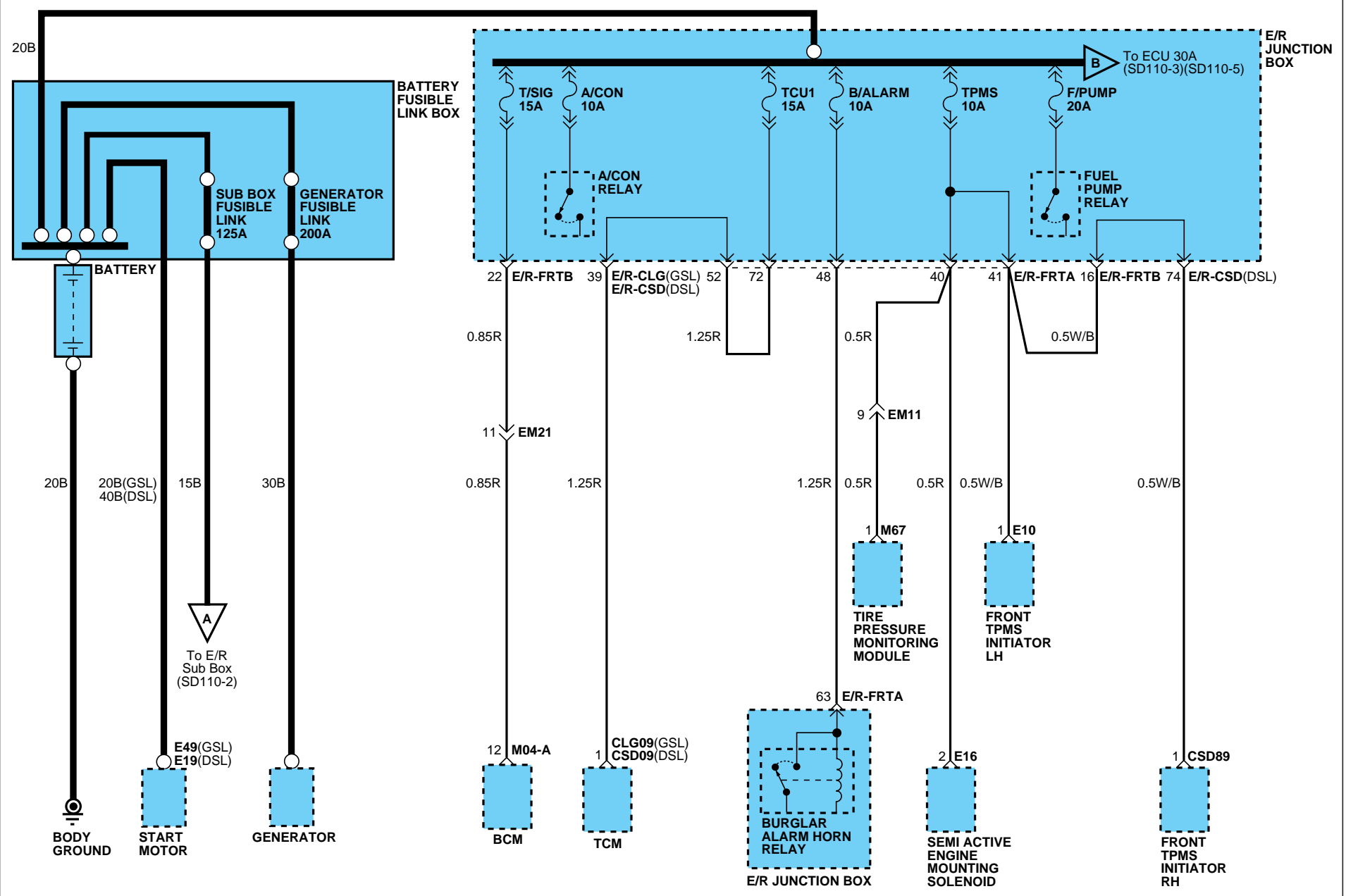

# POWER DISTRIBUTION

## Power Distribution (2)

SD110-2

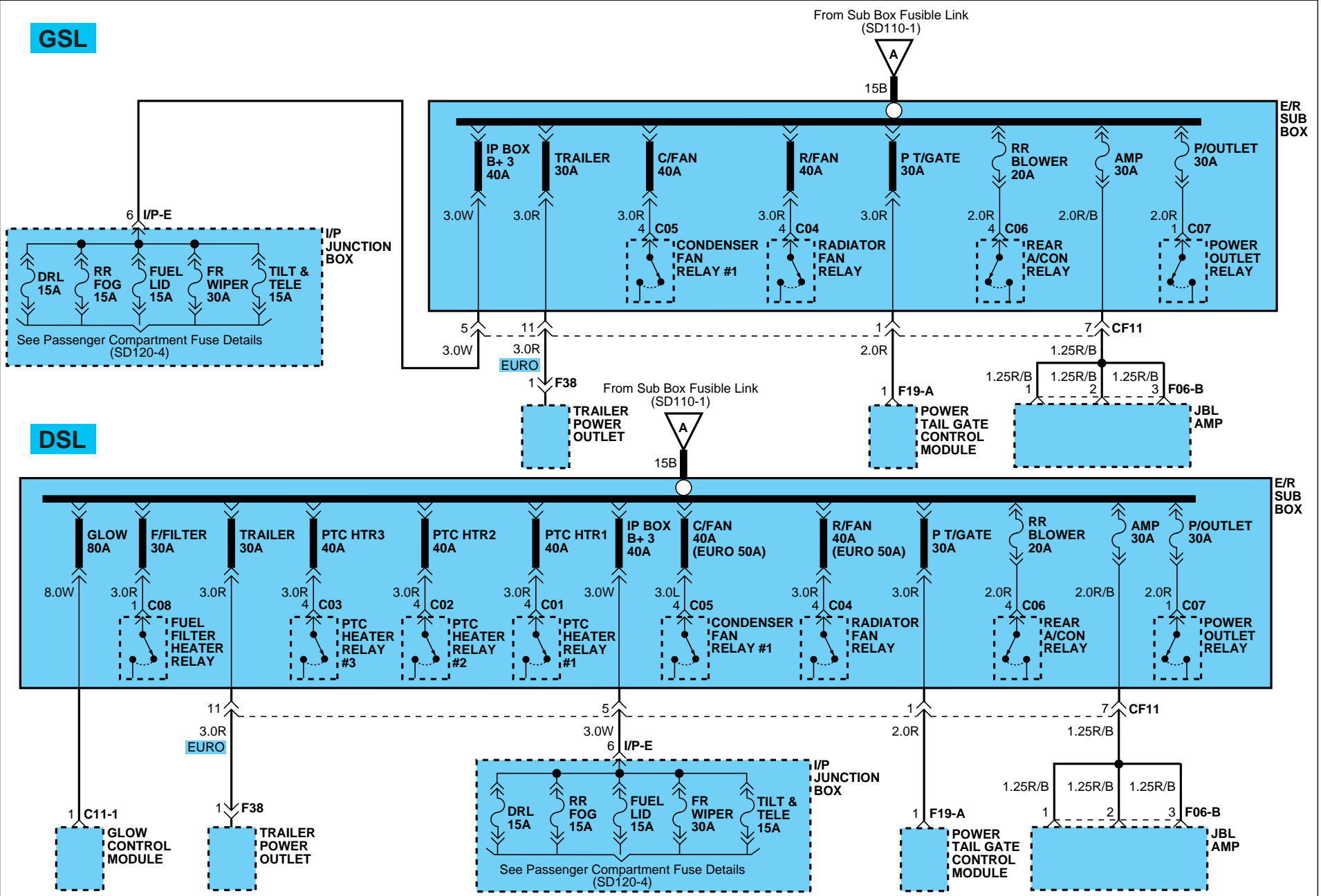

# POWER DISTRIBUTION

## Power Distribution (3)

SD110-3

GSL

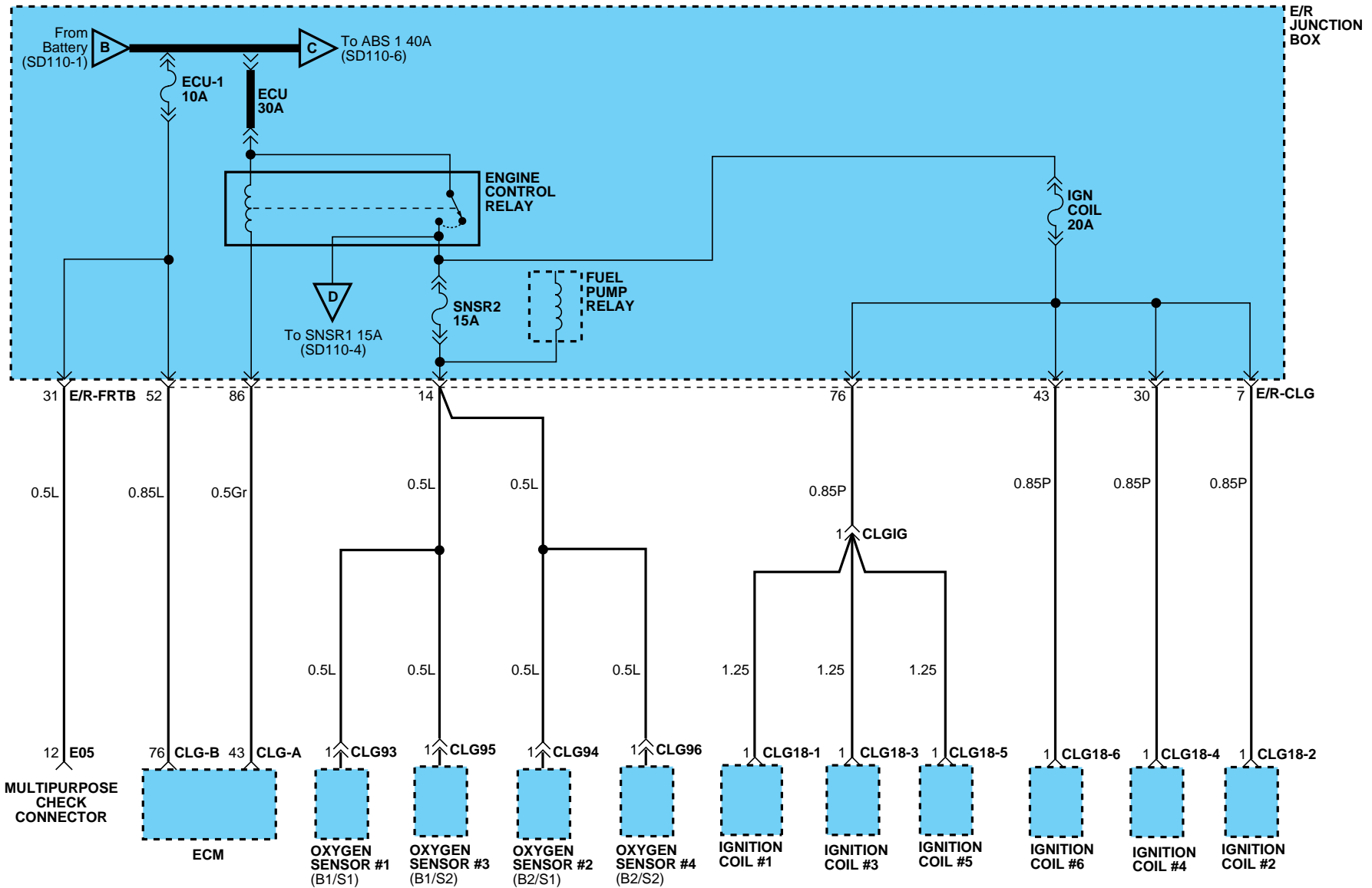

# POWER DISTRIBUTION

## Power Distribution (4)

SD110-4

**GSL**

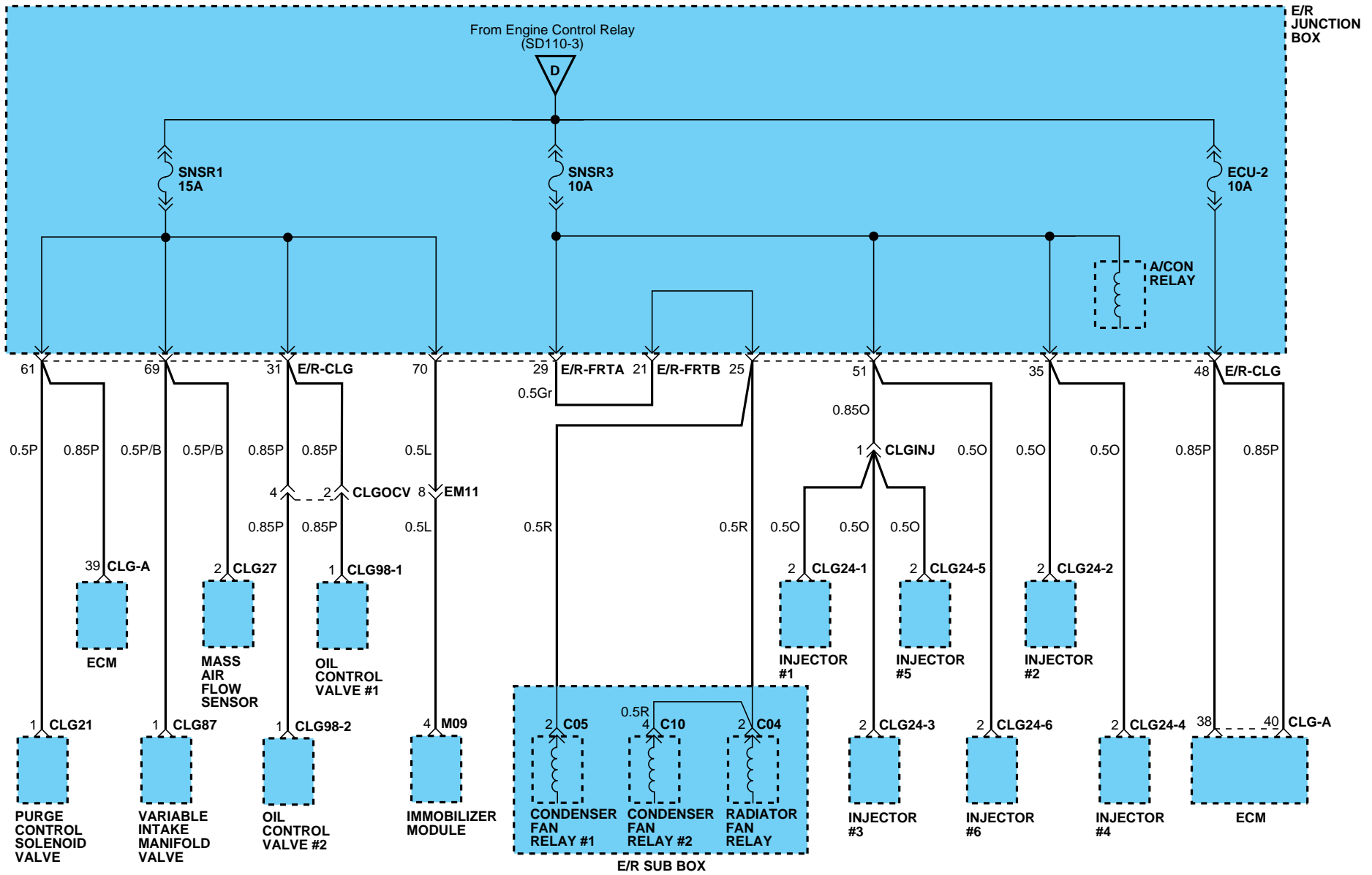



# POWER DISTRIBUTION

## Power Distribution (5)

SD110-5

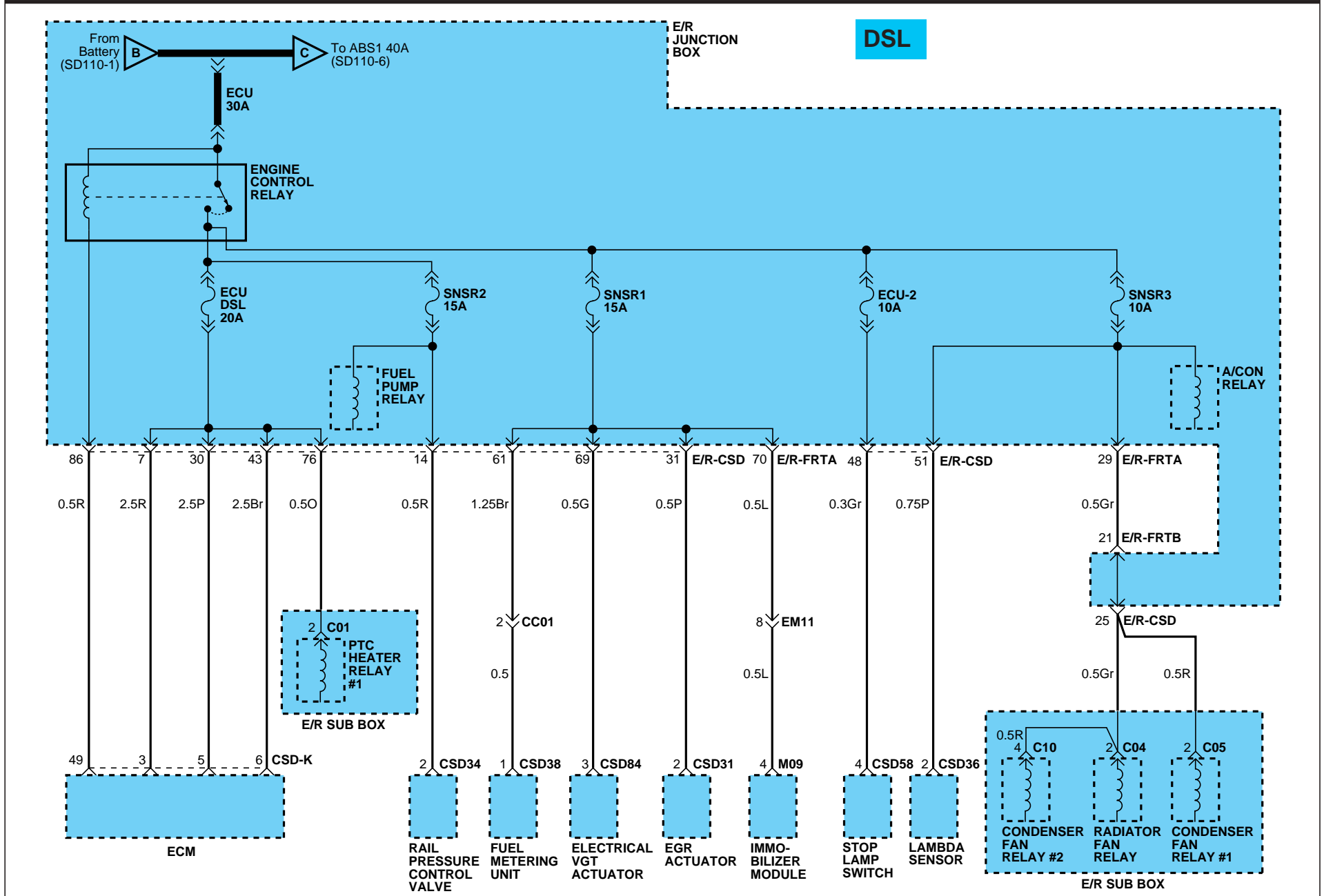

# POWER DISTRIBUTION

## Power Distribution (6)

SD110-6

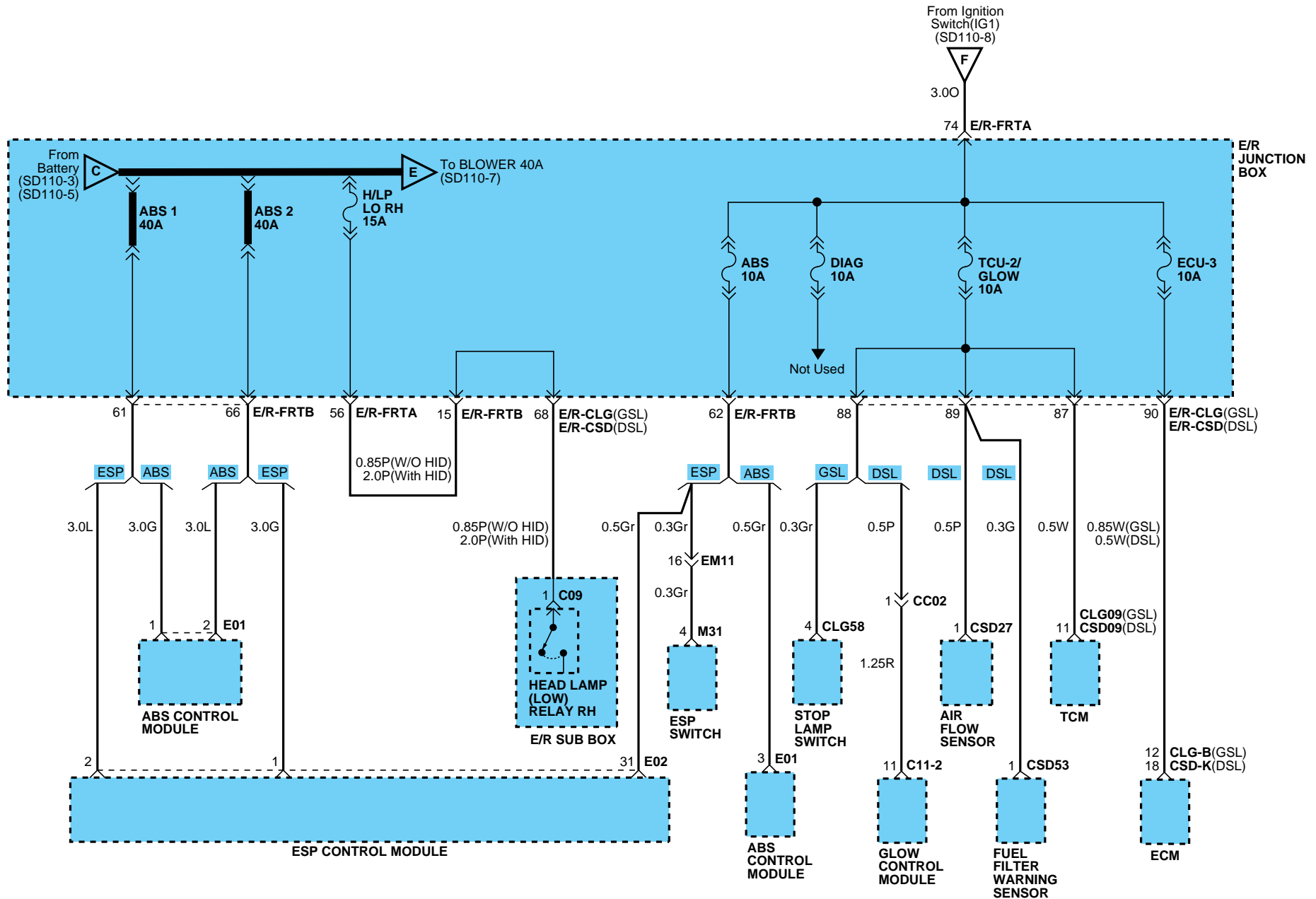

# POWER DISTRIBUTION

## Power Distribution (7)

SD110-7

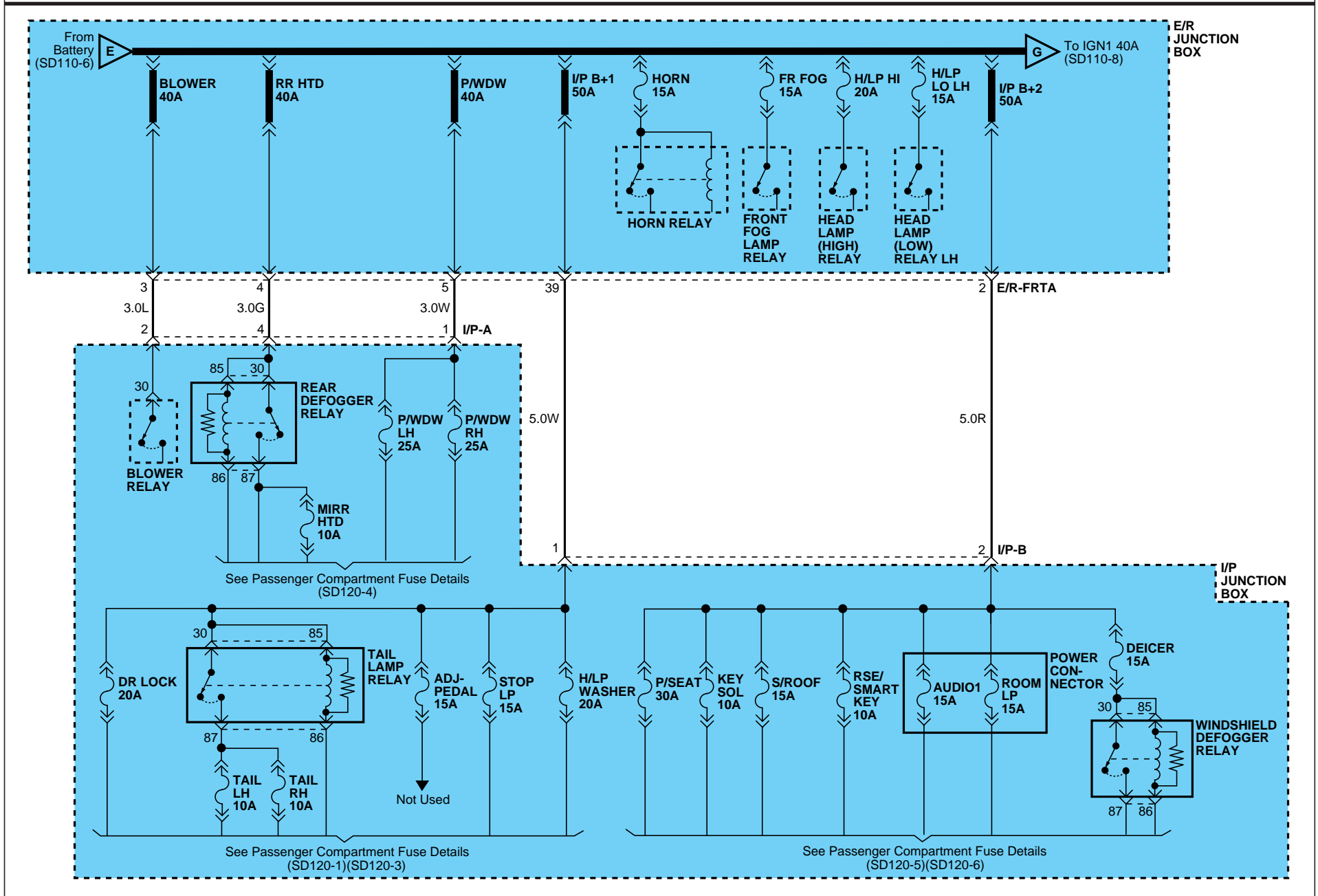

# POWER DISTRIBUTION

## Power Distribution (8)

SD110-8

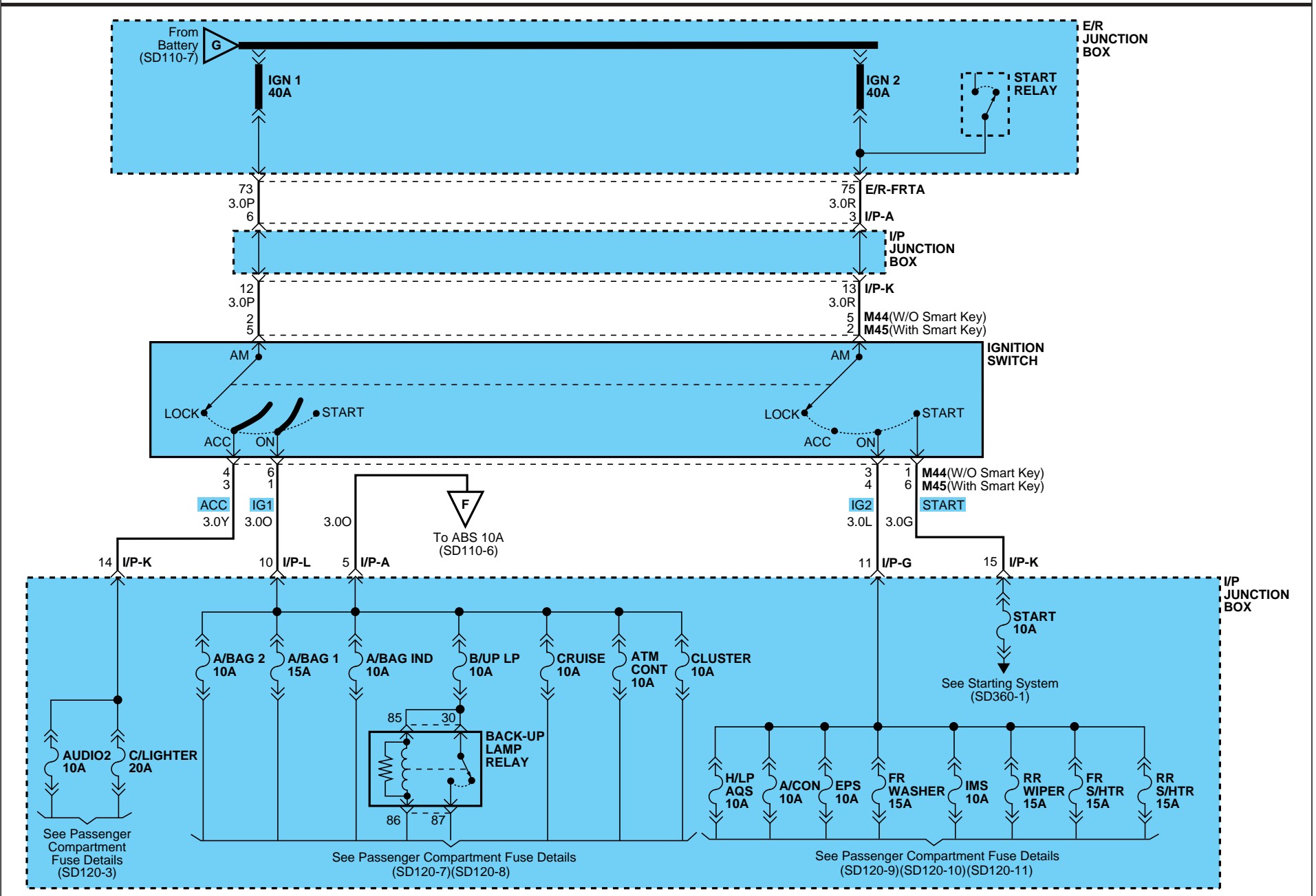



# PASSENGER COMPARTMENT FUSE DETAILS

## Passenger Compartment Fuse Details (2)

SD120-2

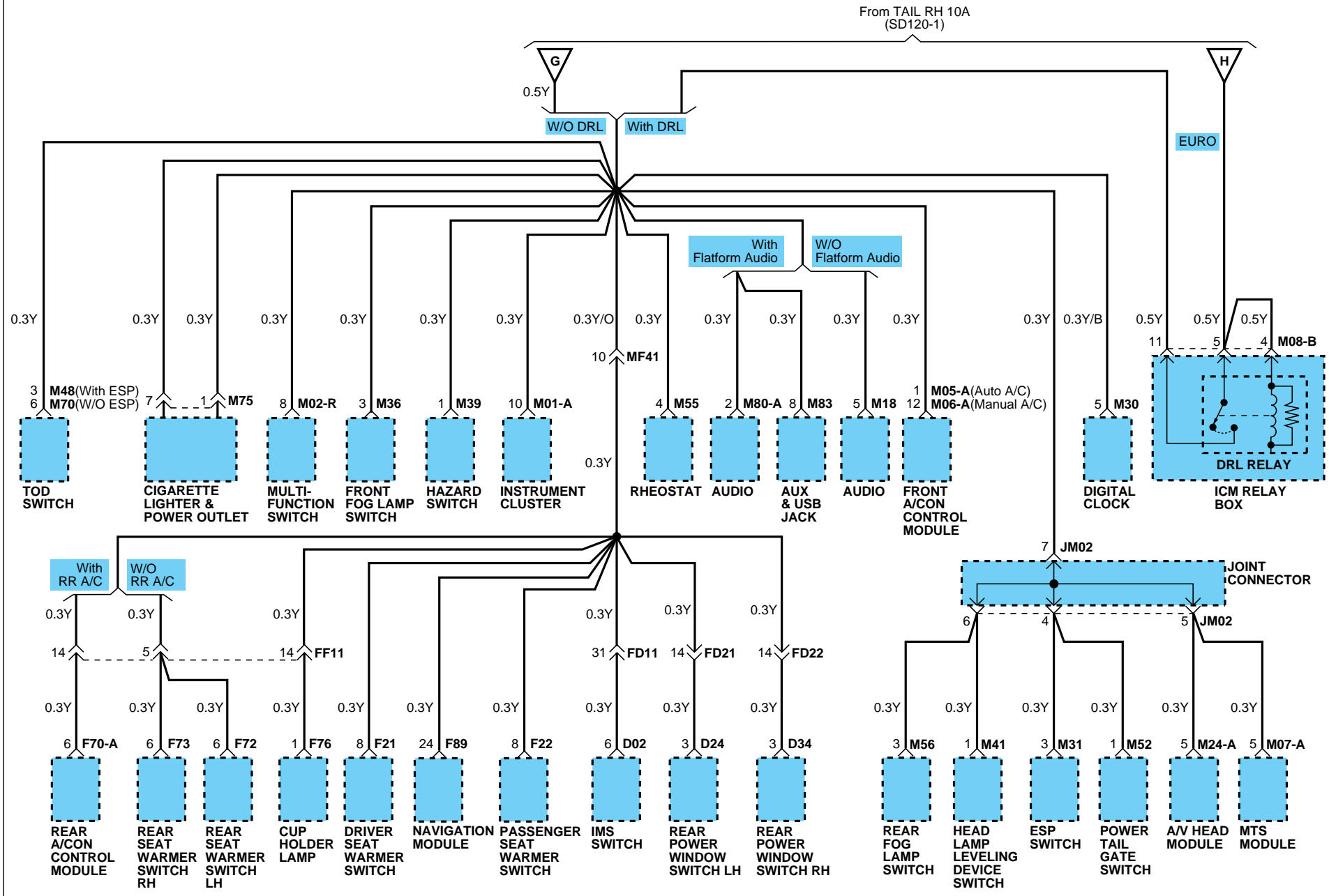

# PASSENGER COMPARTMENT FUSE DETAILS

## Passenger Compartment Fuse Details (3)

SD120-3

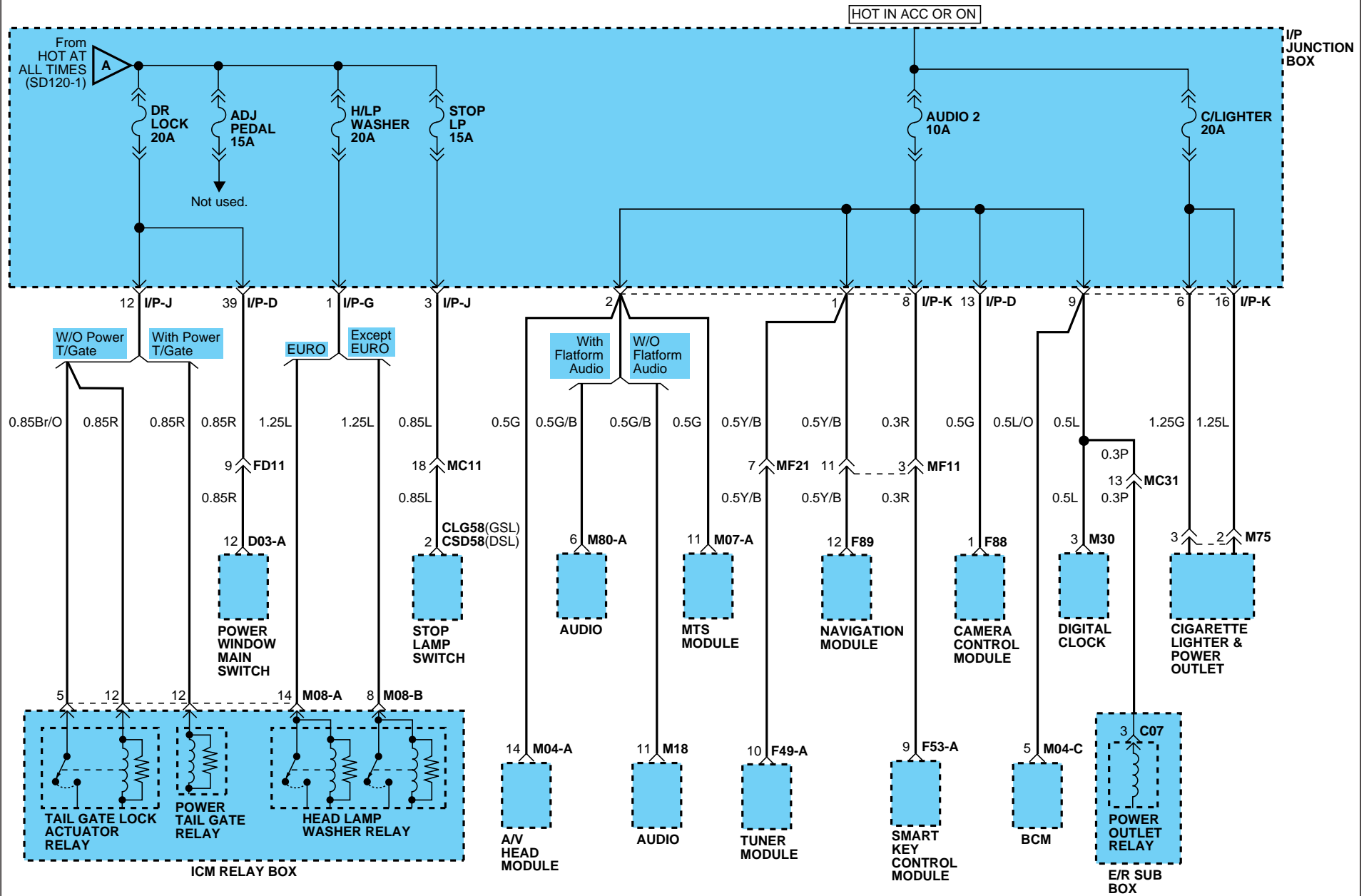

# PASSENGER COMPARTMENT FUSE DETAILS

## Passenger Compartment Fuse Details (4)

SD120-4

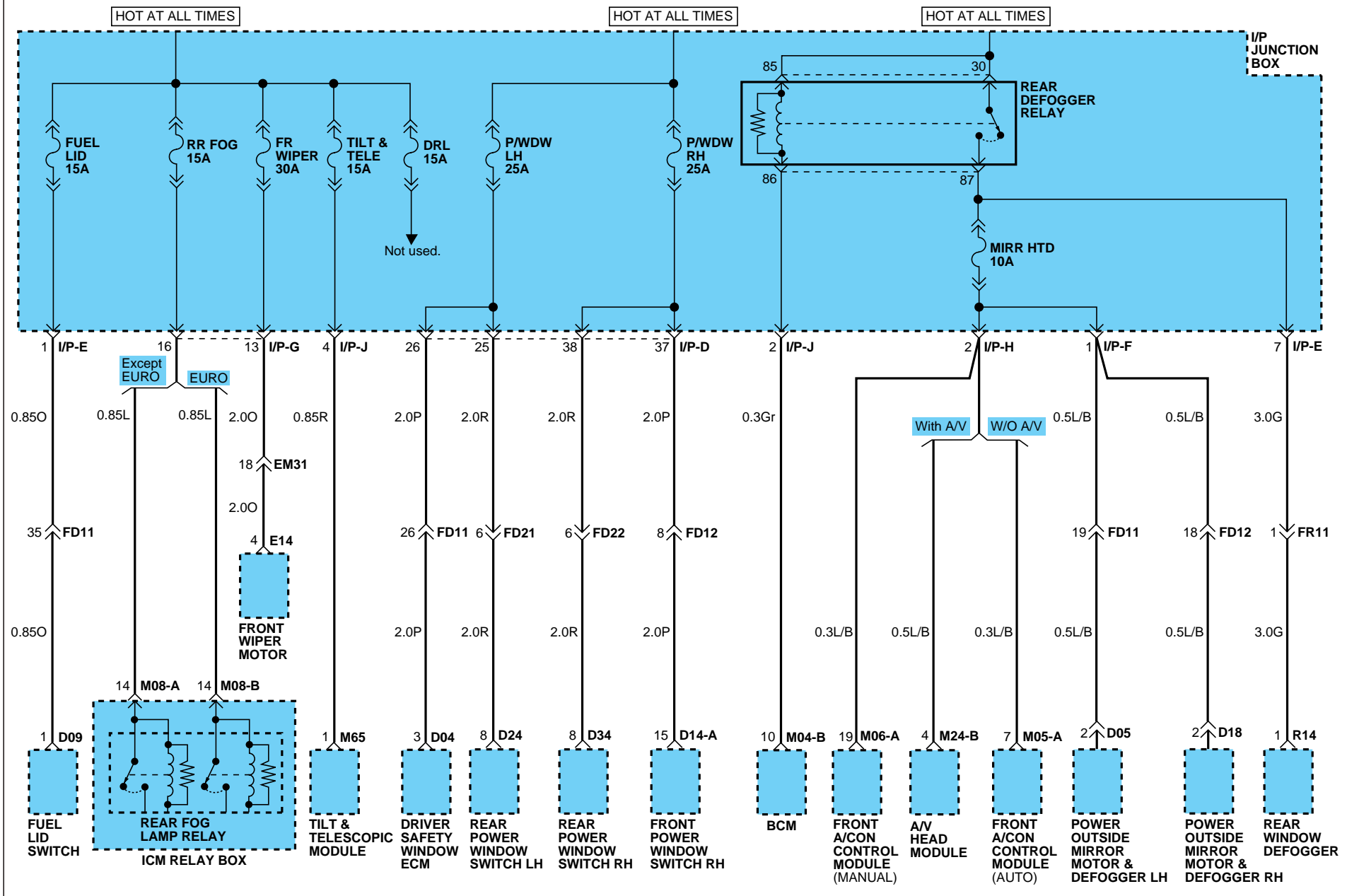



# PASSENGER COMPARTMENT FUSE DETAILS

## Passenger Compartment Fuse Details (5)

SD120-5

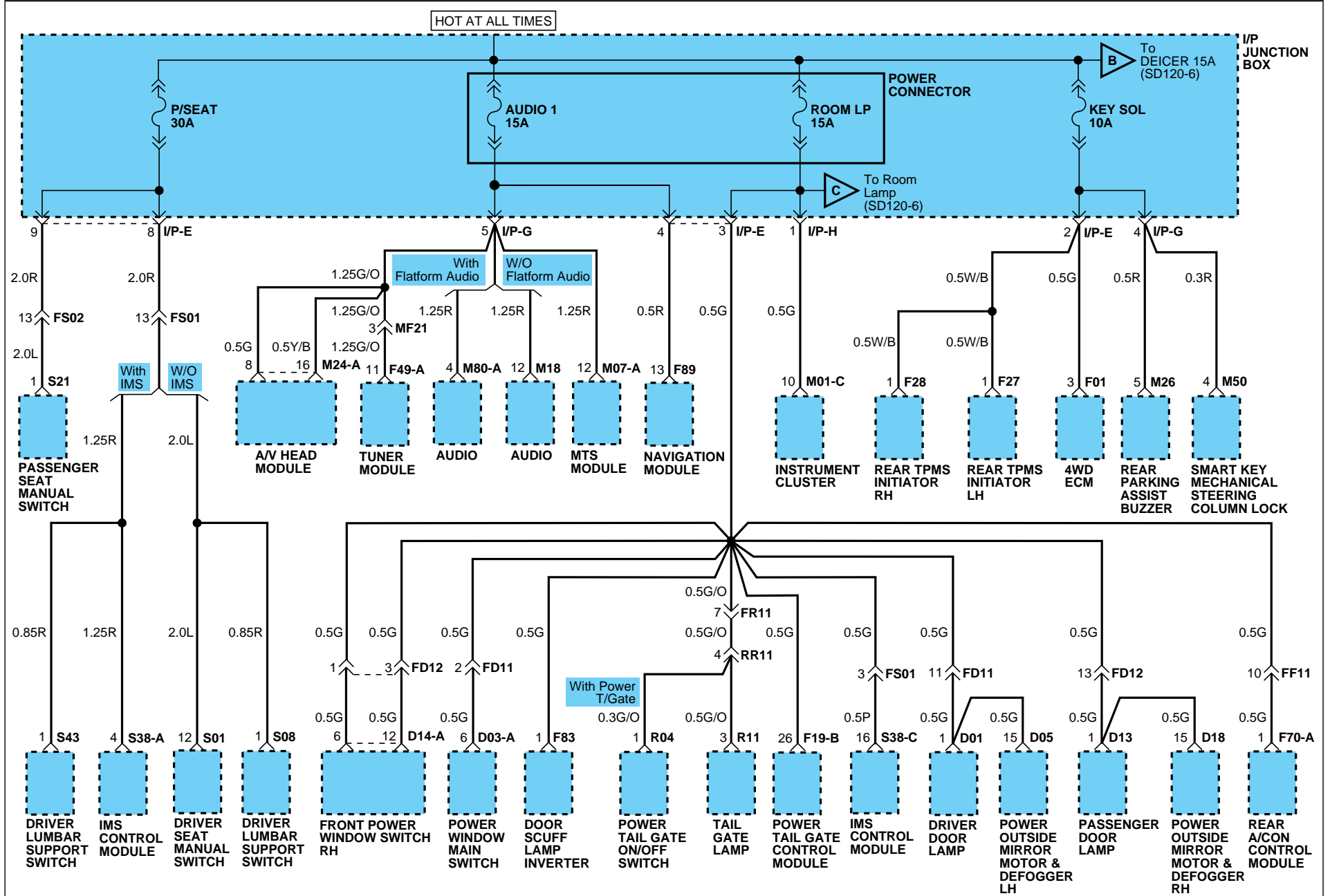

# PASSENGER COMPARTMENT FUSE DETAILS

## Passenger Compartment Fuse Details (6)

SD120-6

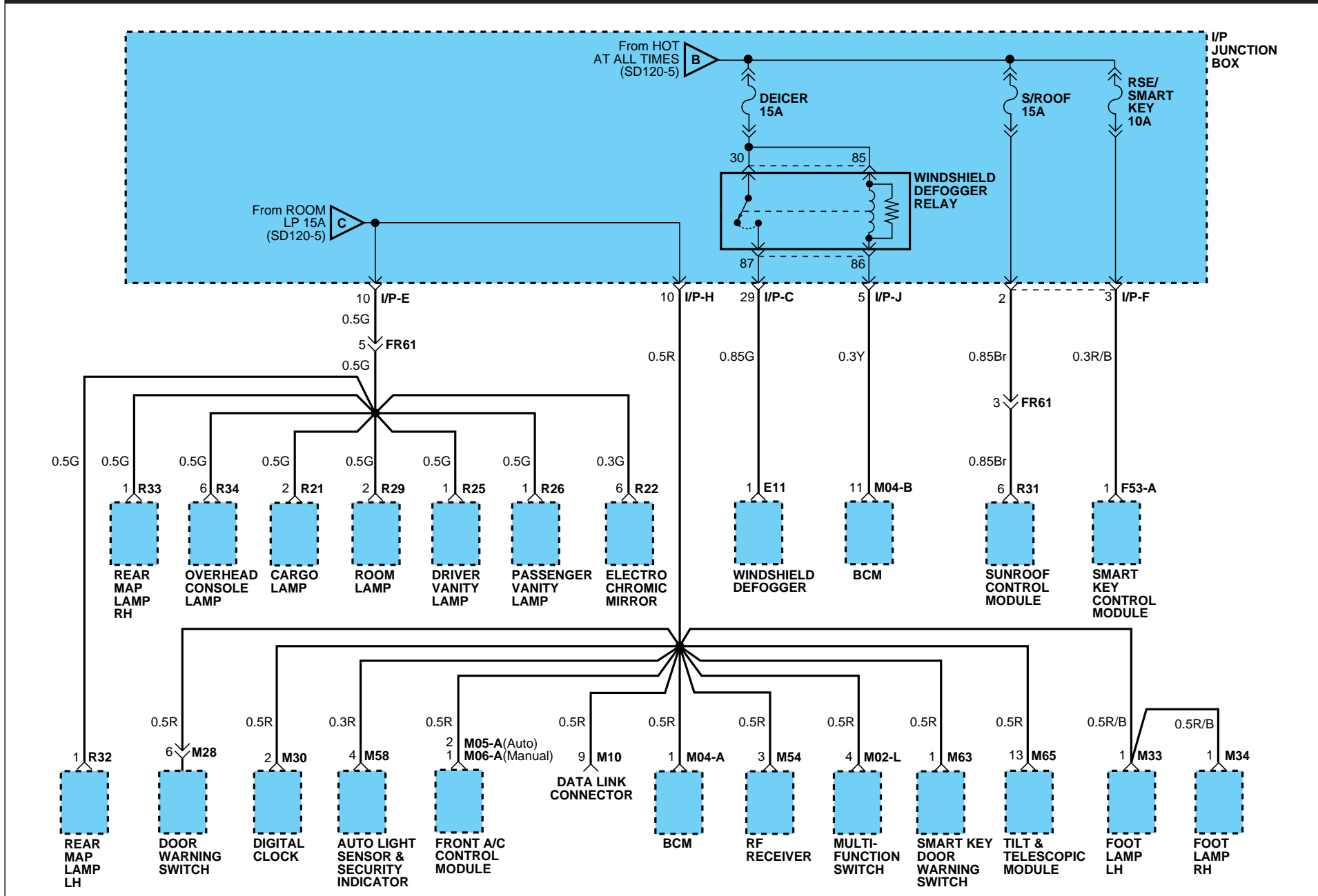

# PASSENGER COMPARTMENT FUSE DETAILS

## Passenger Compartment Fuse Details (7)

SD120-7

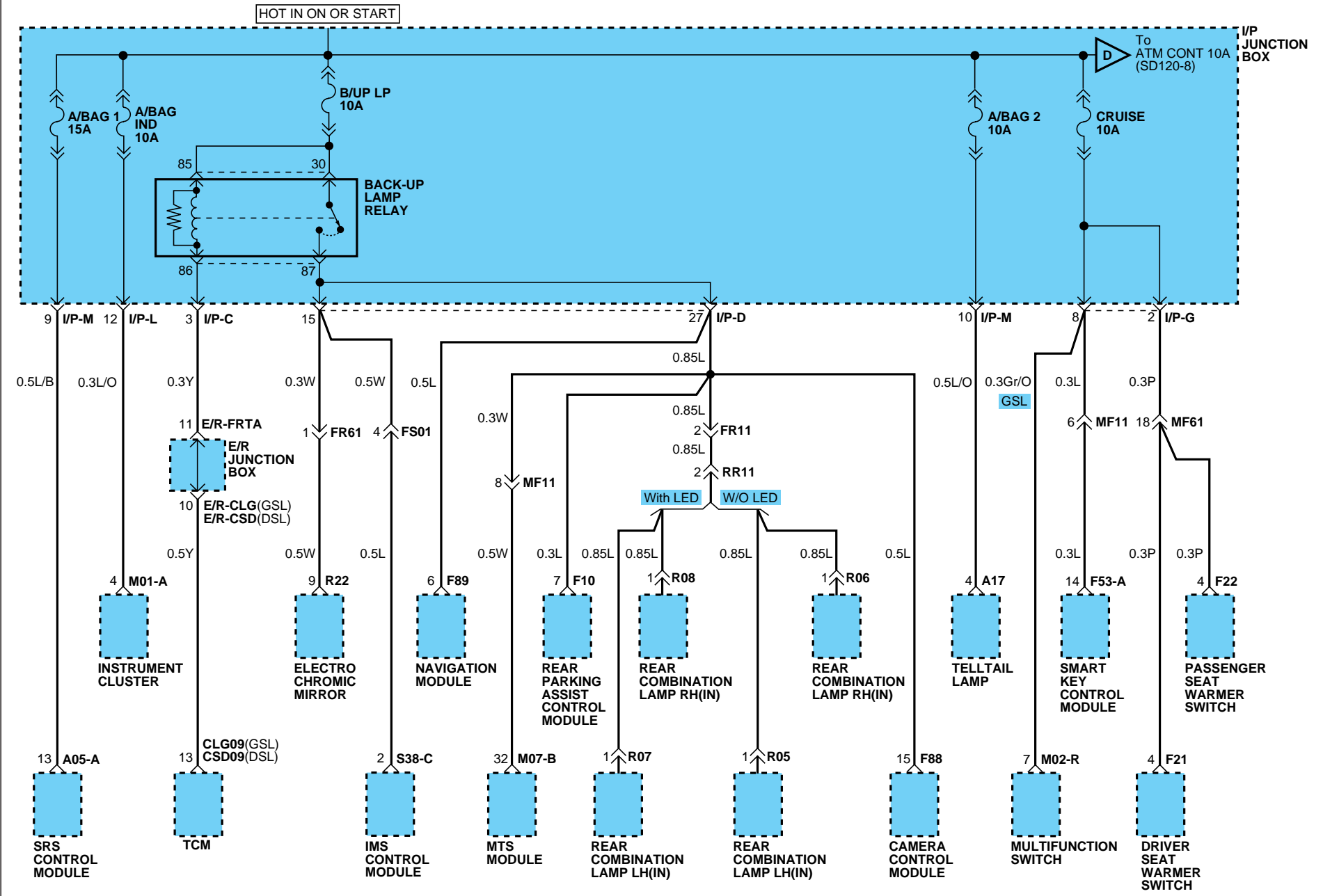

# PASSENGER COMPARTMENT FUSE DETAILS

## Passenger Compartment Fuse Details (8)

SD120-8

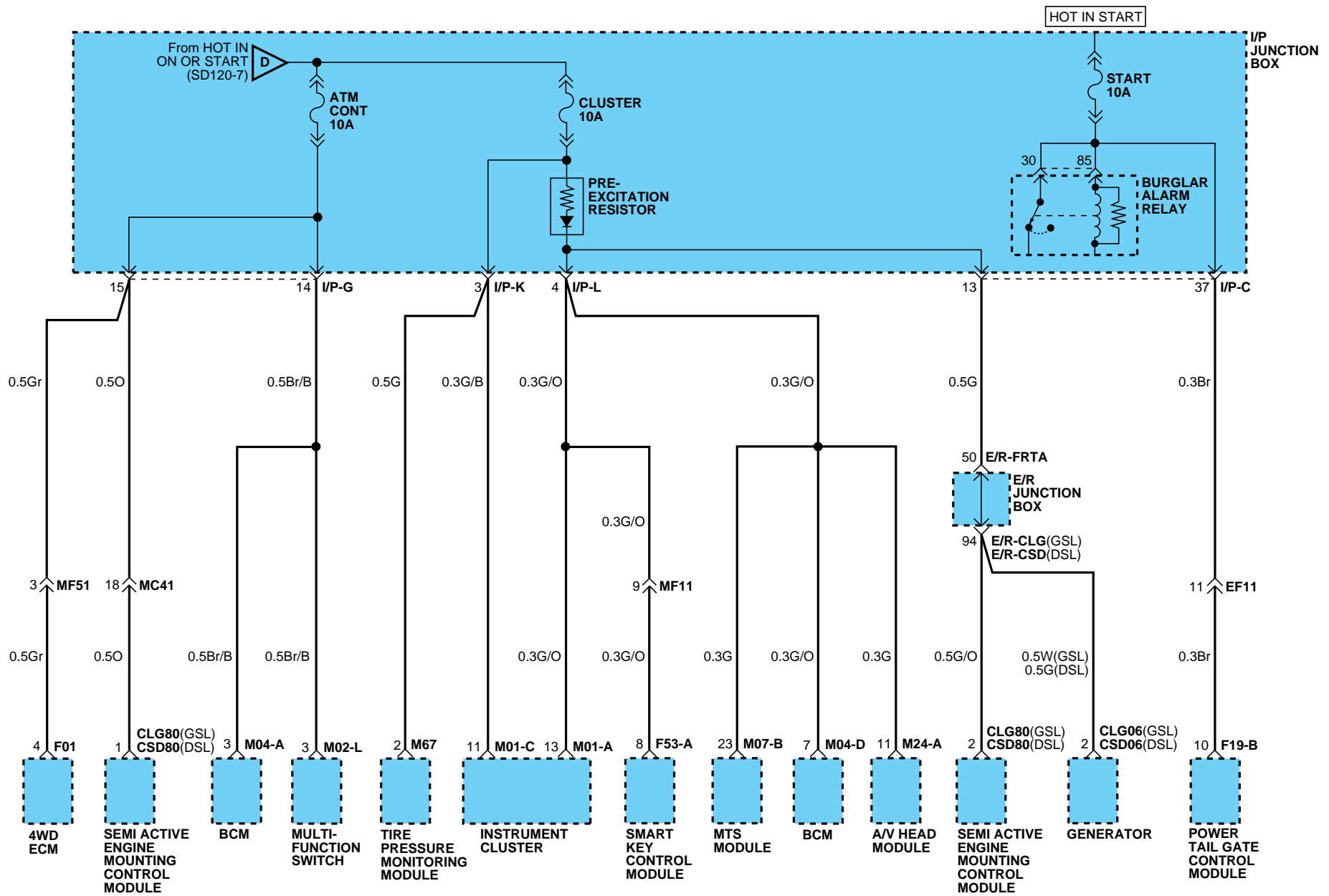

# PASSENGER COMPARTMENT FUSE DETAILS

## Passenger Compartment Fuse Details (9)

SD120-9

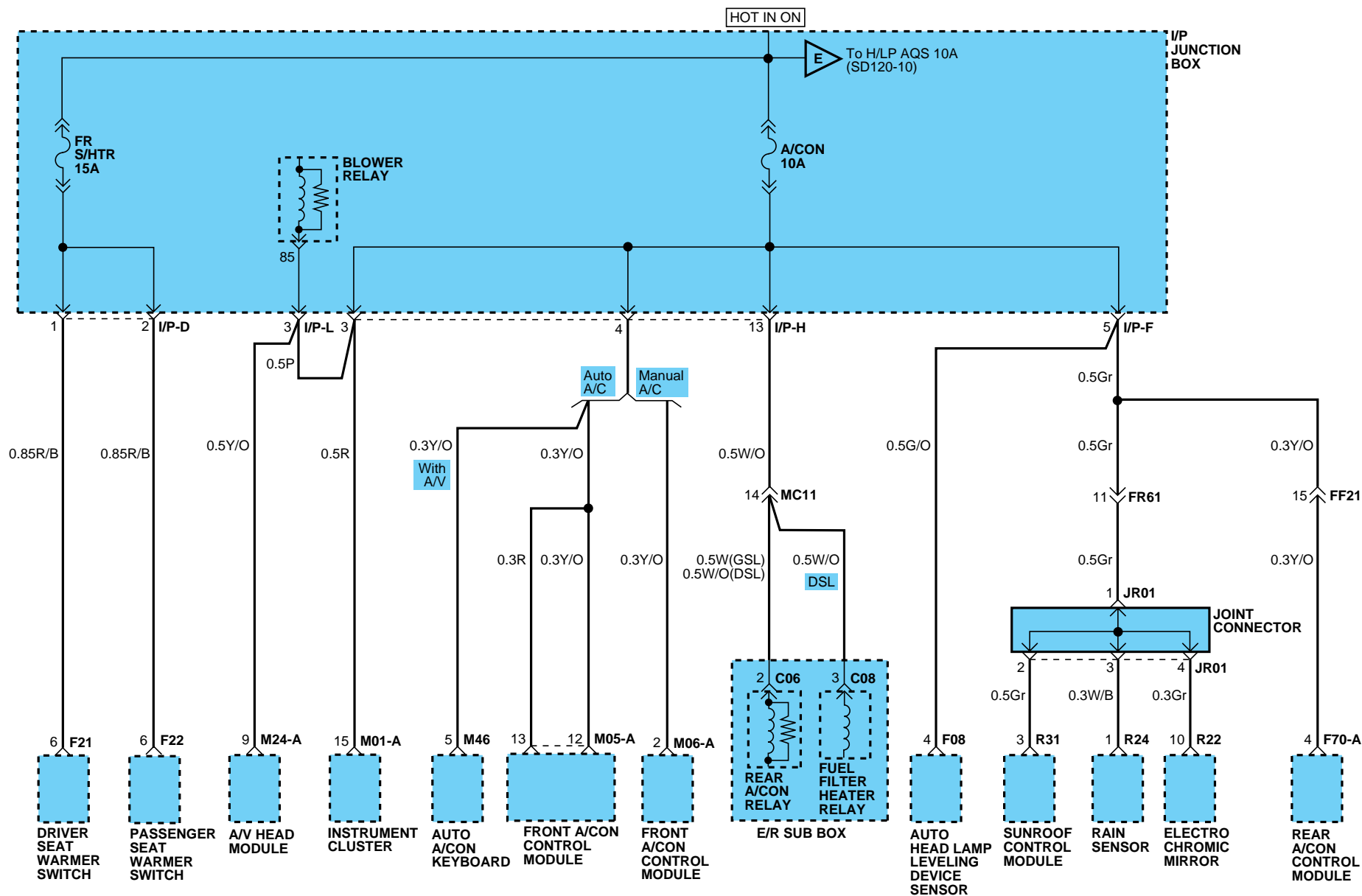

# PASSENGER COMPARTMENT FUSE DETAILS

## Passenger Compartment Fuse Details (10)

SD120-10

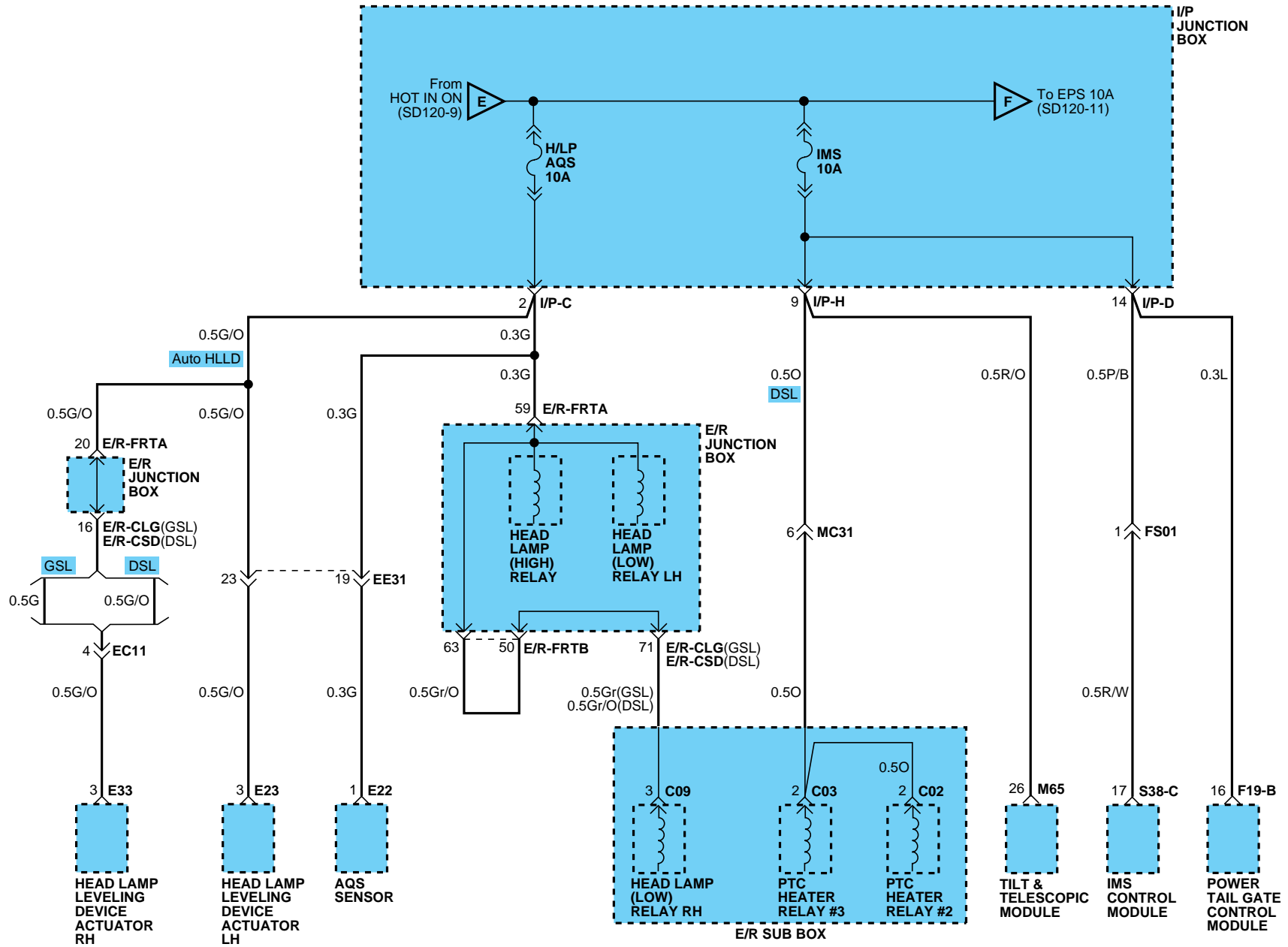



**PASSENGER COMPARTMENT FUSE DETAILS**

Passenger Compartment Fuse Details (12)

**SD120-12**

**MEMO**



# GROUND DISTRIBUTION

EACDDBDA

## Ground Distribution (1)

SD130-1

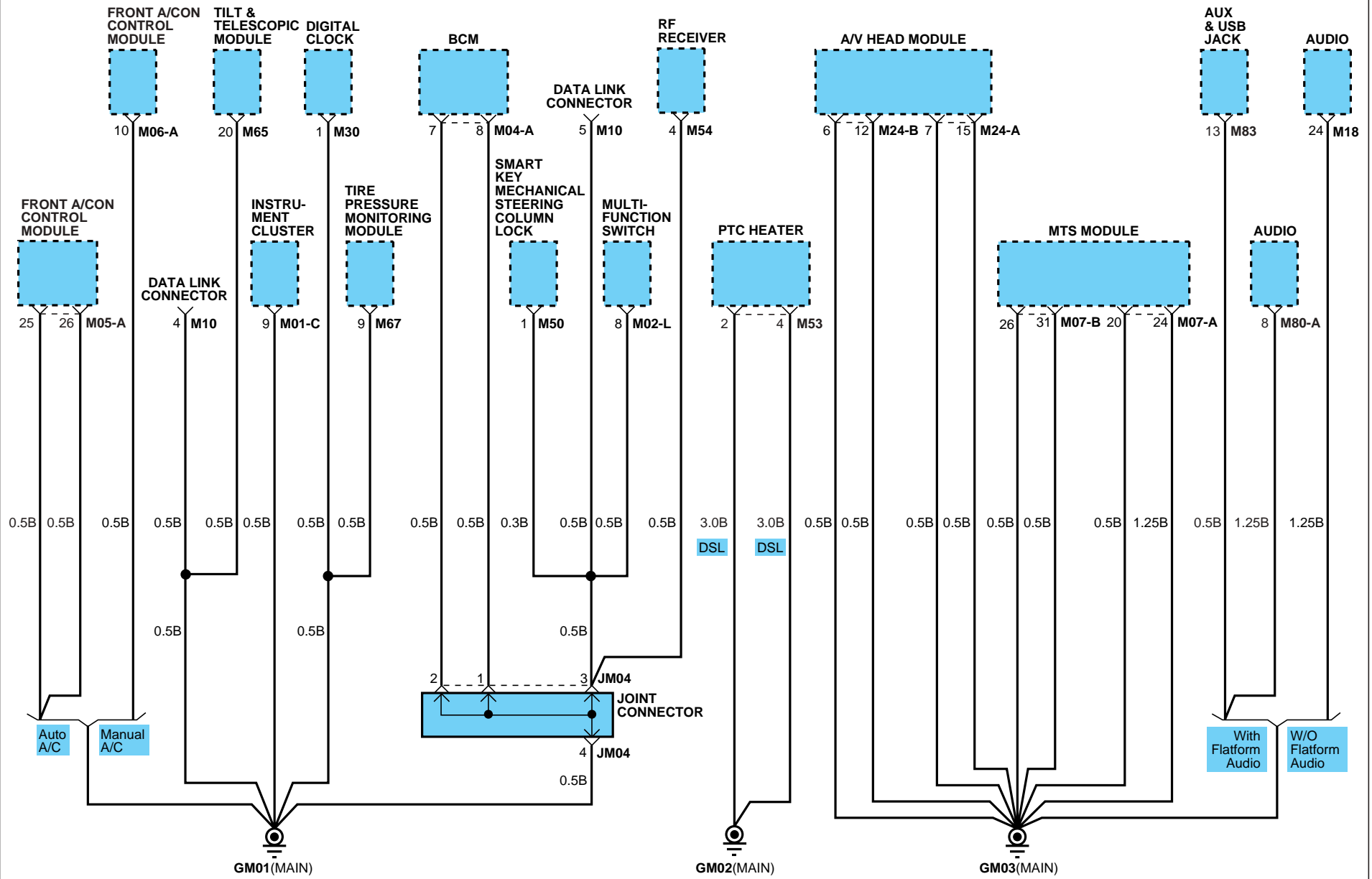

# GROUND DISTRIBUTION

## Ground Distribution (2)

SD130-2

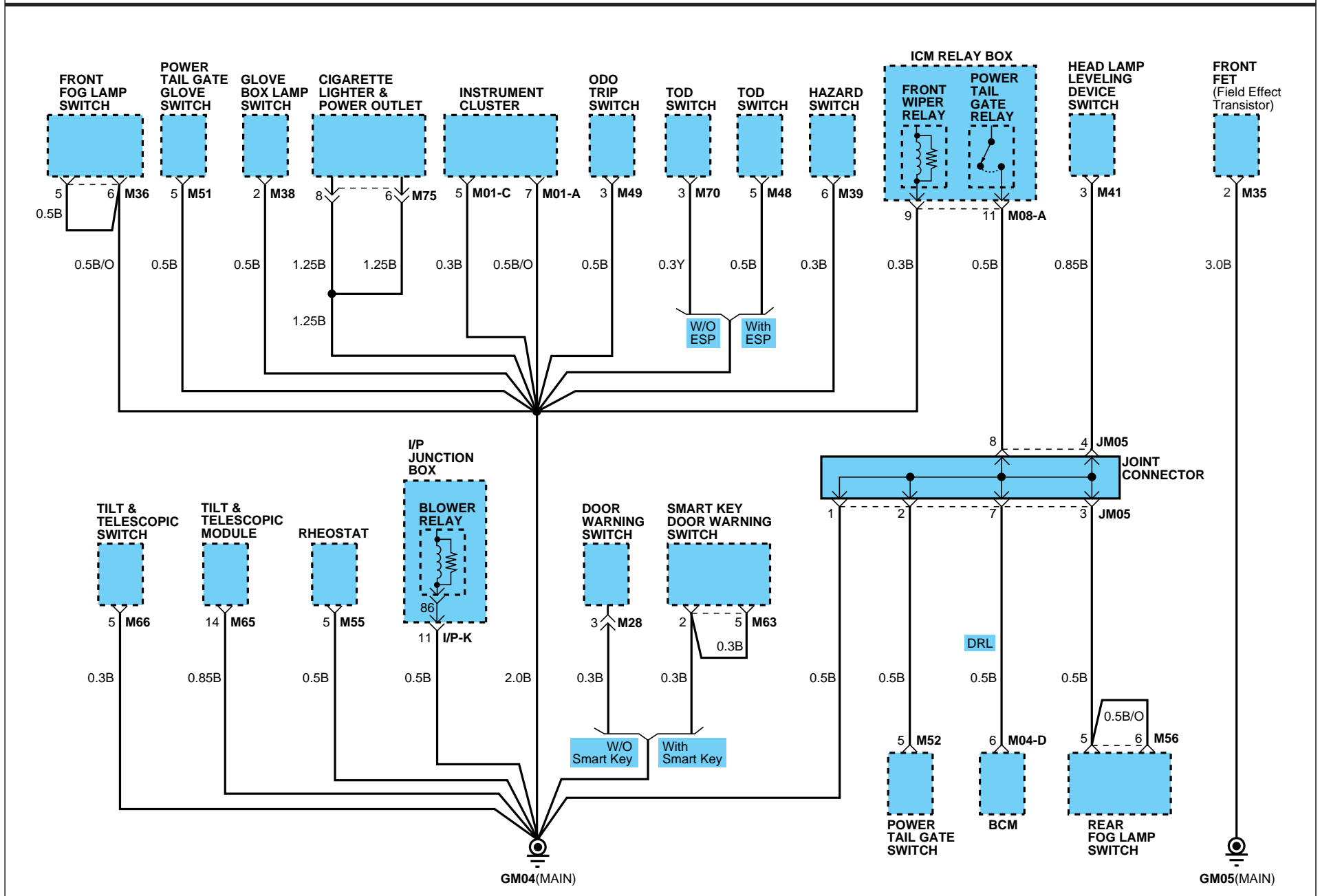

# GROUND DISTRIBUTION

## Ground Distribution (3)

SD130-3

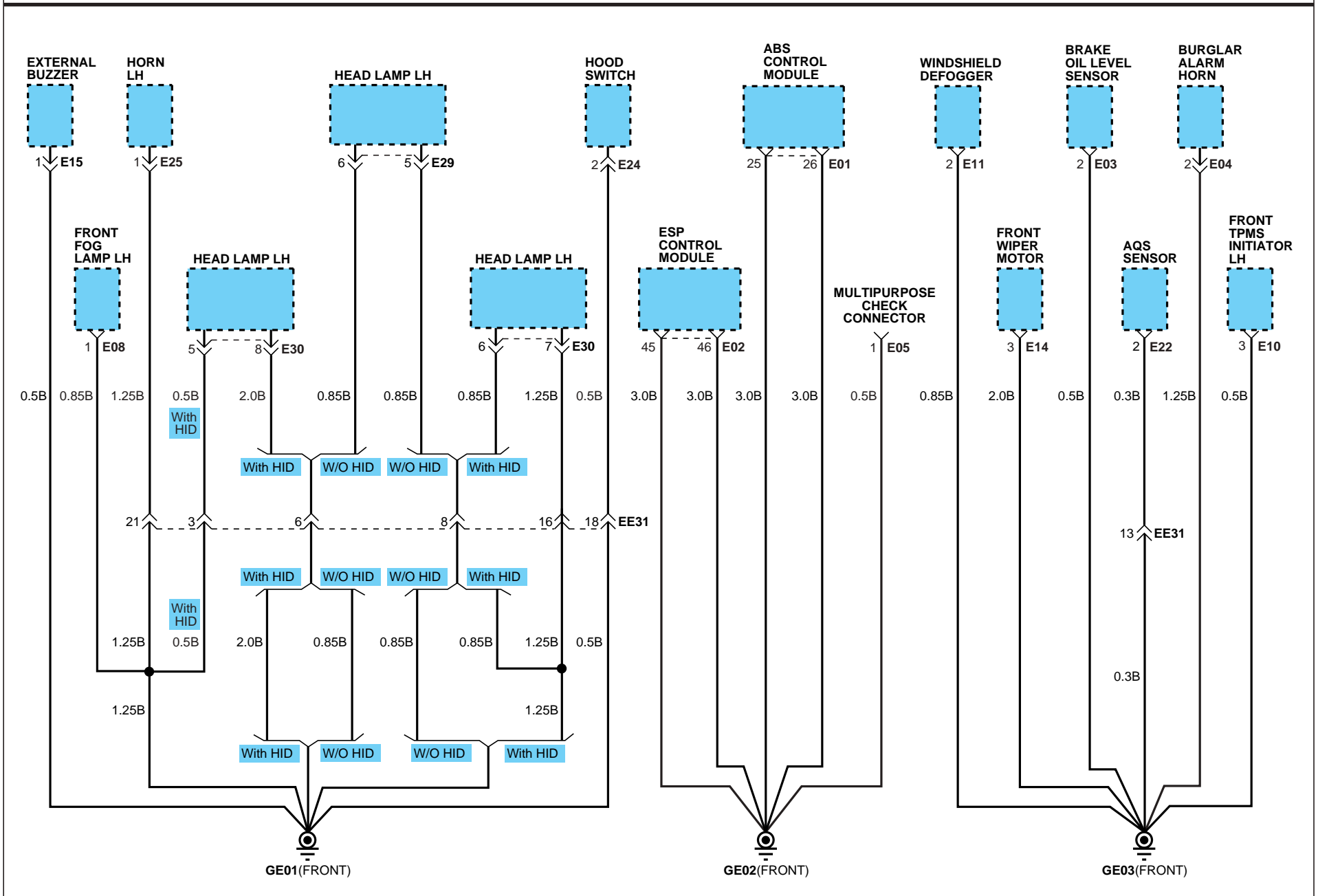

# GROUND DISTRIBUTION

## Ground Distribution (4)

SD130-4

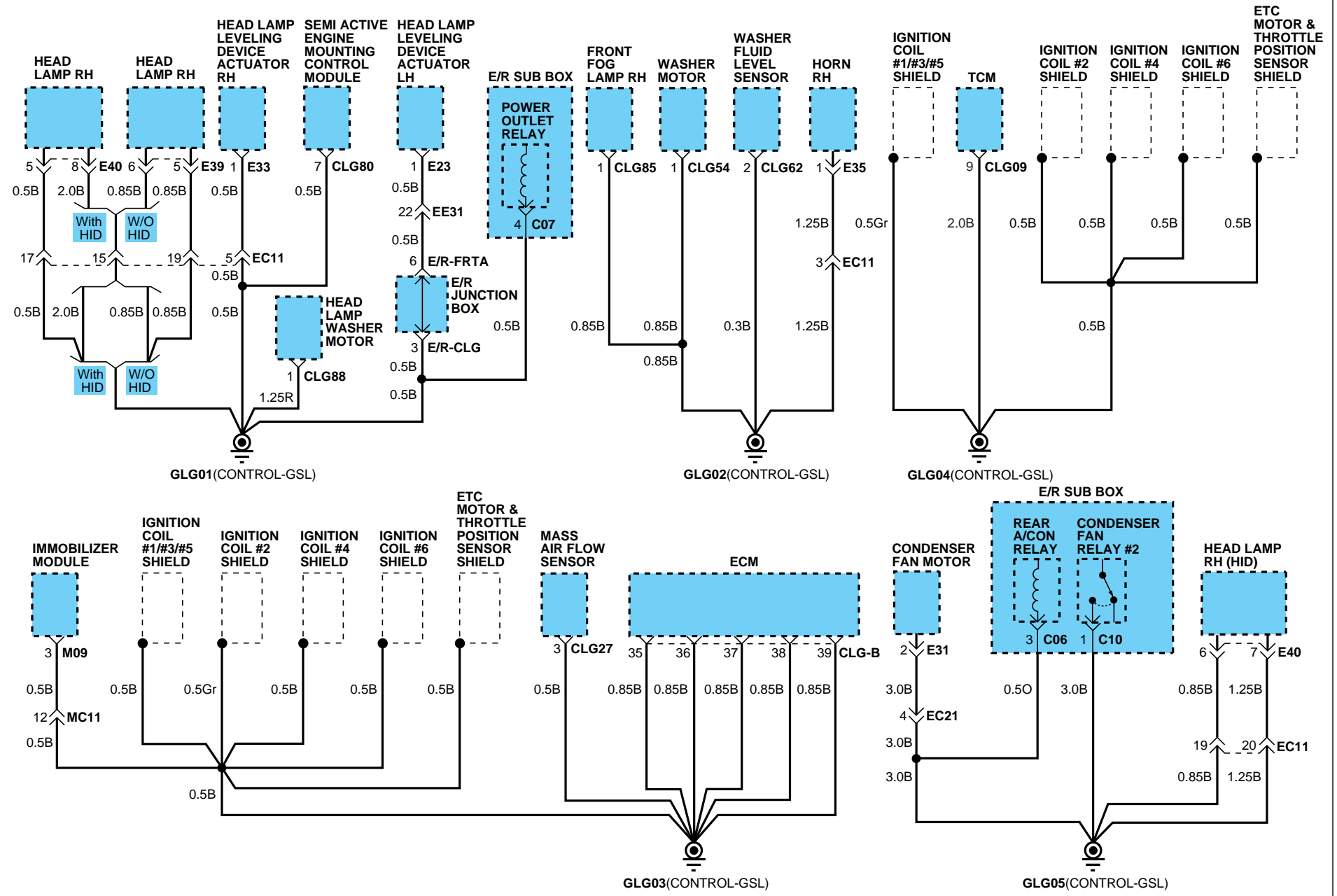

# GROUND DISTRIBUTION

## Ground Distribution (5)

SD130-5

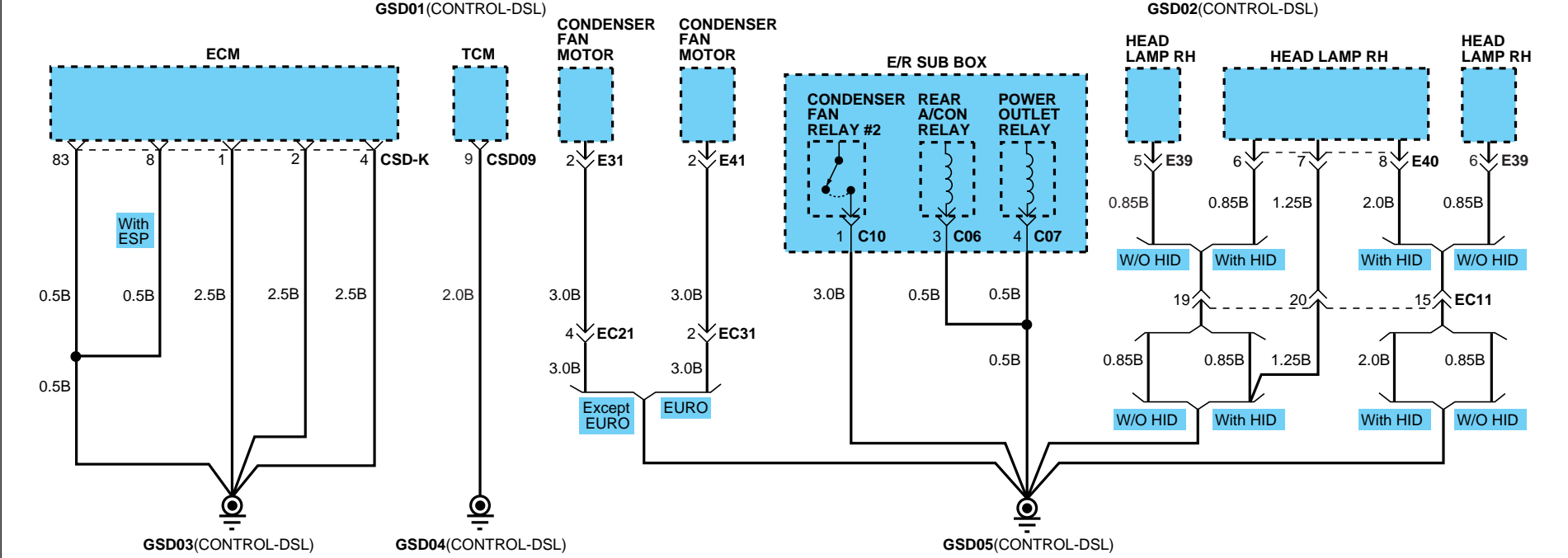
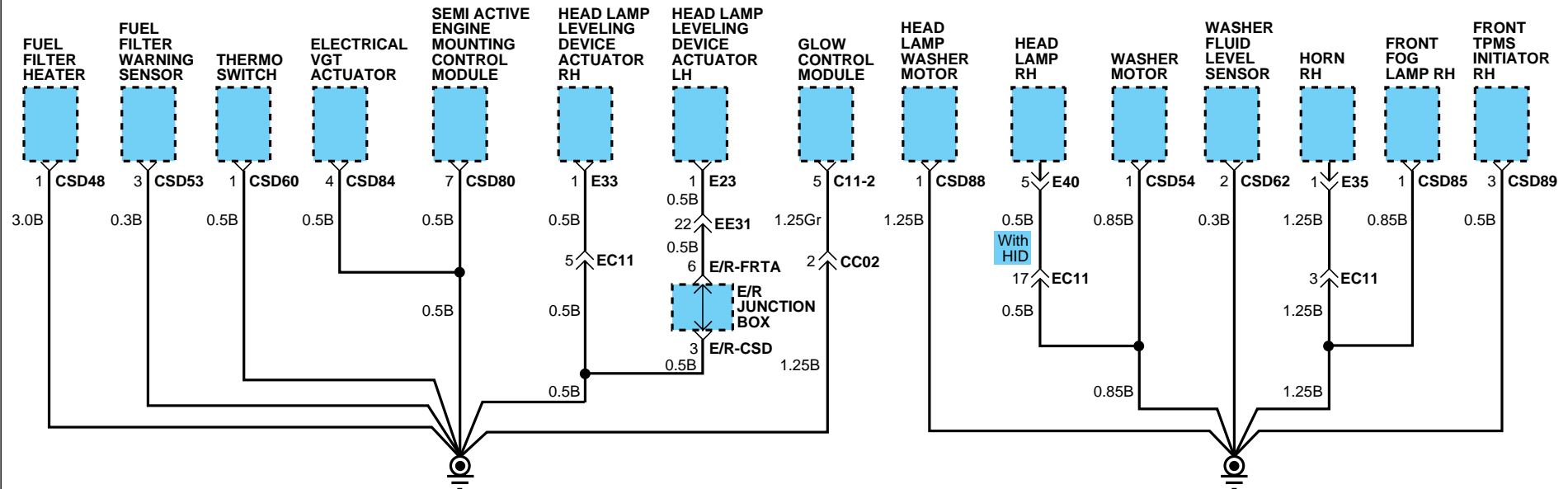

# GROUND DISTRIBUTION

## Ground Distribution (6)

SD130-6

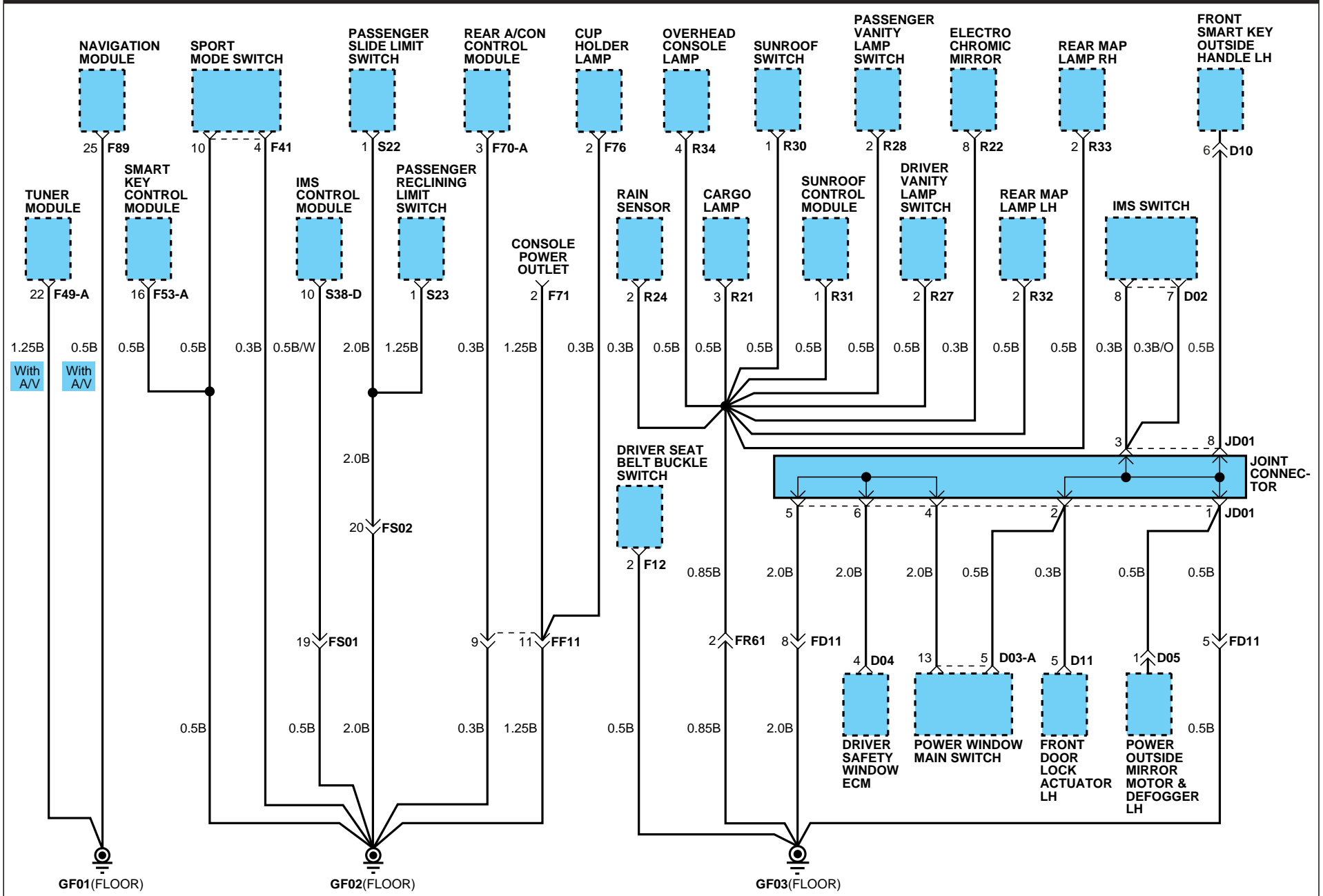



# GROUND DISTRIBUTION

## Ground Distribution (8)

SD130-8

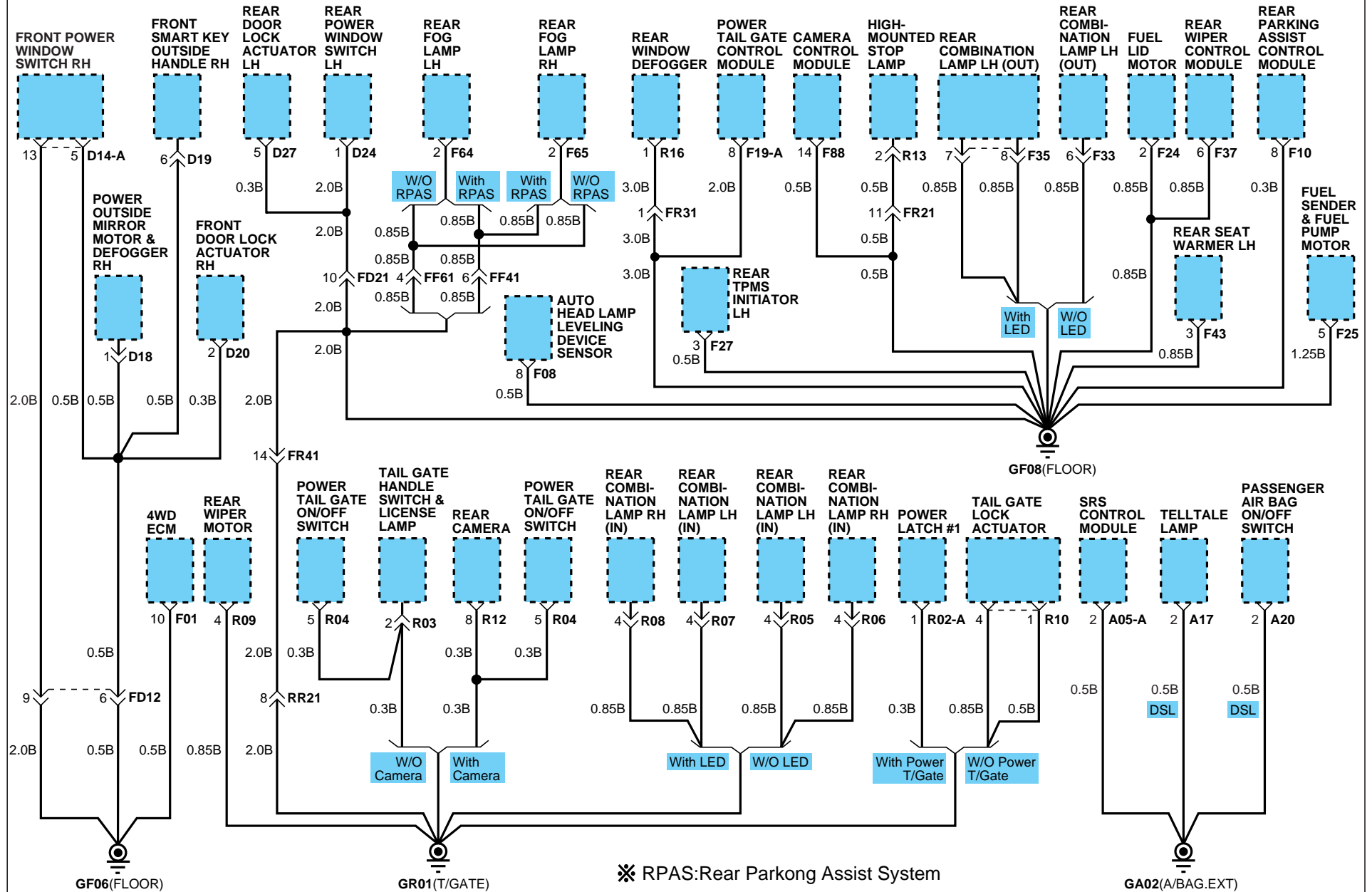





# DATA LINK DETAILS

## Data Link Details (2)

SD200-2

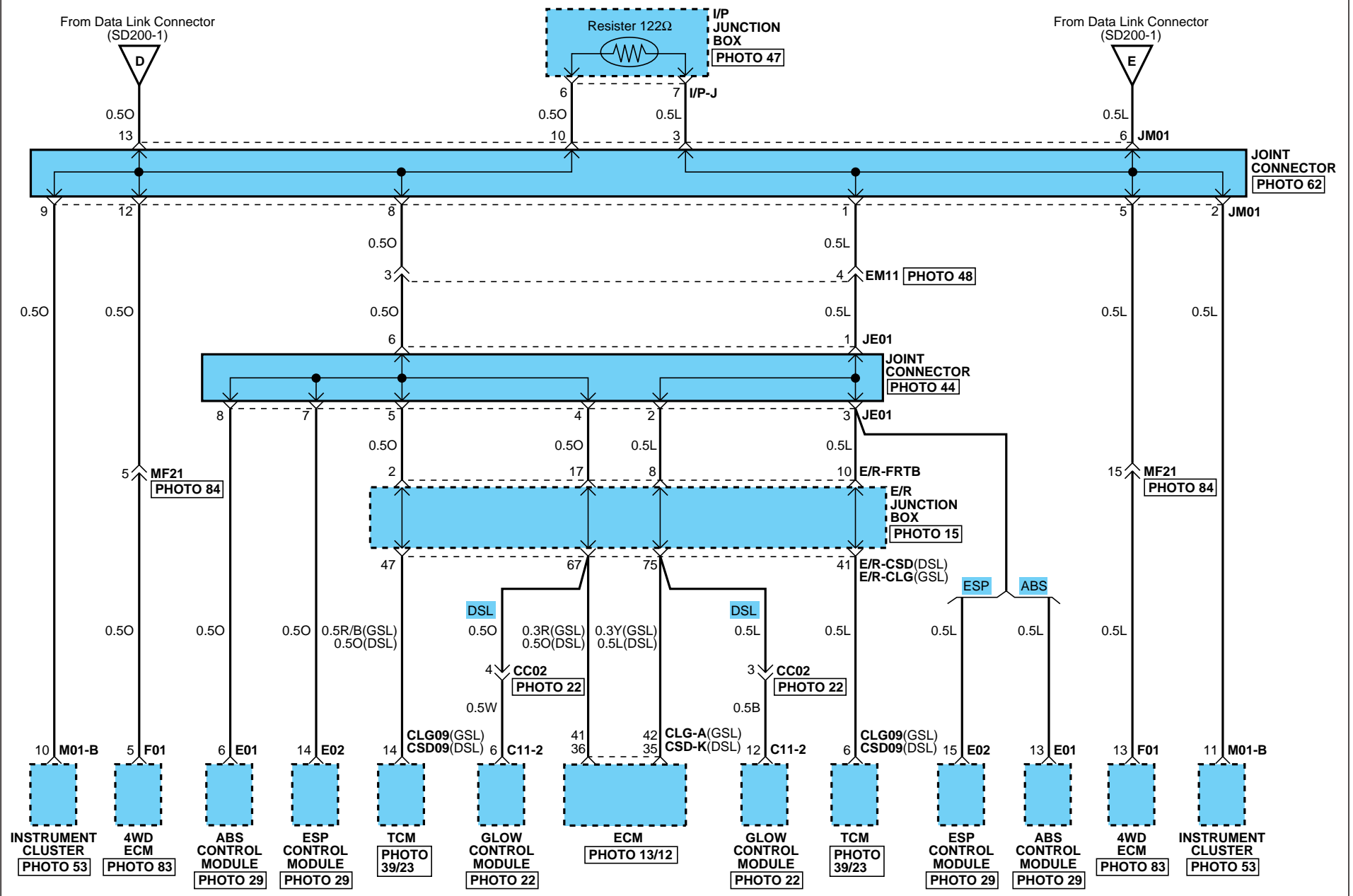

# DATA LINK DETAILS

## Data Link Details (3)

SD200-3

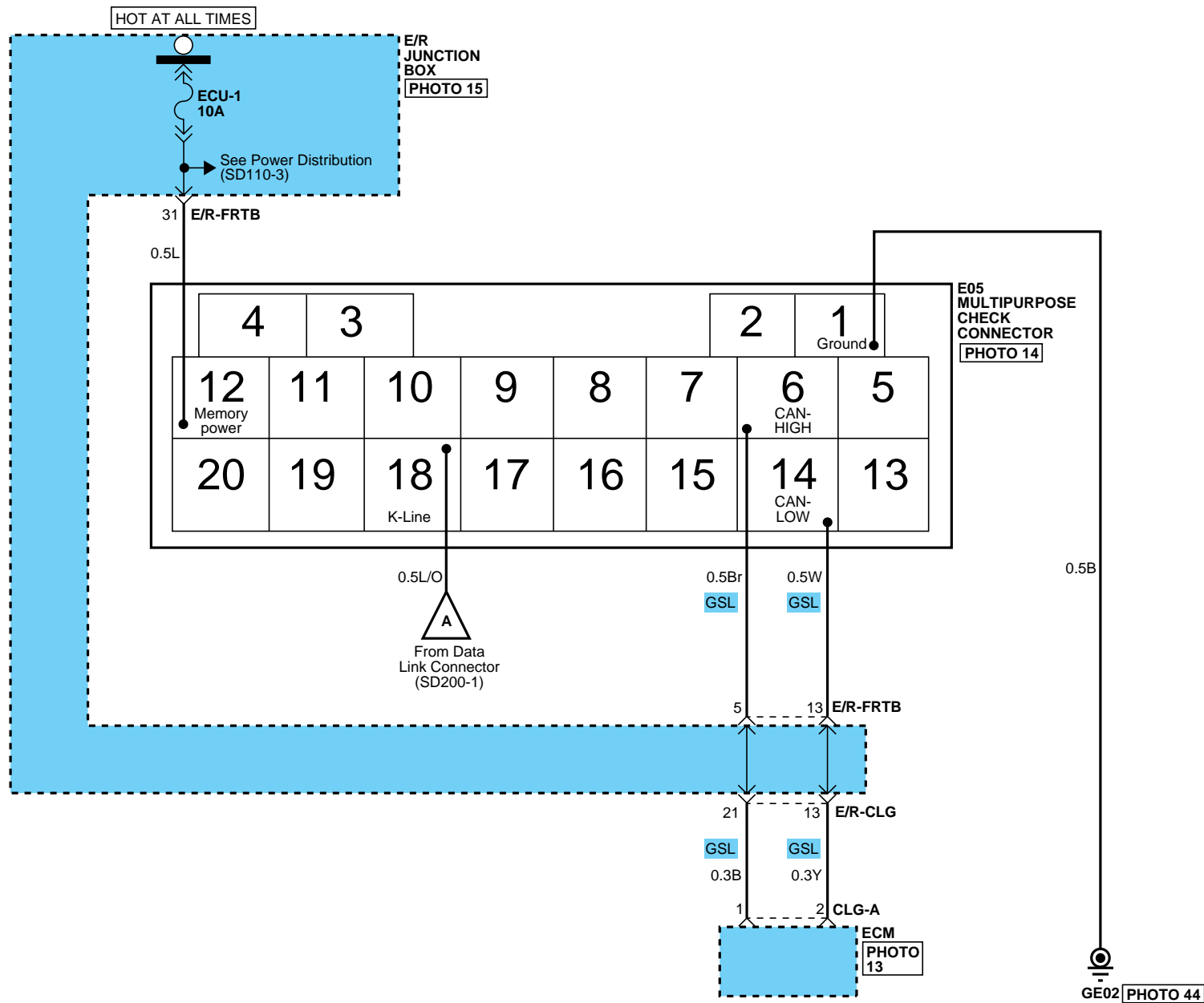

# DATA LINK DETAILS

## Data Link Details (4)

SD200-4

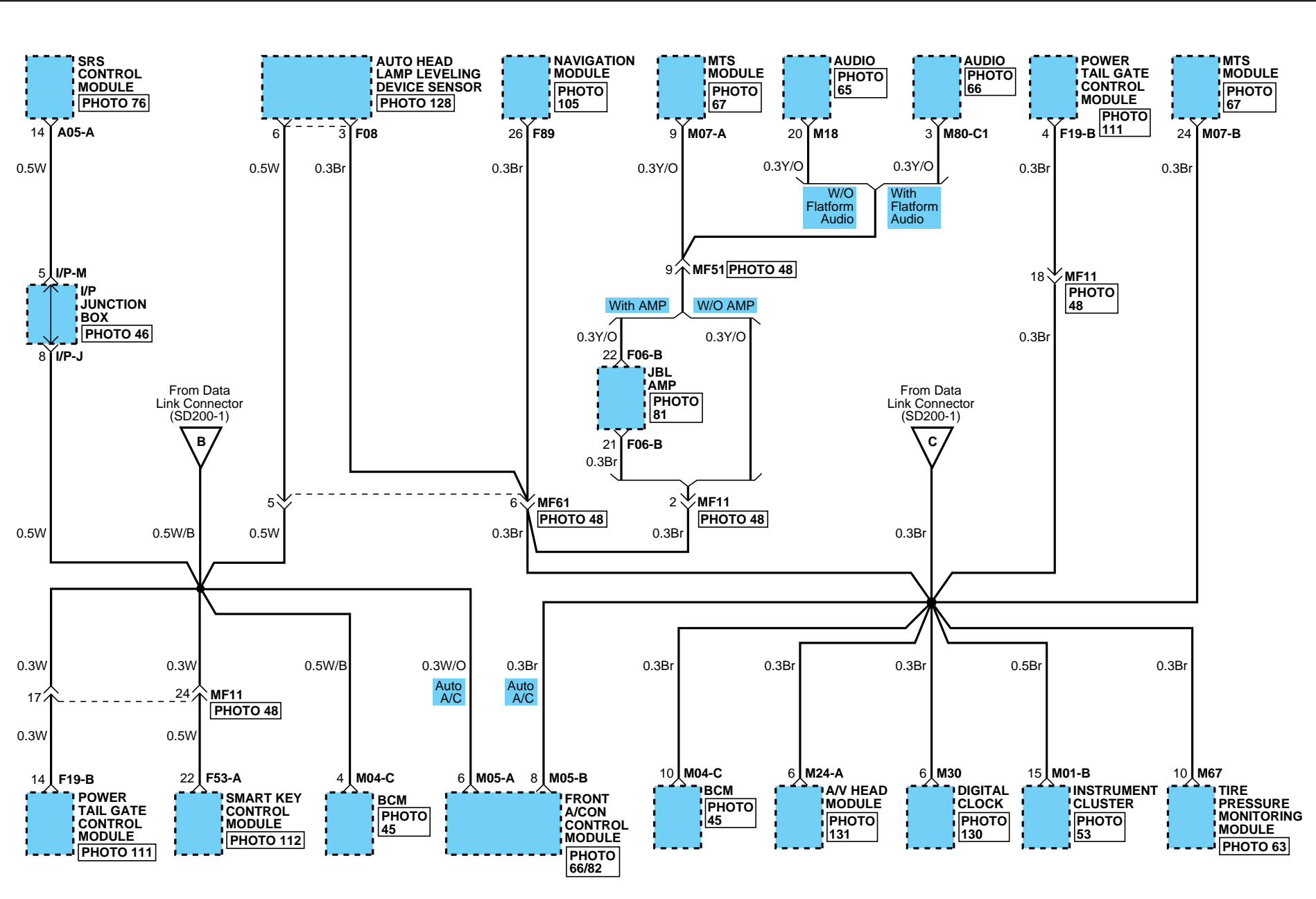



# DATA LINK DETAILS

## Data Link Details (6)

SD200-6

**F89**

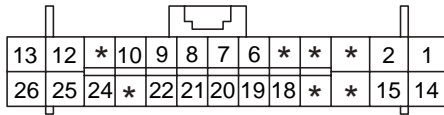

AMP\_0407\_26F\_W\_HD

**M01-B**

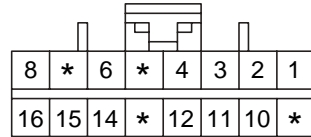

AMP\_040M2\_16F\_B

**M04-C**

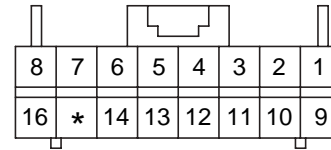

AMP\_0407\_16F\_W\_040

**M05-A**

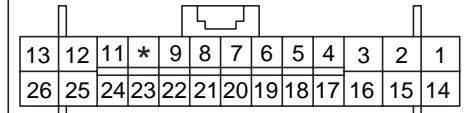

AMP\_0407\_26F\_W\_HD

**M05-B**

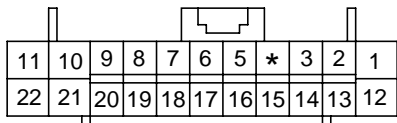

AMP\_0407\_22F\_W\_HD

**M07-A**

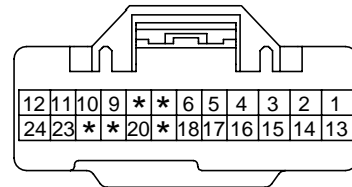

KET\_0409\_24F\_W

**M07-B**

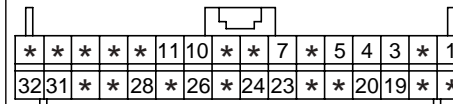

AMP\_025\_32F\_W

**M10**

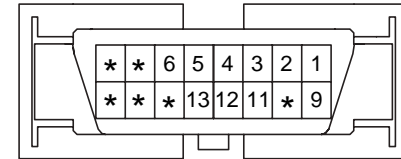

MLX\_OBDII\_16F\_B\_SIN

**M18**

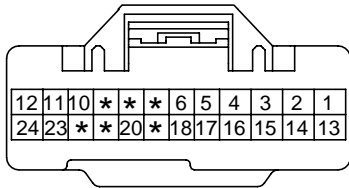

KET\_0409\_24F\_W

**M24-A**

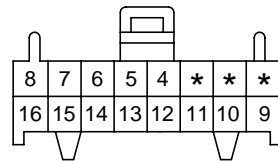

AMP\_DL1\_16F\_B

**M30**

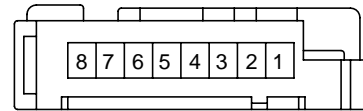

AMP\_MQS\_08F\_W

**M67**

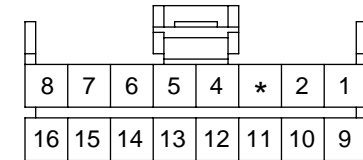

AMP\_040M1\_16F\_B

**M80-C1**

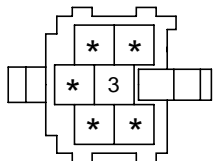

AMP\_AUDIO\_06F\_Y\_C1

**BLANK**

**BLANK**

**BLANK**

Semi Active Engine Mounting Control System (1)

SD218-1

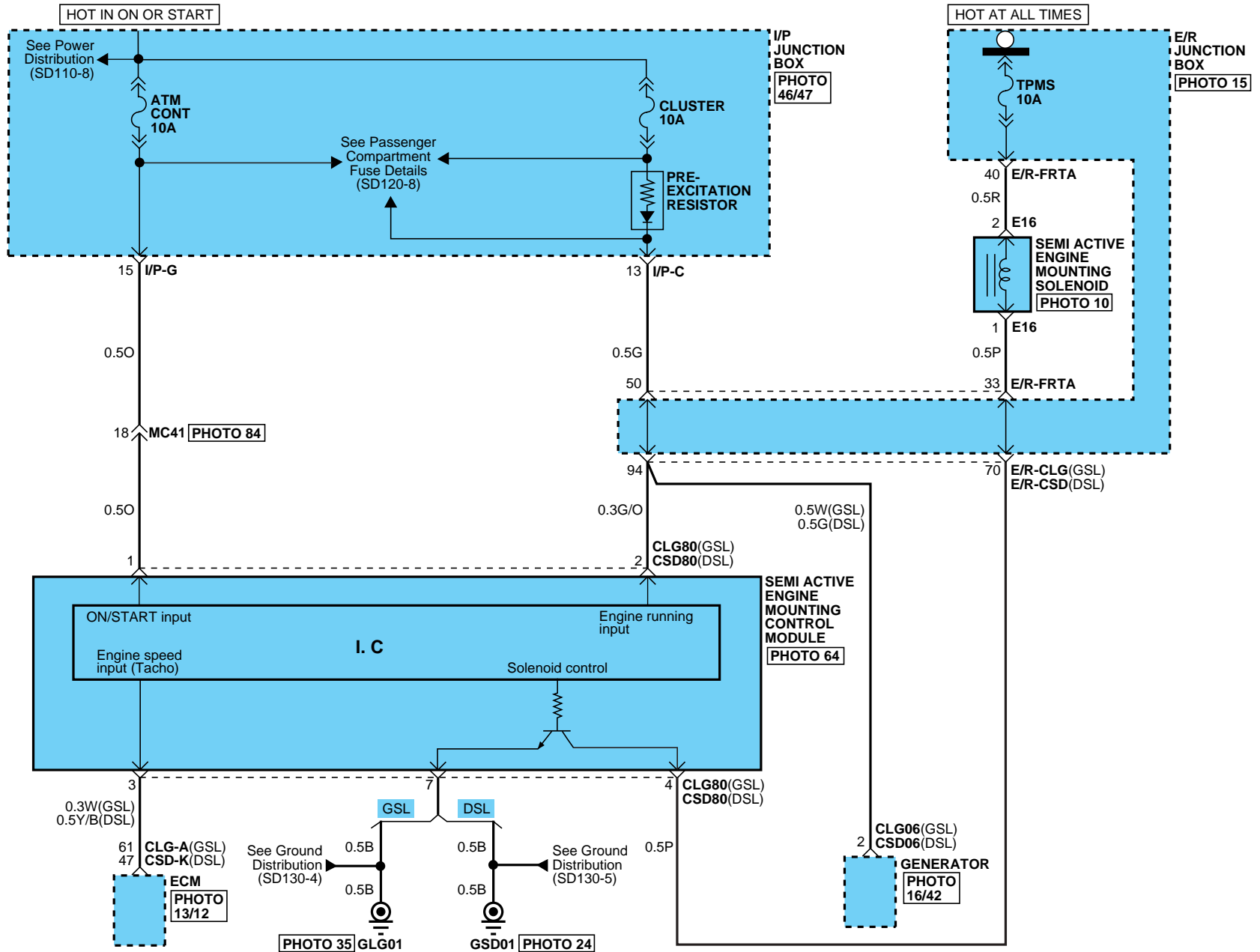

# SEMI ACTIVE ENGINE MOUNTING CONTROL SYSTEM

## Semi Active Engine Mounting Control System (2)

SD218-2

CLG-A

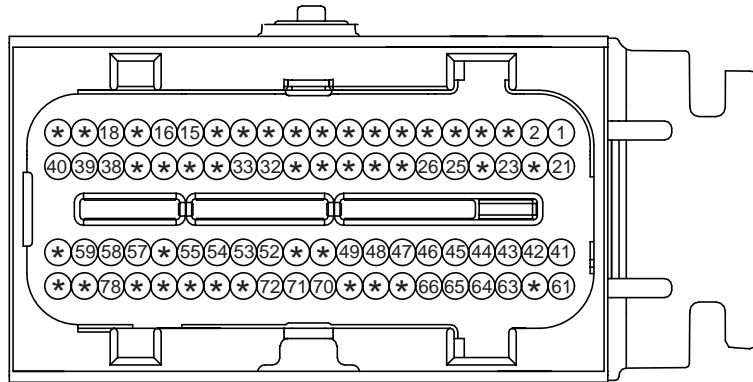

PKD\_ECU\_80F\_GR\_3

CSD-K

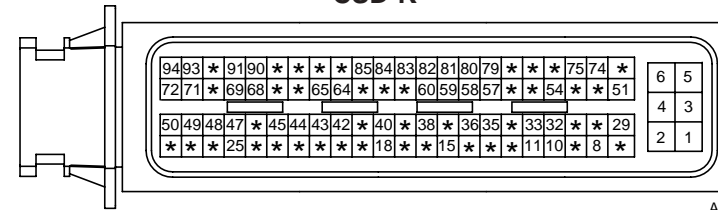

AMP\_ECU\_94F\_B

CLG06

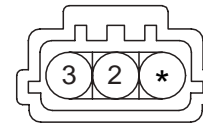

KET\_090IWP\_03F\_B

CLG80

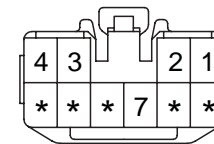

KET\_090II\_10F\_W

CSD06

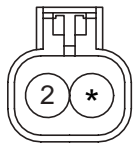

KET\_58X\_02F\_Gr

CSD80

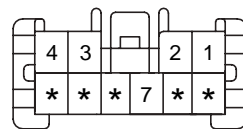

KET\_SDLII\_10F\_W

E16

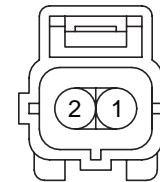

AMP\_EJWP\_02F\_B

BLANK



# COOLING SYSTEM

E85C0414

## Cooling System (1)

SD253-1

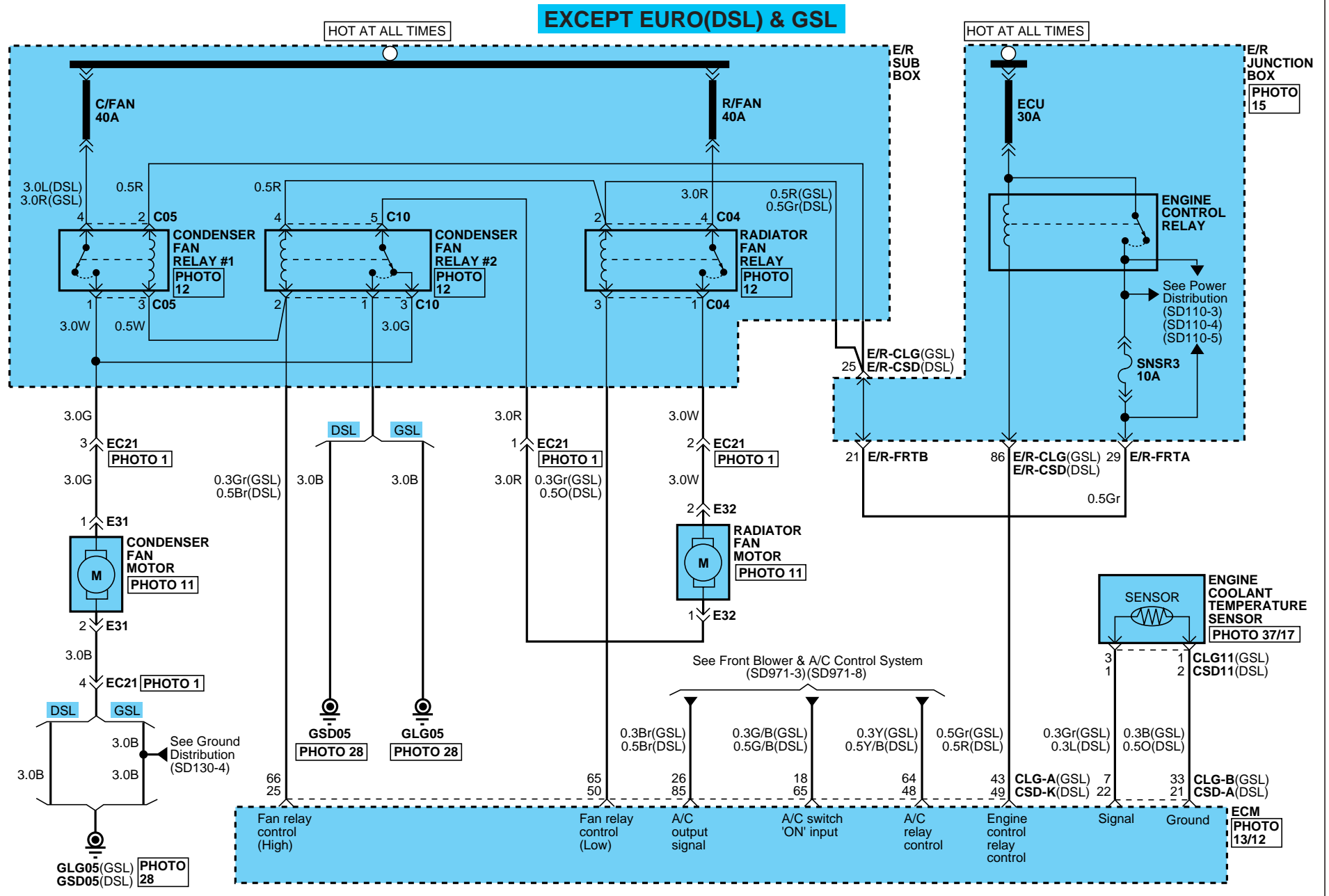



# COOLING SYSTEM

## Cooling System (3)

SD253-3

CLG-A

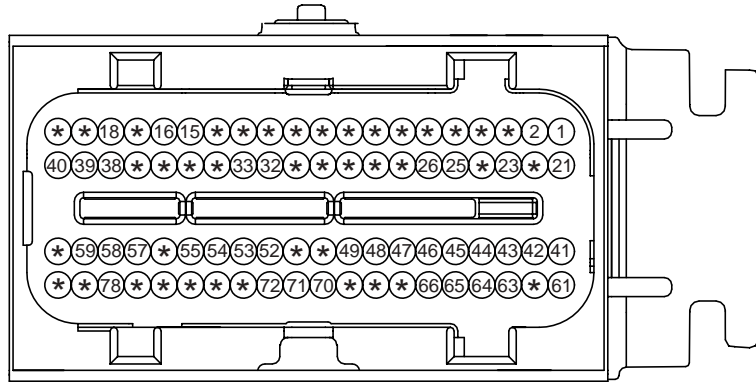

PKD\_ECU\_80F\_GR\_3

CLG-B

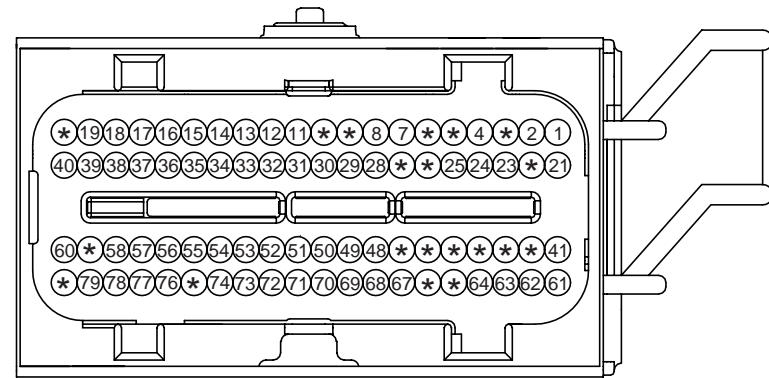

PKD\_ECU\_80F\_B\_4

CSD-A

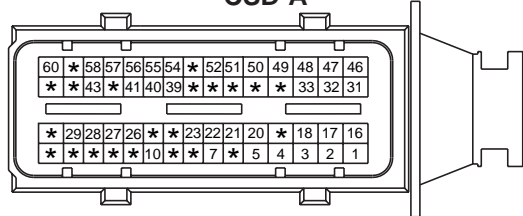

AMP\_ECU\_60F\_B

CSD-K

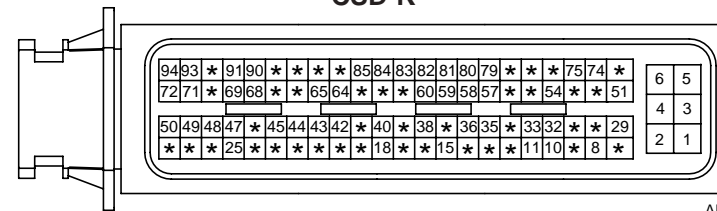

AMP\_ECU\_94F\_B

CLG11

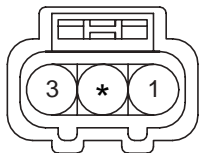

KUM\_62Z\_03F\_B\_WTS

CSD11

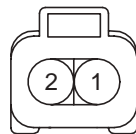

AMP\_090WP\_02F\_B

C04

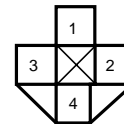

CR04F067

C05

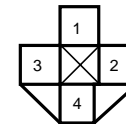

CR04F067

C10

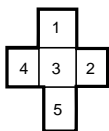

CR05F029

E31

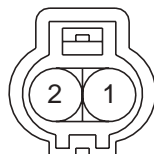

AMP\_187IWP\_02F\_B

E32

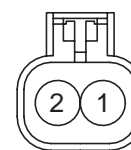

KET\_58X\_02F\_B

E41



KET\_31211WP\_02F\_B

# COOLING SYSTEM

Cooling System (4)

SD253-4

E42



KET\_31211WP\_02F\_B

BLANK

BLANK

BLANK



# MFI CONTROL SYSTEM

## MFI Control System (G6DA-GSL 3.8L) (2)

SD313-2

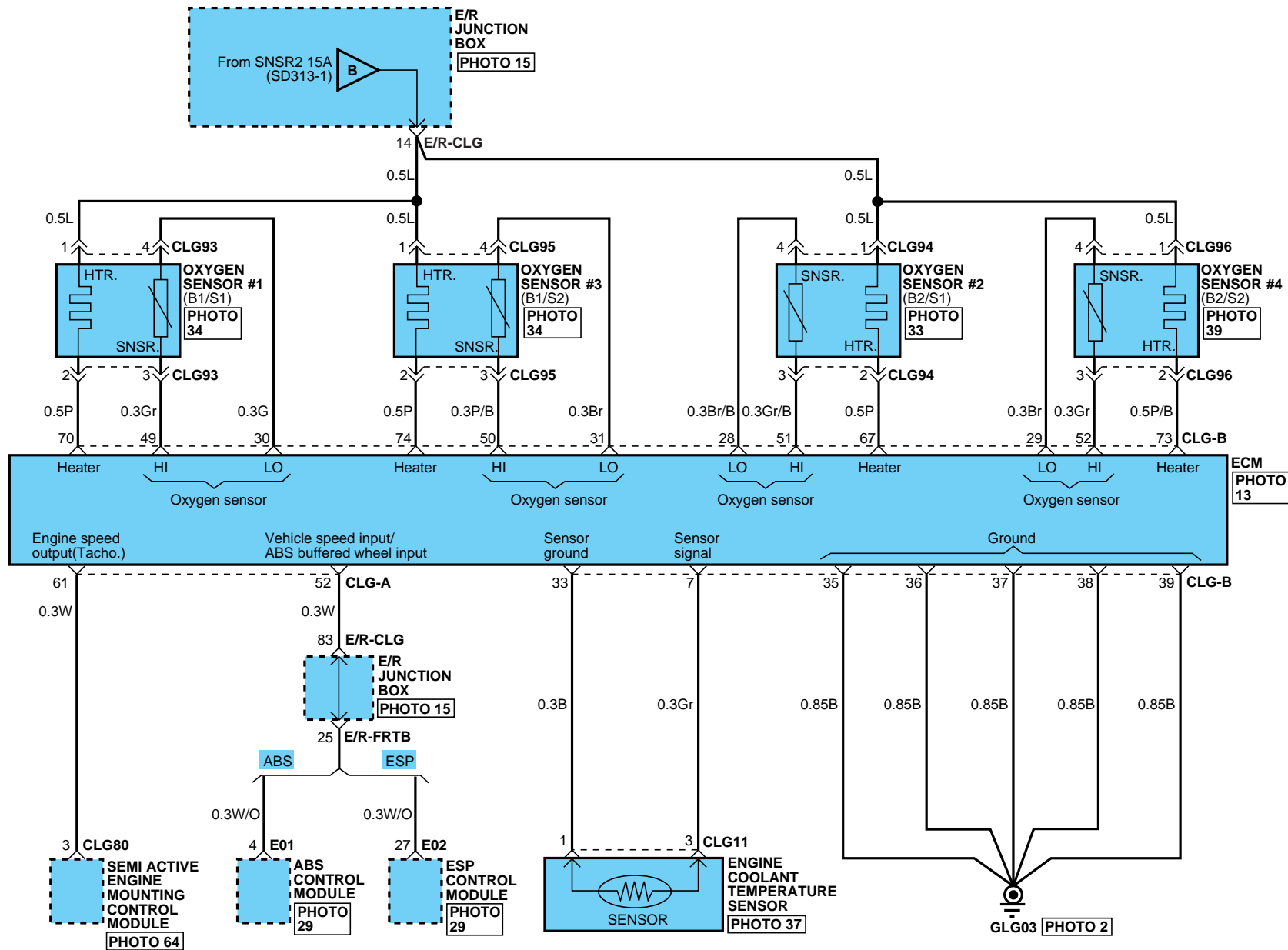

# MFI CONTROL SYSTEM

## MFI Control System (G6DA-GSL 3.8L) (3)

SD313-3

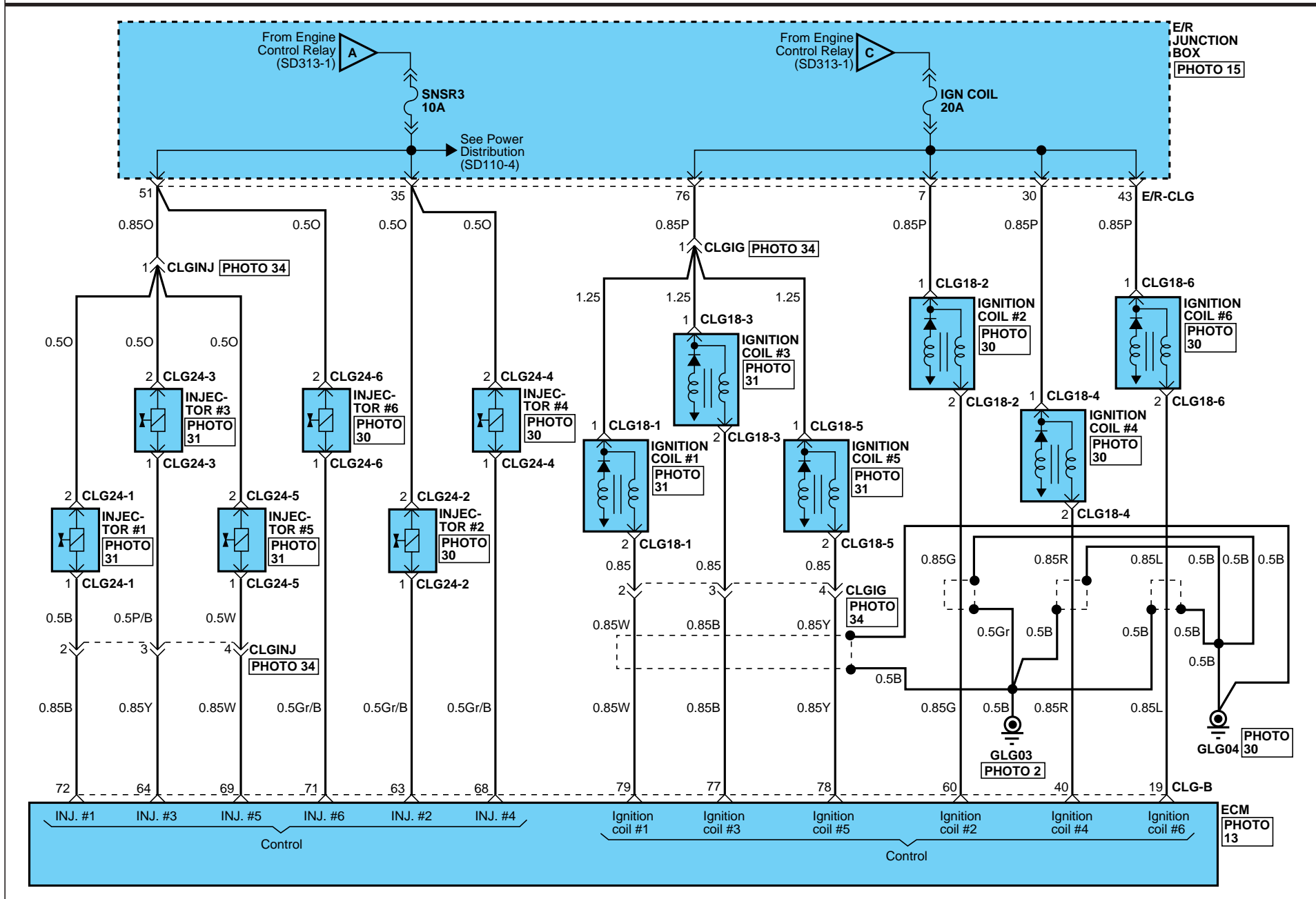

# MFI CONTROL SYSTEM

## MFI Control System (G6DA-GSL 3.8L) (4)

SD313-4

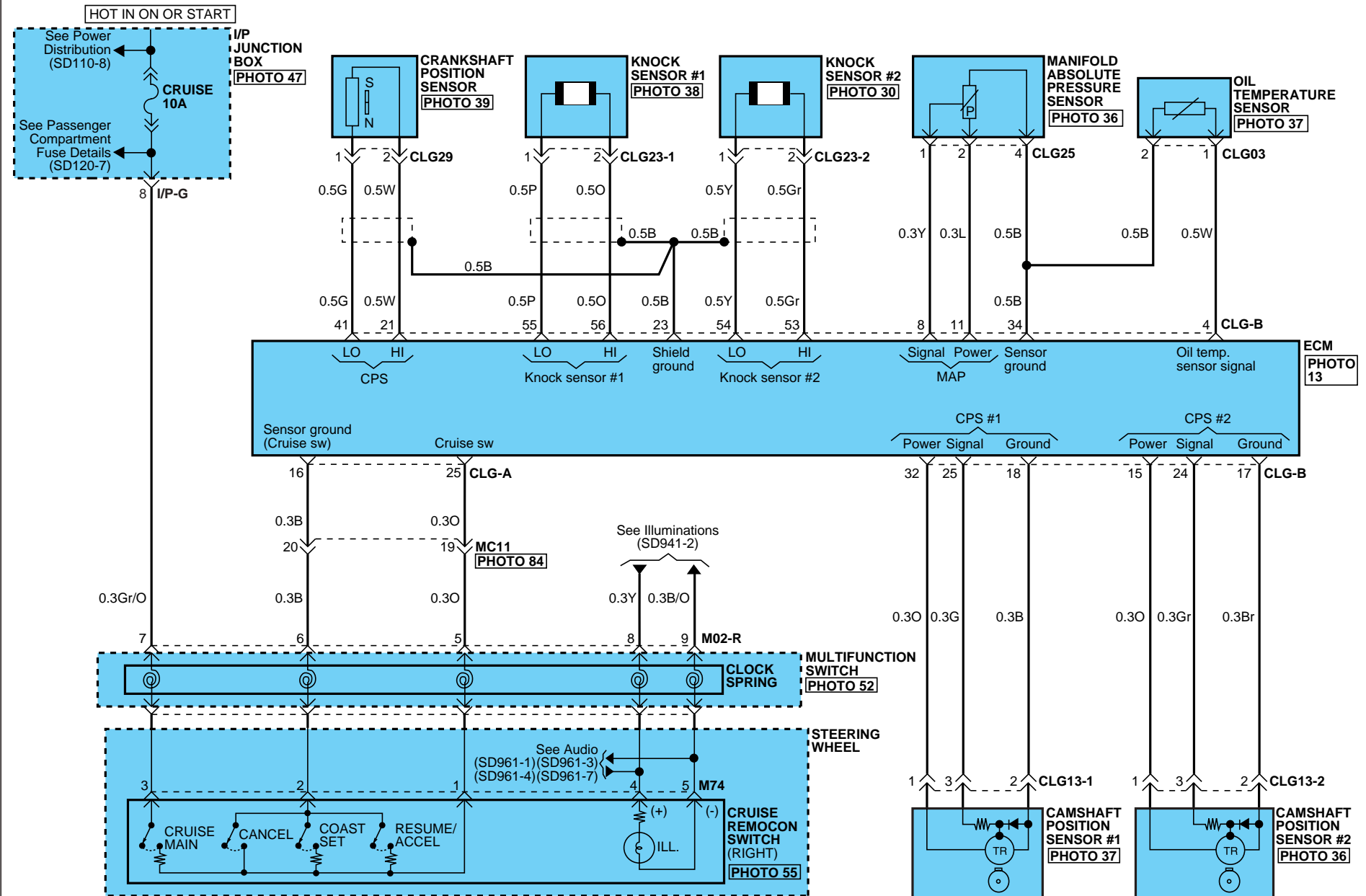



# MFI CONTROL SYSTEM

## MFI Control System (G6DA-GSL 3.8L) (5)

SD313-5

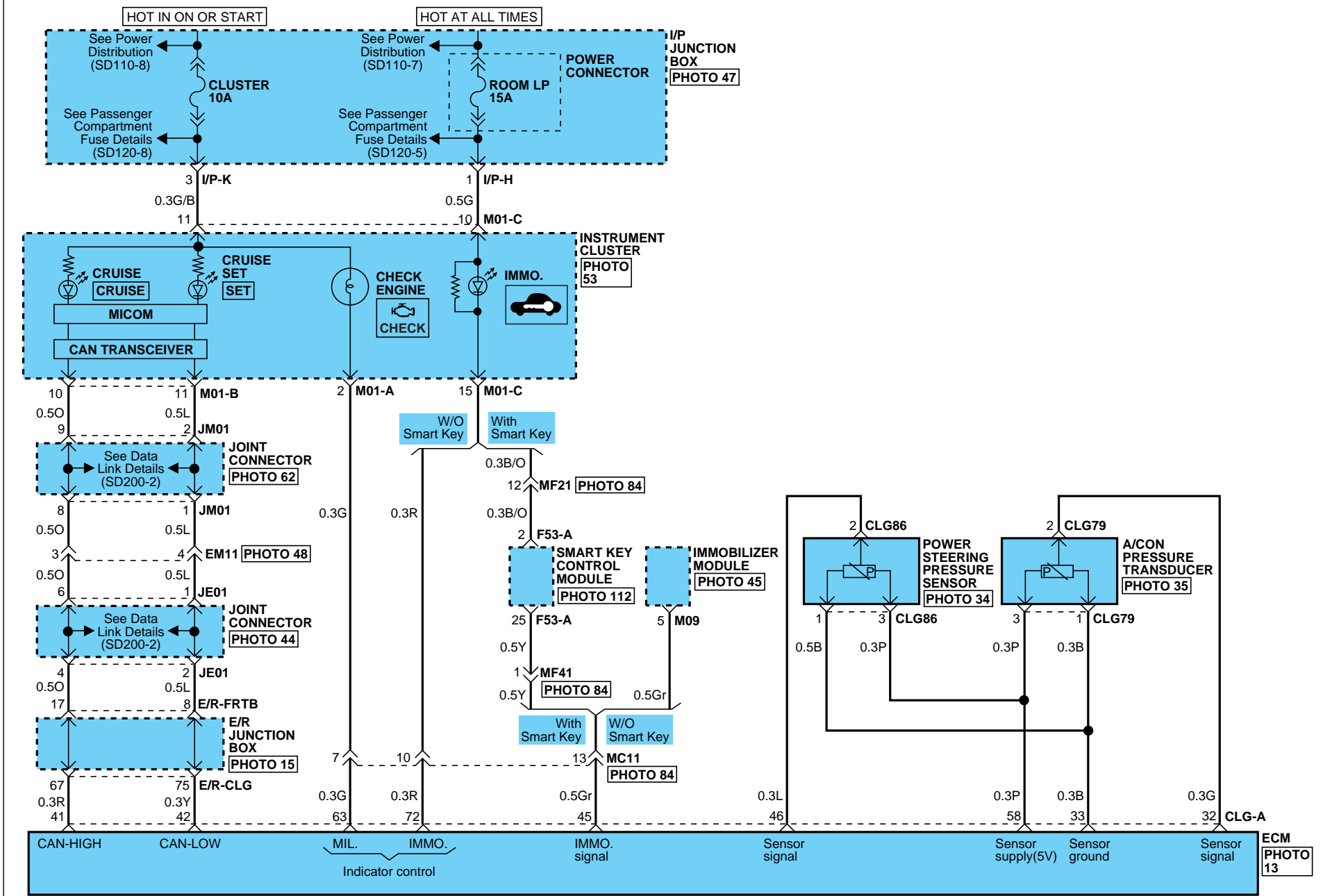



# MFI CONTROL SYSTEM

## MFI Control System (G6DA-GSL 3.8L) (7)

SD313-7

**CLG-A**

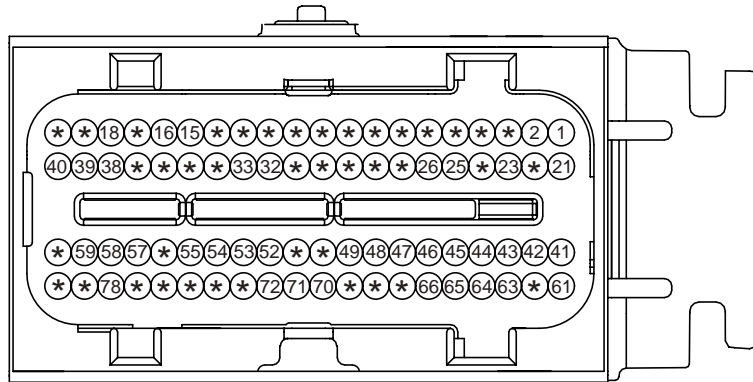

PKD\_ECU\_80F\_GR\_3

**CLG-B**

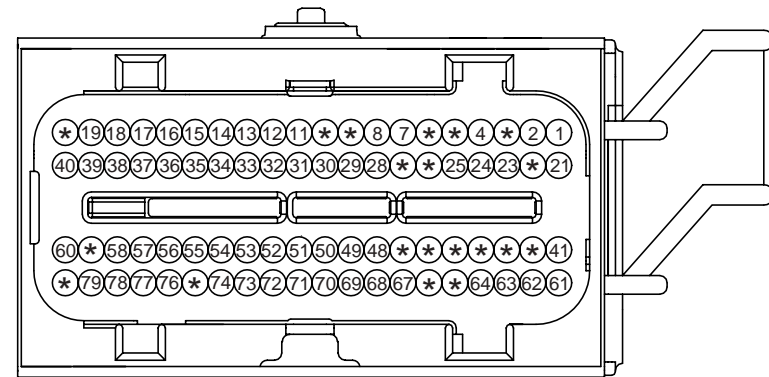

PKD\_ECU\_80F\_B\_4

**CLG03**

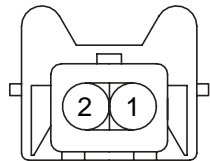

AMP\_JPT\_02F\_B\_CLIP

**CLG11**

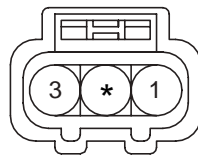

KUM\_62Z\_03F\_B\_WTS

**CLG13-1,2**

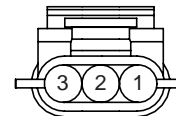

PKD\_150WP\_03F\_B\_L

**CLG18-1,2,3,4,5,6**



KET\_090IWP\_02F\_Gr\_VER

**CLG21**

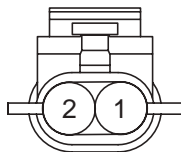

PKD\_MP150\_02F\_B

**CLG23-1,2**

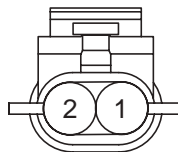

PKD\_MP150\_02F\_GR

**CLG24-1,2,3,4,5,6**

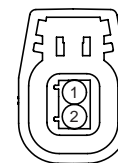

PKD\_GT150\_02F\_B

**CLG25**

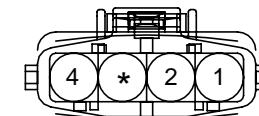

AMP\_JPT\_04F\_B\_BOSCH

**CLG27**

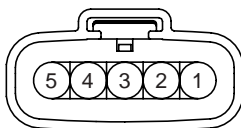

PKD\_GT150\_05F\_B

**CLG29**

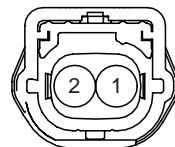

BSH\_SENSOR\_02F\_B

**CLG44**

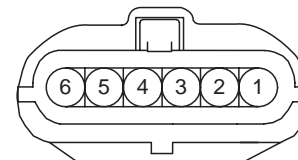

AMP\_070WP\_06F\_B

**CLG58**

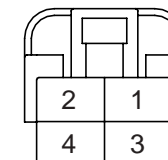



KET\_250DL\_04F\_W

# MFI CONTROL SYSTEM

## MFI Control System (G6DA-GSL 3.8L) (8)

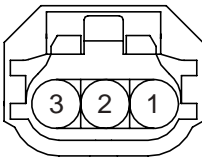
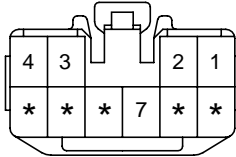
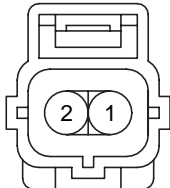
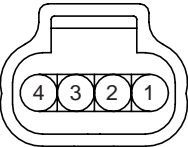
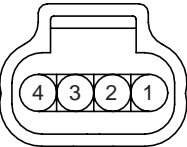
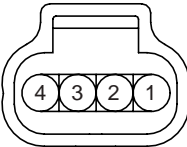
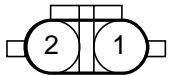
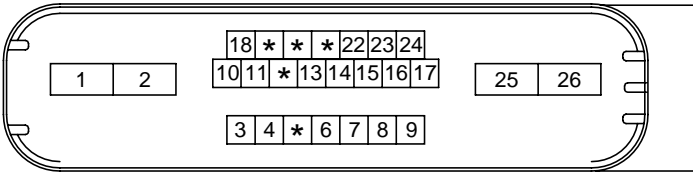
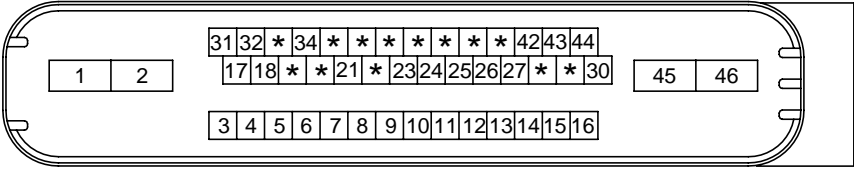
SD313-8

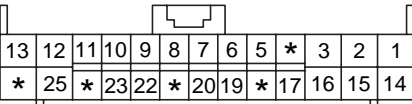
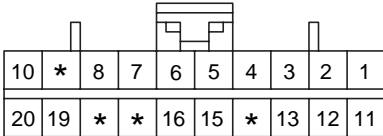
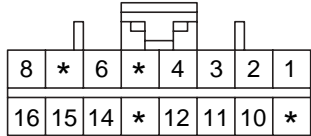
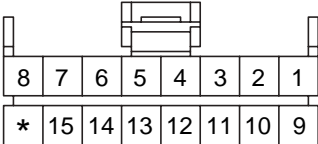
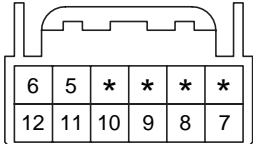
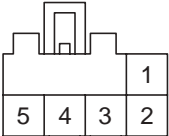
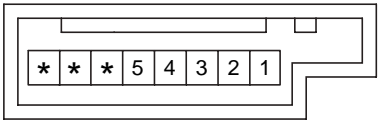
<p><b>CLG65</b></p>  <p>PKD_GT150_08F_B</p>	<p><b>CLG79/CLG86</b></p>  <p>KET_040_WP_03F_B</p>	<p><b>CLG80</b></p>  <p>KET_090I1_10F_W</p>	<p><b>CLG87</b></p>  <p>AMP_EJWP_02F_B</p>
<p><b>CLG93</b></p>  <p>PKD_GT150_04F_Gr</p>	<p><b>CLG94/CLG95</b></p>  <p>PKD_GT150_04F_B</p>	<p><b>CLG96</b></p>  <p>PKD_GT150_04F_Gr</p>	<p><b>CLG98-1,2</b></p>  <p>CR02F134</p>
<p><b>E01</b></p>  <p>FC1_ABS_26F_B</p>		<p><b>E02</b></p>  <p>FC1_ESP_46F_B</p>	
<p><b>F25</b></p>  <p>KET_090IWP_05F_Gr_2</p>	<p><b>F53-A</b></p>  <p>AMP_0407_26F_W_HD</p>	<p><b>M01-A</b></p>  <p>AMP_040M2_20F_B</p>	<p><b>M01-B</b></p>  <p>AMP_040M2_16F_B</p>
<p><b>M01-C</b></p>  <p>AMP_040M1_16F_B</p>	<p><b>M02-R</b></p>  <p>AMP_025_12F_W</p>	<p><b>M09</b></p>  <p>KUM_CDR_05F_W</p>	<p><b>M74</b></p>  <p>AMP_1743386-1</p>

# MFI CONTROL SYSTEM

## MFI Control System (D6EA DSL 3.0L) (1)

SD313-9

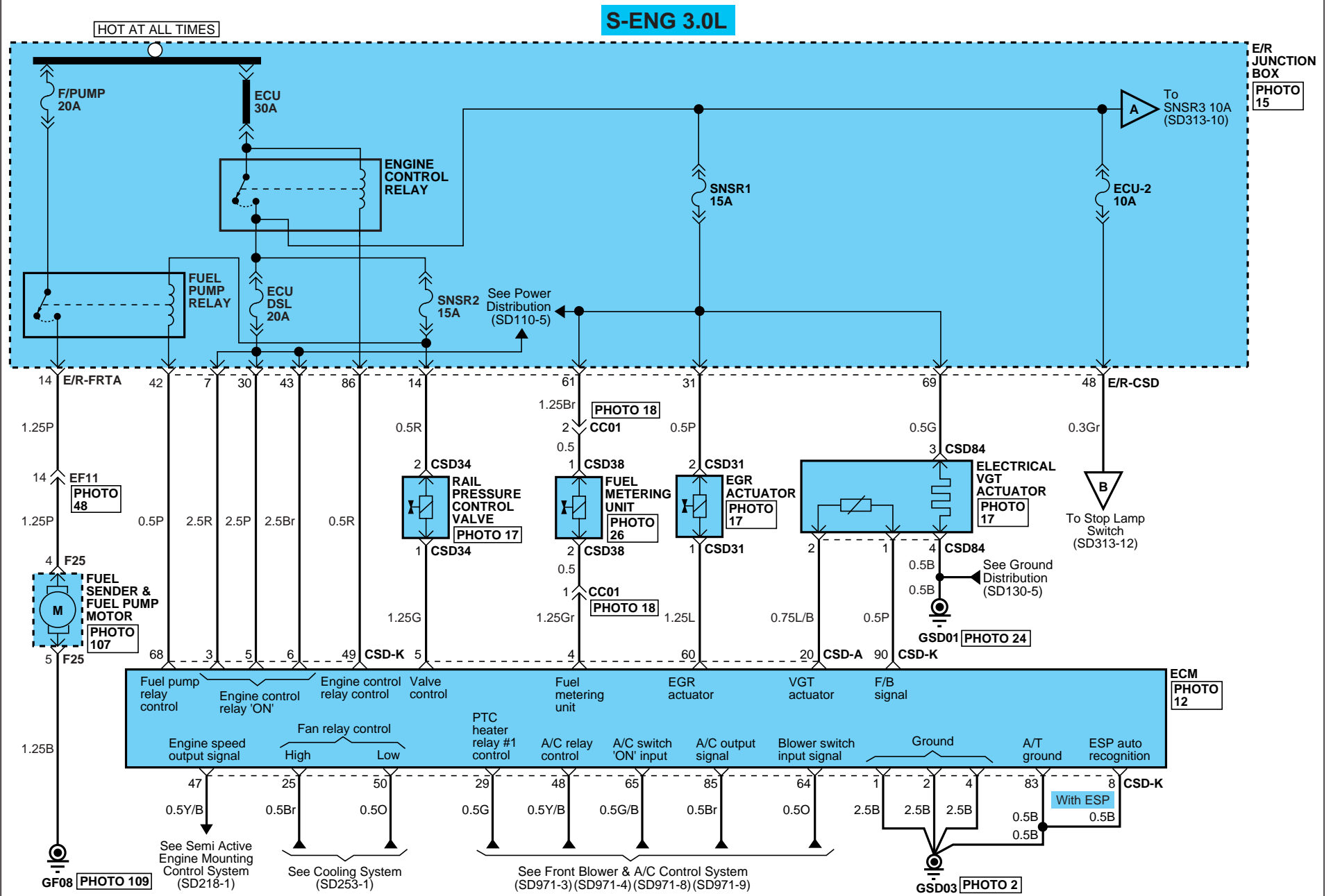

# MFI CONTROL SYSTEM

## MFI Control System (D6EA-DSL 3.0L) (2)

SD313-10

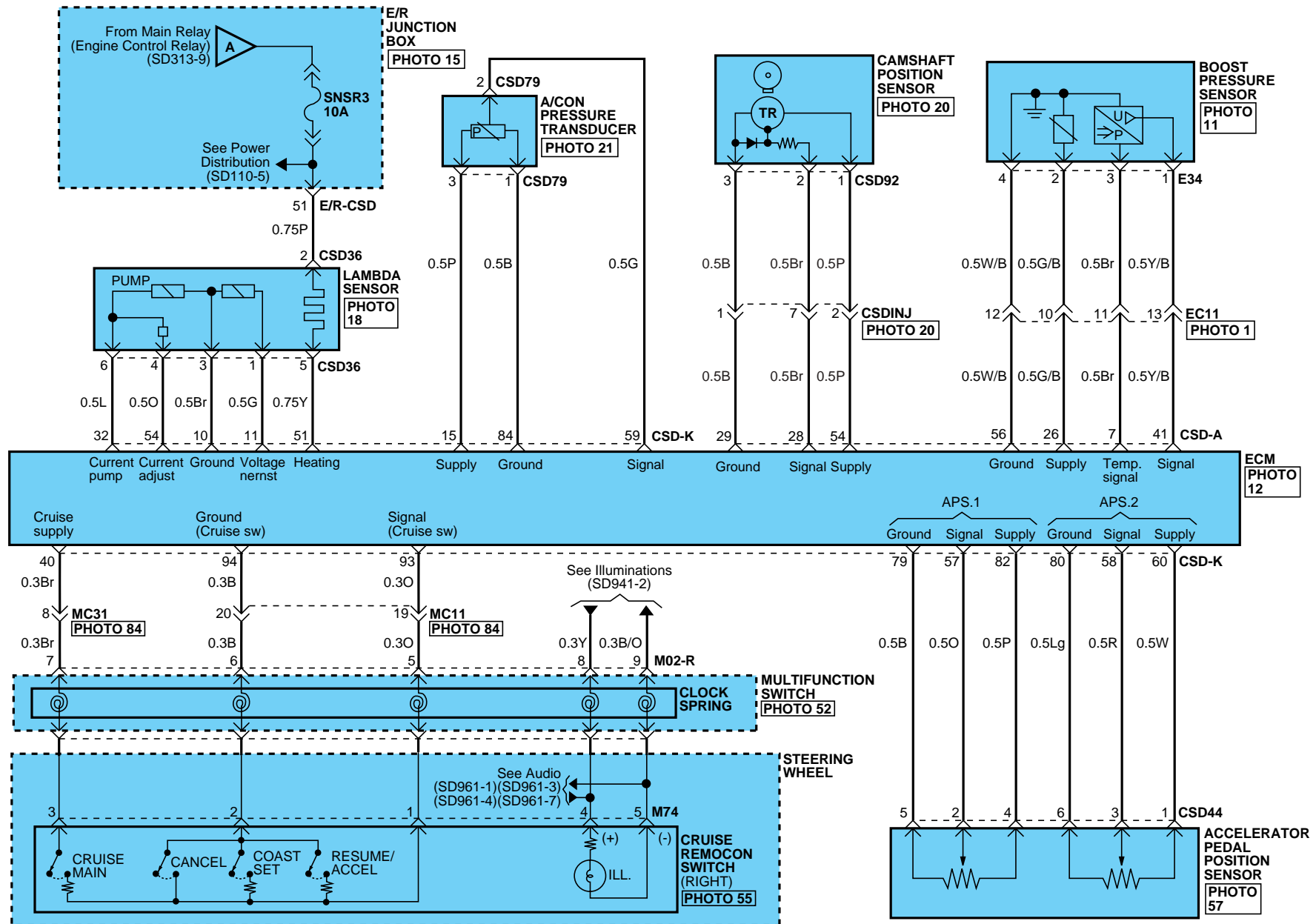



# MFI CONTROL SYSTEM

## MFI Control System (D6EA-DSL 3.0L) (4)

SD313-12

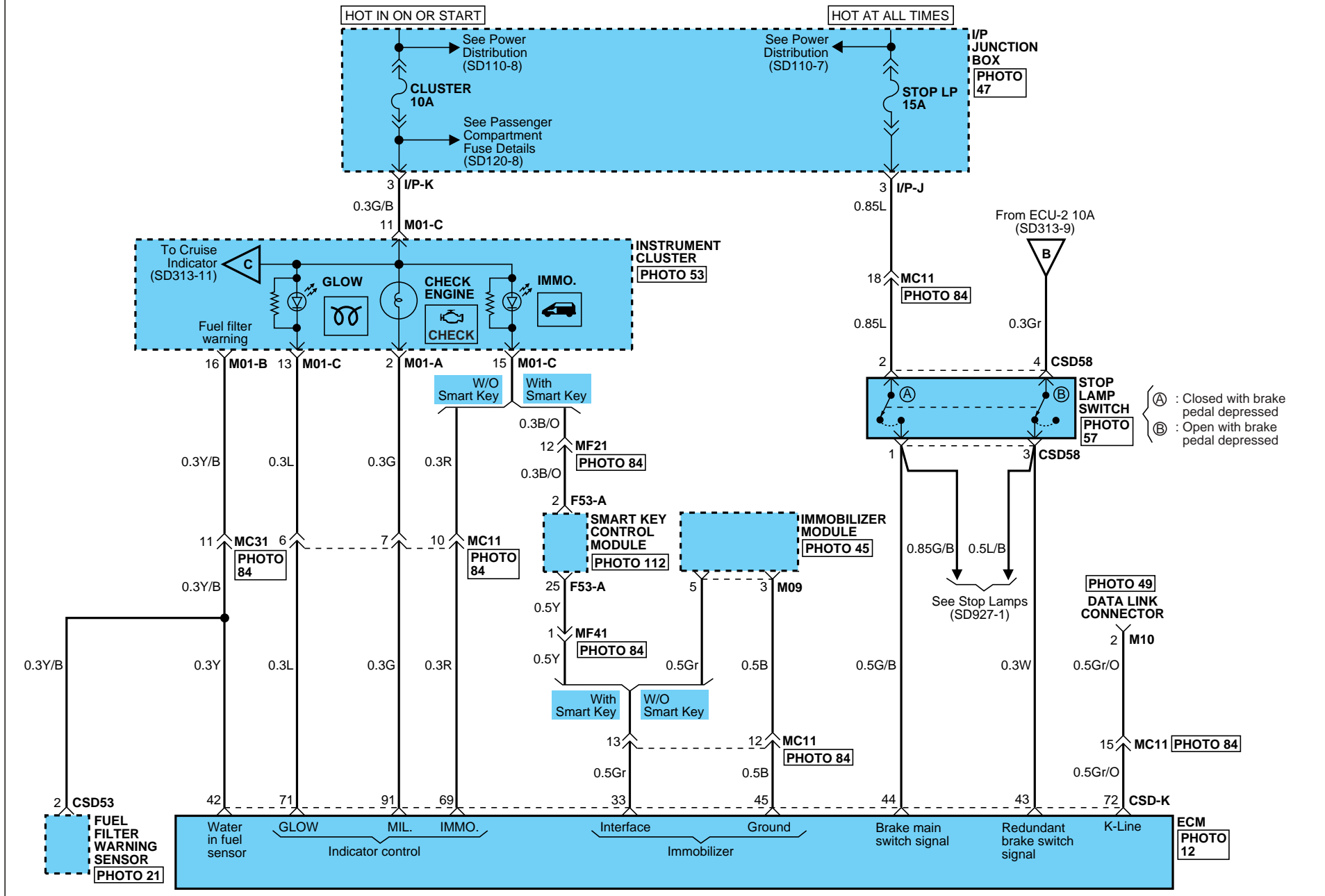



# MFI CONTROL SYSTEM

## MFI Control System (D6EA-DSL 3.0L) (5)



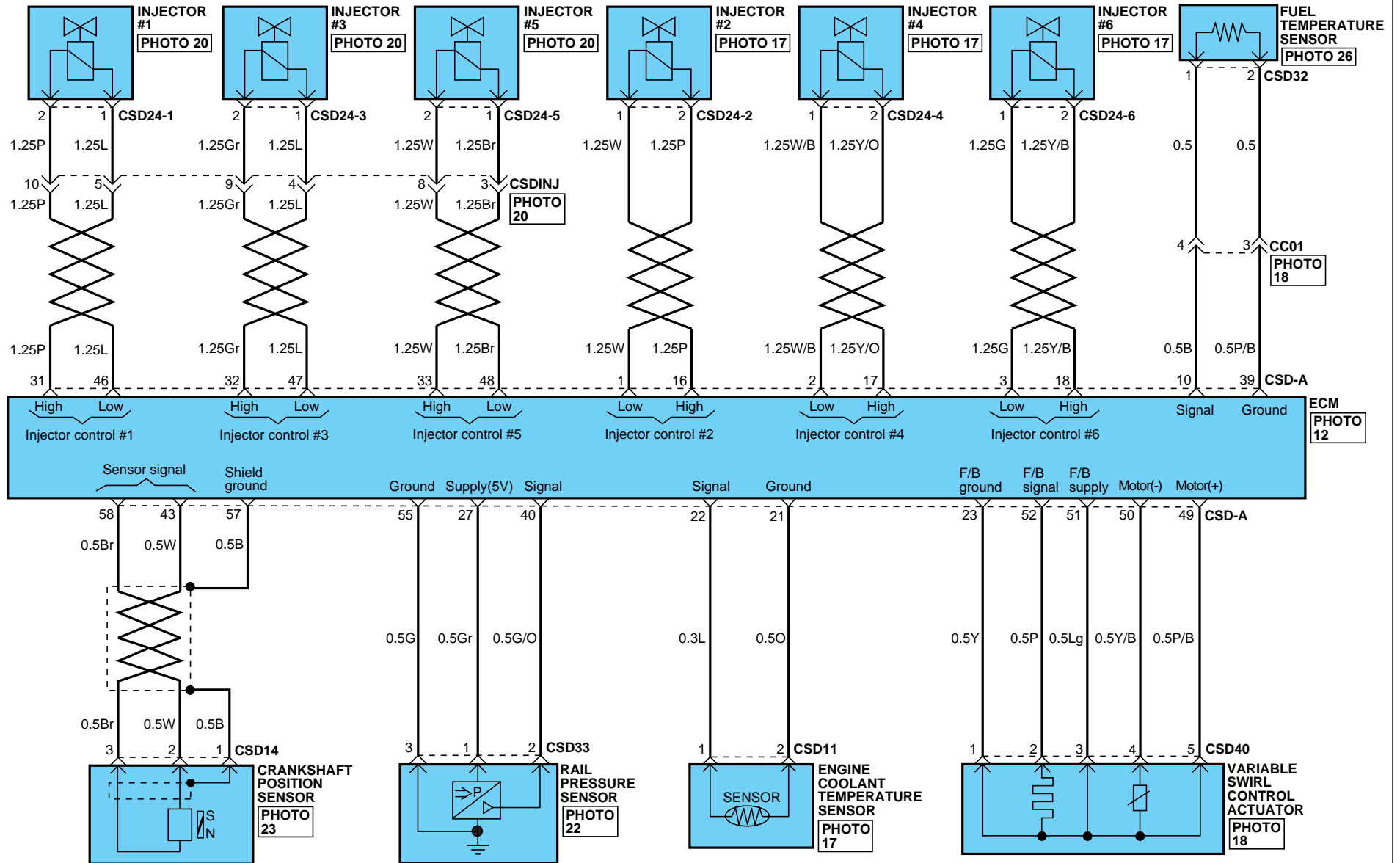

SD313-13

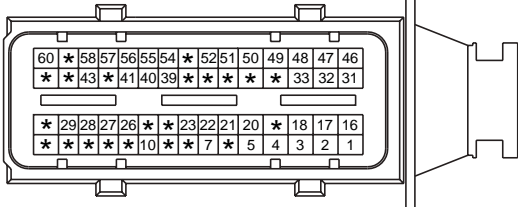
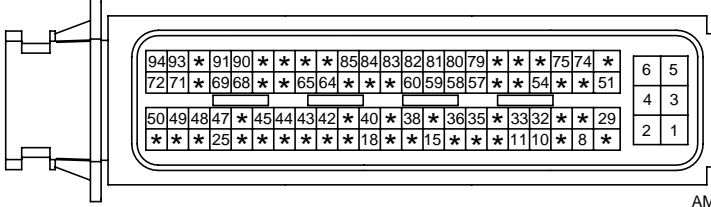
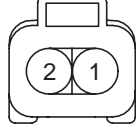
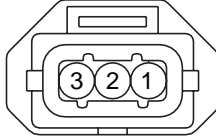
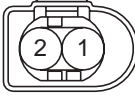
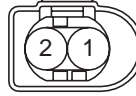
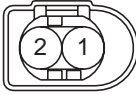

# MFI CONTROL SYSTEM

## MFI Control System (D6EA-DSL 3.0L) (6)

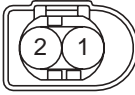
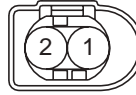
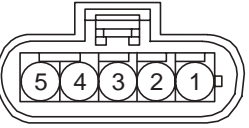
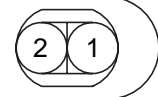
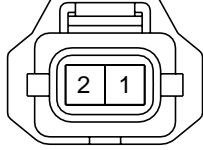

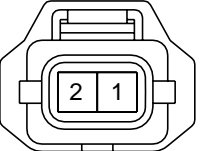
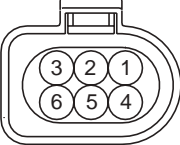
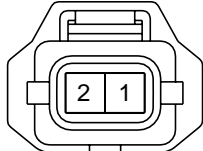
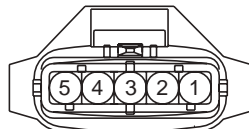



SD313-14

<p style="text-align: center;"><b>CSD-A</b></p>  <p style="text-align: right;">AMP_ECU_60F_B</p>		<p style="text-align: center;"><b>CSD-K</b></p>  <p style="text-align: right;">AMP_ECU_94F_B</p>	
<p style="text-align: center;"><b>CSD11</b></p>  <p style="text-align: right;">AMP_090WP_02F_B</p>	<p style="text-align: center;"><b>CSD14</b></p>  <p style="text-align: right;">AMP_SFT_03F_B</p>	<p style="text-align: center;"><b>CSD24-1</b></p>  <p style="text-align: right;">AMP_INJ_02F_B</p>	<p style="text-align: center;"><b>CSD24-2</b></p>  <p style="text-align: right;">AMP_INJ_02F_B</p>
<p style="text-align: center;"><b>CSD24-3</b></p>  <p style="text-align: right;">AMP_INJ_02F_B</p>	<p style="text-align: center;"><b>CSD24-4</b></p>  <p style="text-align: right;">AMP_INJ_02F_B</p>	<p style="text-align: center;"><b>CSD24-5</b></p>  <p style="text-align: right;">AMP_INJ_02F_B</p>	<p style="text-align: center;"><b>CSD24-6</b></p>  <p style="text-align: right;">AMP_INJ_02F_B</p>
<p style="text-align: center;"><b>CSD27</b></p>  <p style="text-align: right;">HSM_SENSOR_05F_B</p>	<p style="text-align: center;"><b>CSD31</b></p>  <p style="text-align: right;">KST_SENSOR_02F_B_NF</p>	<p style="text-align: center;"><b>CSD32</b></p>  <p style="text-align: right;">AMP_2.8WP_02F_B</p>	<p style="text-align: center;"><b>CSD33</b></p>  <p style="text-align: right;">AMP_090_03F_B_WP</p>
<p style="text-align: center;"><b>CSD34</b></p>  <p style="text-align: right;">AMP_2.8WP_02F_B</p>	<p style="text-align: center;"><b>CSD36</b></p>  <p style="text-align: right;">BSH_SENSOR_06F_B_NF</p>	<p style="text-align: center;"><b>CSD38</b></p>  <p style="text-align: right;">AMP_2.8WP_02F_B</p>	<p style="text-align: center;"><b>CSD40</b></p>  <p style="text-align: right;">AMP_JPT_05F_B_SFT</p>

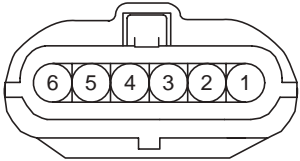
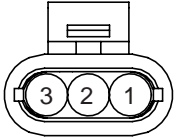
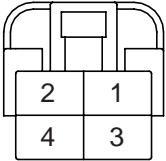
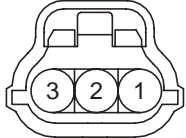
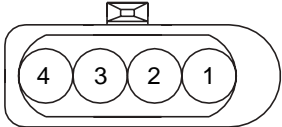
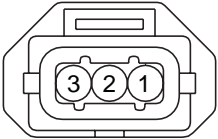
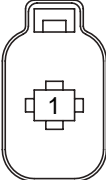
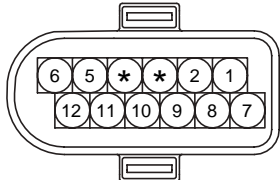
# MFI CONTROL SYSTEM

## MFI Control System (D6EA-DSL 3.0L) (7)

SD313-15

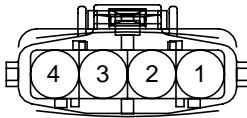
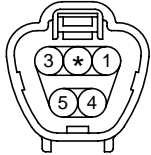
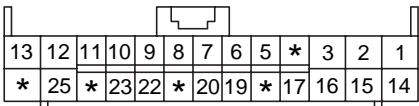
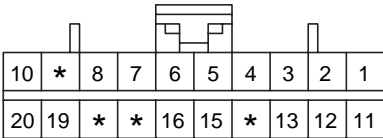
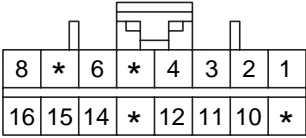
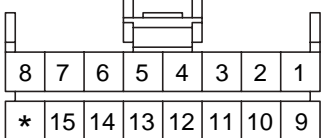
<p><b>CSD44</b></p>  <p>AMP_070WP_06F_B</p>	<p><b>CSD53</b></p>  <p>AMP_1.5WP_03F_B</p>	<p><b>CSD58</b></p>  <p>KET_250DL_04F_W</p>	<p><b>CSD79</b></p>  <p>KET040WP_03F_B</p>
<p><b>CSD84</b></p>  <p>FBP_NFDSL_04F_N</p>	<p><b>CSD92</b></p>  <p>AMP_SFT_03F_B</p>	<p><b>C11-1</b></p>  <p>AMP_8MM_01F_B</p>	<p><b>C11-2</b></p>  <p>KOSTAL_09447403</p>
<p><b>C12-1</b></p>  <p>AMP_GLOW_01F</p>	<p><b>C12-2</b></p>  <p>AMP_GLOW_01F</p>	<p><b>C12-3</b></p>  <p>AMP_GLOW_01F</p>	<p><b>C12-4</b></p>  <p>AMP_GLOW_01F</p>
<p><b>C12-5</b></p>  <p>AMP_GLOW_01F</p>	<p><b>C12-6</b></p>  <p>AMP_GLOW_01F</p>	<p><b>E34</b></p>  <p>AMP_JPT(BOSCH)_04F_B</p>	<p><b>F25</b></p>  <p>KET_090IWP_05F_Gr_2</p>
<p><b>F53-A</b></p>  <p>AMP_0407_26F_W_HD</p>	<p><b>M01-A</b></p>  <p>AMP_040M2_20F_B</p>	<p><b>M01-B</b></p>  <p>AMP_040M2_16F_B</p>	<p><b>M01-C</b></p>  <p>AMP_040M1_16F_B</p>

# MFI CONTROL SYSTEM

## MFI Control System (D6EA-DSL 3.0L) (8)

SD313-16

**M02-R**

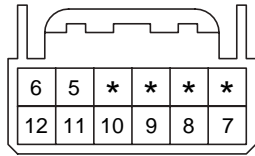

AMP\_025\_12F\_W

**M09**

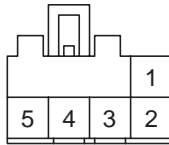

KUM\_CDR\_05F\_W

**M10**

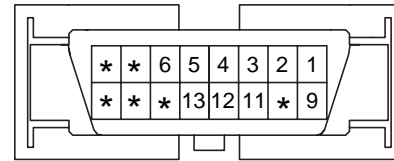

MLX\_OBDII\_16F\_B\_SIN

**M74**

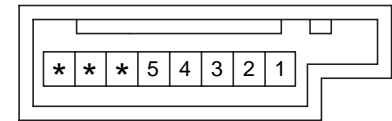





AMP\_1743386-1

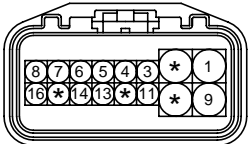
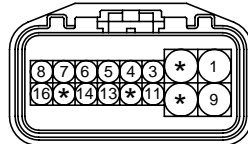
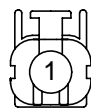

# STARTING SYSTEM

## Starting System (2)

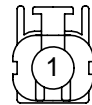
SD360-2

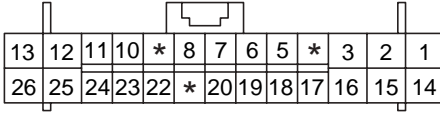
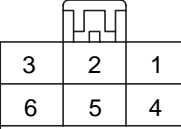
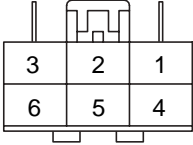
<p><b>CLG09</b></p>  <p>YAZ_TCMWP_16F_B</p>	<p><b>CSD09</b></p>  <p>YAZ_TCMWP_16F_B</p>	<p><b>E18</b></p>  <p>KET_58X_01F_B</p>	<p><b>E19</b></p>  <p>91990_3F500</p>
<p><b>E48</b></p>  <p>KET_58X_01F_B</p>	<p><b>E49</b></p>  <p>91990_3F500</p>	<p><b>M04-B</b></p>  <p>AMP_0407_26F_Gr_HD</p>	<p><b>M44</b></p>  <p>KUM_DSD_06F_W</p>
<p><b>M45</b></p>  <p>MLX_SD_06F_W</p>	<p><b>BLANK</b></p>	<p><b>BLANK</b></p>	<p><b>BLANK</b></p>

# FUEL FILLER HEATING SYSTEM (DSL)

E17EDC28

## Fuel Filter Heating System (DSL) (1)

SD361-1

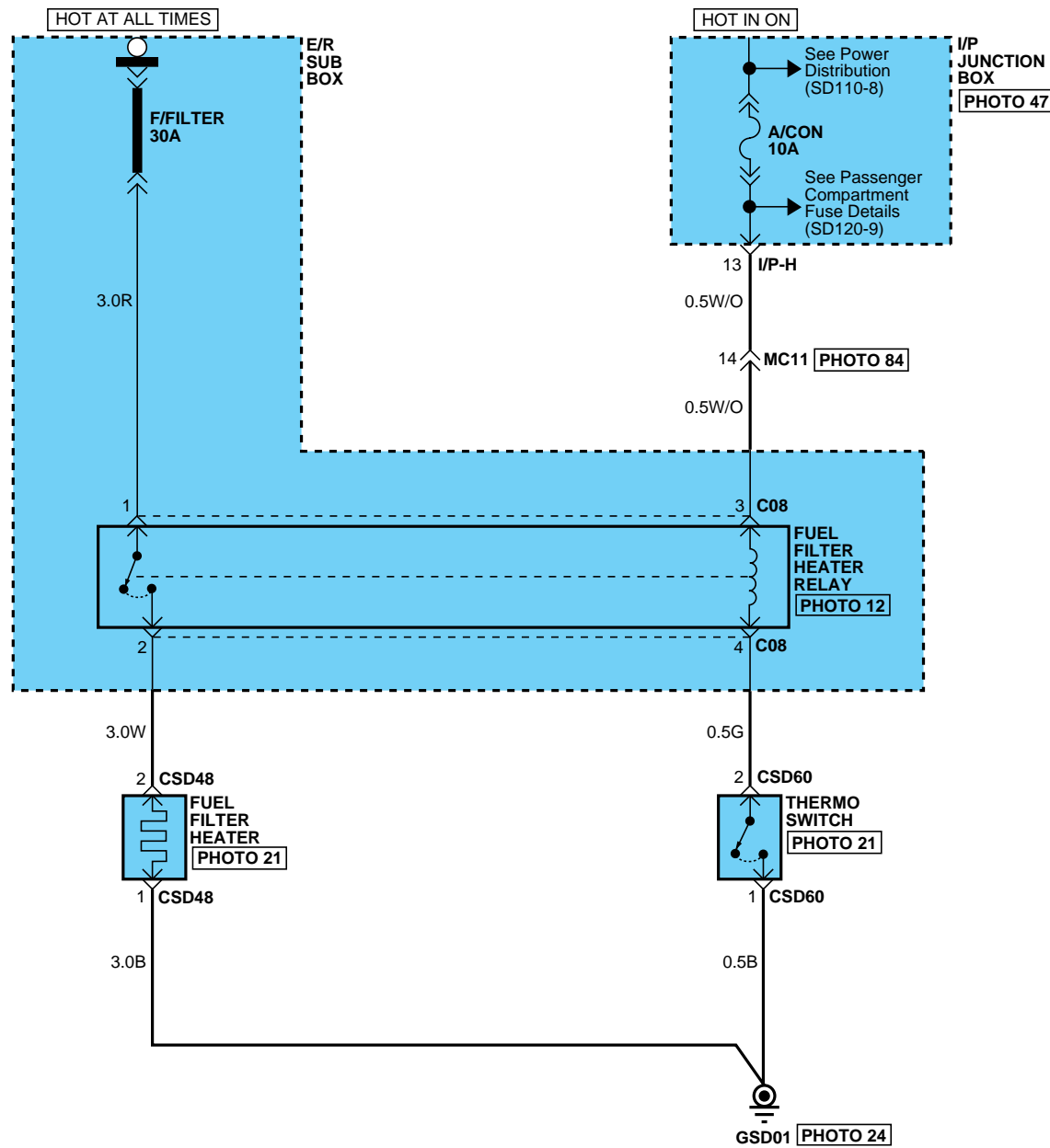

# FUEL FILLER HEATING SYSTEM (DSL)

## Fuel Filter Heating System (DSL) (2)

SD361-2

CSD48

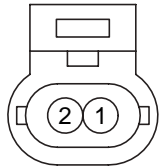

PKD\_280WP\_02F\_B\_1

CSD60

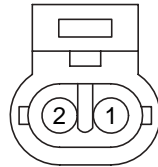

AMP\_060WP\_02F

C08

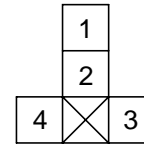

CR04F094

BLANK







# CHARGING SYSTEM

## Charging System (3)

SD373-3

CLG-A

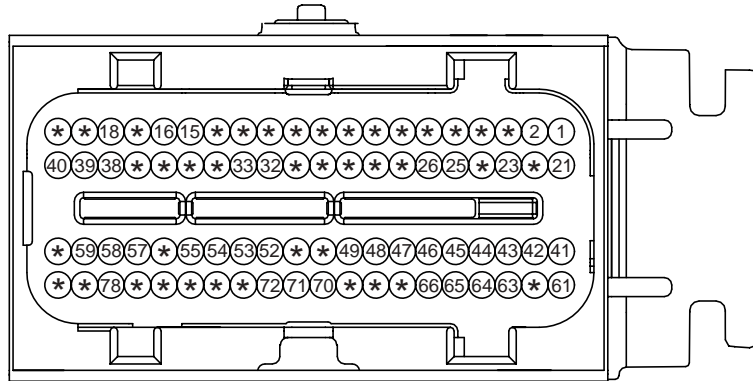

PKD\_ECU\_80F\_GR\_3

CLG-B

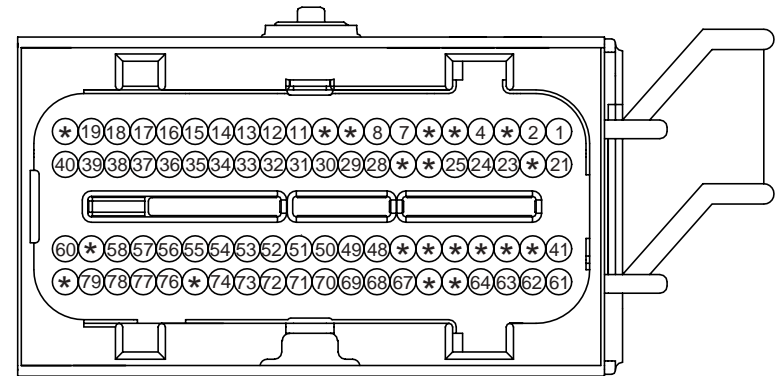

PKD\_ECU\_80F\_B\_4

CLG06

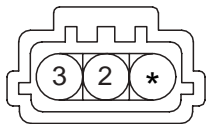

KET\_090IWP\_03F\_B

CLG80

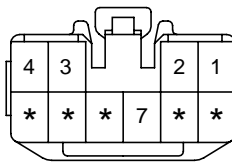

KET\_090II\_10F\_W

CSD06

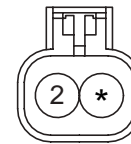

KET\_58X\_02F\_Gr

CSD80

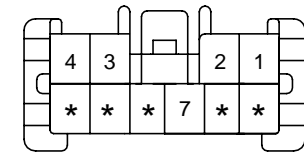

KET\_SDL11\_10F\_W

F53-A

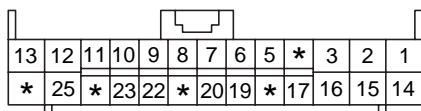

AMP\_0407\_26F\_W\_HD

M01-A

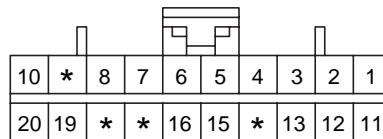

AMP\_040M2\_20F\_B

M01-C

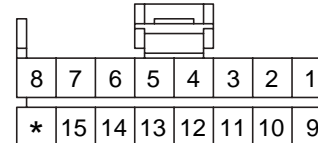

AMP\_040M1\_16F\_B

M04-D

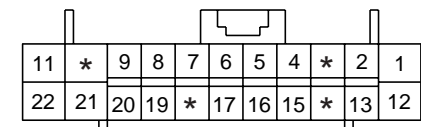

AMP\_0407\_22F\_W\_HD

M07-B

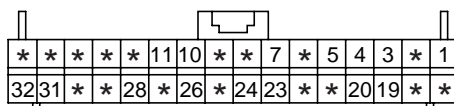

AMP\_025\_32F\_W

M24-A

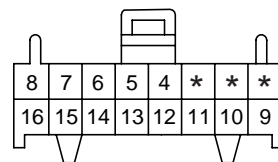

AMP\_DLL1\_16F\_B

M44

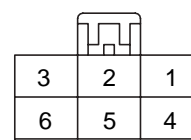

KUM\_DSD\_06F\_W

M45

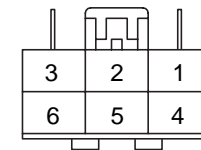

MLX\_5D\_06F\_W

**CHARGING SYSTEM**

Charging System (4)

SD373-4

MEMO

Vehicle Speed System (1)

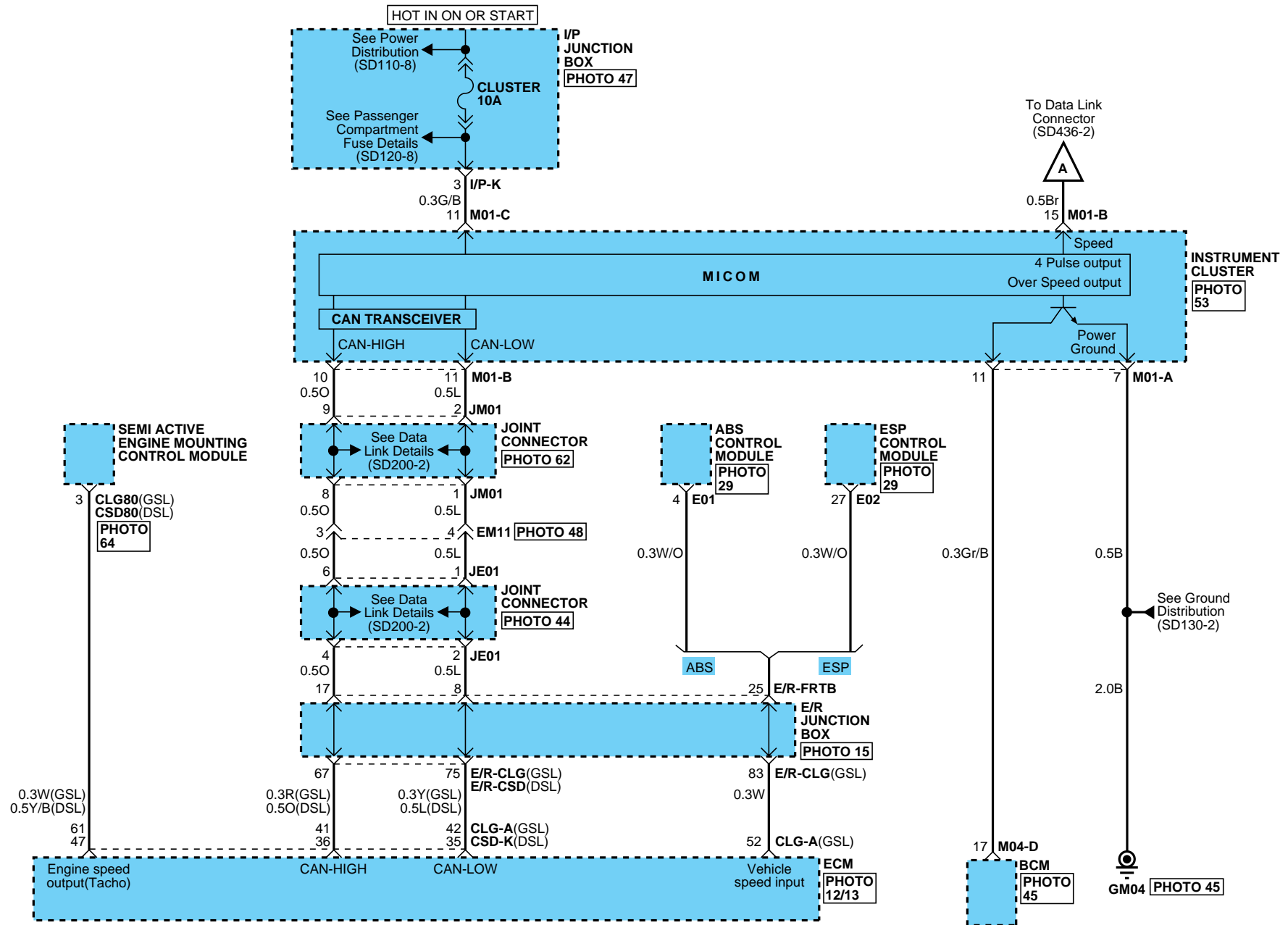

# VEHICLE SPEED SYSTEM

## Vehicle Speed System (2)

SD436-2

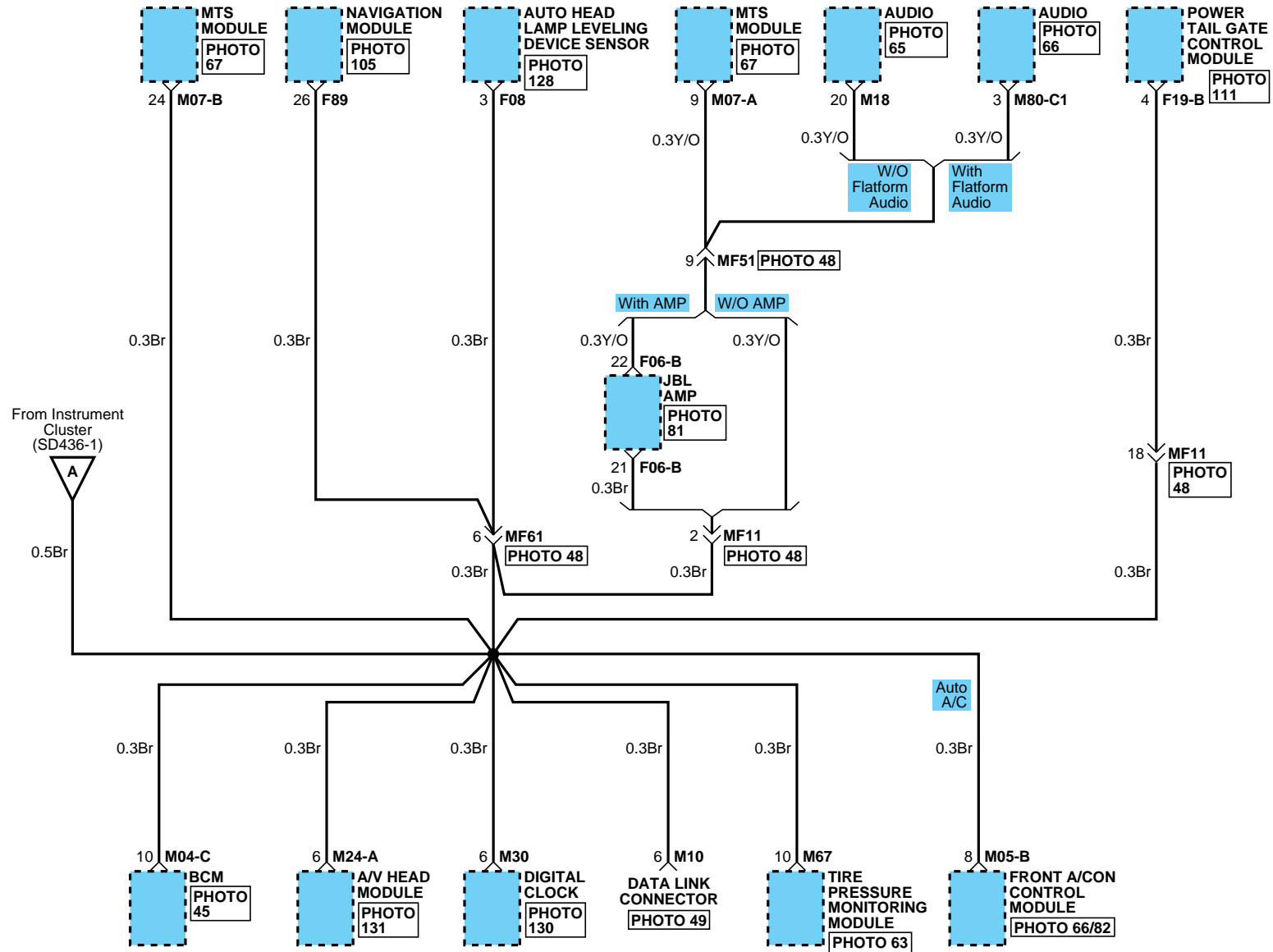



# VEHICLE SPEED SYSTEM

## Vehicle Speed System (2)

SD436-4

**M04-D**

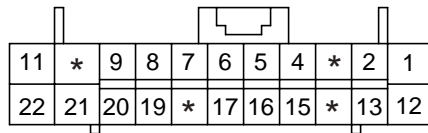

AMP\_0407\_22F\_W\_HD

**M05-B**

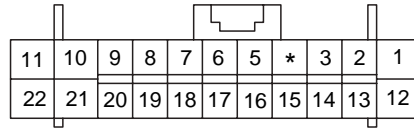

AMP\_0407\_22F\_W\_HD

**M07-A**

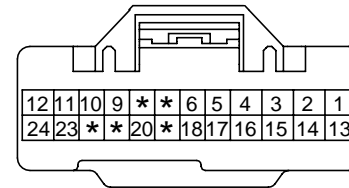

KET\_0409\_24F\_W

**M07-B**

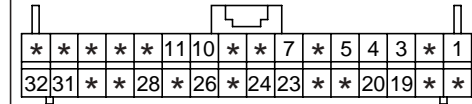

AMP\_025\_32F\_W

**M10**

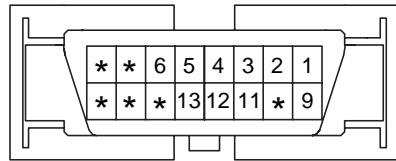

MLX\_OBDII\_16F\_B\_SIN

**M18**

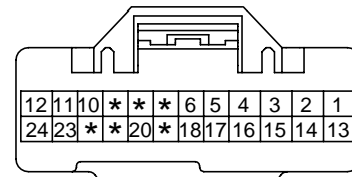

KET\_0409\_24F\_W

**M24-A**

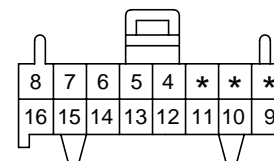

AMP\_DLI\_16F\_B

**M30**

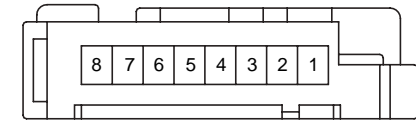

AMP\_MQS\_08F\_W

**M67**

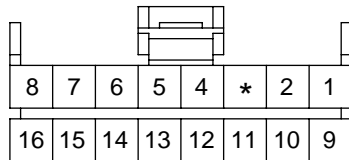

AMP\_040M1\_16F\_B

**M80-C1**

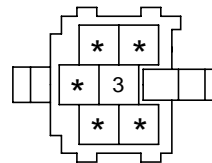

AMP\_AUDIO\_06F\_Y\_C1

**BLANK**

**BLANK**



**Automatic Transaxle Control System (1)**

**SD450-1**

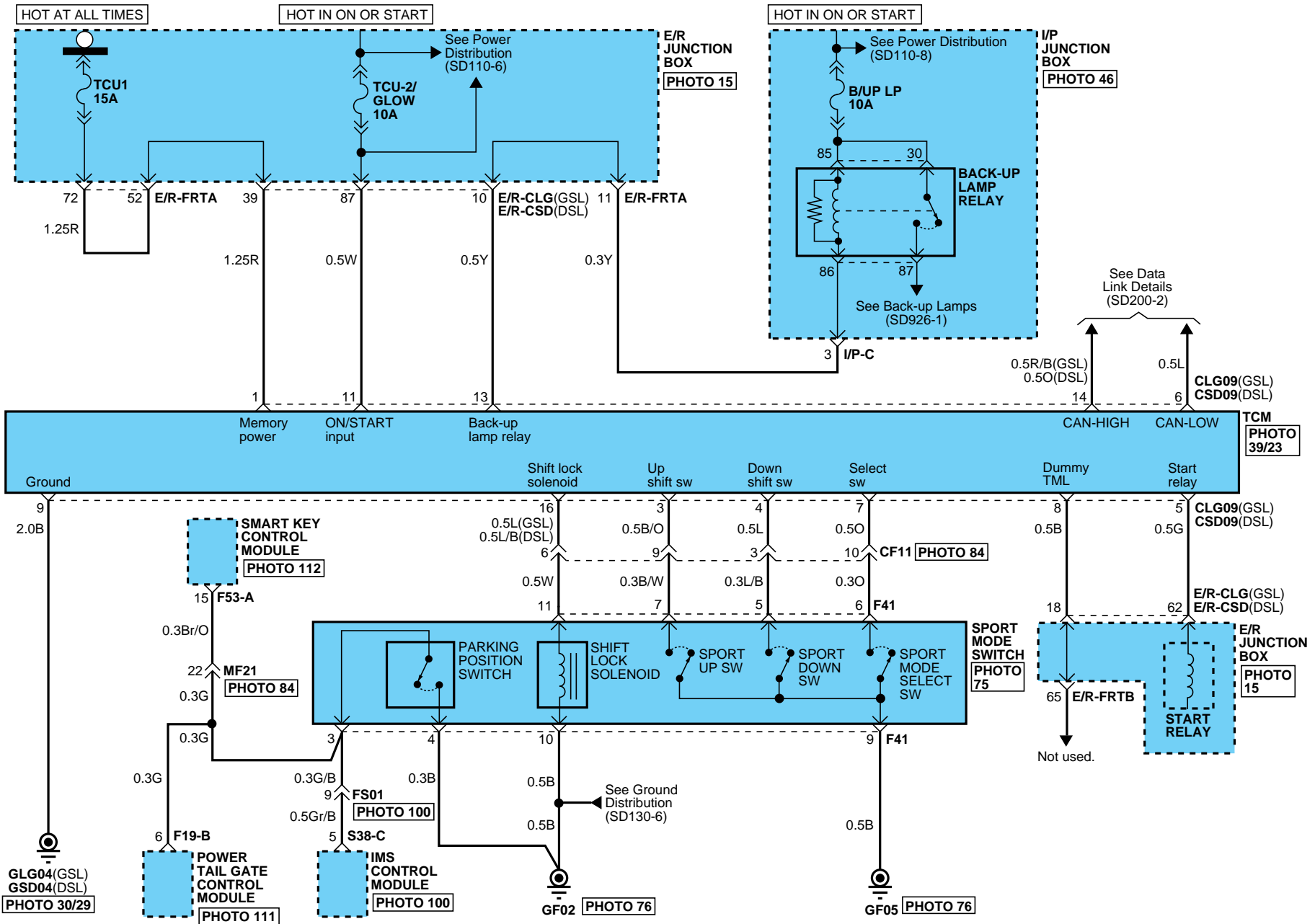

# AUTOMATIC TRANSAXLE CONTROL SYSTEM

## Automatic Transaxle Control System (2)

SD450-2

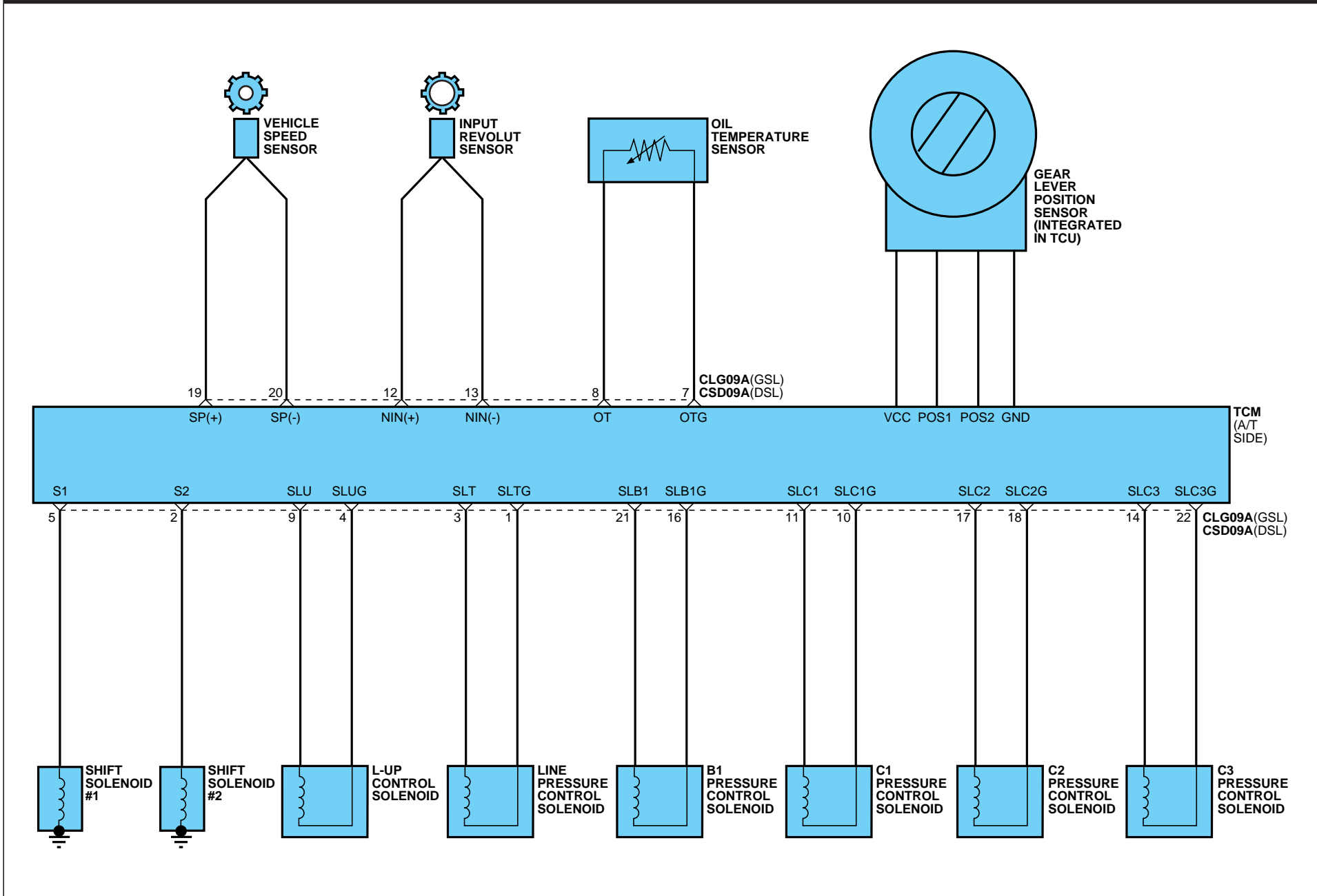

# AUTOMATIC TRANSAXLE CONTROL SYSTEM

## Automatic Transaxle Control System (3)

SD450-3

**CLG09**

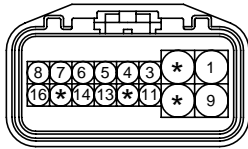

YAZ\_TCMWP\_16F\_B

**CSD09**

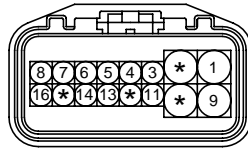

YAZ\_TCMWP\_16F\_B

**CLG09A**

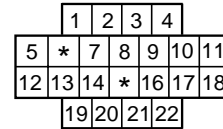

CR22F017

**CSD09A**

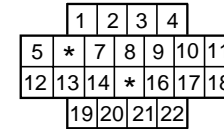

CR22F017

**F19-B**

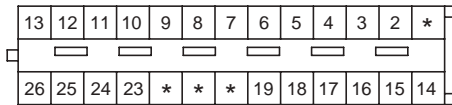

AMP\_MQS\_26F\_B

**F41**

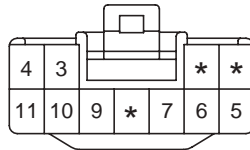

KET\_090II\_11F\_W

**F53-A**

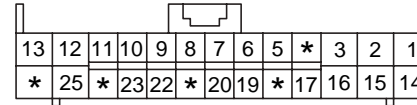

AMP\_0407\_26F\_W\_HD

**S38-C**

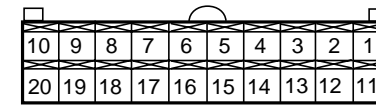

CR20F021

# AUTOMATIC TRANSAXLE CONTROL SYSTEM

Automatic Transaxle Control System (4)

SD450-4

MEMO

Transfer Case Control System (TCCS) (1)

SD527-1

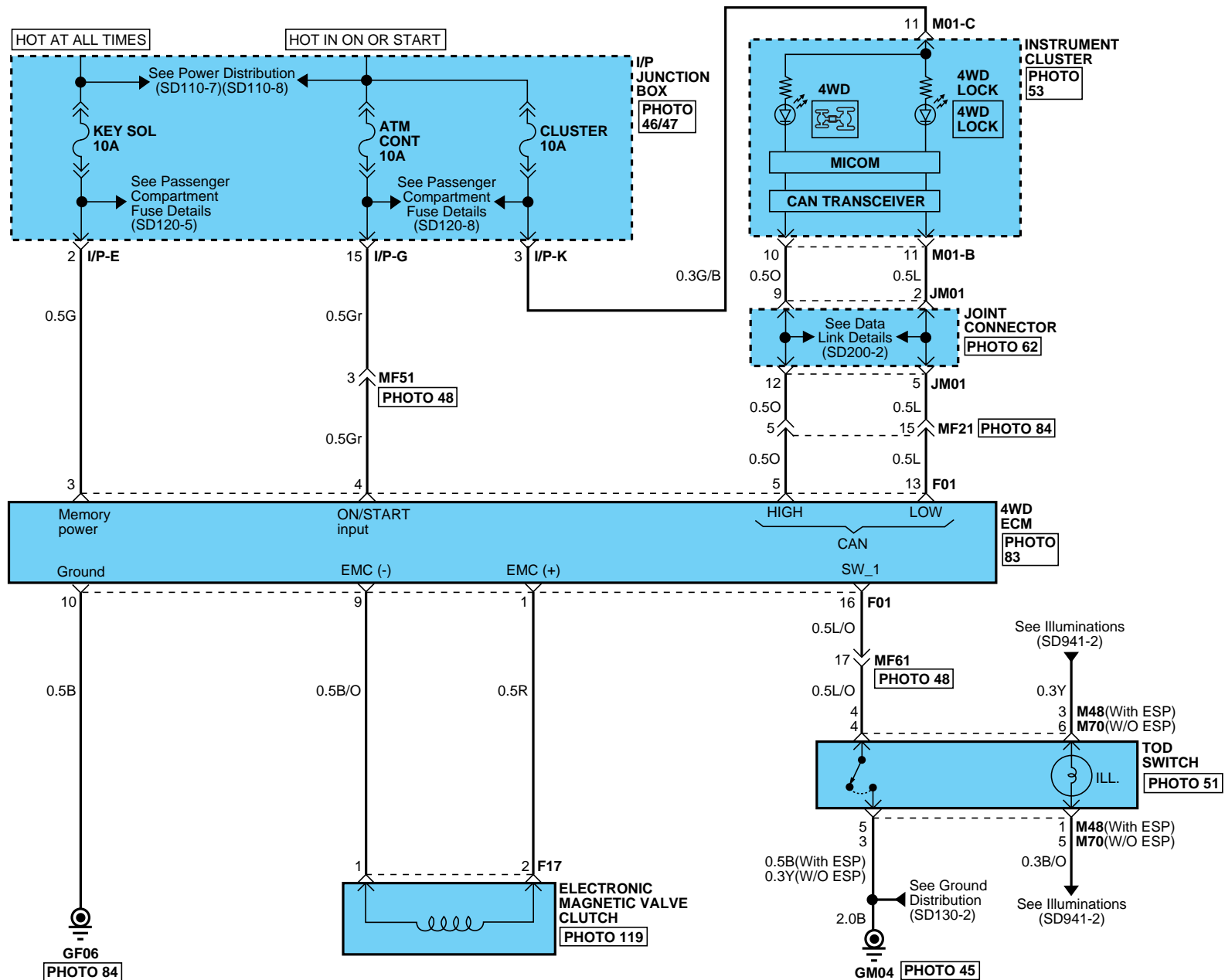

# TRANSFER CASE CONTROL SYSTEM (TCCS)

## Transfer Case Control System (TCCS) (2)

SD527-2

**F01**

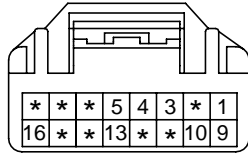

YAZ\_025\_16F\_W

**F17**



SUM\_090WP\_02F\_Gr

**M01-B**

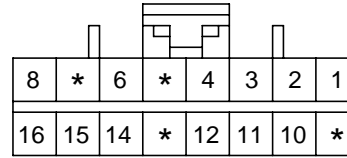

AMP\_040M2\_16F\_B

**M01-C**

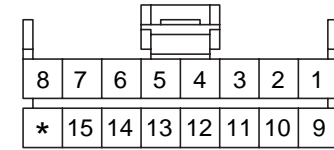

AMP\_040M1\_16F\_B

**M48**

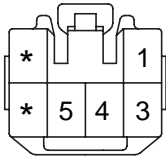

KET\_090II\_06F\_L\_SW

**M70**

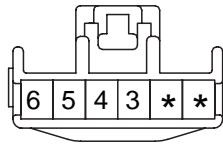

KET\_090II\_06F\_L

**BLANK**

**BLANK**

Steering Tilt & Telescopic System (1)

SD564-1

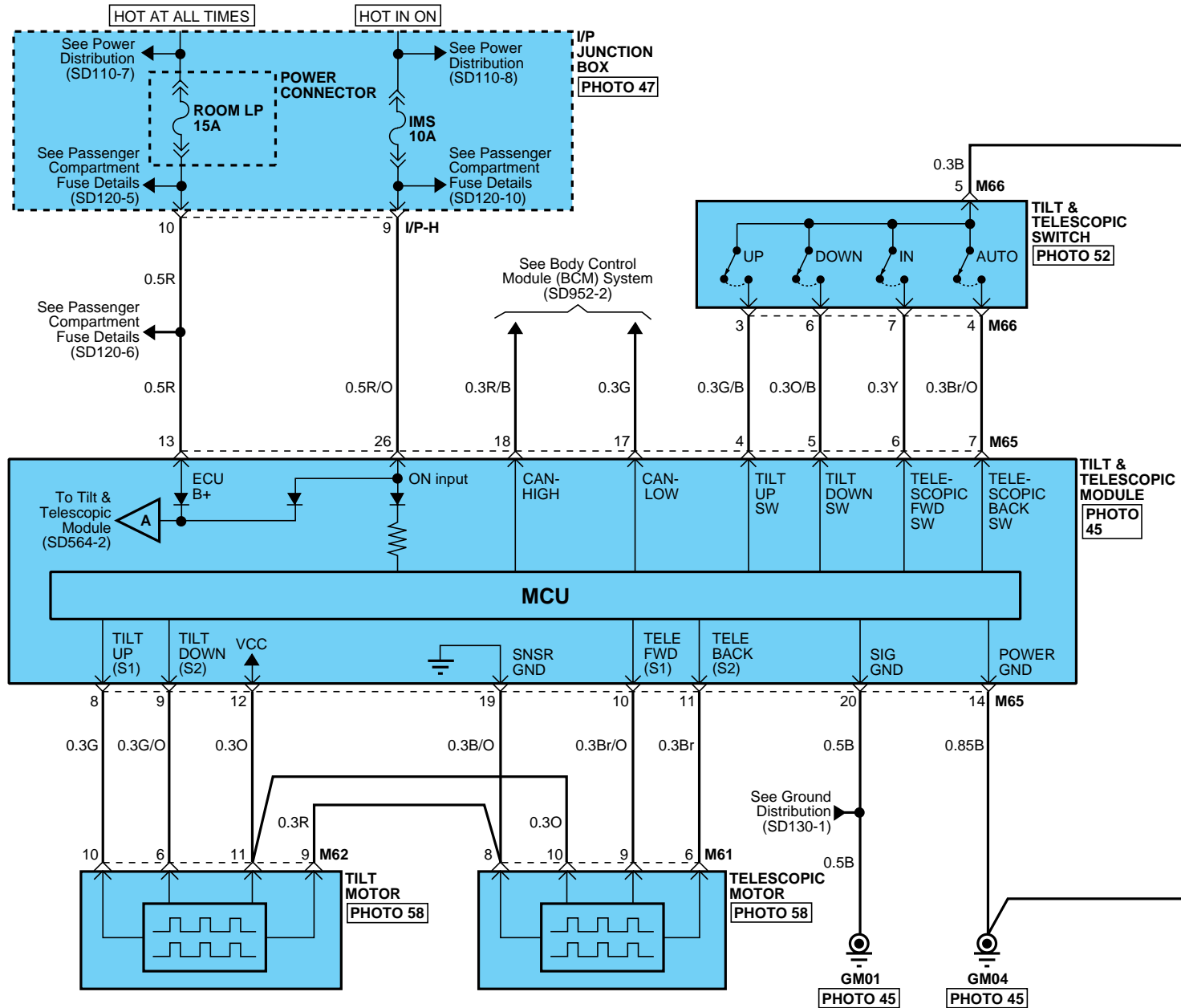

# STEERING TILT & TELESCOPIC SYSTEM

## Steering Tilt & Telescopic System (2)

SD564-2

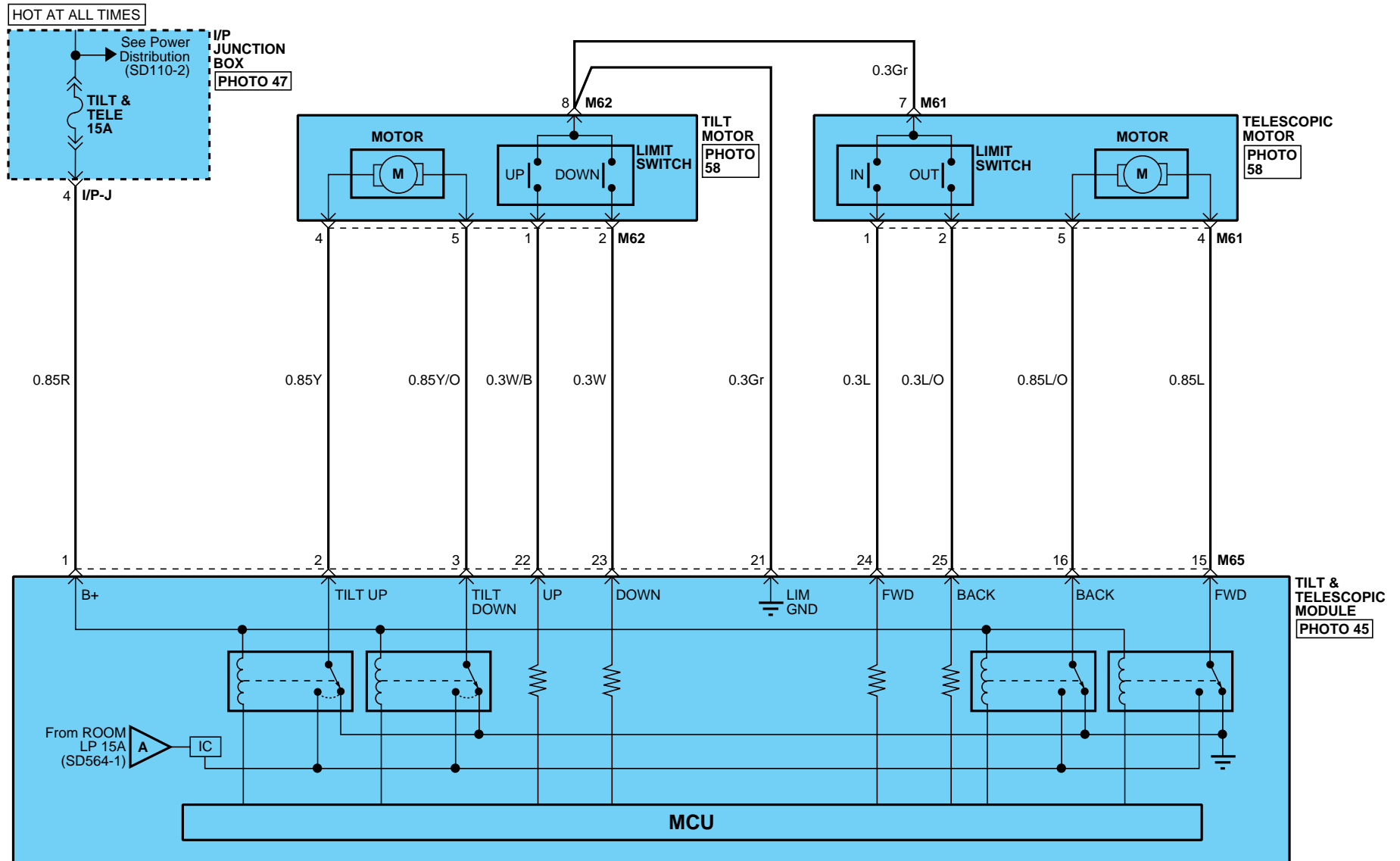



# STEERING TILT & TELESCOPIC SYSTEM

## Steering Tilt & Telescopic System (3)

SD564-3

**M61**

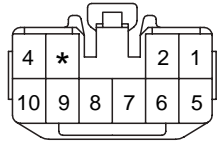

KET\_090II\_10F\_B

**M62**

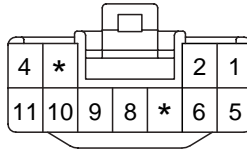

KET\_090II\_11F\_W

**M65**

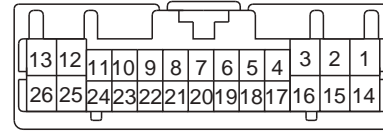

KET\_0407\_26F\_B

**M66**

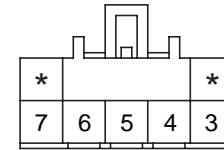

KUM\_CDR\_07F\_W

**STEERING TILT & TELESCOPIC SYSTEM**

**Steering Tilt & Telescopic System (4)**

**SD564-4**

**MEMO**



# SUPPLEMENTAL RESTRAINT SYSTEM (SRS)

## Supplemental Restraint System (SRS) (2)

SD569-2

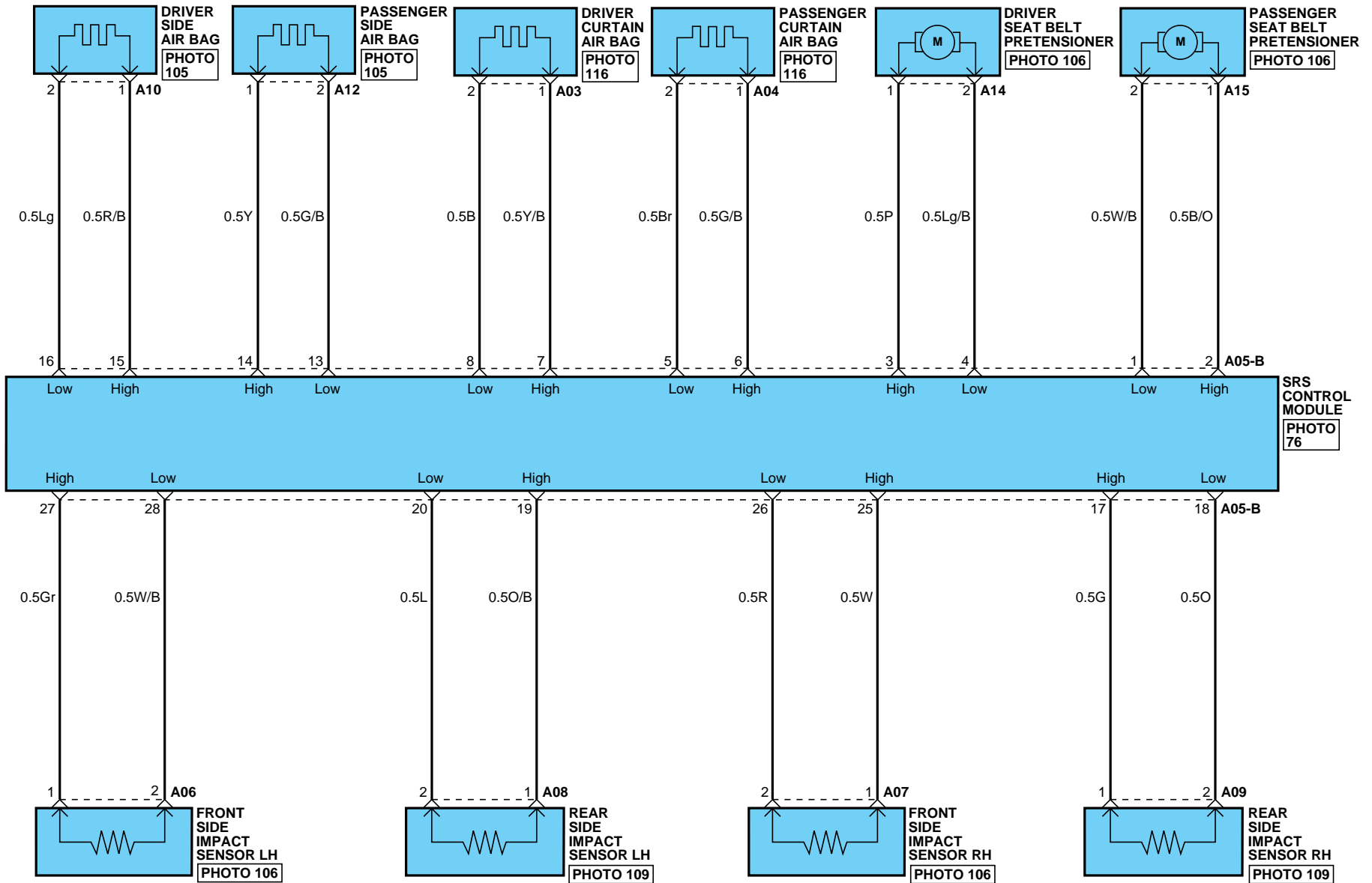

# SUPPLEMENTAL RESTRAINT SYSTEM (SRS)

## Supplemental Restraint System (SRS) (3)

SD569-3

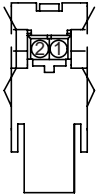
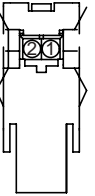
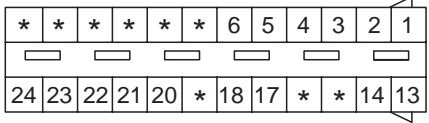
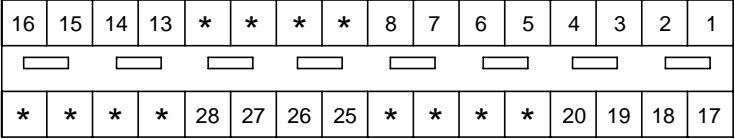
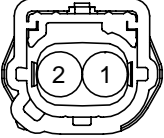
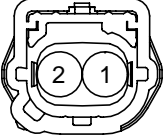
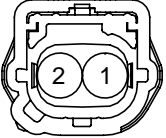
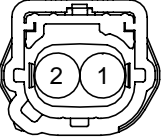
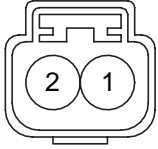
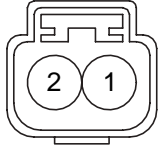
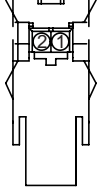
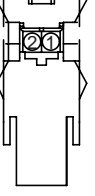
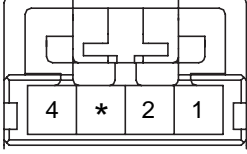
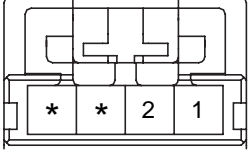
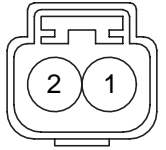
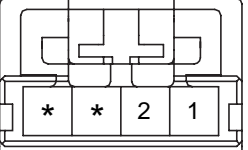
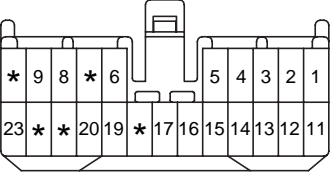
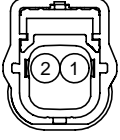
<p><b>A03</b></p>  <p>JST_SQS_02F_B</p>	<p><b>A04</b></p>  <p>JST_SQS_02F_B</p>	<p><b>A05-A</b></p>  <p>AMP_ABG_24F_L_ECU</p>	<p><b>BLANK</b></p>
<p><b>A05-B</b></p>  <p>AMP_ABG_32F_B_ECU</p>		<p><b>A06</b></p>  <p>MLX_ABAG_02F_B</p>	<p><b>A07</b></p>  <p>MLX_ABAG_02F_B</p>
<p><b>A08</b></p>  <p>MLX_ABAG_02F_B</p>	<p><b>A09</b></p>  <p>MLX_ABAG_02F_B</p>	<p><b>A10</b></p>  <p>YAZ_040WP_02F_Y_GH</p>	<p><b>A12</b></p>  <p>YAZ_040WP_02F_Y_GH</p>
<p><b>A14</b></p>  <p>JST_SQH_02F_B</p>	<p><b>A15</b></p>  <p>JST_SQH_02F_B</p>	<p><b>A17</b></p>  <p>AMP_MQS_04F_B_040</p>	<p><b>A18</b></p>  <p>YAZ_040_04F_Y</p>
<p><b>A19</b></p>  <p>YAZ_040WP_02F_Y</p>	<p><b>A20</b></p>  <p>AMP_MQS_04F_B_040</p>	<p><b>D03-B</b></p>  <p>KET_050_23F_W</p>	<p><b>E28</b></p>  <p>MLX_ABAG_02F_B</p>

# SUPPLEMENTAL RESTRAINT SYSTEM (SRS)

## Supplemental Restraint System (SRS) (4)

SD569-4

**E38**

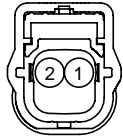

MLX\_ABAG\_02F\_B

**M01-A**

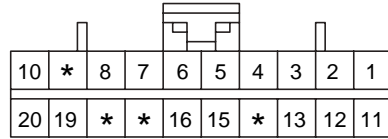

AMP\_040M2\_20F\_B

**M10**

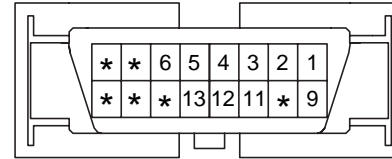

MLX\_OBDII\_16F\_B\_SIN

**BLANK**



# ANTI-LOCK BRAKE SYSTEM (ABS)

## Anti-Lock Brake System (ABS) (2)

SD587-2

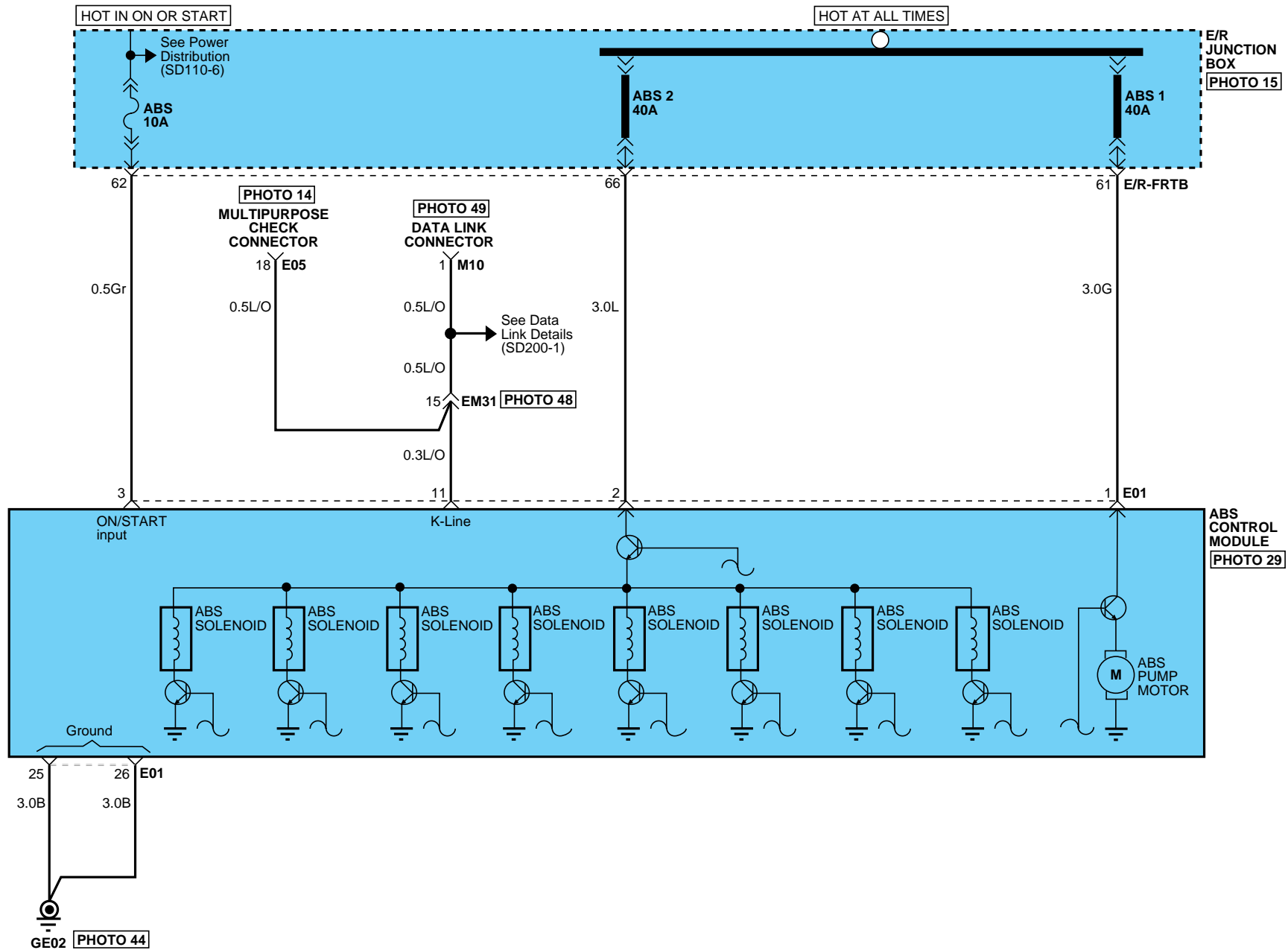



# ANTI-LOCK BRAKE SYSTEM (ABS)

## Anti-Lock Brake System (ABS) (3)

SD587-3

**CLG-A**

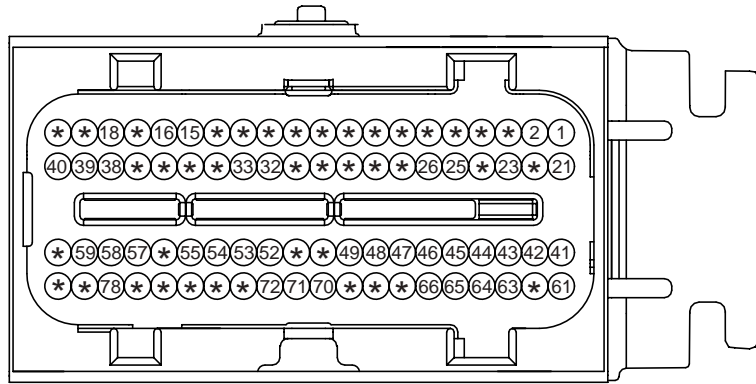

PKD\_ECU\_80F\_Gr\_3

**CLG43**

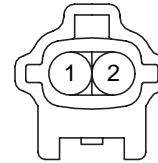

KET\_090IWP\_02M\_B

**CLG58**

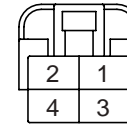

KET\_250DL\_04F\_W

**CLG83**

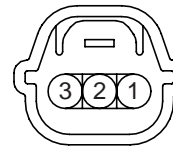

KET\_SSD\_03F\_Gr

**CSD43**

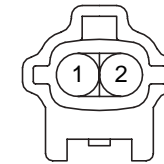

KET\_090IWP\_02M\_B

**CSD58**

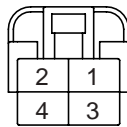

KET\_250DL\_04F\_W

**CSD83**

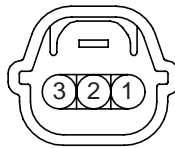

KET\_SSD\_03F\_Gr

**E01**

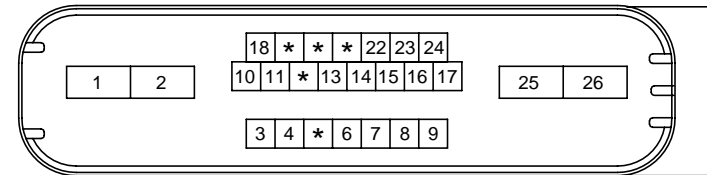

FCI\_ABS\_26F\_B

**E05**



KET\_DIAGNOSIS\_20F\_B\_A

**E12**

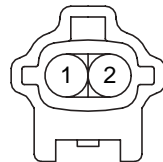

KET\_090IWP\_02M\_B

**F51**

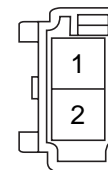

KET\_090II\_02M\_W

**F52**

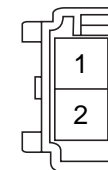

KET\_090II\_02M\_W

**M01-B**

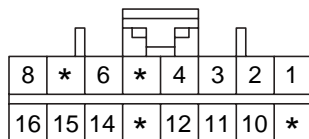

AMP\_040M2\_16F\_B

**M01-C**

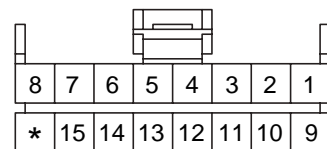

AMP\_040M1\_16F\_B

**M10**

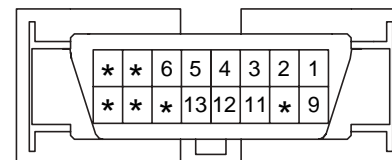

MLX\_OBDII\_16F\_B\_SIN

**BLANK**

## ANTI-LOCK BRAKE SYSTEM (ABS)

Anti-Lock Brake System (ABS) (4)

SD587-4

MEMO



# ELECTRONIC STABILITY PROGRAM (ESP) SYSTEM

## Electronic Stability Program (ESP) System (2)

SD588-2

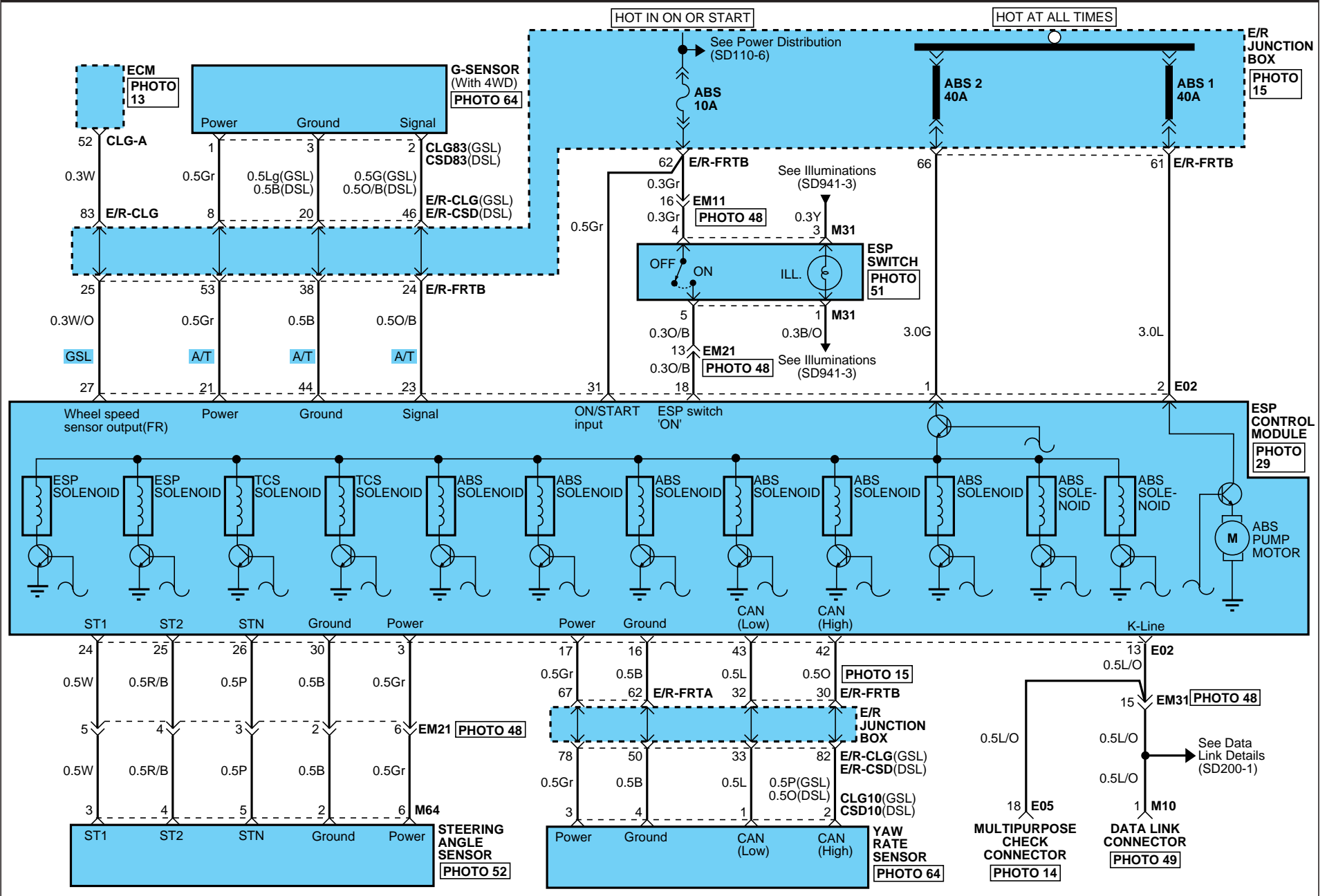

# ELECTRONIC STABILITY PROGRAM (ESP) SYSTEM

## Electronic Stability Program (ESP) System (3)

SD588-3

**CLG-A**

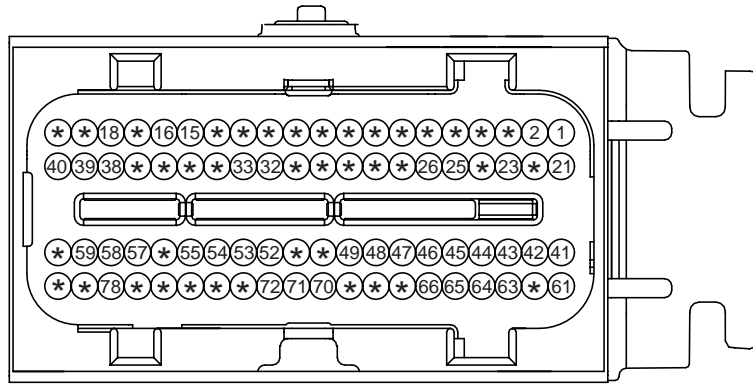

PKD\_ECU\_80F\_GR\_3

**CLG10**

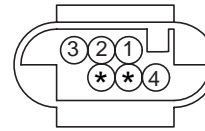

AMP\_MQSWP\_06F\_B\_1

**CLG43**

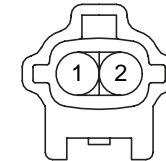

KET\_090IWP\_02M\_B

**CLG58**

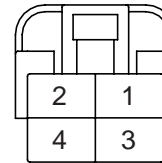

KET\_250DL\_04F\_W

**CLG83**

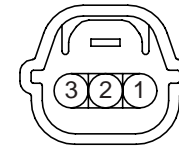

KET\_SSD\_03F\_Gr

**CSD10**

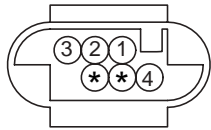

AMP\_MQSWP\_06F\_B\_1

**CSD43**

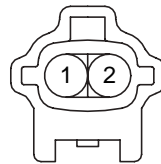

KET\_090IWP\_02M\_B

**CSD58**

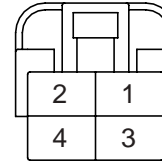

KET\_250DL\_04F\_W

**CSD83**



KET\_SSD\_03F\_Gr

**E02**

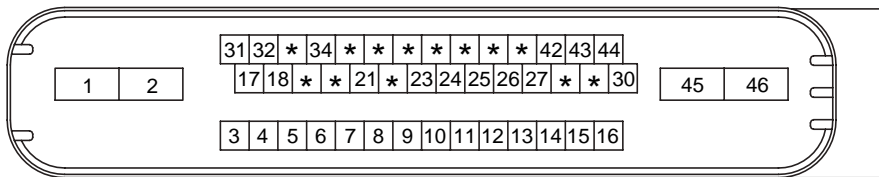

FCI\_ESP\_46F\_B

**E05**

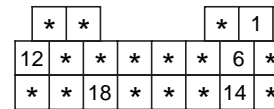

KET\_DIAGNOSIS\_20F\_B\_A

**E07**

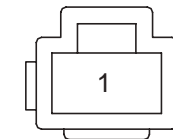

KET\_250\_01M\_B

**E12**

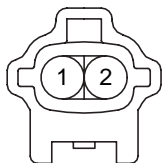

KET\_090IWP\_02M\_B

**F51**

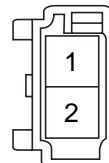

KET\_090II\_02M\_W

**F52**

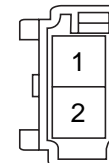

KET\_090II\_02M\_W

**M01-A**

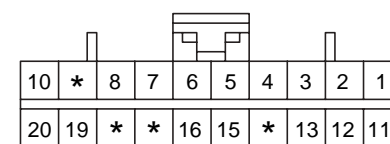

AMP\_040M2\_20F\_B

# ELECTRONIC STABILITY PROGRAM (ESP) SYSTEM

## Electronic Stability Program (ESP) System (4)

SD588-4

**M01-B**

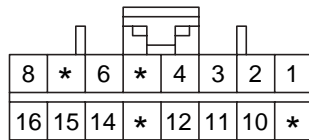

AMP\_040M2\_16F\_B

**M01-C**

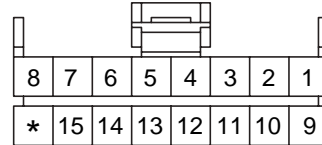

AMP\_040M1\_16F\_B

**M10**

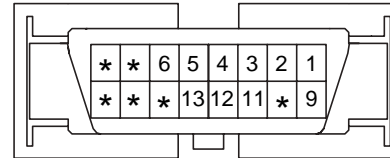

MLX\_OBDII\_16F\_B\_SIN

**M31**

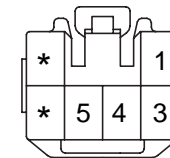

KET\_090II\_06F\_Gr

**M64**

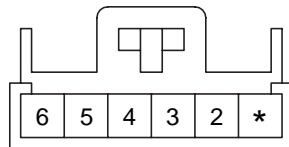

AMP\_070\_06F\_W\_1F

**BLANK**

**BLANK**

**BLANK**

Fuel Filler Door (1)

SD812-1

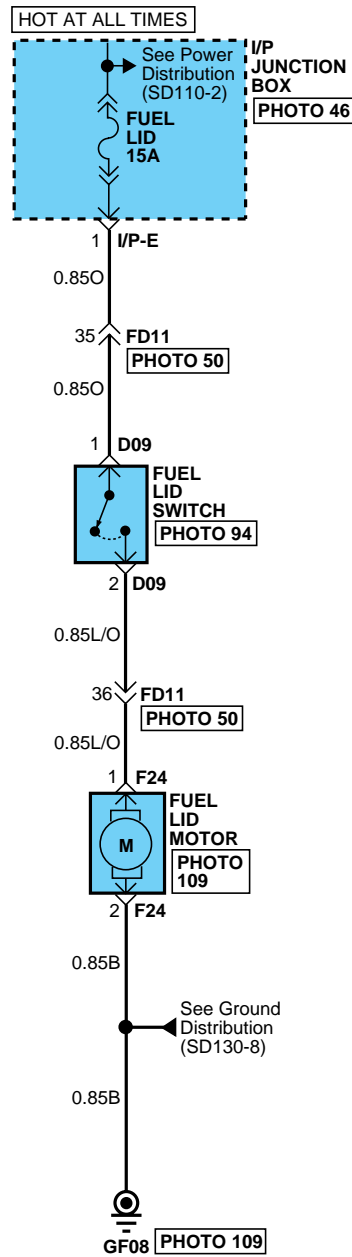

# FUEL FILLER DOOR

Fuel Filler Door (2)

SD812-2

D09

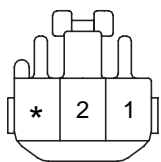

KET\_090III\_03F\_Y

F24

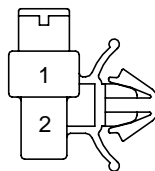

KET\_250\_02F\_B\_CLIP

BLANK

BLANK



Power Door Locks (1)

SD813-1

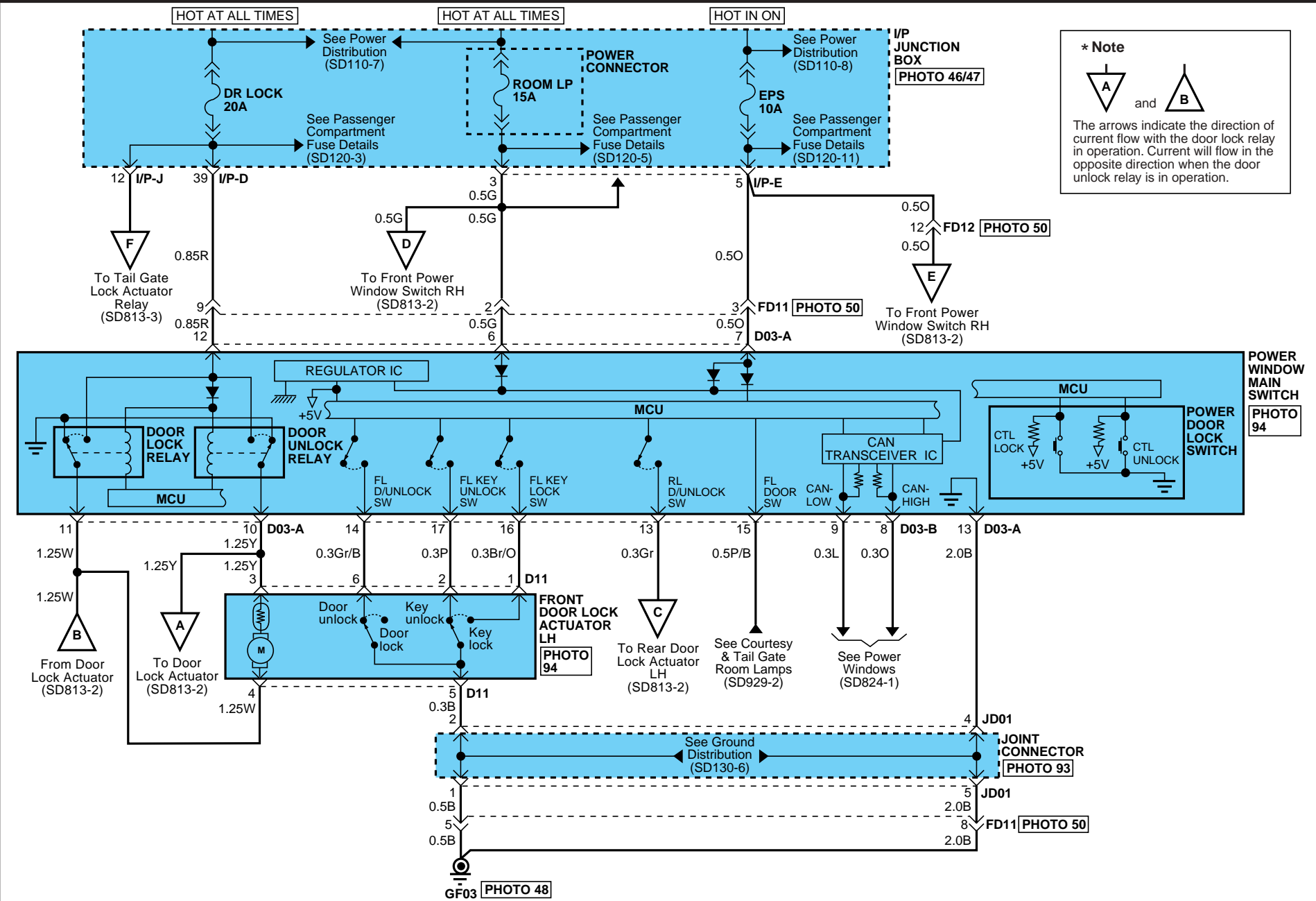

# POWER DOOR LOCKS

## Power Door Locks (2)

SD813-2

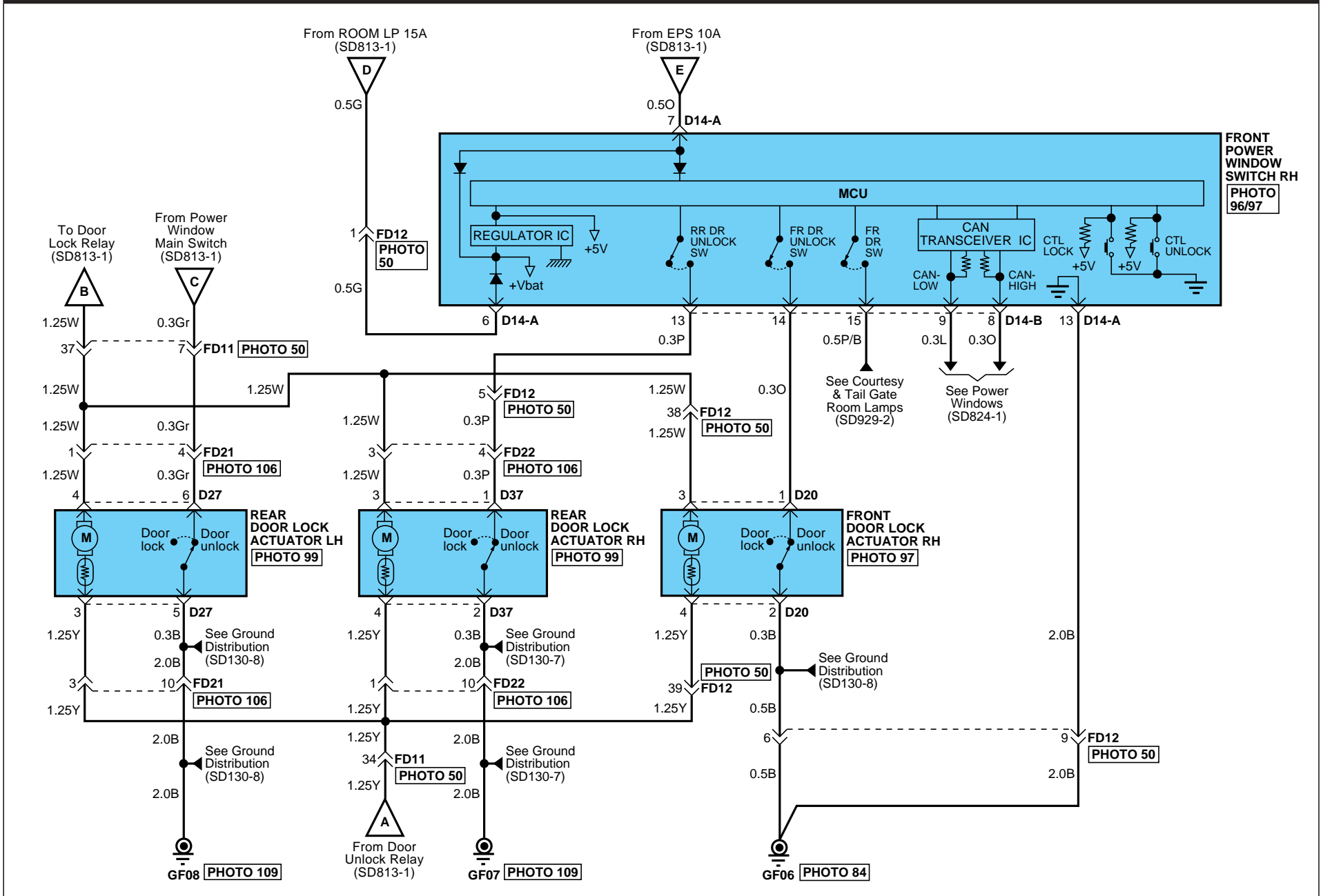



# POWER DOOR LOCKS

## Power Door Locks (4)

SD813-4

**D03-A**

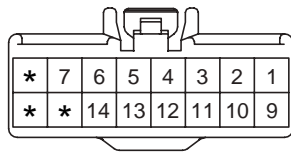

KET\_090III\_16F\_Y

**D03-B**

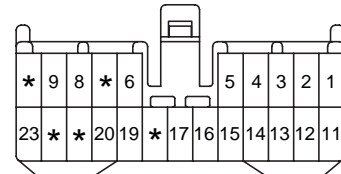

KET\_050\_23F\_W

**D11**

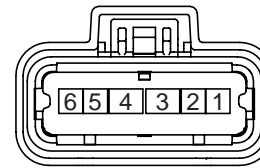

FCI\_MINIWP\_06F\_B

**D14-A**

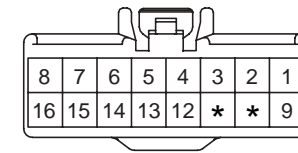

KET\_090III\_16F\_Y

**D14-B**

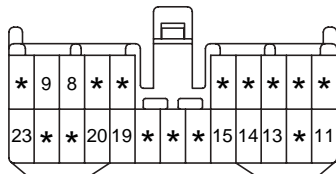

KET\_050\_23F\_W

**D20**

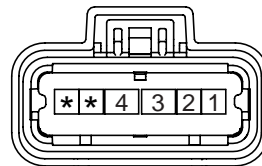

FCI\_MINIWP\_06F\_B

**D27**

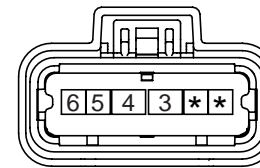

FCI\_MINIWP\_06F\_B

**D37**

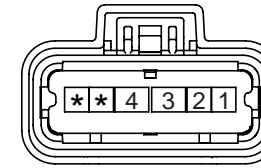

FCI\_MINIWP\_06F\_B

**M04-B**

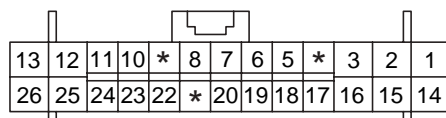

AMP\_0407\_26F\_Gr\_HD

**M04-D**

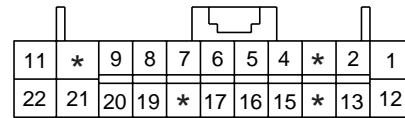

AMP\_0407\_22F\_W\_HD

**M08-A**

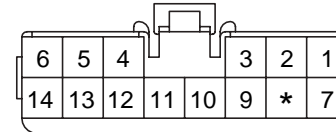

KET\_090II\_14F\_W

**R10**

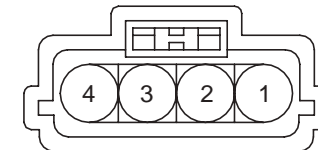

KUM\_NDWP\_04F\_B



# SMART KEY SYSTEM

## Smart Key System (2)

SD815-2

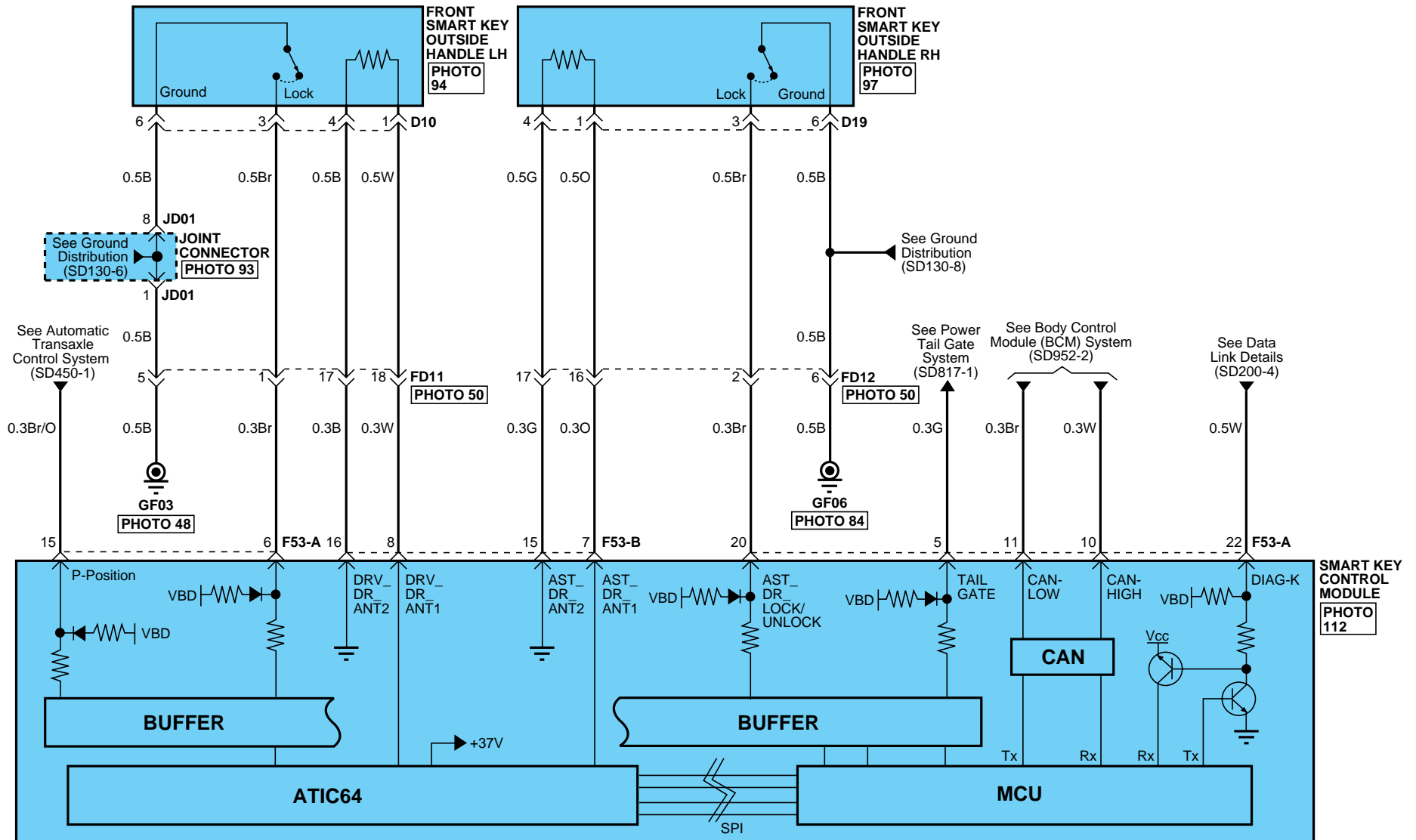

# SMART KEY SYSTEM

## Smart Key System (3)

SD815-3

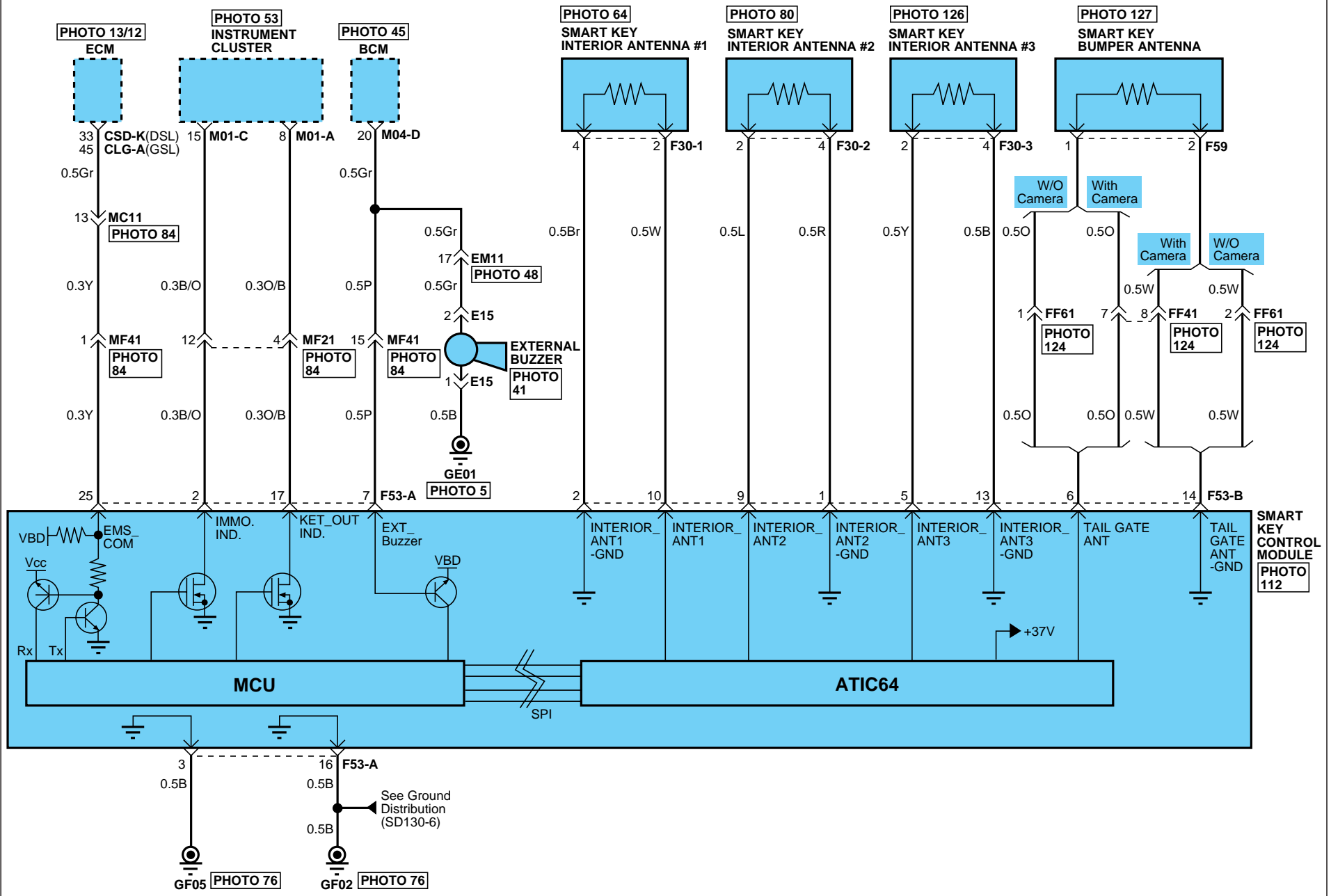

# SMART KEY SYSTEM

## Smart Key System (4)

SD815-4

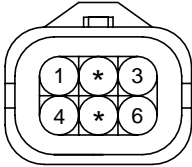
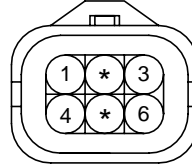
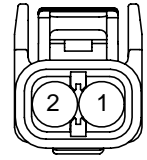
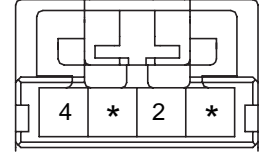
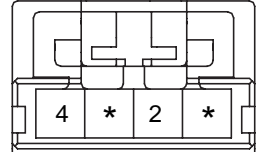
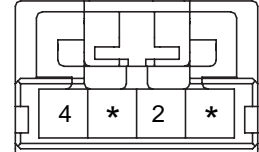
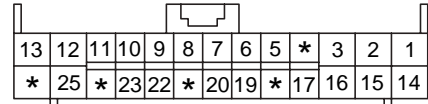
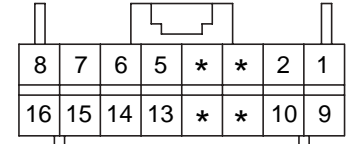
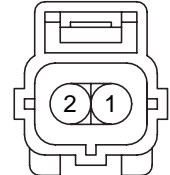
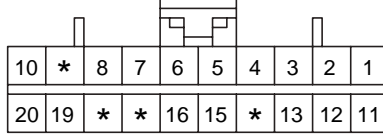
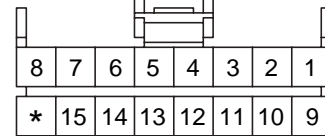
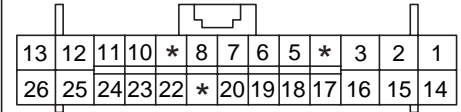
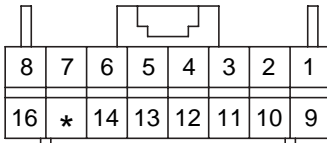
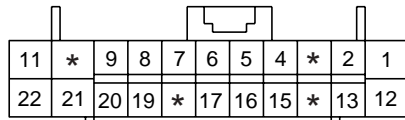
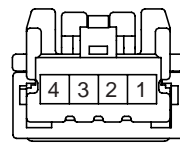
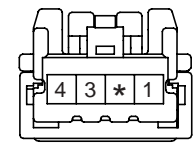
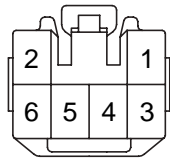
<p><b>D10</b></p>  <p>YAZ_040WP_06M_Gr</p>	<p><b>D19</b></p>  <p>YAZ_040WP_06M_Gr</p>	<p><b>E15</b></p>  <p>KET_090IWP_02F_B</p>	<p><b>F30-1</b></p>  <p>AMP_MQS_04F_B_040</p>
<p><b>F30-2</b></p>  <p>AMP_MQS_04F_B_040</p>	<p><b>F30-3</b></p>  <p>AMP_MQS_04F_B_040</p>	<p><b>F53-A</b></p>  <p>AMP_0407_26F_W_HD</p>	<p><b>F53-B</b></p>  <p>AMP_0407_16F_W_040</p>
<p><b>F59</b></p>  <p>AMP_EJWP_02F_B</p>	<p><b>M01-A</b></p>  <p>AMP_040M2_20F_B</p>	<p><b>M01-C</b></p>  <p>AMP_040M1_16F_B</p>	<p><b>M04-B</b></p>  <p>AMP_0407_26F_Gr_HD</p>
<p><b>M04-C</b></p>  <p>AMP_0407_16F_W_040</p>	<p><b>M04-D</b></p>  <p>AMP_0407_22F_W_HD</p>	<p><b>M50</b></p>  <p>KET_040III_04F_W</p>	<p><b>M54</b></p>  <p>KET_040III_04F_W</p>
<p><b>M63</b></p>  <p>KET_090II_06F_W</p>	<p><b>BLANK</b></p>	<p><b>BLANK</b></p>	<p><b>BLANK</b></p>



Sunroof (1)

SD816-1

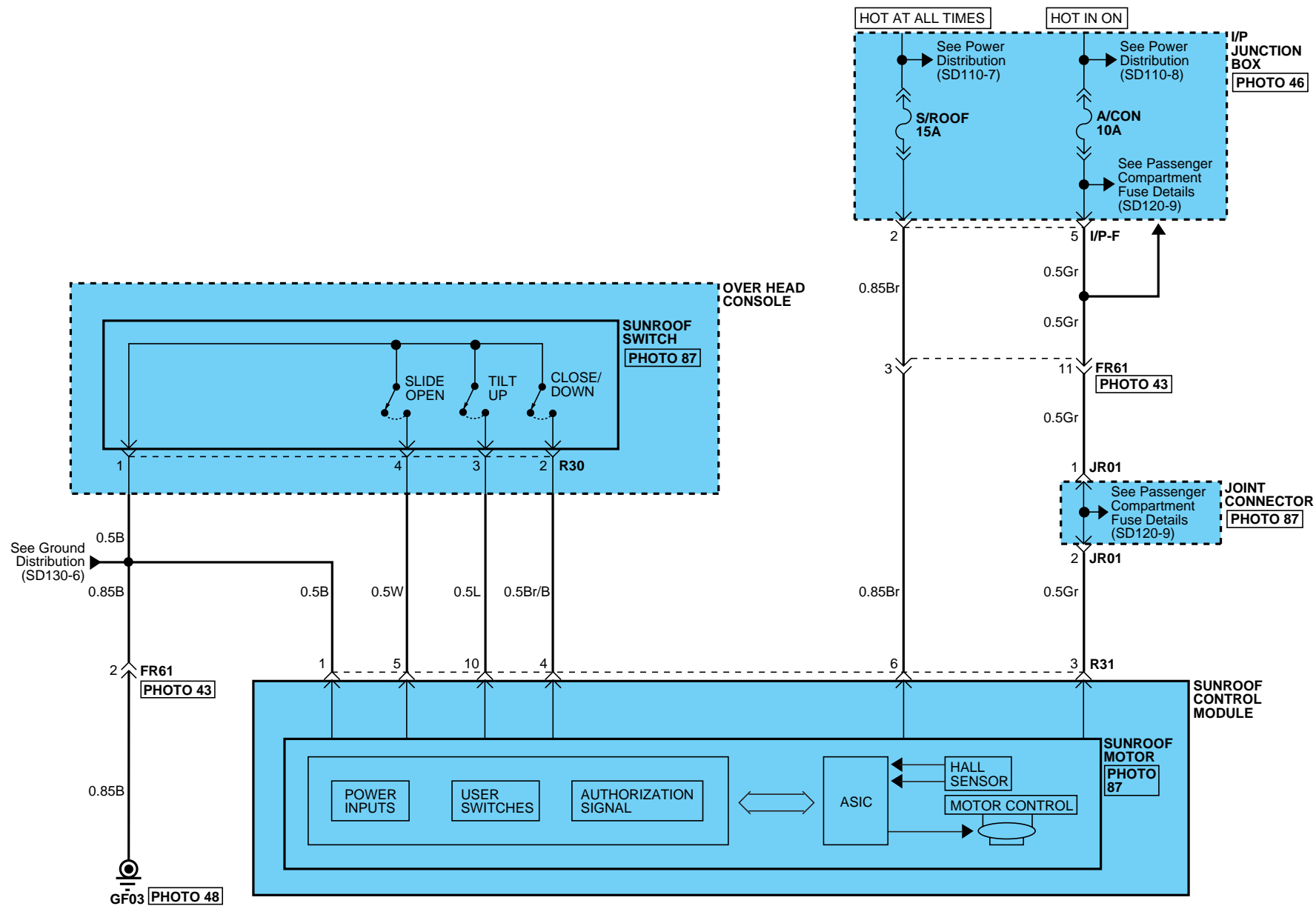

# SUNROOF

Sunroof (2)

SD816-2

R30

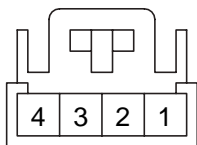

AMP\_070\_04F\_W

R31

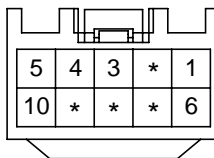

YAZ\_1.5SYS\_10F\_Gr

BLANK

BLANK

Power Tail Gate System (1)

SD817-1

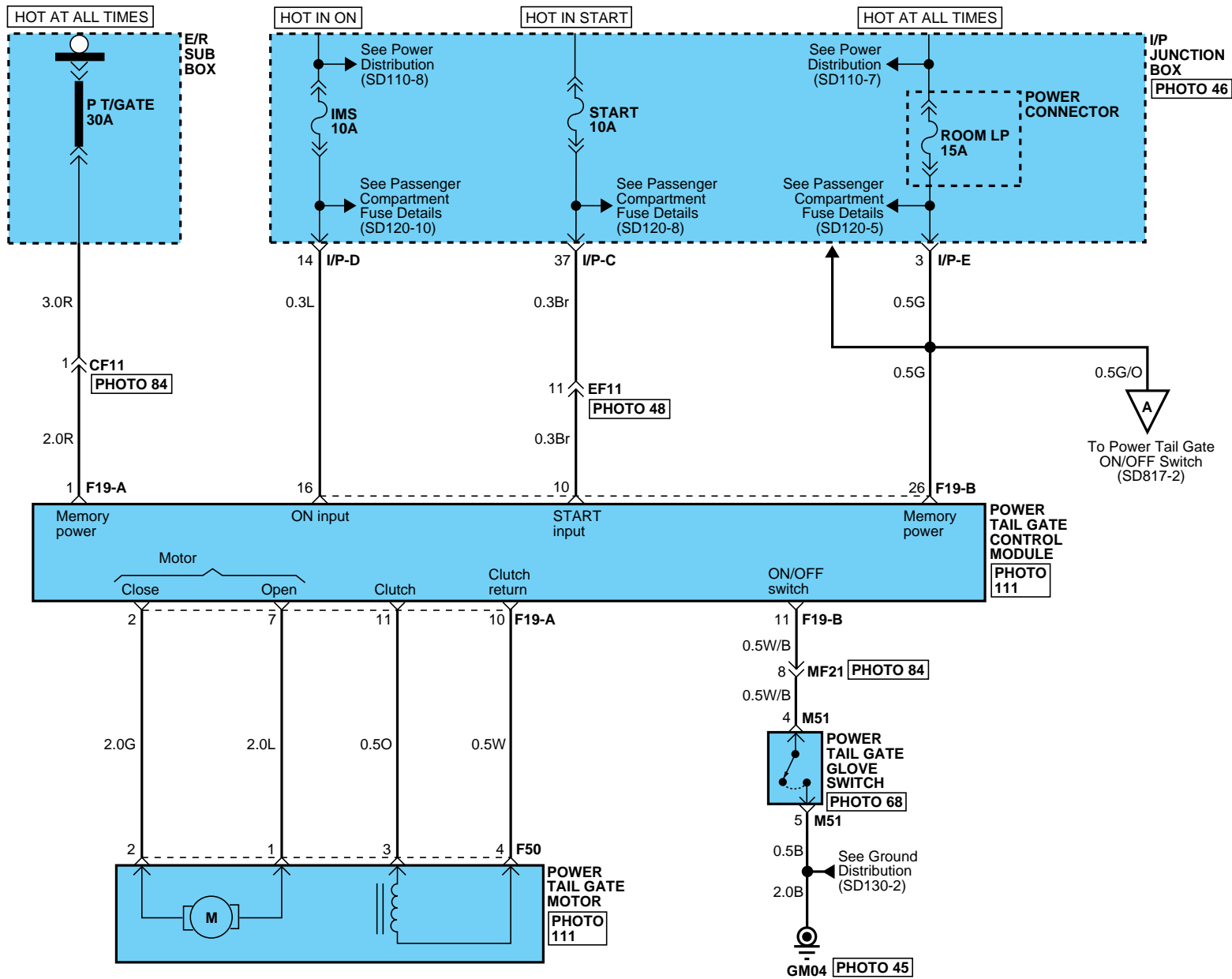

# POWER TAIL GATE SYSTEM

## Power Tail Gate System (2)

SD817-2

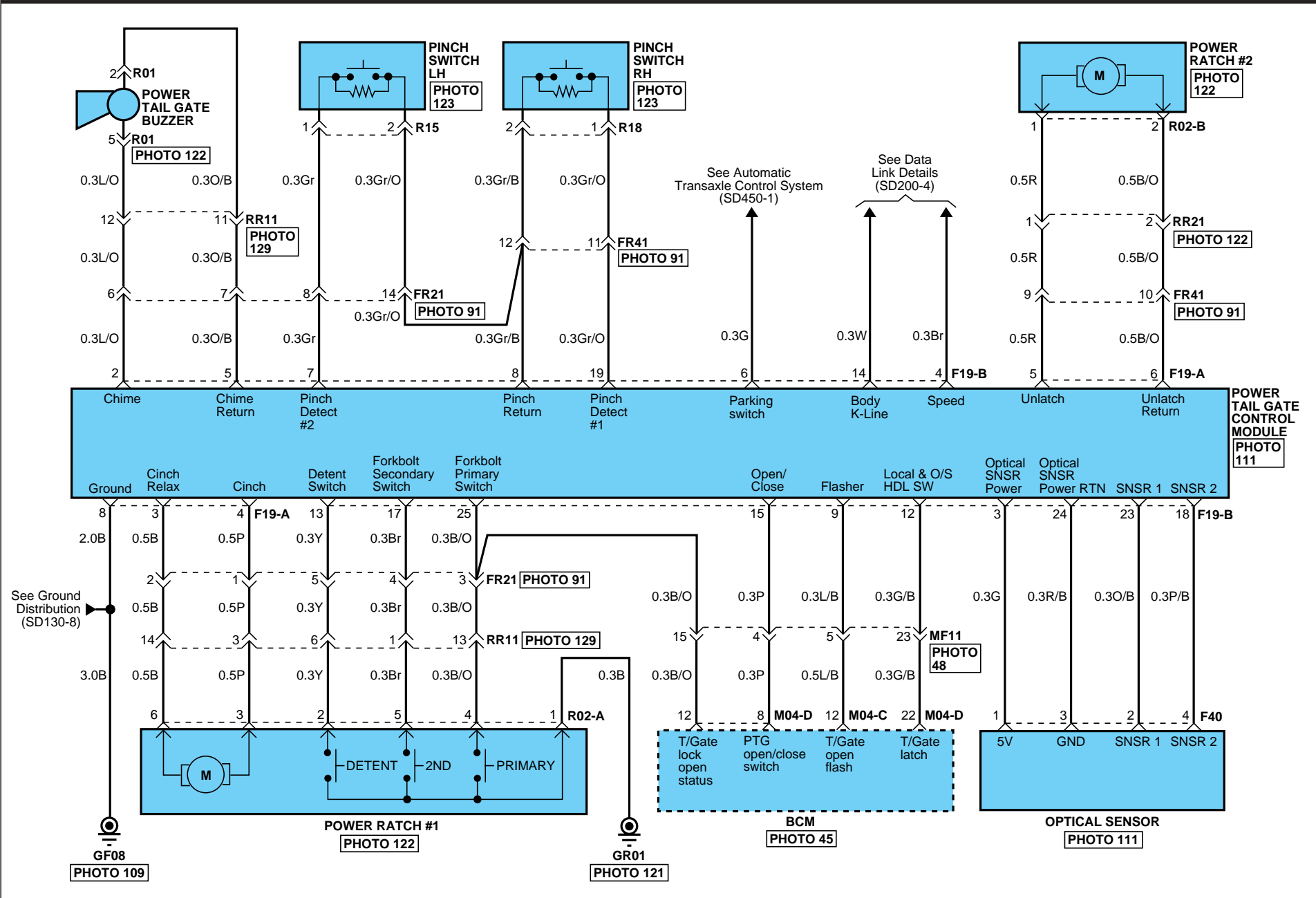

# POWER TAIL GATE SYSTEM

## Power Tail Gate System (3)

SD817-3

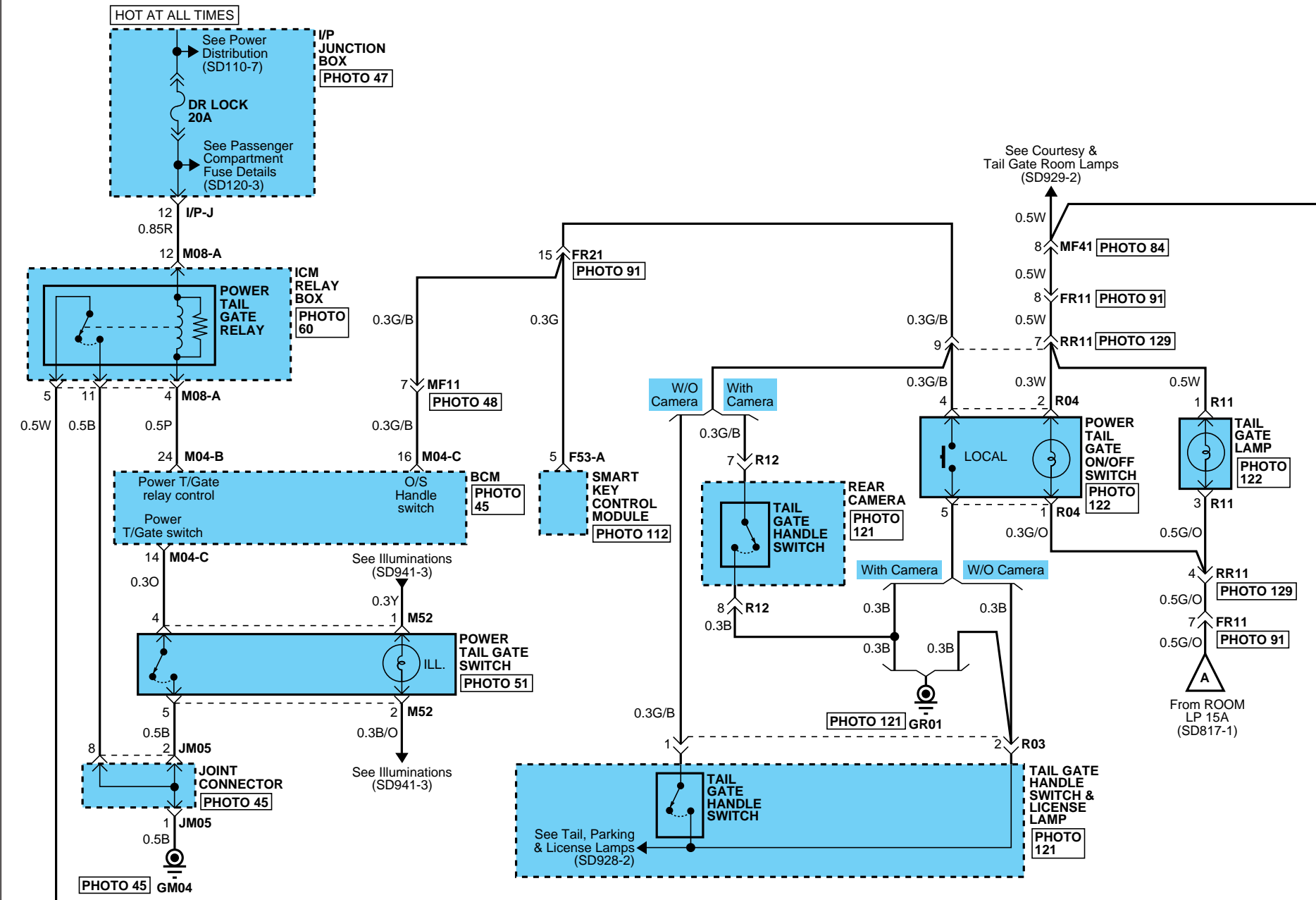

# POWER TAIL GATE SYSTEM

## Power Tail Gate System (4)

SD817-4

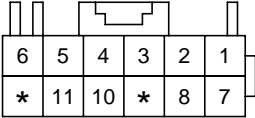
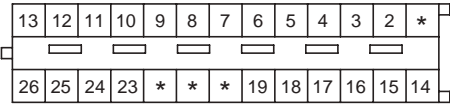
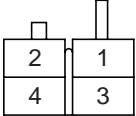
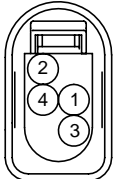
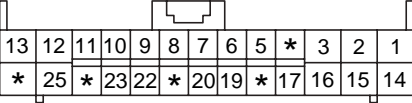
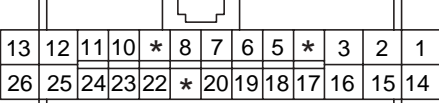
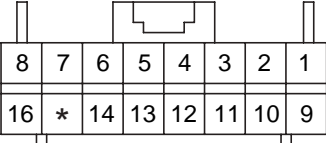
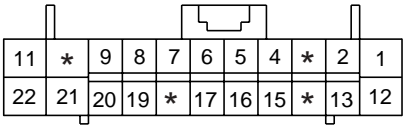
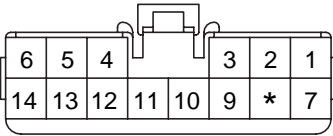
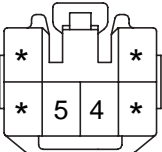
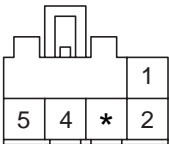
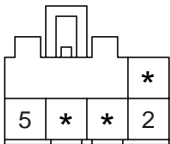
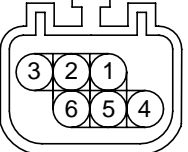
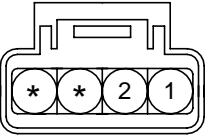
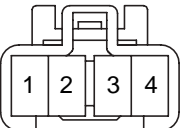
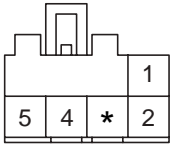
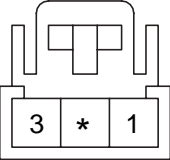
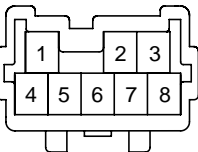
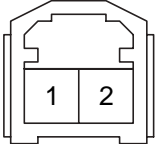
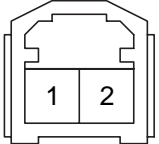
<p><b>F19-A</b></p>  <p>YAZ_110_12F_GR</p>	<p><b>F19-B</b></p>  <p>AMP_MQS_26F_B</p>	<p><b>F40</b></p>  <p>PKD_150_04F_B</p>	<p><b>F50</b></p>  <p>EPC_3507_04F_B</p>
<p><b>F53-A</b></p>  <p>AMP_0407_26F_W_HD</p>	<p><b>M04-B</b></p>  <p>AMP_0407_26F_Gr_HD</p>	<p><b>M04-C</b></p>  <p>AMP_0407_16F_W_040</p>	<p><b>M04-D</b></p>  <p>AMP_0407_22F_W_HD</p>
<p><b>M08-A</b></p>  <p>KET_090II_14F_W</p>	<p><b>M51</b></p>  <p>KET_090II_06F_W</p>	<p><b>M52</b></p>  <p>KUM_CDR_05F_W</p>	<p><b>R01</b></p>  <p>KUM_CDR_05F_W</p>
<p><b>R02-A</b></p>  <p>EPC_5651_06F_B</p>	<p><b>R02-B</b></p>  <p>EPC_3116_04F_B</p>	<p><b>R03</b></p>  <p>KET_090II_04M_W</p>	<p><b>R04</b></p>  <p>KUM_CDR_05F_W</p>
<p><b>R11</b></p>  <p>AMP_070_03F_W</p>	<p><b>R12</b></p>  <p>KET_070_8M_W</p>	<p><b>R15</b></p>  <p>AMP_070_02M_W</p>	<p><b>R18</b></p>  <p>AMP_070_02M_W</p>

Power Windows (1)

SD824-1

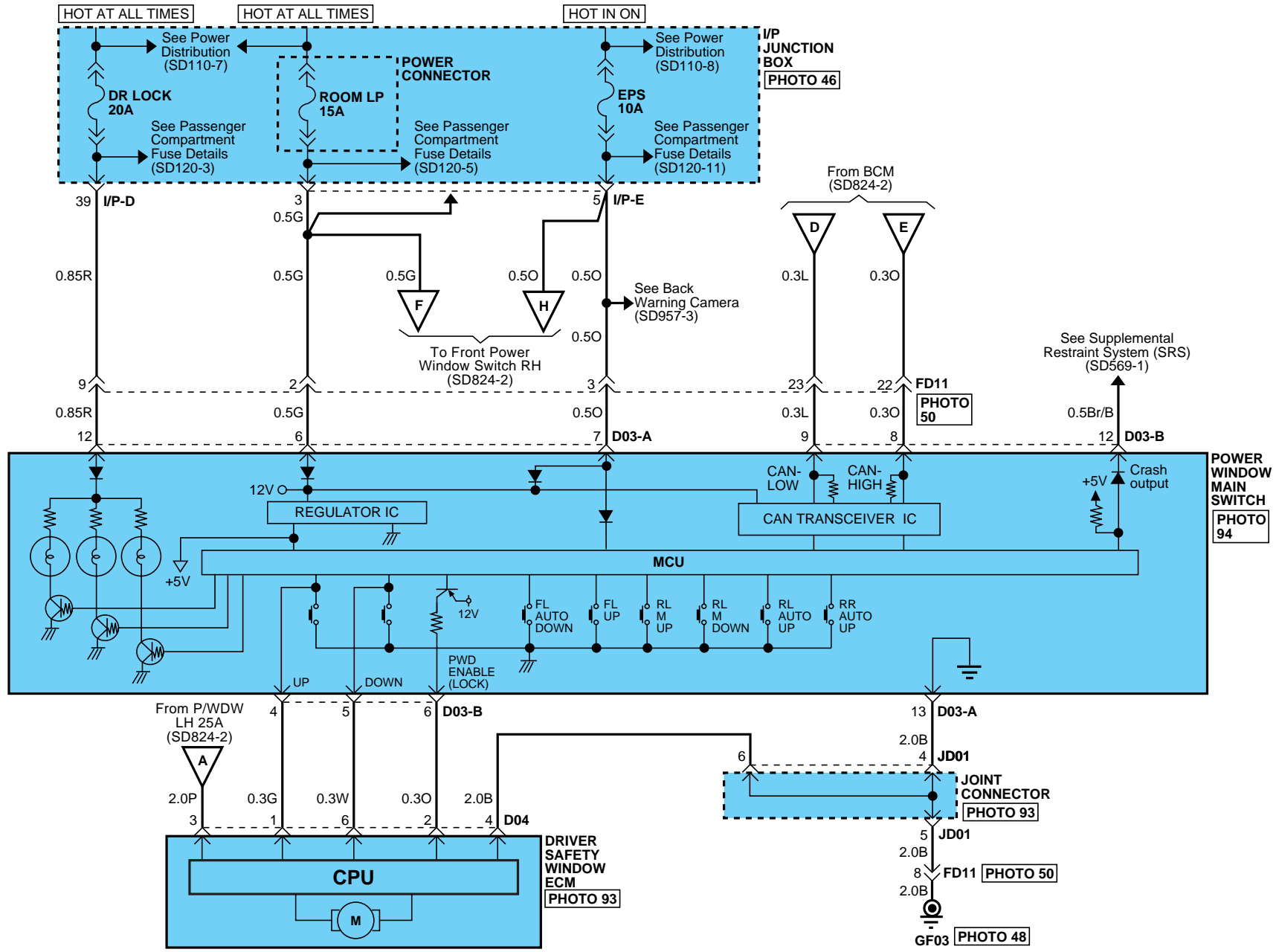





# POWER WINDOWS

## Power Windows (3)

SD824-3

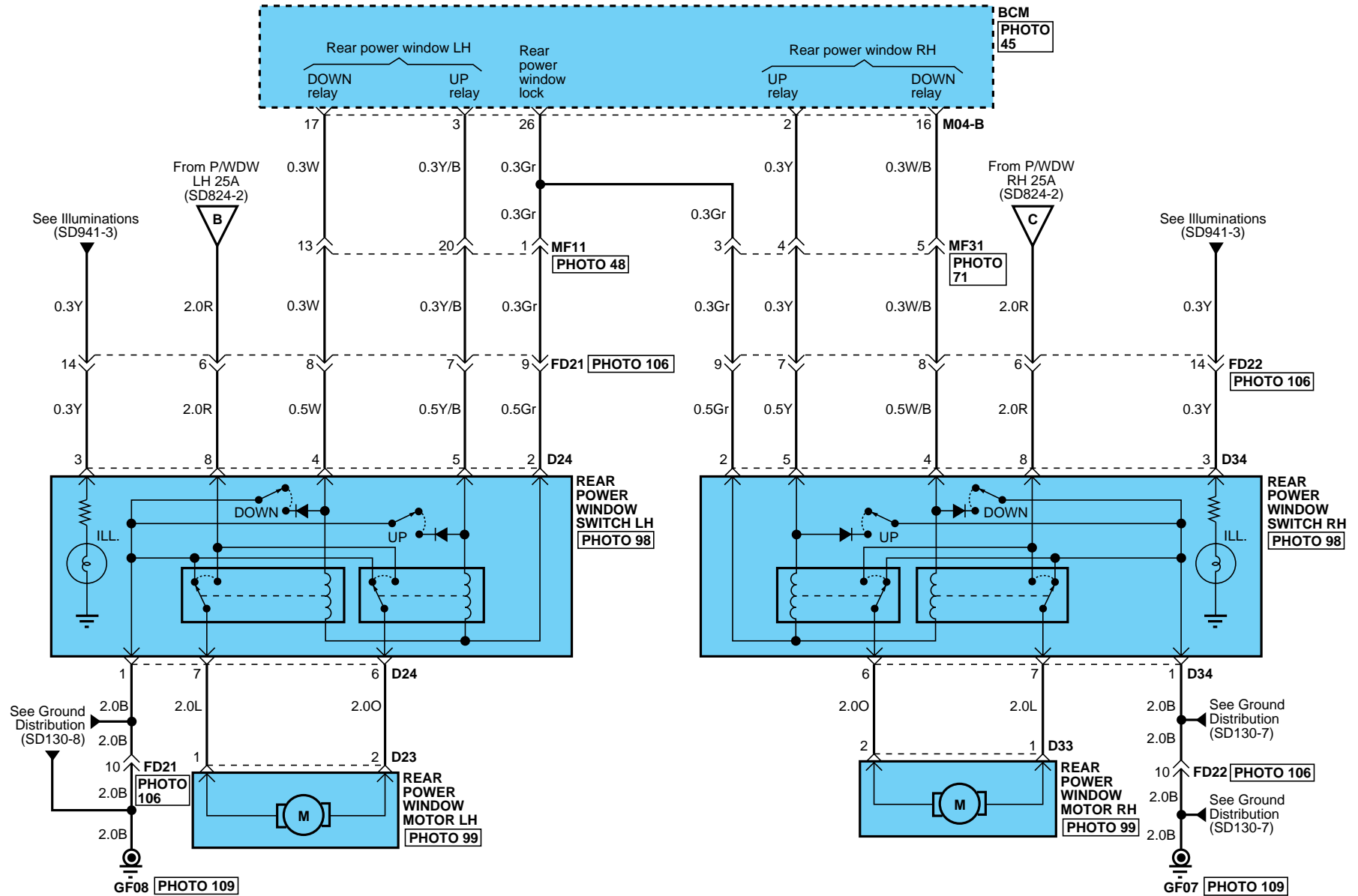

# POWER WINDOWS

## Power Windows (4)

SD824-4

**D03-A**

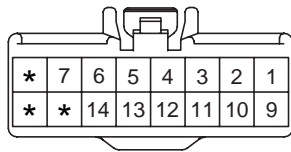

KET\_090III\_16F\_Y

**D03-B**

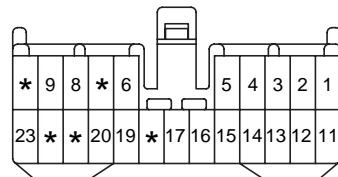

KET\_050\_23F\_W

**D04**

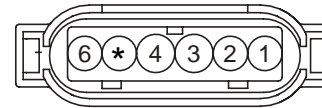

FCL\_SNSRECU\_06F\_B

**D14-A**

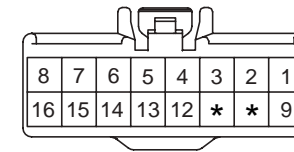

KET\_090III\_16F\_Y

**D14-B**

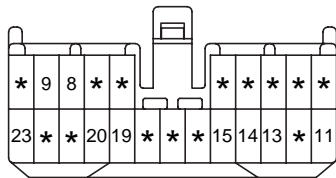

KET\_050\_23F\_W

**D17**

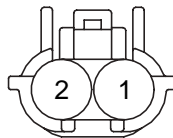

KET\_SWP\_02F\_B

**D23**

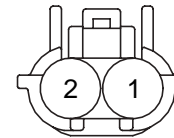

KET\_SWP\_02F\_B

**D24**

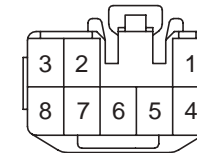

KET\_090III\_08F\_W

**D33**

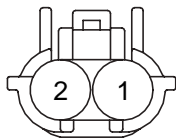

KET\_SWP\_02F\_B

**D34**

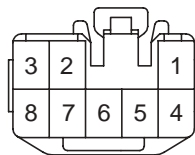

KET\_090III\_08F\_W

**M04-B**

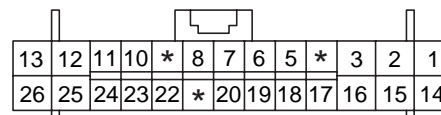

AMP\_0407\_26F\_Gr\_HD

**BLANK**

# ELECTRO CHROMIC MIRROR

E063142B

## Electro Chromic Mirror (1)

SD851-1

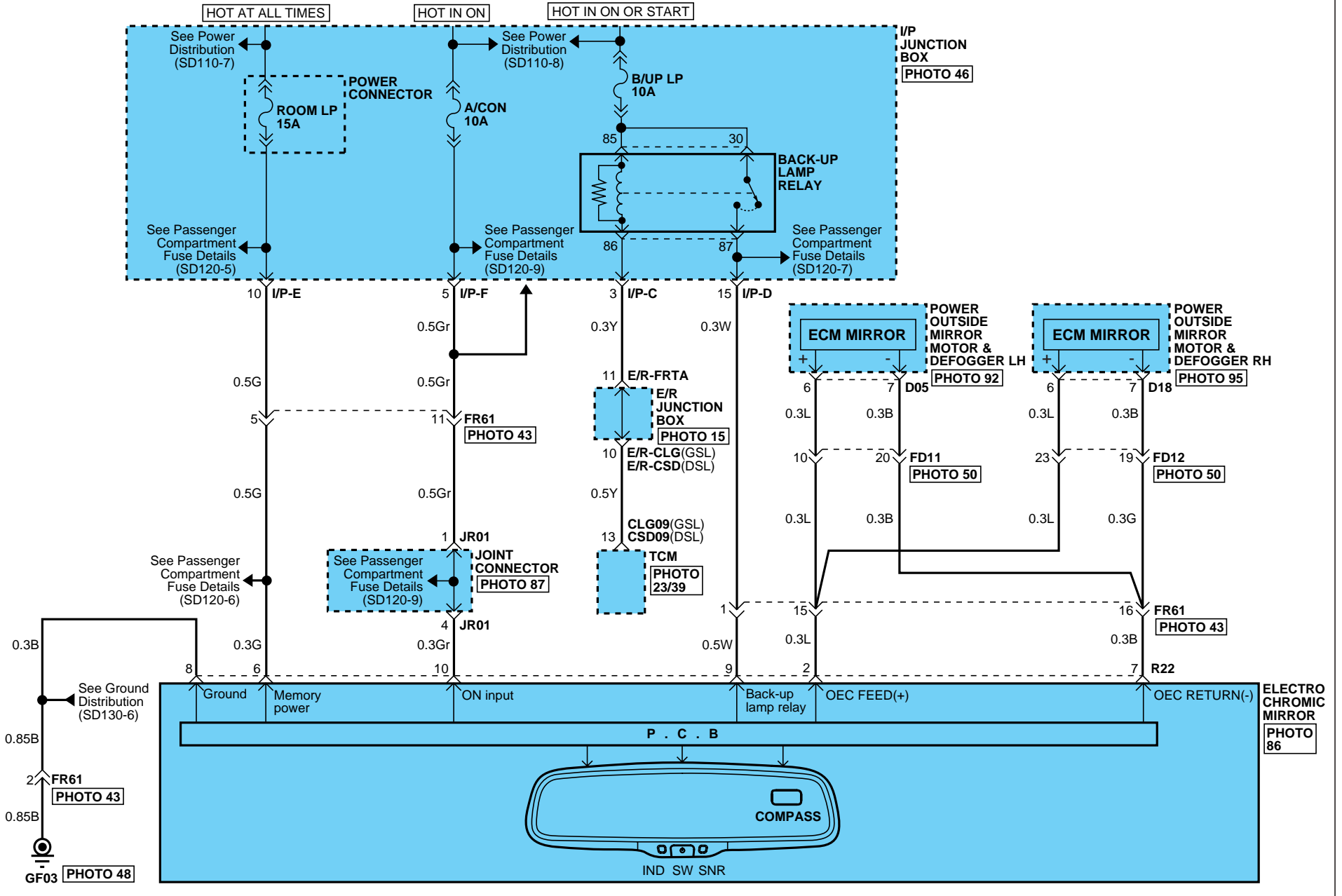

# ELECTRO CHROMIC MIRROR

## Electro Chromic Mirror (2)

SD851-2

**CLG09**

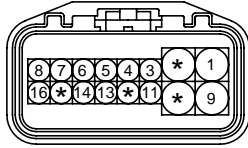

YAZ\_TCMWP\_16F\_B

**CSD09**

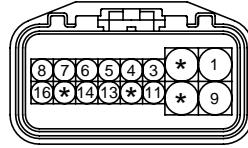

YAZ\_TCMWP\_16F\_B

**D05**

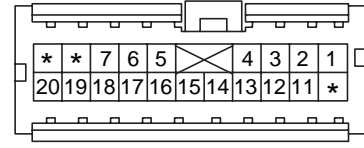

AMP\_040III\_20F\_W

**D18**

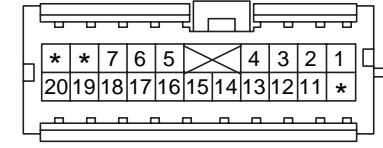

AMP\_040III\_20F\_W

**R22**

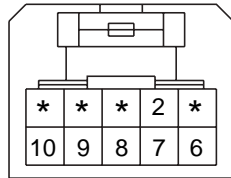

SUM\_025\_10F\_B

**BLANK**

**BLANK**

**BLANK**

Power Outside Mirror (1)

SD876-1

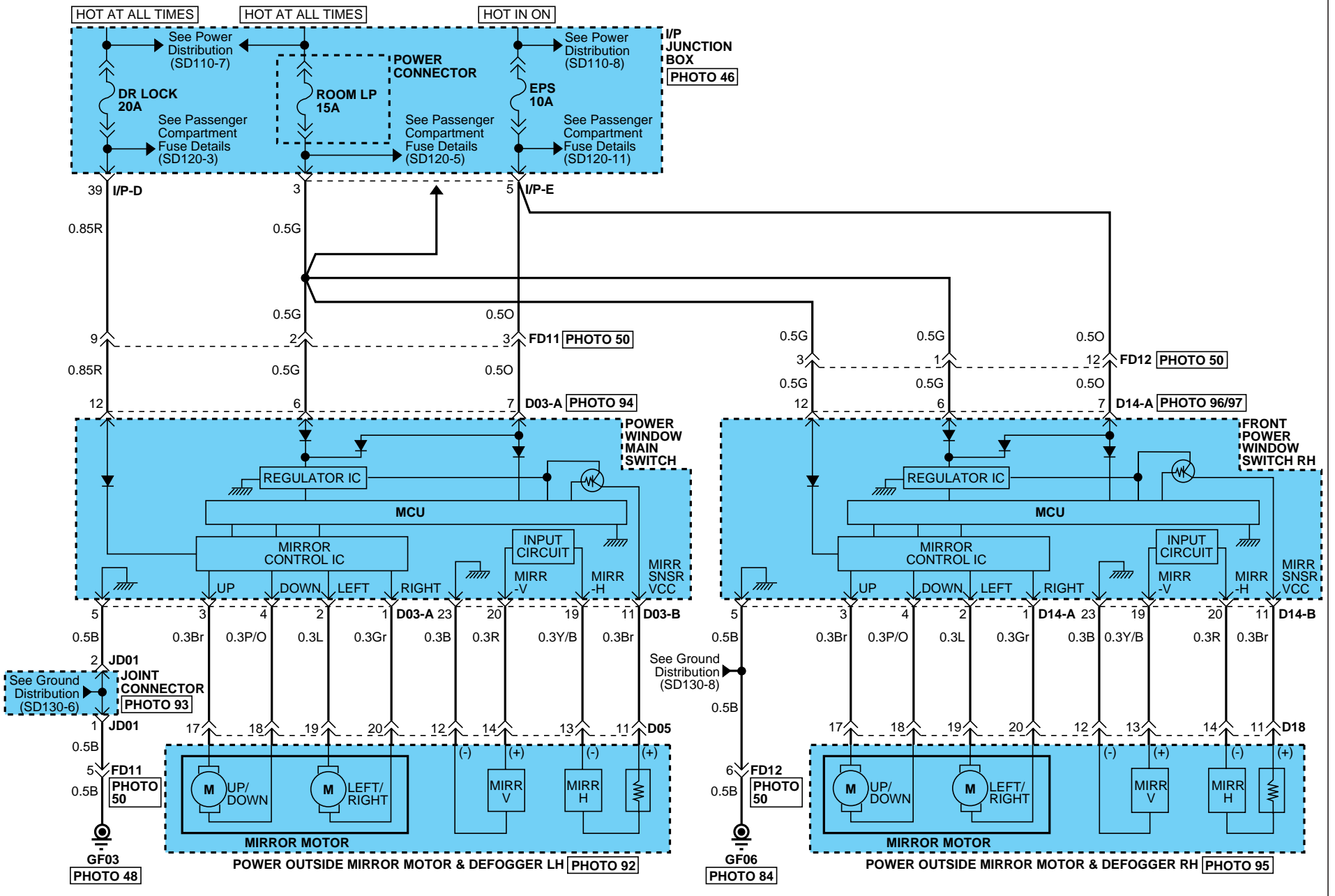

# POWER OUTSIDE MIRROR

## Power Outside Mirror (2)

SD876-2

**D03-A**

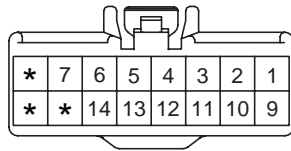

KET\_090III\_16F\_Y

**D03-B**

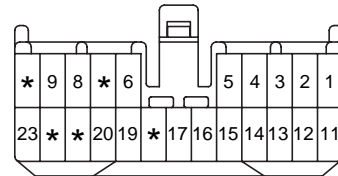

KET\_050\_23F\_W

**D05**

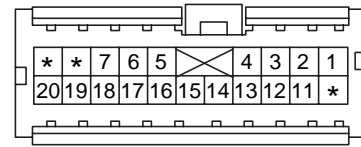

AMP\_040III\_20F\_W

**D14-A**

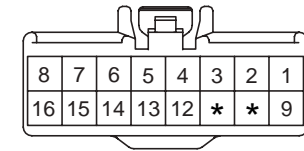

KET\_090III\_16F\_Y

**D14-B**

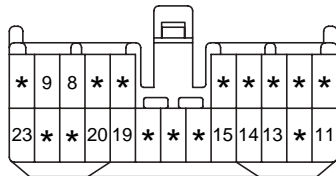

KET\_050\_23F\_W

**D18**

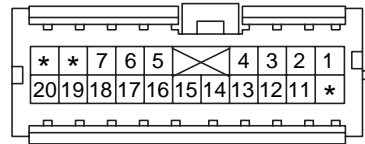

AMP\_040III\_20F\_W

**BLANK**

**BLANK**

Integrated Memory System (IMS) (1)

SD877-1

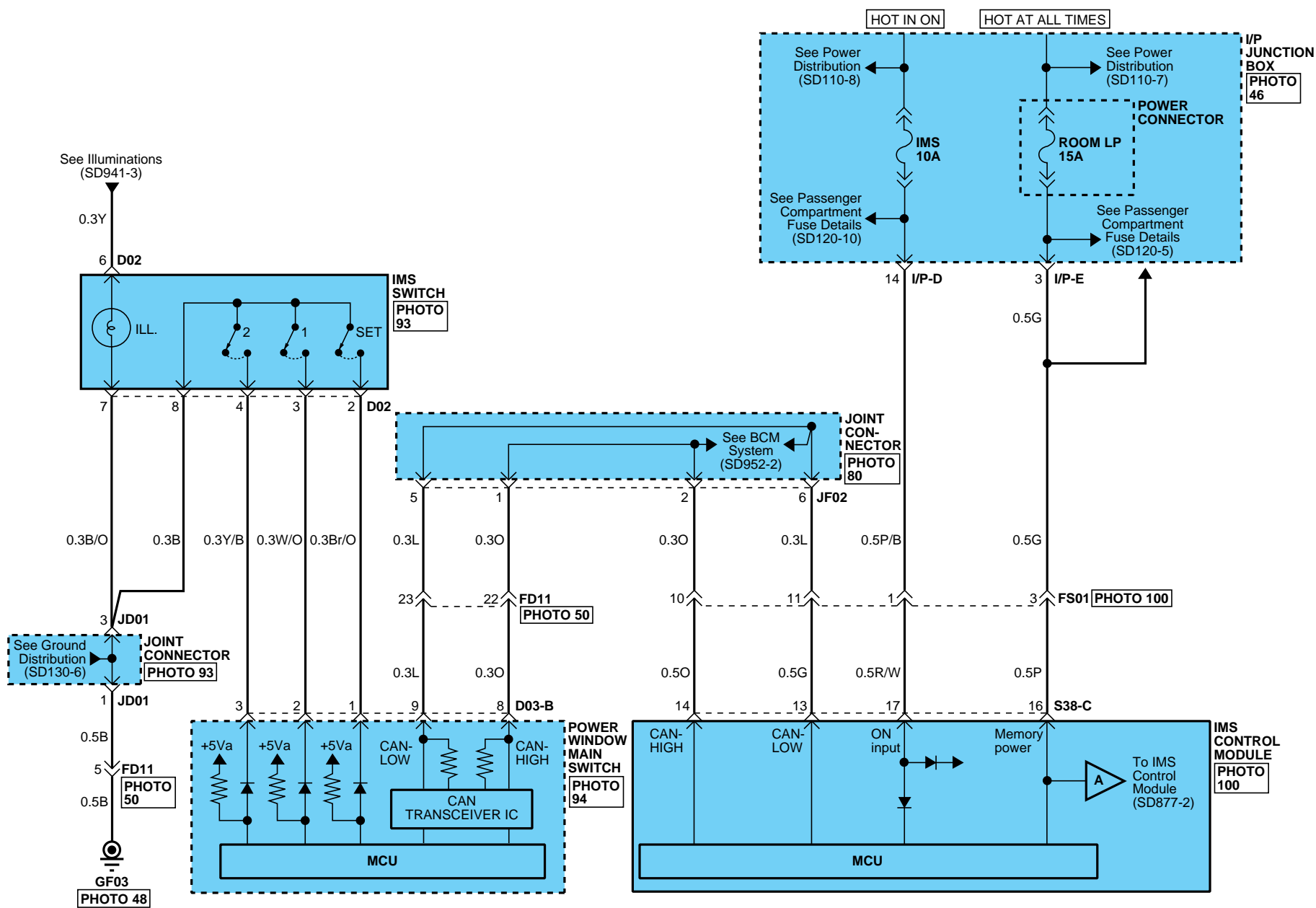





# INTEGRATED MEMORY SYSTEM (IMS)

## Integrated Memory System (IMS) (3)

SD877-3

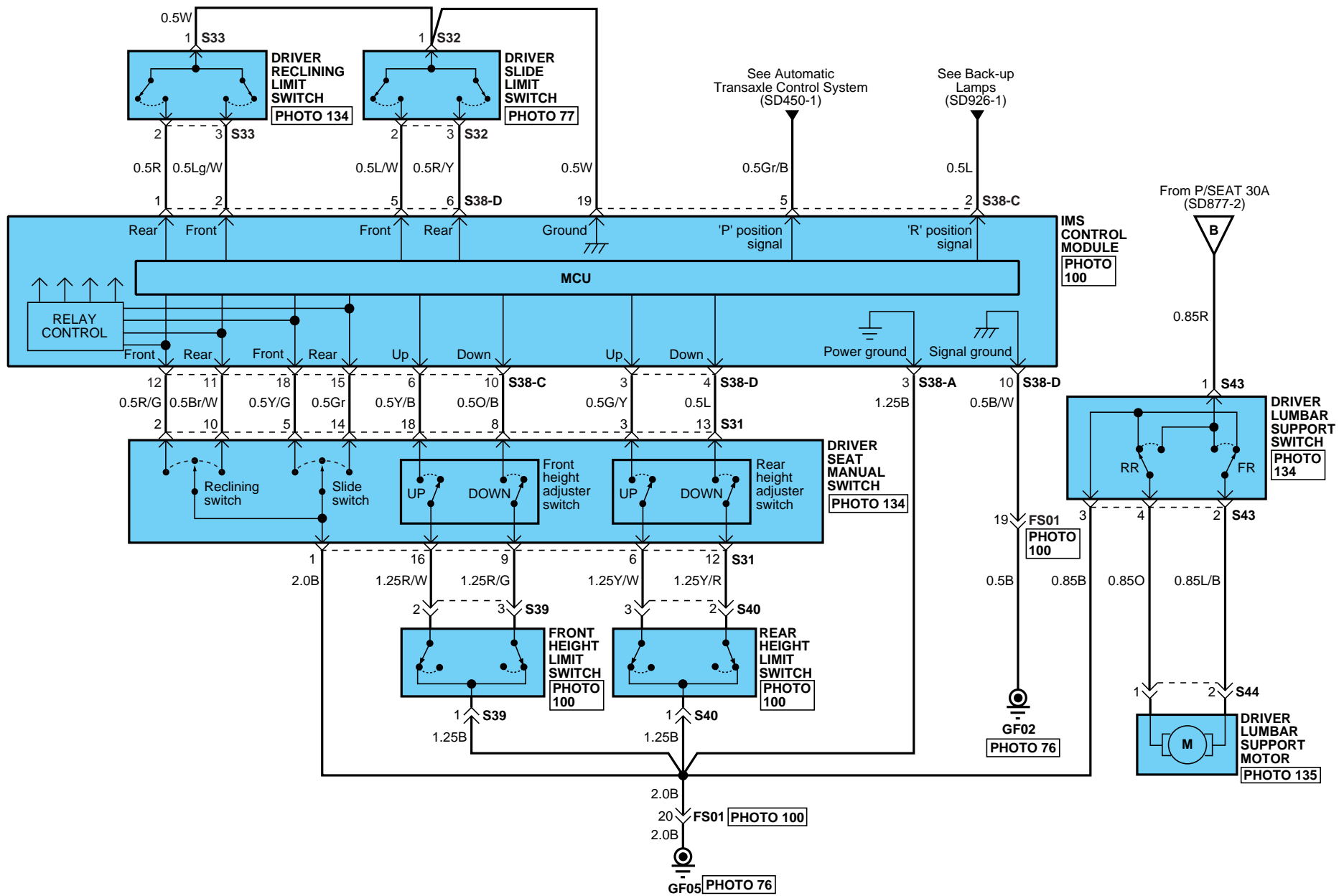

# INTEGRATED MEMORY SYSTEM (IMS)

Integrated Memory System (IMS) (4)			SD877-4
<p><b>D02</b></p> <p>KET_070_10F_W</p>	<p><b>D03-B</b></p> <p>KET_050_23F_W</p>	<p><b>S31</b></p> <p>CR18F016</p>	<p><b>S32</b></p> <p>CR03F005</p>
<p><b>S33</b></p> <p>CR03F005</p>	<p><b>S34</b></p> <p>CR06M016</p>	<p><b>S35</b></p> <p>CR06F014</p>	<p><b>S36</b></p> <p>CR06F060</p>
<p><b>S37</b></p> <p>CR06F060</p>	<p><b>S38-A</b></p> <p>CR04F018</p>	<p><b>S38-B</b></p> <p>CR08F004</p>	<p><b>S38-C</b></p> <p>CR20F021</p>
<p><b>S38-D</b></p> <p>CR16F017</p>	<p><b>S39</b></p> <p>CR03M017</p>	<p><b>S40</b></p> <p>CR03M017</p>	<p><b>S43</b></p> <p>CR04F007</p>
<p><b>S44</b></p> <p>CR02M012</p>	<p><b>BLANK</b></p>	<p><b>BLANK</b></p>	<p><b>BLANK</b></p>



# OUTSIDE MIRROR FOLDING

## Outside Mirror Folding (2)

SD878-2

**D03-A**

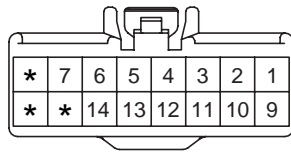

KET\_090III\_16F\_Y

**D14-A**

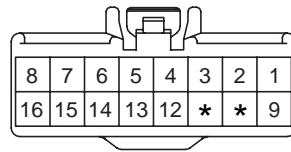

KET\_090III\_16F\_Y

**D05**

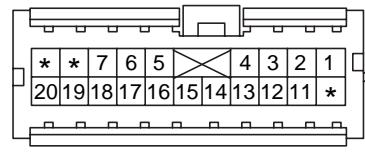

AMP\_040III\_20F\_W

**D18**

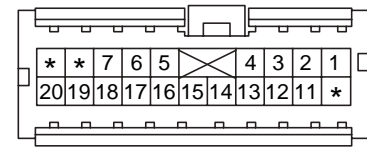

AMP\_040III\_20F\_W

Glass & Mirror Defogger (1)

SD879-1

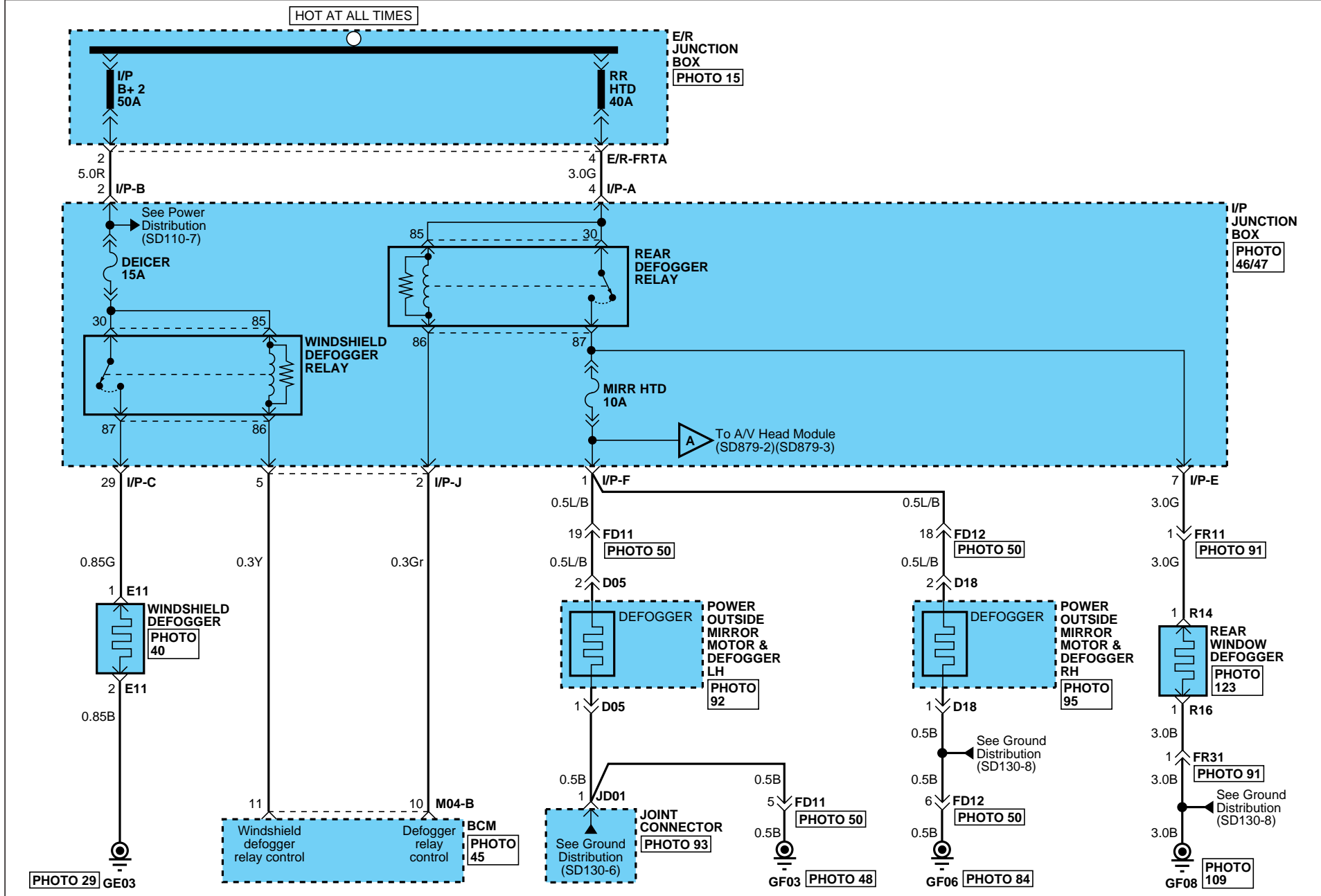



**MANUAL A/CON**

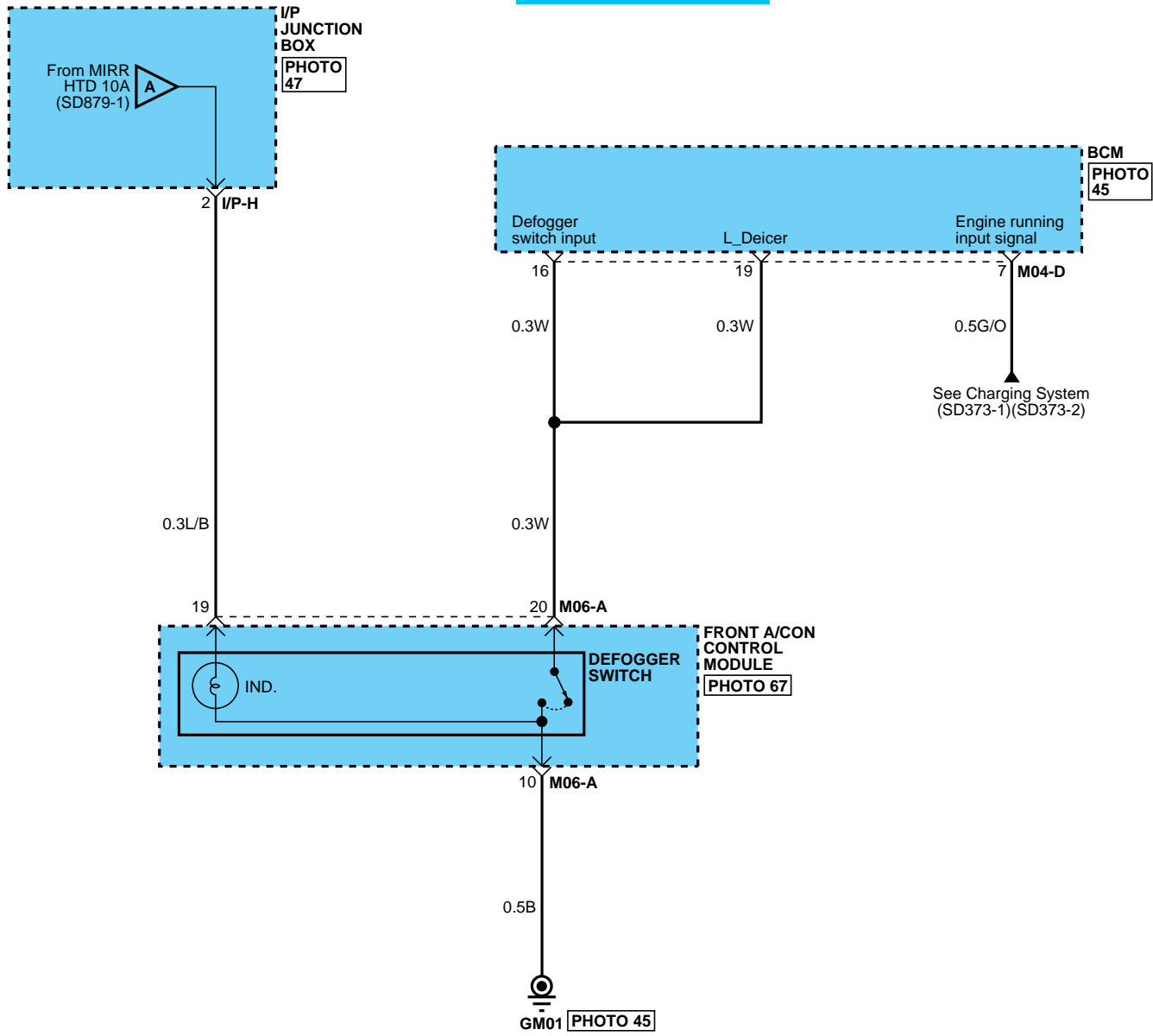

# GLASS & MIRROR DEFOGGER

## Glass & Mirror Defogger (4)

SD879-4

**D05**

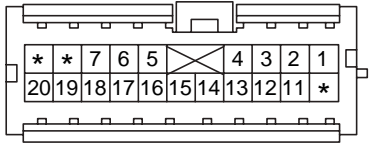

AMP\_040III\_20F\_W

**D18**

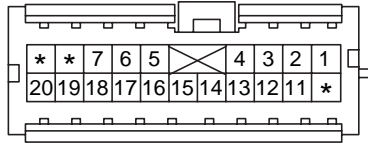

AMP\_040III\_20F\_W

**E11**

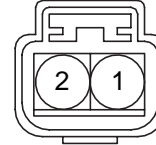

KUM\_NMWP\_02F\_B

**M04-B**

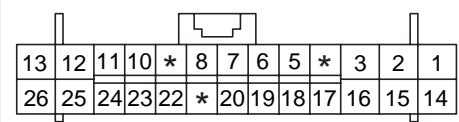

AMP\_0407\_26F\_Gr\_HD

**M04-D**

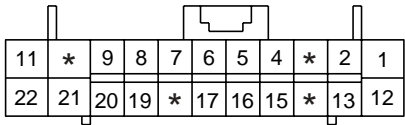

AMP\_0407\_22F\_W\_HD

**M05-A**

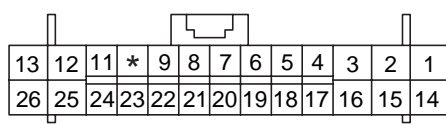

AMP\_0407\_26F\_W\_HD

**M06-A**

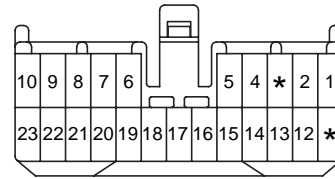

KET\_050\_23F\_W

**M21**

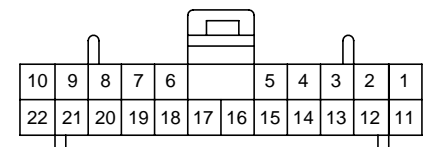

JAE\_040\_22F\_G

**M24-B**

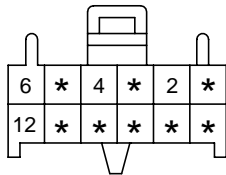

AMP\_DLI\_12F\_B

**M42**

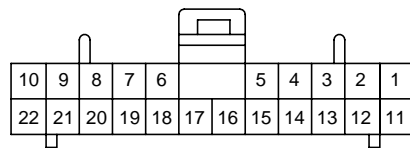

JAE\_040\_22F\_G

**R14**

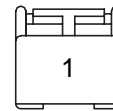

AMP\_PLM2\_01F\_B

**R16**

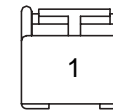

AMP\_PLM2\_01F\_B



Driver Power Seat (1)

SD880-1

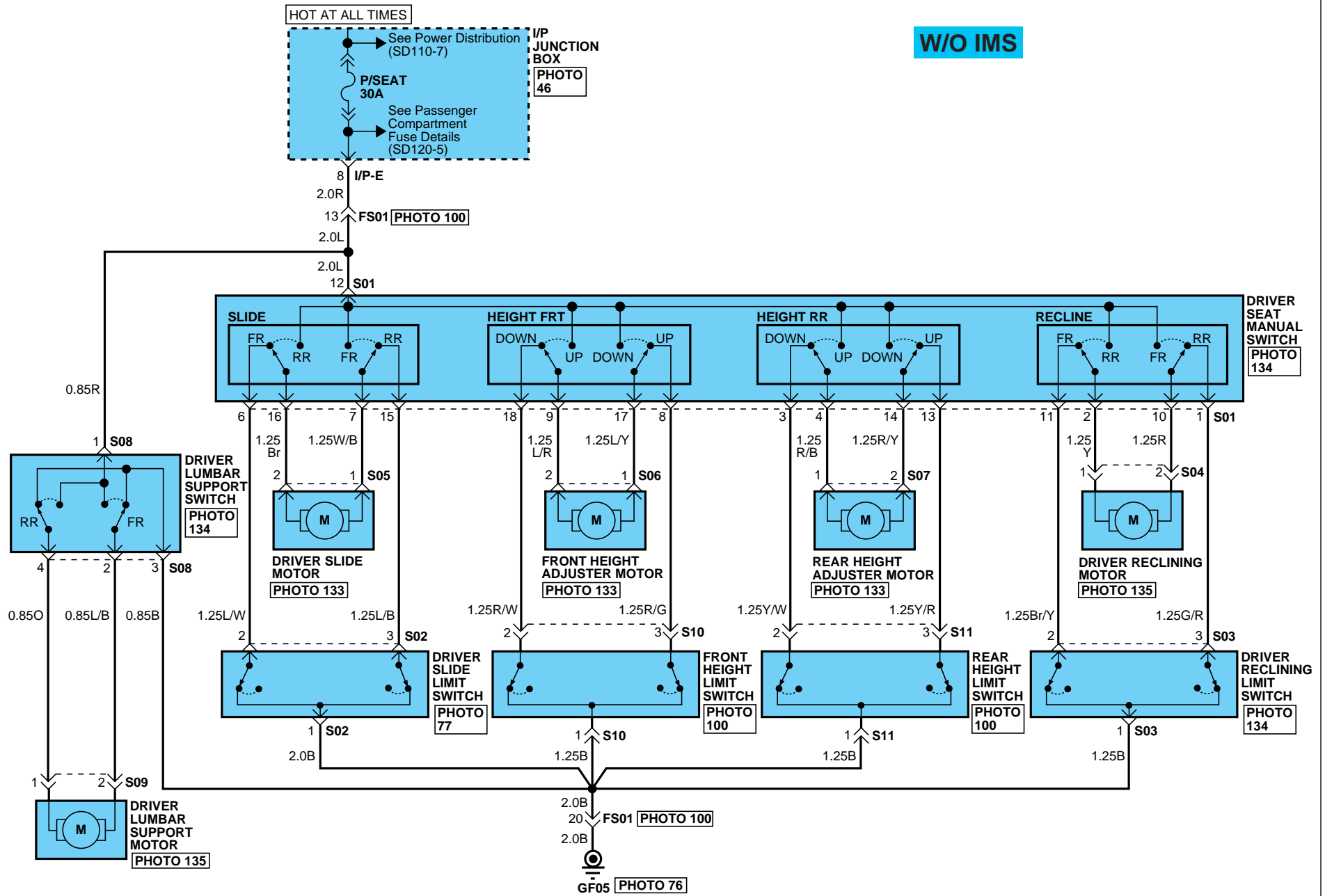

W/O IMS



**DRIVER POWER SEAT**

**Driver Power Seat (2)**

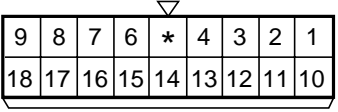
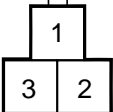
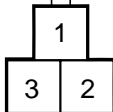
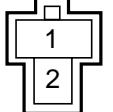
**SD880-2**

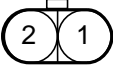
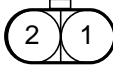
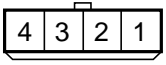
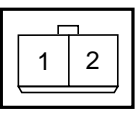
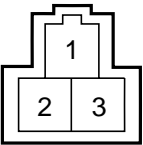
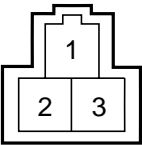
<p style="text-align: center;"><b>S01</b></p>  <p style="text-align: right; font-size: small;">CR18F016</p>	<p style="text-align: center;"><b>S02</b></p>  <p style="text-align: right; font-size: small;">CR03F005</p>	<p style="text-align: center;"><b>S03</b></p>  <p style="text-align: right; font-size: small;">CR03F005</p>	<p style="text-align: center;"><b>S04</b></p>  <p style="text-align: right; font-size: small;">CR02M056</p>
<p style="text-align: center;"><b>S05</b></p>  <p style="text-align: right; font-size: small;">CR02F012</p>	<p style="text-align: center;"><b>S06</b></p>  <p style="text-align: right; font-size: small;">CR02F025</p>	<p style="text-align: center;"><b>S07</b></p>  <p style="text-align: right; font-size: small;">CR02F025</p>	<p style="text-align: center;"><b>S08</b></p>  <p style="text-align: right; font-size: small;">CR04F007</p>
<p style="text-align: center;"><b>S09</b></p>  <p style="text-align: right; font-size: small;">CR02M018</p>	<p style="text-align: center;"><b>S10</b></p>  <p style="text-align: right; font-size: small;">CR03M017</p>	<p style="text-align: center;"><b>S11</b></p>  <p style="text-align: right; font-size: small;">CR03M017</p>	<p style="text-align: center;"><b>BLANK</b></p>

# PASSENGER POWER SEAT

E4A954F7

## Passenger Power Seat (1)

SD881-1

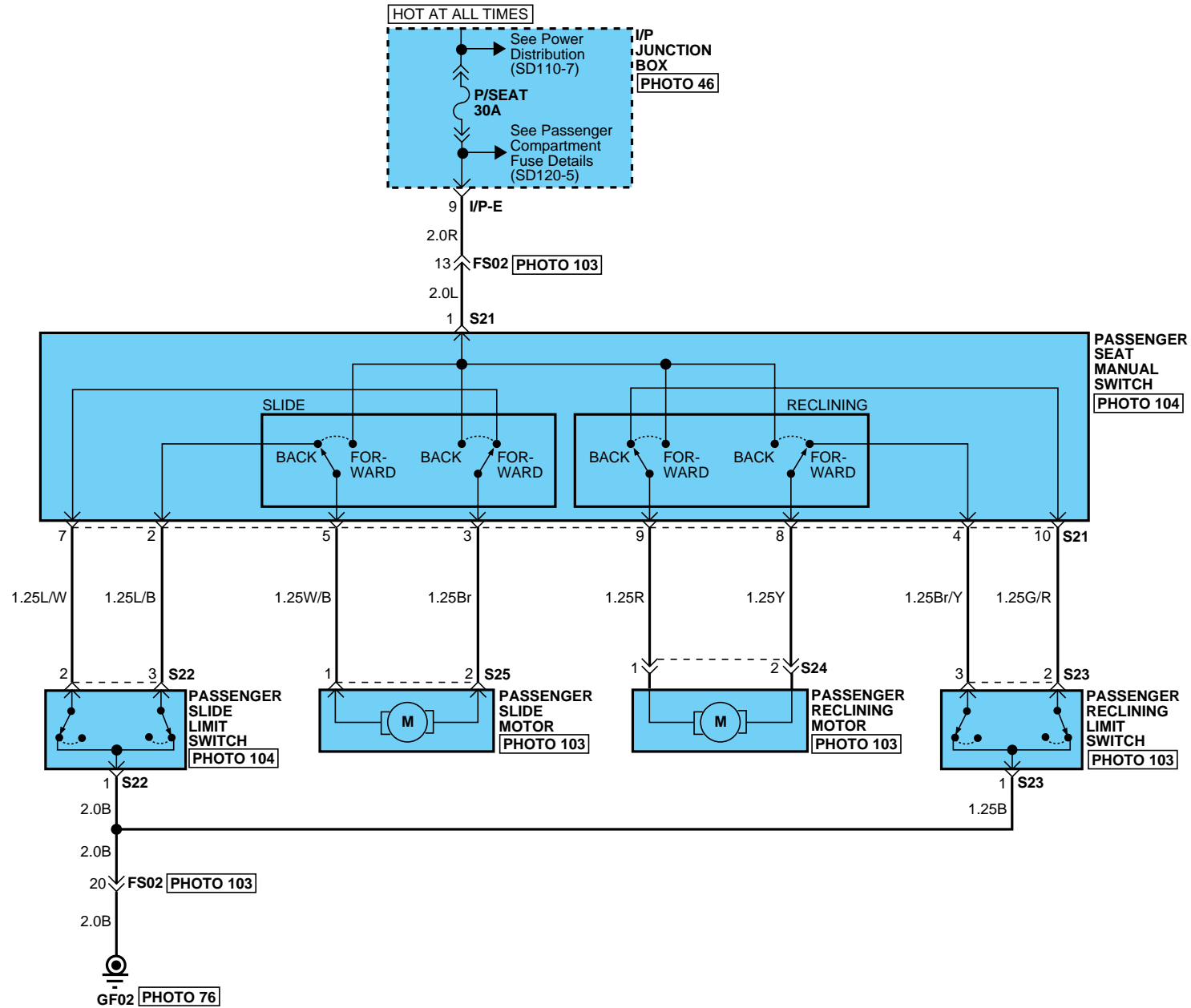

# PASSENGER POWER SEAT

## Passenger Power Seat (2)

SD881-2

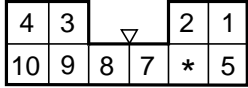
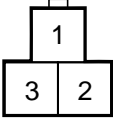
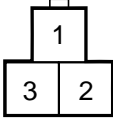
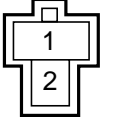
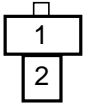
S21	S22	S23	S24
 <p>CR10F015</p>	 <p>CR03F005</p>	 <p>CR03F005</p>	 <p>CR02M056</p>
 <p>CR02F012</p>	<p>BLANK</p>	<p>BLANK</p>	<p>BLANK</p>

Adjustable Seat Warmer System (1)

SD885-1

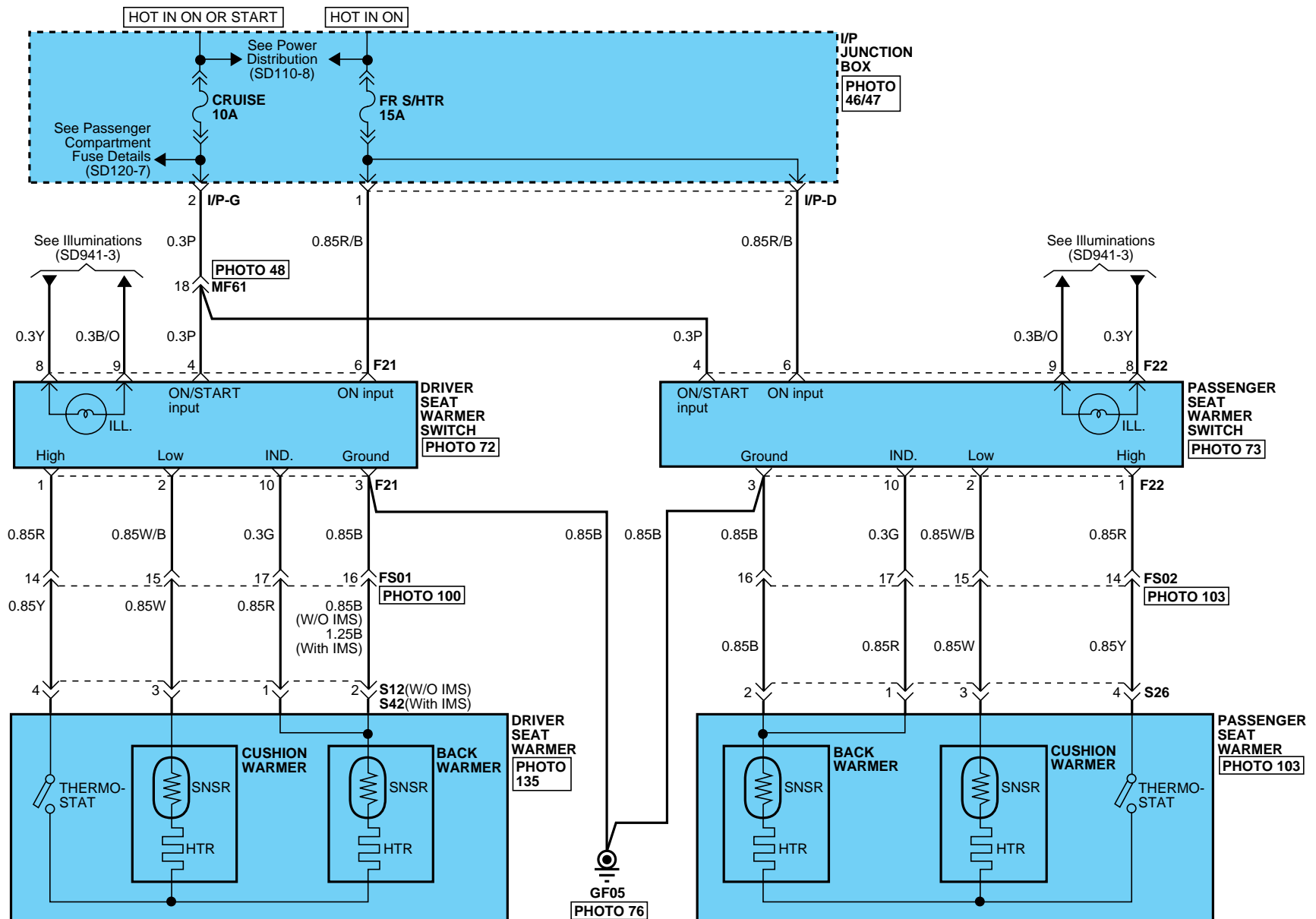

# ADJUSTABLE SEAT WARMER SYSTEM

## Adjustable Seat Warmer System (2)

SD885-2

**WITH REAR A/CON  
(EXCEPT EURO)**

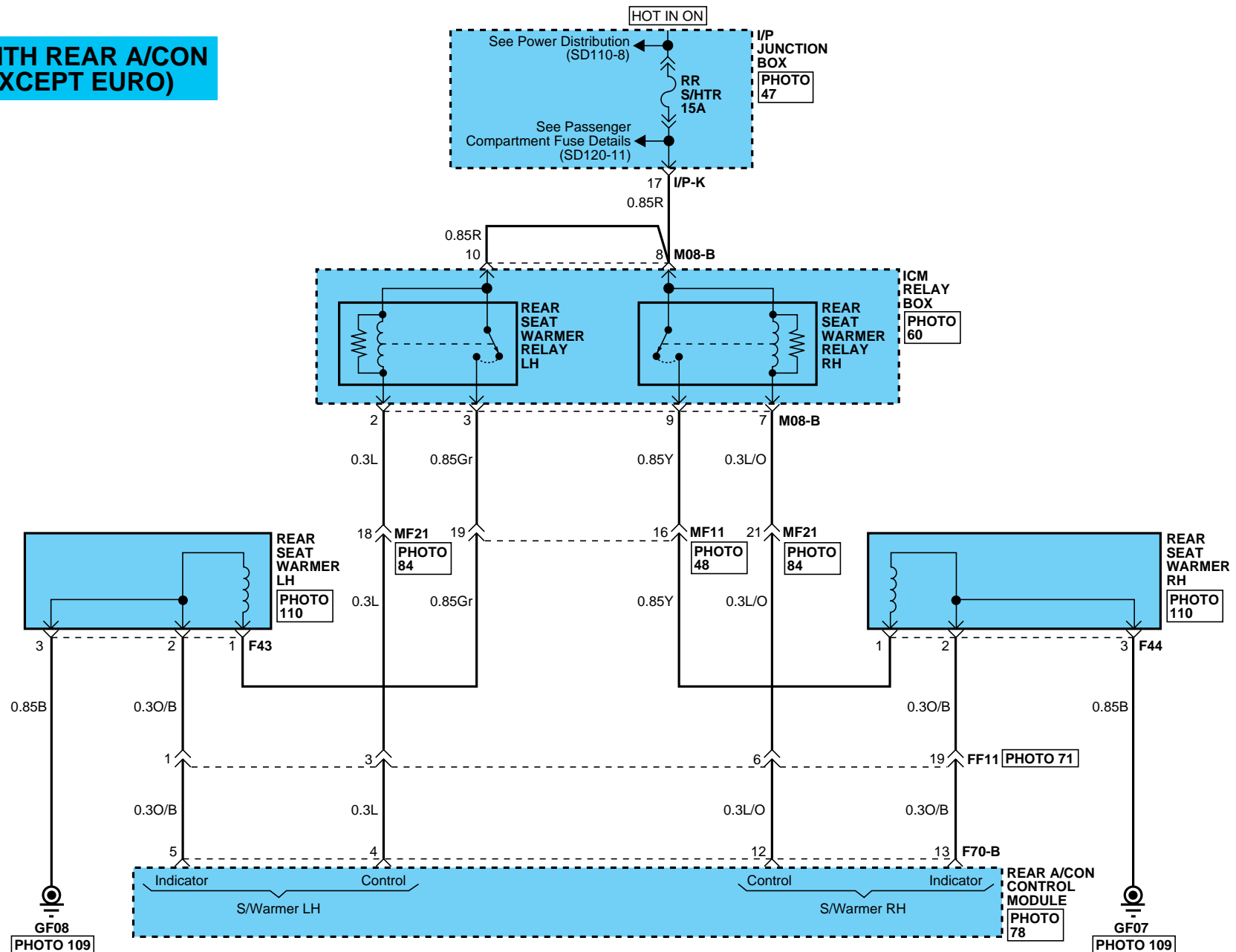

# ADJUSTABLE SEAT WARMER SYSTEM

## Adjustable Seat Warmer System (3)

SD885-3

**WITH REAR A/CON  
(EURO)**

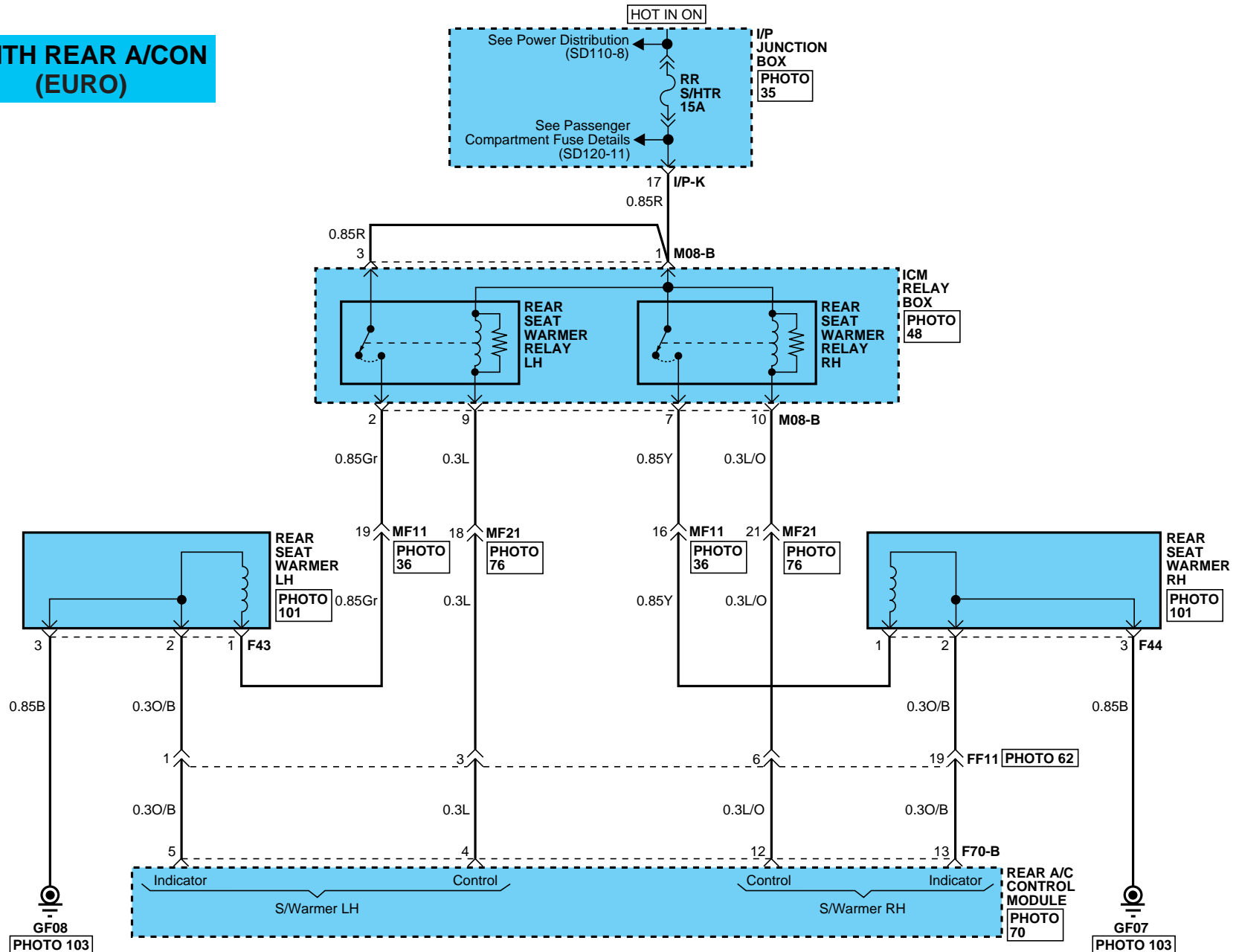

# ADJUSTABLE SEAT WARMER SYSTEM

## Adjustable Seat Warmer System (4)

SD885-4

**W/O REAR A/CON**

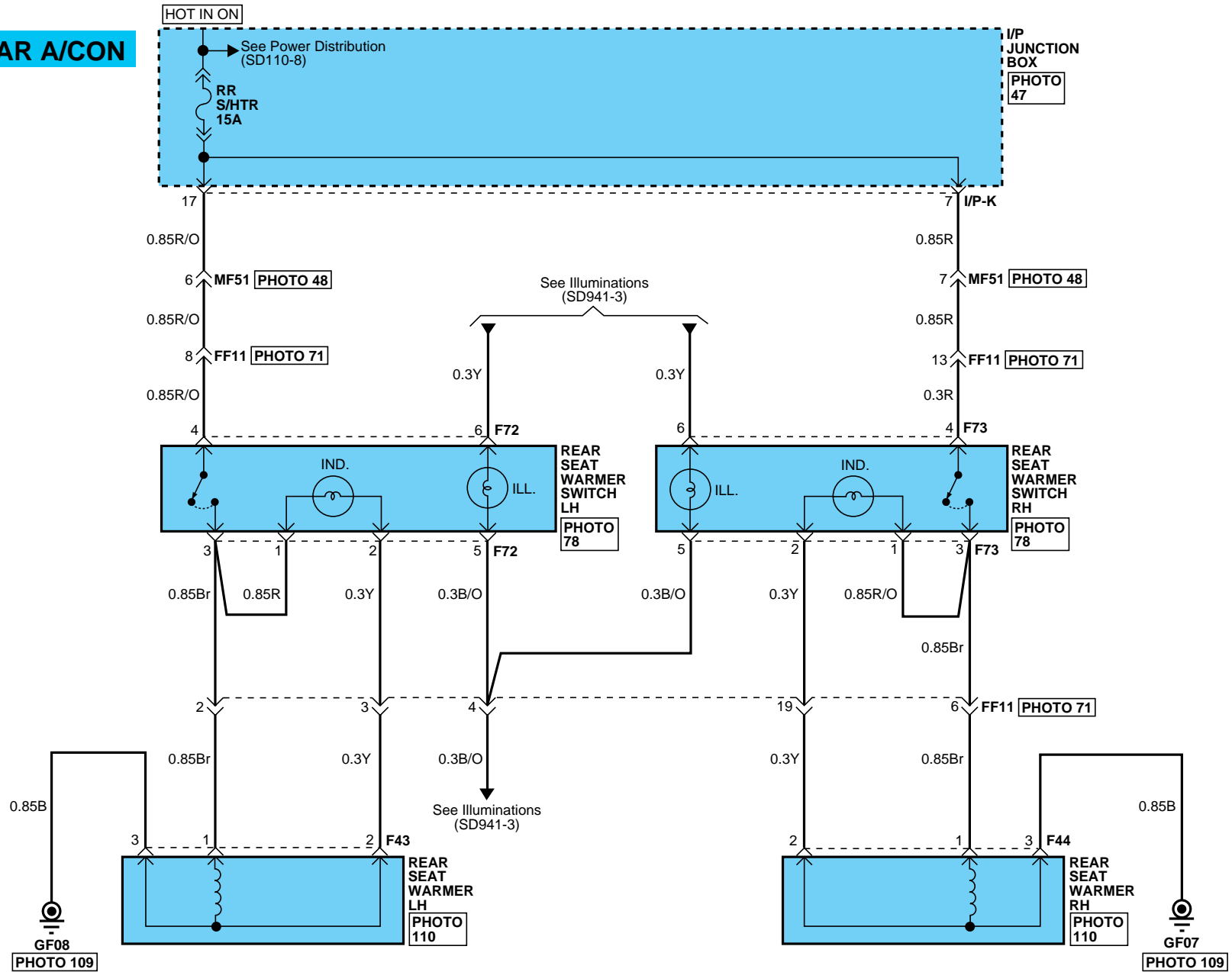



# ADJUSTABLE SEAT WARMER SYSTEM

## Adjustable Seat Warmer System (5)

SD885-5

**F21**

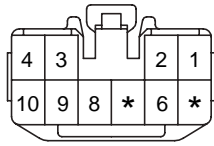

KET\_090II\_10F\_W\_SW

**F22**

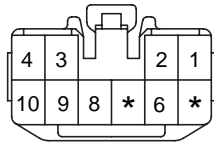

KET\_090II\_10F\_Y\_SW

**F43**

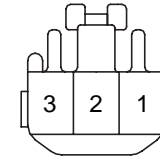

KET\_090II\_03F\_W

**F44**

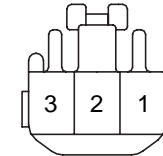

KET\_090II\_03F\_W

**F70-B**

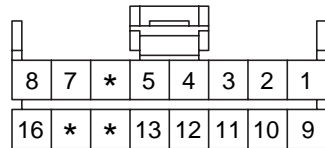

AMP\_040M1\_16F\_B

**F72**

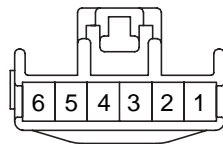

KET\_090II\_06F\_W

**F73**

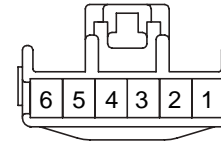

KET\_090II\_06F\_W

**M08-B**

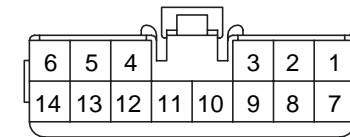

KET\_090II\_14F\_B

**S12**

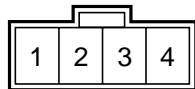

CR04M040

**S26**

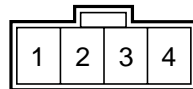

CR04M040

**S42**

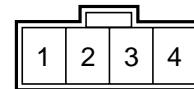

CR04M040

**BLANK**

**ADJUSTABLE SEAT WARMER SYSTEM**

**Adjustable Seat Warmer System (6)**

**SD885-6**

**MEMO**

Head Lamps (1)

SD921-1

WITH DRL

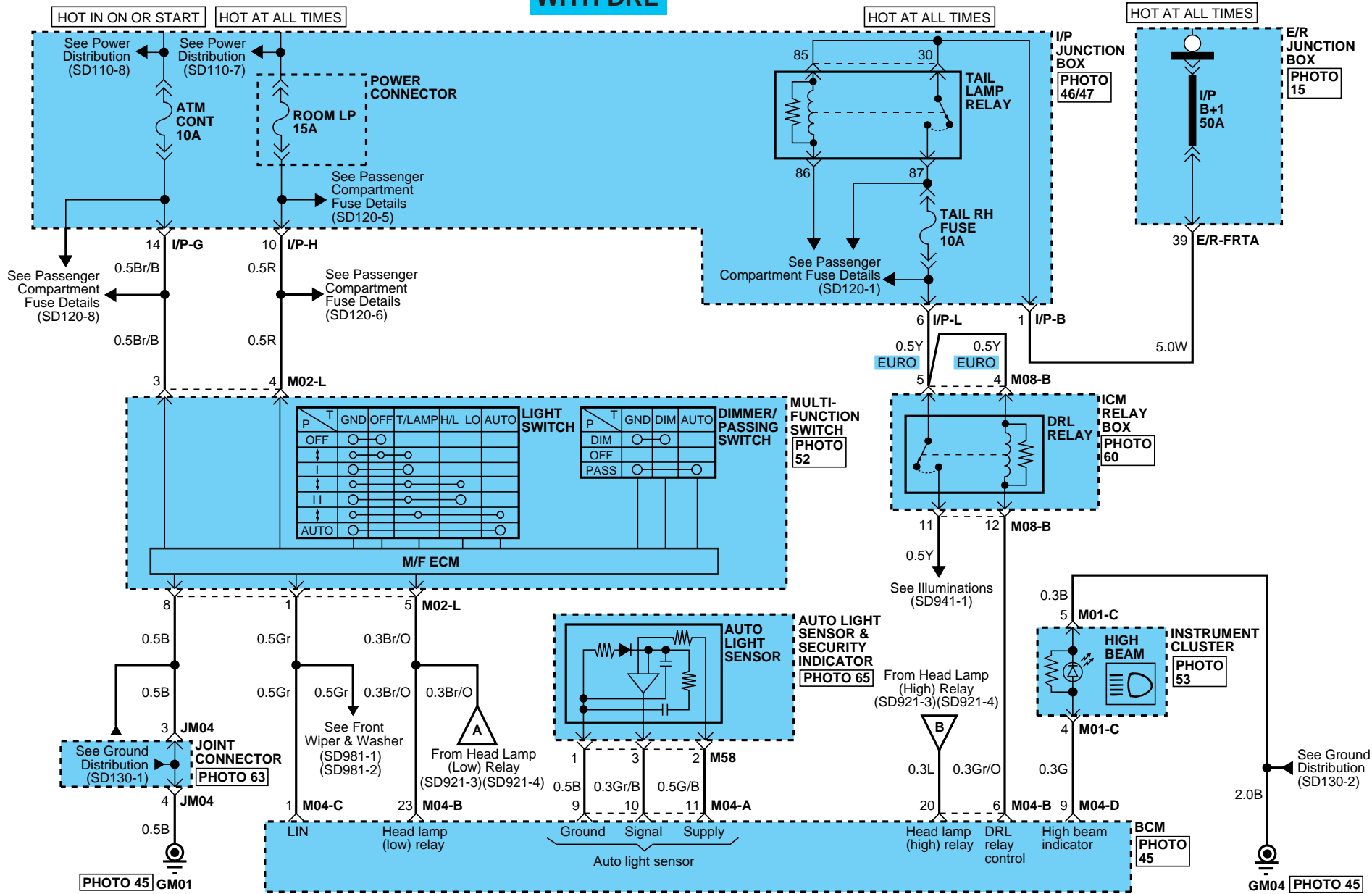

# HEAD LAMPS

## Head Lamps (2)

SD921-2

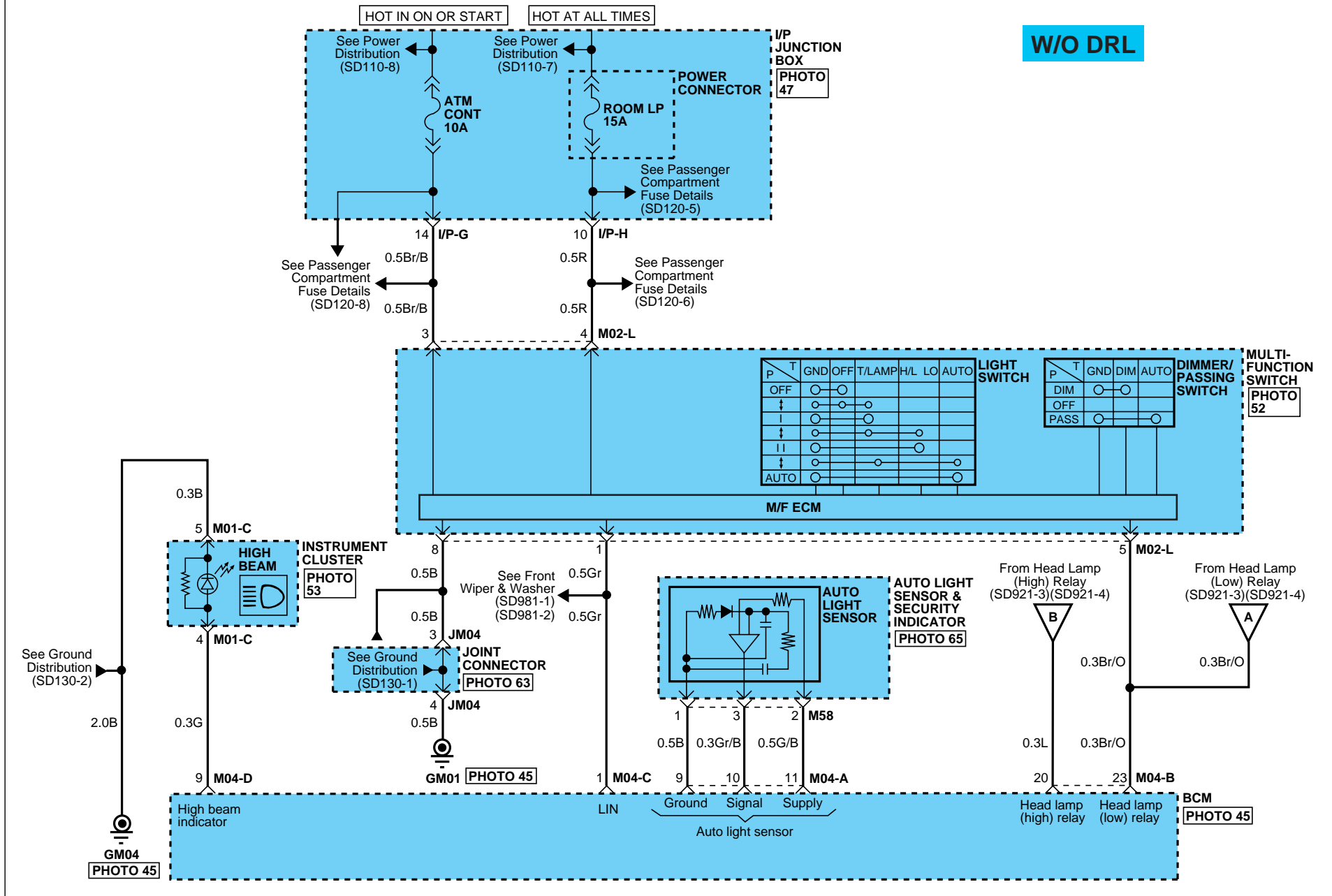

# HEAD LAMPS

## Head Lamps (3)

SD921-3

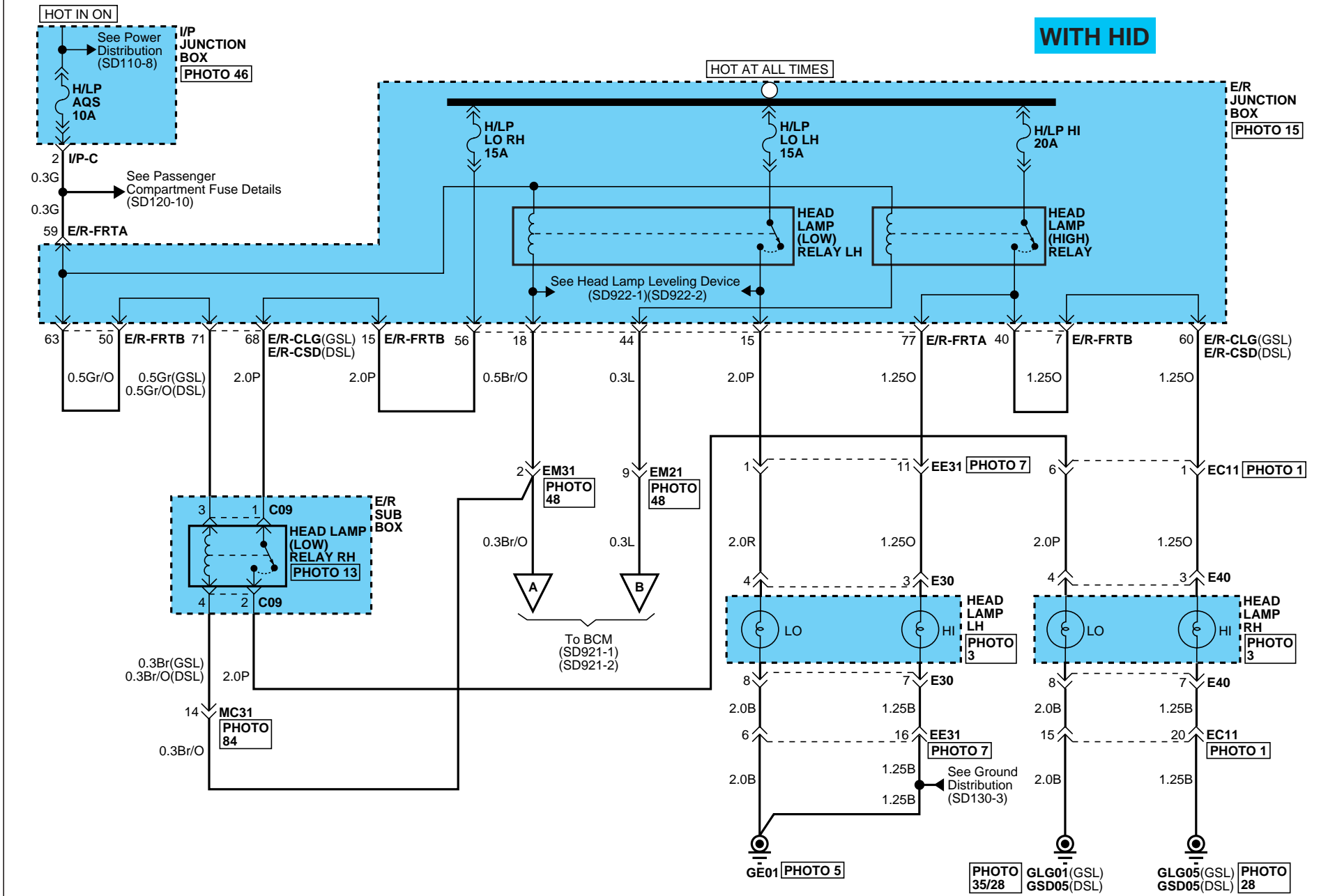

# HEAD LAMPS

## Head Lamps (4)

SD921-4

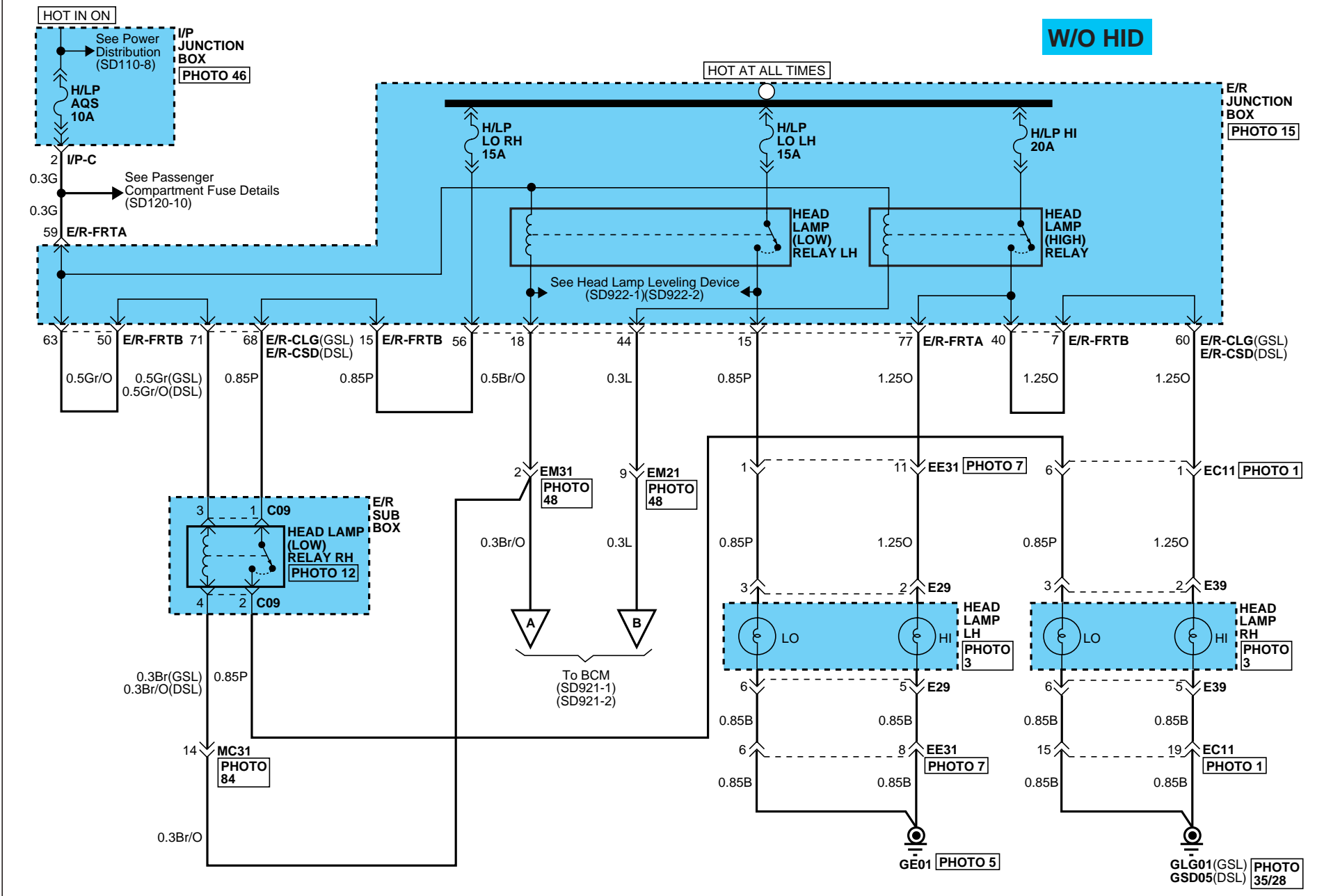

# HEAD LAMPS

## Head Lamps (5)

SD921-5

**C09**

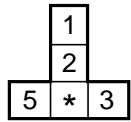

CR05F011

**E29**

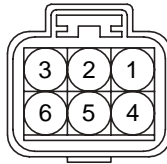

KUM\_NMWP\_06F\_B

**E30**

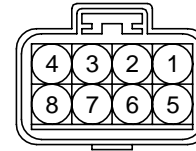

KUM\_NMWP\_08F\_B

**E39**

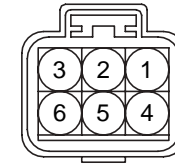

KUM\_NMWP\_06B\_B

**E40**

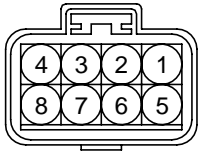

KUM\_NMWP\_08F\_B

**M01-C**

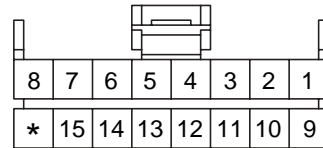

AMP\_040M1\_16F\_B

**M02-L**

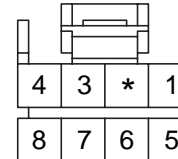

AMP\_040M1\_08F\_B

**M04-A**

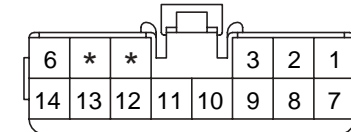

KET\_090II\_14F\_W

**M04-B**

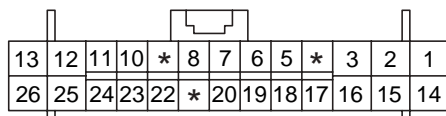

AMP\_0407\_26F\_Gr\_HD

**M04-C**

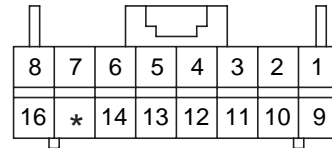

AMP\_0407\_16F\_W\_040

**M04-D**

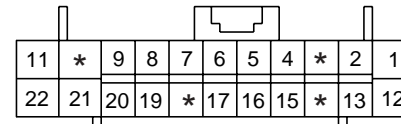

AMP\_0407\_22F\_W\_HD

**M58**

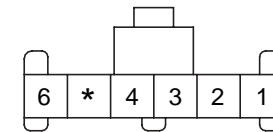

KET\_91A\_06F\_W

**HEAD LAMPS**

Head Lamps (6)

SD921-6

MEMO







# HEAD LAMP LEVELING DEVICE

## Head Lamp Leveling Device (3)

SD922-3

**E23**

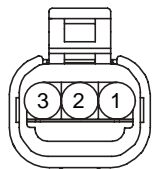

AMP\_025WP\_03F\_B

**E33**

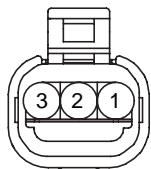

AMP\_025WP\_03F\_B

**F08**

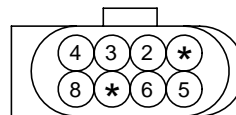

FEP\_8650\_6FEP\_08F\_B

**M41**

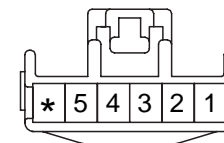

KET\_090II\_06F\_R\_SW

**HEAD LAMP LEVELING DEVICE**

Head Lamp Leveling Device (4)

**SD922-4**

**MEMO**

Head Lamp Washer (1)

SD923-1

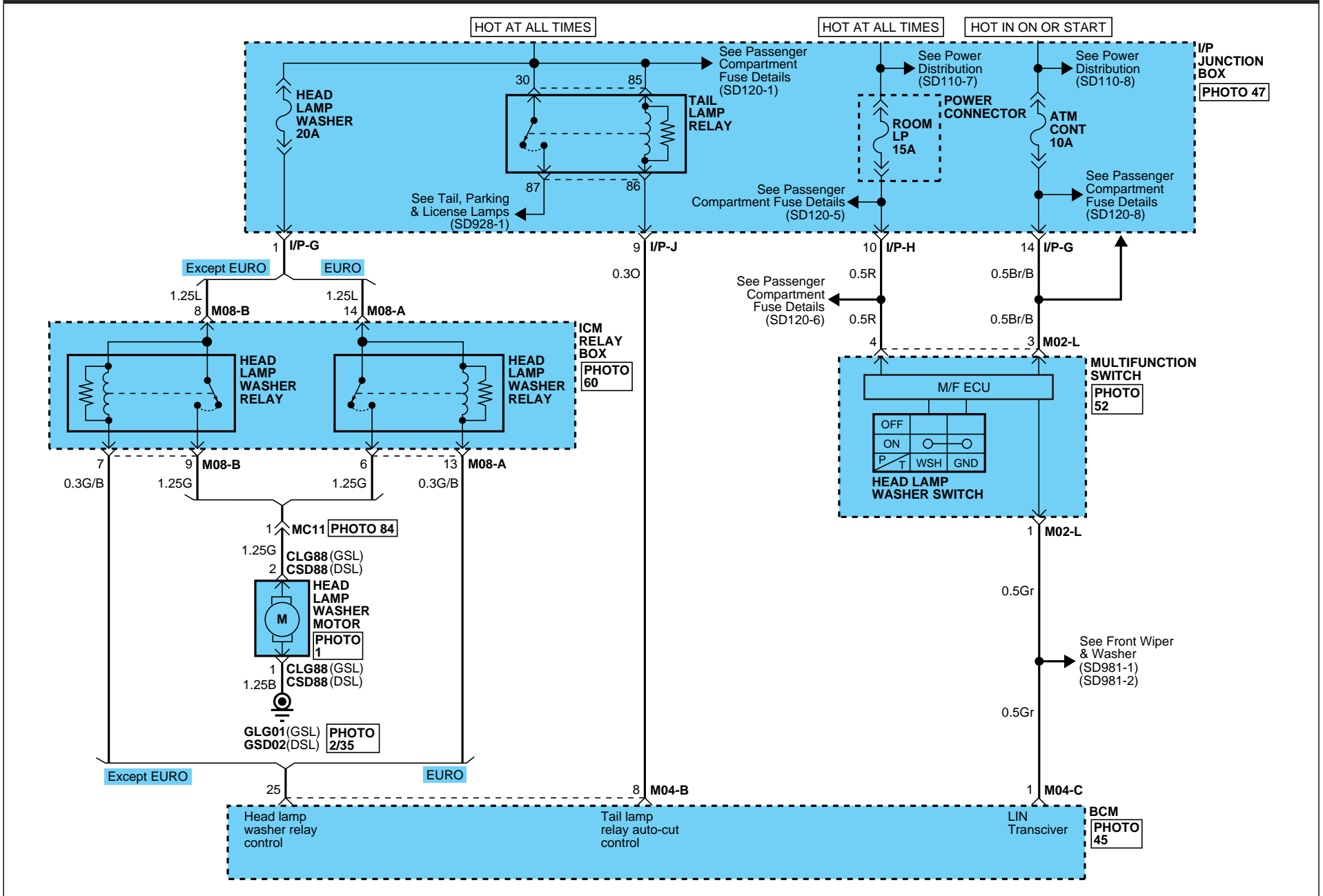

# HEAD LAMP WASHER

## Head Lamp Washer (2)

SD923-2

**CLG88**

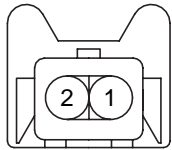

AMP\_JPT\_02F\_B\_ASSY

**CSD88**

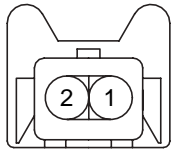

AMP\_JPT\_02F\_B\_ASSY

**M02-L**

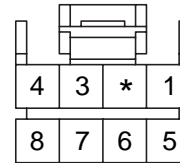

AMP\_040M1\_08F\_B

**M04-B**

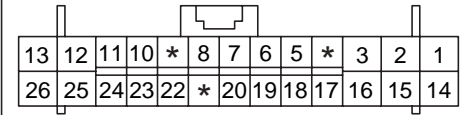

AMP\_0407\_26F\_Gr\_HD

**M04-C**

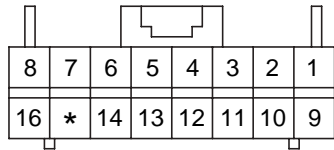

AMP\_0407\_16F\_W\_040

**M08-A**

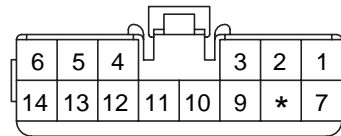

KET\_090II\_14F\_W

**M08-B**

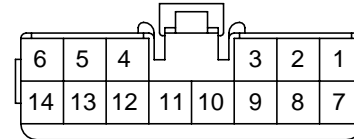

KET\_090II\_14F\_B

**BLANK**

# FRONT FOG & REAR FOG LAMPS

ED388DBF

## Front Fog & Rear Fog Lamps (1)

SD924-1

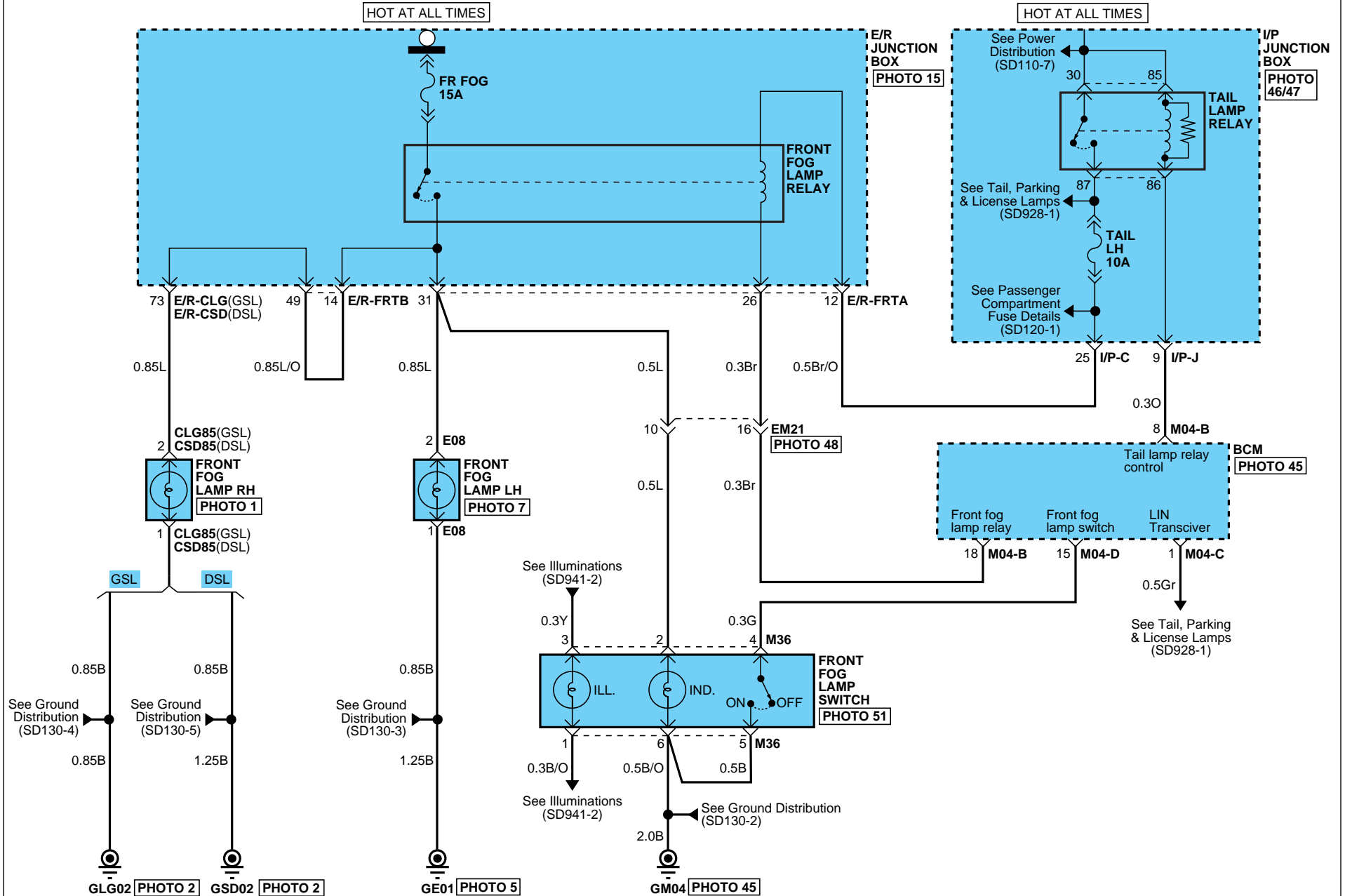



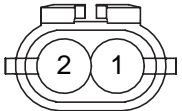
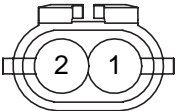
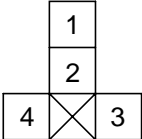
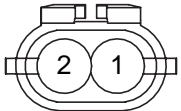
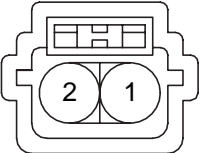
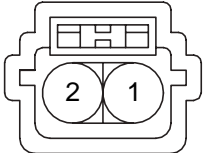
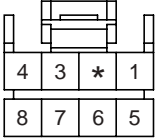
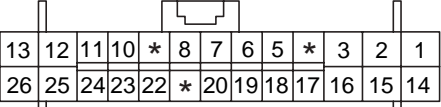
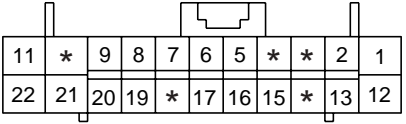
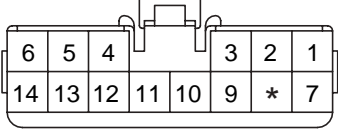
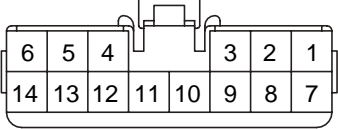
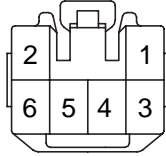
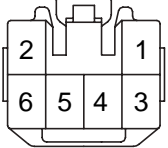

# FRONT FOG & REAR FOG LAMPS

Front Fog & Rear Fog Lamps (3)			SD924-3
<p><b>CLG85</b></p>  <p>PKD_280WP_02F_Gr</p>	<p><b>CSD85</b></p>  <p>PKD_280WP_02F_Gr</p>	<p><b>C09</b></p>  <p>CR04F094</p>	<p><b>E08</b></p>  <p>PKD_280WP_02F_Gr</p>
<p><b>F64</b></p>  <p>KUM_NDWP_02F_Gr</p>	<p><b>F65</b></p>  <p>KUM_NDWP_02F_Gr</p>	<p><b>M02-L</b></p>  <p>AMP_040M1_08F_B</p>	<p><b>M04-B</b></p>  <p>AMP_0407_26F_Gr_HD</p>
<p><b>M04-D</b></p>  <p>AMP_0407_22F_W_HD</p>	<p><b>M08-A</b></p>  <p>KET_090II_14F_W</p>	<p><b>M08-B</b></p>  <p>KET_090II_14F_B</p>	<p><b>M36</b></p>  <p>KET_090II_06F_Y</p>
<p><b>M56</b></p>  <p>KET_090II_06F_Br</p>	<p><b>BLANK</b></p>	<p><b>BLANK</b></p>	<p><b>BLANK</b></p>

**FRONT FOG & REAR FOG LAMPS**

**Front Fog & Rear Fog Lamps (4)**

**SD924-4**

**MEMO**

Turn & Hazard Lamps (1)

SD925-1

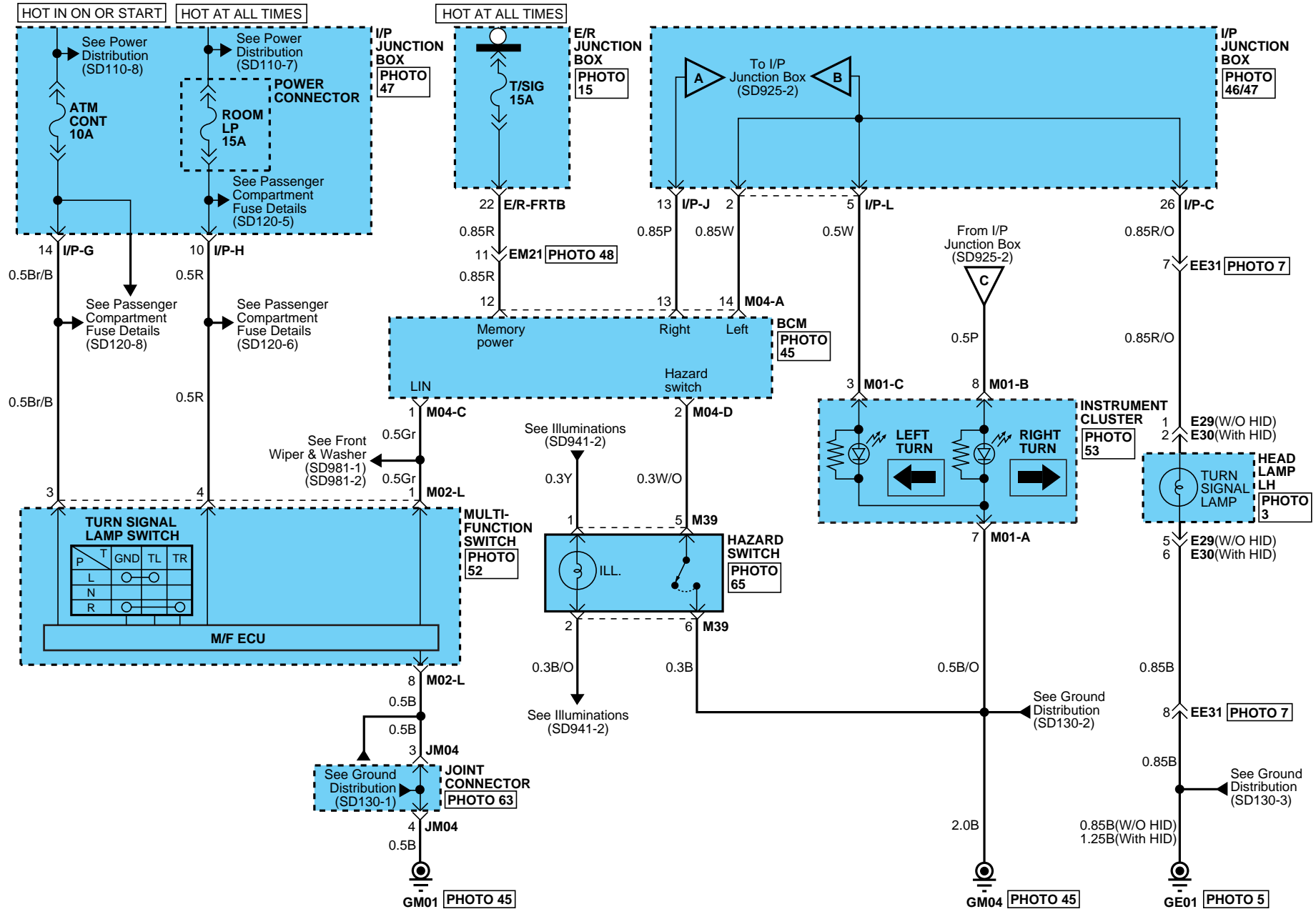

# TURN & HAZARD LAMPS

## Turn & Hazard Lamps (2)

SD925-2

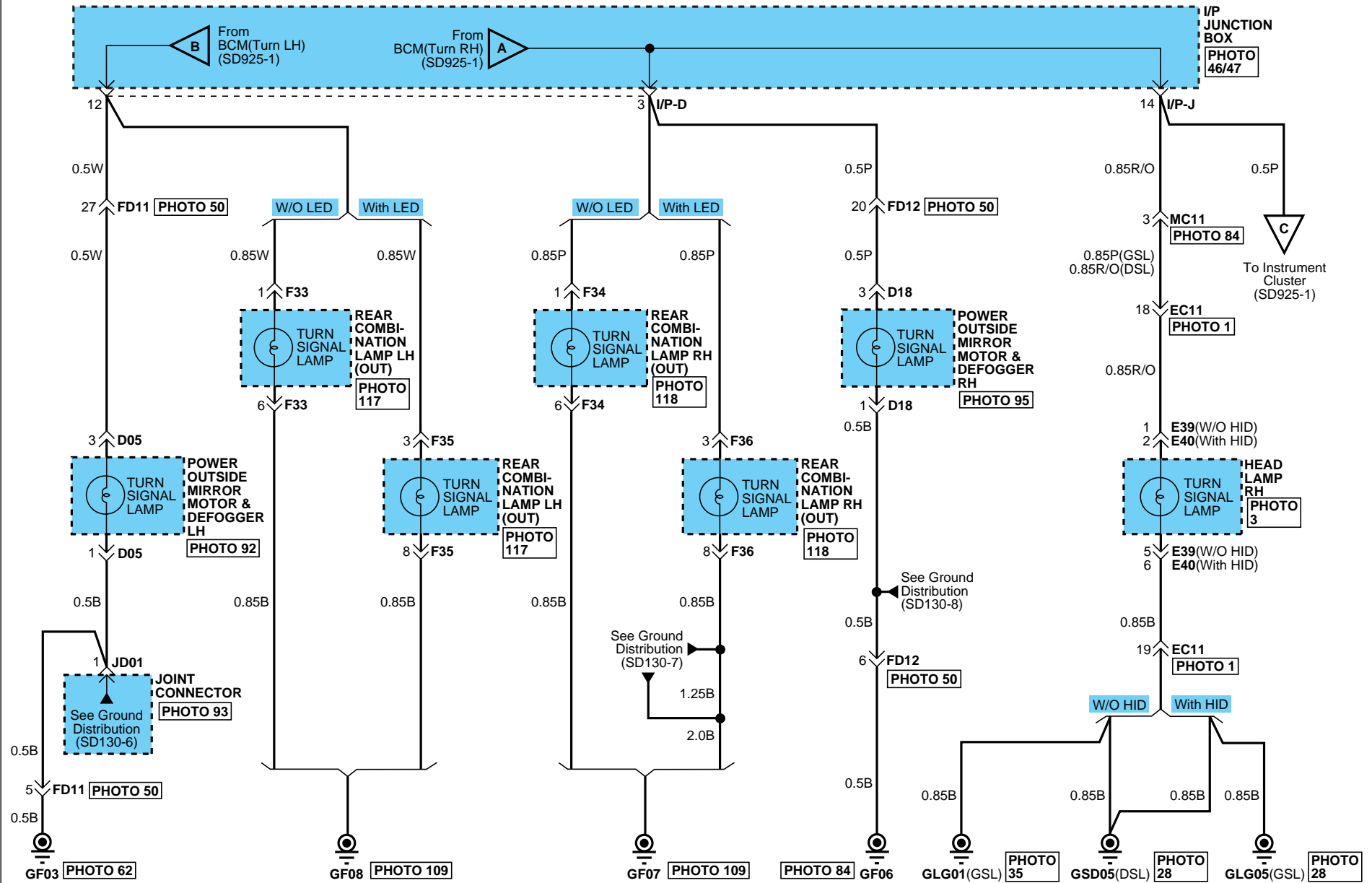

# TURN & HAZARD LAMPS

## Turn & Hazard Lamps (3)

SD925-3

**D05**

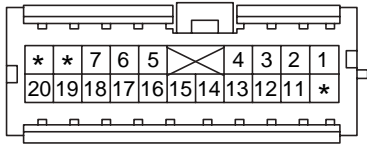

AMP\_040III\_20F\_W

**D18**

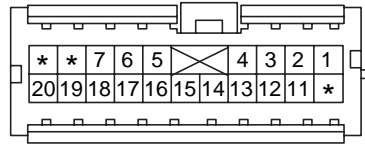

AMP\_040III\_20F\_W

**E29**

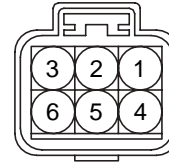

KUM\_NMWP\_06F\_B

**E30**

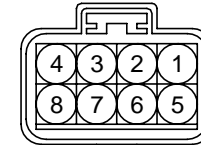

KUM\_NMWP\_08F\_B

**E39**

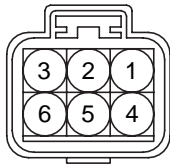

KUM\_NMWP\_06B\_B

**E40**

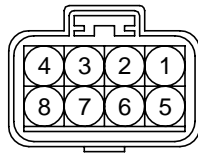

KUM\_NMWP\_08F\_B

**F33**

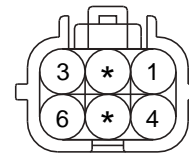

KET\_SWP\_06F\_B

**F34**

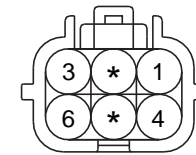

KET\_SWP\_06F\_B

**F35**

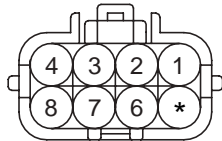

KET\_SWP\_08F\_B

**F36**

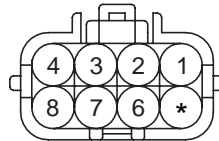

KET\_SWP\_08F\_B

**M01-A**

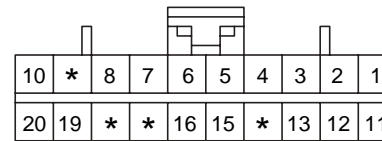

AMP\_040M2\_20F\_B

**M01-B**

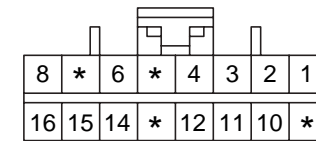

AMP\_040M2\_16F\_B

**M01-C**

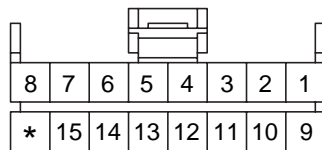

AMP\_040M1\_16F\_B

**M02-L**

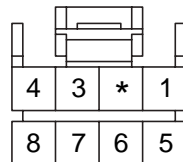

AMP\_040M1\_08F\_B

**M04-A**

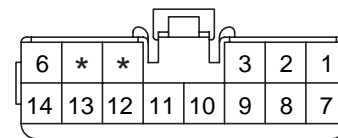

KET\_090II\_14F\_W

**M04-C**

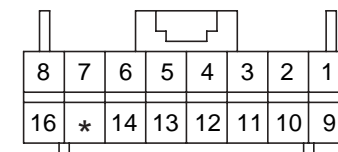

AMP\_0407\_16F\_W\_040

**M04-D**

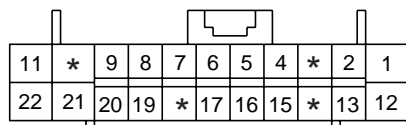

AMP\_0407\_22F\_W\_HD

**M39**

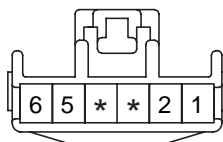

KET\_090II\_06F\_B\_SW

**BLANK**

**BLANK**

**TURN & HAZARD LAMPS**

Turn & Hazard Lamps (4)

SD925-4

MEMO



# BACK-UP LAMPS

## Back-up Lamps (2)

SD926-2

**CLG09**

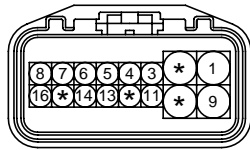

YAZ\_TCMWP\_16F\_B

**CSD09**

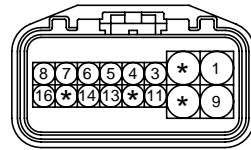

YAZ\_TCMWP\_16F\_B

**F10**

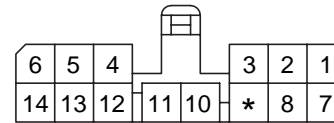

KET\_070\_14F\_W

**F88**

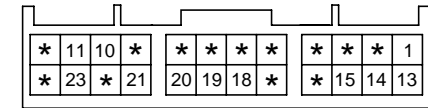

AMP\_040II\_24F\_B

**M07-B**

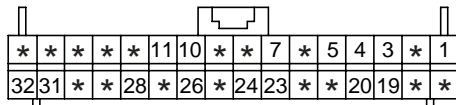

AMP\_025\_32F\_W

**R05**

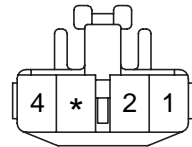

KET\_090II\_04F\_W

**R06**

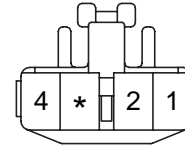

KET\_090II\_04F\_W

**R07**

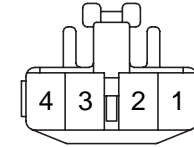

KET\_090II\_04F\_W

**R08**

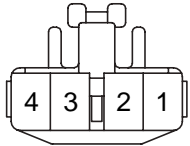

KET\_090II\_04F\_W

**R22**

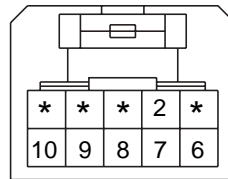

SUM\_025\_10F\_B

**S38-C**

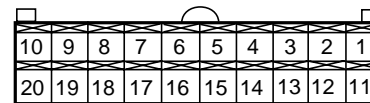

CR20F021

**BLANK**



Stop Lamps (1)

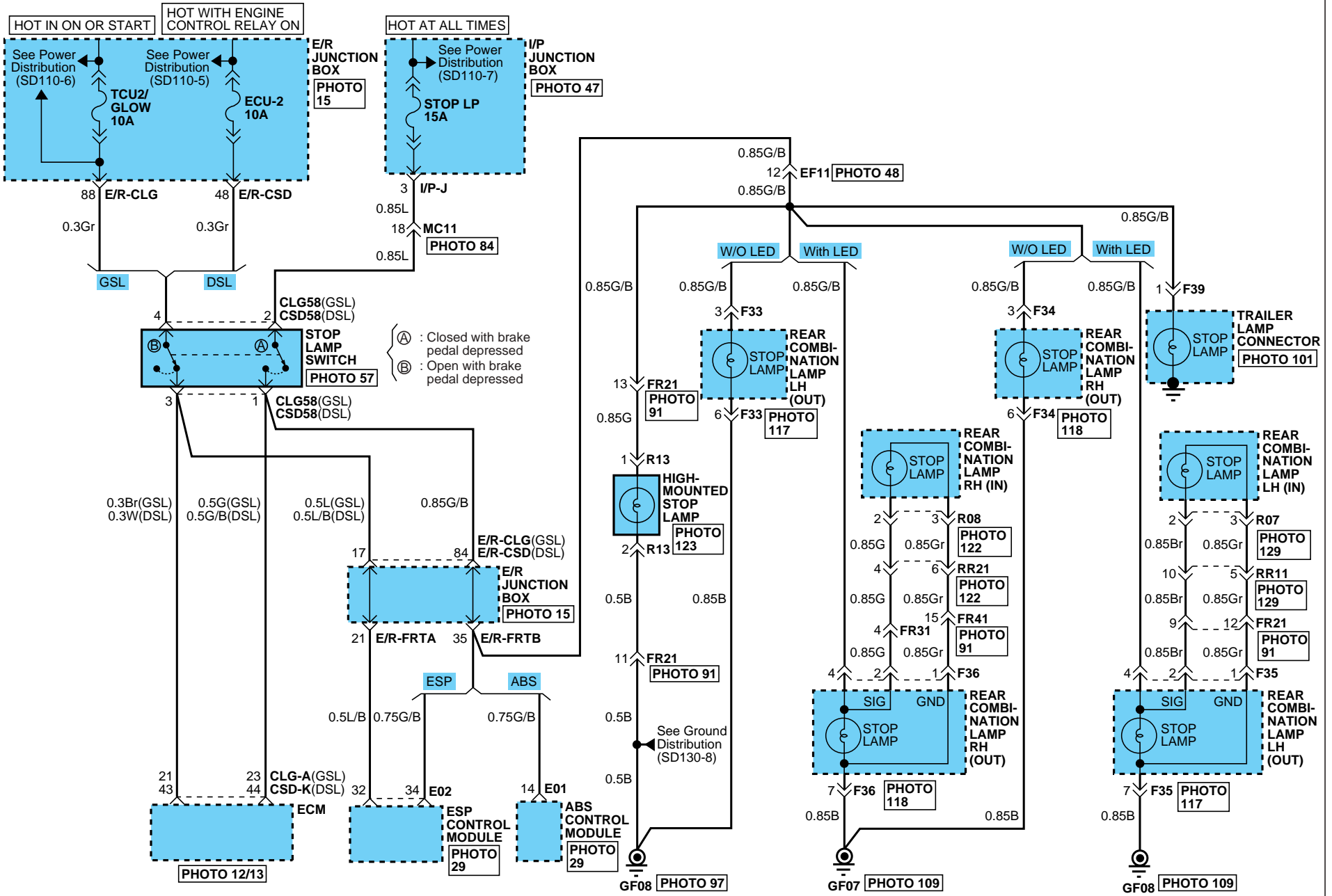

# STOP LAMPS

## Stop Lamps (2)

SD927-2

**CLG-A**

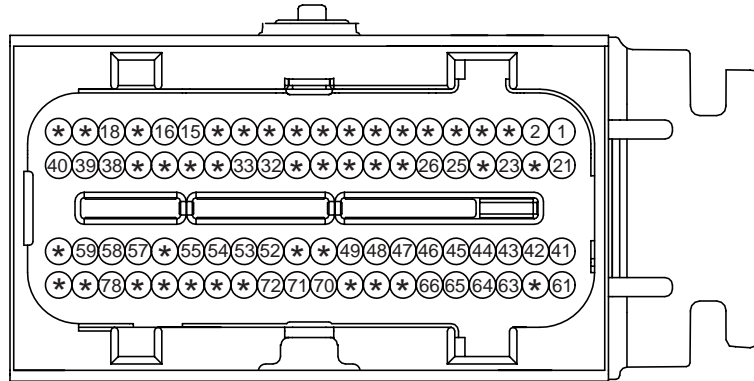

PKD\_ECU\_80F\_GR\_3

**CSD-K**

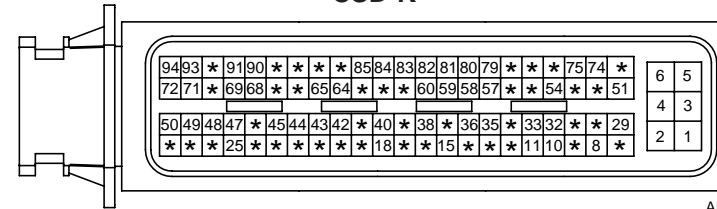

AMP\_ECU\_94F\_B

**CLG58**

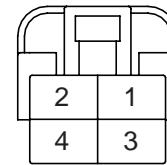

KET\_250DL\_04F\_W

**CSD58**

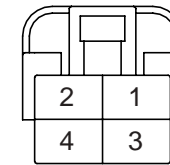

KET\_250DL\_04F\_W

**E01**

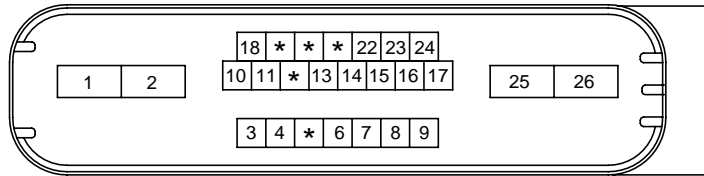

FCI\_ABS\_26F\_B

**E02**

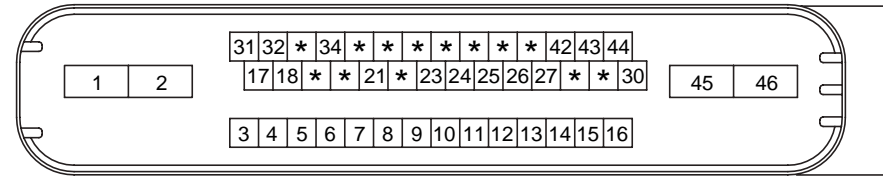

FCI\_ESP\_46F\_B

**F33**

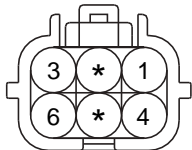

KET\_SWP\_06F\_B

**F34**

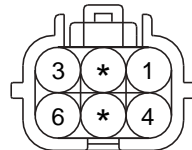

KET\_SWP\_06F\_B

**F35**

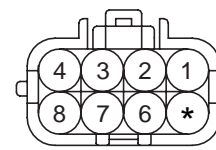

KET\_SWP\_08F\_B

**F36**

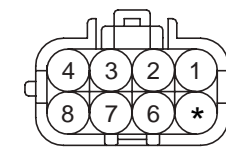

KET\_SWP\_08F\_B

**F39**



KET\_090IWP\_04M\_B

**R07**

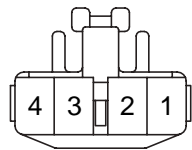

KET\_090II\_04F\_W

**R08**

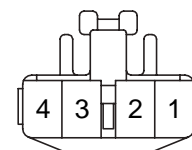

KET\_090II\_04F\_W

**R13**

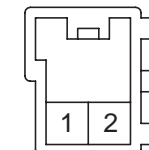

KUM\_CDR\_02M\_W

Tail, Parking & License Lamps (1)

SD928-1

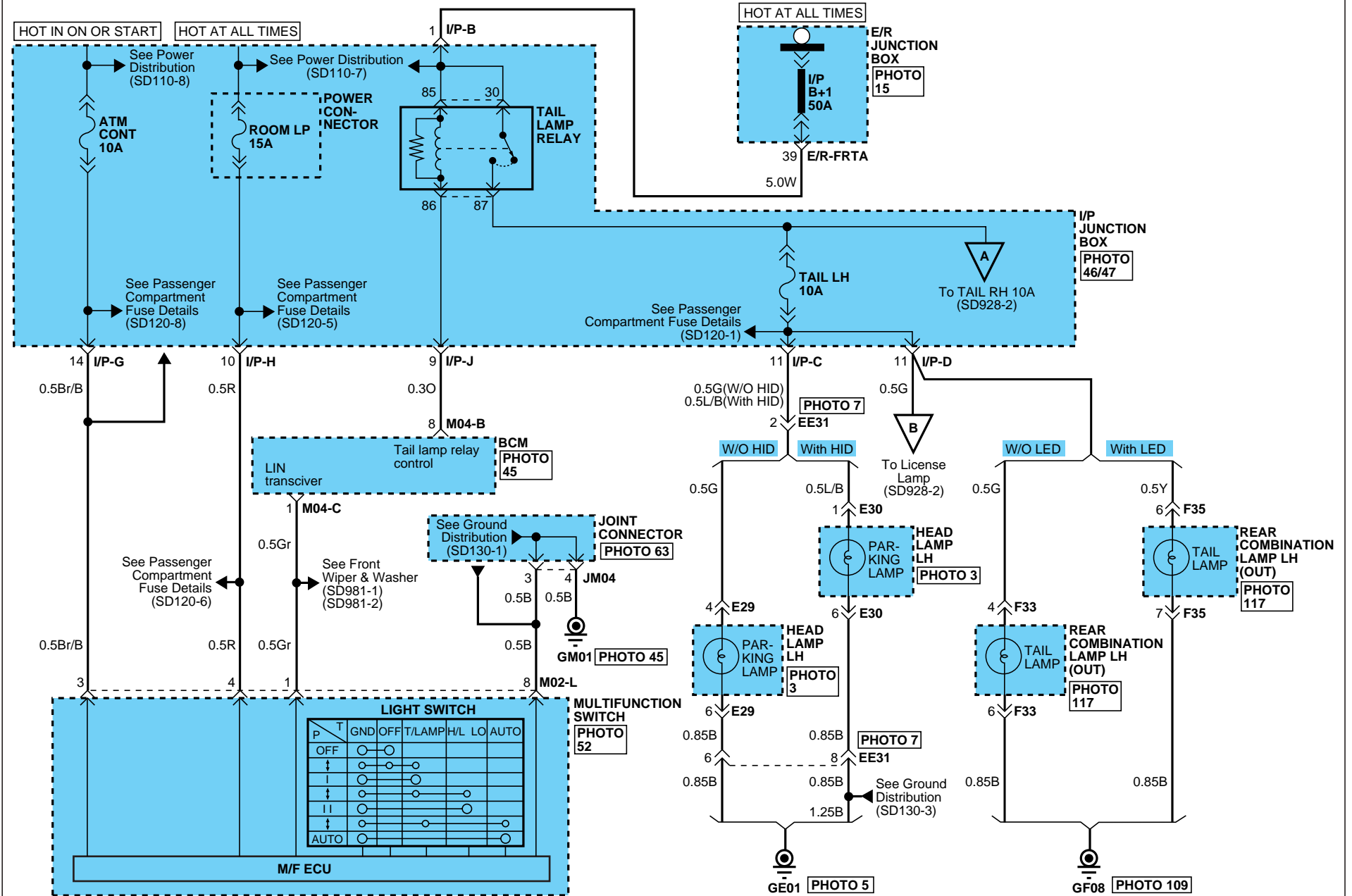

# TAIL, PARKING & LICENSE LAMPS

## Tail, Parking & License Lamps (2)

SD928-2

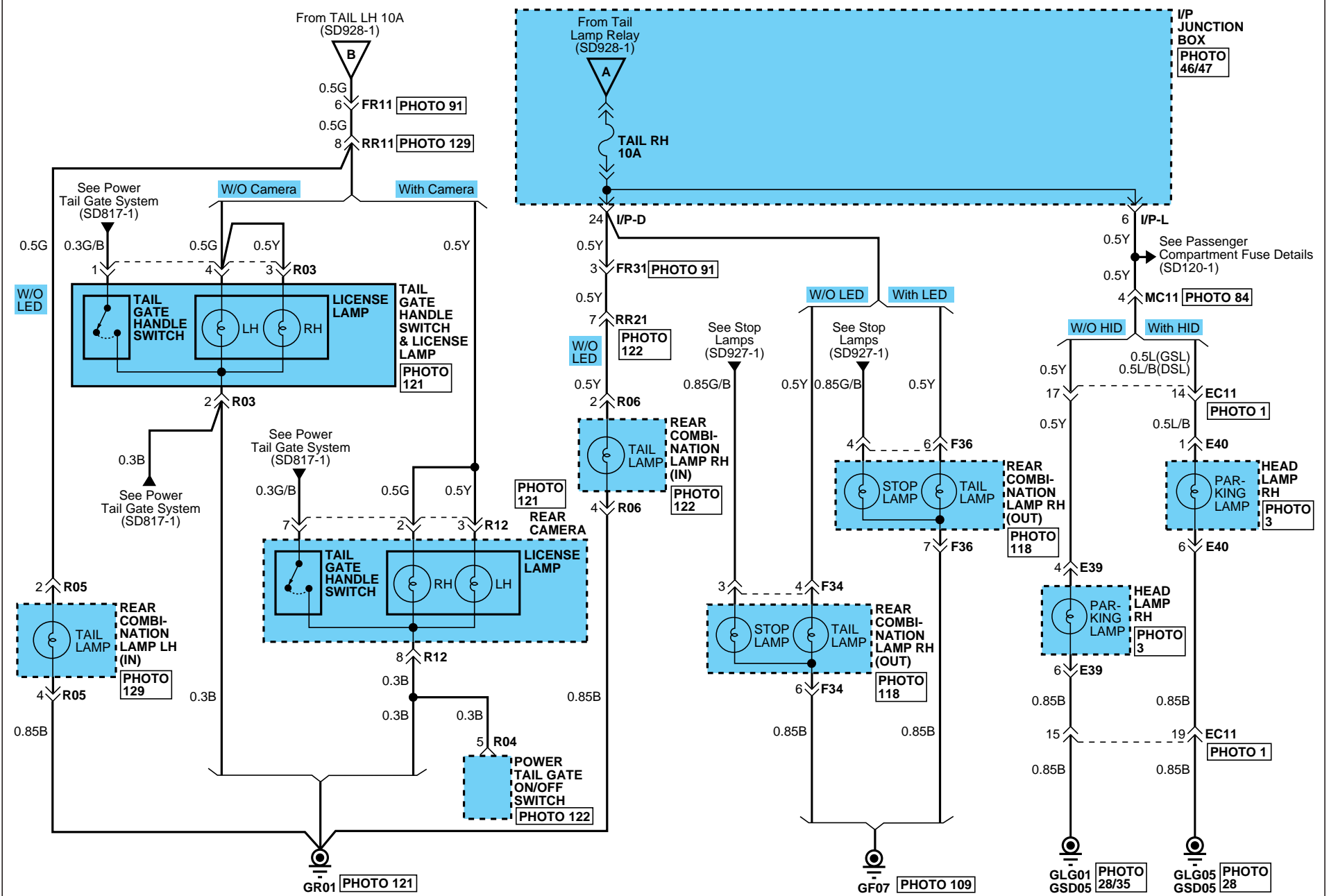

# TAIL, PARKING & LICENSE LAMPS

## Tail, Parking & License Lamps (3)

SD928-3

**E29**



KUM\_NMWP\_06F\_B

**E30**

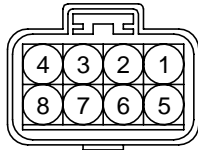

KUM\_NMWP\_08F\_B

**E39**

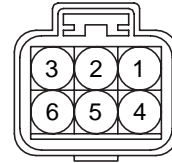

KUM\_NMWP\_06F\_B

**E40**

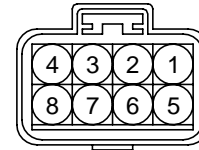

KUM\_NMWP\_08F\_B

**F33**

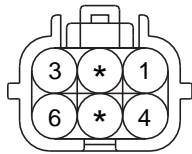

KET\_SWP\_06F\_B

**F34**

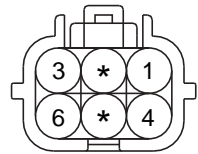

KET\_SWP\_06F\_B

**F35**

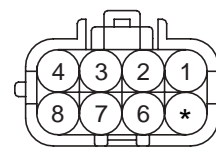

KET\_SWP\_08F\_B

**F36**

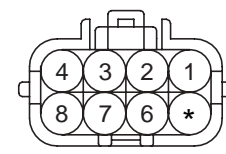

KET\_SWP\_08F\_B

**F39**



KET\_090IWP\_04M\_B

**M02-L**

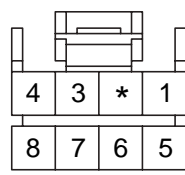

AMP\_040M1\_08F\_B

**M04-B**

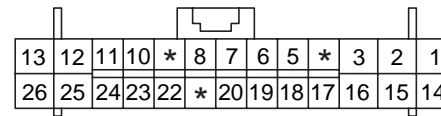

AMP\_0407\_26F\_Gr\_HD

**M04-C**

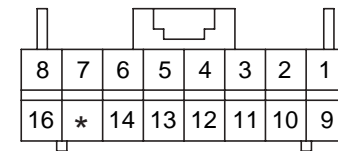

AMP\_0407\_16F\_W\_040

**R03**

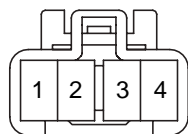

KET\_090II\_04M\_W

**R05**

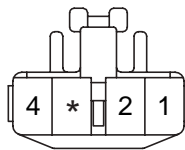

KET\_090II\_04F\_W

**R06**

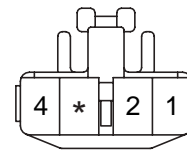

KET\_090II\_04F\_W

**R12**

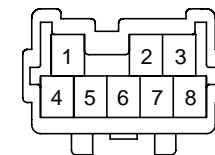

KET\_070\_8M\_W

**R04**

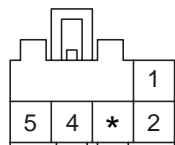

KUM\_CDR\_05F\_W

**TAIL, PARKING & LICENSE LAMPS**

**Tail, Parking & License Lamps (4)**

**SD928-4**

**MEMO**

Courtesy & Tail Gate Room Lamps (1)

SD929-1

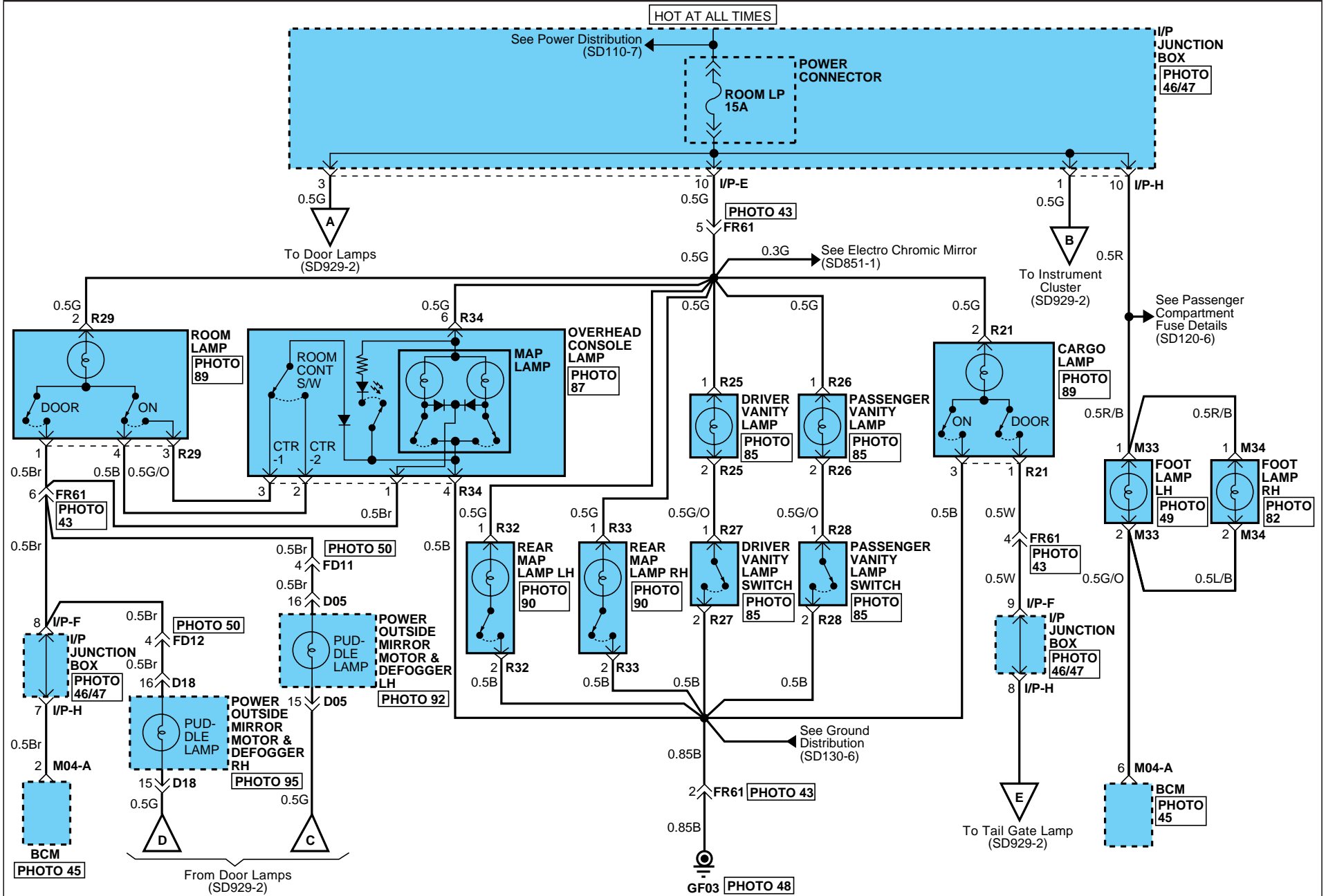





WITH DOOR SCUFF LAMP

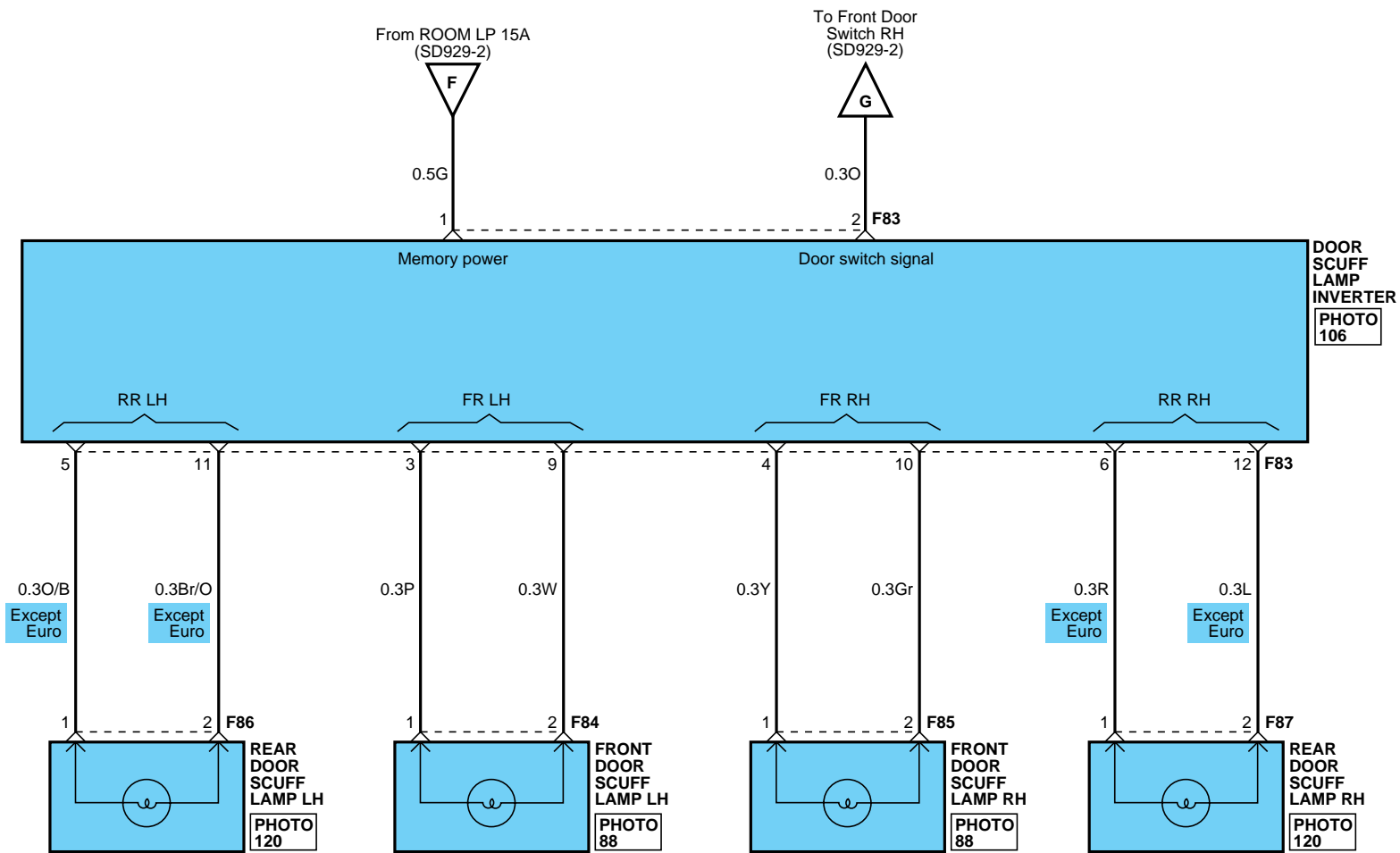

# COURTESY & TAIL GATE ROOM LAMPS

## Courtesy & Tail Gate Room Lamps (4)

SD929-4

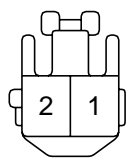
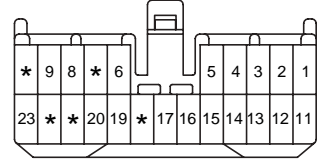
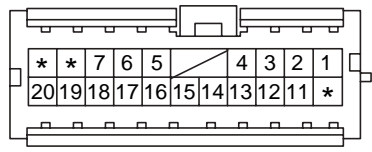
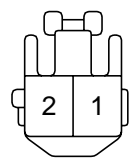
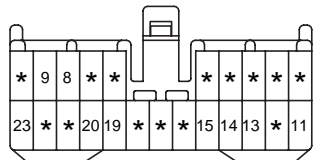
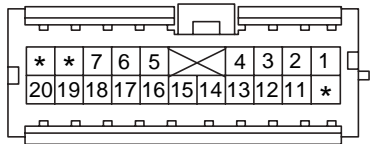
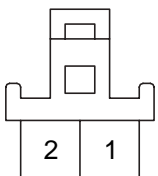
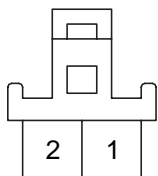
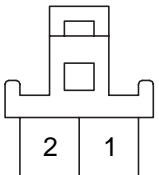
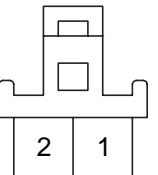
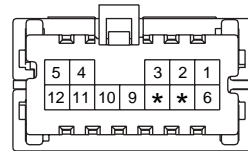
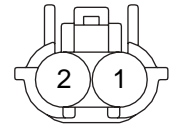
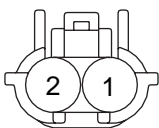
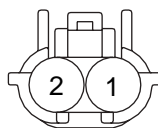
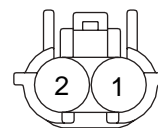
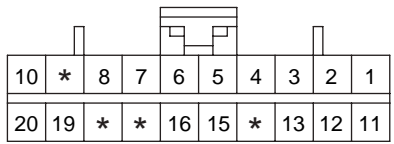
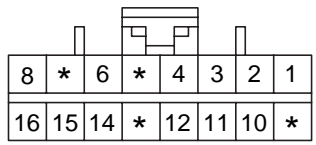
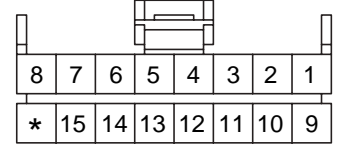
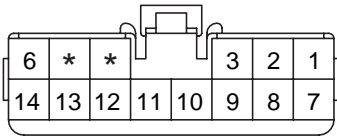
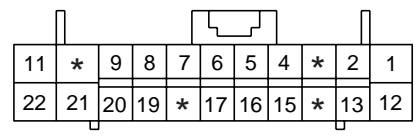
<p><b>D01</b></p>  <p>KET_090III_02F_W_L</p>	<p><b>D03-B</b></p>  <p>KET_050_23F_W</p>	<p><b>D05</b></p>  <p>AMP_040III_20F_W</p>	<p><b>D13</b></p>  <p>KET_090III_02F_W_L</p>
<p><b>D14-B</b></p>  <p>KET_050_23F_W</p>	<p><b>D18</b></p>  <p>AMP_040III_20F_W</p>	<p><b>F13</b></p>  <p>KET_070_02F_W</p>	<p><b>F14</b></p>  <p>KET_070_02F_W</p>
<p><b>F15</b></p>  <p>KET_070_02F_W</p>	<p><b>F16</b></p>  <p>KET_070_02F_W</p>	<p><b>F83</b></p>  <p>KET_040III_12F_W</p>	<p><b>F84</b></p>  <p>KET_SWP_02F_B</p>
<p><b>F85</b></p>  <p>KET_SWP_02F_B</p>	<p><b>F86</b></p>  <p>KET_SWP_02F_B</p>	<p><b>F87</b></p>  <p>KET_SWP_02F_B</p>	<p><b>M01-A</b></p>  <p>AMP_040M2_20F_B</p>
<p><b>M01-B</b></p>  <p>AMP_040M2_16F_B</p>	<p><b>M01-C</b></p>  <p>AMP_040M1_16F_B</p>	<p><b>M04-A</b></p>  <p>KET_090II_14F_W</p>	<p><b>M04-D</b></p>  <p>AMP_0407_22F_W_HD</p>

**COURTESY & TAIL GATE ROOM LAMPS**

**Courtesy & Tail Gate Room Lamps (5)**

**SD929-5**

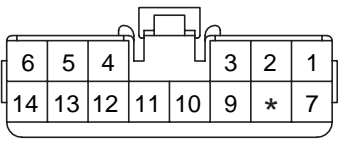
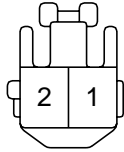
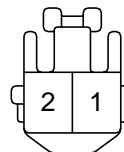
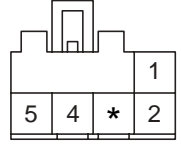
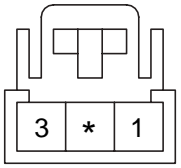
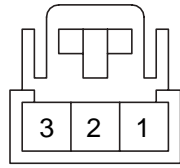
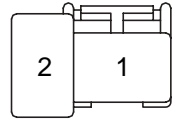
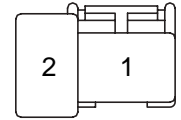
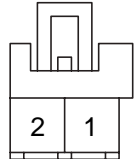
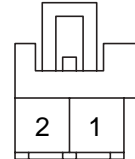
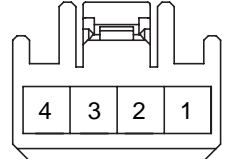
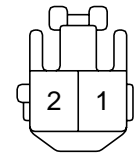
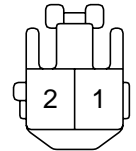
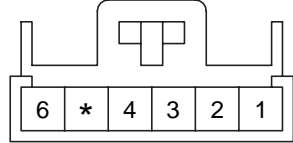
<p><b>M08-A</b></p>  <p>KET_090II_14F_W</p>	<p><b>M33</b></p>  <p>KET_090II_02F_W_L</p>	<p><b>M34</b></p>  <p>KET_090II_02F_W_L</p>	<p><b>R04</b></p>  <p>KUM_CDR_05F_W</p>
<p><b>R11</b></p>  <p>AMP_070_03F_W</p>	<p><b>R21</b></p>  <p>AMP_070_03F_W</p>	<p><b>R25</b></p>  <p>AMP_PLM2_02F_B</p>	<p><b>R26</b></p>  <p>AMP_PLM2_02F_B</p>
<p><b>R27</b></p>  <p>KUM_CDR_02F_W</p>	<p><b>R28</b></p>  <p>KUM_CDR_02F_W</p>	<p><b>R29</b></p>  <p>AMP_090III_04F_W</p>	<p><b>R32</b></p>  <p>KET_090II_02F_W_L</p>
<p><b>R33</b></p>  <p>KET_090II_02F_W_L</p>	<p><b>R34</b></p>  <p>AMP_070_06F_W</p>	<p><b>BLANK</b></p>	<p><b>BLANK</b></p>
Empty row for additional lamp types			

**COURTESY & TAIL GATE ROOM LAMPS**

**Courtesy & Tail Gate Room Lamps (6)**

**SD929-6**

**MEMO**

# TRAILER LAMPS CONNECTOR

EA97F2AE

## Trailer Lamps Connector (1)

SD930-1

**EURO**

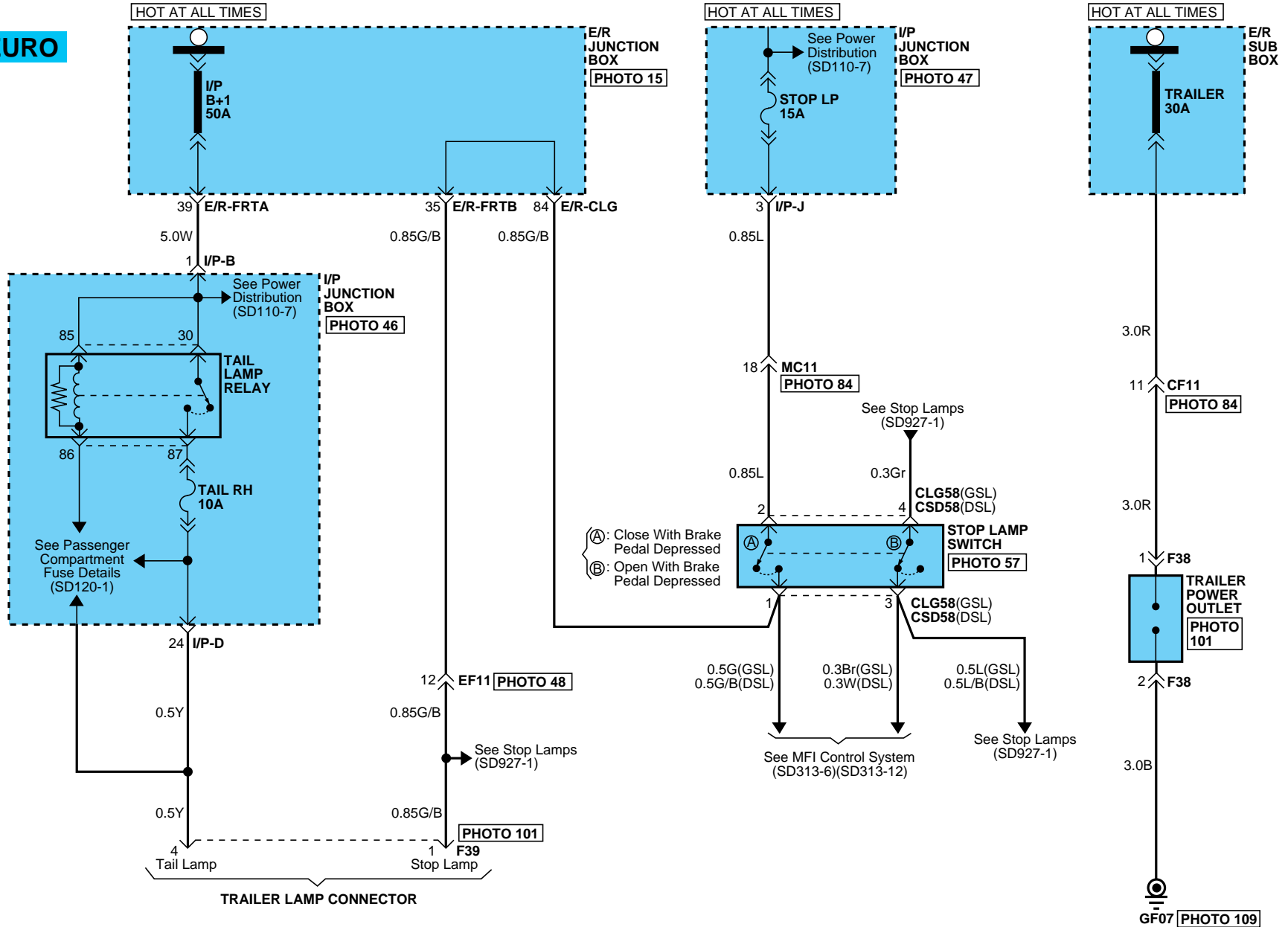

# TRAILER LAMPS CONNECTOR

## Trailer Lamps Connector (2)

SD930-2

**CLG58**

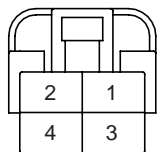

KET\_250DL\_04F\_W

**CSD58**

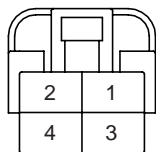

KET\_250DL\_04F\_W

**F39**

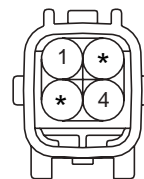

KET\_090IWP\_04M\_B

**F38**

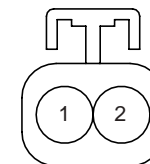

KET\_58X\_02M\_B

Indicators & Gauges (1)

SD940-1

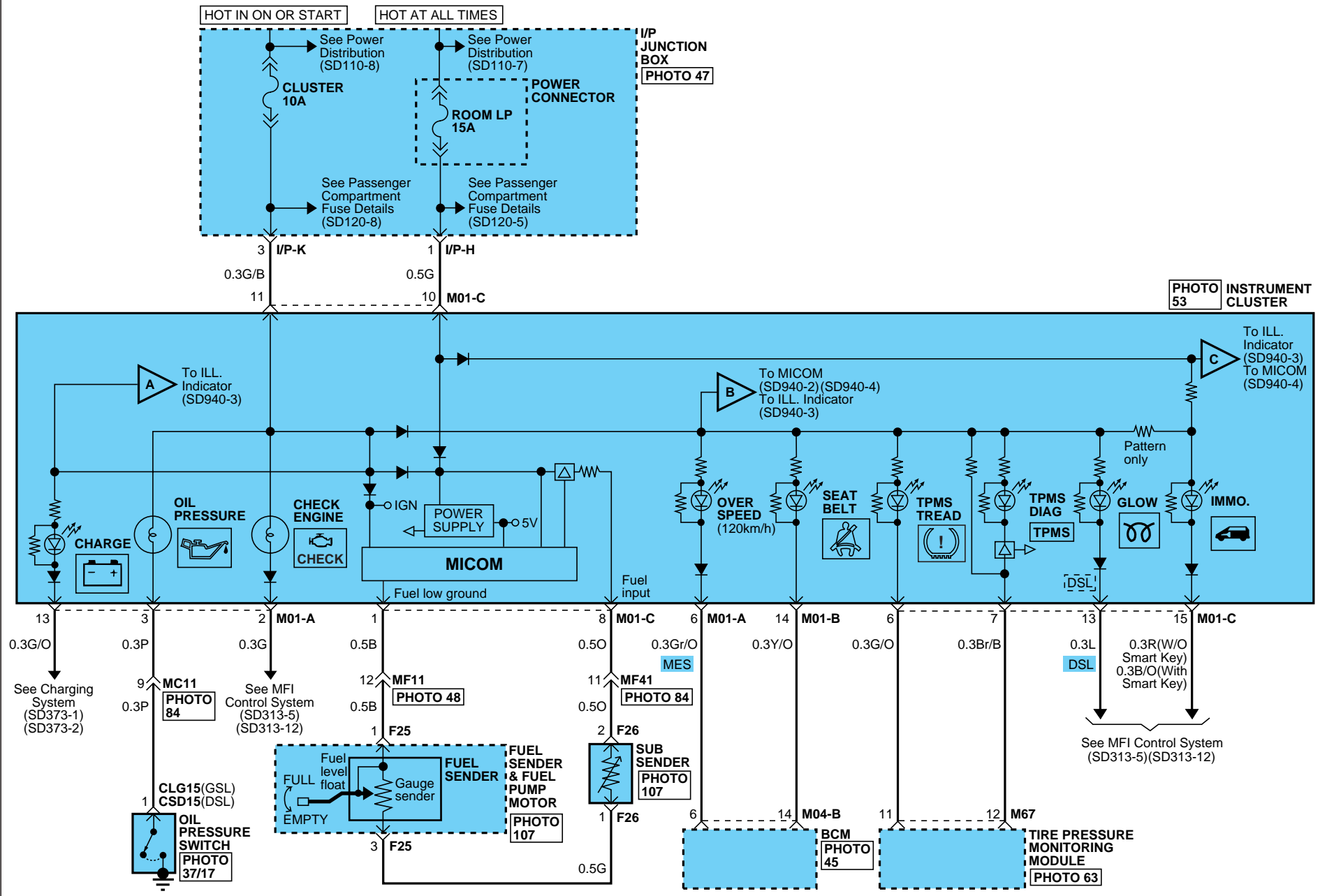

# INDICATORS & GAUGES

## Indicators & Gauges (2)

SD940-2

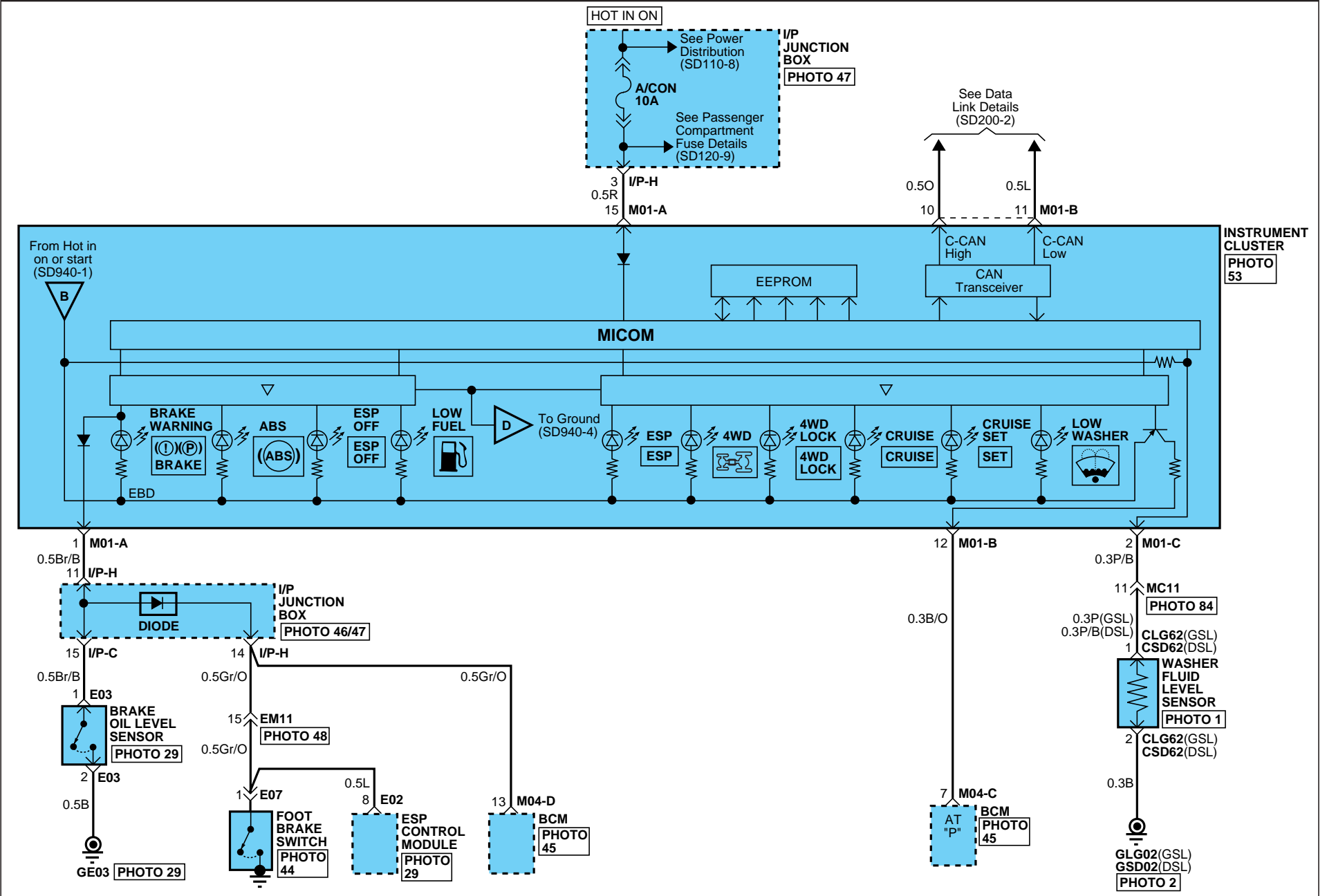



# INDICATORS & GAUGES

## Indicators & Gauges (3)

SD940-3

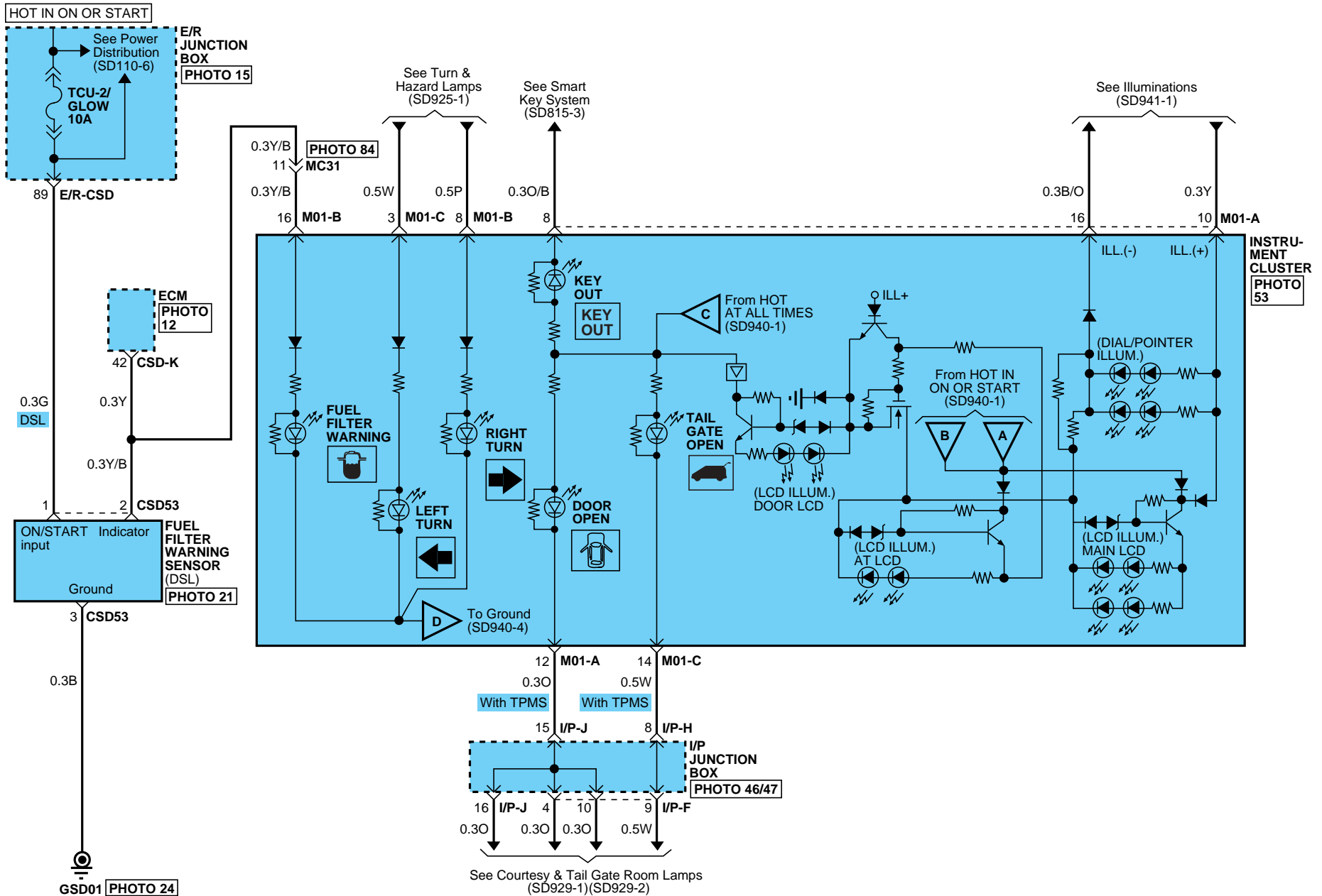

# INDICATORS & GAUGES

## Indicators & Gauges (4)

SD940-4

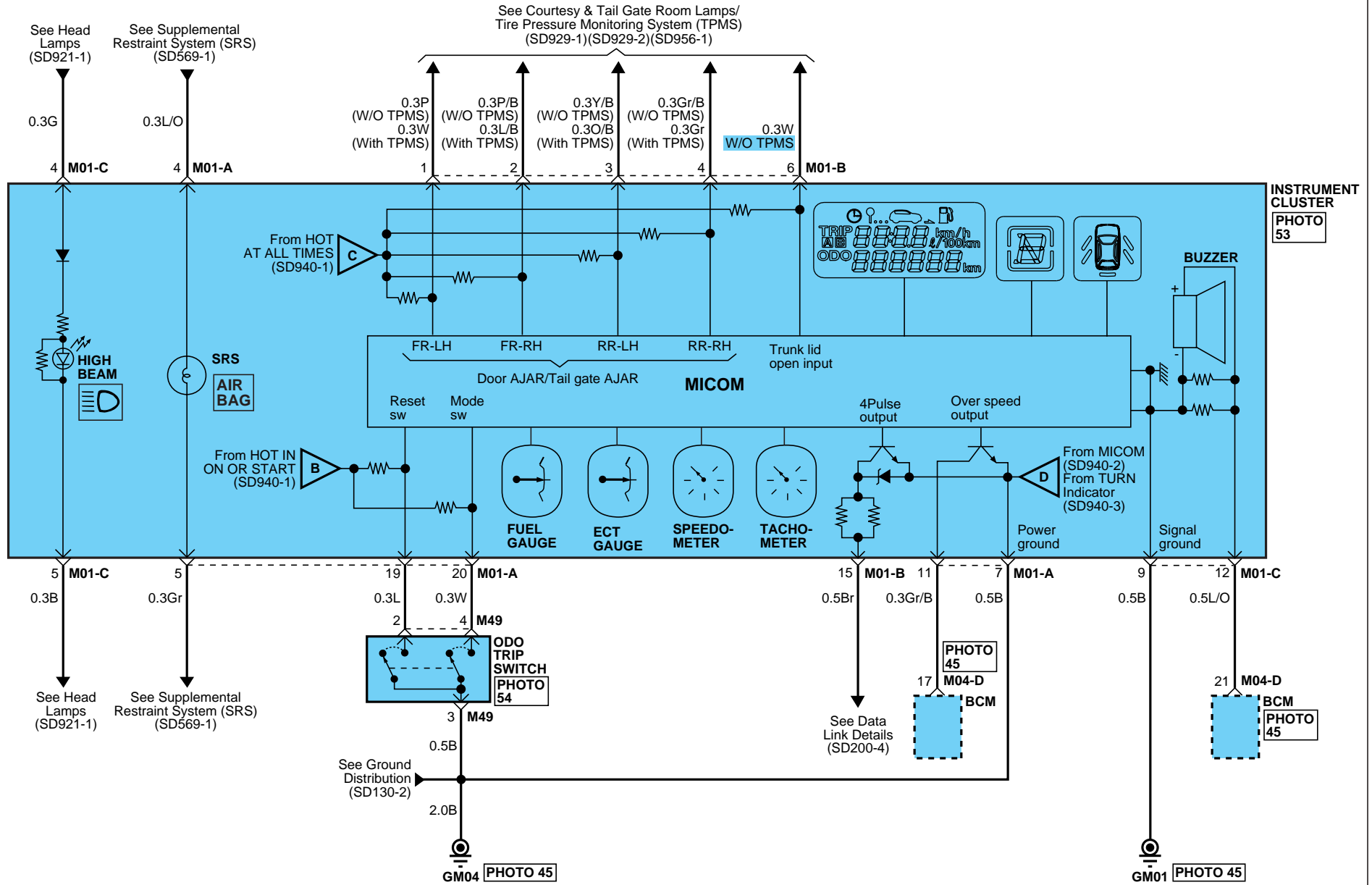

**INDICATORS & GAUGES**

Indicators & Gauges (5)		SD940-5	
<p><b>CSD-K</b></p> <p>AMP_ECU_94F_B</p>		<p><b>CLG15</b></p> <p>KUM_NMWP_01F_B</p>	
<p><b>CSD53</b></p> <p>AMP_1.5WP_03F_B</p>		<p><b>CLG62</b></p> <p>KUM_NMWP_02F_B</p>	
<p><b>CSD15</b></p> <p>KUM_NMWP_01F_B</p>		<p><b>CSD62</b></p> <p>KUM_NMWP_02F_B</p>	
<p><b>E02</b></p> <p>FCI_ESP_46F_B</p>		<p><b>E03</b></p> <p>KET_SSO_02F_B</p>	
<p><b>E07</b></p> <p>KET_250_01M_B</p>		<p><b>M01-A</b></p> <p>AMP_040M2_20F_B</p>	
<p><b>F25</b></p> <p>KET_090IWP_05F_Gr_2</p>		<p><b>M01-B</b></p> <p>AMP_040M2_16F_B</p>	
<p><b>F26</b></p> <p>AMP_090WP_02F_B</p>		<p><b>M01-C</b></p> <p>AMP_040M1_16F_B</p>	
<p><b>M04-B</b></p> <p>AMP_0407_26F_Gr_HD</p>		<p><b>M04-C</b></p> <p>AMP_0407_16F_W_040</p>	
<p><b>M04-D</b></p> <p>AMP_0407_22F_W_HD</p>		<p><b>M04-D</b></p> <p>AMP_0407_22F_W_HD</p>	

# INDICATORS & GAUGES

## Indicators & Gauges (6)

SD940-6

M49

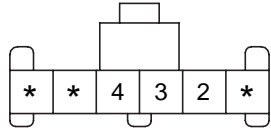

KET\_91A\_06F\_W

M67

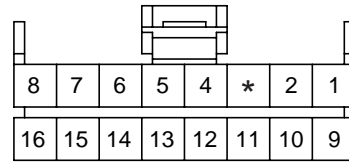

AMP\_040M1\_16F\_B

BLANK

BLANK

Illuminations (1)

SD941-1

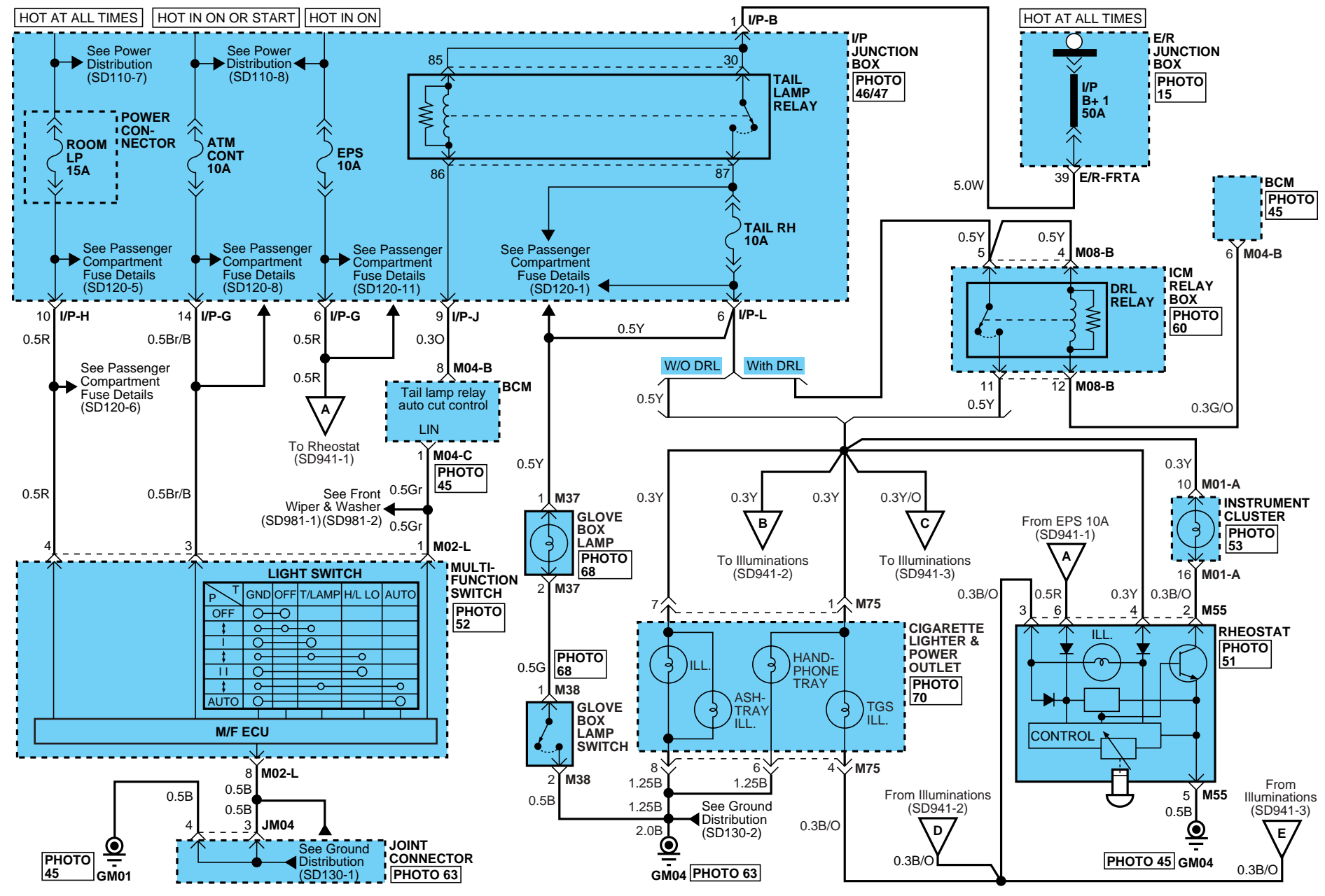



# ILLUMINATIONS

## Illuminations (3)

SD941-3

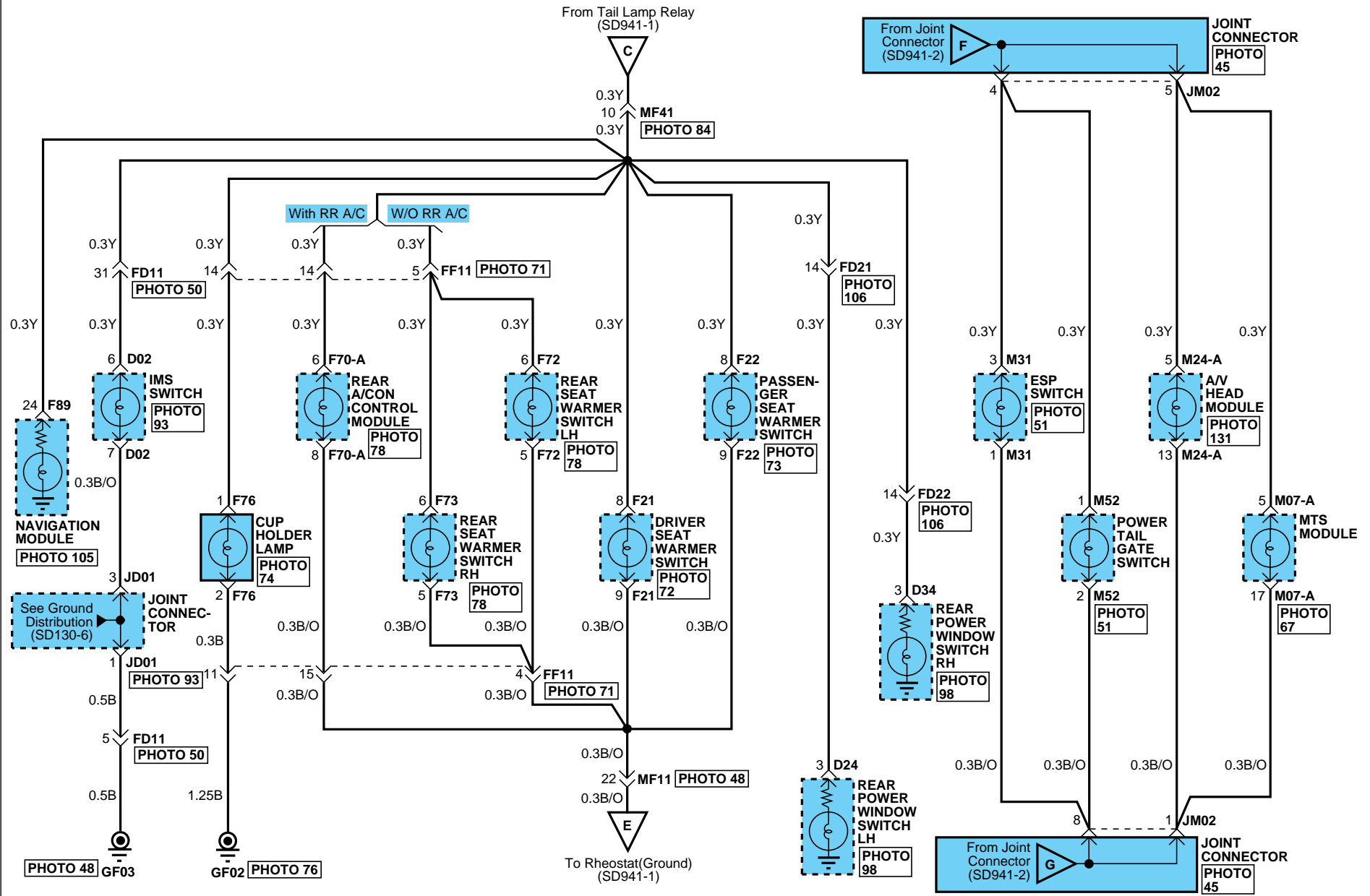

# ILLUMINATIONS

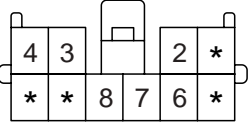
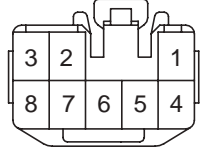
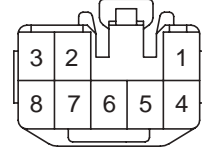
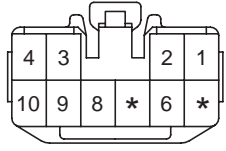
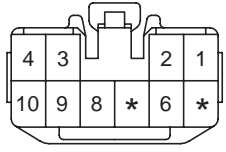
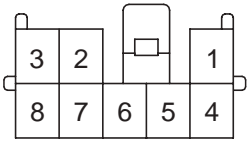
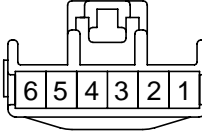
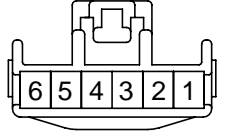
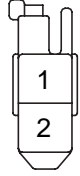
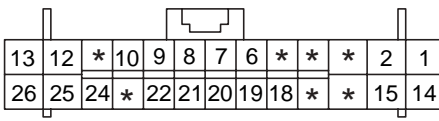
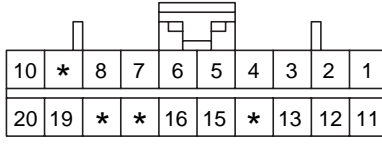
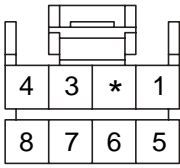
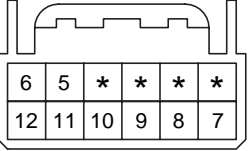
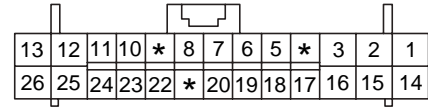
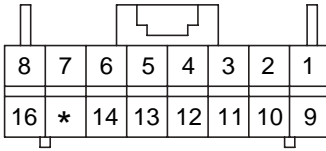
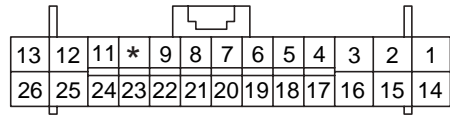
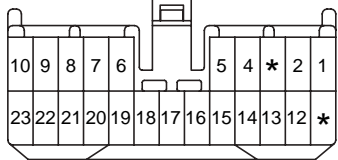
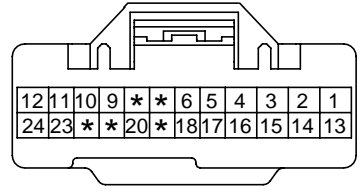
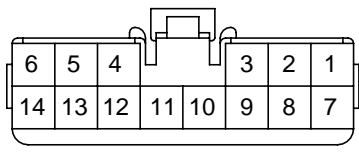
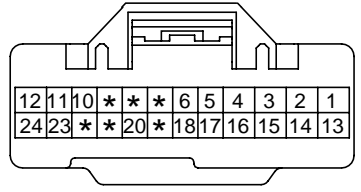

Illuminations (4)				SD941-4
<p><b>D02</b></p>  <p>KET_070_10F_W</p>	<p><b>D24</b></p>  <p>KET_090III_08F_W</p>	<p><b>D34</b></p>  <p>KET_090III_08F_W</p>	<p><b>F21</b></p>  <p>KET_090II_10F_L_SW</p>	
<p><b>F22</b></p>  <p>KET_090II_10F_Y_SW</p>	<p><b>F70-A</b></p>  <p>KET_070_08F_W</p>	<p><b>F72</b></p>  <p>KET_090II_06F_W</p>	<p><b>F73</b></p>  <p>KET_090II_06F_W</p>	
<p><b>F76</b></p>  <p>KET_090II_02F_W</p>	<p><b>F89</b></p>  <p>AMP_0407_26F_W_HD</p>	<p><b>M01-A</b></p>  <p>AMP_040M2_20F_B</p>	<p><b>M02-L</b></p>  <p>AMP_040M1_08F_B</p>	
<p><b>M02-R</b></p>  <p>AMP_025_12F_W</p>	<p><b>M04-B</b></p>  <p>AMP_0407_26F_Gr_HD</p>	<p><b>M04-C</b></p>  <p>AMP_0407_16F_W_040</p>	<p><b>M05-A</b></p>  <p>AMP_0407_26F_W_HD</p>	
<p><b>M06-A</b></p>  <p>KET_050_23F_W</p>	<p><b>M07-A</b></p>  <p>KET_0409_24F_W</p>	<p><b>M08-B</b></p>  <p>KET_090II_14F_B</p>	<p><b>M18</b></p>  <p>KET_0409_24F_W</p>	



# ILLUMINATIONS

## Illuminations (5)

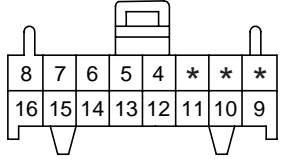
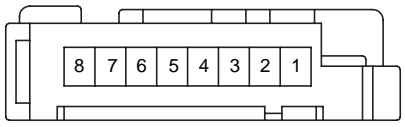
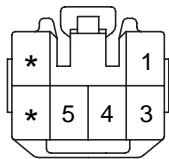
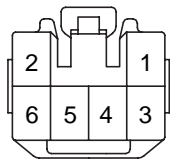
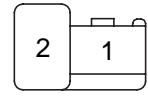
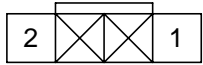
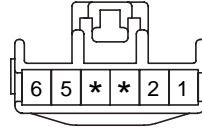
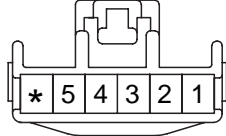
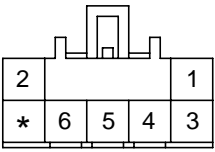
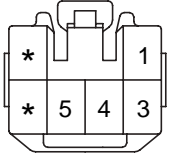
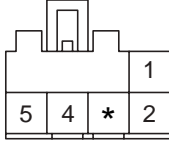
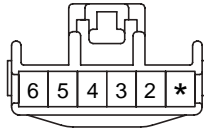
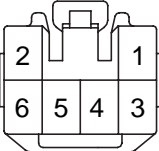
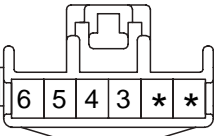
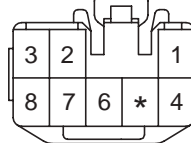
SD941-5

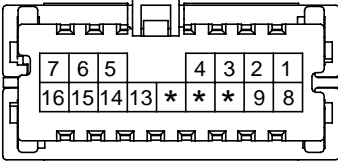
<p style="text-align: center;"><b>M24-A</b></p>  <p style="text-align: center;">AMP_DLI_16F_B</p>	<p style="text-align: center;"><b>M30</b></p>  <p style="text-align: center;">AMP_MQS_08F_W</p>	<p style="text-align: center;"><b>M31</b></p>  <p style="text-align: center;">KET_090II_06F_Gr</p>	<p style="text-align: center;"><b>M36</b></p>  <p style="text-align: center;">KET_090II_06F_Y</p>
<p style="text-align: center;"><b>M37</b></p>  <p style="text-align: center;">AMP_PLM2_02F_B</p>	<p style="text-align: center;"><b>M38</b></p>  <p style="text-align: center;">KET_187_02F_W</p>	<p style="text-align: center;"><b>M39</b></p>  <p style="text-align: center;">KET_090II_06F_B_SW</p>	<p style="text-align: center;"><b>M41</b></p>  <p style="text-align: center;">KET_090II_06F_R_SW</p>
<p style="text-align: center;"><b>M46</b></p>  <p style="text-align: center;">KUM_CDR_07F_W</p>	<p style="text-align: center;"><b>M48</b></p>  <p style="text-align: center;">KET_090II_06F_L_SW</p>	<p style="text-align: center;"><b>M52</b></p>  <p style="text-align: center;">KUM_CDR_05F_W</p>	<p style="text-align: center;"><b>M55</b></p>  <p style="text-align: center;">KET_090II_06F_W_SW</p>
<p style="text-align: center;"><b>M56</b></p>  <p style="text-align: center;">KET_090II_06F_Br</p>	<p style="text-align: center;"><b>M70</b></p>  <p style="text-align: center;">KET_090II_06F_L</p>	<p style="text-align: center;"><b>M75</b></p>  <p style="text-align: center;">KET_090III_08F_W</p>	<p style="text-align: center;"><b>M80-A</b></p>  <p style="text-align: center;">AMP_AUDIO_08F_Gr_D2</p>
<p style="text-align: center;"><b>M83</b></p>  <p style="text-align: center;">KET_040III_16F_R</p>	<p style="text-align: center;"><b>BLANK</b></p>	<p style="text-align: center;"><b>BLANK</b></p>	<p style="text-align: center;"><b>BLANK</b></p>

**ILLUMINATIONS**

**Illuminations (6)**

**SD941-6**

**MEMO**

Digital Clock & Cigarette Lighter (Power Outlet) (1)

SD945-1

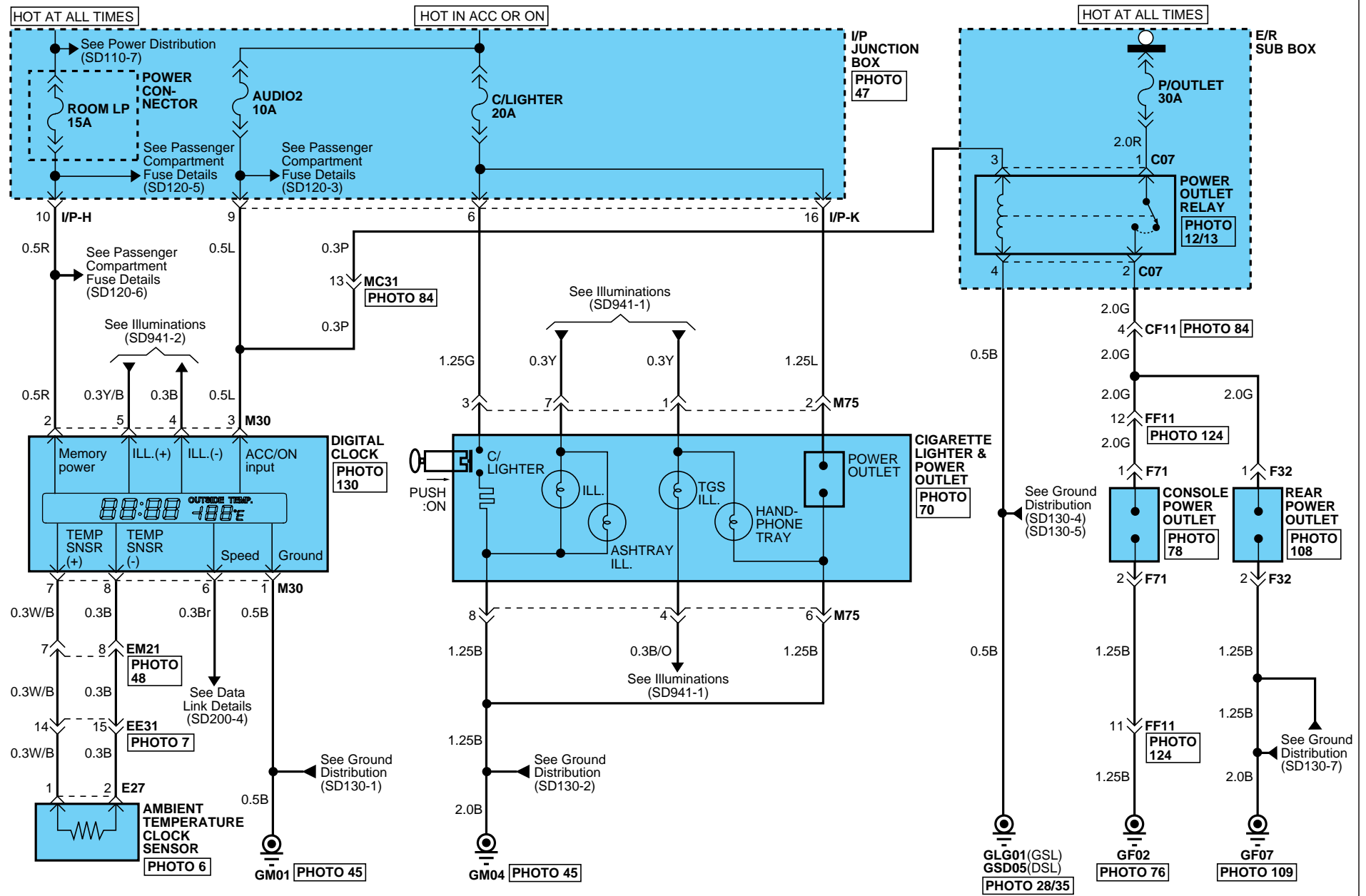

**DIGITAL CLOCK & CIGARETTE LIGHTER (POWER OUTLET)**

**Digital Clock & Cigarette Lighter (Power Outlet) (2)**

**SD945-2**

**C07**

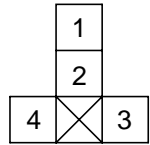

CR04F094

**E27**

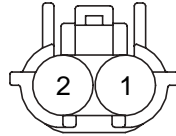

KET\_SWP\_02F\_B

**F32**

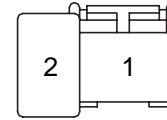

AMP\_PLM2\_02F\_B

**F71**

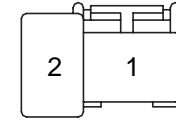

AMP\_PLM2\_02F\_W

**M30**

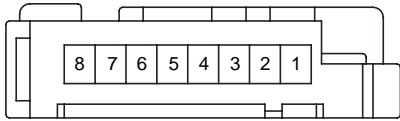

AMP\_MQS\_08F\_W

**M75**

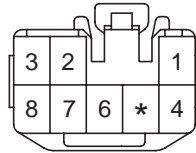

KET\_090II\_08F\_W

**BLANK**

**BLANK**



# BODY CONTROL MODULE (BCM) SYSTEM

## Body Control Module (BCM) System (2)

SD952-2

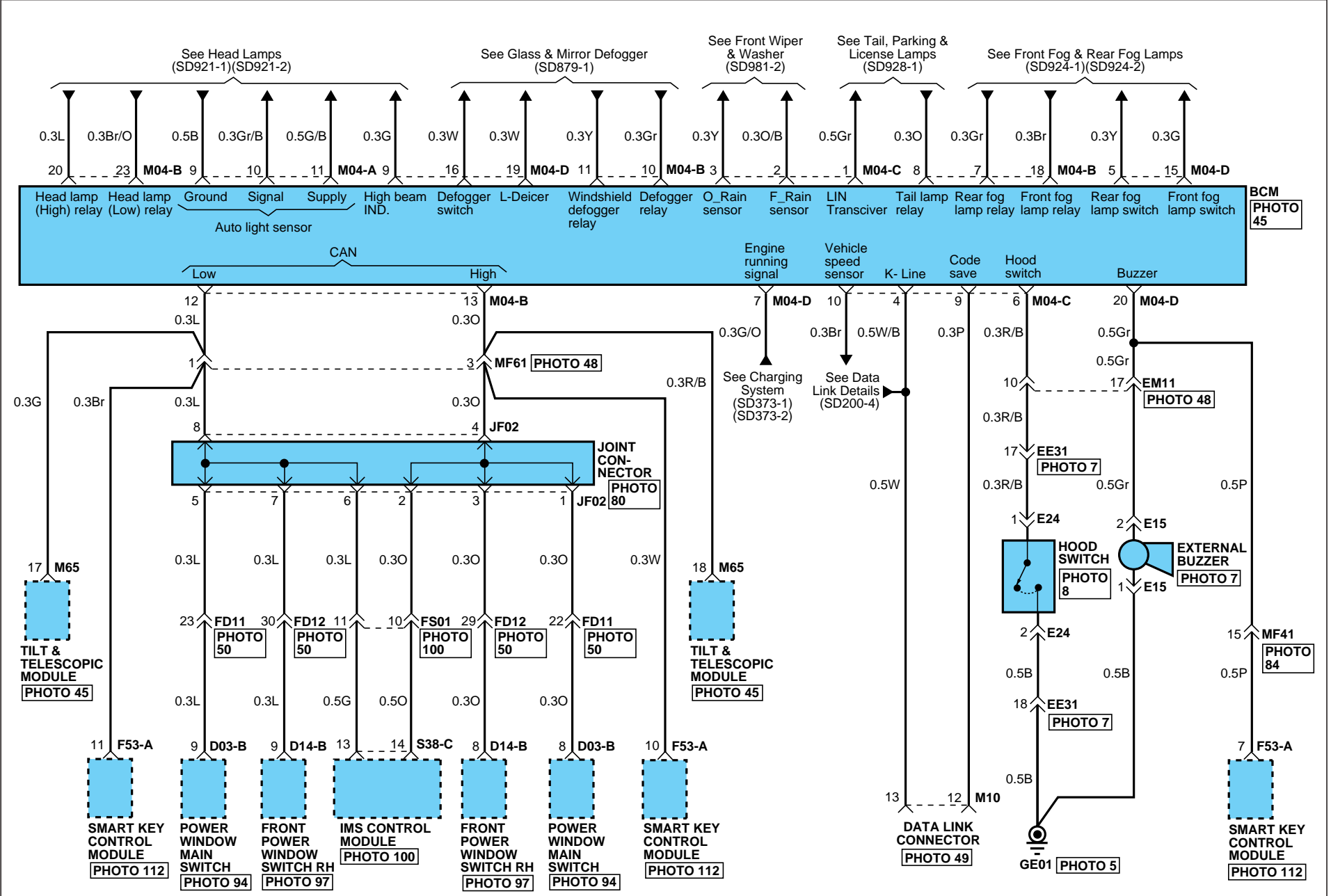

# BODY CONTROL MODULE (BCM) SYSTEM

## Body Control Module (BCM) System (3)

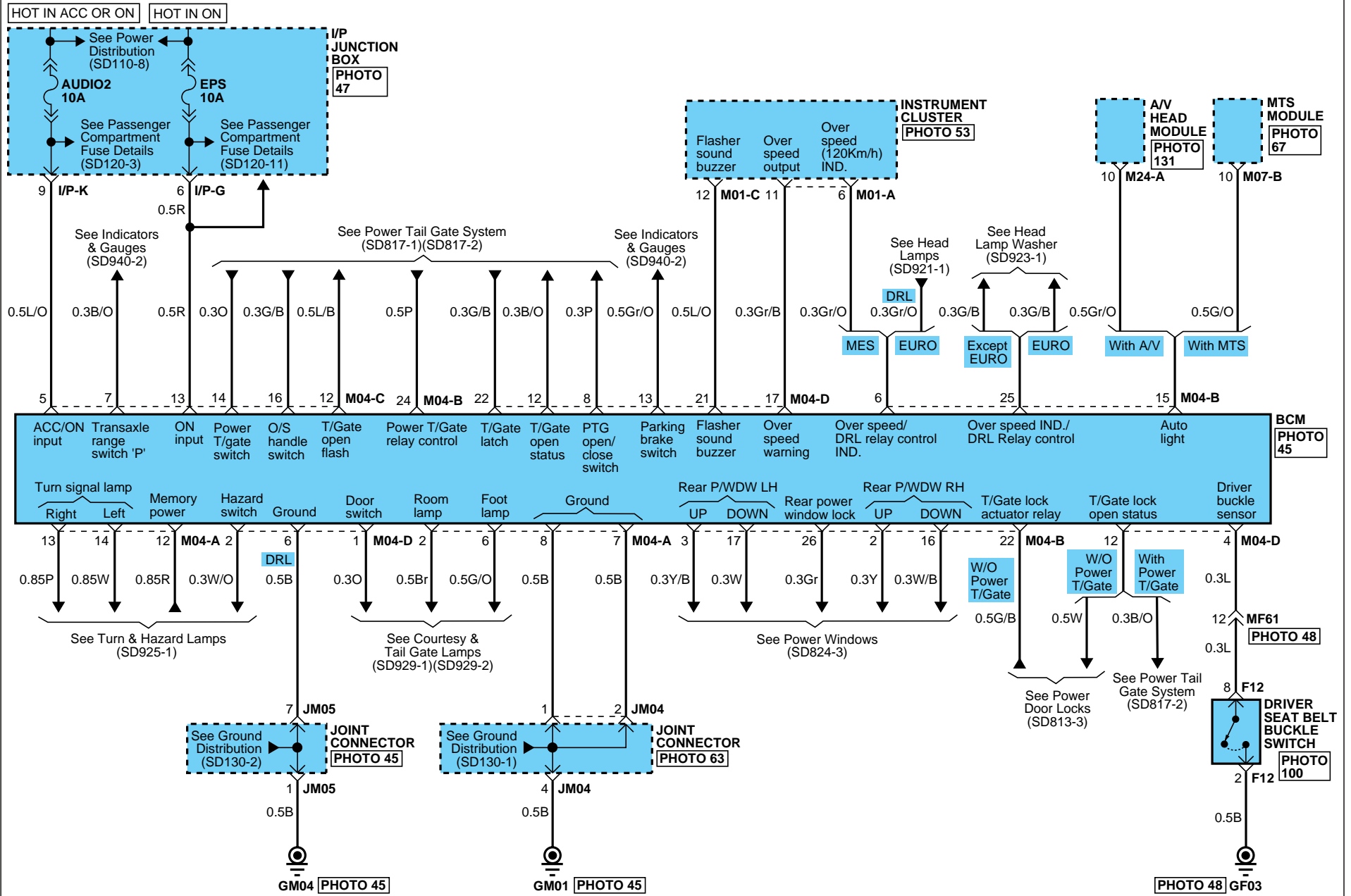

SD952-3



# BODY CONTROL MODULE (BCM) SYSTEM

## Body Control Module (BCM) System (4)

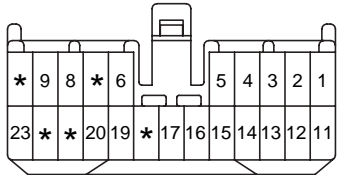
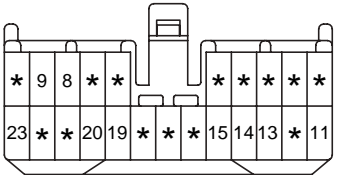
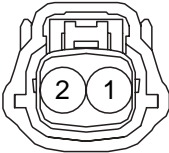
SD952-4

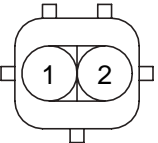
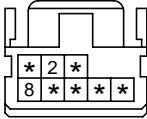
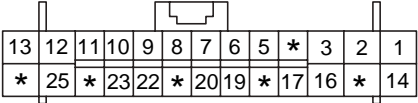
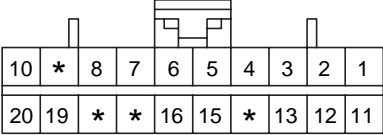
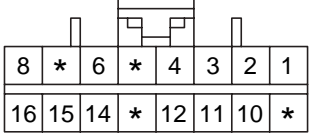
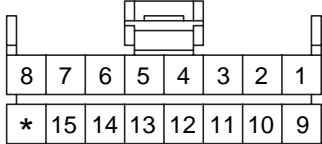
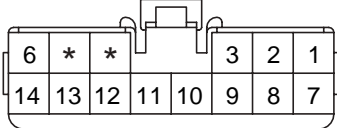
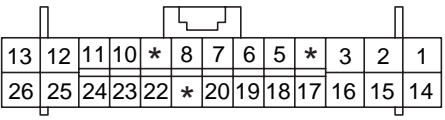
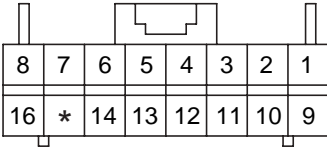
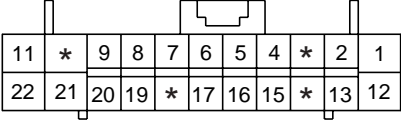
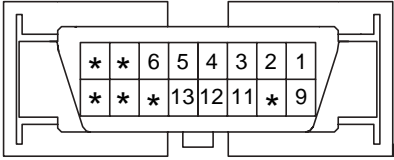
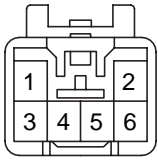
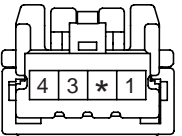
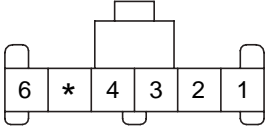
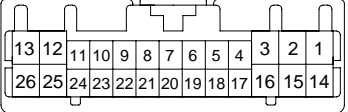
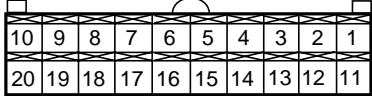
<p><b>D03-B</b></p>  <p>KET_050_23F_W</p>	<p><b>D14-B</b></p>  <p>KET_050_23F_W</p>	<p><b>E04</b></p>  <p>MLX_HORN_02F_B_FILT</p>	<p><b>E15</b></p>  <p>KET_090IWP_02F_B</p>
<p><b>E24</b></p>  <p>AMP_EJWP_02M_B</p>	<p><b>F12</b></p>  <p>JST_HIC_08F_Y</p>	<p><b>F53-A</b></p>  <p>AMP_0407_26F_W_HD</p>	<p><b>M01-A</b></p>  <p>AMP_040M2_20F_B</p>
<p><b>M01-B</b></p>  <p>AMP_040M2_16F_B</p>	<p><b>M01-C</b></p>  <p>AMP_040M1_16F_B</p>	<p><b>M04-A</b></p>  <p>KET_090II_14F_W</p>	<p><b>M04-B</b></p>  <p>AMP_0407_26F_Gr_HD</p>
<p><b>M04-C</b></p>  <p>AMP_0407_16F_W_040</p>	<p><b>M04-D</b></p>  <p>AMP_0407_22F_W_HD</p>	<p><b>M10</b></p>  <p>MLX_OBDII_16F_B_SIN</p>	<p><b>M28</b></p>  <p>KET_090II_06M_W</p>
<p><b>M54</b></p>  <p>KET_040III_04F_W</p>	<p><b>M58</b></p>  <p>KET_91A_06F_W</p>	<p><b>M65</b></p>  <p>KET_0407_26F_B</p>	<p><b>S38-C</b></p>  <p>CR20F021</p>



Immobilizer System (1)

W/O Smart Key

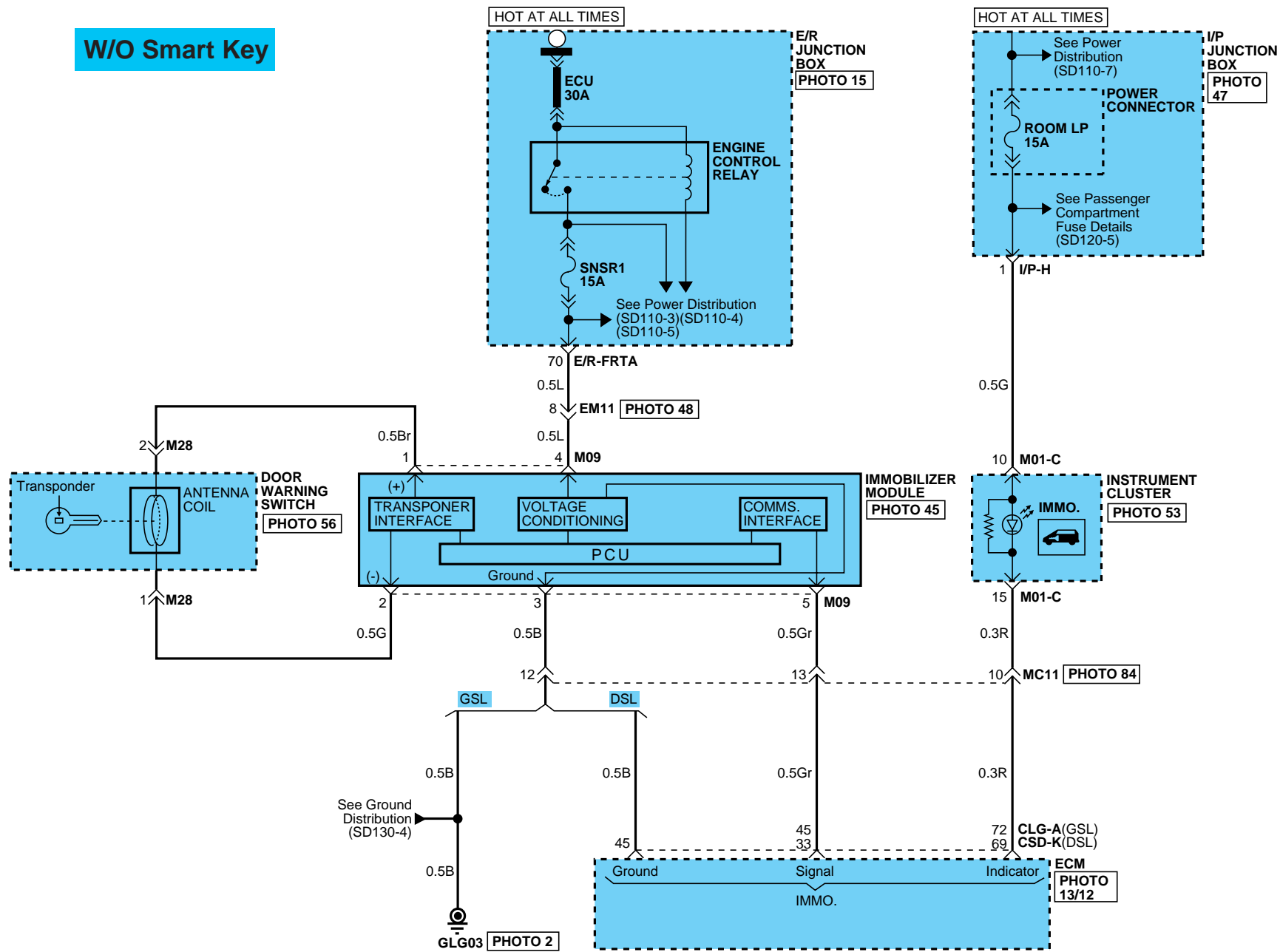

# IMMOBILIZER SYSTEM

## Immobilizer System (2)

SD954-2

CLG-A

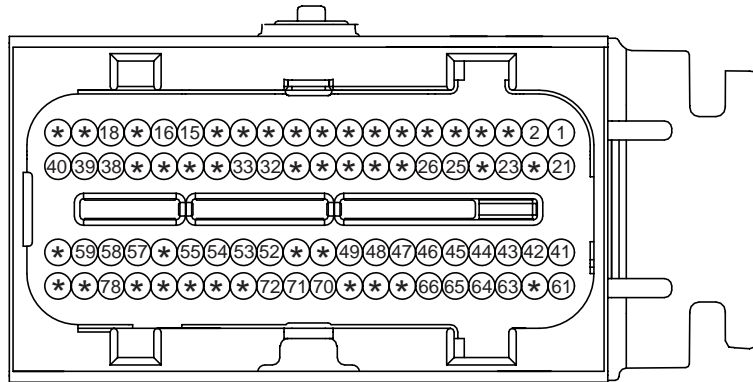

PKD\_ECU\_80F\_GR\_3

CSD-K

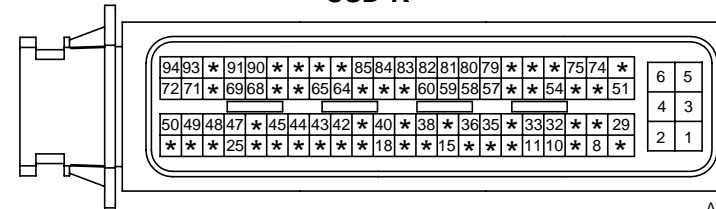

AMP\_ECU\_94F\_B

M01-C

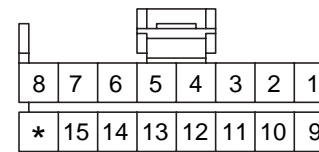

AMP\_040M1\_16F\_B

M09

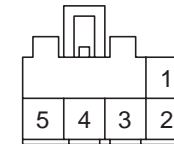

KUM\_CDR\_05F\_W

M28

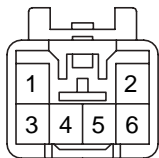

KET\_090II\_06M\_W

BLANK

BLANK

BLANK

Mobile Telematic System (MTS) (1)

SD955-1

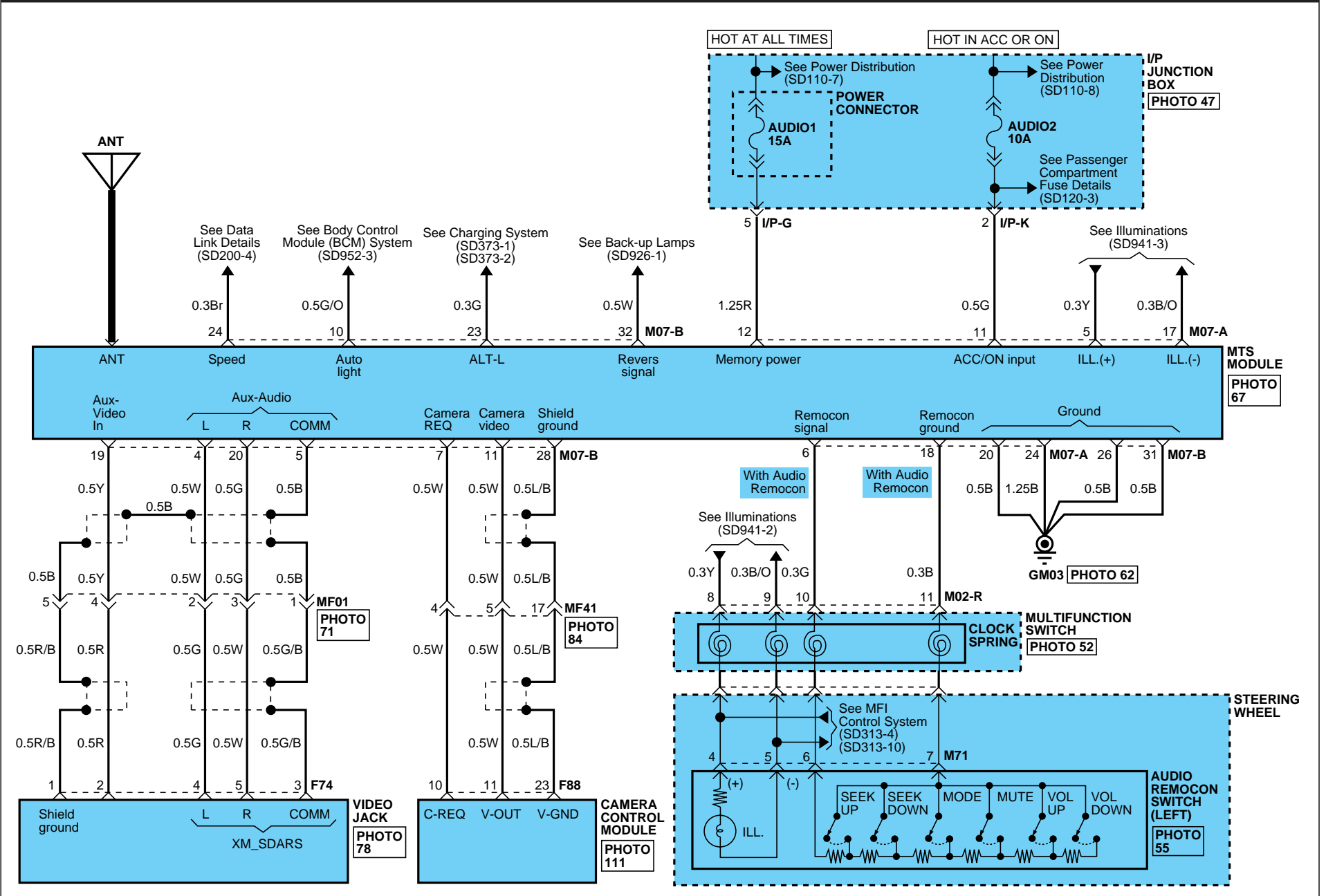



**MOBILE TELEMATIC SYSTEM (MTS)**

**Mobile Telematic System (MTS) (3)**

**SD955-3**

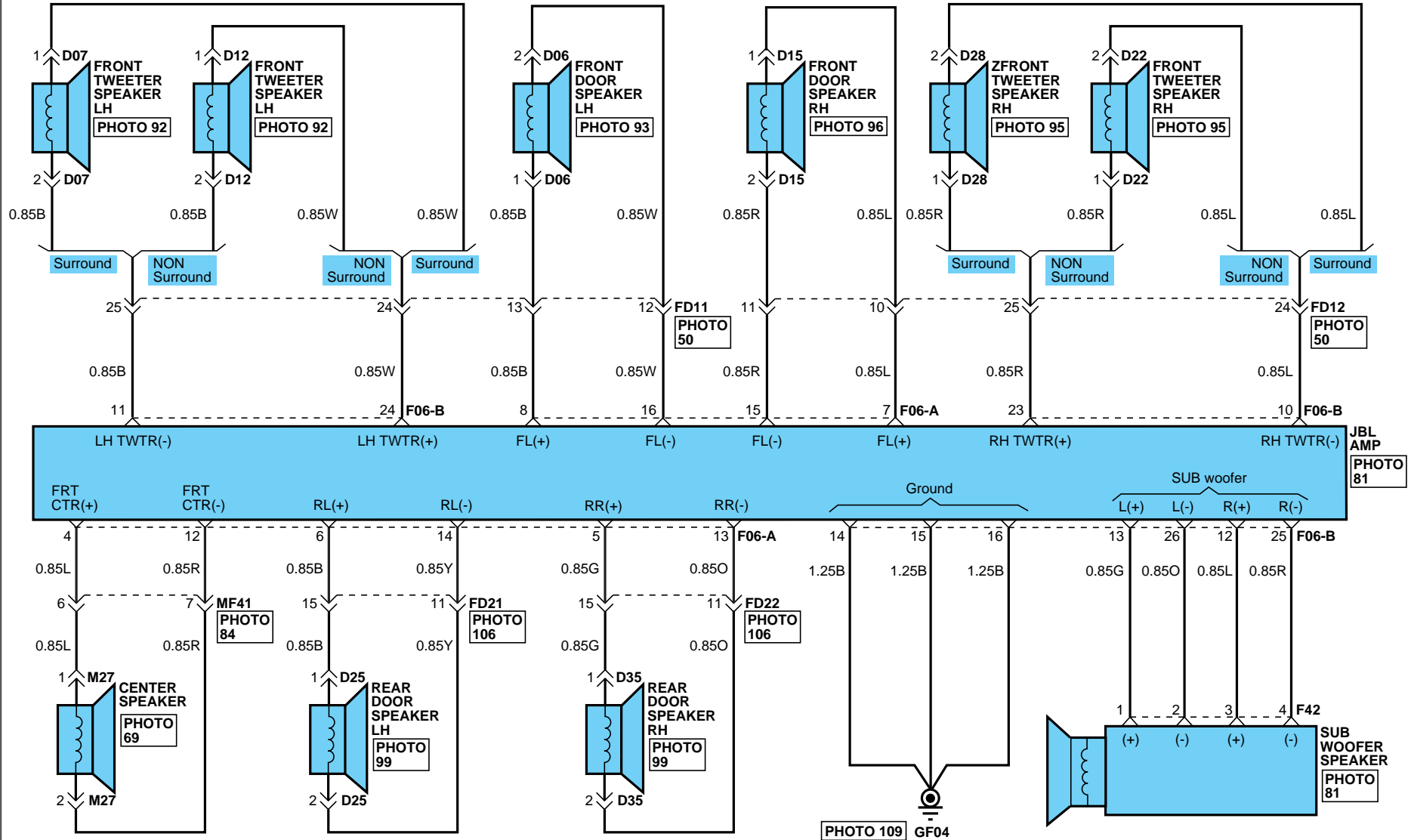

# MOBILE TELEMATIC SYSTEM (MTS)

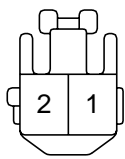
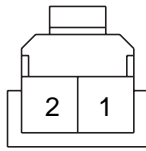
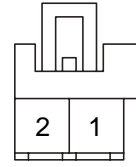
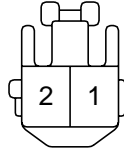
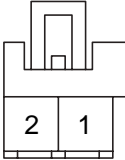
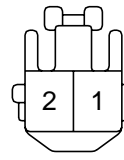
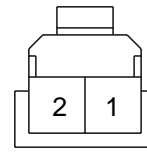
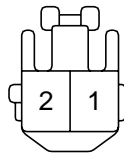
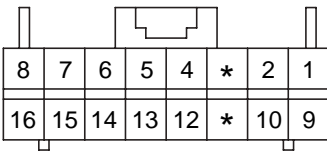
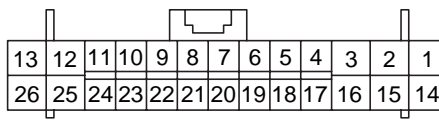
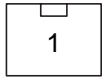
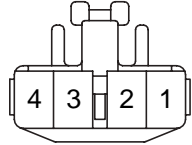
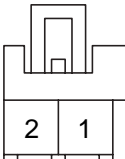
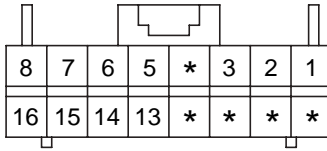
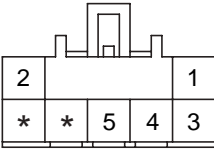
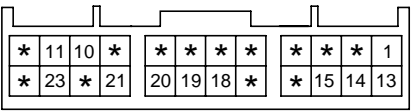
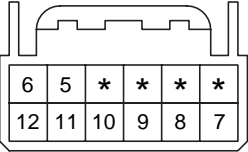
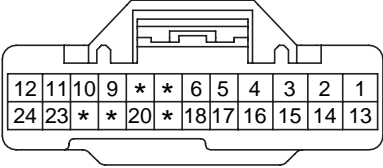
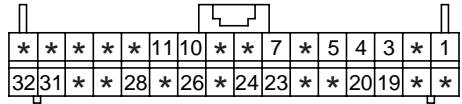
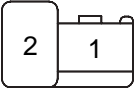
Mobile Telematic System (MTS) (4)			SD955-4
<p><b>D06</b></p>  <p>KET_090III_02F_W_L</p>	<p><b>D07</b></p>  <p>AMP_070_02F_W</p>	<p><b>D12</b></p>  <p>KUM_CDR_02F_W</p>	<p><b>D15</b></p>  <p>KET_090III_02F_W_L</p>
<p><b>D22</b></p>  <p>KUM_CDR_02F_W</p>	<p><b>D25</b></p>  <p>KET_090III_02F_W_L</p>	<p><b>D28</b></p>  <p>AMP_070_02F_W</p>	<p><b>D35</b></p>  <p>KET_090III_02F_W_L</p>
<p><b>F06-A</b></p>  <p>AMP_0407MII_16F_GY</p>	<p><b>F06-B</b></p>  <p>AMP_0407MII_26F_GY</p>	<p><b>F31</b></p>  <p>AMP_PLM1_01F_B</p>	<p><b>F42</b></p>  <p>AMP_090III_04F_W</p>
<p><b>F45</b></p>  <p>KUM_CDR_02F_W</p>	<p><b>F49-B</b></p>  <p>AMP_0407_16F_W_040</p>	<p><b>F74</b></p>  <p>KUM_CDR_07F_L</p>	<p><b>F88</b></p>  <p>AMP_040II_24F_B</p>
<p><b>M02-R</b></p>  <p>AMP_025_12F_W</p>	<p><b>M07-A</b></p>  <p>KET_0409_24F_W</p>	<p><b>M07-B</b></p>  <p>AMP_025_32F_W</p>	<p><b>M27</b></p>  <p>AMP_PLM2_02F_B</p>

# MOBILE TELEMATIC SYSTEM (MTS)

## Mobile Telematic System (MTS) (5)

SD955-5

M71

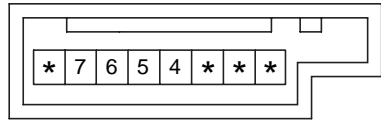

AMP\_1743386-2

R17

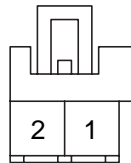

KUM\_CDR\_02F\_W

R23

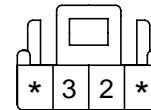

KET\_SP\_04F\_W

BLANK

**MOBILE TELEMATIC SYSTEM (MTS)**

**Mobile Telematic System (MTS) (6)**

**SD955-6**

**MEMO**



Tire Pressure Monitoring System (TPMS) (1)

SD956-1

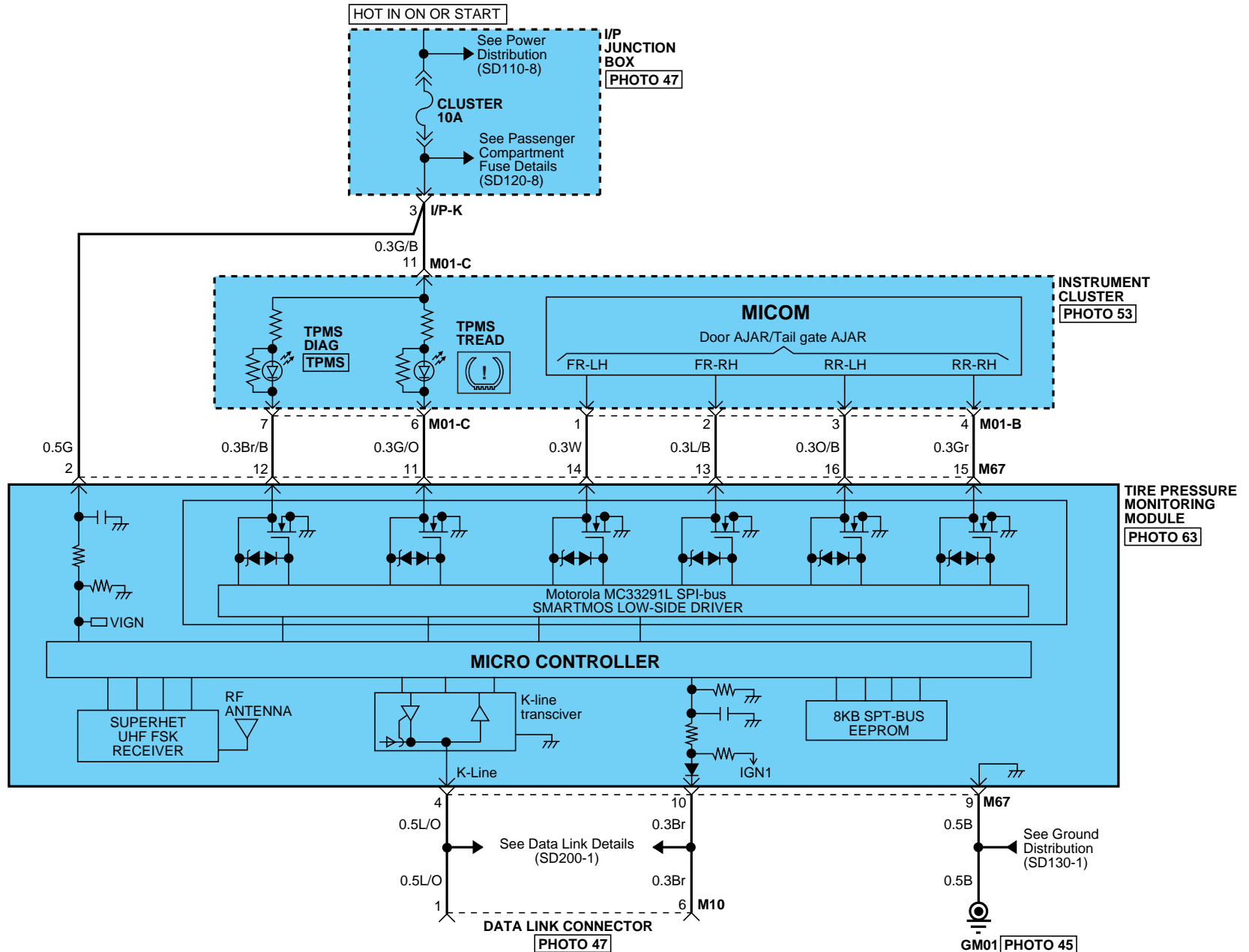

# TIRE PRESSURE MONITORING SYSTEM (TPMS)

## Tire Pressure Monitoring System (TPMS) (2)

SD956-2

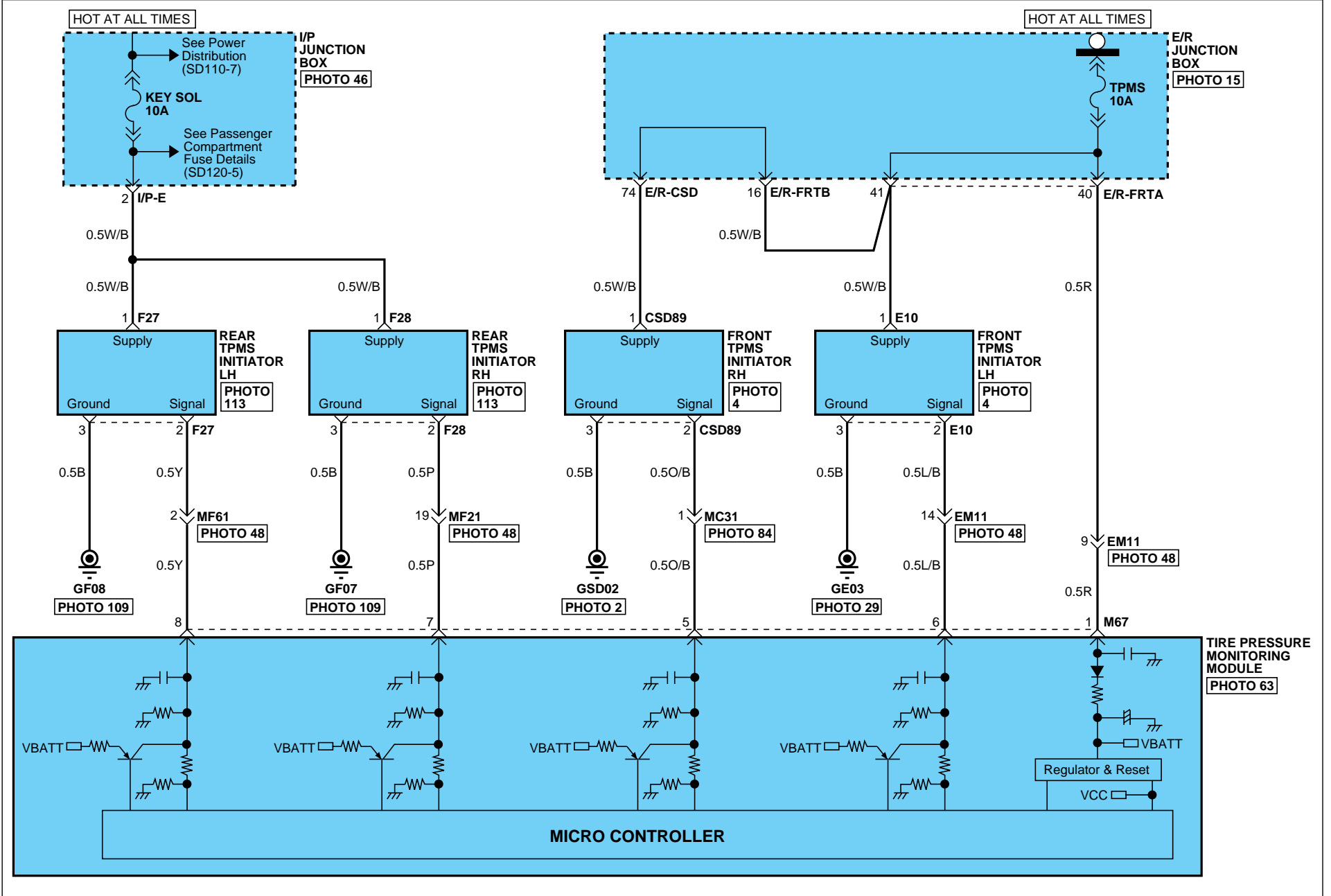

# TIRE PRESSURE MONITORING SYSTEM (TPMS)

## Tire Pressure Monitoring System (TPMS) (3)

SD956-3

**CSD89**

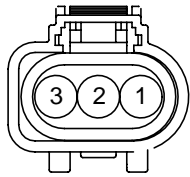

AMP\_MT11\_03F\_B

**E10**

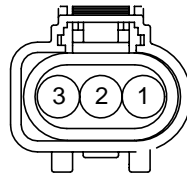

AMP\_MT11\_03F\_B

**F27**

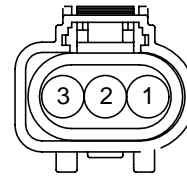

AMP\_MT11\_03F\_B

**F28**

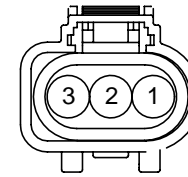

AMP\_MT11\_03F\_B

**M01-B**

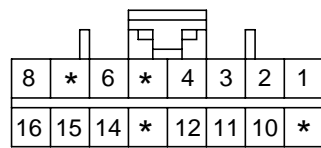

AMP\_040M2\_16F\_B

**M01-C**

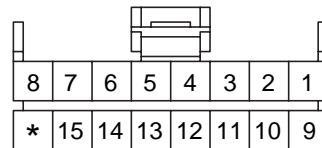

AMP\_040M1\_16F\_B

**M10**

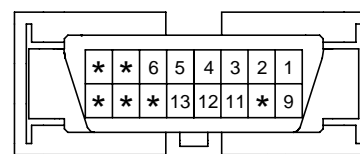

MLX\_080II\_16F\_B\_SIN

**M67**

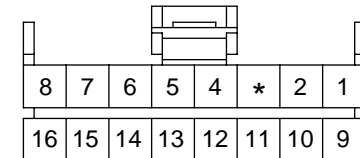

AMP\_040M1\_16F\_B

# TIRE PRESSURE MONITORING SYSTEM (TPMS)

Tire Pressure Monitoring System (TPMS) (4)

SD956-4

MEMO

Rear Parking Assist System (1)

SD957-1

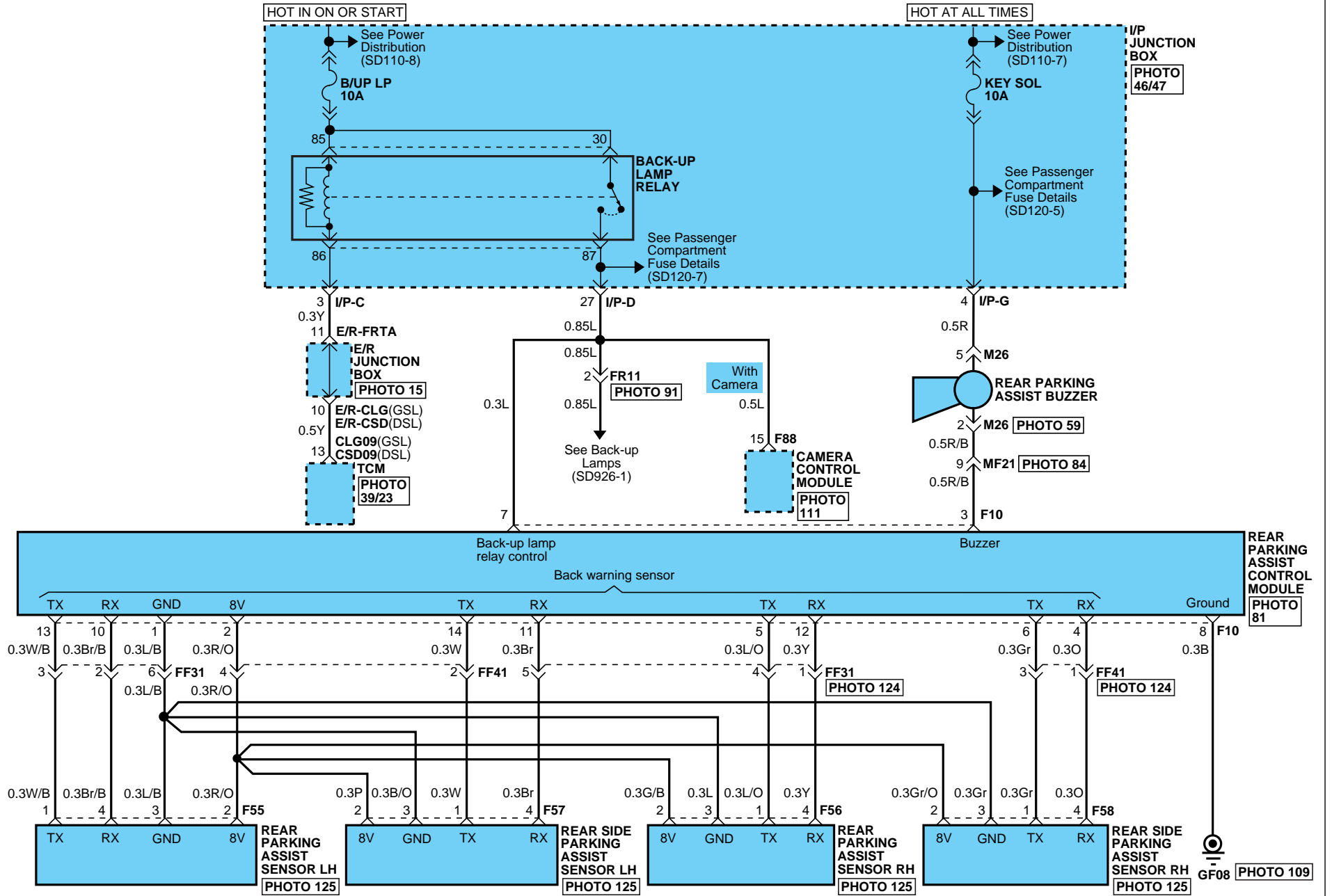

# REAR PARKING ASSIST SYSTEM

## Rear Parking Assist System (2)

SD957-2

**CLG09**

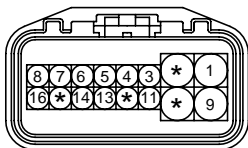

YAZ\_TCMWP\_16F\_B

**CSD09**

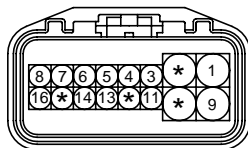

YAZ\_TCMWP\_16F\_B

**F10**

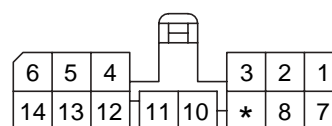

KET\_070\_14F\_W

**F55**

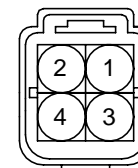

MLX\_060WP\_04F\_B

**F56**

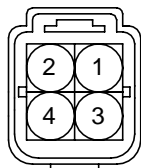

MLX\_060WP\_04F\_B

**F57**

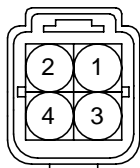

MLX\_060WP\_04F\_B

**F58**

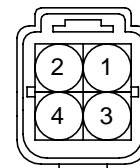

MLX\_060WP\_04F\_B

**M26**

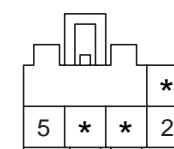

KUM\_CDR\_05F\_W

Back Warning Camera (1)

SD957-3

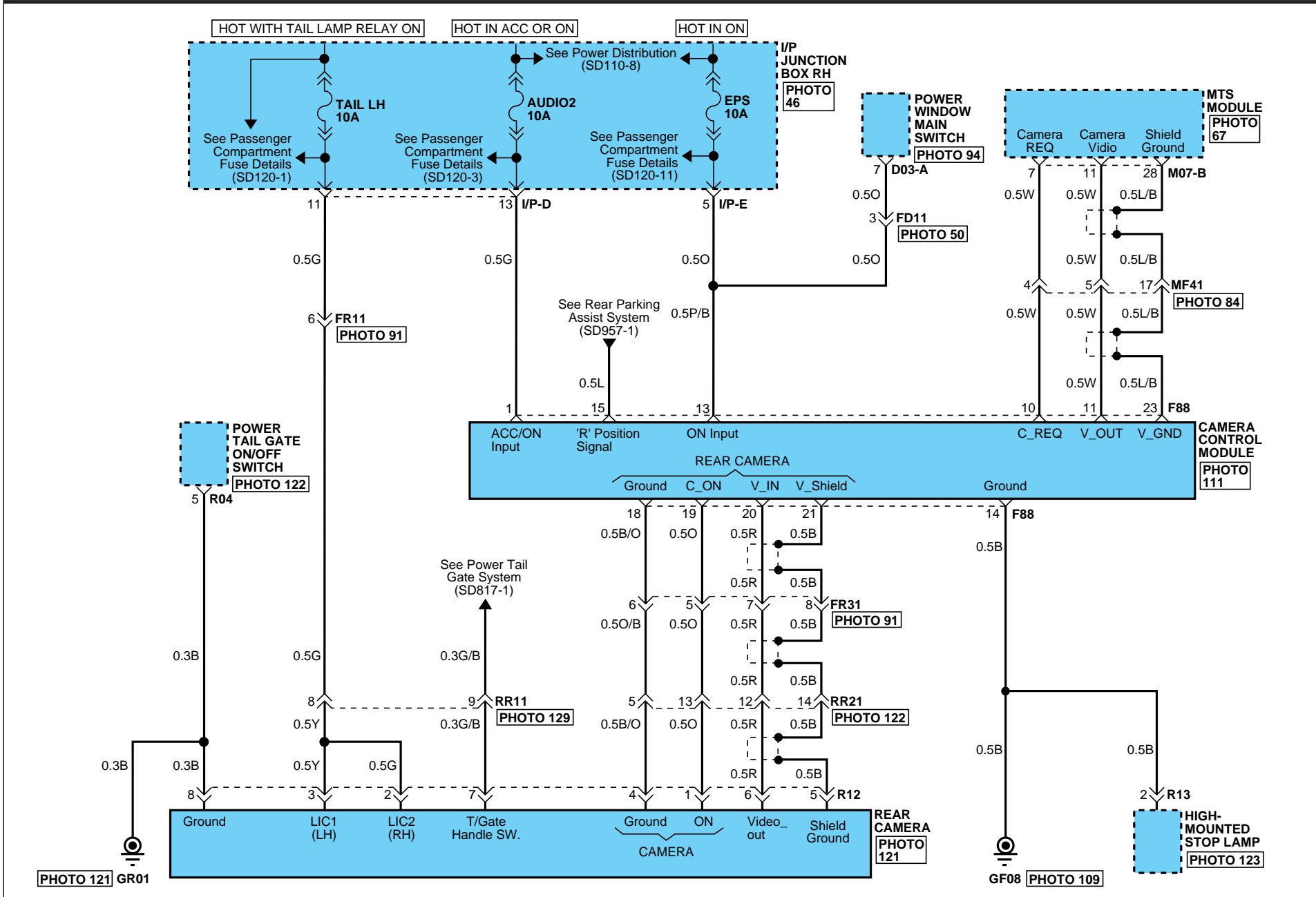

# BACK WARNING CAMERA

## Back Warning Camera (2)

SD957-4

**D03-A**

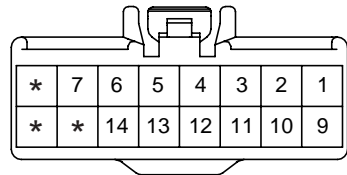

KET\_090III\_16F\_Y

**M07-B**

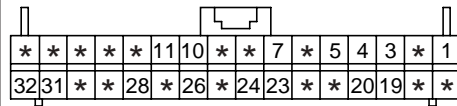

AMP\_025\_32F\_W

**F88**

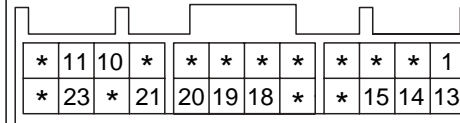

AMP\_040II\_24F\_B

**R04**

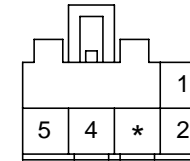

KUM\_CDR\_05F\_W

**R12**

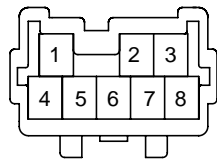

KET\_070\_8M\_W

**R13**

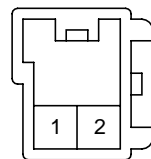

KUM-CDR\_02M\_W

**BLANK**

**BLANK**



Audio (1)

SD961-1

**W/O PLATFORM AUDIO & WITH AMP SPEAKER**

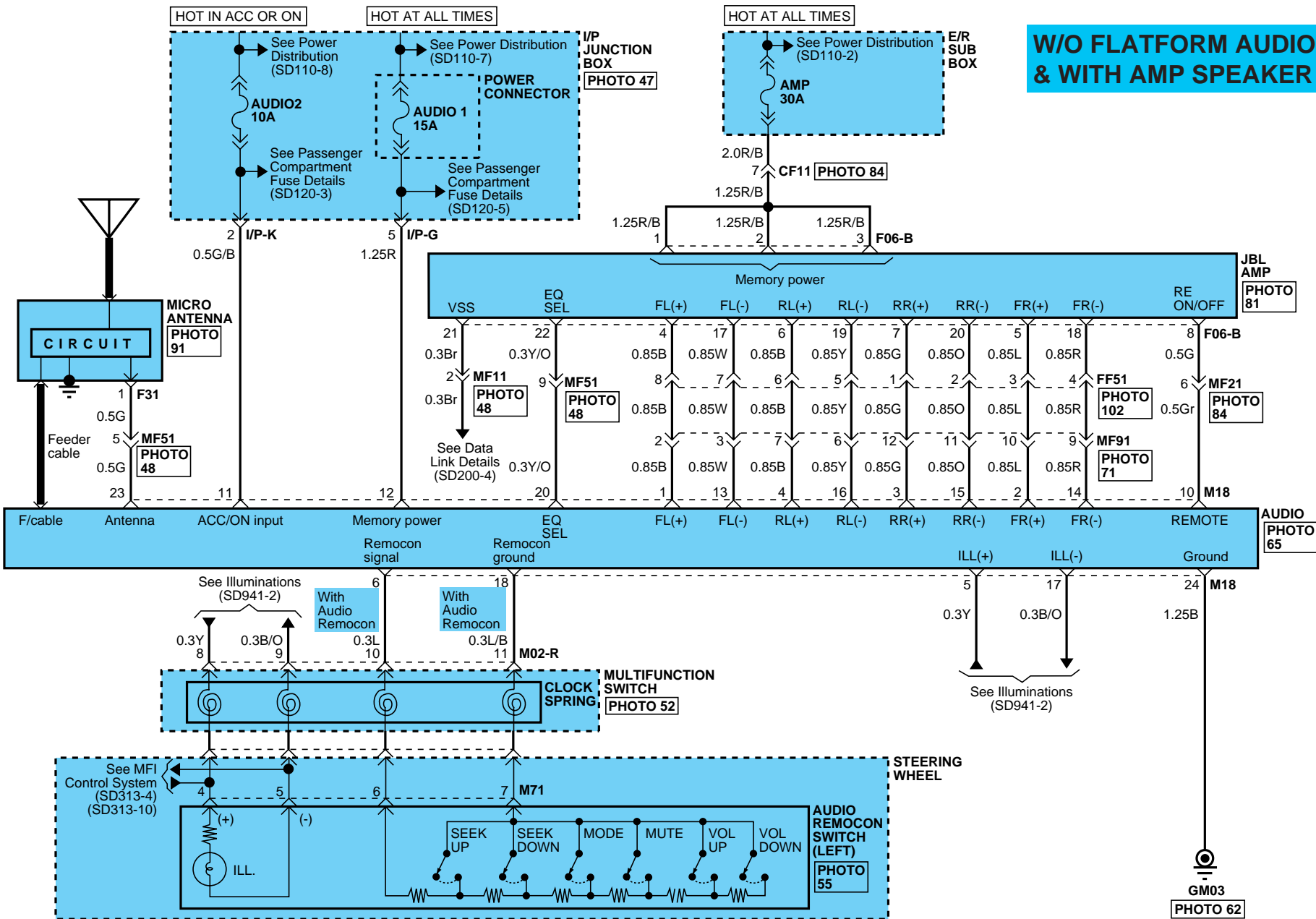

# AUDIO

## Audio (2)

SD961-2

**W/O FLATM AUDIO  
& WITH AMP SPEAKER**

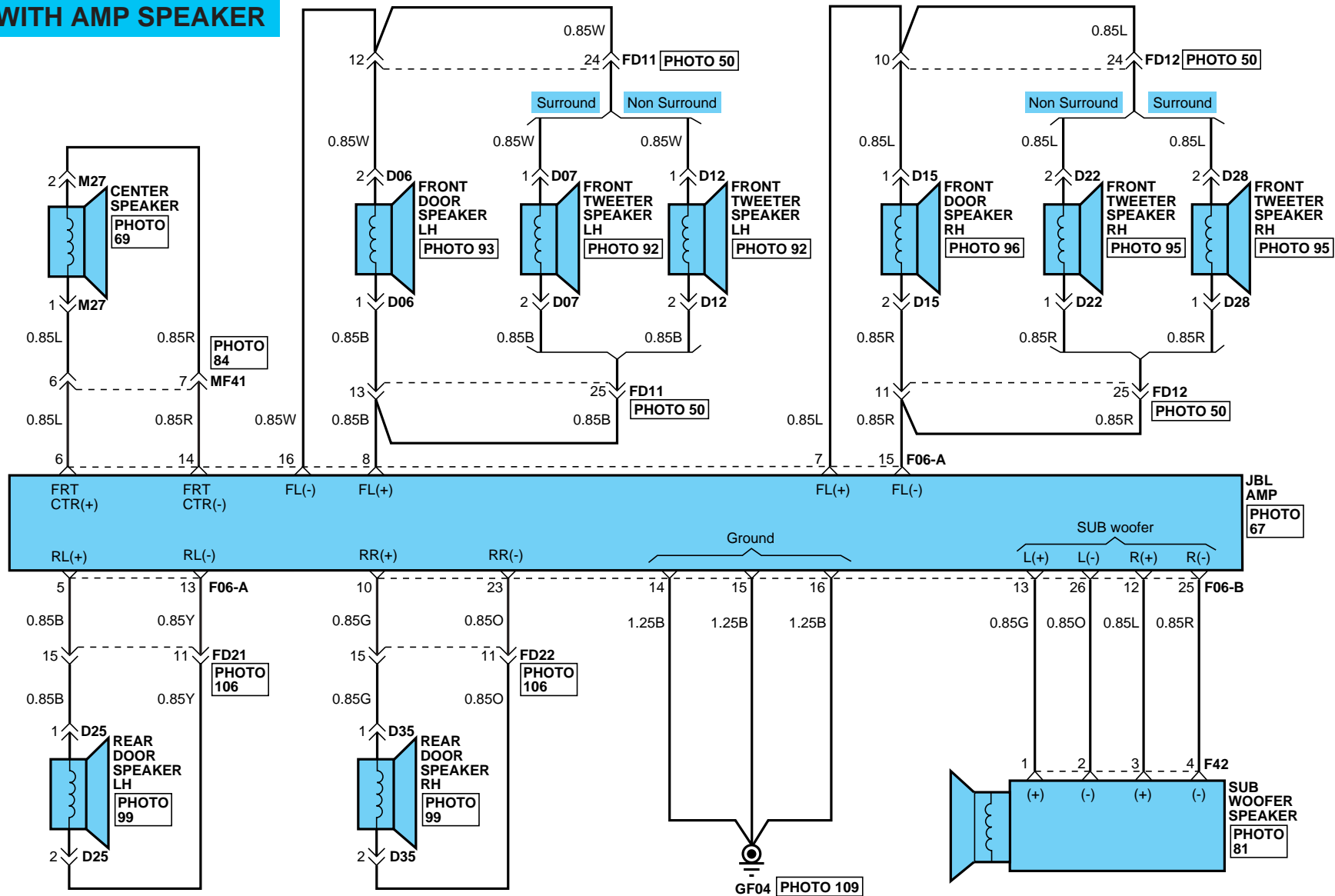

# AUDIO

## Audio (3)

SD961-3

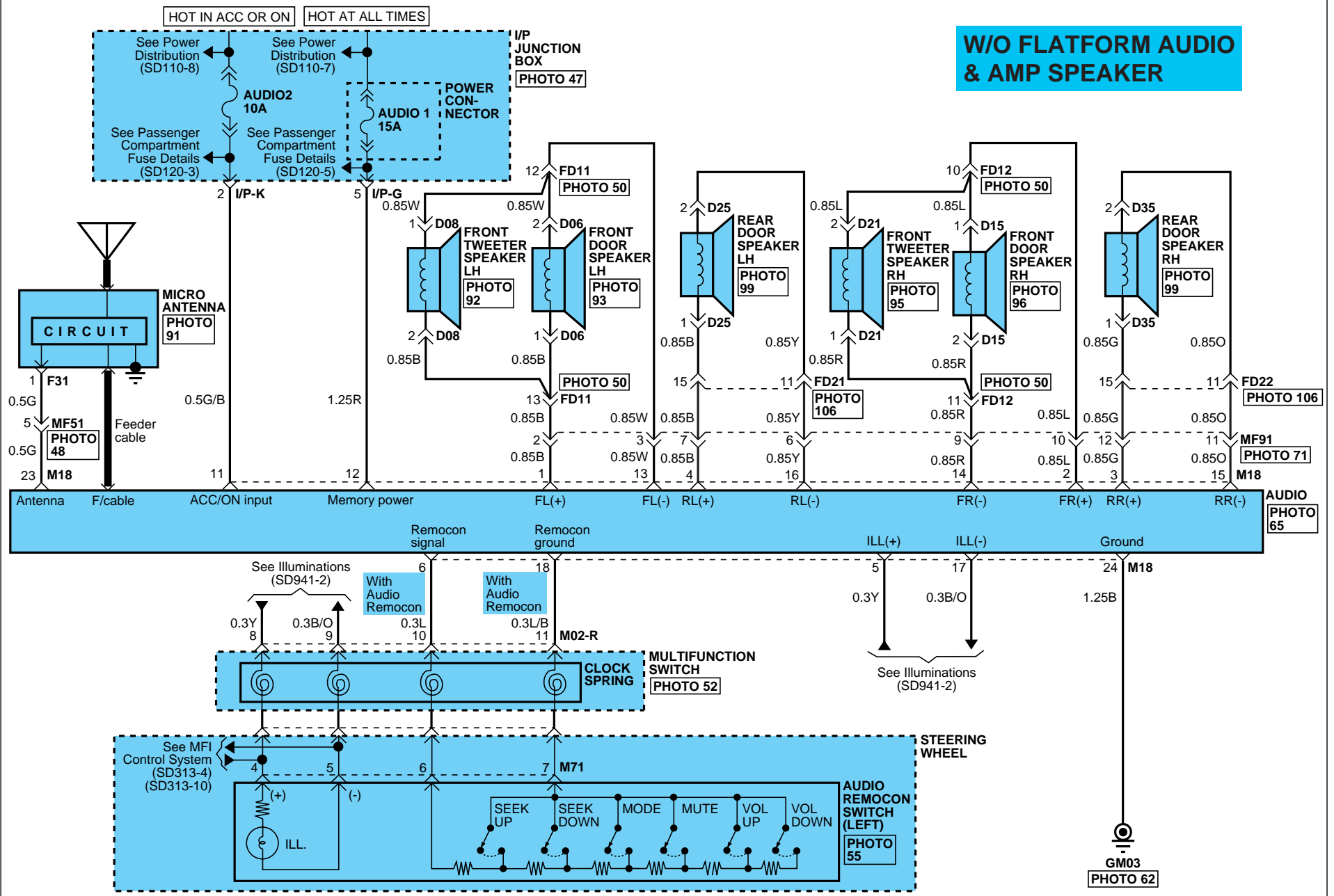

# AUDIO

## Audio (4)

SD961-4

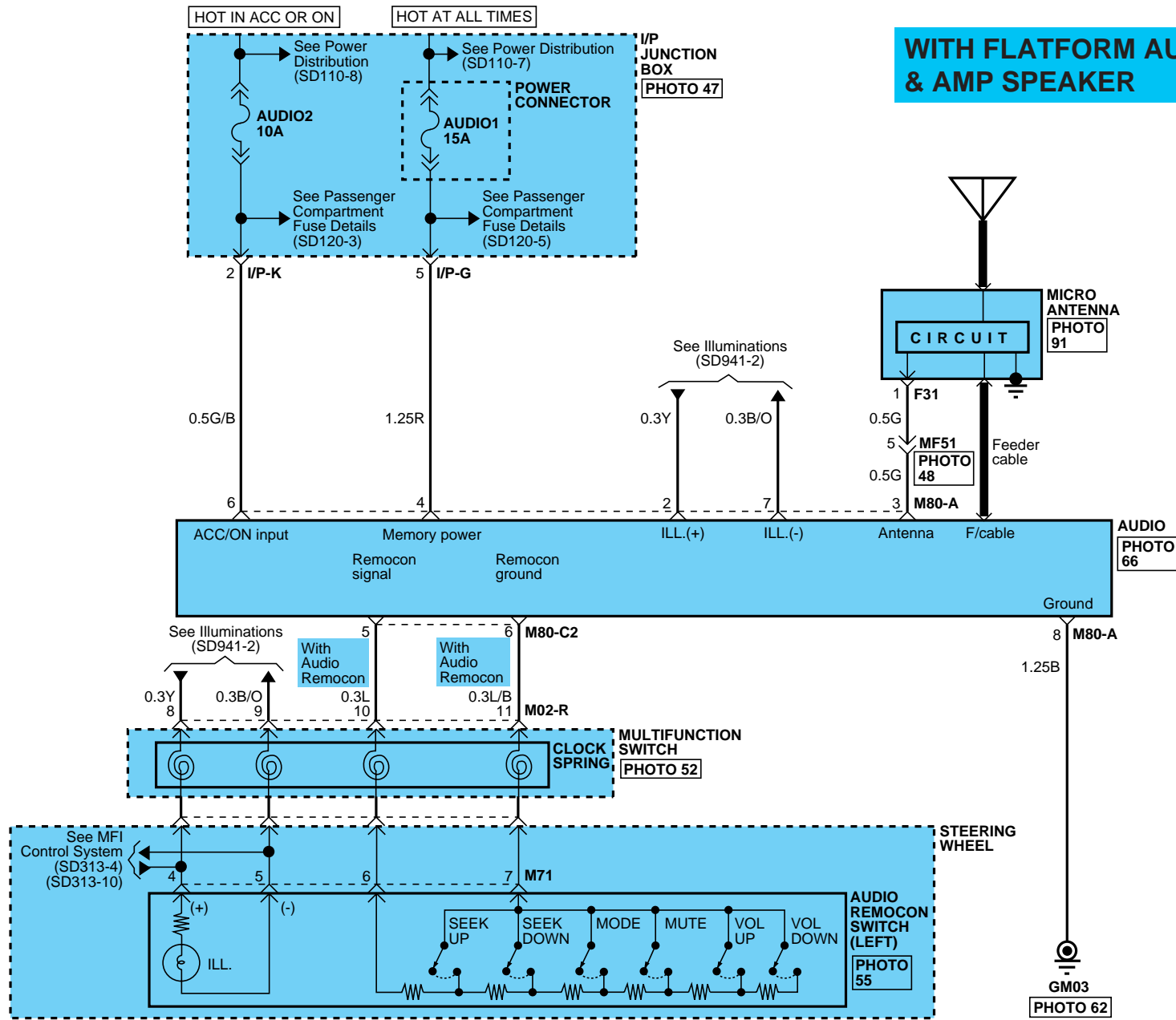

# AUDIO

## Audio (5)

SD961-5

**WITH PLATFORM AUDIO & AMP SPEAKER**

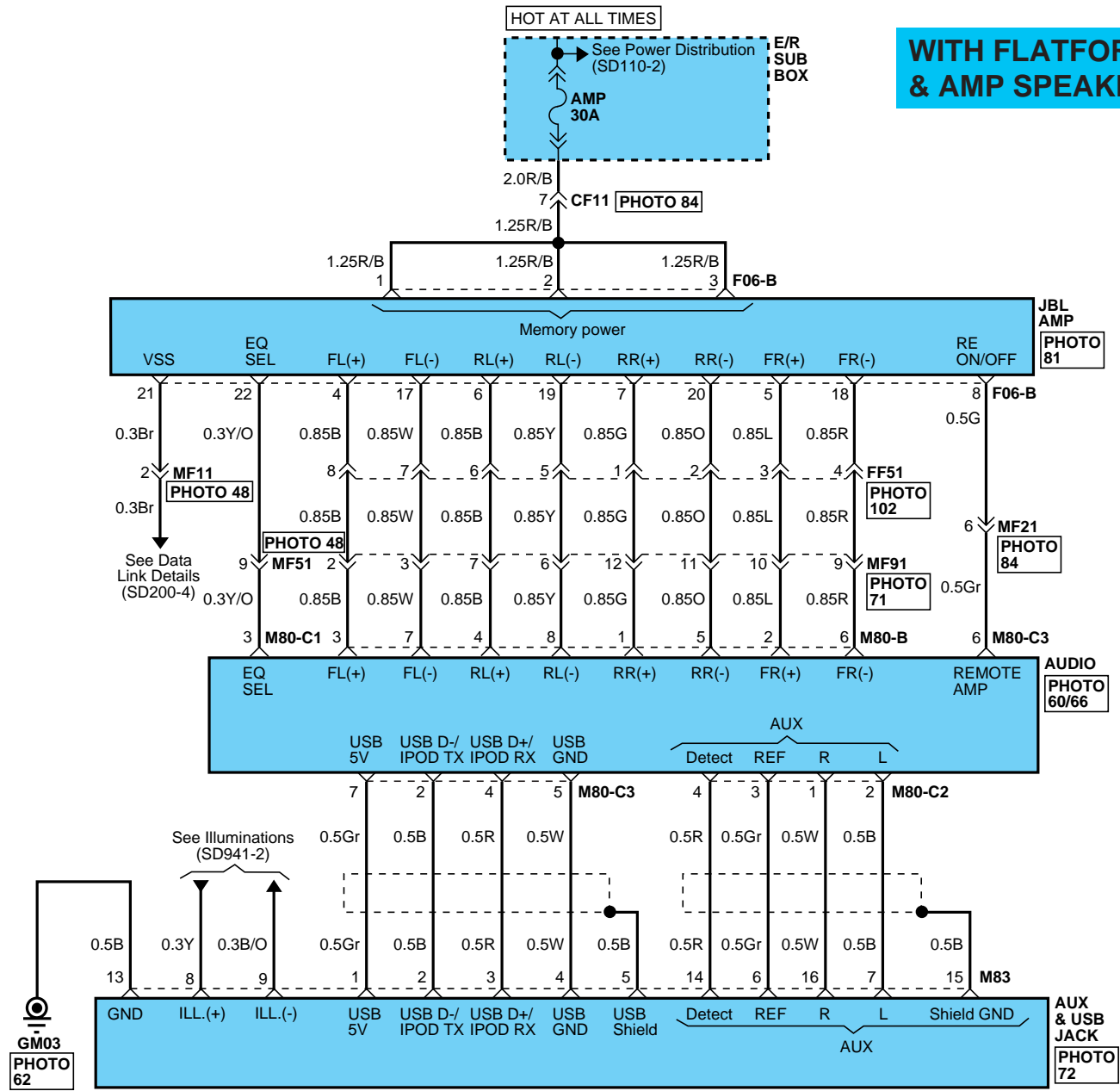

**WITH PLATFORM AUDIO & AMP SPEAKER**

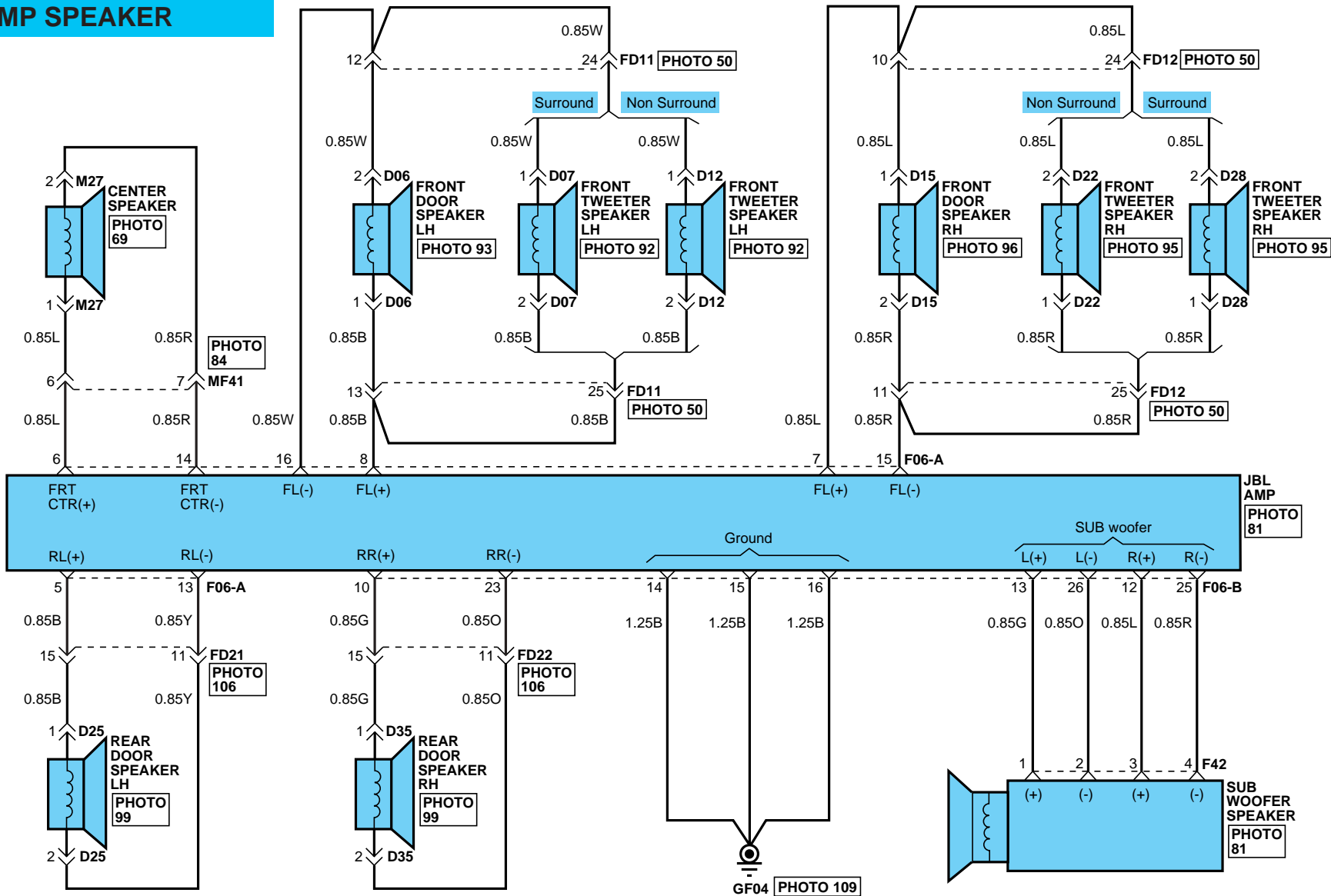

# AUDIO

## Audio (7)

SD961-7

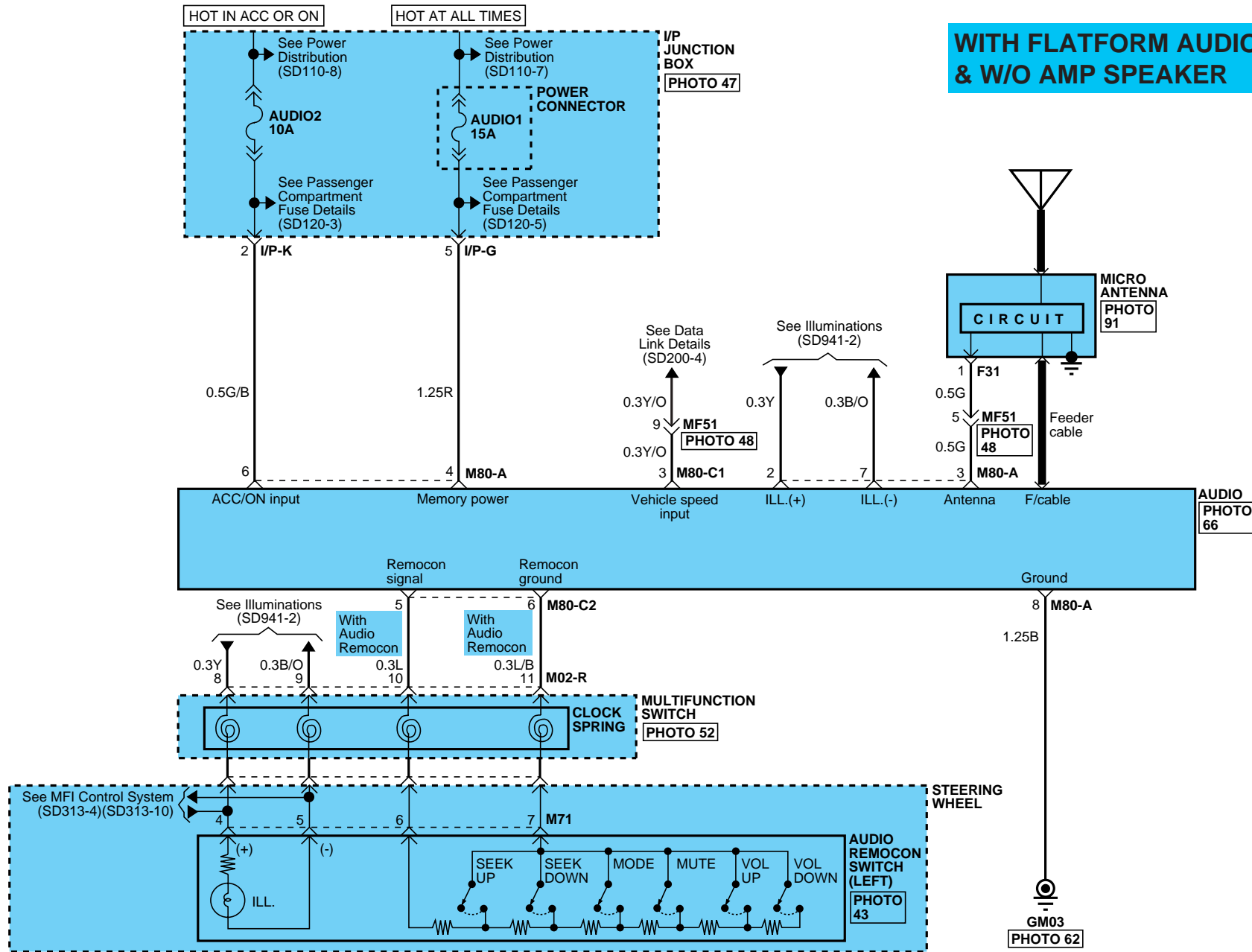

# AUDIO

## Audio (8)

SD961-8

**WITH PLATFORM AUDIO  
& W/O AMP SPEAKER**

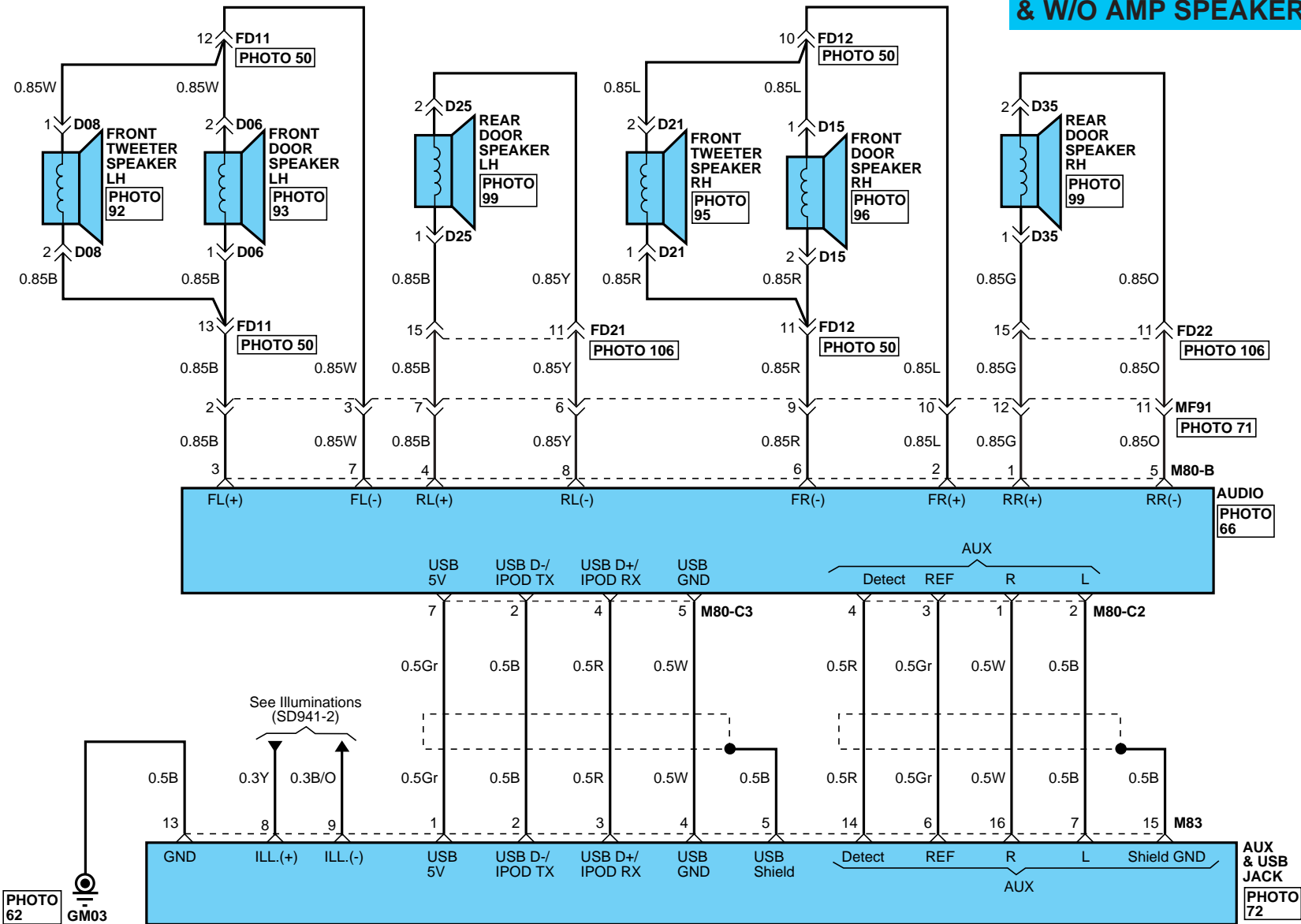

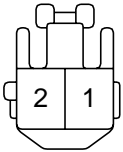
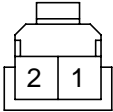
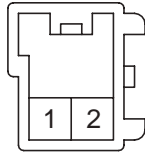
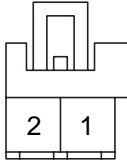
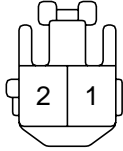
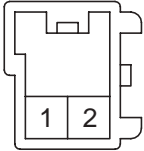
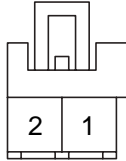
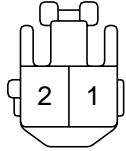
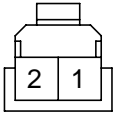
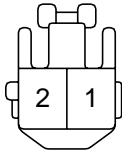
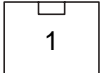
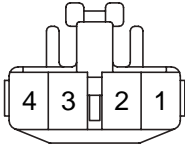
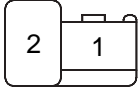
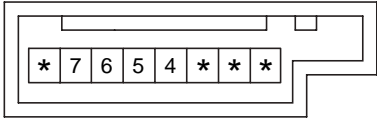

# AUDIO

Audio (9)			SD961-9																																										
<p><b>D06</b></p>  <p>KET_090III_02F_W_L</p>	<p><b>D07</b></p>  <p>AMP_070_02F_W</p>	<p><b>D08</b></p>  <p>KUM_CDR_02M_W</p>	<p><b>D12</b></p>  <p>KUM_CDR_02F_W</p>																																										
<p><b>D15</b></p>  <p>KET_090III_02F_W_L</p>	<p><b>D21</b></p>  <p>KUM_CDR_02M_W</p>	<p><b>D22</b></p>  <p>KUM_CDR_02F_W</p>	<p><b>D25</b></p>  <p>KET_090III_02F_W_L</p>																																										
<p><b>D28</b></p>  <p>AMP_070_02F_W</p>	<p><b>D35</b></p>  <p>KET_090III_02F_W_L</p>	<p><b>F06-A</b></p> <table border="1" data-bbox="1182 799 1509 943"> <tr> <td>8</td><td>7</td><td>6</td><td>5</td><td>4</td><td>*</td><td>2</td><td>1</td> </tr> <tr> <td>16</td><td>15</td><td>14</td><td>13</td><td>12</td><td>*</td><td>10</td><td>9</td> </tr> </table> <p>AMP_0407II_16F_GY</p>	8	7	6	5	4	*	2	1	16	15	14	13	12	*	10	9	<p><b>F06-B</b></p> <table border="1" data-bbox="1606 815 2047 927"> <tr> <td>13</td><td>12</td><td>11</td><td>10</td><td>9</td><td>8</td><td>7</td><td>6</td><td>5</td><td>4</td><td>3</td><td>2</td><td>1</td> </tr> <tr> <td>26</td><td>25</td><td>24</td><td>23</td><td>22</td><td>21</td><td>20</td><td>19</td><td>18</td><td>17</td><td>16</td><td>15</td><td>14</td> </tr> </table> <p>AMP_0407MII_26F_GY</p>	13	12	11	10	9	8	7	6	5	4	3	2	1	26	25	24	23	22	21	20	19	18	17	16	15	14
8	7	6	5	4	*	2	1																																						
16	15	14	13	12	*	10	9																																						
13	12	11	10	9	8	7	6	5	4	3	2	1																																	
26	25	24	23	22	21	20	19	18	17	16	15	14																																	
<p><b>F31</b></p>  <p>AMP_PLM1_01F_B</p>	<p><b>F42</b></p>  <p>AMP_090II_04F_W</p>	<p><b>M02-R</b></p> <table border="1" data-bbox="1225 1054 1471 1203"> <tr> <td>6</td><td>5</td><td>*</td><td>*</td><td>*</td><td>*</td> </tr> <tr> <td>12</td><td>11</td><td>10</td><td>9</td><td>8</td><td>7</td> </tr> </table> <p>AMP_025_12F_W</p>	6	5	*	*	*	*	12	11	10	9	8	7	<p><b>M18</b></p> <table border="1" data-bbox="1637 1046 2020 1203"> <tr> <td>12</td><td>11</td><td>10</td><td>*</td><td>*</td><td>*</td><td>6</td><td>5</td><td>4</td><td>3</td><td>2</td><td>1</td> </tr> <tr> <td>24</td><td>23</td><td>*</td><td>*</td><td>20</td><td>*</td><td>18</td><td>17</td><td>16</td><td>15</td><td>14</td><td>13</td> </tr> </table> <p>KET_0409_24F_W</p>	12	11	10	*	*	*	6	5	4	3	2	1	24	23	*	*	20	*	18	17	16	15	14	13						
6	5	*	*	*	*																																								
12	11	10	9	8	7																																								
12	11	10	*	*	*	6	5	4	3	2	1																																		
24	23	*	*	20	*	18	17	16	15	14	13																																		
<p><b>M27</b></p>  <p>AMP_PLM2_02F_B</p>	<p><b>M71</b></p>  <p>AMP_1743386-2</p>	<p><b>M80-A</b></p> <table border="1" data-bbox="1247 1350 1464 1445"> <tr> <td>4</td><td>3</td><td>2</td><td>1</td> </tr> <tr> <td>8</td><td>7</td><td>6</td><td>*</td> </tr> </table> <p>AMP_AUDIO_08F_Gr_D2</p>	4	3	2	1	8	7	6	*	<p><b>M80-B</b></p> <table border="1" data-bbox="1720 1334 1935 1430"> <tr> <td>4</td><td>3</td><td>2</td><td>1</td> </tr> <tr> <td>8</td><td>7</td><td>6</td><td>5</td> </tr> </table> <p>AMP_AUDIO_08F_Br_D1</p>	4	3	2	1	8	7	6	5																										
4	3	2	1																																										
8	7	6	*																																										
4	3	2	1																																										
8	7	6	5																																										

# AUDIO

## Audio (10)

SD961-10

M80-C1

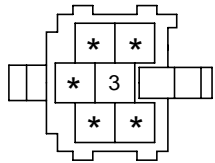

AMP\_AUDIO\_06F\_Y\_C1

M80-C2

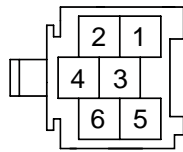

AMP\_AUDIO\_06F\_G\_C2

M80-C3

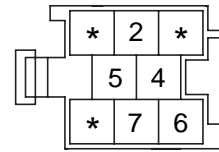

AMP\_AUDIO\_08F\_L\_C2

M83

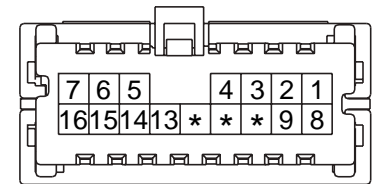

KET\_040III\_16F\_R

Horns (1)

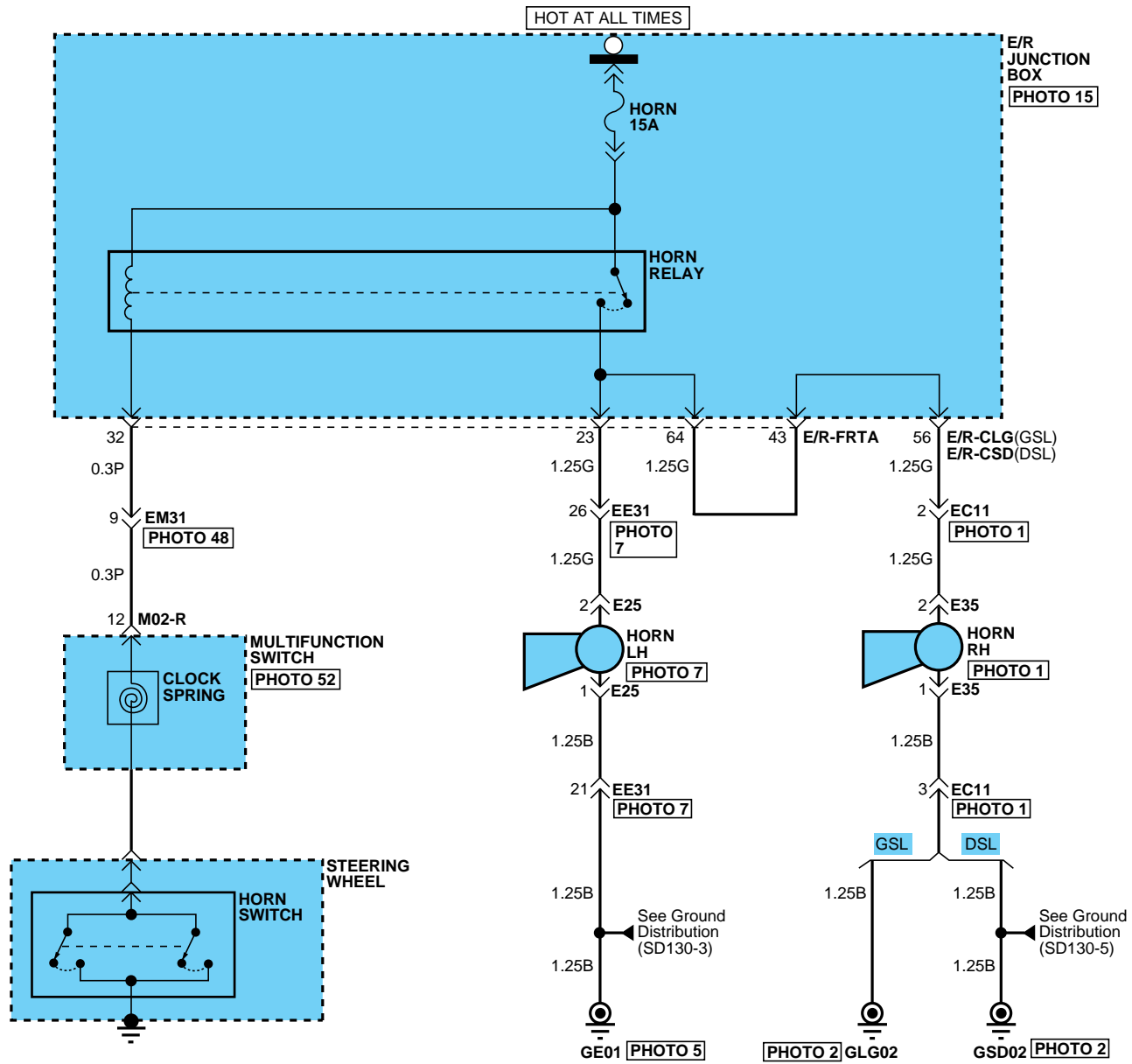

# HORNS

Horns (2)

SD968-2

**E25**

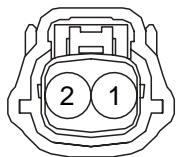

MLX\_HORN\_02F\_B\_FILT

**E35**

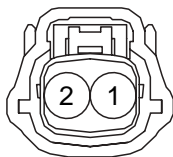

MLX\_HORN\_02F\_B\_FILT

**M02-R**

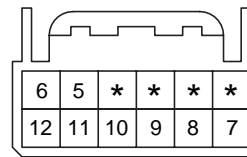

AMP\_025\_12F\_W

**BLANK**

A/V & Navigation (1)

SD969-1

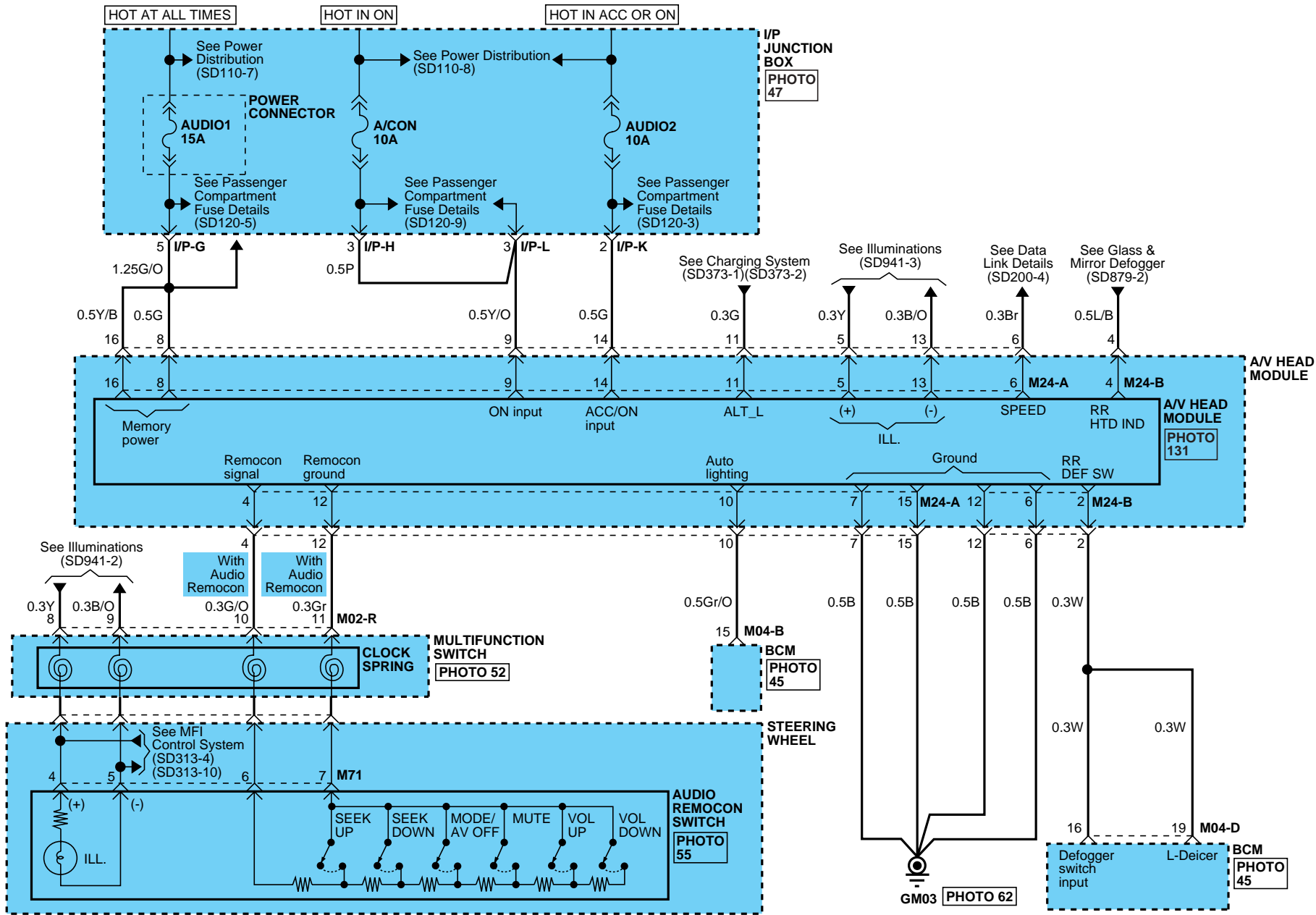

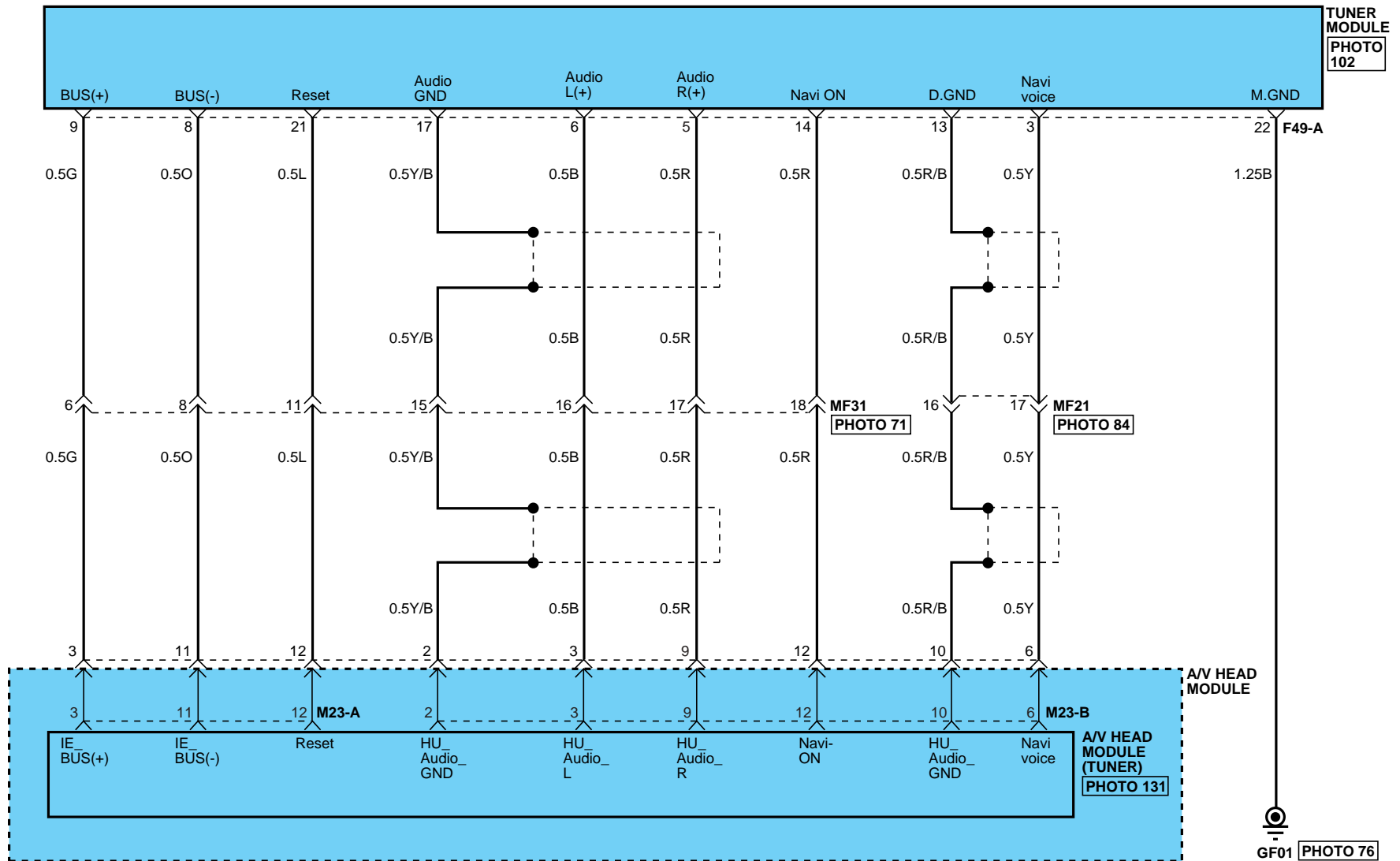

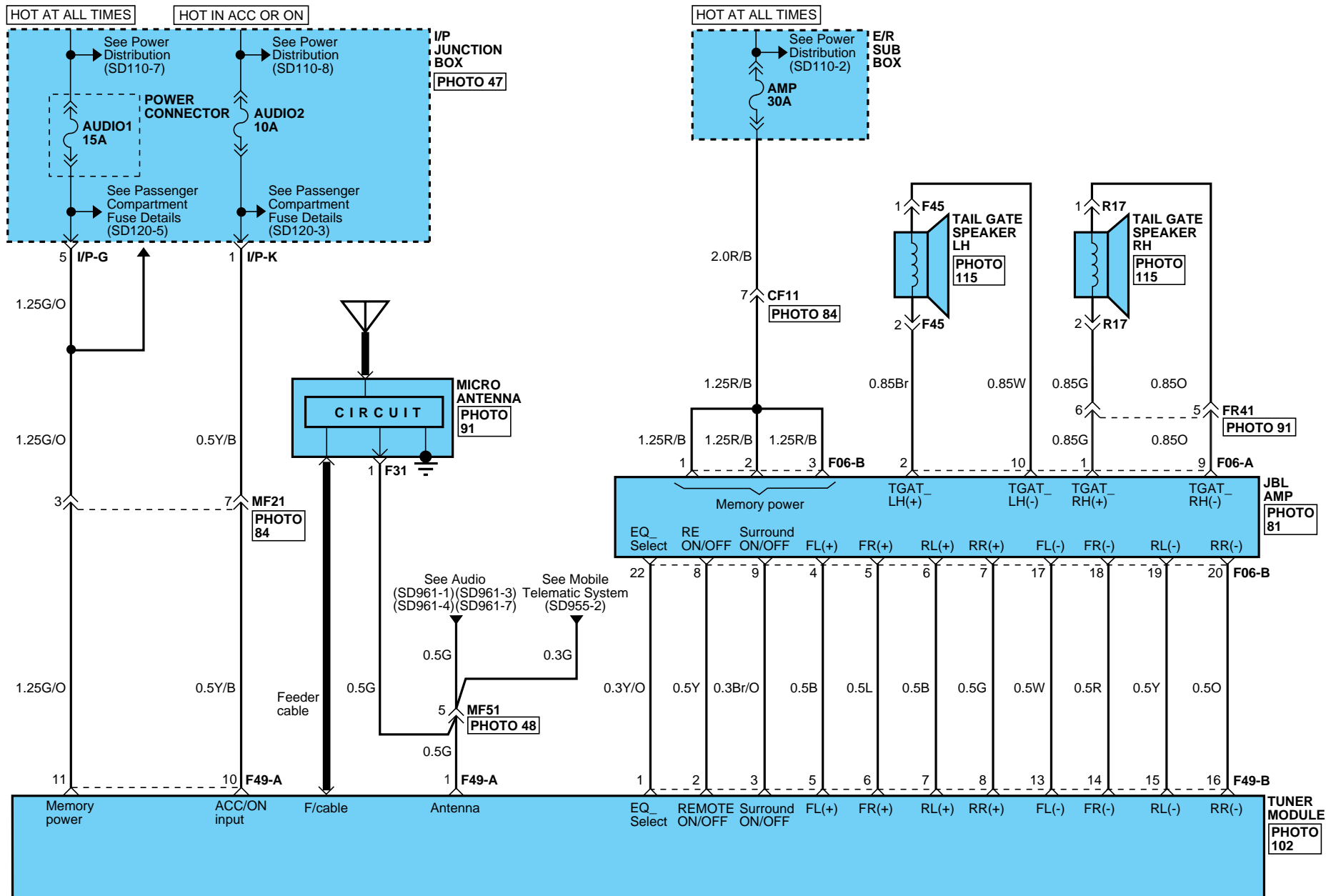

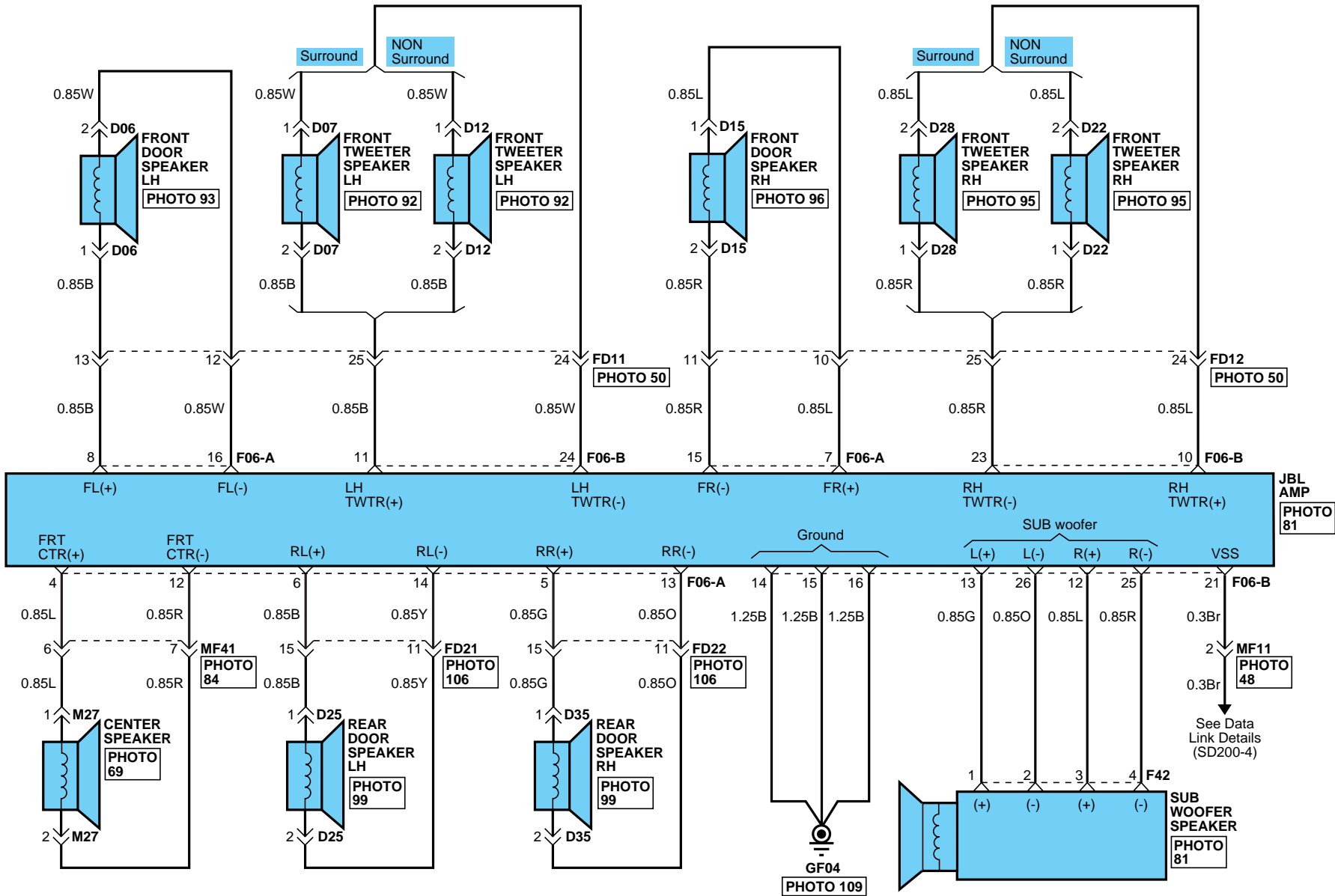



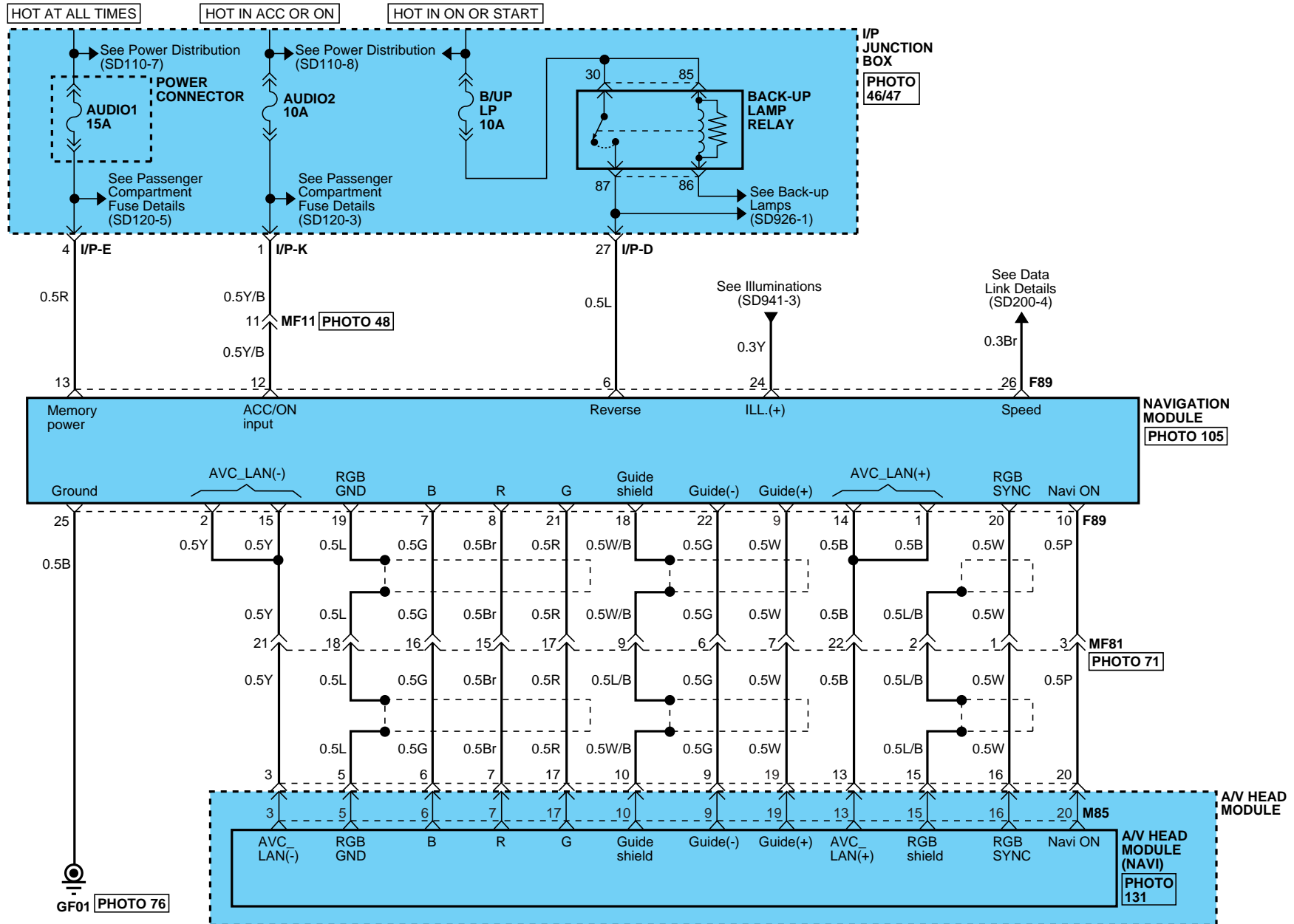

# A/V & NAVIGATION

## A/V & Navigation (6)

SD969-6

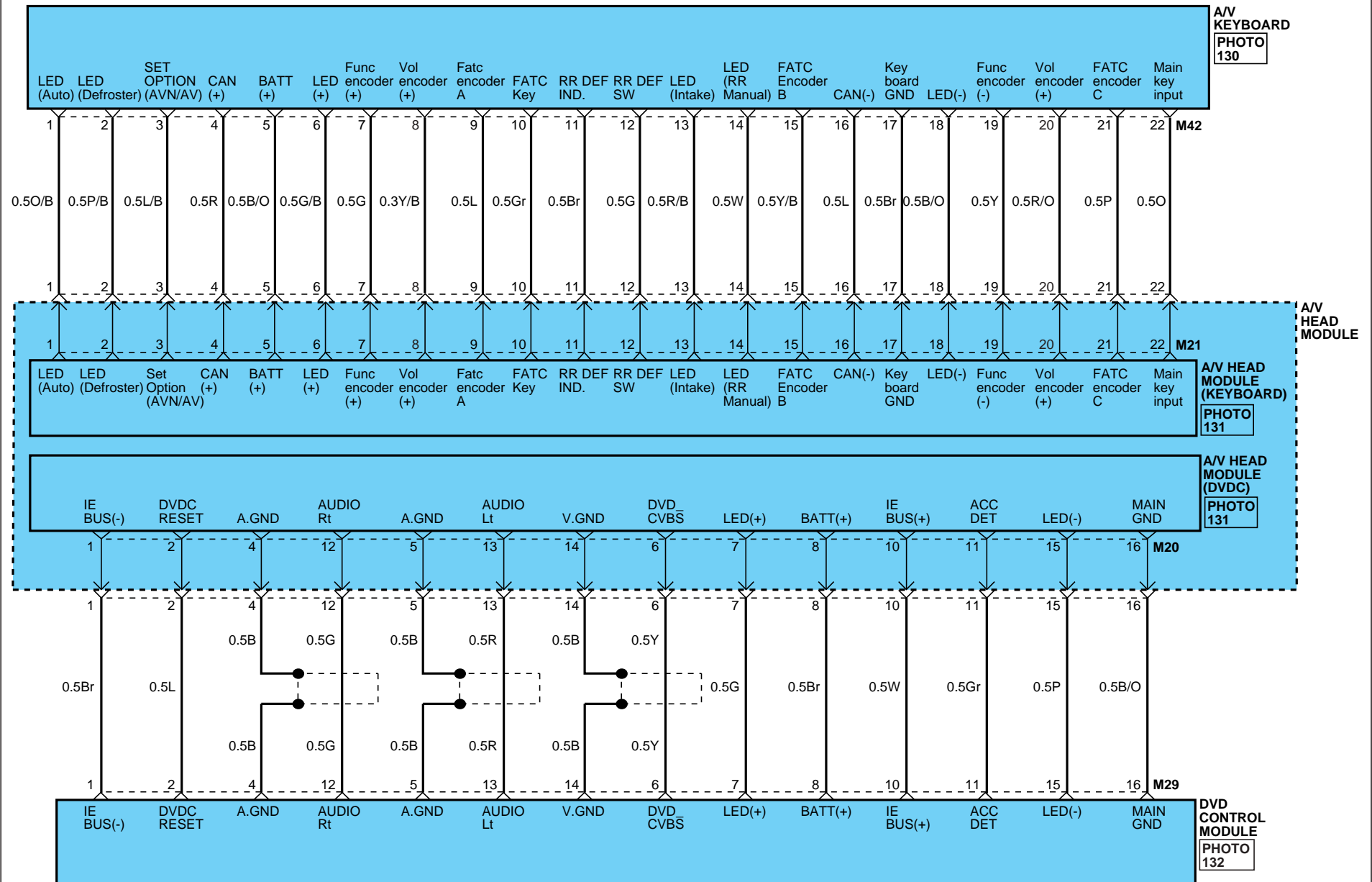

**A/V & NAVIGATION**

**A/V & Navigation (7)**

**SD969-7**

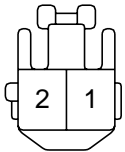
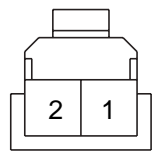
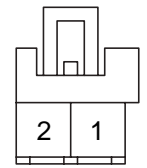
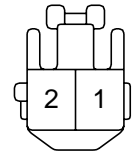
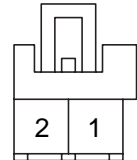
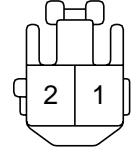
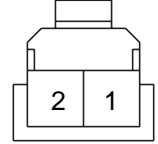
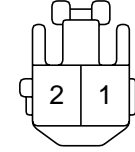
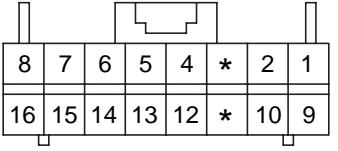
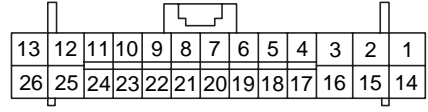
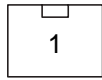
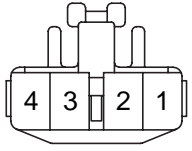
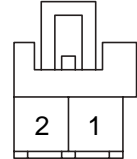
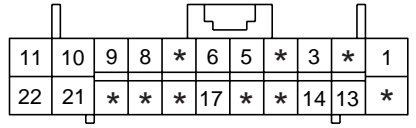
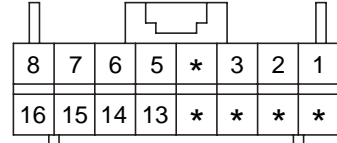
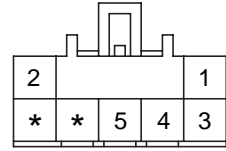
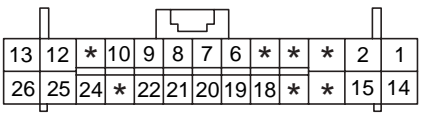
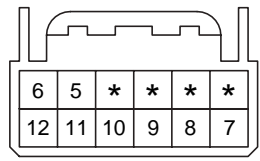
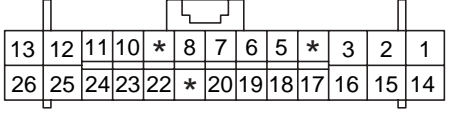
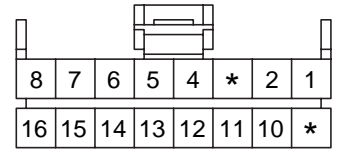
<p><b>D06</b></p>  <p>KET_090III_02F_W_L</p>	<p><b>D07</b></p>  <p>AMP_070_02F_W</p>	<p><b>D12</b></p>  <p>KUM_CDR_02F_W</p>	<p><b>D15</b></p>  <p>KET_090III_02F_W_L</p>
<p><b>D22</b></p>  <p>KUM_CDR_02F_W</p>	<p><b>D25</b></p>  <p>KET_090III_02F_W_L</p>	<p><b>D28</b></p>  <p>AMP_070_02F_W</p>	<p><b>D35</b></p>  <p>KET_090III_02F_W_L</p>
<p><b>F06-A</b></p>  <p>AMP_0407II_16F_GY</p>	<p><b>F06-B</b></p>  <p>AMP_0407MII_26F_GY</p>	<p><b>F31</b></p>  <p>AMP_PLM1_01F_B</p>	<p><b>F42</b></p>  <p>KET_090II_04F_W</p>
<p><b>F45</b></p>  <p>KUM_CDR_02F_W</p>	<p><b>F49-A</b></p>  <p>AMP_0407_22F_W_HD</p>	<p><b>F49-B</b></p>  <p>AMP_0407_16F_W_040</p>	<p><b>F74</b></p>  <p>KUM_CDR_07F_L</p>
<p><b>F89</b></p>  <p>AMP_0407_26F_W_HD</p>	<p><b>M02-R</b></p>  <p>AMP_025_12F_W</p>	<p><b>M04-B</b></p>  <p>AMP_0407_26F_Gr_HD</p>	<p><b>M20</b></p>  <p>AMP_040M1_16F_B</p>

# A/V & NAVIGATION

## A/V & Navigation (8)

SD969-8

<p style="text-align: center;"><b>M21</b></p> <table border="1" style="margin: auto;"> <tr><td>10</td><td>9</td><td>8</td><td>7</td><td>6</td><td></td><td>5</td><td>4</td><td>3</td><td>2</td><td>1</td></tr> <tr><td>22</td><td>21</td><td>20</td><td>19</td><td>18</td><td>17</td><td>16</td><td>15</td><td>14</td><td>13</td><td>12</td><td>11</td></tr> </table> <p style="text-align: right; font-size: small;">JAE_040_22F_G</p>	10	9	8	7	6		5	4	3	2	1	22	21	20	19	18	17	16	15	14	13	12	11	<p style="text-align: center;"><b>M23-A</b></p> <table border="1" style="margin: auto;"> <tr><td>*</td><td>*</td><td>*</td><td>*</td><td>*</td><td>3</td><td>*</td><td>*</td></tr> <tr><td>*</td><td>*</td><td>*</td><td>*</td><td>12</td><td>11</td><td>*</td><td>*</td></tr> </table> <p style="text-align: right; font-size: small;">MLX_040_16F_Gr</p>	*	*	*	*	*	3	*	*	*	*	*	*	12	11	*	*	<p style="text-align: center;"><b>M23-B</b></p> <table border="1" style="margin: auto;"> <tr><td>6</td><td>*</td><td>*</td><td>3</td><td>2</td><td>*</td></tr> <tr><td>12</td><td>11</td><td>10</td><td>9</td><td>*</td><td>*</td></tr> </table> <p style="text-align: right; font-size: small;">MLX_040_12F_Gr</p>	6	*	*	3	2	*	12	11	10	9	*	*	<p style="text-align: center;"><b>M24-A</b></p> <table border="1" style="margin: auto;"> <tr><td>8</td><td>7</td><td>6</td><td>5</td><td>4</td><td>*</td><td>*</td><td>*</td></tr> <tr><td>16</td><td>15</td><td>14</td><td>13</td><td>12</td><td>11</td><td>10</td><td>9</td></tr> </table> <p style="text-align: right; font-size: small;">AMP_DLL_16F_B</p>	8	7	6	5	4	*	*	*	16	15	14	13	12	11	10	9
10	9	8	7	6		5	4	3	2	1																																																												
22	21	20	19	18	17	16	15	14	13	12	11																																																											
*	*	*	*	*	3	*	*																																																															
*	*	*	*	12	11	*	*																																																															
6	*	*	3	2	*																																																																	
12	11	10	9	*	*																																																																	
8	7	6	5	4	*	*	*																																																															
16	15	14	13	12	11	10	9																																																															
<p style="text-align: center;"><b>M24-B</b></p> <table border="1" style="margin: auto;"> <tr><td>6</td><td>*</td><td>4</td><td>*</td><td>2</td><td>*</td></tr> <tr><td>12</td><td>*</td><td>*</td><td>*</td><td>*</td><td>*</td></tr> </table> <p style="text-align: right; font-size: small;">AMP_DLL_12F_B</p>	6	*	4	*	2	*	12	*	*	*	*	*	<p style="text-align: center;"><b>M27</b></p> <table border="1" style="margin: auto;"> <tr><td>2</td><td>1</td></tr> </table> <p style="text-align: right; font-size: small;">AMP_PLM2_02F_B</p>	2	1	<p style="text-align: center;"><b>M29</b></p> <table border="1" style="margin: auto;"> <tr><td>8</td><td>7</td><td>6</td><td>5</td><td>4</td><td>*</td><td>2</td><td>1</td></tr> <tr><td>16</td><td>15</td><td>14</td><td>13</td><td>12</td><td>11</td><td>10</td><td>*</td></tr> </table> <p style="text-align: right; font-size: small;">AMP_040M1_16F_B</p>	8	7	6	5	4	*	2	1	16	15	14	13	12	11	10	*	<p style="text-align: center;"><b>M42</b></p> <table border="1" style="margin: auto;"> <tr><td>10</td><td>9</td><td>8</td><td>7</td><td>6</td><td></td><td>5</td><td>4</td><td>3</td><td>2</td><td>1</td></tr> <tr><td>22</td><td>21</td><td>20</td><td>19</td><td>18</td><td>17</td><td>16</td><td>15</td><td>14</td><td>13</td><td>12</td><td>11</td></tr> </table> <p style="text-align: right; font-size: small;">JAE_040_22F_G</p>	10	9	8	7	6		5	4	3	2	1	22	21	20	19	18	17	16	15	14	13	12	11														
6	*	4	*	2	*																																																																	
12	*	*	*	*	*																																																																	
2	1																																																																					
8	7	6	5	4	*	2	1																																																															
16	15	14	13	12	11	10	*																																																															
10	9	8	7	6		5	4	3	2	1																																																												
22	21	20	19	18	17	16	15	14	13	12	11																																																											
<p style="text-align: center;"><b>M71</b></p> <table border="1" style="margin: auto;"> <tr><td>*</td><td>7</td><td>6</td><td>5</td><td>4</td><td>*</td><td>*</td><td>*</td></tr> </table> <p style="text-align: right; font-size: small;">AMP_1743386-2</p>	*	7	6	5	4	*	*	*	<p style="text-align: center;"><b>M85</b></p> <table border="1" style="margin: auto;"> <tr><td>10</td><td>9</td><td>*</td><td>7</td><td>6</td><td>5</td><td>*</td><td>3</td><td>*</td><td>*</td></tr> <tr><td>20</td><td>19</td><td>*</td><td>17</td><td>16</td><td>15</td><td>*</td><td>13</td><td>*</td><td>*</td></tr> </table> <p style="text-align: right; font-size: small;">MLX_040III_20F_Gr</p>	10	9	*	7	6	5	*	3	*	*	20	19	*	17	16	15	*	13	*	*	<p style="text-align: center;"><b>R17</b></p> <table border="1" style="margin: auto;"> <tr><td>2</td><td>1</td></tr> </table> <p style="text-align: right; font-size: small;">KUM_CDR_02F_W</p>	2	1	<p style="text-align: center; font-size: large;"><b>BLANK</b></p>																																					
*	7	6	5	4	*	*	*																																																															
10	9	*	7	6	5	*	3	*	*																																																													
20	19	*	17	16	15	*	13	*	*																																																													
2	1																																																																					



# FRONT BLOWER & A/C CONTROL SYSTEM

## Front Blower & A/C Control System (Auto) (2)

SD971-2

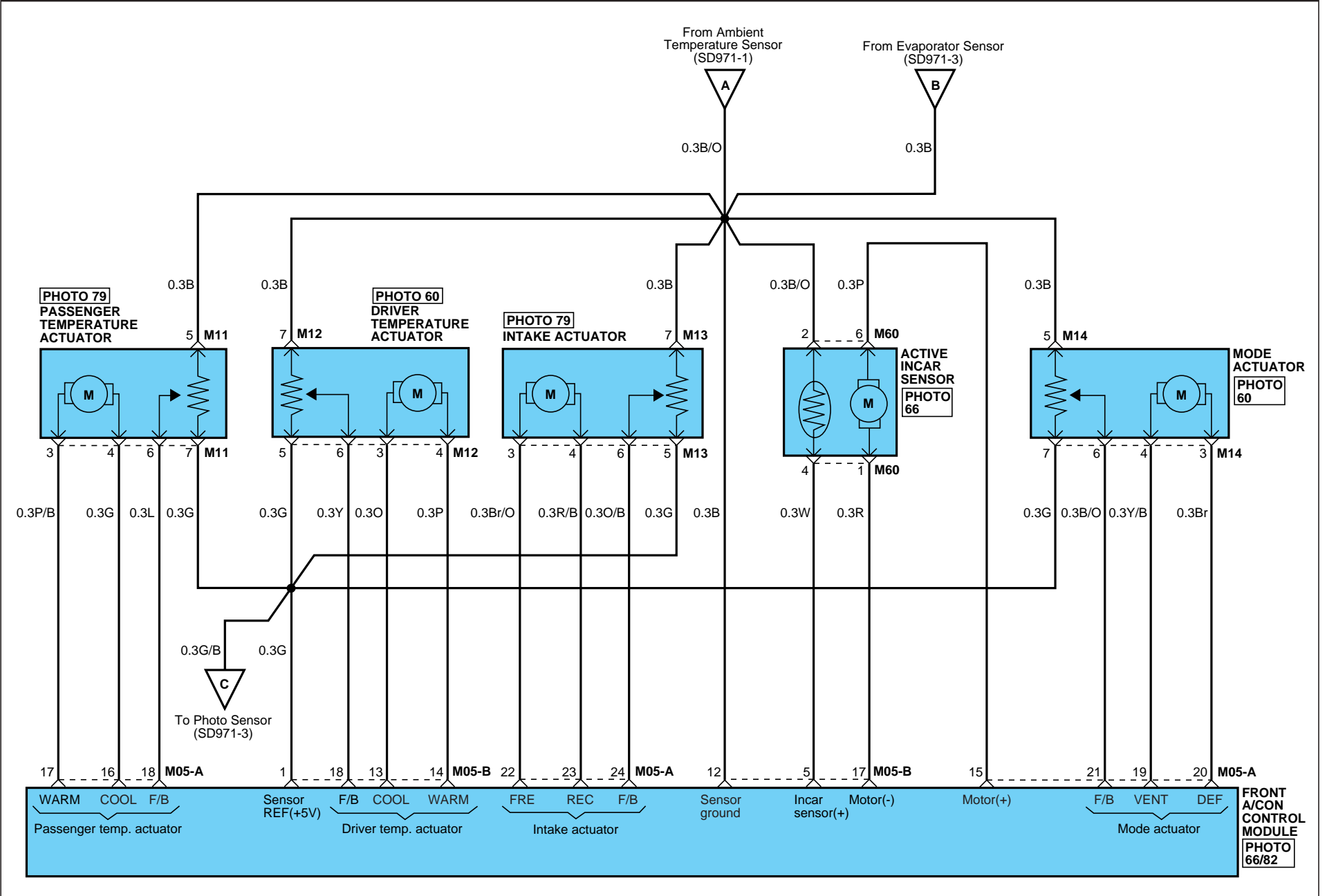

# FRONT BLOWER & A/C CONTROL SYSTEM

## Front Blower & A/C Control System (Auto) (3)

SD971-3

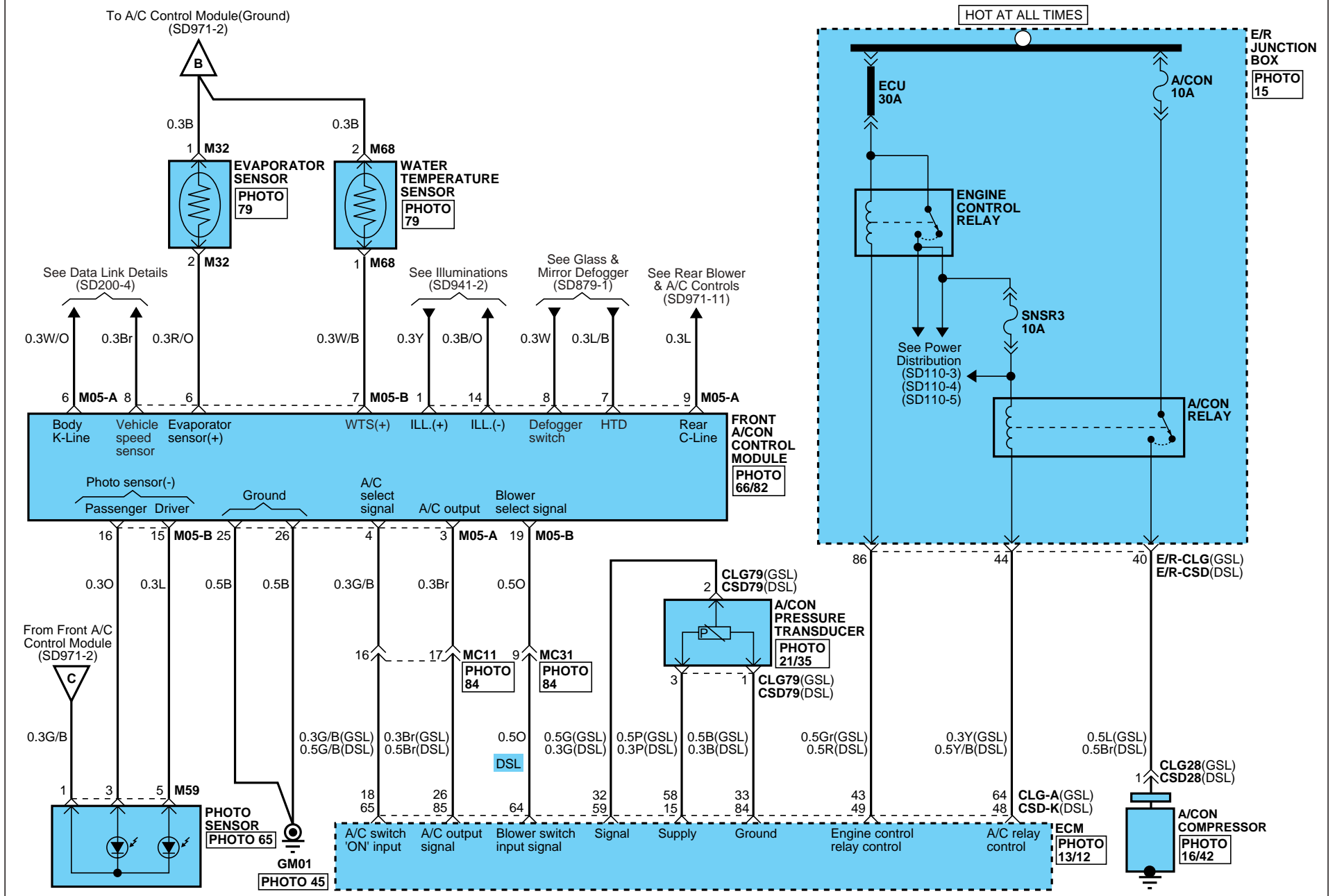





# FRONT BLOWER & A/C CONTROL SYSTEM

## Front Blower & A/C Control System (Auto) (5)

SD971-5

C01

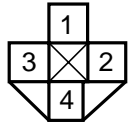

CR04F063

C02

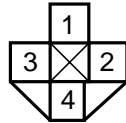

CR04F063

C03

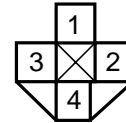

CR04F063

CLG28



KUM\_NMWP\_01F\_B

CLG-A

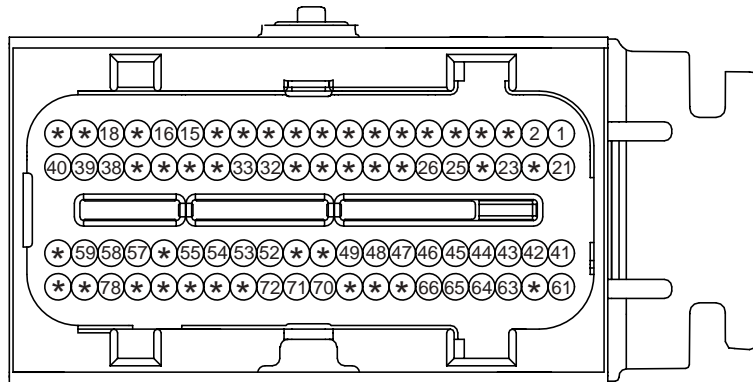

PKD\_ECU\_80F\_GR\_3

CSD-K

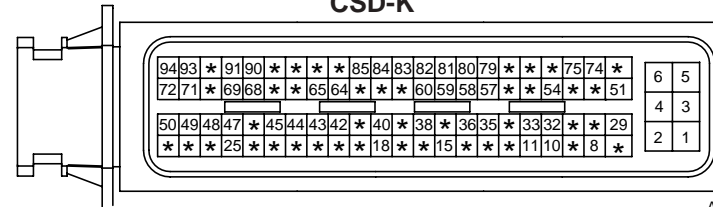

AMP\_ECU\_94F\_B

CSD28

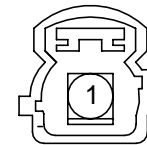

KUM\_NMWP\_01FA\_B

E21

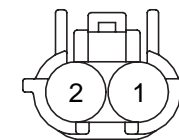

KET\_SWP\_02F\_B

E22

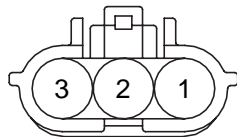

KET\_SWP\_03F\_B

M05-A

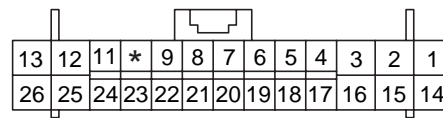

AMP\_0407\_26F\_W\_HD

M05-B

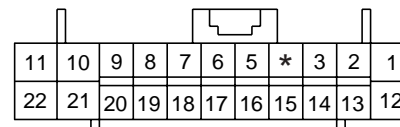

AMP\_0407\_22F\_W\_HD

M11

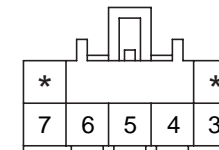

KUM\_CDR\_07F\_W

M12

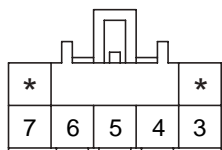

KUM\_CDR\_07F\_B

M13

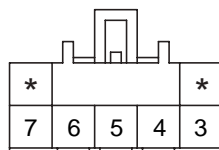

KUM\_CDR\_07F\_L

M14

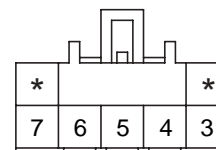

KUM\_CDR\_07F\_L

M25

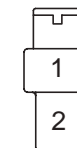

KET\_250\_02F\_W

# FRONT BLOWER & A/C CONTROL SYSTEM

## Front Blower & A/C Control System (Auto) (6)

SD971-6

**M32**

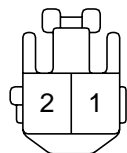

KET\_090II\_02F\_W\_L

**M35**

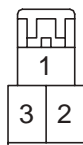

KUM\_DSD\_03F\_B

**M46**

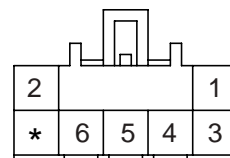

KUM\_CDR\_07F\_W

**M53**

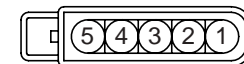

AMP\_375\_05F\_B

**M59**

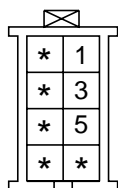

KET\_030\_08F\_GR

**M60**

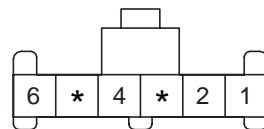

KET\_91A\_06F\_Gr

**M68**



KET\_090II\_02F\_W\_SPK

**BLANK**

Front Blower & A/C Control System (Manual) (1)

SD971-7

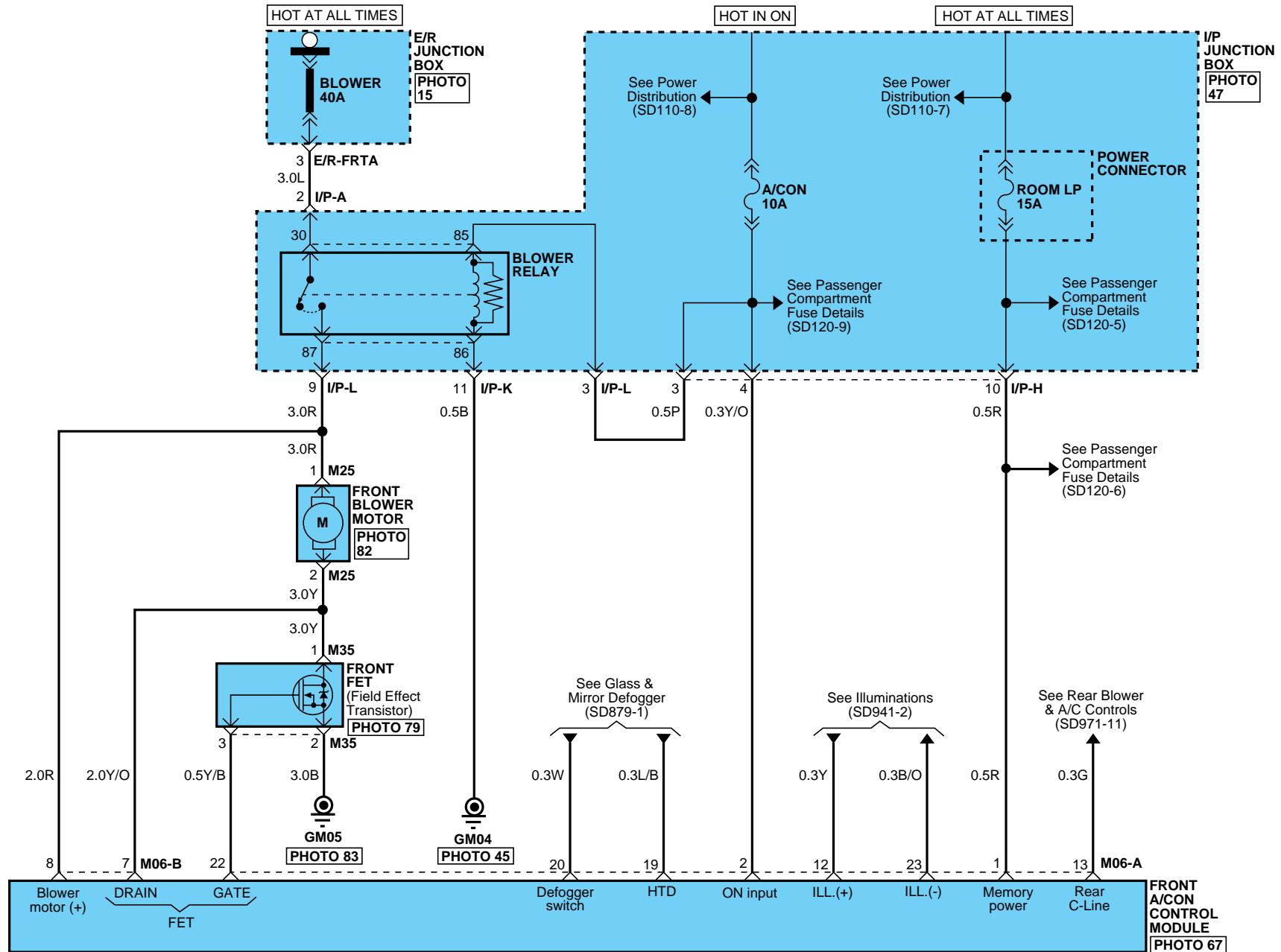



# FRONT BLOWER & A/C CONTROL SYSTEM

## Front Blower & A/C Control System (Manual) (3)

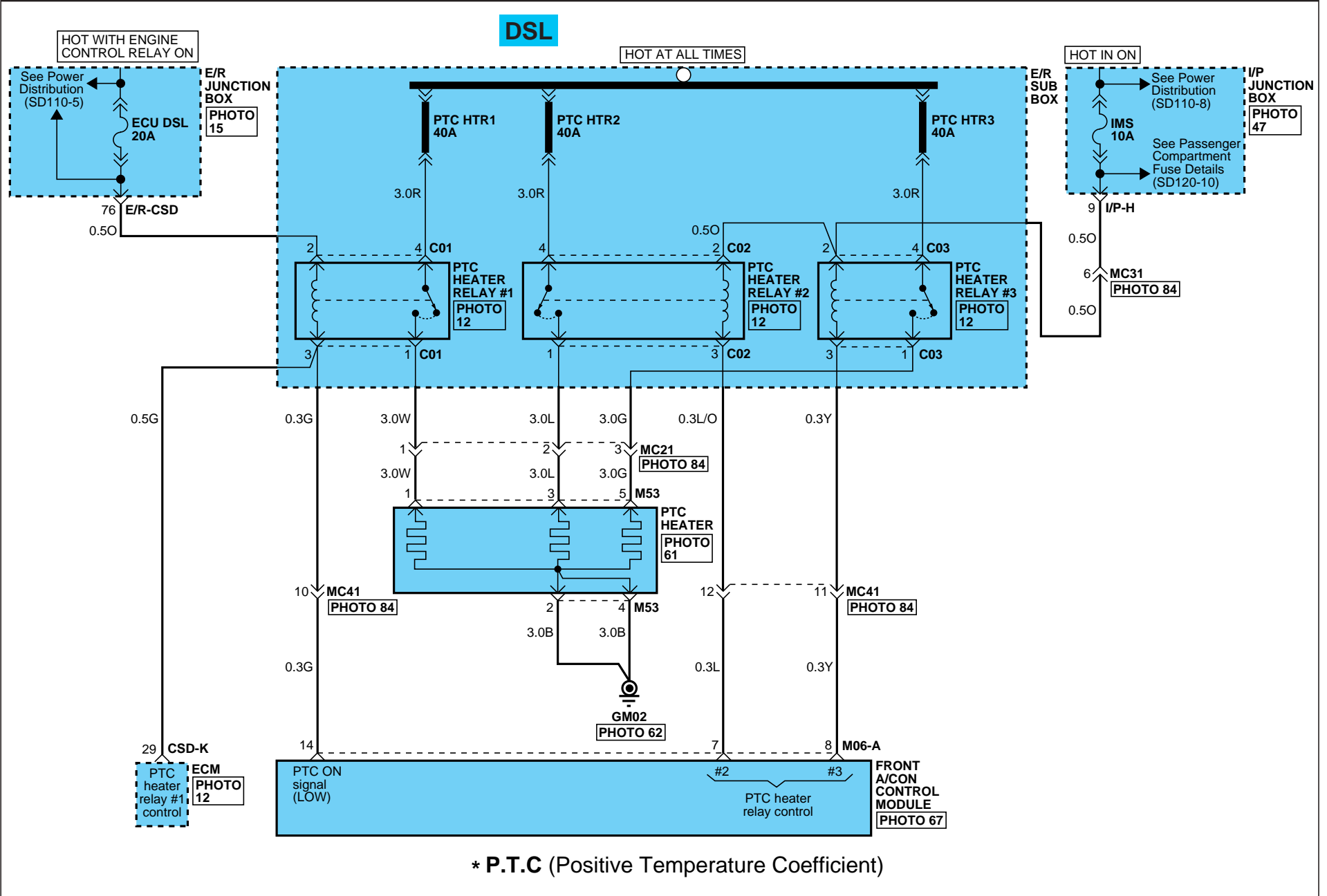

SD971-9



# FRONT BLOWER & A/C CONTROL SYSTEM

## Front Blower & A/C Control System (Manual) (4)

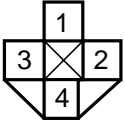
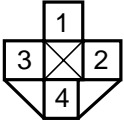
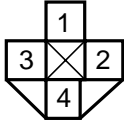
SD971-10

<p><b>C01</b></p>  <p style="text-align: right; font-size: small;">CR04F063</p>	<p><b>C02</b></p>  <p style="text-align: right; font-size: small;">CR04F063</p>	<p><b>C03</b></p>  <p style="text-align: right; font-size: small;">CR04F063</p>	<p><b>CLG28</b></p>  <p style="text-align: right; font-size: small;">KUM_NMWP_01F_B</p>
--	--	--	--

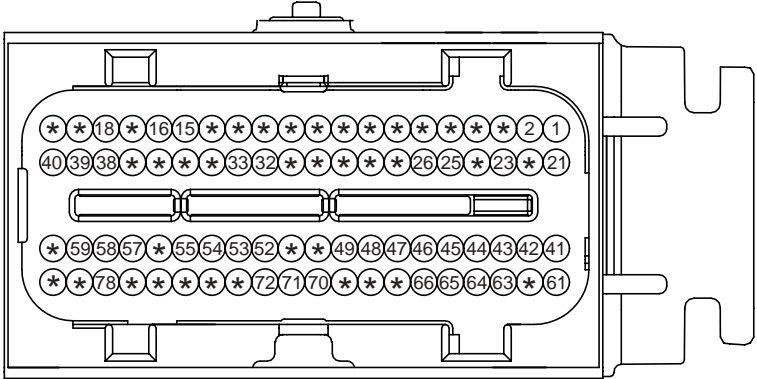
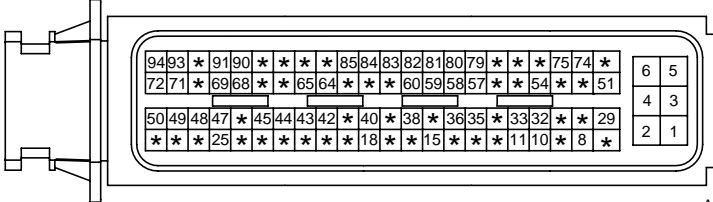
<p><b>CLG-A</b></p>  <p style="text-align: right; font-size: small;">PKD_ECU_80F_GR_3</p>	<p><b>CSD-K</b></p>  <p style="text-align: right; font-size: small;">AMP_ECU_94F_B</p>
---	---

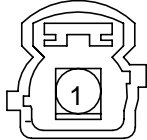
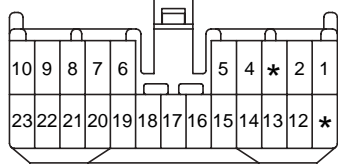
<p><b>CSD28</b></p>  <p style="text-align: right; font-size: small;">KUM_NMWP_01FA_B</p>	<p><b>M06-A</b></p>  <p style="text-align: right; font-size: small;">KET_050_23F_W</p>
---	---

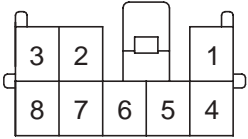
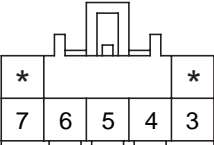
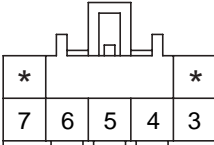
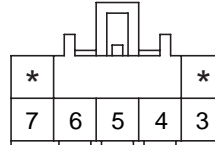
<p><b>M06-B</b></p>  <p style="text-align: right; font-size: small;">KET_070_08F_W</p>	<p><b>M11</b></p>  <p style="text-align: right; font-size: small;">KUM_CDR_07F_W</p>	<p><b>M13</b></p>  <p style="text-align: right; font-size: small;">KUM_CDR_07F_L</p>	<p><b>M14</b></p>  <p style="text-align: right; font-size: small;">KUM_CDR_07F_L</p>
---	---	---	---

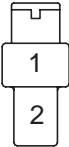
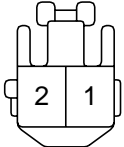
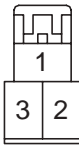
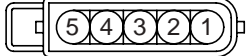
<p><b>M25</b></p>  <p style="text-align: right; font-size: small;">KET_250_02F_W</p>	<p><b>M32</b></p>  <p style="text-align: right; font-size: small;">KET_090II_02F_W_L</p>	<p><b>M35</b></p>  <p style="text-align: right; font-size: small;">KUM_DSD_03F_B</p>	<p><b>M53</b></p>  <p style="text-align: right; font-size: small;">AMP_375_05F_B</p>
---	---	---	---

# REAR BLOWER & A/C CONTROLS

EB56D854

## Rear Blower & A/C Controls (1)

SD971-11

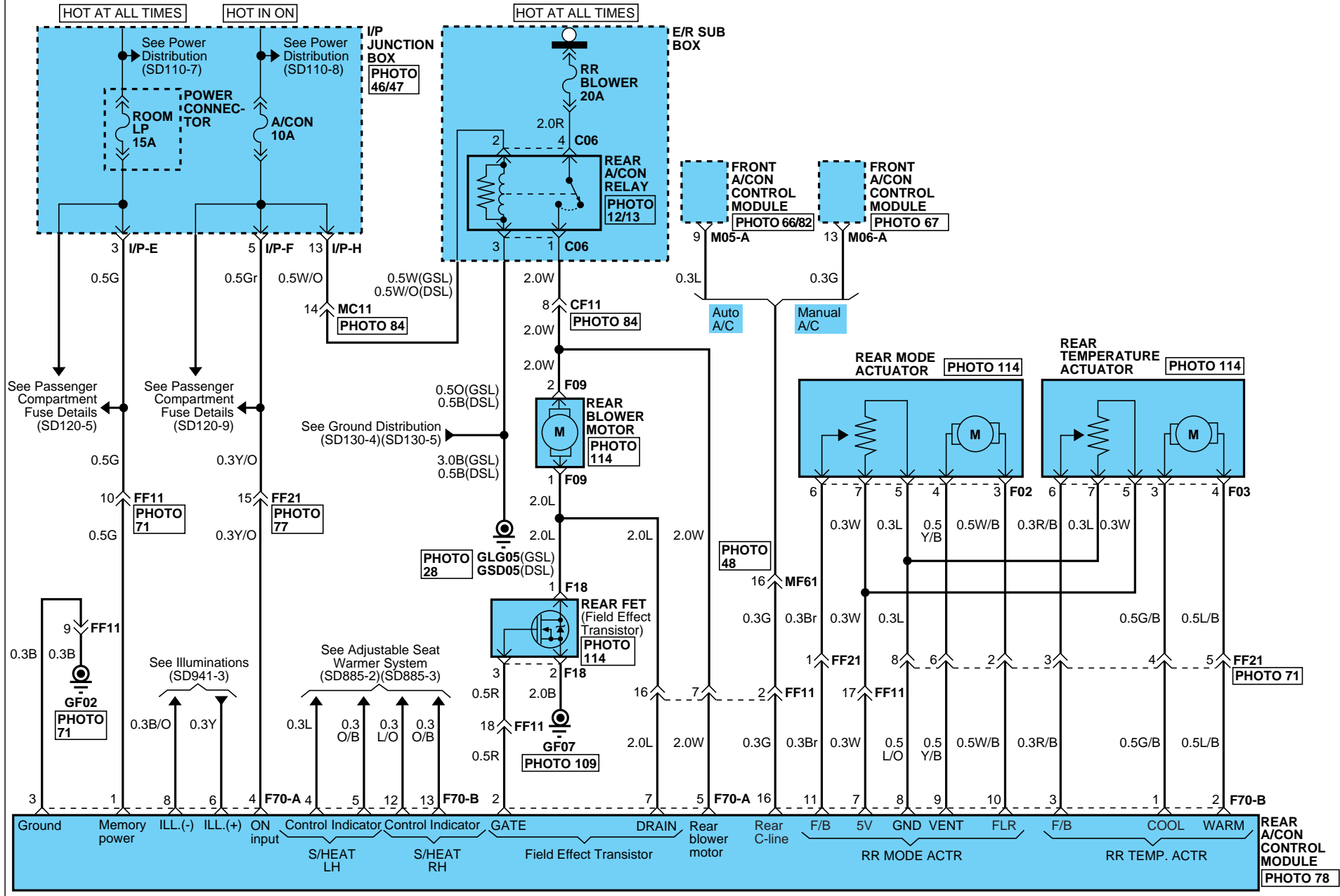

# REAR BLOWER & A/C CONTROLS

## Rear Blower & A/C Controls (2)

SD971-12

**C06**

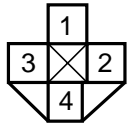

CR04F063

**F02**

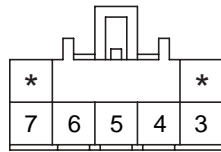

KUM\_CDR\_07F\_W

**F03**

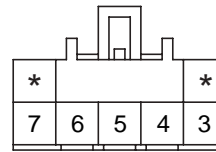

KUM\_CDR\_07F\_W

**F09**



KET\_250\_02F\_W

**F18**

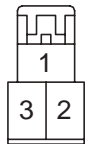

KUM\_DSD\_03F\_B

**F70-A**

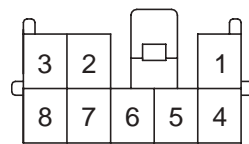

KET\_070\_08F\_W

**F70-B**

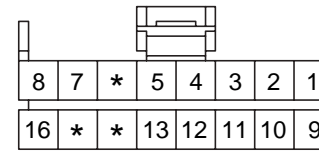

AMP\_040M1\_16F\_B

**M05-A**

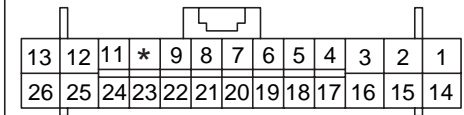

AMP\_0407\_26F\_W\_HD

**M06-A**

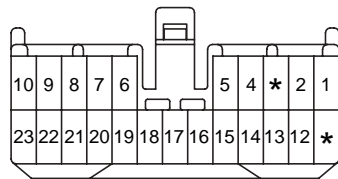

KET\_050\_23F\_W

**BLANK**

**BLANK**

**BLANK**



Front Wiper & Washer (1)

SD981-1

W/O RAIN SENSOR

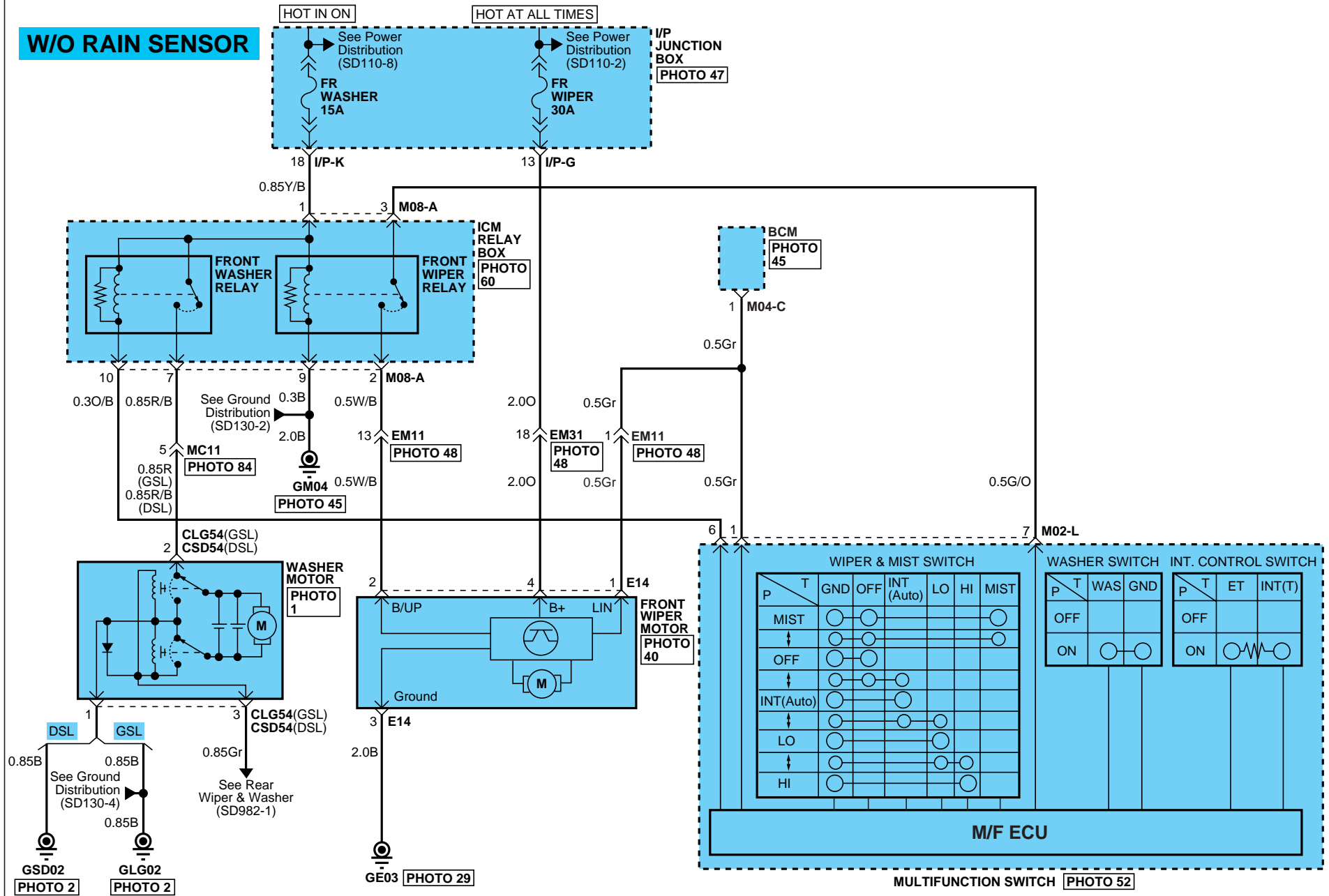



# FRONT WIPER & WASHER

## Front Wiper & Washer (3)

SD981-3

**CLG54**



KET\_090IWP\_03F\_Gr

**CSD54**



KET\_090IWP\_03F\_Gr

**E14**

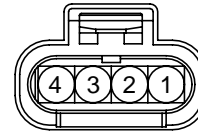

HIRSCHMANN\_SLK\_04F\_W

**M02-L**

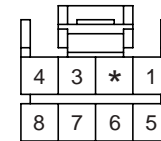

AMP\_040M1\_08F\_B

**M04-C**

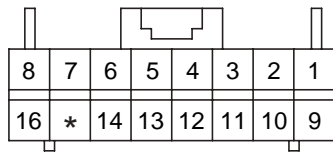

AMP\_0407\_16F\_W\_040

**M08-A**

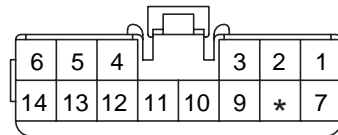

KET\_090I\_14F\_W

**R24**

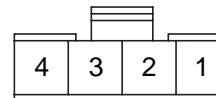

MLX\_FIT\_04F\_B

**BLANK**

**FRONT WIPER & WASHER**



**Front Wiper & Washer (4)**

**SD981-4**

**MEMO**

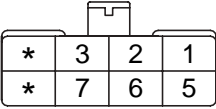
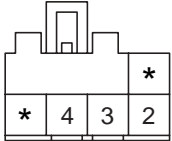
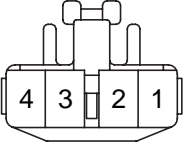

# REAR WIPER & WASHER

Rear Wiper & Washer (2)			SD982-2
<p><b>CLG54</b></p>  <p>KET_090IWP_03F_Gr</p>	<p><b>CSD54</b></p>  <p>KET_090IWP_03F_Gr</p>	<p><b>F37</b></p>  <p>KET_250_08F_B</p>	<p><b>M02-W</b></p>  <p>KUM_CDR_05F_W</p>
<p><b>R09</b></p>  <p>KET_090II_04F_W</p>	<p><b>BLANK</b></p>	<p><b>BLANK</b></p>	<p><b>BLANK</b></p>

Component Locations (1)

CL-1

PHOTO.1

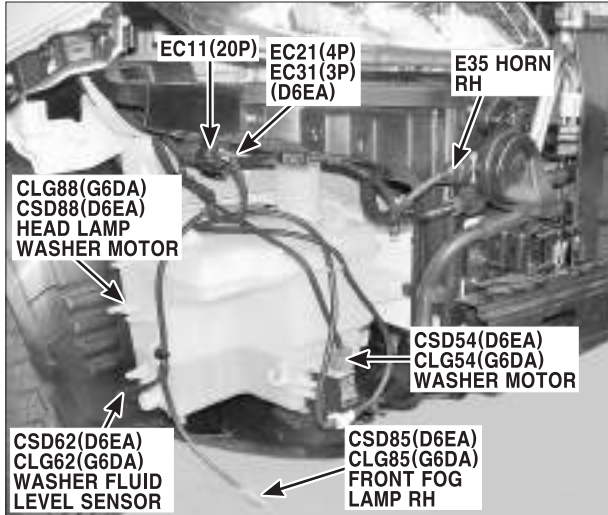

PHOTO.2

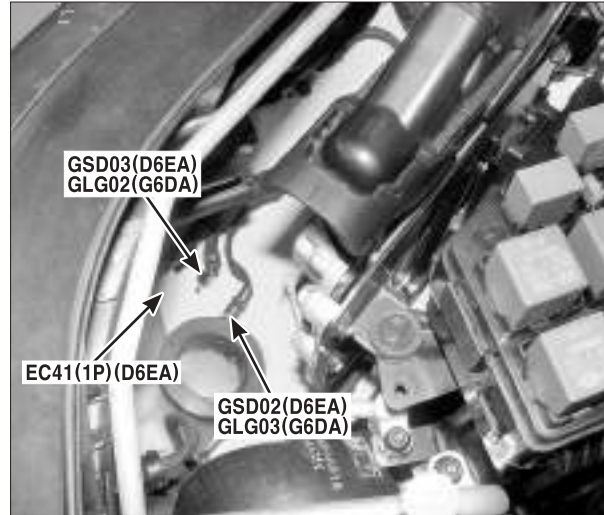

PHOTO.3

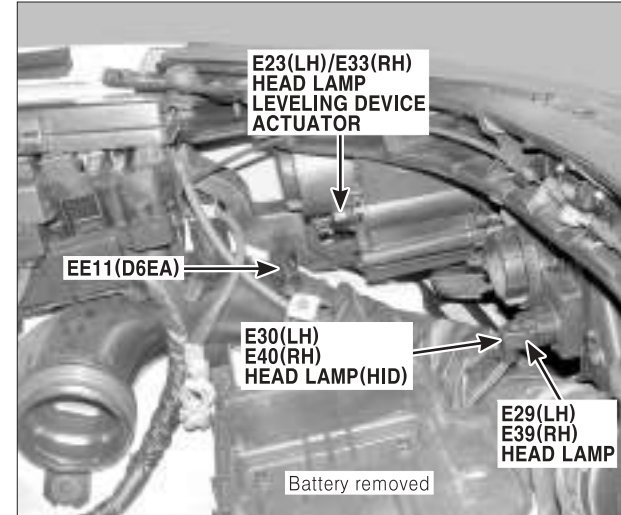

PHOTO.4

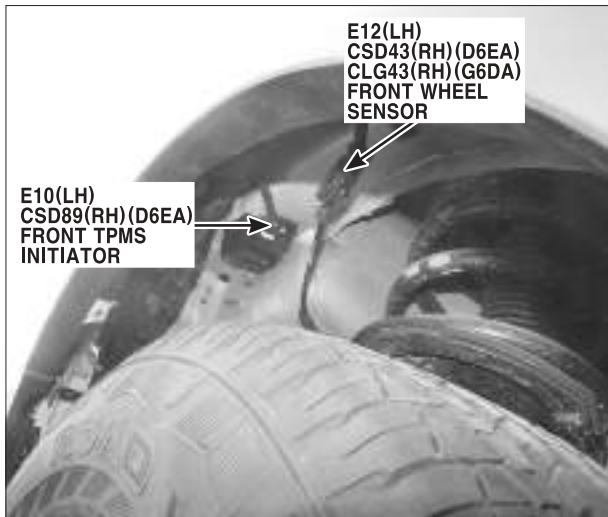

PHOTO.5

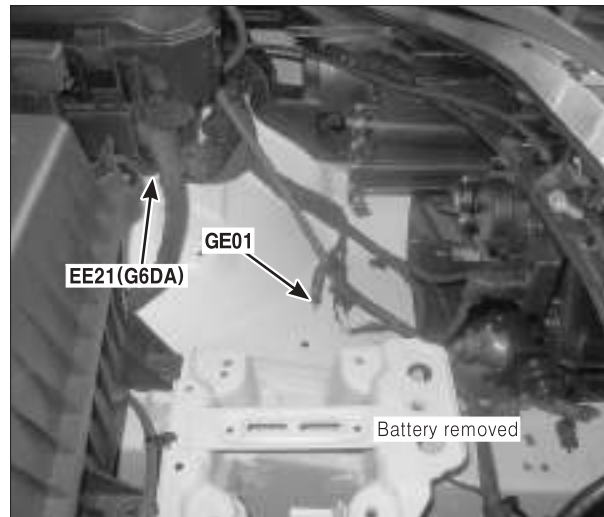
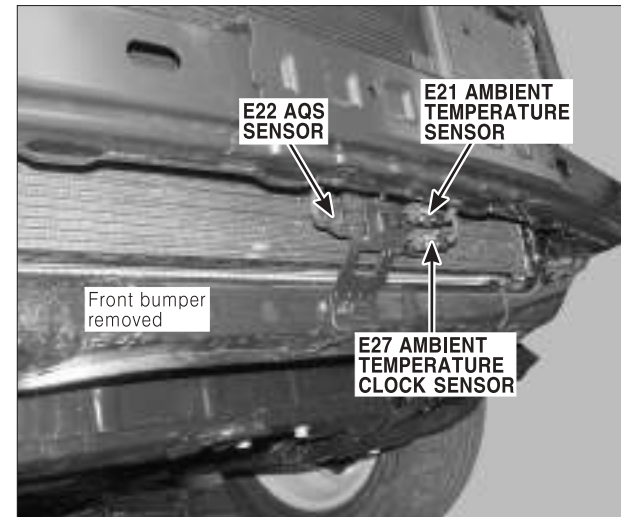

PHOTO.6





# COMPONENT LOCATIONS

## Component Locations (2)

CL-2

PHOTO.7

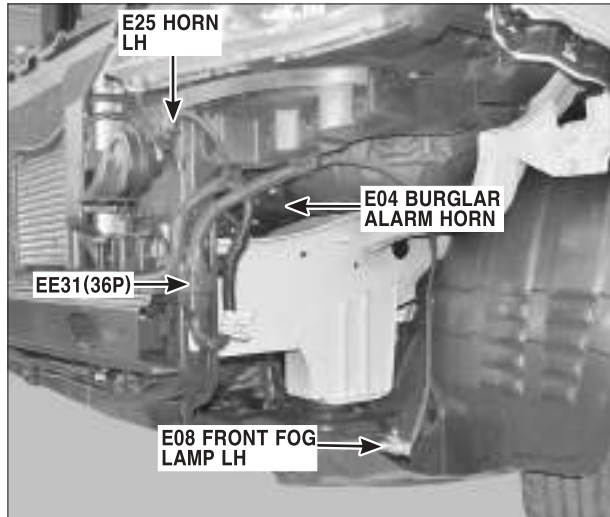

PHOTO.8



PHOTO.9

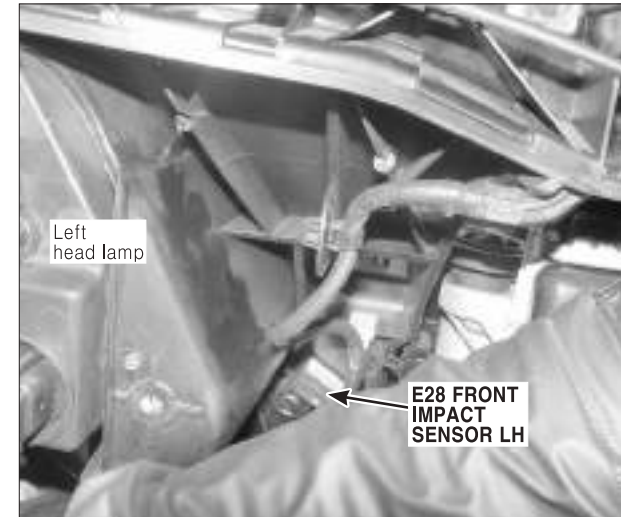

PHOTO.10

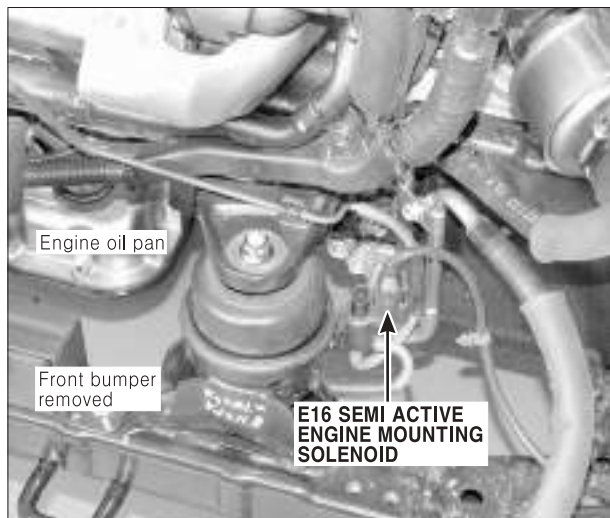

PHOTO.11

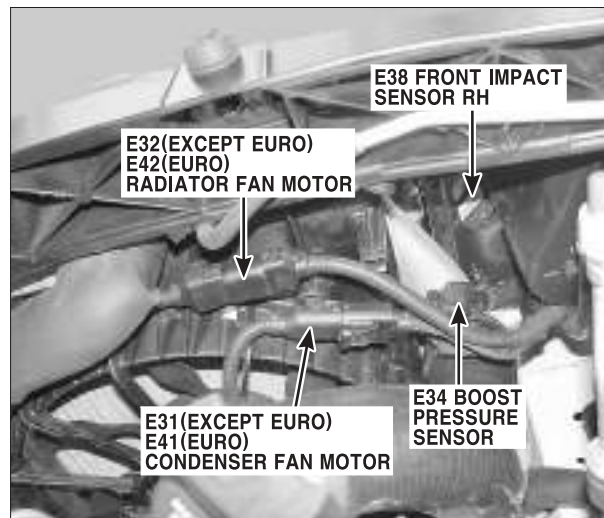
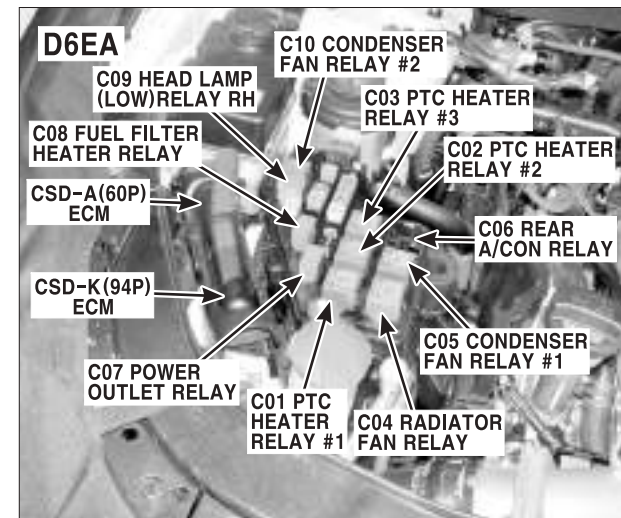

PHOTO.12





# COMPONENT LOCATIONS

## Component Locations (3)

CL-3

PHOTO.13

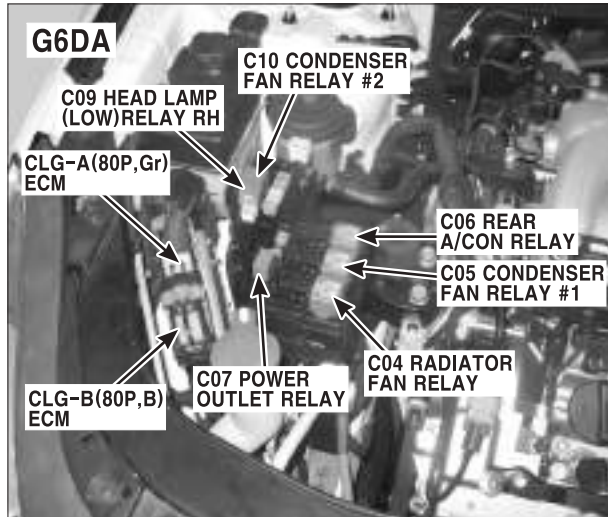

PHOTO.14

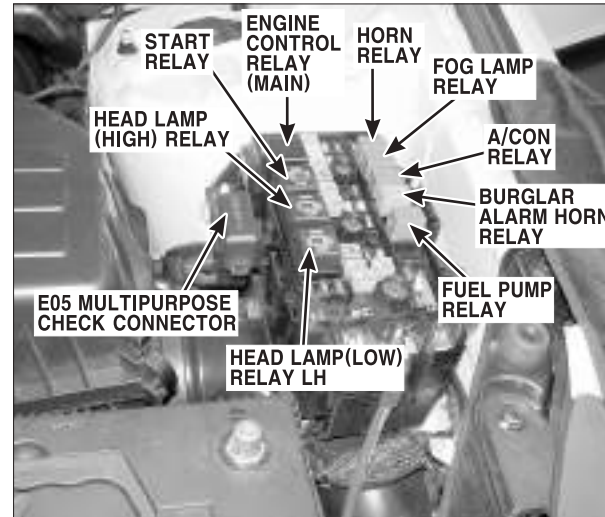

PHOTO.15

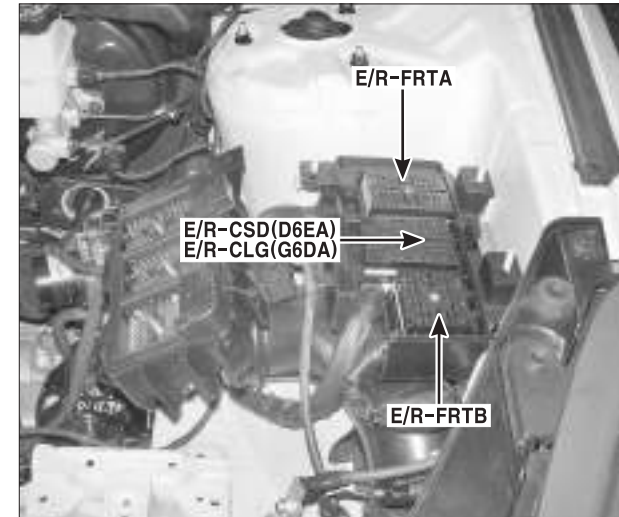

PHOTO.16

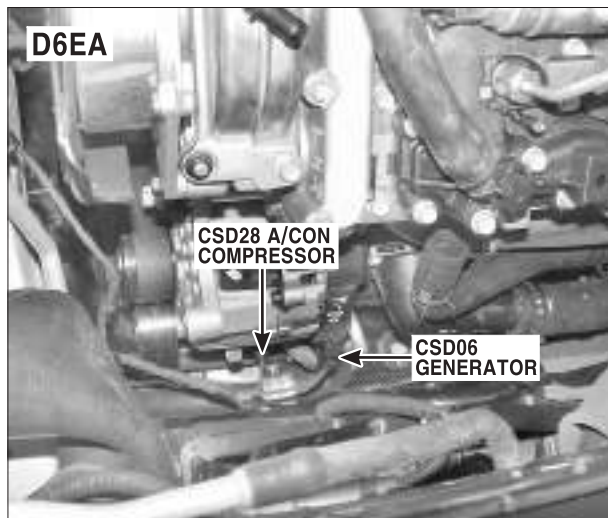

PHOTO.17

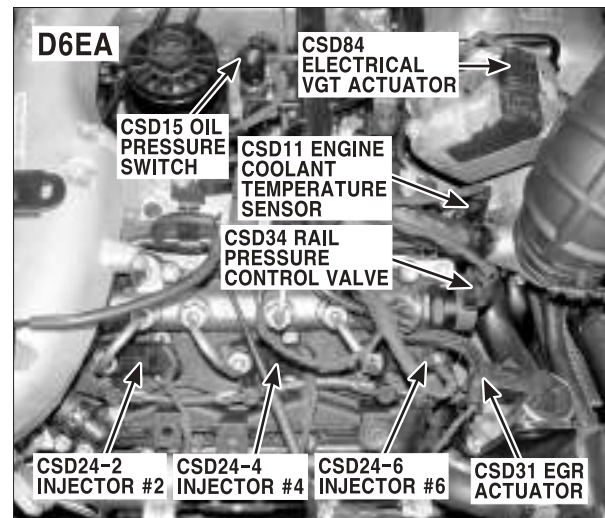
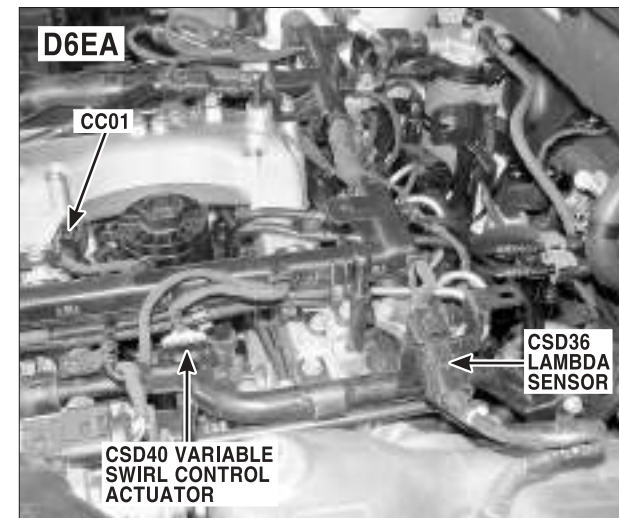

PHOTO.18



# COMPONENT LOCATIONS

## Component Locations (4)

CL-4

PHOTO.19

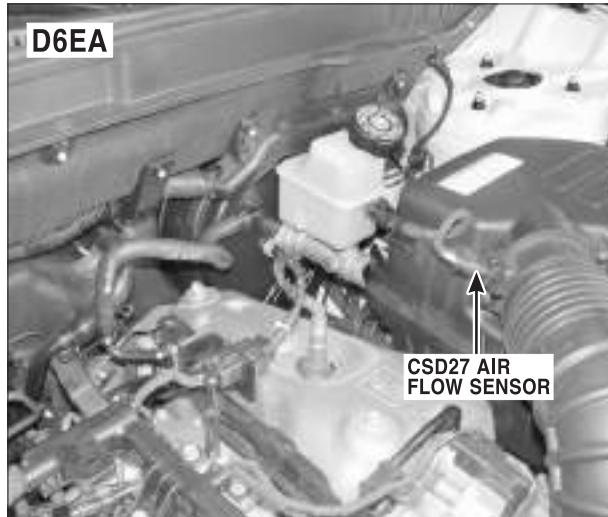

PHOTO.20

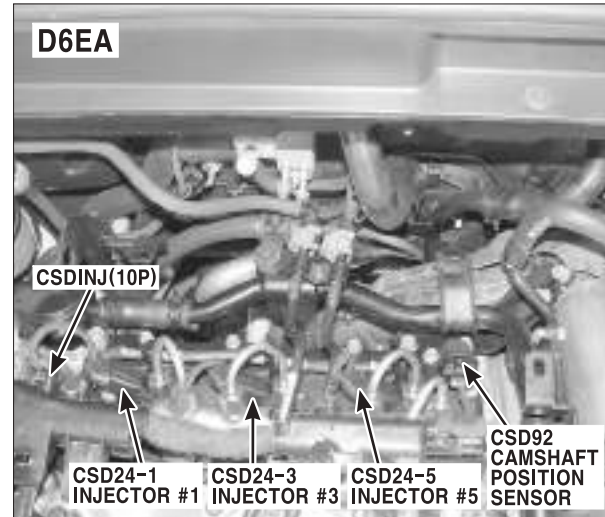

PHOTO.21

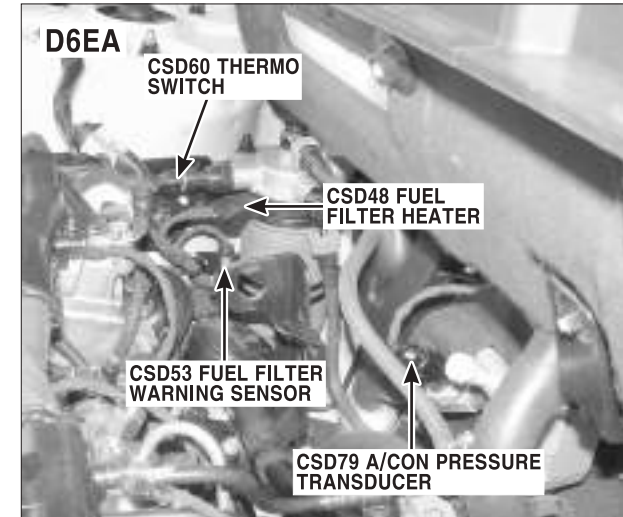

PHOTO.22

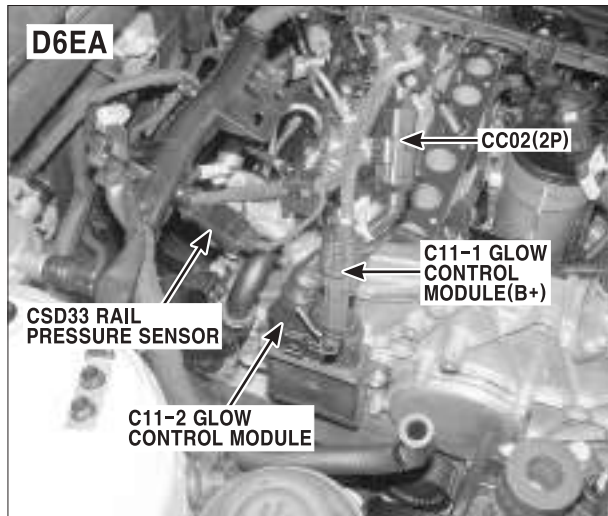

PHOTO.23

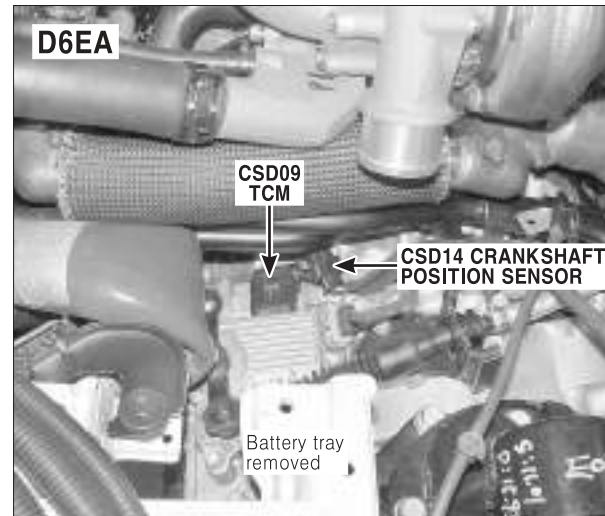
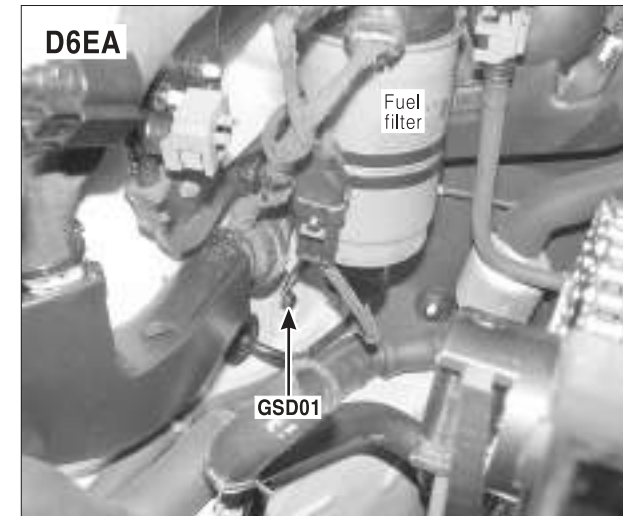

PHOTO.24





# COMPONENT LOCATIONS

## Component Locations (5)

CL-5

PHOTO.25

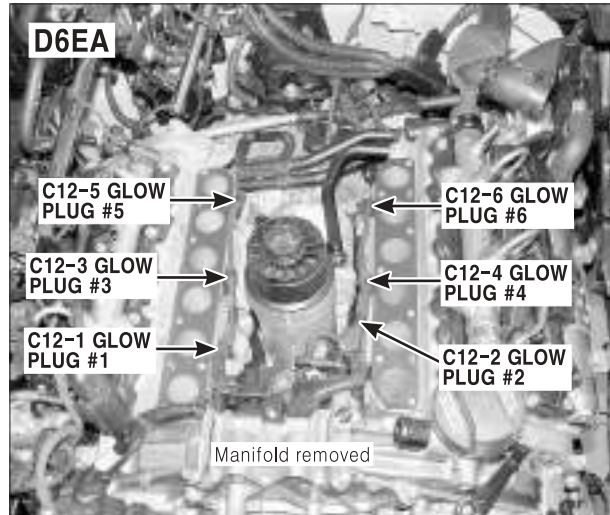

PHOTO.26

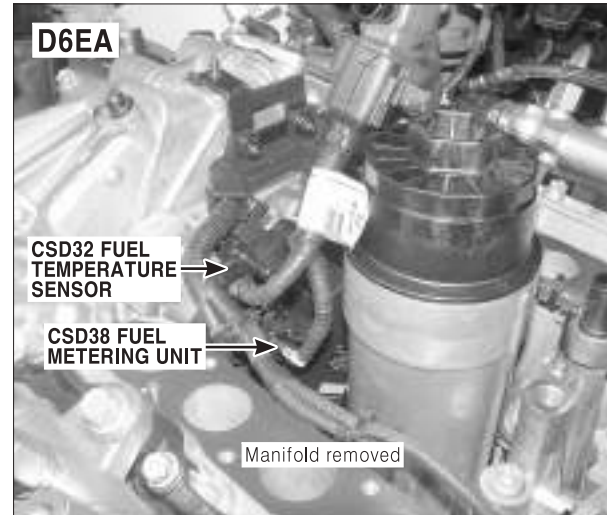

PHOTO.27

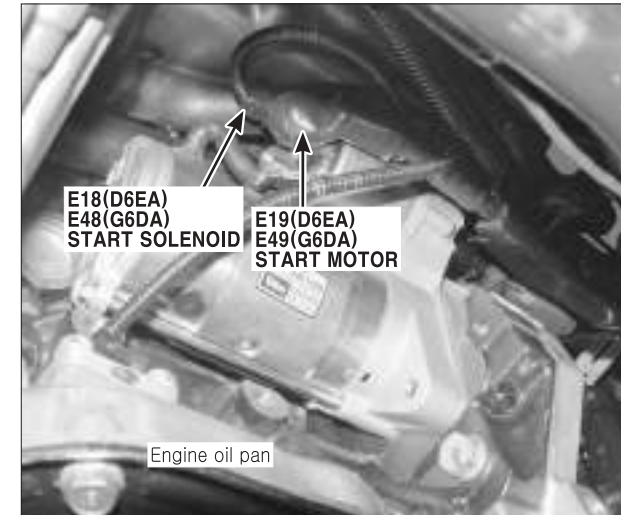

PHOTO.28

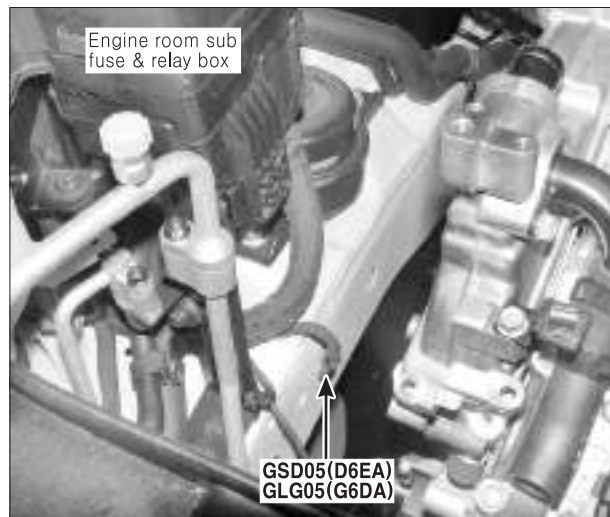

PHOTO.29

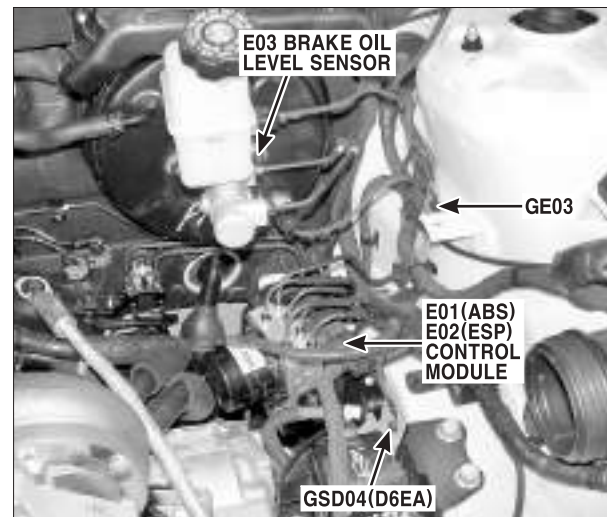
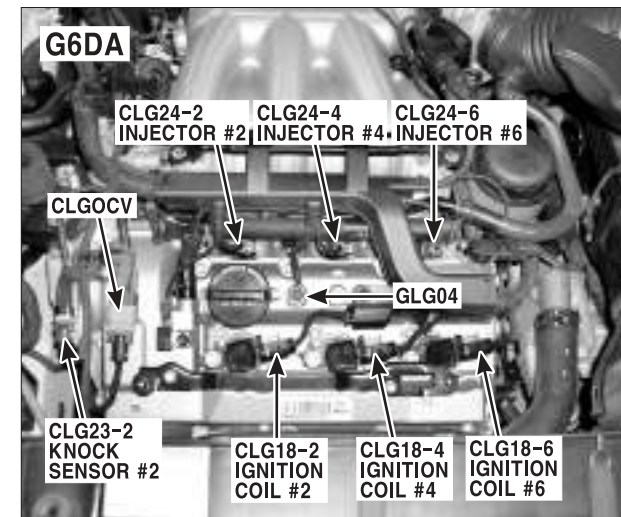

PHOTO.30



# COMPONENT LOCATIONS

## Component Locations (6)

CL-6

PHOTO.31

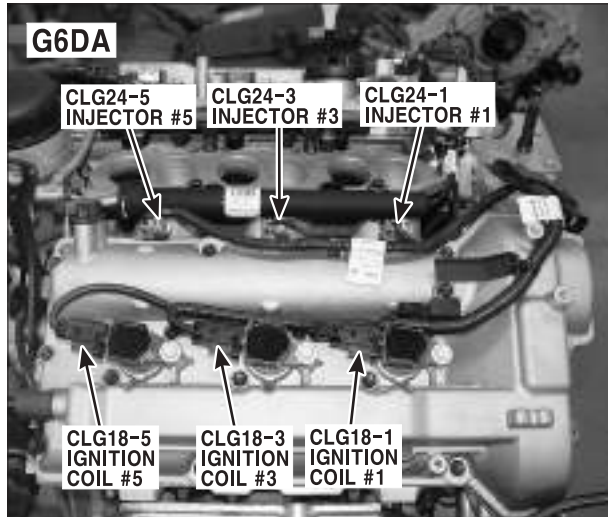

PHOTO.32

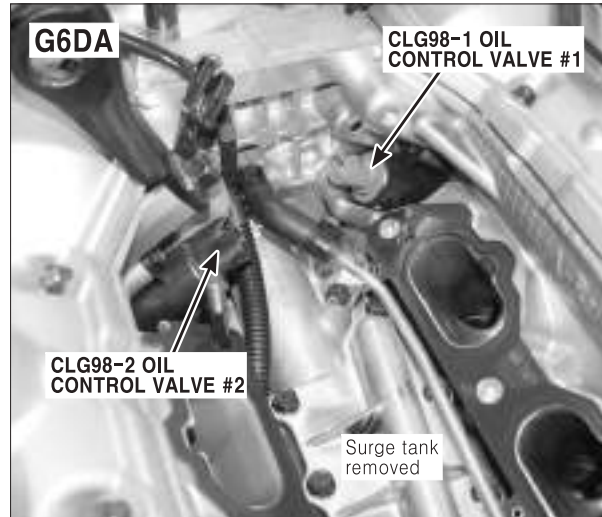

PHOTO.33

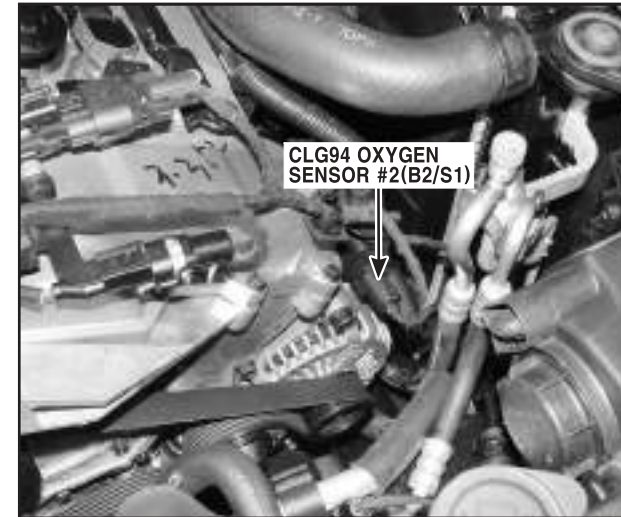

PHOTO.34

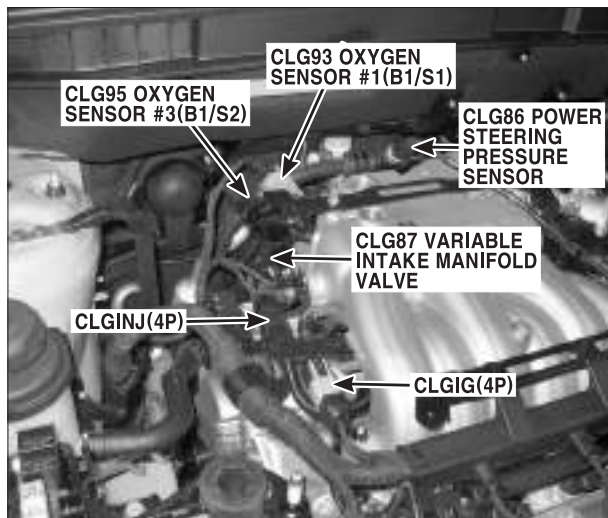

PHOTO.35

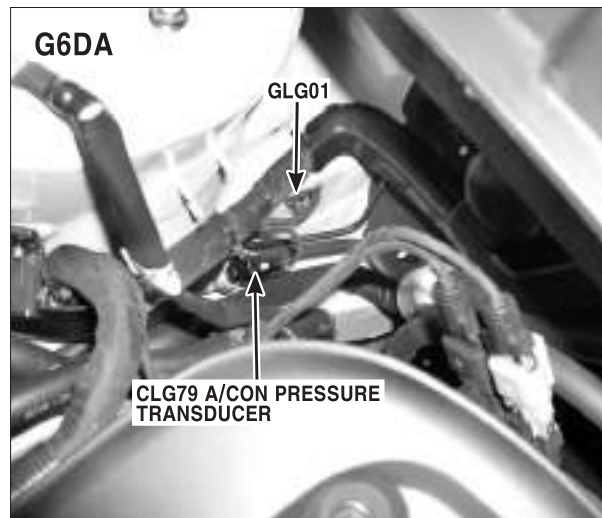
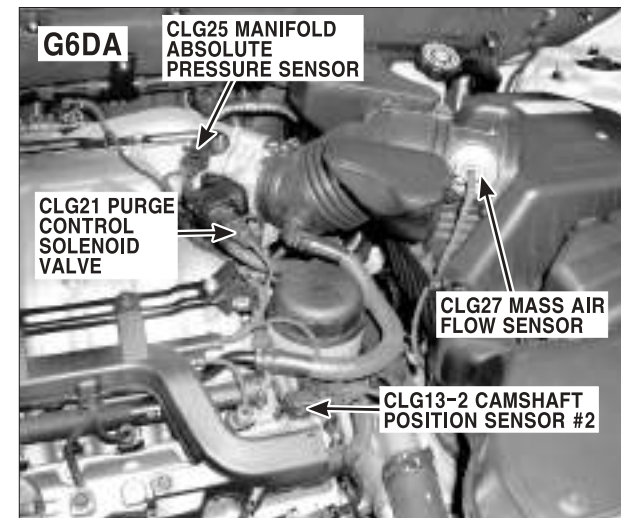

PHOTO.36





# COMPONENT LOCATIONS

## Component Locations (7)

CL-7

PHOTO.37

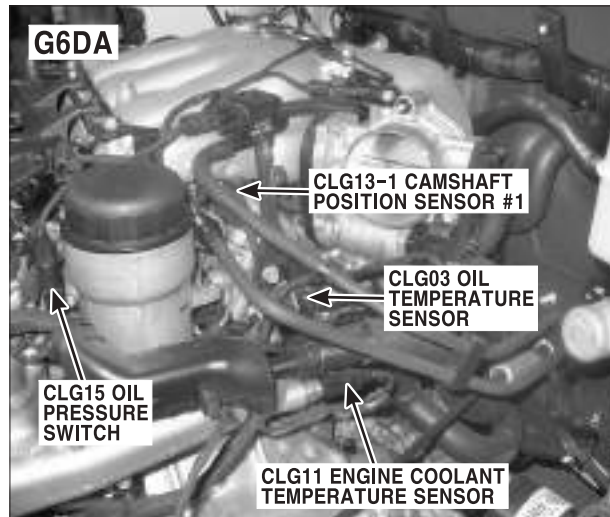

PHOTO.38

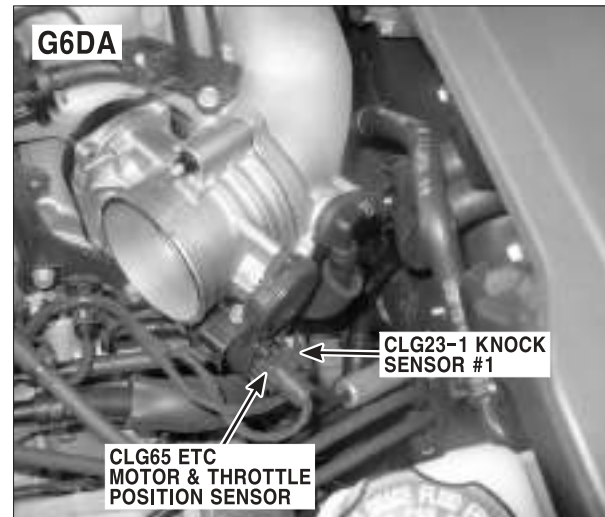

PHOTO.39

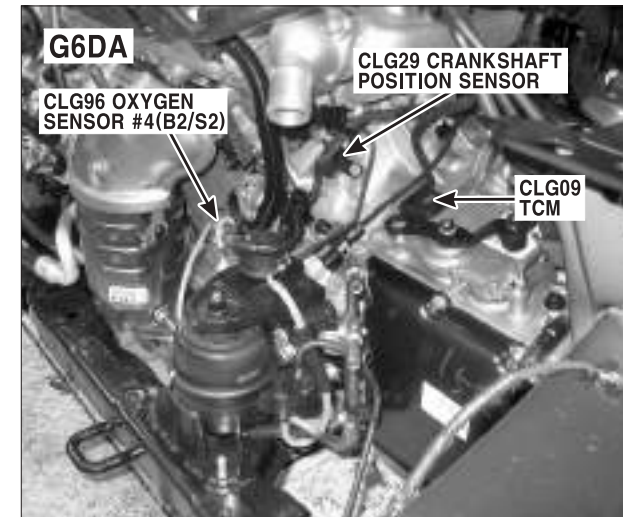

PHOTO.40

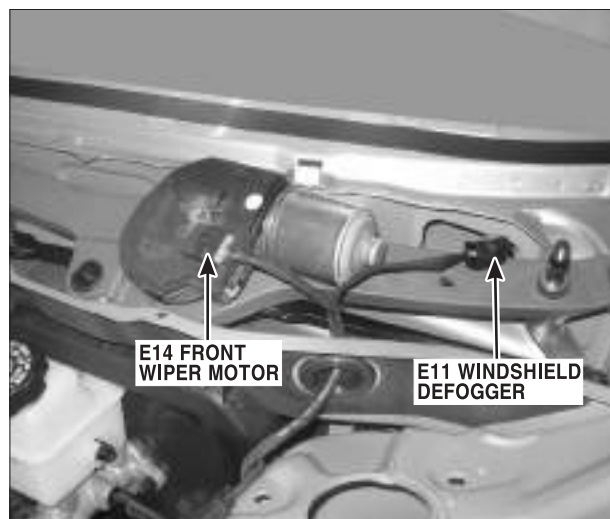

PHOTO.41

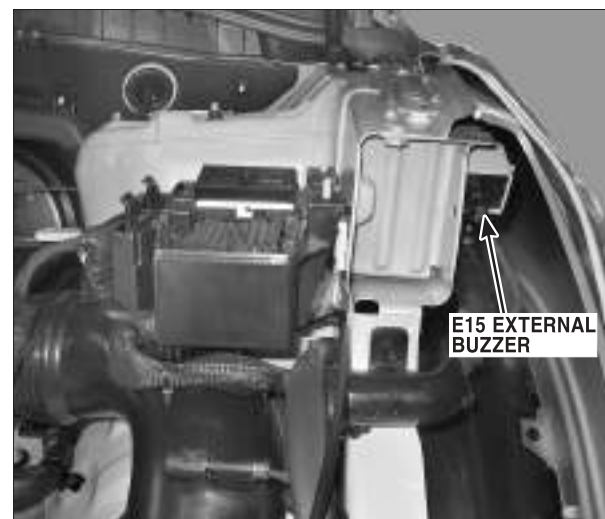
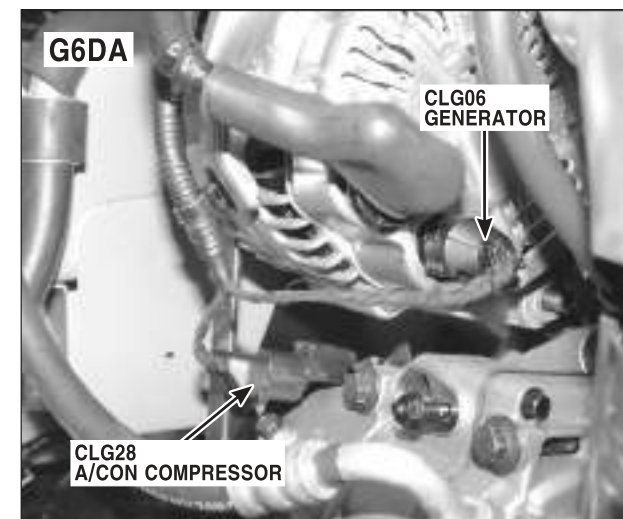

PHOTO.42



# COMPONENT LOCATIONS

## Component Locations (8)

CL-8

PHOTO.43

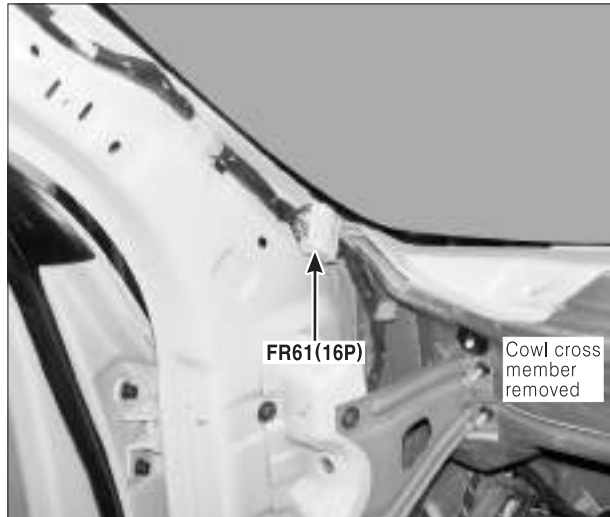

PHOTO.44

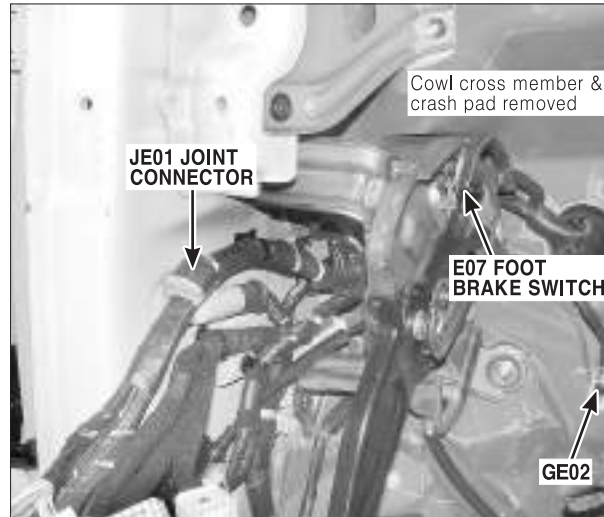

PHOTO.45

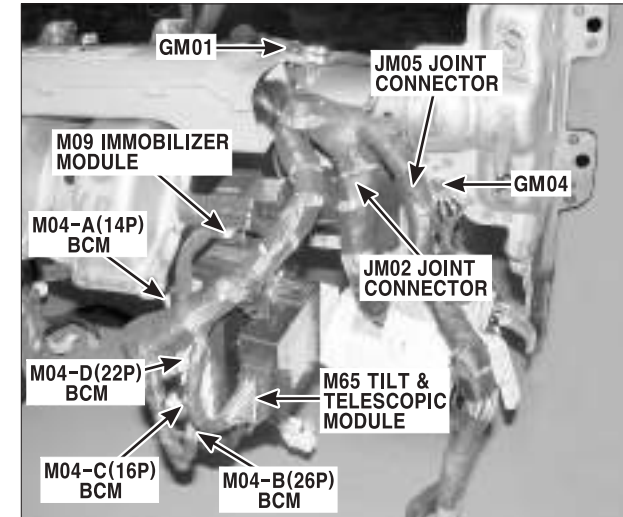

PHOTO.46

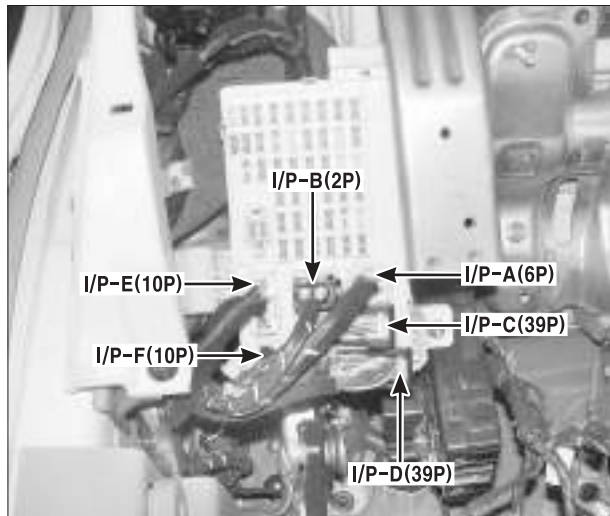

PHOTO.47

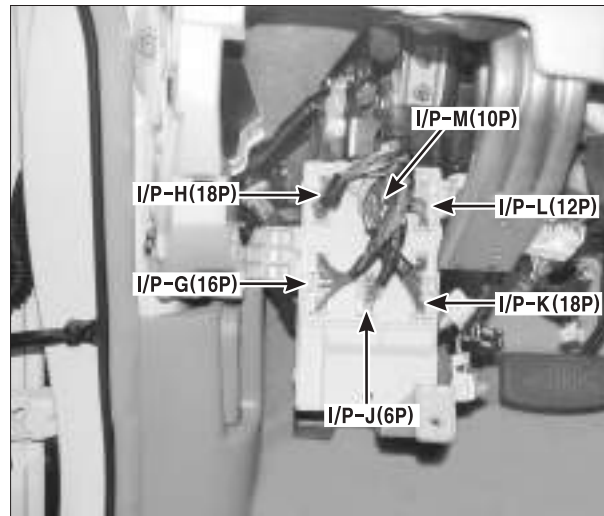
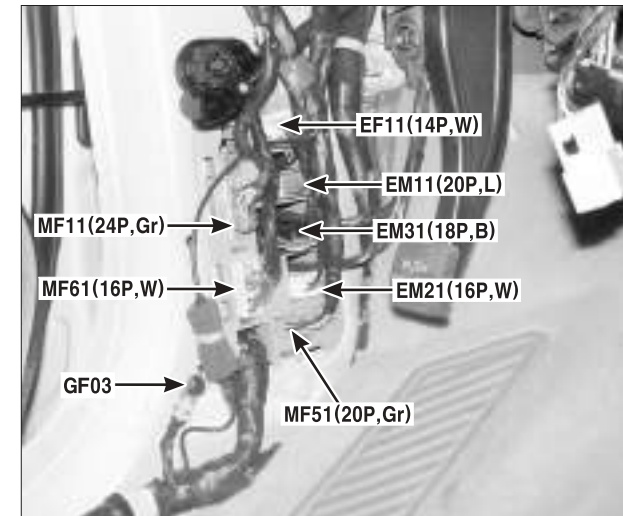

PHOTO.48



# COMPONENT LOCATIONS

## Component Locations (9)

CL-9

PHOTO.49

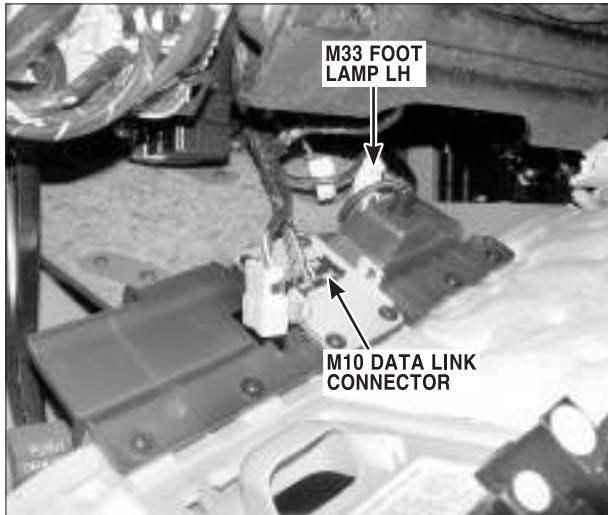

PHOTO.50

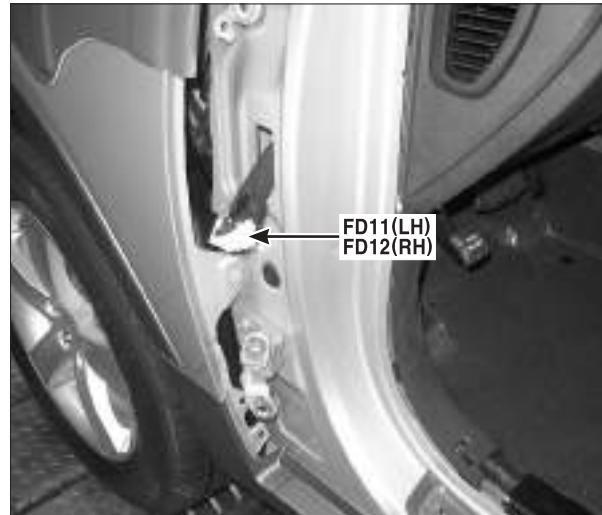

PHOTO.51

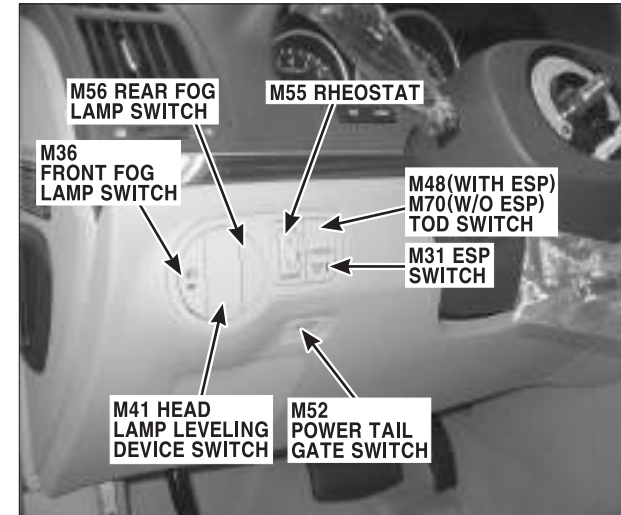

PHOTO.52

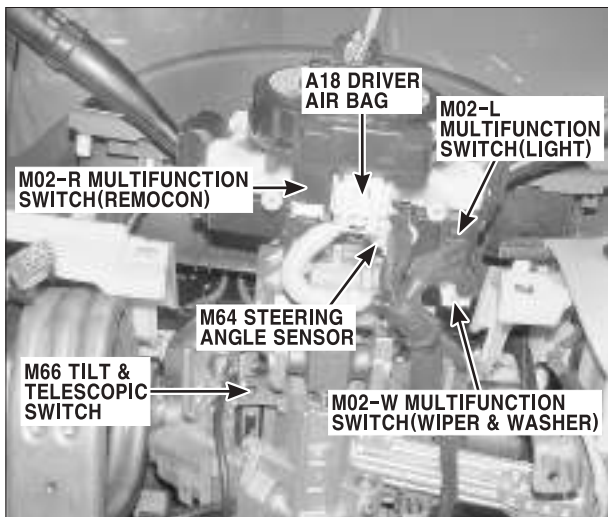

PHOTO.53

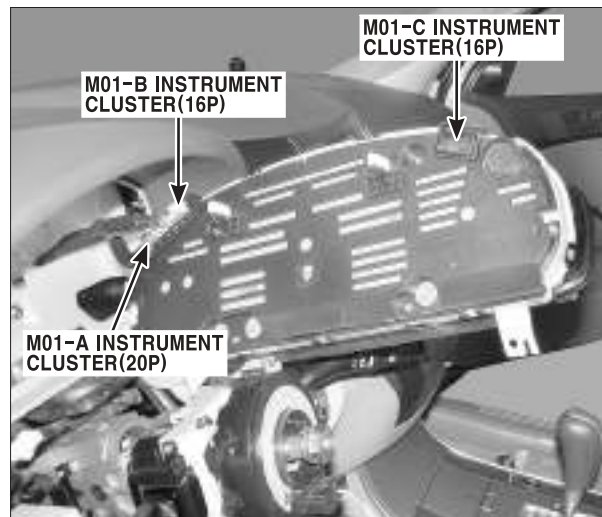

PHOTO.54





# COMPONENT LOCATIONS

## Component Locations (10)

CL-10

PHOTO.55

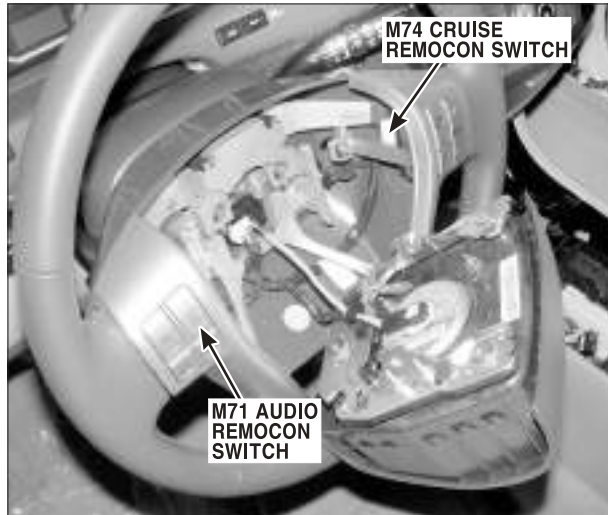

PHOTO.56

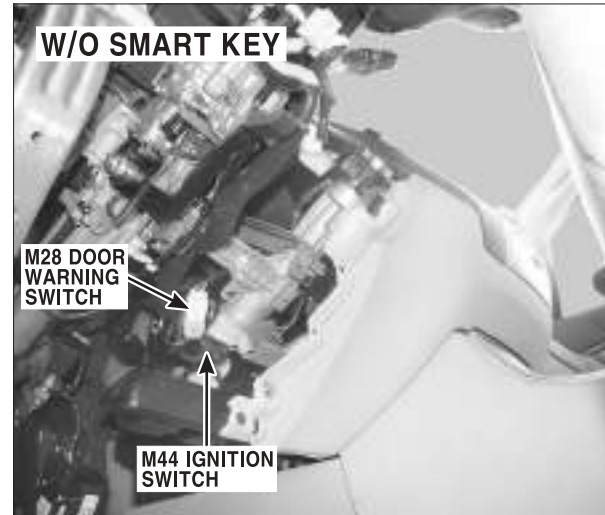

PHOTO.57

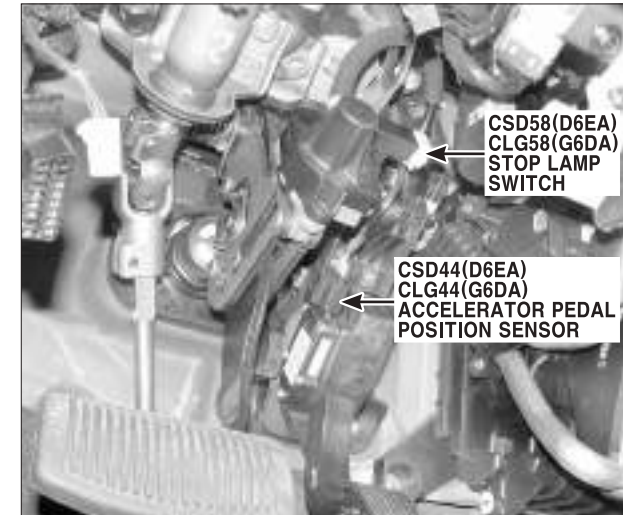

PHOTO.58

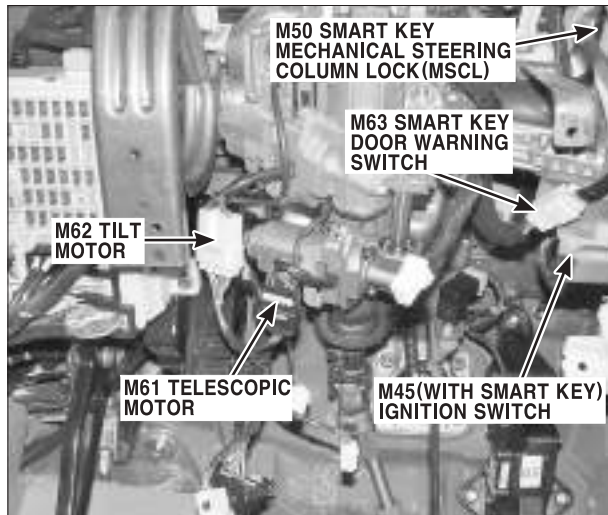

PHOTO.59

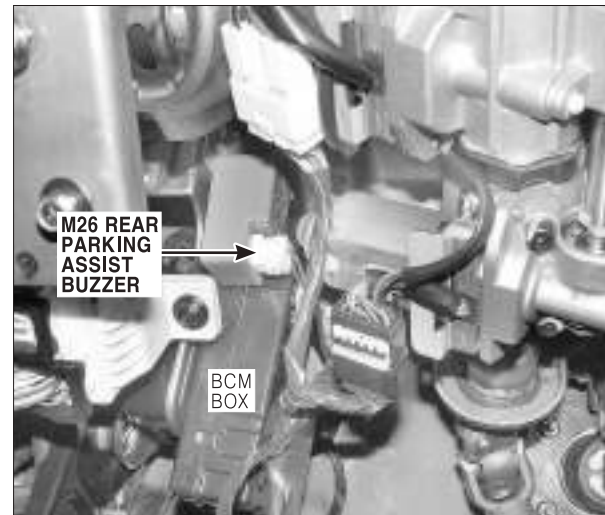
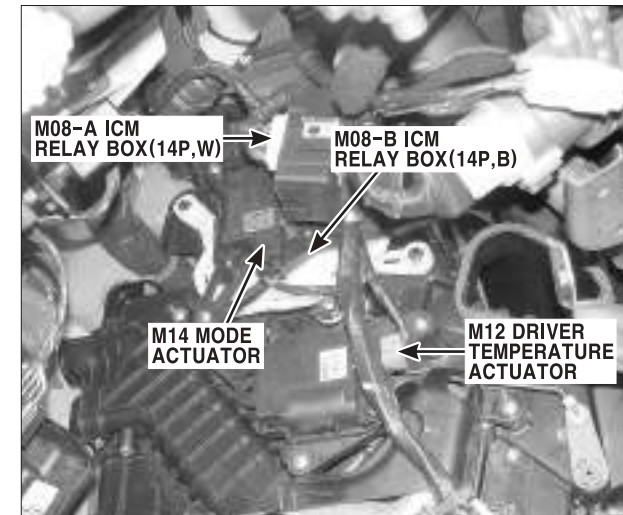

PHOTO.60





# COMPONENT LOCATIONS

## Component Locations (11)

CL-11

PHOTO.61

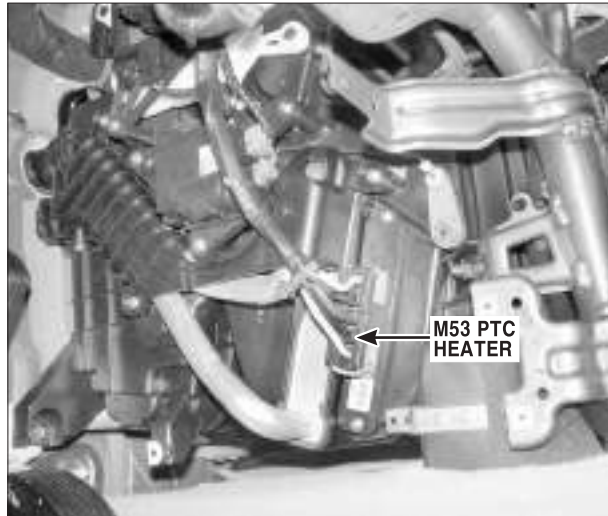

PHOTO.62



PHOTO.63

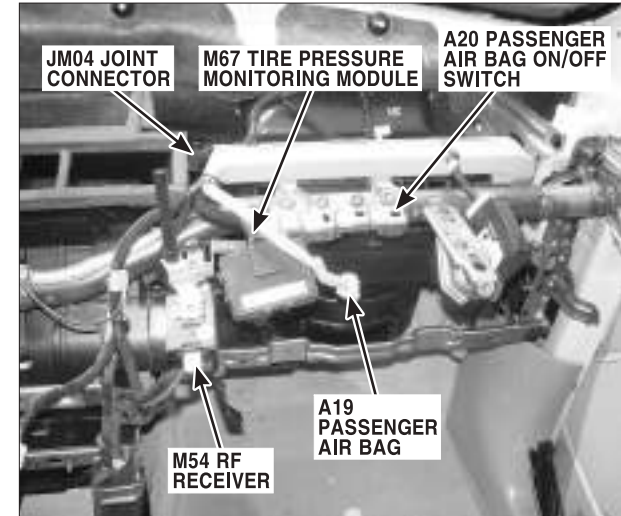

PHOTO.64

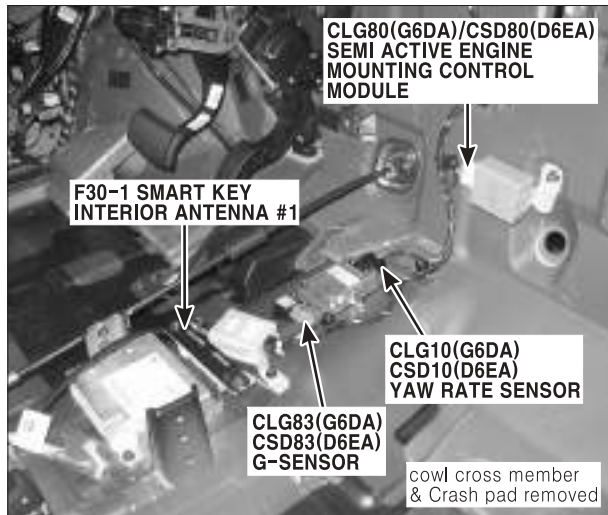

PHOTO.65

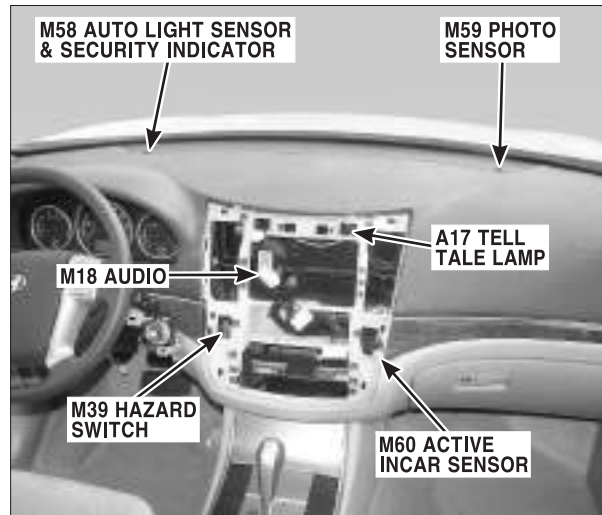
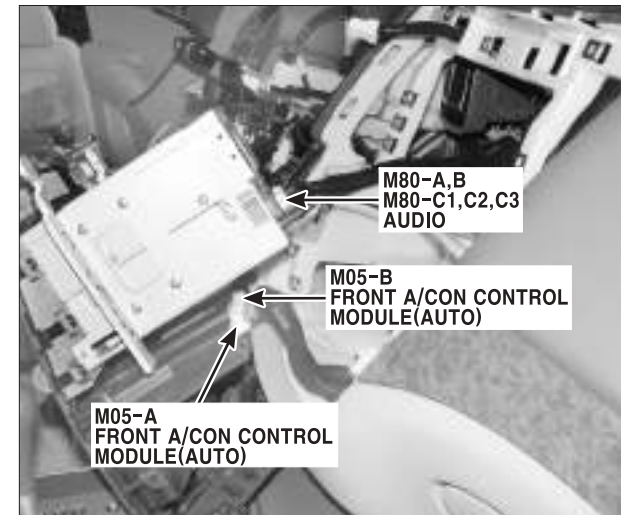

PHOTO.66



# COMPONENT LOCATIONS

## Component Locations (12)

CL-12

PHOTO.67

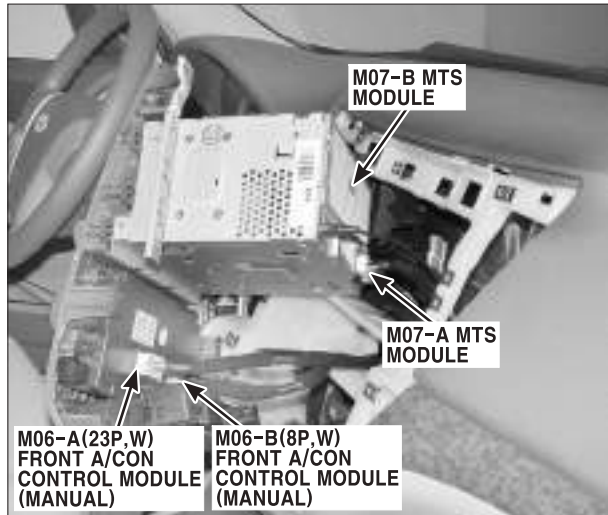

PHOTO.68

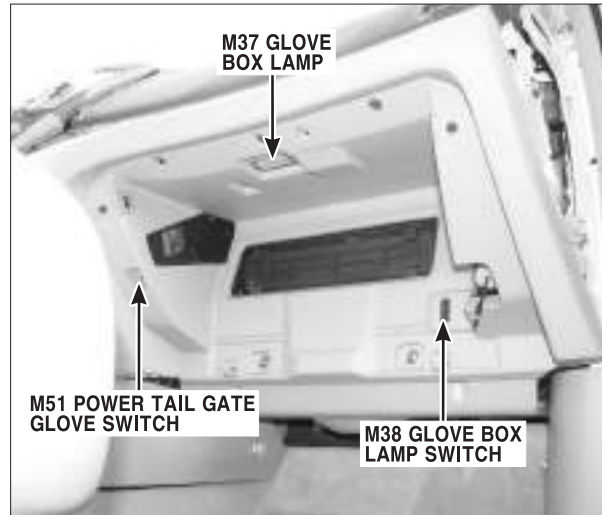

PHOTO.69

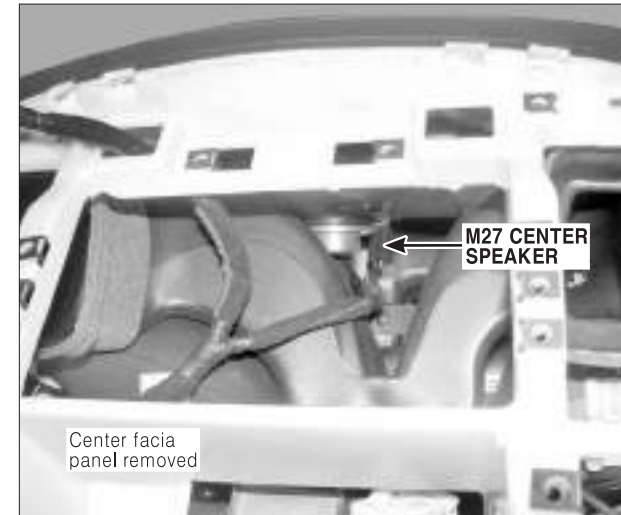

PHOTO.70

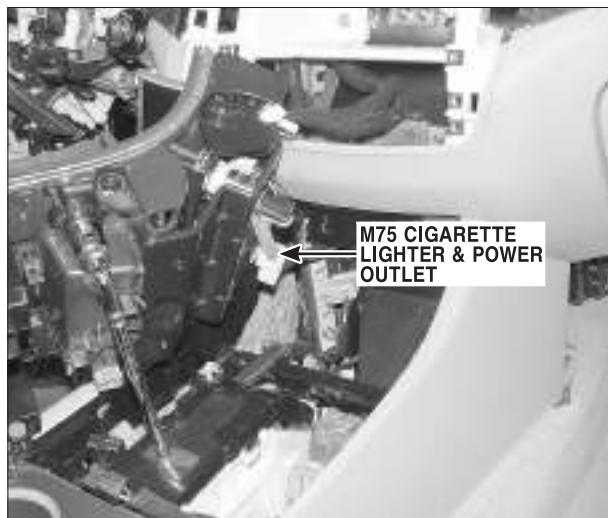

PHOTO.71

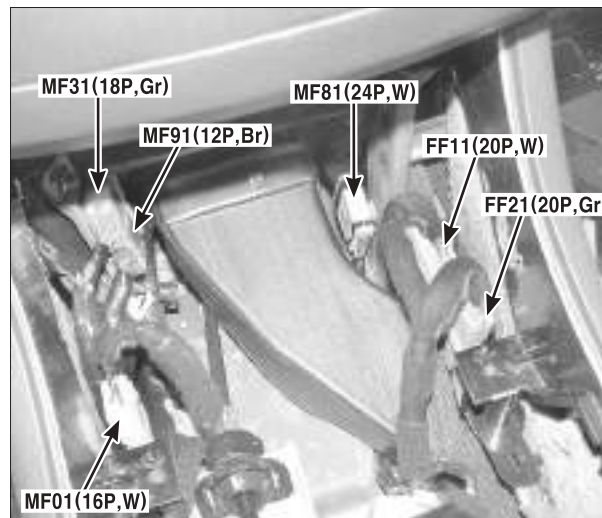
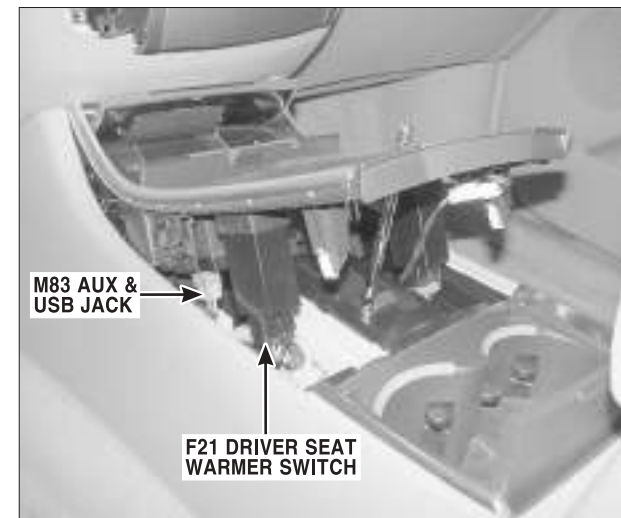

PHOTO.72



# COMPONENT LOCATIONS

## Component Locations (13)

CL-13

PHOTO.73

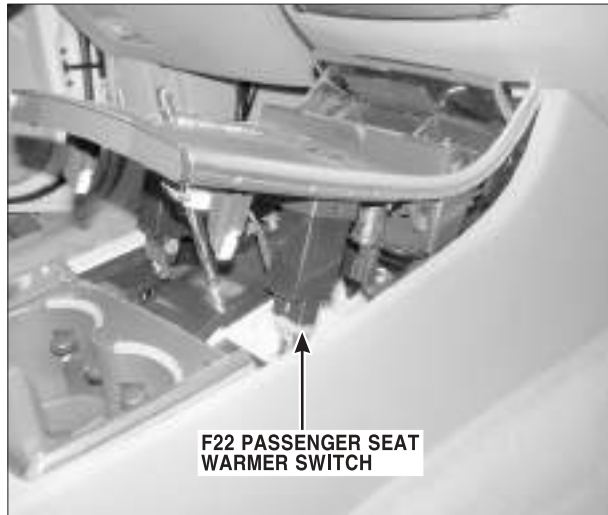

PHOTO.74

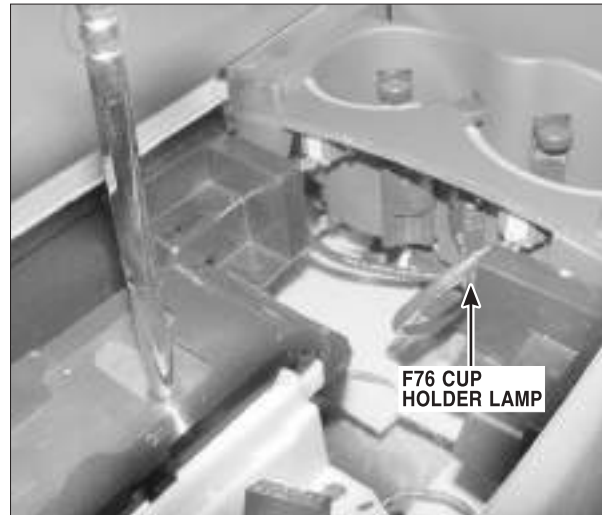

PHOTO.75

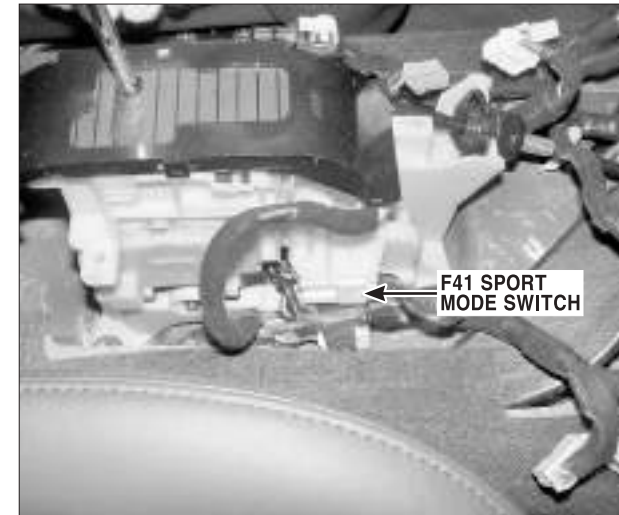

PHOTO.76

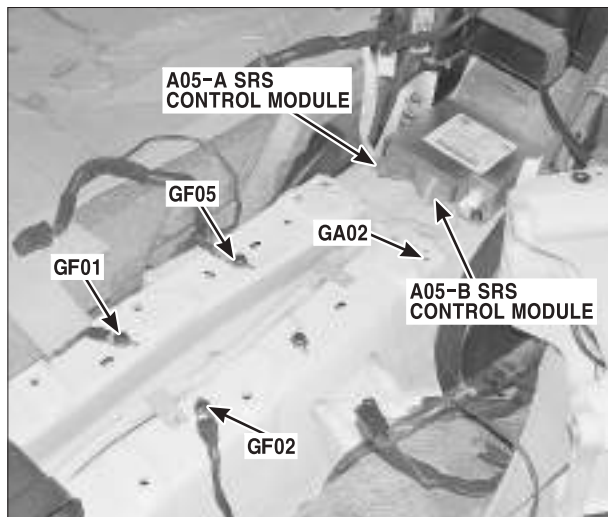
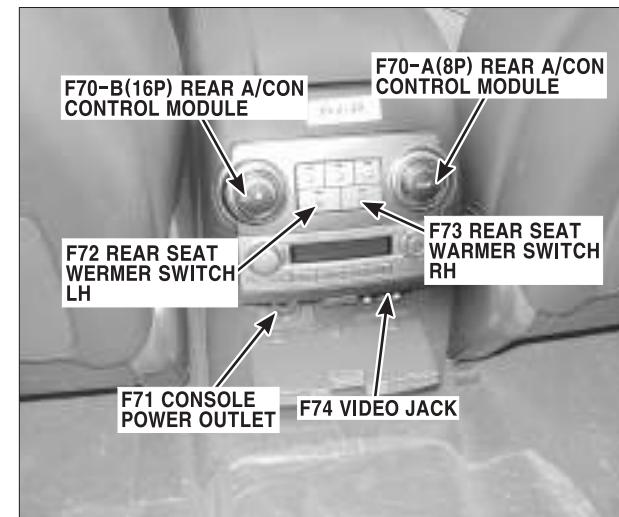

PHOTO.77



PHOTO.78





# COMPONENT LOCATIONS

## Component Locations (14)

CL-14

PHOTO.79

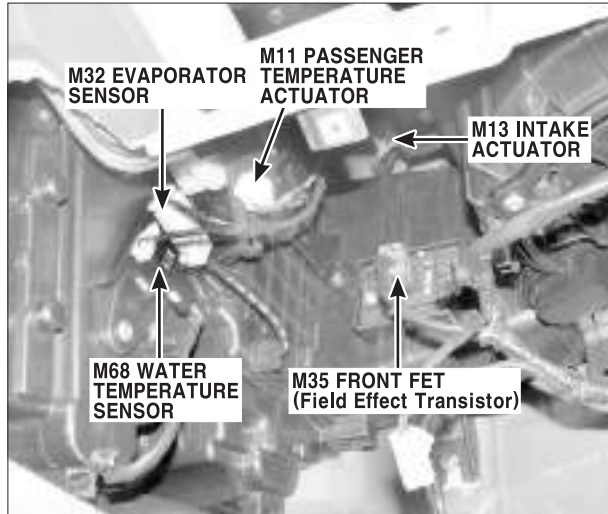

PHOTO.80

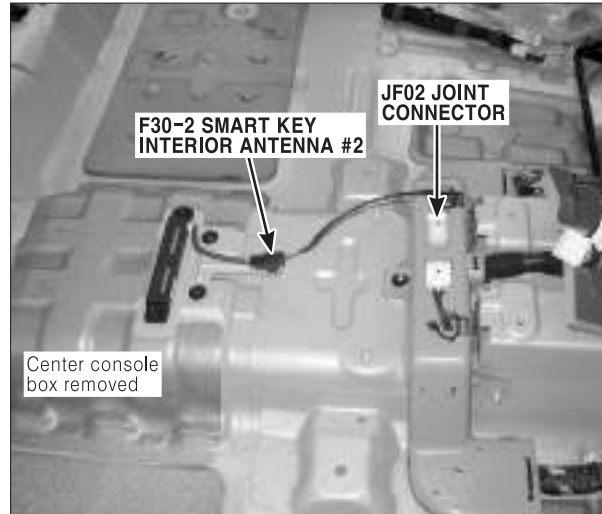

PHOTO.81

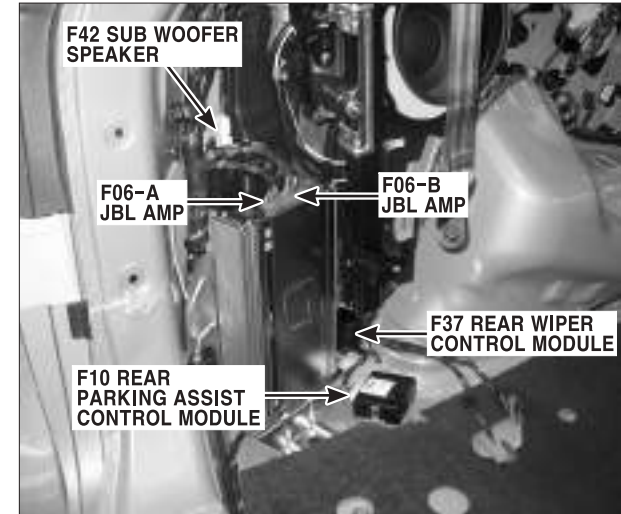

PHOTO.82

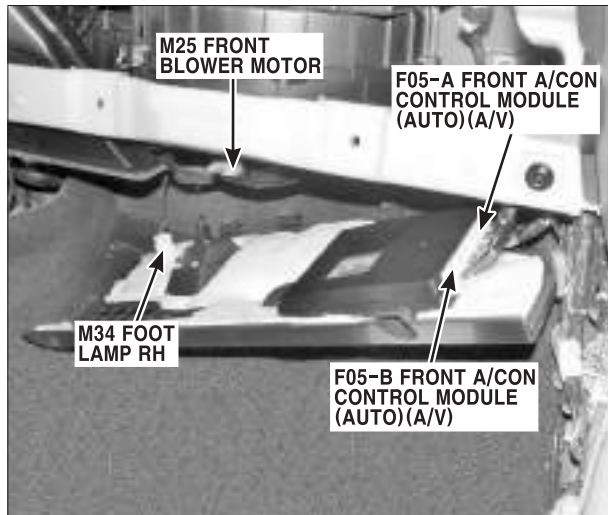

PHOTO.83

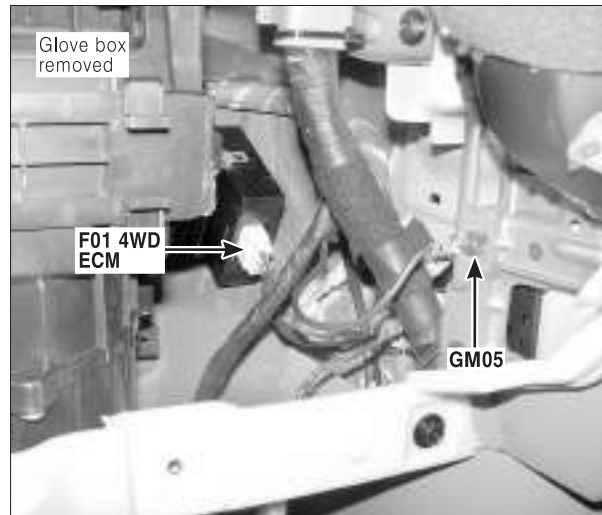
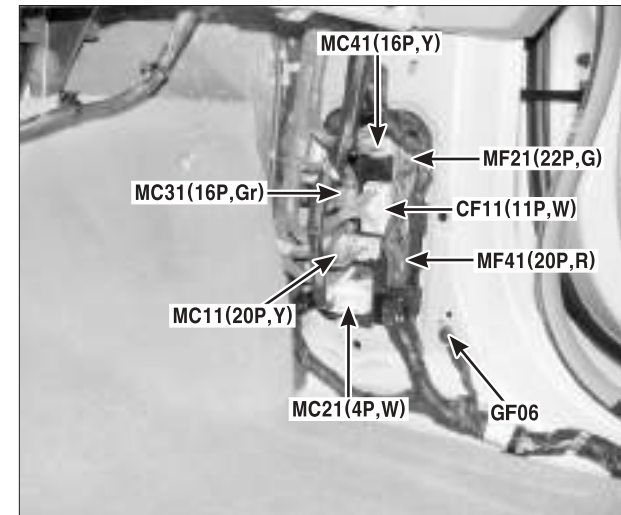

PHOTO.84



# COMPONENT LOCATIONS

## Component Locations (15)

CL-15

PHOTO.85

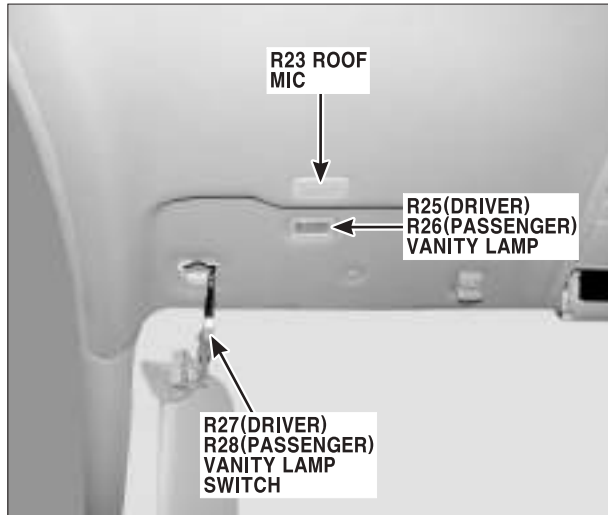

PHOTO.86

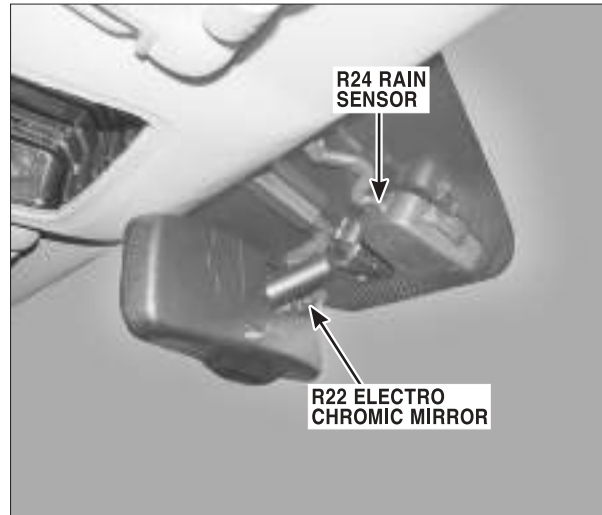

PHOTO.87

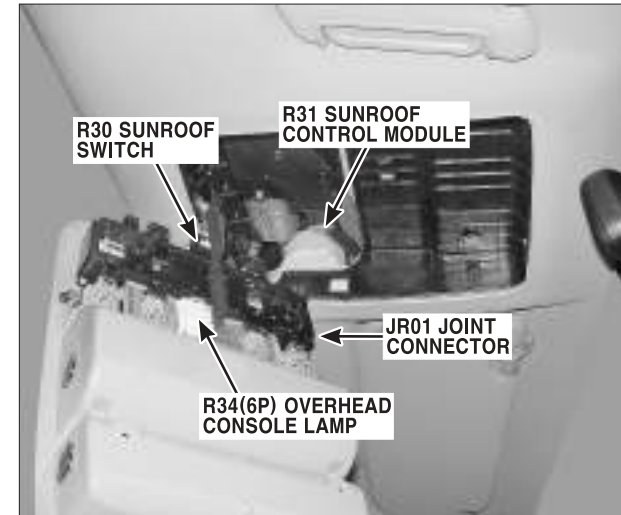

PHOTO.88



PHOTO.89

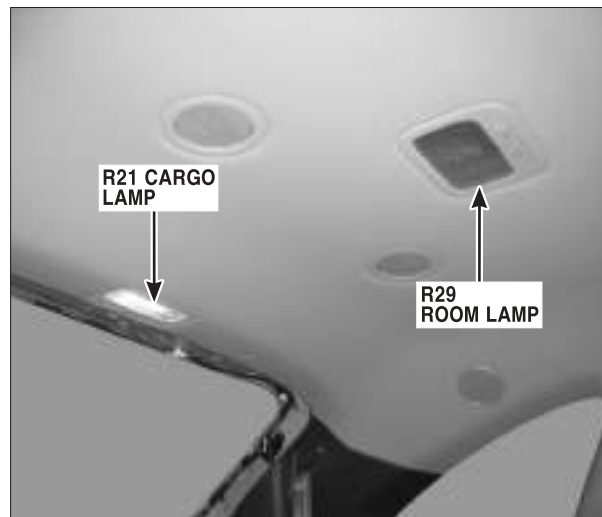

PHOTO.90



# COMPONENT LOCATIONS

## Component Locations (16)

CL-16

PHOTO.91

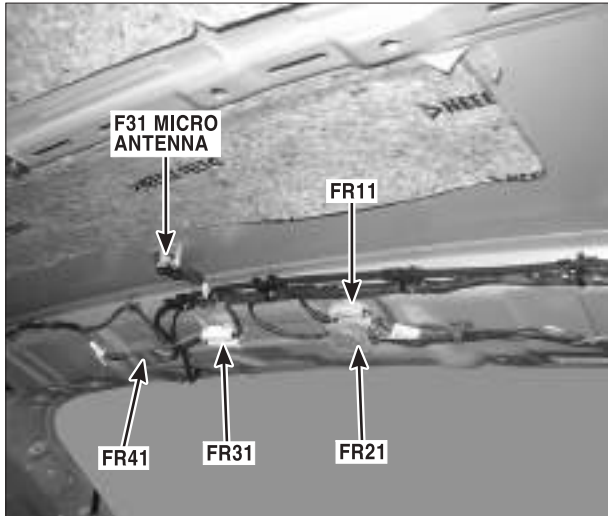

PHOTO.92

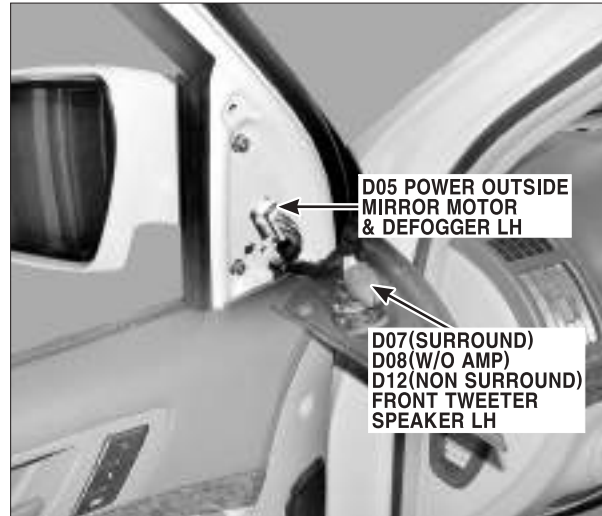

PHOTO.93

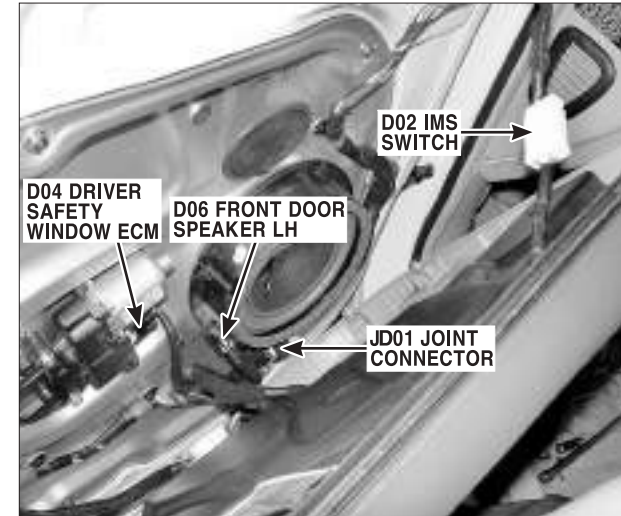

PHOTO.94

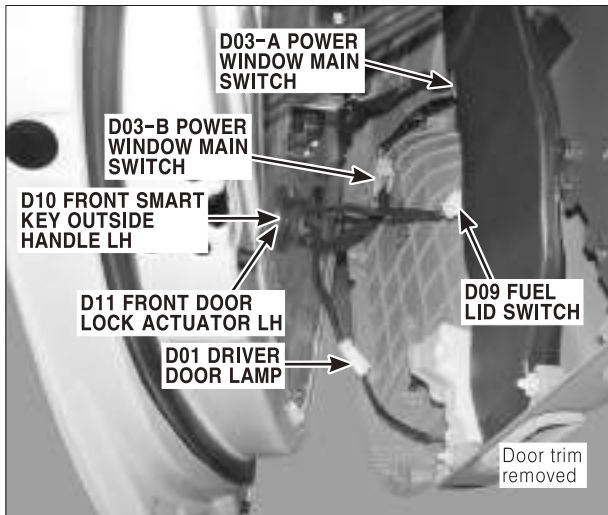

PHOTO.95

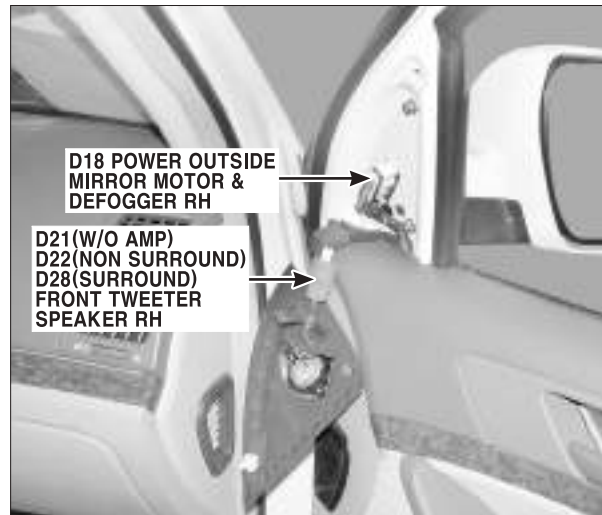
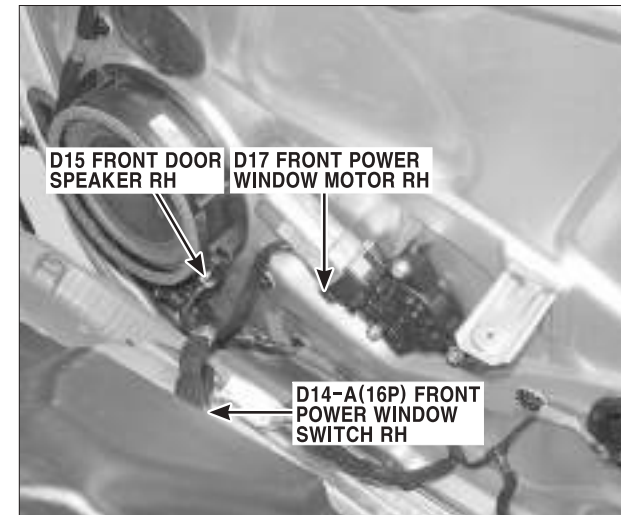

PHOTO.96





# COMPONENT LOCATIONS

## Component Locations (17)

CL-17

PHOTO.97

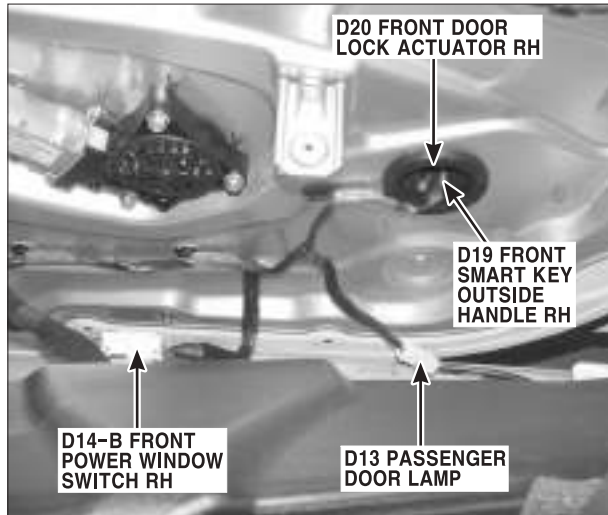

PHOTO.98

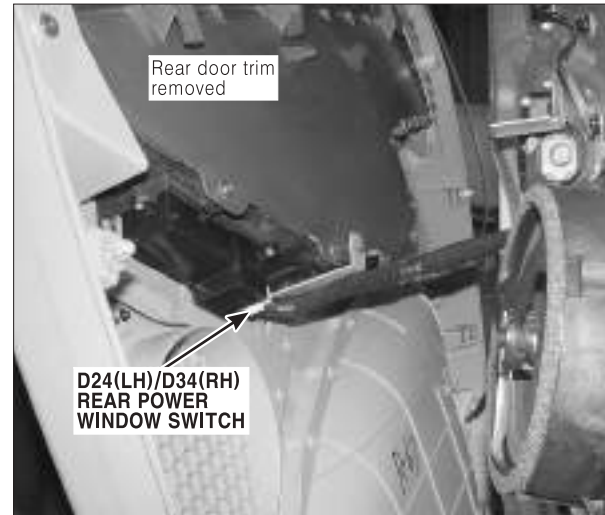

PHOTO.99

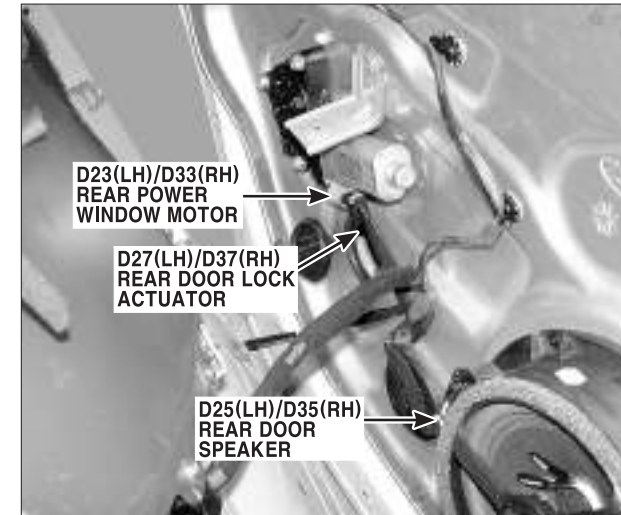

PHOTO.100

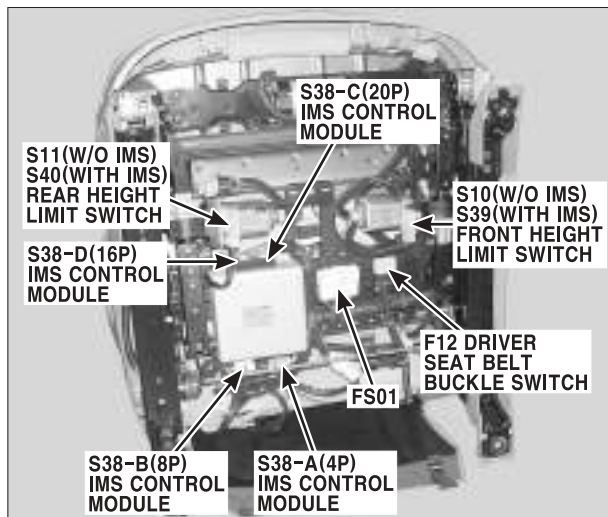

PHOTO.101

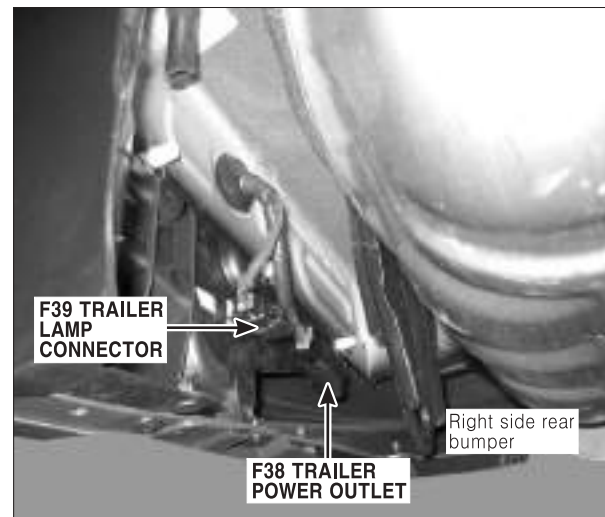
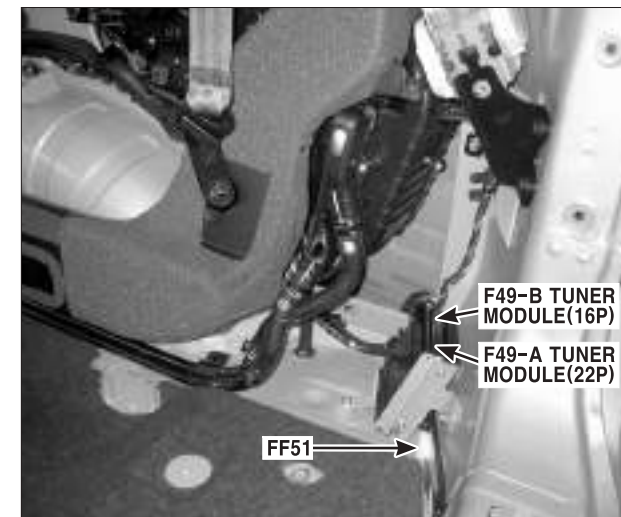

PHOTO.102



**COMPONENT LOCATIONS**

**Component Locations (18)**

**CL-18**

**PHOTO.103**

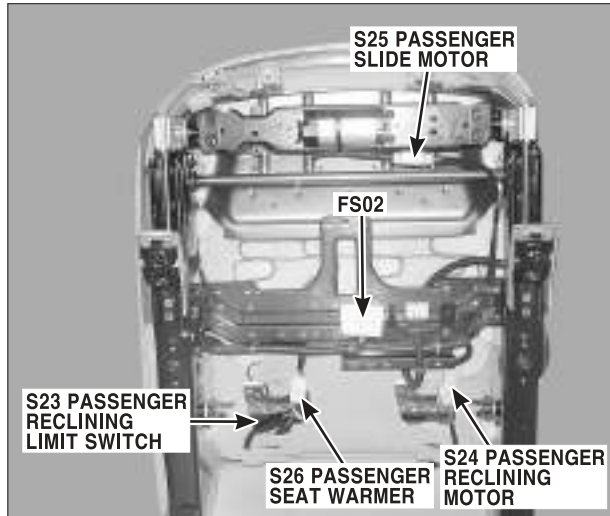

**PHOTO.104**

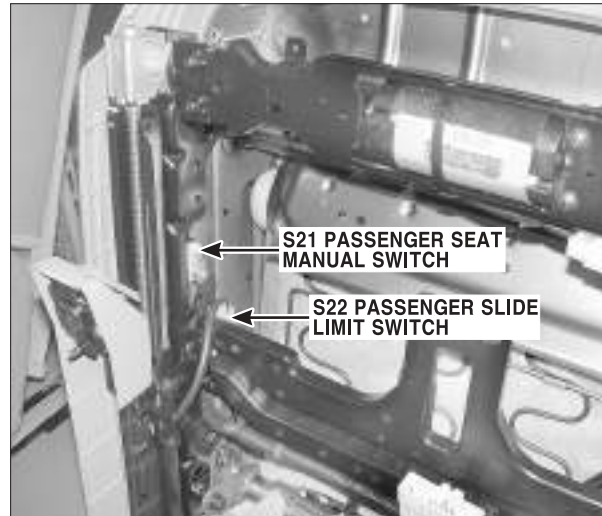

**PHOTO.105**



**PHOTO.106**

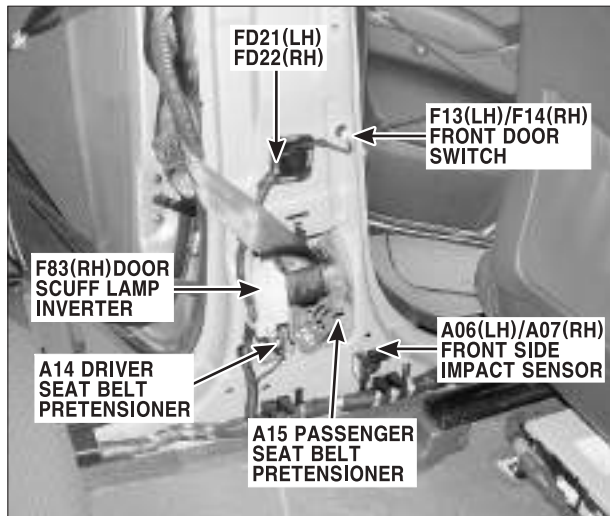

**PHOTO.107**

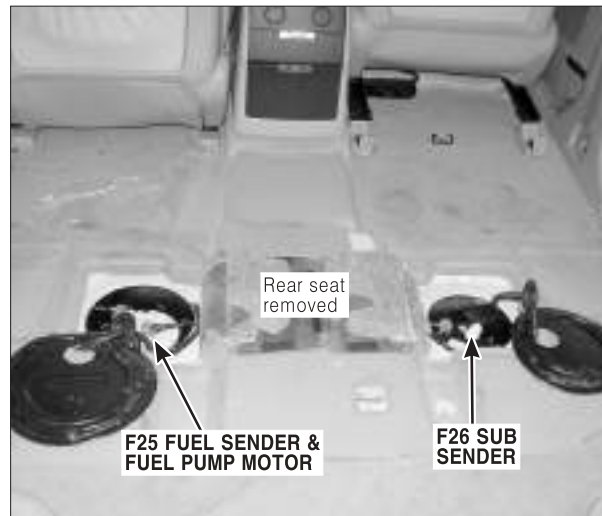

**PHOTO.108**

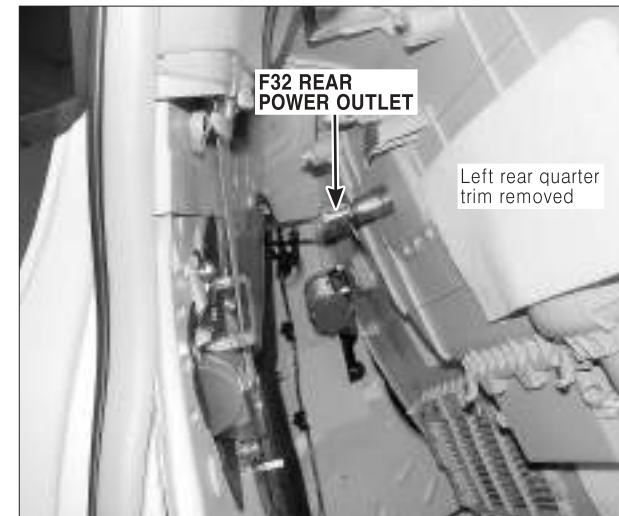



# COMPONENT LOCATIONS

## Component Locations (19)

CL-19

PHOTO.109

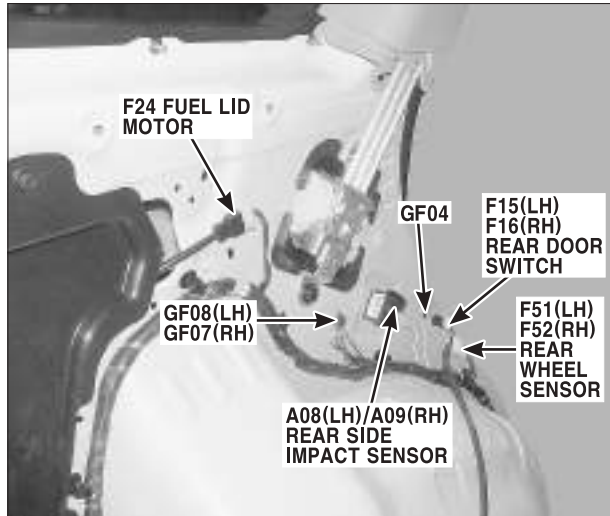

PHOTO.110



PHOTO.111

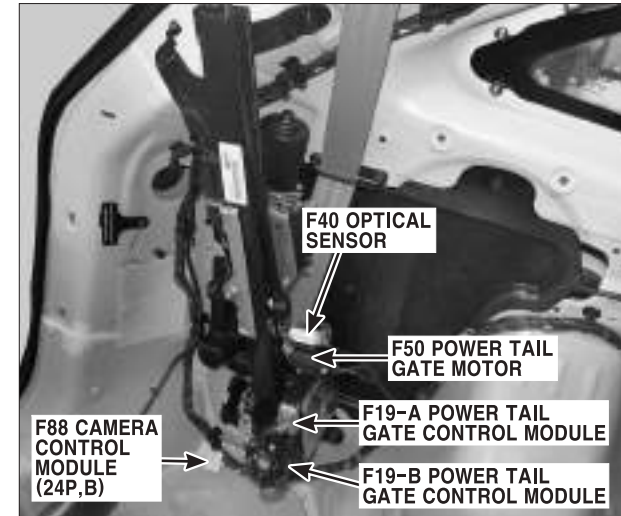

PHOTO.112

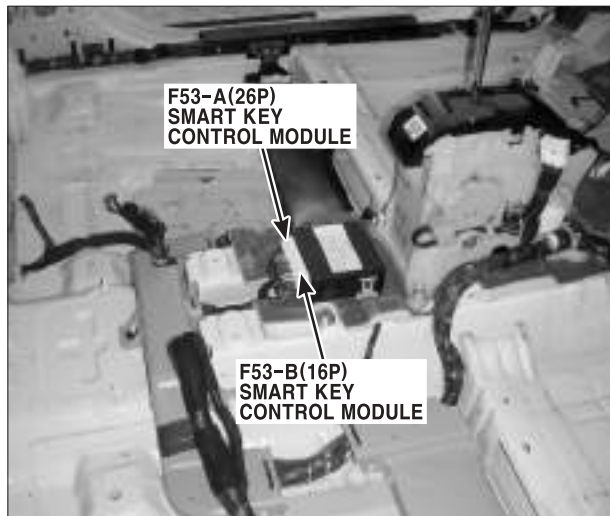
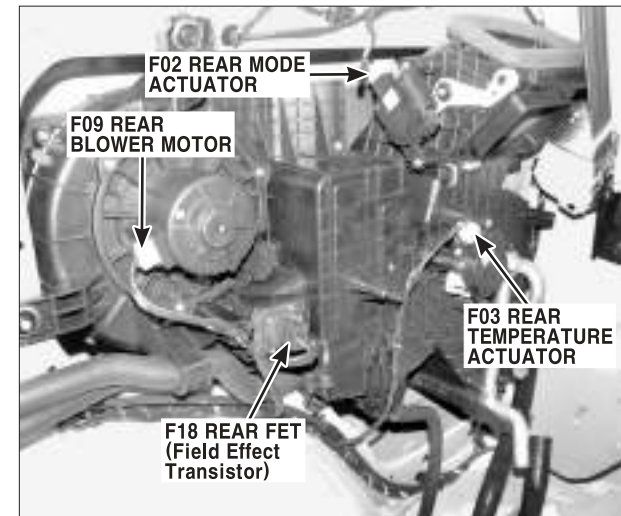

PHOTO.113



PHOTO.114



# COMPONENT LOCATIONS

## Component Locations (20)

CL-20

PHOTO.115

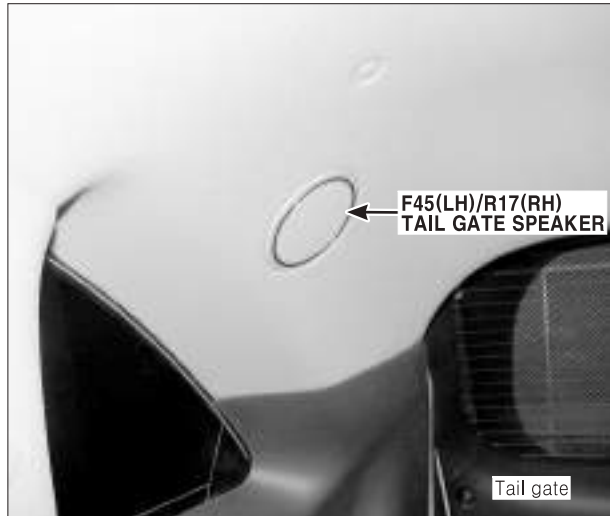

PHOTO.116

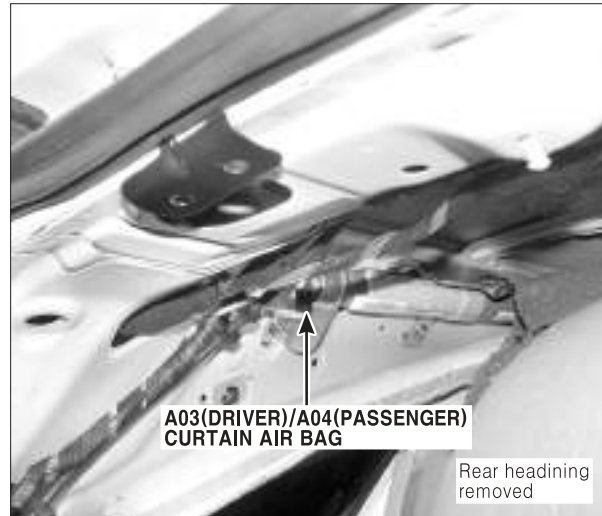

PHOTO.117

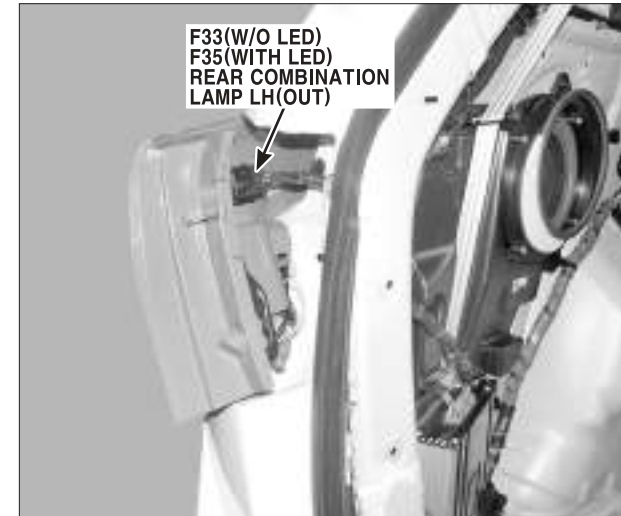

PHOTO.118



PHOTO.119

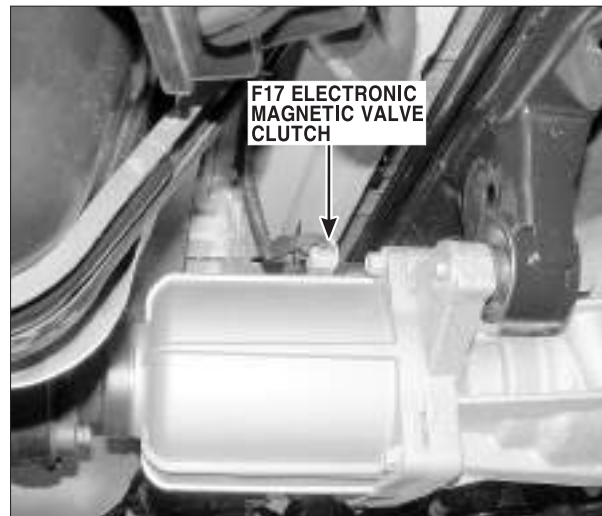

PHOTO.120



**COMPONENT LOCATIONS**

**Component Locations (21)**

**CL-21**

**PHOTO.121**

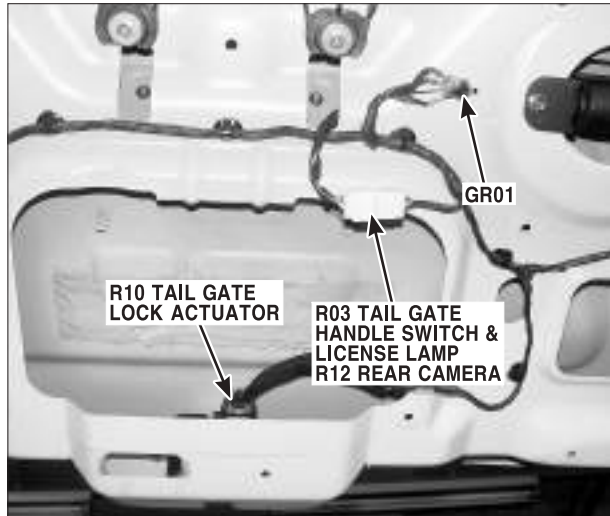

**PHOTO.122**

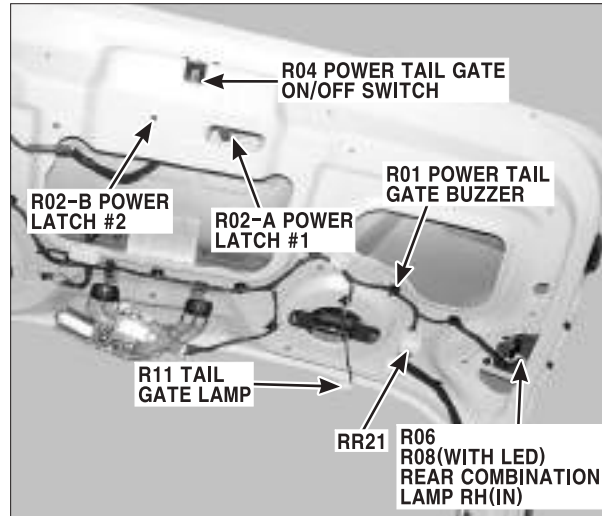

**PHOTO.123**

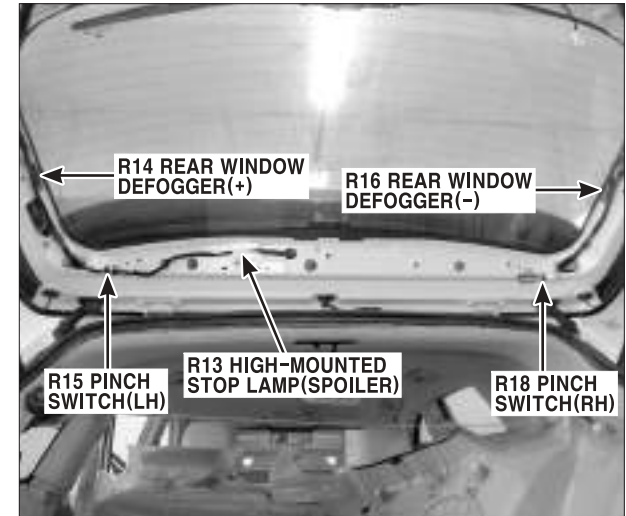

**PHOTO.124**

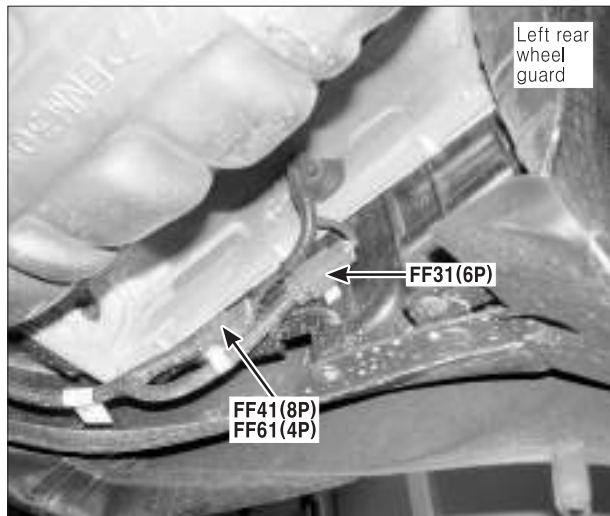

**PHOTO.125**



**PHOTO.126**

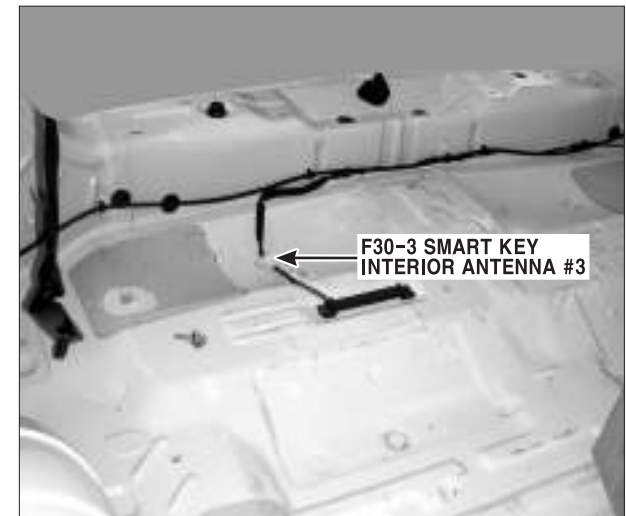



# COMPONENT LOCATIONS

## Component Locations (22)

CL-22

PHOTO.127

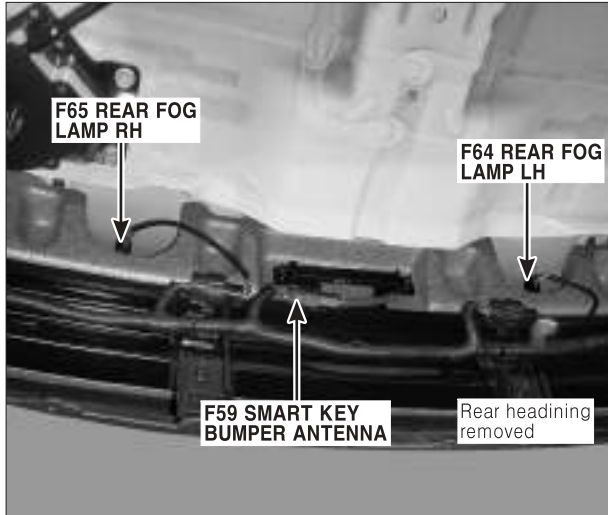

PHOTO.128



PHOTO.129

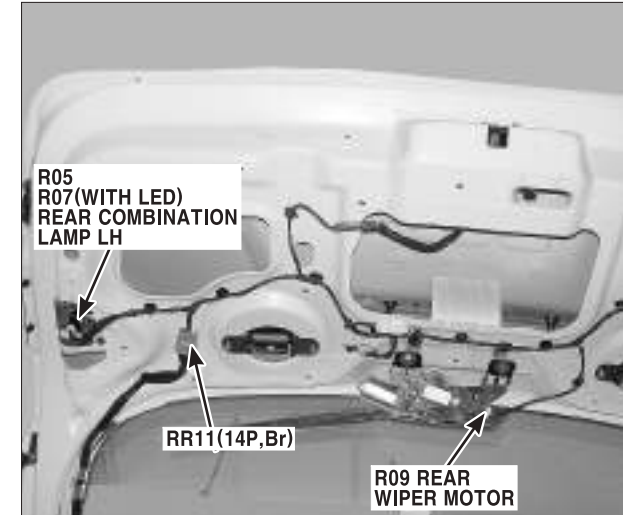

PHOTO.130

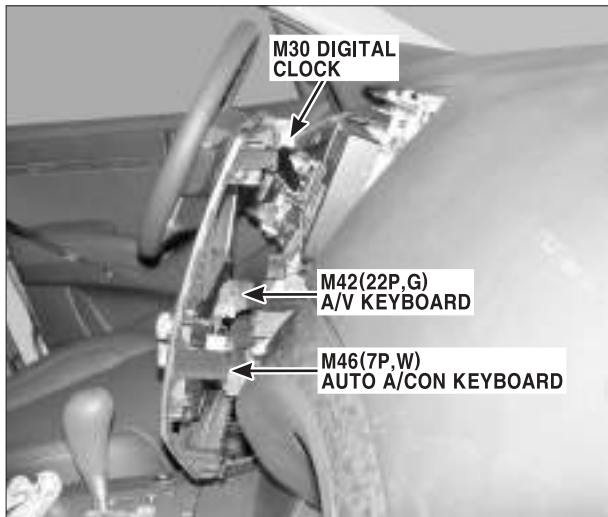

PHOTO.131

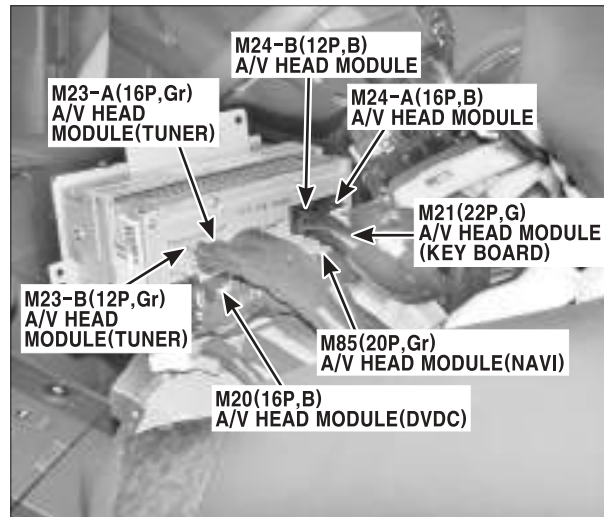

PHOTO.132



# COMPONENT LOCATIONS

## Component Locations (23)

CL-23

PHOTO.133

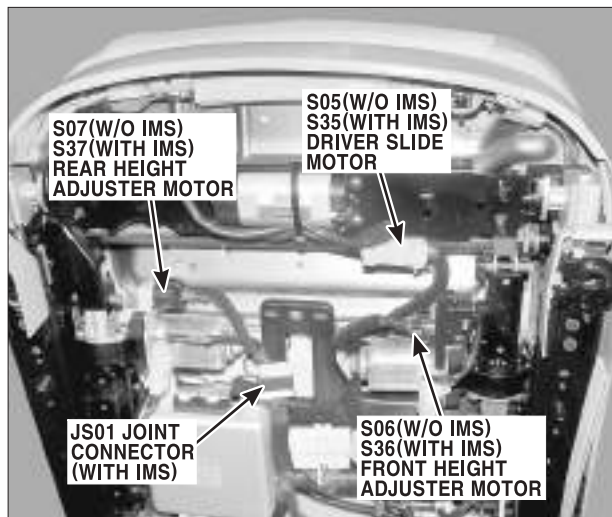

PHOTO.134

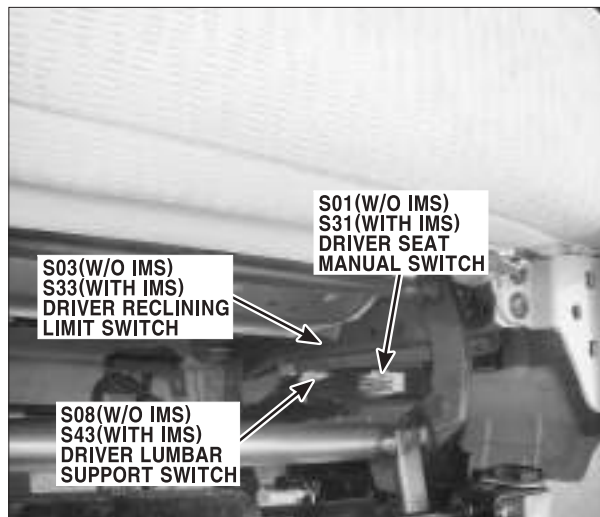
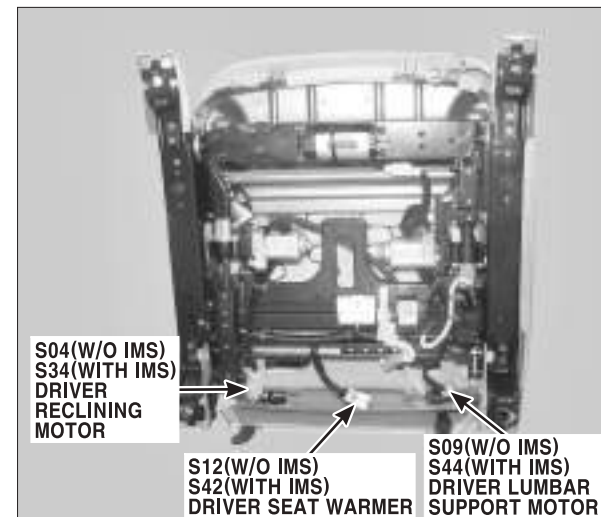

PHOTO.135



# HARNESS CONNECTOR

E88A6D4F

## Harness Connector (1)

CC-1

### CC01

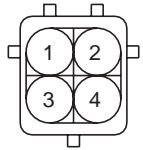

AMP\_EJWP\_04M\_B

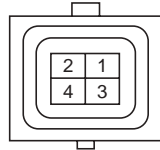

AMP\_368123\_5

### CC02

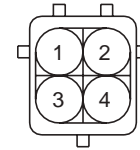

AMP\_EJWP\_04M\_B



AMP\_EJWP\_04F\_B

### CF11

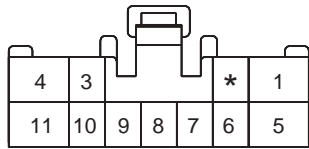

KET\_1809\_11F\_W

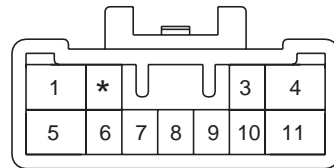

KET\_1809\_11M\_W

### CLGIG



KUM\_KNMWP\_04F\_GR

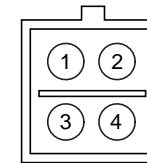

KUM\_PB621\_04120

### CLGINJ

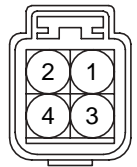

KUM\_NMWP\_04F\_B

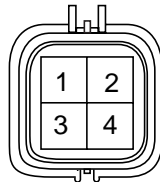

KUM\_PB625\_04020

### CLGOCV

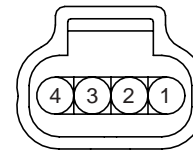

PKD\_GT150\_04F\_Gr

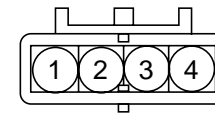

CR04M044

### CSDINJ

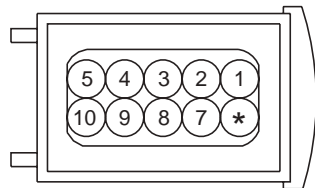

AMP\_JPT\_LEVER\_10F\_B

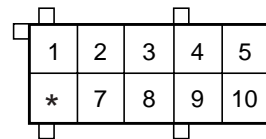

CR10M030

### EC11(GSL/DSL)

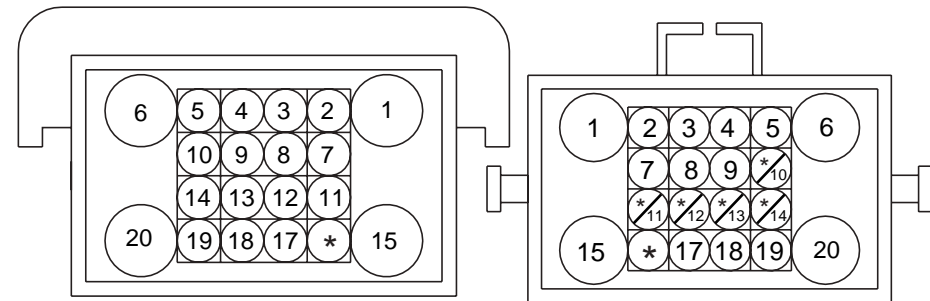

AMP\_MTIJPT\_20F\_B

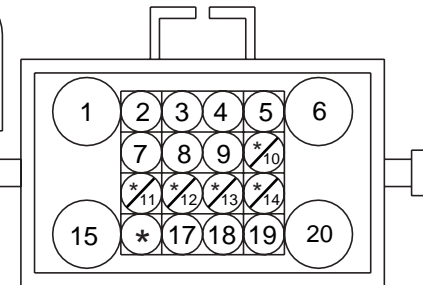

AMP\_MT\_11/JPT(WP)20M\_B(GSL)  
AMP\_MT11JPT\_20M\_B(DSL)

### EC21

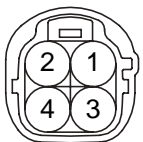

KET\_187IWP\_04F\_B

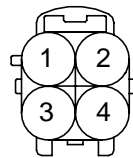

KET\_187IWP\_04M\_B

# HARNES CONNECTOR

## Harness Connector (2)

CC-2

EC31

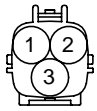

KET\_31211WP\_03M\_B

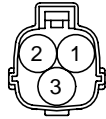

KET\_31211WP\_03F\_B

EC41



KET\_31211WP\_01M\_B



KET\_31211WP\_01F\_B

EE11



KUM\_NMWP\_01M\_B



KUM\_NMWP\_01F\_B

EE21



KUM\_NMWP\_01M\_B



KUM\_NMWP\_01F\_B

EE31

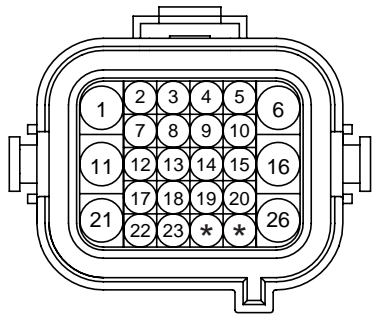

AMP\_MT\_11JPT(WP)\_26M\_B

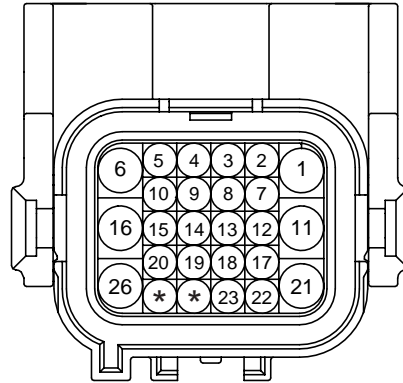

AMP\_MT11JPT\_26F\_B

EF11

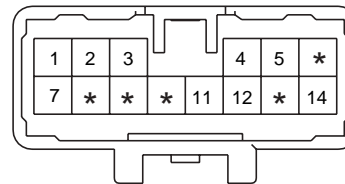

KET\_090III\_14M\_W

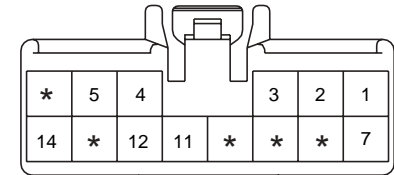

KET\_090III\_14F\_W

EM11

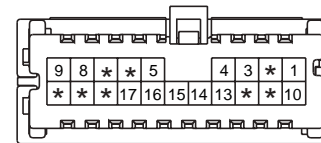

KET\_040III\_20F\_L

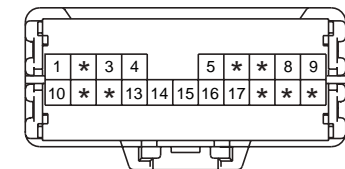

KET\_040III\_20M\_L

EM21

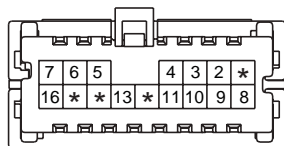

KET\_040III\_16F\_W

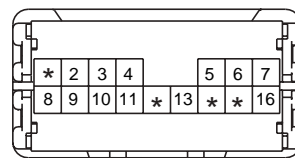

KET\_040III\_16M\_W

EM31

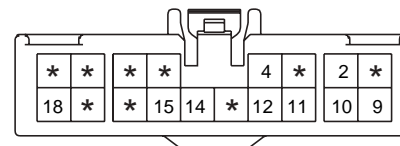

KET\_090III\_18F\_B

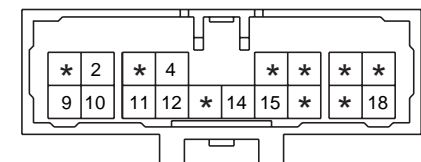

KET\_090III\_18M\_B

# HARNES CONNECTOR

## Harness Connector (3)

CC-3

### FD11

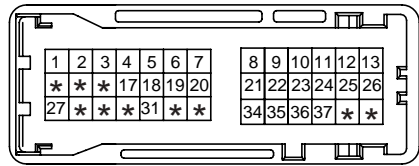

KET\_LIF0409\_39F\_W

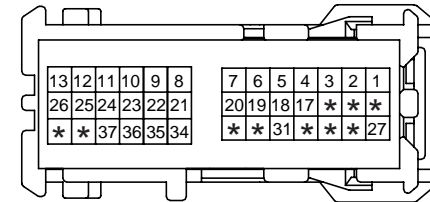

KET\_LIF0409\_39M\_W\_DR

### FD12

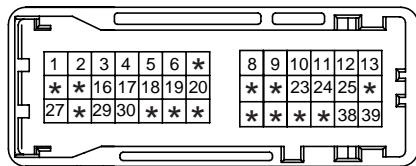

KET\_LIF0409\_39M\_W\_DR

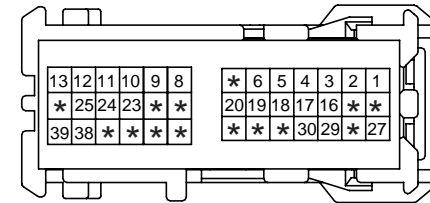

KET\_LIF0409\_39F\_W

### FD21

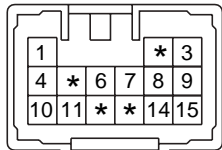

KET\_090III\_15M\_W

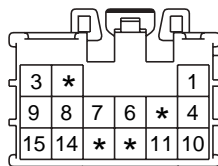

KET\_090III\_15F\_W

### FD22

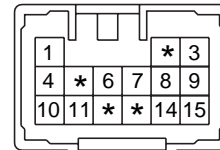

KET\_090III\_15M\_W

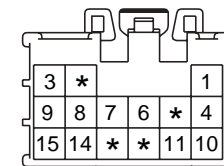

KET\_090III\_15F\_W

### FF11

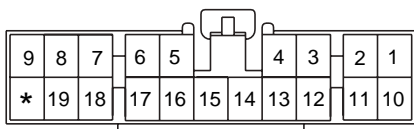

KET\_090III\_20F\_W

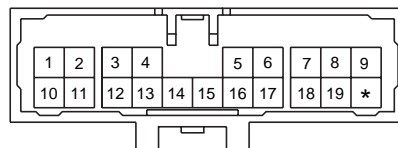

KET\_090III\_20M\_W

### FF21

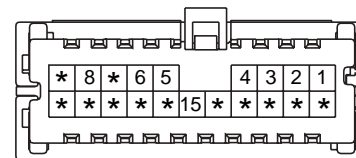

KET\_040III\_20F\_GR

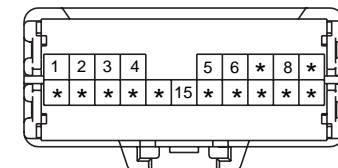

KET\_040III\_20M\_GR

### FF31

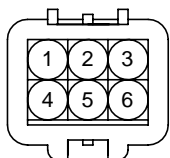

KUM\_NMWP\_06M\_B

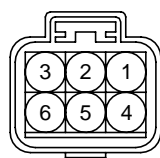

KUM\_NMWP\_06F\_B

### FF41

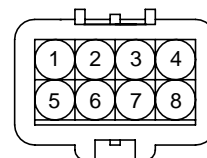

KUM\_NMWP\_08M\_B

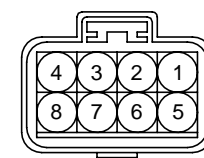

KUM\_NMWP\_08F\_B



# HARNES CONNECTOR

## Harness Connector (4)

CC-4

### FF51

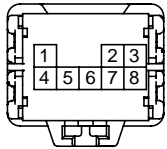

KET\_040III\_08M\_W

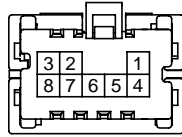

KET\_040III\_08F\_W

### FF61

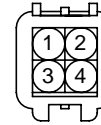

KUM\_NMWP\_04M\_B



KUM\_NMWP\_04F\_B

### FR11

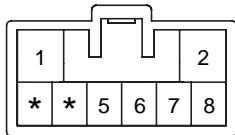

KET\_2507\_08M\_Gr

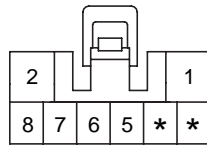

KET\_2507\_08F\_Gr

### FR21

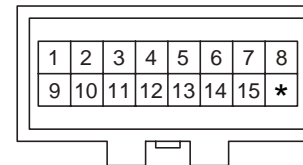

AMP\_090III\_16M\_G

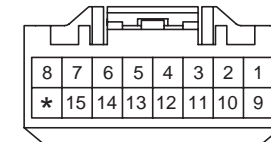

AMP\_090III\_16F\_G

### FR31

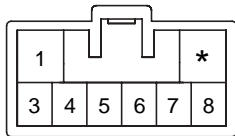

KET\_2507\_08M\_W

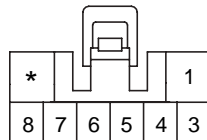

KET\_2507\_08F\_W

### FR41

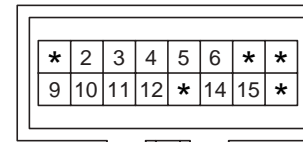

AMP\_090III\_16M\_L

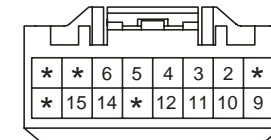

AMP\_090III\_16F\_L

### FR61

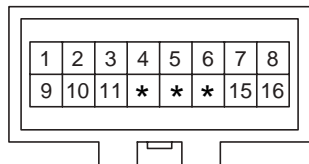

AMP\_090III\_16M\_W

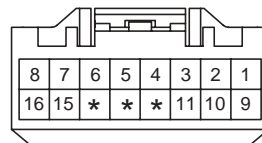

AMP\_090III\_16F\_W

### FS01(With IMS/W/O IMS)

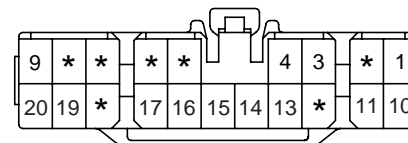

KET\_090II\_20F\_W

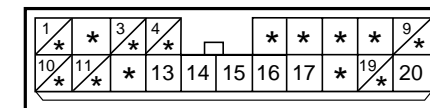

CR20M002

### FS02

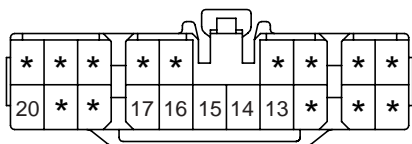

KET\_090II\_20F\_W

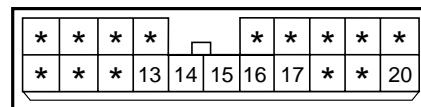

CR20M002

### MC11(GSL/DSL)

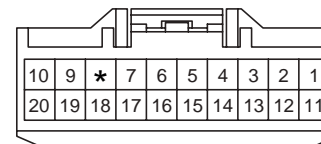

AMP\_090III\_20F\_Y

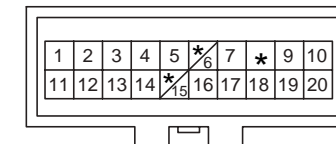

AMP\_090III\_20M\_Y

# HARNESS CONNECTOR

## Harness Connector (5)

CC-5

**MC21**

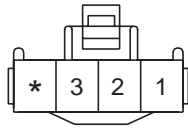

KET\_312II\_04F\_W

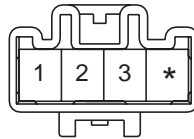

KET\_312II\_04M\_W

**MC31(GSL/DSL)**

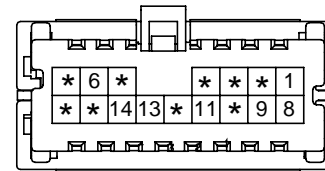

KET\_040III\_16F\_GR

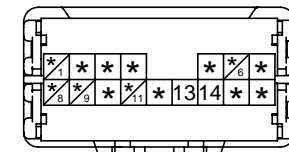

KET\_040III\_16M\_GR

**MC41(GSL/DSL)**

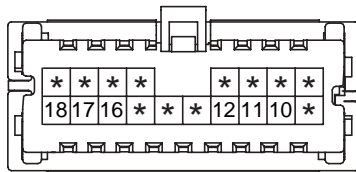

KET\_040III\_18F\_Y

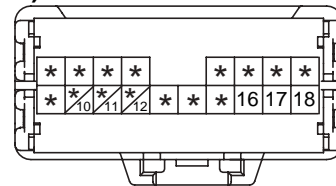

KET\_040III\_18M\_Y

**MF01**

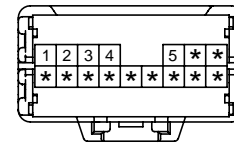

KET\_040III\_16M\_Y

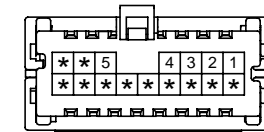

KET\_040III\_16F\_W

**MF11**

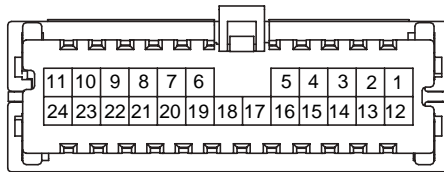

KET\_040III\_24F\_GR

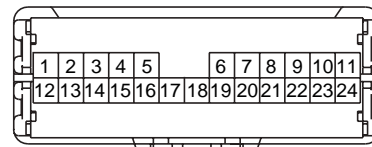

KET\_040III\_24M\_GR

**MF21**

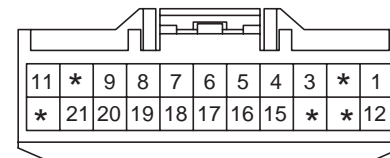

AMP\_090III\_22F\_G

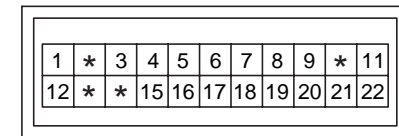

AMP\_090III\_22M\_G

**MF31**

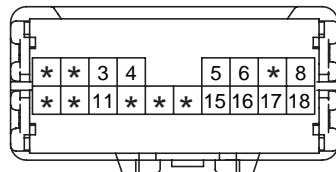

KET\_040III\_18M\_GR

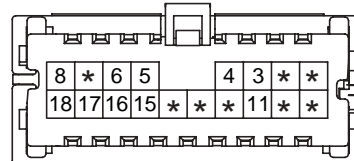

KET\_040III\_18F\_GR

**MF41**

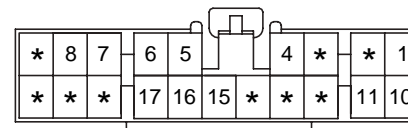

KET\_090III\_20F\_R

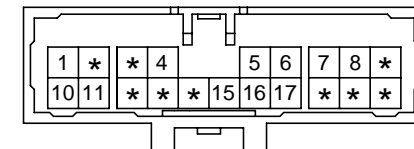

KET\_090III\_20M\_R

**MF51**

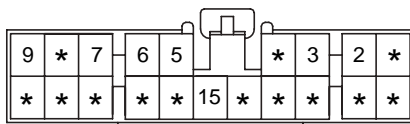

KET\_090II\_20F\_GR

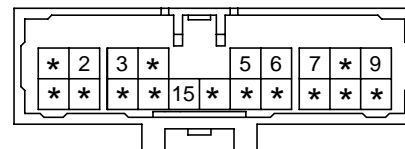

KET\_090II\_20M\_GR

**MF61**

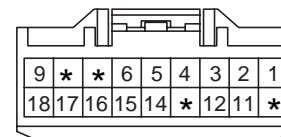

AMP\_090III\_18F\_Y

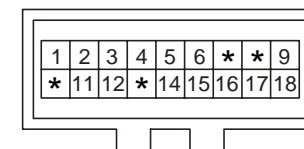

AMP\_090III\_18M\_Y

# HARNESS CONNECTOR

## Harness Connector (6)

CC-6

### MF81

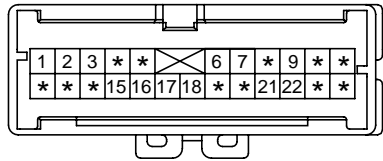

AMP\_040III\_24M\_W

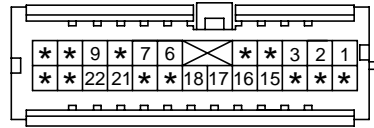

AMP\_040III\_24F\_W

### MF91

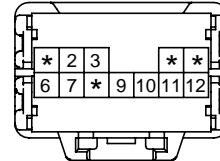

KET\_040III\_12M\_BR

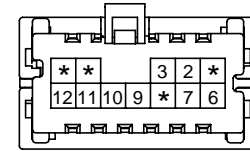

KET\_040III\_12F\_BR

### RR11

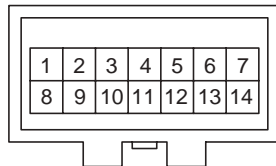

AMP\_090III\_14M\_Br

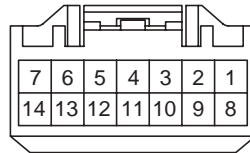

AMP\_090III\_14F\_Br

### RR21

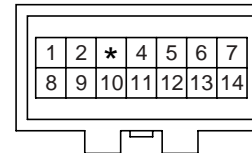

AMP\_090III\_14M\_W

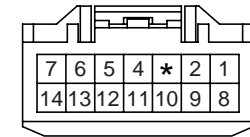

AMP\_090III\_14F\_W

E/R Junction Box (1)

E/R-CLG(GSL)  
E/R-CSD(DSL)

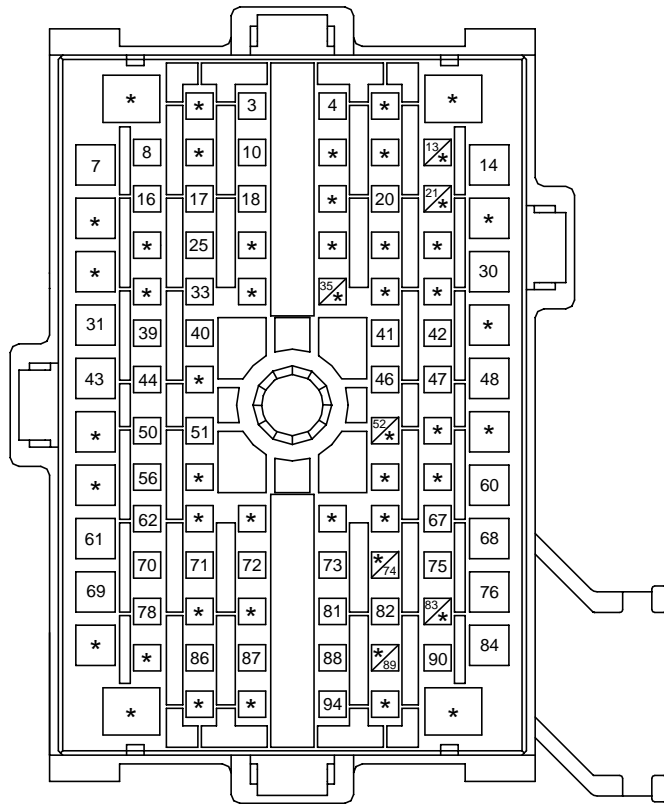

\* GSL ← [diagonal line with number] → DSL

AMP\_MULBOX\_96F\_B

E/R-FRTA

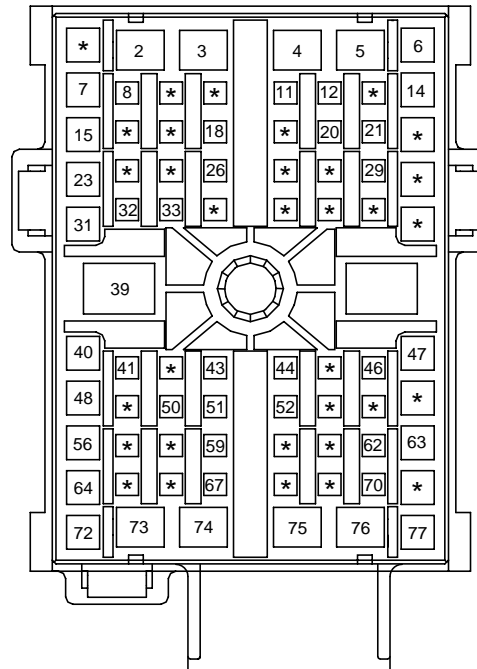

AMP\_MULBOX\_77F\_B

E/R-FRTB

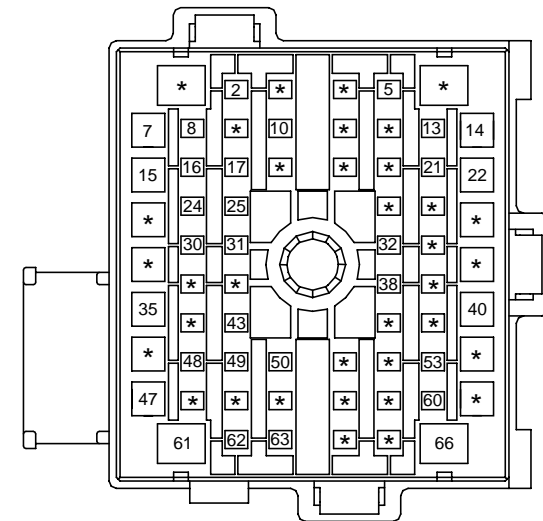

AMP\_MULBOX\_66F\_B\_C

I/P Junction Box (1) CC-8

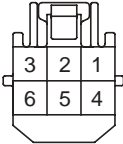
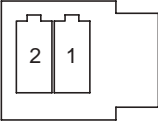
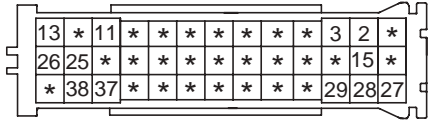
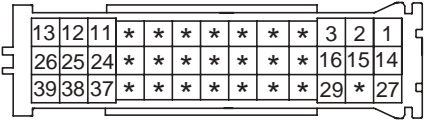
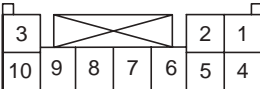
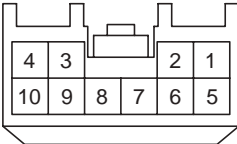
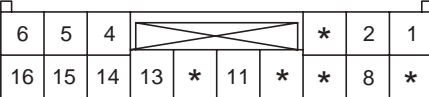
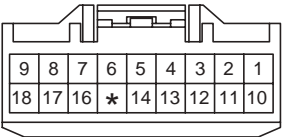
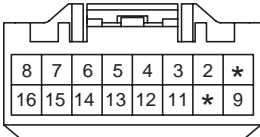
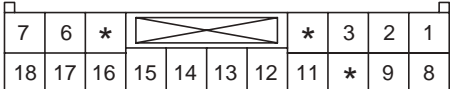
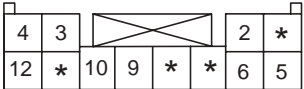
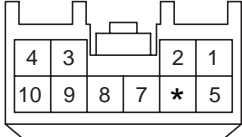
<p><b>I/P-A</b></p>  <p>SUM_187_06F</p>	<p><b>I/P-B</b></p>  <p>AMP_375_02F_B</p>	<p><b>I/P-C</b></p>  <p>AMP_LIF0409_39F_W</p>	<p><b>I/P-D</b></p>  <p>AMP_LIF0409_39F_GR</p>
<p><b>I/P-E</b></p>  <p>AMP_0925_10F_W</p>	<p><b>I/P-F</b></p>  <p>AMP_090III_10F_W</p>	<p><b>I/P-G</b></p>  <p>AMP_0925_16F_W</p>	<p><b>I/P-H</b></p>  <p>AMP_090III_18F_W</p>
<p><b>I/P-J</b></p>  <p>AMP_090III_16F_W</p>	<p><b>I/P-K</b></p>  <p>AMP_0925_18F_W</p>	<p><b>I/P-L</b></p>  <p>AMP_0925_12F_W</p>	<p><b>I/P-M</b></p>  <p>AMP_090III_10F_W</p>

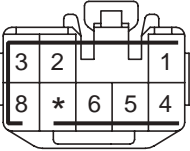
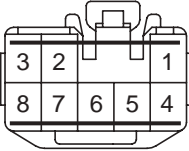
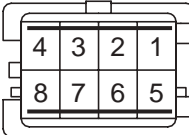
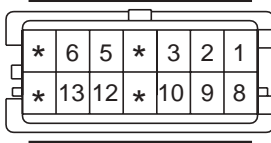
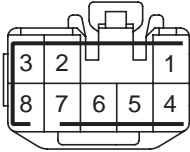
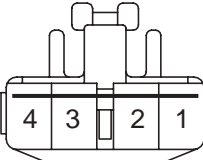
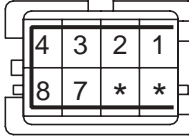
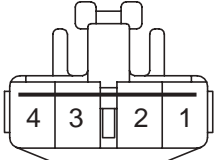
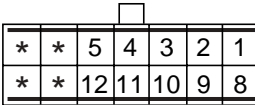
Joint Connector (1)			CC-9
<p><b>JD01</b></p>  <p>KET_090II_08F_W</p>	<p><b>JE01</b></p>  <p>KET_090II_08F_W</p>	<p><b>JF02</b></p>  <p>KET_070_08F_W_JCH</p>	<p><b>JM01</b></p>  <p>KET_070_14F_W_JCH</p>
<p><b>JM02</b></p>  <p>KET_090II_08F_W</p>	<p><b>JM04</b></p>  <p>KET_090II_04F_W</p>	<p><b>JM05</b></p>  <p>KET_070_08F_JCH</p>	<p><b>JR01</b></p>  <p>KET_090II_04F_W</p>
<p><b>JS01</b></p>  <p>CR14F044</p>	<p><b>BLANK</b></p>	<p><b>BLANK</b></p>	<p><b>BLANK</b></p>

Main Harness (1)

HL-1

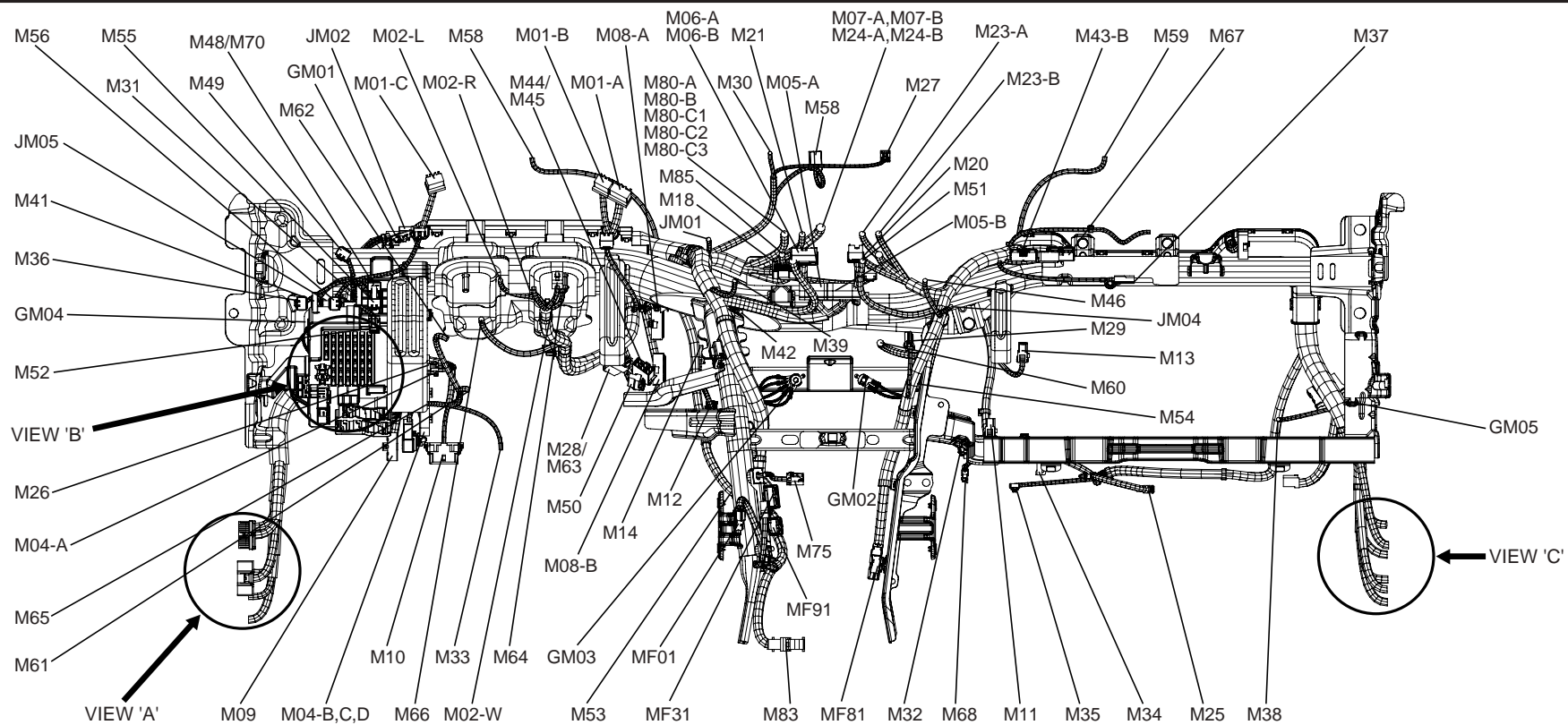

VIEW 'A'

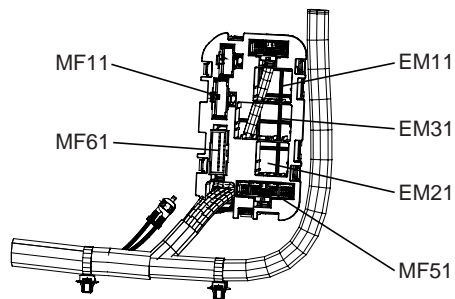

VIEW 'B'

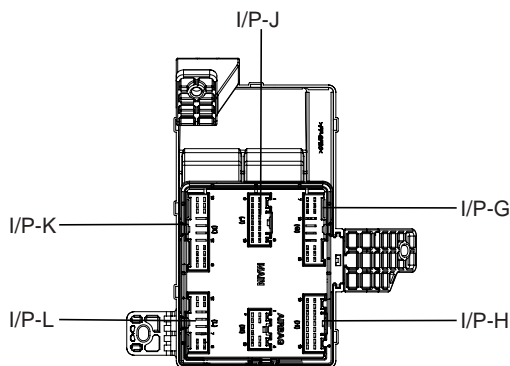

VIEW 'C'

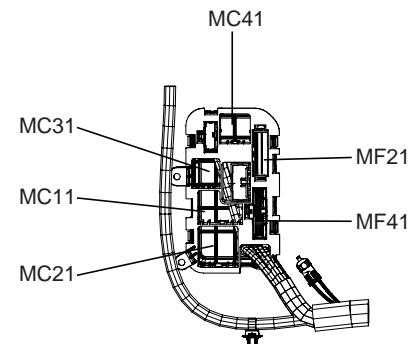

## MAIN HARNESS

### Main Harness (2)

HL-2

#### MAIN HARNESS

M01-A	Instrument cluster	M33	Foot lamp LH	M80-C3	Audio
M01-B	Instrument cluster	M34	Foot lamp RH	M83	AUX & USB jack
M01-C	Instrument cluster	M35	Front FET(Field Effect Transistor)	M85	A/V head module (NAVI)
M02-L	Multifunction switch(Light)	M36	Front fog lamp device switch	MF01	Connection with CONSOLE EXT. harness
M02-R	Multifunction switch(Remocon)	M37	Glove box lamp	MF81	Connection with FLOOR harness
M02-W	Multifunction switch(Wiper)	M38	Glove box switch	MF91	Connection with FLOOR harness
M04-A	BCM	M39	Hazard switch	JM01	Joint connector
M04-B	BCM	M41	Head lamp leveling switch	JM02	Joint connector
M04-C	BCM	M42	A/V keyboard	JM04	Joint connector
M04-D	BCM	M44	Ignition switch(W/O Smart key)	JM05	Joint connector
M05-A	Front A/CON control module(Auto)	M45	Ignition switch(With Smart key)	I/P-G	Connection with I/P JUNCTION BOX
M05-B	Front A/CON control module(Auto)	M46	Auto A/Con keyboard	I/P-H	Connection with I/P JUNCTION BOX
M06-A	Front A/CON control module(Manual)	M48	TOD switch(With ESP)	I/P-J	Connection with I/P JUNCTION BOX
M06-B	Front A/CON control module(Manual)	M49	ODO trip switch	I/P-K	Connection with I/P JUNCTION BOX
M07-A	MTS module	M50	Smart key mechanical steering column lock (MSCL)	I/P-L	Connection with I/P JUNCTION BOX
M07-B	MTS module			EM11	Connection with FRONT harness
M08-A	ICM relay box	M51	Power tail gate glove switch	EM21	Connection with FRONT harness
M08-B	ICM relay box	M52	Power tail gate switch	EM31	Connection with FRONT harness
M09	Immobilizer module	M53	PTC heater	MC11	Connection with CONTROL harness
M10	Data link connector	M54	RF receiver	MC21	Connection with CONTROL harness
M11	Passenger temperature actuator	M55	Rheostat	MC31	Connection with CONTROL harness
M12	Driver temperature actuator	M56	Rear fog lamp switch	MC41	Connection with CONTROL harness
M13	Intake actuator	M58	Auto light sensor & Security indicator	MF11	Connection with FLOOR harness
M14	Mode actuator	M59	Photo sensor	MF21	Connection with FLOOR harness
M18	Audio	M60	Active incar sensor	MF31	Connection with FLOOR harness
M20	A/V head module (DVDC)	M61	Telescopic motor	MF41	Connection with FLOOR harness
M21	A/V head module (KEYBOARD)	M62	Tilt motor	MF51	Connection with FLOOR harness
M23-A	A/V head module (TUNER)	M63	Smart key door warning switch	MF61	Connection with FLOOR harness
M23-B	A/V head module (TUNER)	M64	Steering angle sensor	GM01	Ground
M24-A	A/V head module	M65	Tilt & Telescopic module	GM02	Ground
M24-B	A/V head module	M66	Tilt & Telescopic switch	GM03	Ground
M25	Front blower motor	M67	Tire pressure monitoring module	GM04	Ground
M26	Rear parking assist buzzer	M68	Water temperature sensor	GM05	Ground
M27	Center speaker	M70	TOD switch(W/O ESP)		
M28	Door warning switch	M75	Cigarette lighter & Power outlet		
M29	DVD control module	M80-A	Audio		
M30	Digital clock	M80-B	Audio		
M31	ESP switch	M80-C1	Audio	M71	Audio remocon switch
M32	Evaporator sensor	M80-C2	Audio	M74	Cruise remocon switch

#### REMOCON SWITCH HARNESS



Front Harness (1)

BATTERY

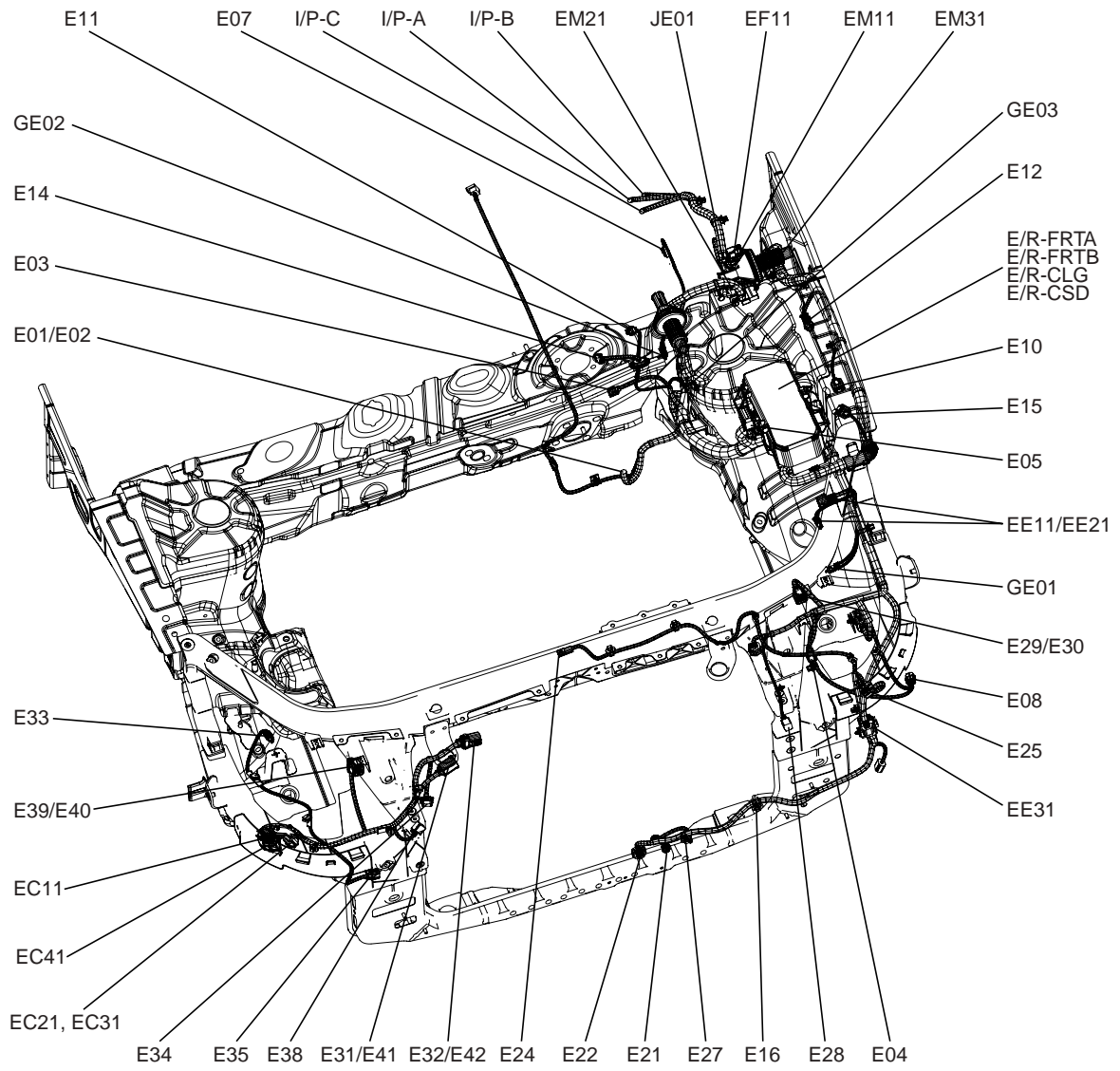
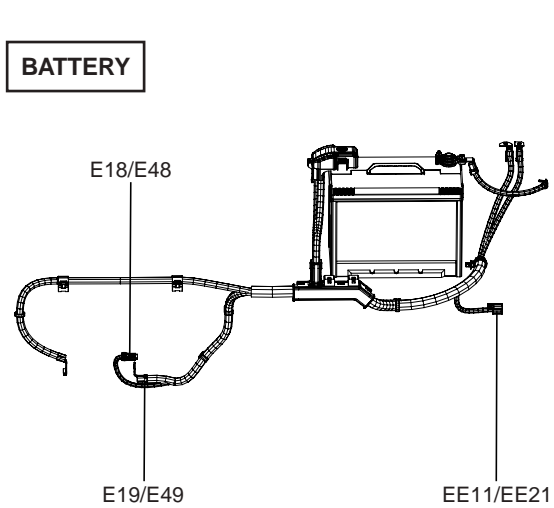

## FRONT HARNESS

### Front Harness (2)

HL-4

#### FRONT HARNESS

E01	ABS control module
E02	ESP control module
E03	Brake oil level sensor
E04	Burglra alarm horn
E05	Multipurpose check connector
E07	Foot brake switch
E08	Front fog lamp LH
E10	Front TPMS initiator LH
E11	Windshield defogger
E12	Front wheel sensor LH
E14	Front wiper motor
E15	External buzzer
E16	Semi active engine mounting solenoid
EE11	Connection with BATTERY harness(DSL)
EE21	Connection with BATTERY harness(GSL)
EE31	Connection with FRONT END EXT. LH harness
EF11	Connection with FLOOR harness
EM11	Connection with MAIN harness
EM21	Connection with MAIN harness
EM31	Connection with MAIN harness
E/R-FRTA	Connection with E/R JUNCTION BOX
E/R-FRTB	Connection with E/R JUNCTION BOX
I/P-A	Connection with I/P JUNCTION BOX
I/P-B	Connection with I/P JUNCTION BOX
I/P-C	Connection with I/P JUNCTION BOX
JE01	Joint connector
GE01	Ground
GE02	Ground
GE03	Ground

#### BATTERY HARNESS(DSL)

E18	Start solenoid
E19	Start motor
EE11	Connection with FRONT harness

#### BATTERY HARNESS(GSL)

E48	Start solenoid
E49	Start motor
EE21	Connection with FRONT harness

#### FRONT END EXT. LH HARNESS

E21	Ambient temperature sensor
E22	AQS sensor
E23	Head lamp leveling device actuator LH
E24	Hood switch
E25	Horn LH
E27	Ambient temperature clock sensor
E28	Front impact sensor LH
E29	Head lamp LH
E30	Head lamp LH
EE31	Connection with FRONT harness

#### FRONT END EXT. RH HARNESS

E31	Condenser fan motor(Except EURO)
E32	Radiator fan motor(Except EURO)
E33	Head lamp leveling device actuator RH
E34	Boost pressure sensor
E35	Horn RH
E38	Front impact sensor RH
E39	Head lamp RH
E40	Head lamp RH
E41	Condenser fan motor(EURO)
E42	Radiator fan motor(EURO)
EC11	Connection with CONTROL harness
EC21	Connection with CONTROL harness
EC31	Connection with CONTROL harness(DSL)
EC41	Connection with CONTROL harness(DSL)

Floor Harness (1)

HL-5

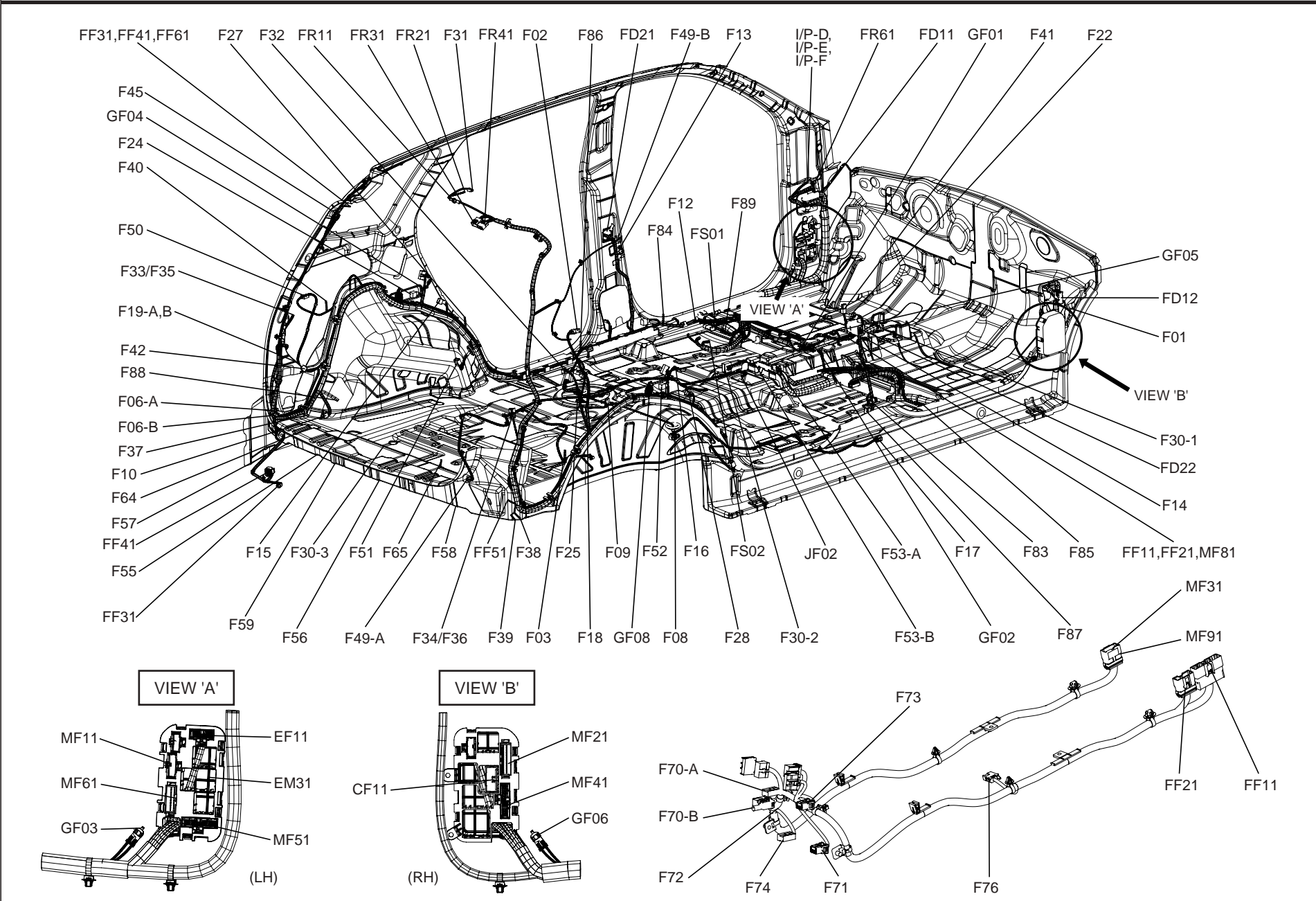



# CONTROL HARNESS

E65E4DB4

## Control Harness (1)

HL-7

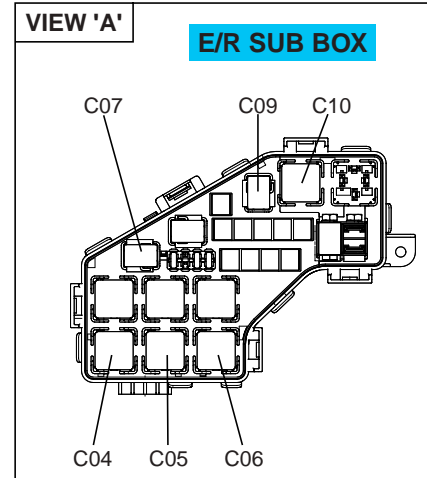
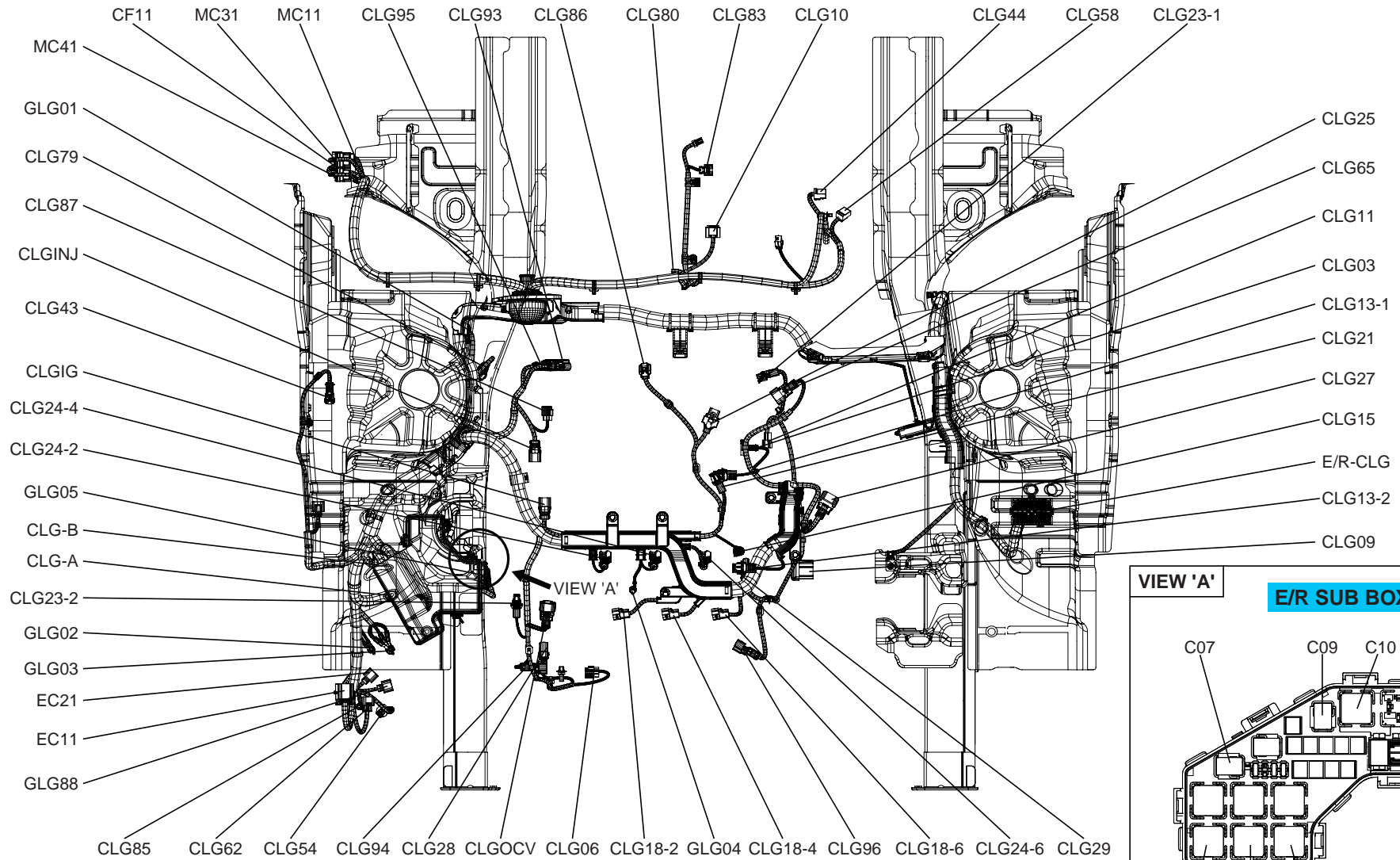



## CONTROL HARNESS

### Control Harness (2)

HL-8

#### CONTROL HARNESS(LAMBDA 3.8L)

C04	Radiator fan relay	CLG62	Washer fluid level sensor
C05	Condenser fan relay #1	CLG65	ETC motor & Throttle position sensor
C06	Rear A/Con relay	CLG79	A/Con pressure transducer
C07	Power outlet relay	CLG80	Semi active engine mounting control module
C09	Head lamp(Low) relay RH	CLG83	G-sensor
C10	Condenser fan relay #2	CLG85	Front fog lamp RH
CLG03	Oil temperature sensor	CLG86	Power steering pressure sensor
CLG06	Generator	CLG87	Variable intake manifold valve
CLG09	TCM	CLG88	Head lamp washer motor
CLG10	Yaw rate sensor	CLG93	Oxygen sensor #1 (B1/S1)
CLG11	Engine coolant temperature sensor	CLG94	Oxygen sensor #2 (B2/S1)
CLG13-1	Camshaft position sensor #1	CLG95	Oxygen sensor #3 (B1/S2)
CLG13-2	Camshaft position sensor #2	CLG96	Oxygen sensor #4 (B2/S2)
CLG15	Oil pressure switch	CLG-A	ECM
CLG18-2	Ignition coil #2	CLG-B	ECM
CLG18-4	Ignition coil #4	CF11	Connection with FLOOR harness
CLG18-6	Ignition coil #6	CLGIG	Connection with IGNITION COIL harness
CLG21	Purge control solenoid valve	CLGINJ	Connection with INJECTOR harness
CLG23-1	Knock sensor #1	CLGOCV	Connection with OIL CONTROL VALVE harness
CLG23-2	Knock sensor #2	EC11	Connection with FRONT END EXT. harness
CLG24-2	Injector #2	EC21	Connection with FRONT END EXT. harness
CLG24-4	Injector #4	E/R-CLG	Connection with E/R JUNCTION BOX
CLG24-6	Injector #6	MC11	Connection with MAIN harness
CLG25	Manifold absolute pressure sensor	MC31	Connection with MAIN harness
CLG27	Mass air flow sensor	MC41	Connection with MAIN harness
CLG28	A/Con compressor	GLG01	Ground
CLG29	Crankshaft position sensor	GLG02	Ground
CLG43	Front wheel sensor RH	GLG03	Ground
CLG44	Accelerator pedal position sensor	GLG04	Ground
CLG54	Washer motor	GLG05	Ground
CLG58	Stop lamp switch		

#### INJECTOR HARNESS

CLG24-1	Injector #1
CLG24-3	Injector #3
CLG24-5	Injector #5
CLGINJ	Connection with CONTROL harness

#### IGNITION COIL HARNESS

CLG18-1	Ignition coil #1
CLG18-3	Ignition coil #3
CLG18-5	Ignition coil #5
CLGIG	Connection with CONTROL harness

#### OIL CONTROL VALVE HARNESS

CLG98-1	Oil control valve #1
CLG98-2	Oil control valve #2
CLGOCV	Connection with CONTROL harness

# CONTROL HARNESS

## Control Harness (3)

HL-9

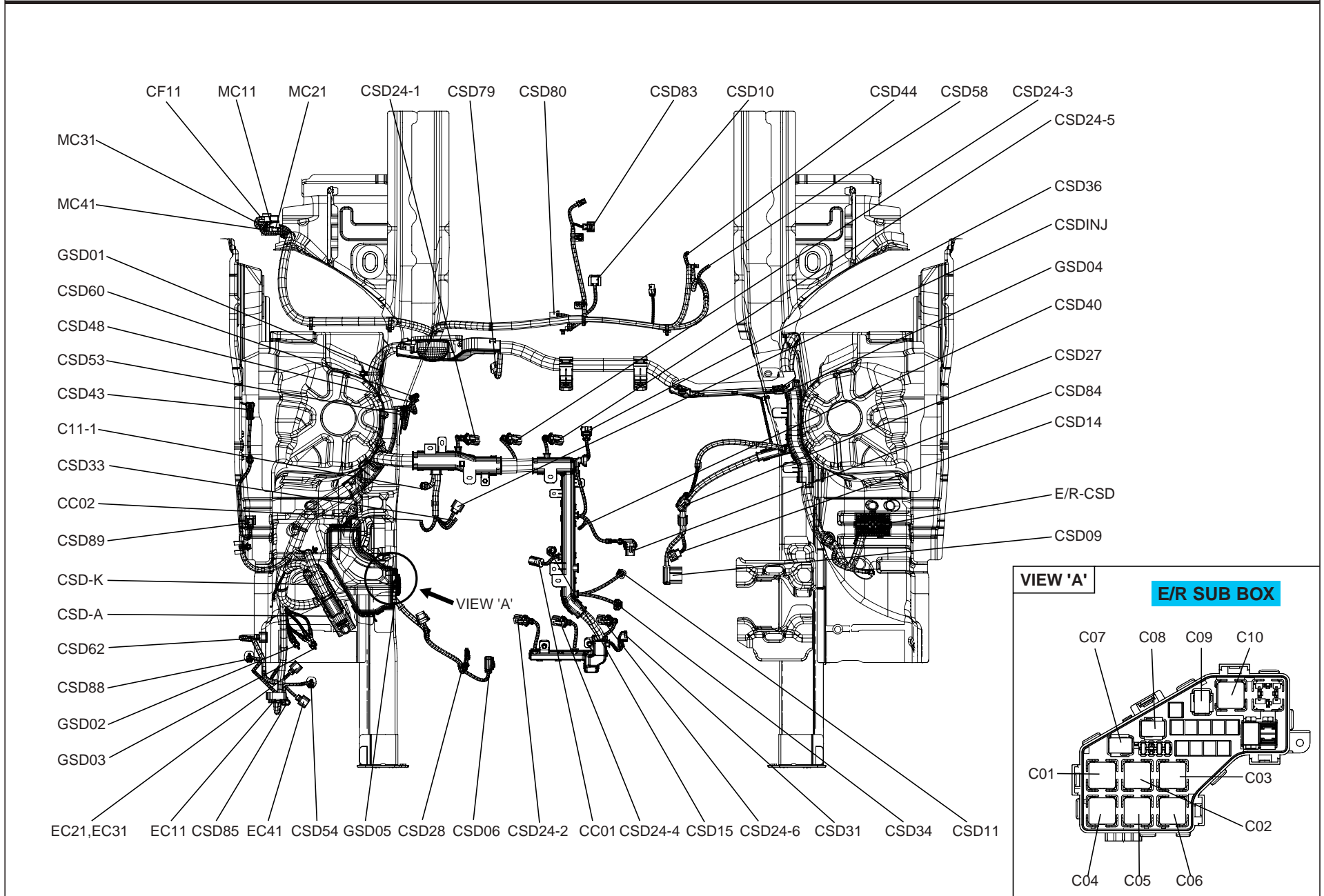

## CONTROL HARNESS

### Control Harness (4)

HL-10

#### CONTROL HARNESS(S-ENG 3.0L)

C01	PTC heater relay #1	CSD60	Thermo switch
C02	PTC heater relay #2	CSD62	Washer fluid level sensor
C03	PTC heater relay #3	CSD79	A/Con pressure transducer
C04	Radiator fan relay	CSD80	Semi active engine mounting control module
C05	Condenser fan relay #1	CSD83	G-sensor
C06	Rear A/Con relay	CSD84	Electrical VGT actuator
C07	Power outlet relay	CSD85	Front fog lamp RH
C08	Fuel filter heater relay	CSD88	Head lamp washer motor
C09	Head lamp(Low) relay RH	CSD89	Front TPMS Initiator RH
C10	Condenser fan relay #2	CSD-A	ECM
C11-1	Glow control module	CSD-K	ECM
CSD06	Generator	CC01	Connection with MPROP EXT.harness
CSD09	TCM	CC02	Connection with GLOW PLUG harness
CSD10	Yaw rate sensor	CF11	Connection with FLOOR harness
CSD11	Engine coolant temperature sensor	CSDINJ	Connection with INJECTOR harness
CSD14	Crankshaft position sensor	EC11	Connection with FRONT END EXT. RH harness
CSD15	Oil pressure switch	EC21	Connection with FRONT END EXT. RH harness
CSD24-2	Injector #2	EC31	Connection with FRONT END EXT. RH harness
CSD24-4	Injector #4	EC41	Connection with FRONT END EXT. RH harness
CSD24-6	Injector #6	E/R-CSD	Connection with E/R JUNCTION BOX
CSD27	Air flow sensor	MC11	Connection with MAIN harness
CSD28	A/Con compressor	MC21	Connection with MAIN harness
CSD31	EGR actuator	MC31	Connection with MAIN harness
CSD33	Rail pressure sensor	MC41	Connection with MAIN harness
CSD34	Rail pressure control valve	GSD01	Ground
CSD36	Lambda sensor	GSD02	Ground
CSD40	Variable swirl control actuator	GSD03	Ground
CSD43	Front wheel sensor RH	GSD04	Ground
CSD44	Accelerator pedal position sensor	GSD05	Ground
CSD48	Fuel filter heater		
CSD53	Fuel filter warning sensor		
CSD54	Washer motor		
CSD58	Stop lamp switch		

#### MPROP HARNESS

CSD32	Fuel temperature sensor
CSD38	Fuel metering unit
CC01	Connection with CONTROL harness

#### GLOW PLUG HARNESS

C11-2	Glow control module
C12-1	Glow plug #1
C12-2	Glow plug #2
C12-3	Glow plug #3
C12-4	Glow plug #4
C12-5	Glow plug #5
C12-6	Glow plug #6
CC02	Connection with CONTROL harness

#### INJECTOR HARNESS

CSD24-1	Injector #1
CSD24-3	Injector #3
CSD24-5	Injector #5
CSD92	Camshaft position sensor
CSDINJ	Connection with CONTROL harness



Door Harness (1)

HL-11

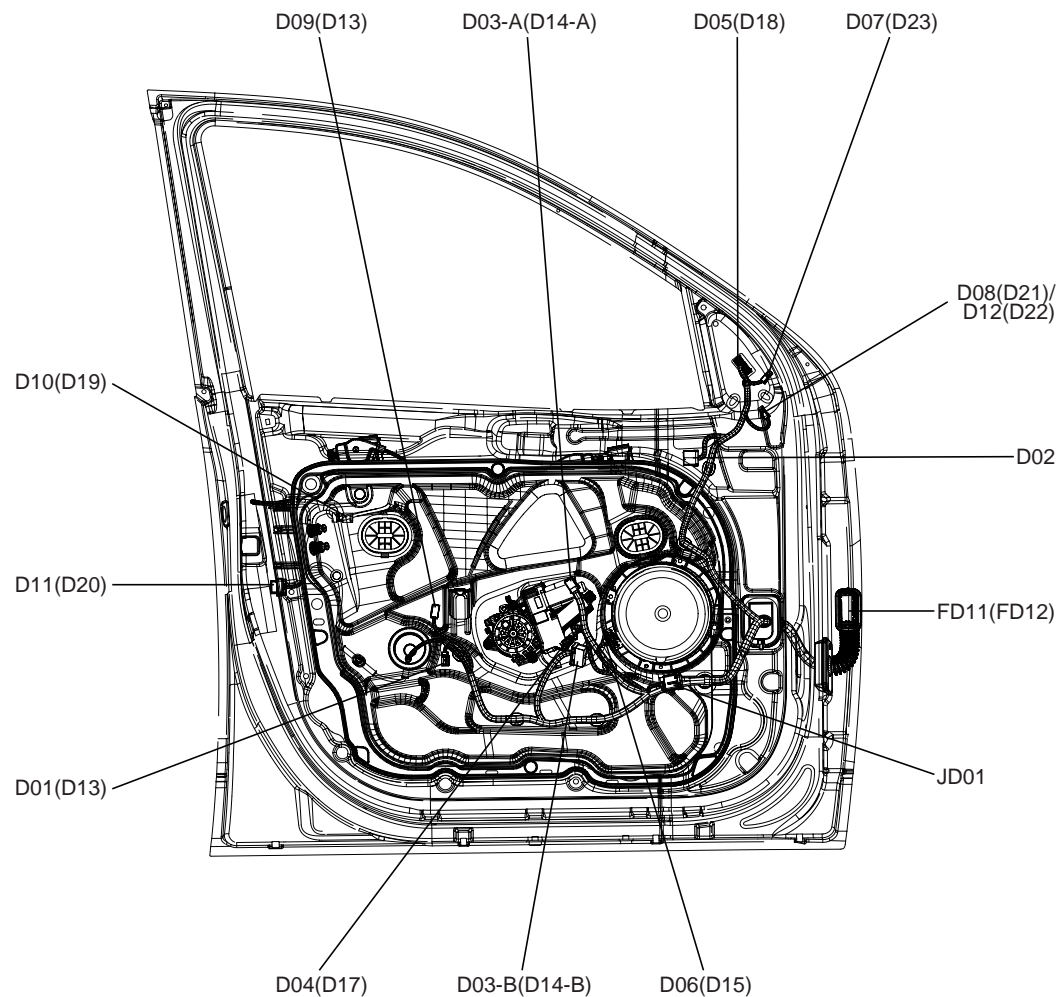

( ) : RIGHT

**DRIVER DOOR HARNESS**

- D01 Driver door lamp
- D02 IMS switch
- D03-A Power window main switch
- D03-B Power window main switch
- D04 Driver safety window ECM
- D05 Power outside mirror motor & Defogger LH
- D06 Front door speaker LH
- D07 Front tweeter speaker LH (Surround)
- D08 Front tweeter speaker LH(W/O AMP)
- D09 Fuel lid switch
- D10 Front smart key outside handle LH
- D11 Front door lock actuator LH
- D12 Front tweeter speaker LH (Non Surround)
- FD11 Connection with FLOOR harness
- JD01 Joint connector

**PASSENGER DOOR HARNESS**

- D13 Passenger door lamp
- D14-A Front power window switch RH
- D14-B Front power window switch RH
- D15 Front door speaker RH
- D17 Front power window motor RH
- D18 Power outside mirror motor & Defogger RH
- D19 Front smart key outside handle RH
- D20 Front door lock actuator RH
- D21 Front tweeter speaker RH(W/O AMP)
- D22 Front tweeter speaker RH (Non Surround)
- D28 Front tweeter speaker RH (Surround)
- FD12 Connection with FLOOR harness

# DOOR HARNESS

## Door Harness (2)

HL-12

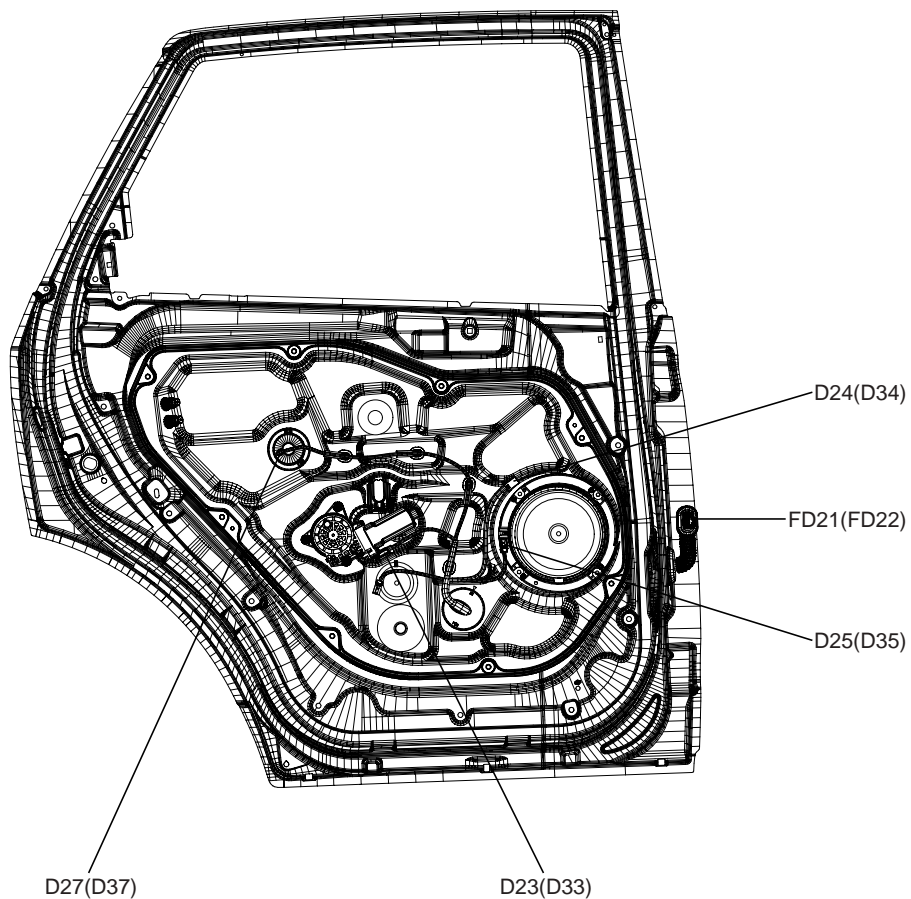

### REAR DOOR HARNESS LH

- D23 Rear power window motor LH
- D24 Rear power window switch LH
- D25 Rear door speaker LH
- D27 Rear door lock actuator LH
- FD21 Connection with FLOOR harness

### REAR DOOR HARNESS RH

- D33 Rear power window motor RH
- D34 Rear power window switch RH
- D35 Rear door speaker RH
- D37 Rear door lock actuator RH
- FD22 Connection with FLOOR harness

( ) : RIGHT

Tail Gate Harness (1)

HL-13

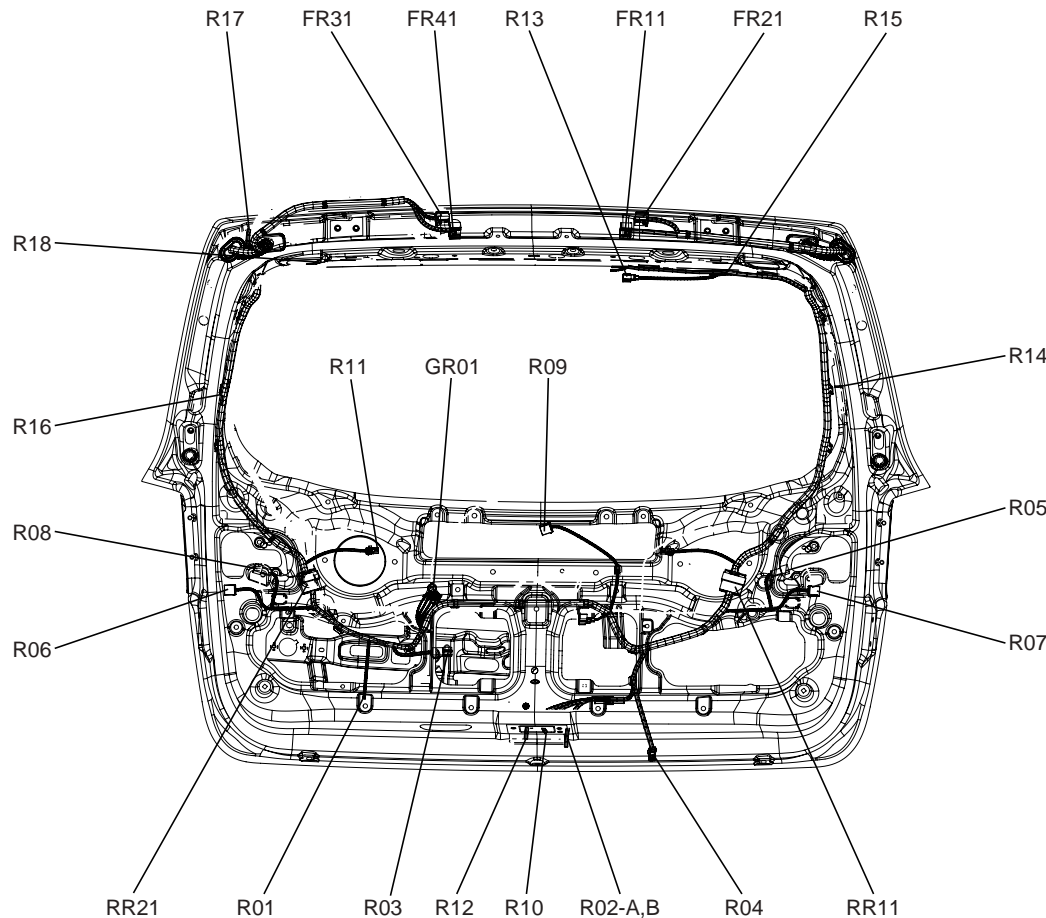

**TAIL GATE HARNESS**

- R01 Power tail gate buzzer
- R02-A Power latch #1
- R02-B Power latch #2
- R03 Tail gate handle switch & License lamp
- R04 Power tail gate ON/OFF switch
- R05 Rear combination lamp LH(IN)
- R06 Rear combination lamp RH(IN)
- R07 Rear combination lamp LH(IN)(With LED)
- R08 Rear combination lamp RH(IN)(With LED)
- R09 Rear wiper motor
- R10 Tail gate lock actuator
- R11 Tail gate lock lamp
- R12 Rear camera
- RR11 Connection with TAIL GATE EXT. LH harness
- RR21 Connection with TAIL GATE EXT. RH harness
- GR01 Ground

**TAIL GATE EXT. LH HARNESS**

- R13 High-mounted stop lamp(Spoiler)
- R14 Rear window defogger
- R15 Pinch switch LH
- FR11 Connection with FLOOR harness
- FR21 Connection with FLOOR harness
- RR11 Connection with TAIL GATE harness

**TAIL GATE EXT. RH HARNESS**

- R16 Rear window defogger
- R17 Tail gate speaker RH
- R18 Pinch switch RH
- FR31 Connection with FLOOR harness
- FR41 Connection with FLOOR harness
- RR21 Connection with TAIL GATE harness

Roof Harness (1)

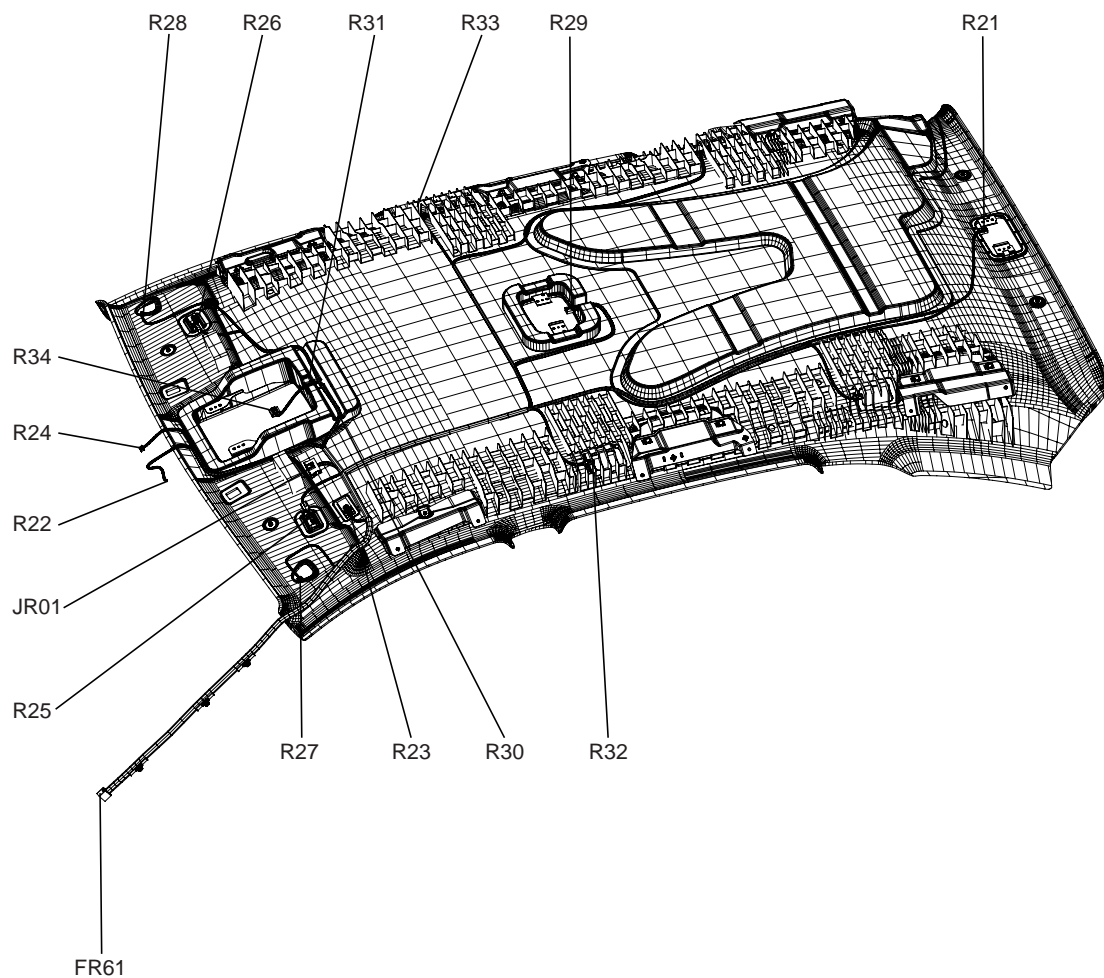

ROOF HARNESS

- R21 Cargo lamp
- R22 Electro chromic mirror
- R23 Roof MIC
- R24 Rain sensor
- R25 Driver vanity lamp
- R26 Passenger vanity lamp
- R27 Driver vanity lamp switch
- R28 Passenger vanity lamp switch
- R29 Room lamp
- R30 Sunroof switch
- R31 Sunroof control module
- R32 Rear Map Lamp LH
- R33 Rear Map Lamp RH
- R34 Overhead console lamp
- FR61 Connection with FLOOR harness
- JR01 Joint connector

**Air Bag Harness (1)**

**HL-15**

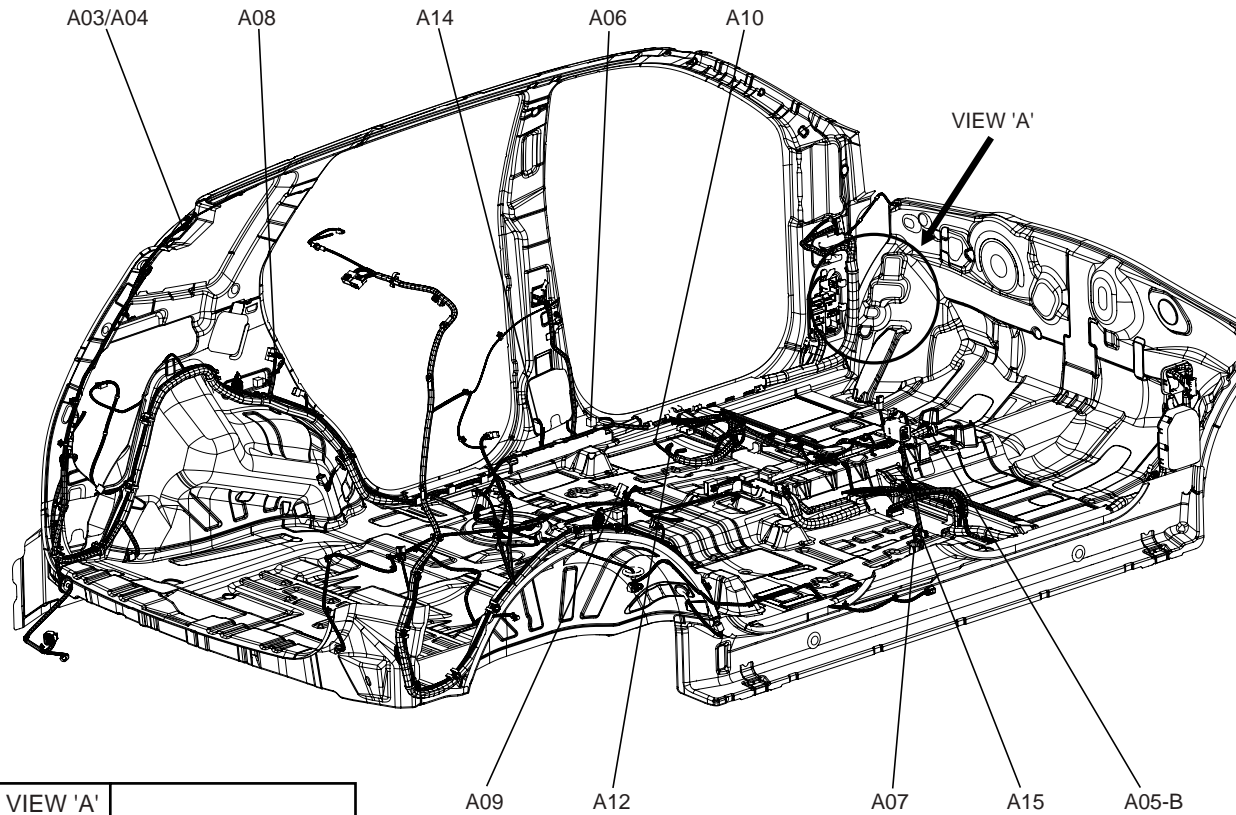

**AIR BAG HARNESS**

- A03 Driver curtain air bag
- A04 Passenger curtain air bag
- A05-B SRS control module
- A06 Front side impact sensor LH
- A07 Front side impact sensor RH
- A08 Rear side impact sensor LH
- A09 Rear side impact sensor RH
- A10 Driver side air bag
- A12 Passenger side air bag
- A14 Driver seat belt pretensioner
- A15 Passenger seat belt pretensioner

**AIR BAG EXT. HARNESS**

- A05-A SRS control module
- A17 Telltale lamp
- A18 Driver air bag
- A19 Passenger air bag
- A20 Passenger air bag ON/OFF switch
- I/P-M Connection with I/P JUNCTION BOX
- GA02 Ground

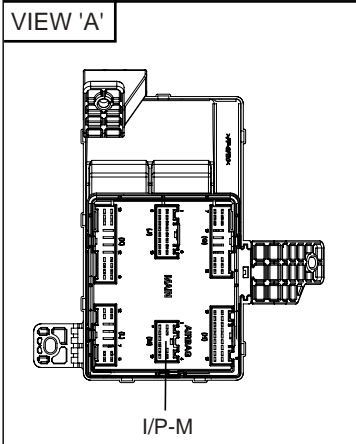



**Seat Harness (1)**

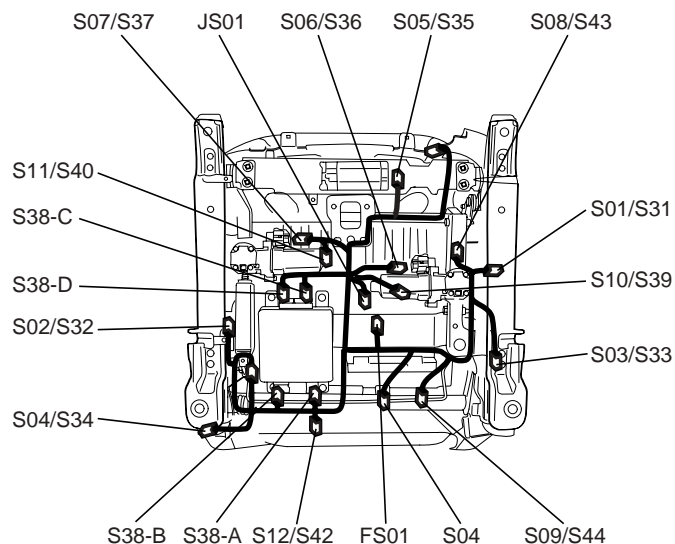

**DRIVER SEAT HARNESS(W/O IMS)**

- S01 Driver seat manual switch
- S02 Driver slide limit switch
- S03 Driver reclining limit switch
- S04 Driver reclining motor
- S05 Driver slide motor
- S06 Front height adjuster motor
- S07 Rear height adjuster motor
- S08 Driver lumbar support switch
- S09 Driver lumbar support motor
- S10 Front height limit switch
- S11 Rear height limit switch
- S12 Driver seat warmer
- FS01 Connection with FLOOR harness

**DRIVER SEAT HARNESS(WITH IMS)**

- S31 Driver seat manual switch
- S32 Driver slide limit switch
- S33 Driver reclining limit switch
- S34 Driver reclining motor
- S35 Driver slide motor
- S36 Front height adjuster motor
- S37 Rear height adjuster motor
- S38-A IMS control module
- S38-B IMS control module
- S38-C IMS control module
- S38-D IMS control module
- S39 Front height limit switch
- S40 Rear height limit switch
- S42 Driver seat warmer
- S43 Driver lumbar support switch
- S44 Driver lumbar support motor
- FS01 Connection with FLOOR harness
- JS01 Joint connector

**PASSENGER SEAT HARNESS**

- S21 Passenger seat manual switch
- S22 Passenger slide limit switch
- S23 Passenger reclining limit switch
- S24 Passenger reclining motor
- S25 Passenger slide motor
- S26 Passenger seat warmer
- FS02 Connection with FLOOR harness

